



INTERNATIONAL APPLICATION PUBLISHED UNDER THE PATENT COOPERATION TREATY (PCT)

<p>(51) International Patent Classification ⁷ : A63B 24/00, A61B 5/00, G06F 19/00</p>	<p>A1</p>	<p>(11) International Publication Number: WO 00/62867 (43) International Publication Date: 26 October 2000 (26.10.00)</p>
<p>(21) International Application Number: PCT/IB00/00460 (22) International Filing Date: 13 April 2000 (13.04.00) (30) Priority Data: BO99A000179 16 April 1999 (16.04.99) IT (71) Applicant: TECHNOGYM S.R.L. [IT/IT]; Via G. Perticari, 20, I-47035 Gambettola (IT). (72) Inventor: ALESSANDRI, Nerio; Via Matteotti, 27, I-47020 Longiano (IT). (74) Agent: LANZONI, Luciano; Bugnion S.p.A., Via Goito, 18, I-40126 Bologna (IT).</p>	<p>(81) Designated States: AE, AL, AM, AT, AU, AZ, BA, BB, BG, BR, BY, CA, CH, CN, CU, CZ, DE, DK, EE, ES, FI, GB, GD, GE, GH, GM, HR, HU, ID, IL, IN, IS, JP, KE, KG, KP, KR, KZ, LC, LK, LR, LS, LT, LU, LV, MD, MG, MK, MN, MW, MX, NO, NZ, PL, PT, RO, RU, SD, SE, SG, SI, SK, SL, TJ, TM, TR, TT, UA, UG, UZ, VN, YU, ZA, ZW, ARIPO patent (GH, GM, KE, LS, MW, SD, SL, SZ, TZ, UG, ZW), Eurasian patent (AM, AZ, BY, KG, KZ, MD, RU, TJ, TM), European patent (AT, BE, CH, CY, DE, DK, ES, FI, FR, GB, GR, IE, IT, LU, MC, NL, PT, SE), OAPI patent (BF, BJ, CF, CG, CI, CM, GA, GN, GW, ML, MR, NE, SN, TD, TG).</p> <p>Published <i>With international search report.</i></p>	

(54) Title: A TELECOMMUNICATION SYSTEM FOR EXCHANGING PHYSIOLOGICAL STATE INFORMATION BETWEEN A PHYSICAL PERSON AND AN INFORMATION SYSTEM

(57) Abstract

A telecommunication system for exchanging information concerning personalised parameters of physiological state between a physical person and an information system (2) comprises measuring means (3) for measuring physiological parameters of the physical person; and processing means (4) interconnected with the measuring means (3) and with the information system (2), for transmitting to the information system (2) at least input signals (a1) corresponding to the physiological parameters acquired by the person and for transmitting to the physical person output information (b; c) corresponding to those received in return from the information system (2). The telecommunication system (1) allows a dialogue between the physical person and the information system (2) to control his/her own physical condition in a scientifically accurate and personalised manner.

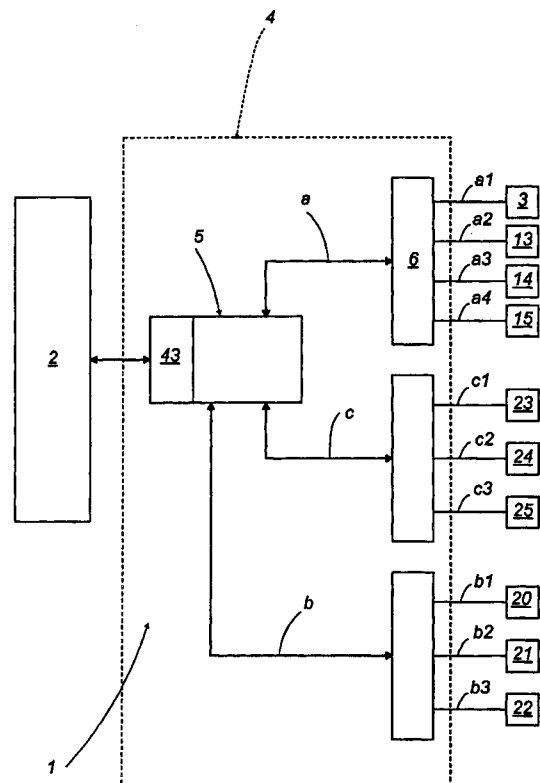

FOR THE PURPOSES OF INFORMATION ONLY

Codes used to identify States party to the PCT on the front pages of pamphlets publishing international applications under the PCT.

AL	Albania	ES	Spain	LS	Lesotho	SI	Slovenia
AM	Armenia	FI	Finland	LT	Lithuania	SK	Slovakia
AT	Austria	FR	France	LU	Luxembourg	SN	Senegal
AU	Australia	GA	Gabon	LV	Latvia	SZ	Swaziland
AZ	Azerbaijan	GB	United Kingdom	MC	Monaco	TD	Chad
BA	Bosnia and Herzegovina	GE	Georgia	MD	Republic of Moldova	TG	Togo
BB	Barbados	GH	Ghana	MG	Madagascar	TJ	Tajikistan
BE	Belgium	GN	Guinea	MK	The former Yugoslav Republic of Macedonia	TM	Turkmenistan
BF	Burkina Faso	GR	Greece			TR	Turkey
BG	Bulgaria	HU	Hungary	ML	Mali	TT	Trinidad and Tobago
BJ	Benin	IE	Ireland	MN	Mongolia	UA	Ukraine
BR	Brazil	IL	Israel	MR	Mauritania	UG	Uganda
BY	Belarus	IS	Iceland	MW	Malawi	US	United States of America
CA	Canada	IT	Italy	MX	Mexico	UZ	Uzbekistan
CF	Central African Republic	JP	Japan	NE	Niger	VN	Viet Nam
CG	Congo	KE	Kenya	NL	Netherlands	YU	Yugoslavia
CH	Switzerland	KG	Kyrgyzstan	NO	Norway	ZW	Zimbabwe
CI	Côte d'Ivoire	KP	Democratic People's Republic of Korea	NZ	New Zealand		
CM	Cameroon			PL	Poland		
CN	China	KR	Republic of Korea	PT	Portugal		
CU	Cuba	KZ	Kazakstan	RO	Romania		
CZ	Czech Republic	LC	Saint Lucia	RU	Russian Federation		
DE	Germany	LI	Liechtenstein	SD	Sudan		
DK	Denmark	LK	Sri Lanka	SE	Sweden		
EE	Estonia	LR	Liberia	SG	Singapore		

Description

A Telecommunication System for Exchanging Physiological State Information between a Physical Person and an Information System.

Technical Field

The present invention relates to the technical field of information systems in general which allow an exchange of information between a user and a data base or a network; in particular this system can be correlated to the fitness or wellness sector and integrated with exercise machines for training, re-educating and maintaining the well-being of the body.

Background Art

Exercise machines of more modern and advanced conception, both professional and amateur-oriented, are designed in such a way as to allow the user to plan his/her physical activities in relation with his/her own personal characteristics and requirements.

For this purpose machines are known which, although conceived for a general employment able to meet the diversified demands of a plurality of users, can then be pre-set on each occasion as a function of each individual user and of the workout plan the user actually intends to follow. A personalised management system for this type of machined is, for instance, already known from the patent IT-1.274.053 in the name of the same Applicant.

Disclosure of Invention

The present invention more particularly relates to a telecommunication system which extends beyond the physical borders of a gym or of a physical education venue in general, and has the fundamental aim of allowing a further advancement of the individual management of physical activities and a more advanced and accurate

personalisation so as to take into consideration the person's actual physiological conditions, enabling to take into account also a series of other parameters such as those concerning his/her nutrition and those concerning the energy consumption linked with that person's actual daily lifestyle.

5 According to the invention this aim is achieved by a telecommunication system for exchanging information concerning physiological state parameters between a physical person and an information system, characterised in that it comprises measuring means for measuring physiological parameters directly from the physical person; and processing means interconnected with the measuring means and with the
10 information system to transmit to the information system at least input signals corresponding to the acquired physical parameters and to transmit to the physical person output information corresponding with those received in return from the information system.

 The invention allows the quantification and the scientifically planned graduation
15 of the workload as a function of the measurement and processing of a set of physiological parameters which are significant for representing the physical condition of the user and whose control allows in the first place to monitor the reaching of reference or target thresholds of each individual users.

 If the system comprises a terminal that allows the user to interface with the
20 processing means, to enter personal and specific data therein, the user's activity can also be planned as a function of other information wherefrom it is possible, for instance, to deduce: the energetic content stored with daily nutrition or referable to a different time interval; and/or the portion of energy content dissipated through the user's work activity. All this to allow to manage the user's physical activity on the
25 exercise machine in a personalised, rational manner as a function of a realistic energy budget. Similarly with regard to the management of diets, nutrition, linked to the aforesaid physical activities or otherwise.

 The terminal can allow the user to connect also to the information system both locally and remotely. It can be connected to the information system by means of a

fixed physical network; or, if the terminal comprises for instance a radiotelephone, it can allow the wireless exchange of information between the user and the information system. In either case the exchange of information is easy, immediate and possible on a global and planetary scale.

5 Providing the terminal with appropriate interface means, such as a board with miniaturised circuitry, in addition to the acquisition of information from the information system it is also possible to store signals which can allow to query the data base or the network or to configure in a personalised and automated manner the exercise machines of the gym normally attended by the user or any other gym he/she
10 may desire to access, for instance when staying in a location more or less distant from his/her habitual residence.

Naturally, the aforesaid personalisation of the configuration of the machines is not limited to exercise machines, but can be extended also to electrical appliances or to machines finding more general employment whose functionalities allow, for
15 instance, to interact in the broadest sense of the term with the physical well-being of the user and/or with his/her energy exchanges with the surrounding environment.

If the system according to the invention is provided with suitable communication software constituted for instance by a standard operating system such as Windows CE, the telecommunication system according to the invention can advantageously
20 interconnect with local area networks such as intranets or with the global network, the Internet, and dialogue with data bases, with processing centres or intelligent software systems able to manage incoming and output information about person's physical condition, physical activities and/or medical and scientific information connectable thereto.

25 To assure on the one hand the confidentiality of the data and on the other the security of a specific personalisation, the system can advantageously be equipped also with means for recognising the person embodied for instance by means of a fingerprint reader or a retinal image reader.

Description of the Drawings

The technical features of the invention, according to the aforesaid aims, can clearly be noted from the content of the claims set out below and its advantages shall become more readily apparent in the detailed description that follows, made with
5 reference to the accompanying drawings, which represent an embodiment provided purely by way of non-limiting example, in which:

- Figure 1 is a schematic block function representation of the telecommunication system according to the invention; and
- Figure 2 is a detailed block function representation of a variation in the
10 execution of the system of Figure 1.

Description of the Illustrative Embodiment

With reference to the accompanying drawings, the number 1 indicates in its entirety a telecommunication system for exchanging information concerning personal
15 physiological state parameters between a physical person and an information system 2.

The system 1 essentially comprises measuring means 3, such as a cardiac frequency meter, for measuring directly from the physical person physiological parameters significant for monitoring his/her physical condition; and processing means
20 4 which include a software for processing and handling information pertaining to physiological condition parameters of the person and which are interconnected with the measuring means and with the information system 2, to transmit to the information system 2 this information in the form of input signals a1 and to transmit to the physical person output information b, c corresponding with that received in return from the
25 information system 2.

The processing means 4 [Figure 1] comprise a microprocessor device 5, a terminal 6 and first interface means 7, 8, 9, 10. The microprocessor device 5 is provided with a central processing unit CPU; with means 40, 41, 42 for storing data, programs and information for external peripheral units, and with a signal modulation

and demodulation unit - modem 43.

The terminal 6 is preferably of the portable, palmtop type and it is integrated in a single body with the microprocessor device 5. Moreover, according to an alternative embodiment, shown in Figure 2, it comprises a radiotelephone which allows the person to be connected with the information system 2 according to a wireless mode.

The interface means 7, 8, 9, 10 are interconnected with the measuring means 3 and can be interconnected with an input device 13 and with means 15, 16 for identifying the person. The input device 13 can be embodied by a keyboard or by a barcode reader. The means 15, 16 for identifying the person can be embodied by a fingerprint reader and/or also by a retinal image reader.

The first interface means 7, 8, 9, 10 in combination with the microprocessor device 5 allow to enter into the information system 2, and through the first interface means 7, 8, 9, 10 and the microprocessor device 5, information that is understandable for the operating system suitably converting the signals 1a of the measuring means 3 and of the information a2, a3, a4 entered by the person by means of the input device 13 and/or through identification means 15, 16.

Clearly, the information that can be entered into the information system 2 can be the most disparate, as it is easy to understand that through the keyboard the physical person can enter the most widely varied information establishing, through the software that equips the processing means 4, a veritable dialogue with the information system 2. The insertion of information through the bar code reader can allow to send to the information system 2, in a rapid and complete manner, information for instance on the nature, quality and quantity of food products consumed by the user with his/her daily nutrition; information which can then be processed by the information system 2 for a whole series of diet and energy information which can be both aimed at informing the physical person or at being exploited to quantify and modulate the workload needed by the physical person to work them off.

For the communication to the physical person of the data b1, b2, b3 processed by the information system 2, the processing means 4 can be provided with an output

device 20, 21, 22 interconnected with related second interface means 29, 30, 31. The output device can present the most disparate embodiments and can be embodied for instance by a video 20, by a display 21, by a printer 22 and can lastly be integrated in the same processing means 4 and, more in particular in the portable terminal 6 or even
5 in the radiotelephone itself which an integrate in a single body also the second interface means 29, 30, 31 themselves.

The processing means 4 also comprise third interface means 35, 36, 37 connected with an output device 23, 24 which receives from the information system 2 information in the form of appropriately processed signals c1, c2, c3. The third
10 interface means 35, 36, 37 can be integrated in the same portable terminal 6 or even in the radiotelephone. The output device connected thereto can assume a broad range of concrete embodiments, represented by way of non limiting example by a board 23 with miniaturised circuitry able to store said signals c1, c2, c3; or by a directly connected machine 24, 25 whose functionalities can be modulated according to the
15 person's physiological parameters.

The board 23 can be of the kind employed by the system for managing the personalisation of exercise machines already subjected to patent protection by the same Applicant, and can allow the physical person to store through the communication system 1 the signals which will be necessary for configuring the exercise machines
20 when the physical person accesses his/her own gym.

Naturally, through portable processing means 4 it is possible to connect to the operating system 2 the exercise machine 24 of one's own gym or in general any other electrical appliance 25 able to interact energetically with the person and to download in real time from the operating system 2 the configuration parameters necessary for
25 personalising the machine 24, 25.

As to the information system 2, from the above description one can observe that it can include a computerised data base and/or even the software for processing the physical person's own personal data as well as data contained in the data base. Moreover, the information system 2 can reside within a local computer or otherwise

can be contained in a remote server reachable by the processing means 4 through a telecommunication and information network 28 which can be local, remote, fixed or wireless like those currently employed for mobile telephony. Interactivity with the network 28 shall be enabled by providing the processing means 4 with suitable software, for instance of the Windows CE type, which is found to be particularly well suited to equip portable, palmtop processing means 4.

The invention thus conceived can be subject to numerous modifications and variations, without thereby departing from the scope of the inventive concept. Moreover, all components can be replaced by technically equivalent elements.

Claims

1. A telecommunication system for exchanging information concerning personalised physiological state parameters between a physical persona and an information system (2), characterised in that it comprises means (3) for measuring physiological parameters from the physical person; and processing means (4) interconnected with the measuring means (3) and with the information system (2), for transmitting to the information system (2) at least input signals (a1) corresponding to the physiological parameters acquired from the person and transmitting to the physical person output information (b; c) corresponding to those received in return from the information system (2).

2. A system as claimed in claim 1, characterised in that the measuring means (3) comprise a cardiac frequency meter for monitoring the person's physical condition.

3. A system as claimed in claim 1, characterised in that the processing means (4) comprise a microprocessor device (5), a terminal (6) and at least first interface means (7, 8, 9, 10), which are interconnected to each other and with the measuring means (3) to send to the information system (2) at least information in the form of input signals (a1) coming from the user.

4. A system as claimed in claim 3, characterised in that the terminal (6) is portable, of the palmtop type.

5. A system as claimed in claim 4, characterised in that the terminal (6) and the microprocessor device (5) are integrated in a single body.

6. A system as claimed in claims 3, 4 or 5, characterised in that the terminal (6) includes a radiotelephone.

7. A system as claimed in claim 3, characterised in that it comprises a data input device (13) connected to the interface means (7, 8, 9, 10), through which the person sends information in the form of data (a2) to the processing means (4).

5 8. A system as claimed in claim 7, characterised in that the data input device (13) includes a keyboard.

9. A system as claimed in claim 7, characterised in that the input device (13) includes a barcode reader.

10

10. A system as claimed in claim 1, characterised in that it comprises means (14, 15) for personally identifying the person.

15

11. A system as claimed in claim 10, characterised in that the personal identification means include a reader (14) of the person's fingerprint.

12. A system as claimed in claim 10, characterised in that the personal identification means include a reader (15) of the person's retinal image.

20

13. A system as claimed in one of the claims from 10 to 12, characterised in that the interface means (7, 8, 9, 10) are functionally interconnected with the personal identification means (14, 15) to send to the information system (2) corresponding input information (a3, a4) coming from the person.

25

14. A system as claimed in claim 1, characterised in that the processing means (4) comprise second interface means (29, 30, 31) for at least a data output device (20, 21, 22) provided to transmit to the person information in the form of data (b1, b2, b3) coming from the information system (2).

15. A system as claimed in claim 14, characterised in that the output device is a video (20).

5 16. A system as claimed in claim 14, characterised in that the output device is a display (21).

17. A system as claimed in claim 14, characterised in that the output device is a printer (22).

10 18. A system as claimed in claims 14 through 17, characterised in that the output device (20) is integrated with the processing means (4).

15 19. A system as claimed in claim 14, characterised in that the processing means (4) include a terminal (6) incorporating at least the second interfacing means (29, 30, 31) for the data output device (20).

20. A system as claimed in claim 17, characterised in that the terminal (6) is portable.

20 21. A system as claimed in claim 19, characterised in that the terminal (6) includes a radiotelephone.

25 22. A system as claimed in claim 1, characterised in that the processing means (4) comprise at least third interface means (35, 36, 37) for a device (23, 24) for outputting information in the form of signals (c1, c2, c3) processed by the processing means (4) based on information (c) coming from the information system (2).

23. A system as claimed in claim 22, characterised in that the processing means (4) comprise a terminal (6) provided with said third interface means (35, 36, 37).

24. A system as claimed in claim 23, characterised in that the terminal (6) is portable.

5 25. A system as claimed in claim 24, characterised in that the terminal (6) includes a radiotelephone.

26. A system as claimed in claim 22, characterised in that the output device comprises a board (23) with miniaturised circuitry able at least to store said signals (c1, c2, c3).

10 27. A system as claimed in claim 22, characterised in that the output device is a machine (24, 25) having functionalities which can be modulated as a function of the person's physiological parameters.

15 28. A system as claimed in claim 27, characterised in that said machine is an exercise machine (24).

29. A system as claimed in claim 27, characterised in that the machine is an electrical appliance (25) interacting with the physical person.

20 30. A system as claimed in any of the previous claims, characterised in that the information system (2) includes a computerised data base.

25 31. A system as claimed in claim 30, characterised in that the information system (2) is locally connected with the user.

32. A system as claimed in claim 30, characterised in that the information system (2) is remote from the user with whom it is connected by means of a telecommunications network (28).

33. A system as claimed in claim 32, characterised in that the processing means (4) include a software for interactivity with the telecommunications network (28).

5 34. A system as claimed in claim 33, characterised in that the software for interactivity with the network is Windows CE.

35. A system as claimed in any of the previous claims, characterised in that the processing means (4) include a software for processing and managing information pertaining to the person's physiological state parameters.

1/2

FIG. 1

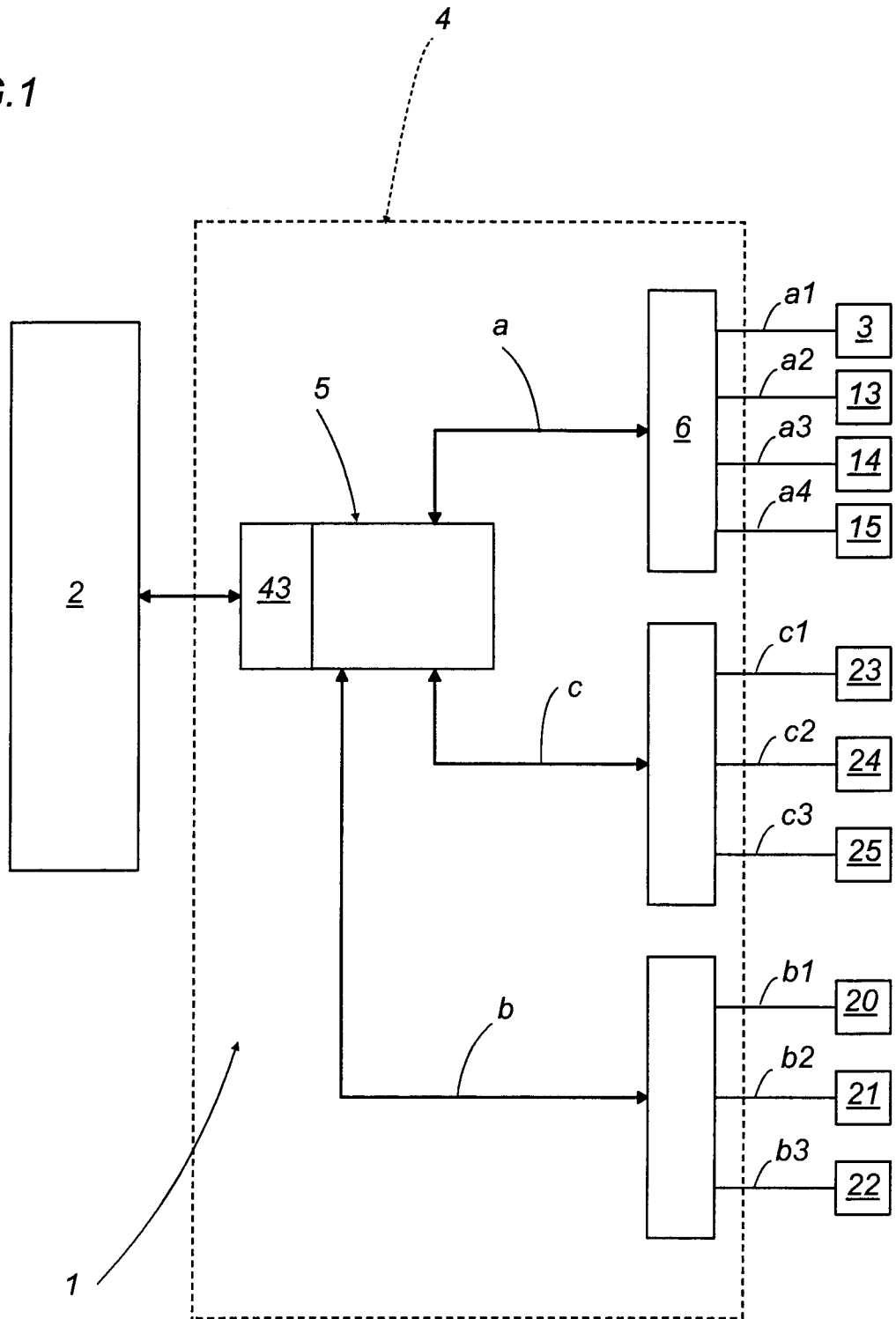

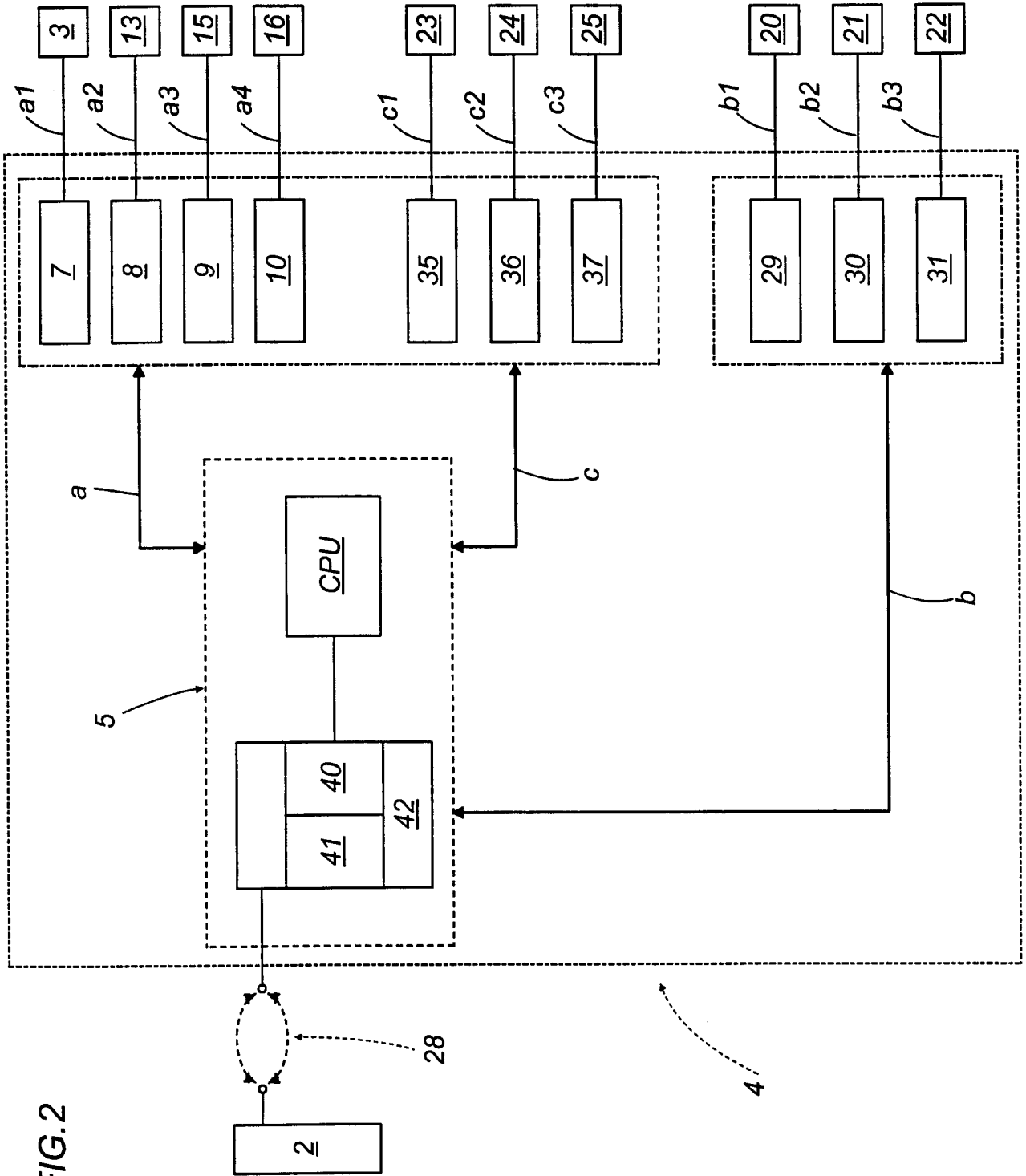

FIG. 2

INTERNATIONAL SEARCH REPORT

Intern. Patent Application No

PCT/IB 00/00460

A. CLASSIFICATION OF SUBJECT MATTER
 IPC 7 A63B24/00 A61B5/00 G06F19/00

According to International Patent Classification (IPC) or to both national classification and IPC

B. FIELDS SEARCHED

Minimum documentation searched (classification system followed by classification symbols)

IPC 7 A63B A61B G06F

Documentation searched other than minimum documentation to the extent that such documents are included in the fields searched

Electronic data base consulted during the international search (name of data base and, where practical, search terms used)

EPO-Internal

C. DOCUMENTS CONSIDERED TO BE RELEVANT

Category °	Citation of document, with indication, where appropriate, of the relevant passages	Relevant to claim No.
X	EP 0 710 465 A (HEWLETT-PACKARD) 8 May 1996 (1996-05-08) column 4, line 8 -column 16, line 37 -----	1-8, 14, 16, 18, 19, 22-26, 30-33, 35
X	WO 97 11753 A (HEIDECHE) 3 April 1997 (1997-04-03) page 11, line 15 -page 16, line 17 -----	1-8, 10, 13-31, 35
X	US 5 546 943 A (GOULD) 20 August 1996 (1996-08-20) column 3, line 28 -column 7, line 37 -----	1, 3-8, 10, 12

Further documents are listed in the continuation of box C.

Patent family members are listed in annex.

° Special categories of cited documents :

- *A* document defining the general state of the art which is not considered to be of particular relevance
- *E* earlier document but published on or after the international filing date
- *L* document which may throw doubts on priority claim(s) or which is cited to establish the publication date of another citation or other special reason (as specified)
- *O* document referring to an oral disclosure, use, exhibition or other means
- *P* document published prior to the international filing date but later than the priority date claimed

- *T* later document published after the international filing date or priority date and not in conflict with the application but cited to understand the principle or theory underlying the invention
- *X* document of particular relevance; the claimed invention cannot be considered novel or cannot be considered to involve an inventive step when the document is taken alone
- *Y* document of particular relevance; the claimed invention cannot be considered to involve an inventive step when the document is combined with one or more other such documents, such combination being obvious to a person skilled in the art.
- *&* document member of the same patent family

Date of the actual completion of the international search

11 July 2000

Date of mailing of the international search report

18/07/2000

Name and mailing address of the ISA

European Patent Office, P.B. 5818 Patentaan 2
 NL - 2280 HV Rijswijk
 Tel. (+31-70) 340-2040, Tx. 31 651 epo nl,
 Fax: (+31-70) 340-3016

Authorized officer

Lemercier, D

INTERNATIONAL SEARCH REPORT

information on patent family members

Intern. Appl. No.

PCT/IB 00/00460

Patent document cited in search report		Publication date	Patent family member(s)	Publication date
EP 710465	A	08-05-1996	US 5579775 A JP 8214379 A	03-12-1996 20-08-1996
WO 9711753	A	03-04-1997	AU 4894296 A	17-04-1997
US 5546943	A	20-08-1996	NONE	

专利名称(译)	一种用于在物理人和信息系统之间交换生理状态信息的电信系统		
公开(公告)号	EP1087824A1	公开(公告)日	2001-04-04
申请号	EP2000914334	申请日	2000-04-13
[标]申请(专利权)人(译)	泰诺健股份公司		
申请(专利权)人(译)	TECHNOGYM S.R.L.		
当前申请(专利权)人(译)	TECHNOGYM S.R.L.		
[标]发明人	ALESSANDRI NERIO		
发明人	ALESSANDRI, NERIO		
IPC分类号	A63B69/00 A61B5/00 A63B24/00 G06F19/00		
CPC分类号	A61B5/0002 A63B24/00 G06F19/3418 G06F19/3481 Y10S128/903 Y10S128/904		
优先权	101999900752454 1999-04-16 IT		
其他公开文献	EP1087824B1		
外部链接	Espacenet		

摘要(译)

一种用于在物理人和信息系统(2)之间交换关于生理状态的个人化参数的信息的电信系统包括:用于测量身体人的生理参数的测量装置(3)以及与所述测量装置(3)和所述信息系统(2)互连的处理装置(4),用于向所述信息系统(2)传送至少对应于由所述人获取的生理参数的输入信号(a1)向所述物理人传输与从所述信息系统(2)返回接收的信息相对应的输出信息(b;c)。电信系统(1)允许物理人和信息系统(2)之间的对话以科学上准确和个性化的方式控制他/她自己的身体状况。