



(12) **EUROPEAN PATENT APPLICATION**

(43) Date of publication:
24.06.2020 Bulletin 2020/26

(51) Int Cl.:
A61N 1/375 (2006.01) A61N 1/372 (2006.01)
A61N 1/362 (2006.01) A61B 5/00 (2006.01)
H04B 13/00 (2006.01) A61N 1/36 (2006.01)

(21) Application number: **19154497.2**

(22) Date of filing: **30.01.2019**

(84) Designated Contracting States:
AL AT BE BG CH CY CZ DE DK EE ES FI FR GB GR HR HU IE IS IT LI LT LU LV MC MK MT NL NO PL PT RO RS SE SI SK SM TR
 Designated Extension States:
BA ME
 Designated Validation States:
KH MA MD TN

(72) Inventors:
 • **Baru, Marcelo**
Tualatin, OR Oregon 97062 (US)
 • **Taff, Brian M.**
Portland, OR Oregon 97217 (US)
 • **Kibler, Andrew B.**
Lake Oswego, OR Oregon 97035 (US)

(30) Priority: **18.12.2018 US 201862780954 P**

(74) Representative: **Engelhardt, Björn**
Biotronik Corporate Services SE
Corporate Intellectual Property
Sieversufer 7 - 9
12359 Berlin (DE)

(71) Applicant: **BIOTRONIK SE & Co. KG**
12359 Berlin (DE)

(54) **CAPACITOR-DISCHARGE COMMUNICATION SCHEME FOR AN IMPLANTABLE MEDICAL SYSTEM**

(57) The present disclosure relates to an implantable medical system (1) for intra-body communication, comprising: an implantable first device (2) comprising a plurality of capacitors (102), wherein the first device (2) is configured to discharge said capacitors (102) in an en-

coded sequence to generate a signal (S), and particularly an implantable second device (3), wherein the second device (3) is configured to receive said signal (S) and to use the information contained in said signal (S) for performing a function.

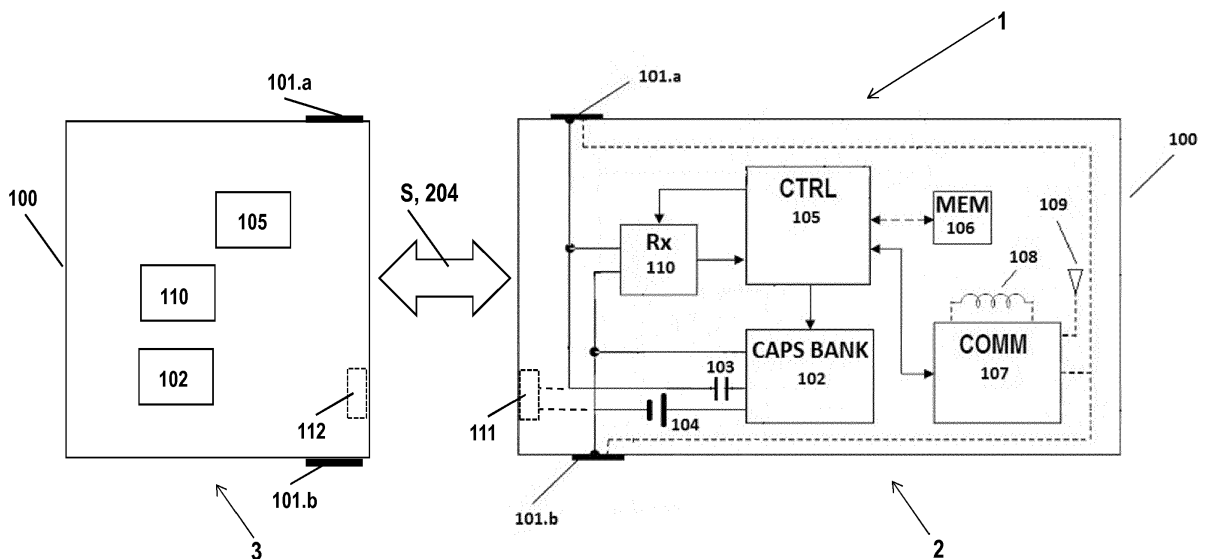

Fig. 1

Description

[0001] The present disclosure relates to an implantable medical system.

[0002] Medical systems, in particular those involving implantable devices, can benefit from intra-body communication for synchronized operation.

[0003] Particularly, document US 9,522,280 B2 discloses dual implanted leadless pacemakers, one in the right atrium and one in the right ventricle, with conductive communication between them.

[0004] Furthermore, document US 9,289,612 B2 discloses an implantable medical system, configured to provide atrio-synchronous ventricular pacing, comprising a first leadless pacing device located in the right ventricle with a sensing extension and a second leadless pacing device implanted in the right atrium. This second device can sense intrinsic depolarizations of the atrium and deliver a pacing pulse during the refractory period of the right atrium following a sensed intrinsic depolarization. The first leadless pacing device in the right ventricle is capable of detecting such pacing pulse generated by the second leadless pacing device and deliver a pacing pulse to the right ventricle an atrio-ventricular (AV) delay interval after detecting such pacing pulse from the second leadless pacing device should an intrinsic ventricular depolarization not be detected prior to the expiration of the AV delay.

[0005] Furthermore, document US 2015/0335894 A1 describes a distributed leadless implantable system that comprises first and second leadless implantable medical devices (LIMDs) configured to be implanted entirely within first and second chambers of the heart, wherein each LIMD comprises a housing having a proximal end configured to engage local tissue in a local chamber, electrodes located along the housing and cardiac sensing circuitry configured to detect intrinsic and paced cardiac events occurring in a near field associated with the local chamber.

[0006] When considering techniques for coordinating ventricular pacing with intrinsic depolarization in another chamber of the heart by delivering an electrical pulse in the other chamber and sensing it in the ventricle, as described in document US 9,289,612 B2, a drawback may be encountered when a pacing pulse is delivered in the refractory period of the other chamber following a sensed intrinsic depolarization in such chamber and that the pacing pulse is detected by the sensing module of the ventricular leadless pacemaker via the adjustment of its sensitivity only. This would imply that a detection of the pacing pulse utilizes the same frequency bandwidth as for cardiac sensing. This means low frequency and thus a long time constant for balancing the charge introduced in the other chamber by the signaling pacing pulse.

[0007] Further, when using implant-to-implant event messaging by conductive communication utilizing a series of individual pulses, as e.g. described in document US 9,522,280 B2, which may include for example a low

frequency pulse followed by a high frequency pulse train, delivered after a sensed event in a chamber it can prove intricate to provide a proper charge balancing of these pulses for the receiver sense amplifier in the other chamber not to pick up artifacts from the communication pulses and confuse them with an intrinsic event in such chamber the receiver implant monitors. Also here, a long time constant may become an issue as described above as the same pulse generator for pacing is utilized for conductive communication. Further, utilizing a conductive high frequency train of pulses with μ s on/off bits as described in document US 9,522,280 B2 translates into substantial extra power consumption in the right ventricle leadless pacemaker as the communication receiver amplifier of such device may be required to be on up to 80% of the time listening for a possible message that an atrial event occurred.

[0008] Based on the above it is an objective to provide a low-power intra-body communication scheme suitable for implementation in small implantable devices whose signaling can particularly coincide with any ongoing intrinsic tissue depolarization that may occur.

[0009] Therefore, an implantable medical system for intra-body communication is disclosed comprising at least an implantable first device comprising a plurality of capacitors (e.g. a bank of capacitors), wherein the first device is configured to discharge said capacitors in an encoded sequence to generate a signal for intra-body communication, e.g. for communication with a second implantable device. The capacitors may be connected in series.

[0010] Particularly, the system enables efficient close-proximity device-to-device communication for use in leadless implantable cardiac rhythm management (CRM) systems. For this, the invention includes a plurality of capacitors which are discharged in an encoded sequence, resulting in a signal in a reception band of an additional implantable device in the body. Encoded sequence means that the capacitors are discharged in a sequence which delivers information to the receiving unit (the second implantable device).

[0011] Particularly, the system can comprise an implantable second device, wherein the second device is configured to receive said signal and use the information contained or coded therein for performing a function.

[0012] According to an embodiment, said second device is a cardiac pacemaker, wherein said function corresponds to delivering an additional pacing pulse to the heart of a patient or inhibiting pacing of a heart of a patient.

[0013] Furthermore, according to an embodiment, the first device is configured such that a maximum charge accumulated in each of the capacitors of the plurality of capacitors is sub-threshold to nerve stimulation or cardiac stimulation of a patient when discharged in tissue of the patient.

[0014] Particularly, according to a preferred embodiment, the first device is configured to passively charge

balance each individual discharge of said sequence of discharges, wherein particularly said sequence is comprised of non-capturing (sub-threshold) discharges for communication.

[0015] Further, according to an embodiment, said capacitors of the plurality of capacitors are configured to be charged to a voltage of a battery of the first device or to a reduced voltage generated from the voltage of a battery of the first device.

[0016] Further, according to an embodiment, the first device (particularly in case said reduced voltage is used) is configured to charge the plurality of capacitors which may be connected in series and to discharge them in said encoded sequence one at a time in parallel.

[0017] Furthermore, in an embodiment, the first device comprises a direct current (DC) blocking capacitor, wherein the first device is configured to discharge said plurality of capacitors in an encoded sequence via said DC blocking capacitor. Particularly, according to an embodiment, the DC blocking capacitor comprises a capacity in the range from 60 nF to 100 nF. Particularly, the DC blocking capacitor can comprise a capacity that amounts to 82 nF.

[0018] Further, according to an embodiment, the first device comprises a control unit configured to manage the plurality of capacitors, wherein particularly the control unit is configured to control charging and/or discharging of the plurality of capacitors, particularly for intra-body communication.

[0019] Furthermore, according to an embodiment, the first device comprises a memory, wherein particularly the control unit is connected to the memory.

[0020] Further, in an embodiment, the first device comprises a communication unit, wherein particularly the control unit is connected to the communication unit.

[0021] Further, according to an embodiment, the communication unit is configured to one of: communicate via said signal due to said discharge of the plurality of capacitors in said encoded sequence; communicate via an inductor of the first device; and communicate in a wireless fashion via an antenna of the first device (i.e. radio communication). Such a communication of the communication unit may be used for programming and/or interrogating the implanted first device using an external programmer. The second device may also incorporate the communication capabilities mentioned above (depending on the therapy application).

[0022] Furthermore, according to an embodiment, each capacitor of said plurality (or bank) of capacitors comprises a capacity in the range from 10 nF to 20 nF, particularly 15 nF.

[0023] Further, in an embodiment, the first device comprise two electrodes configured for contacting tissue of a patient when the first device is implanted in the patient, wherein the first device is configured to discharge said capacitors in the encoded sequence in tissue of the patient via said electrodes to generate said signal. Particularly, the signal is sub-threshold to nerve stimulation or

cardiac stimulation of the patient.

[0024] Furthermore, in an embodiment, the first device is configured to discharge said plurality of capacitors in said encoded sequence such that a waveform is created between the two electrodes of the first device in the tissue of the patient, the waveform comprising a plurality of peaks, wherein the respective peak corresponds to a discharge of a capacitor of said plurality of capacitors during said sequence, and wherein each peak is followed by a charge balancing phase, particularly generated by the first device in a passive manner (i.e. autoshort).

[0025] Furthermore, the implantable second device of the system (or further implantable devices of the system) is configured to receive said signal via two electrodes of the second device, and to extract the peaks of said waveform and convert the respective peak into a corresponding high digital output.

[0026] Further, in an embodiment, the second device comprises a control unit, wherein the control unit of the second device is configured to use a timing between the high digital outputs generated by the second device to determine that an event has been communicated by the first device via said signal.

[0027] Furthermore, according to an embodiment, the first device is configured to shift the timing between said peaks so as to communicate information (e.g. to the second device) in addition to the occurrence of said event.

[0028] Particularly, the second device can comprise a non-linear pre-processor to extract said signal, and particularly to enhance a difference between the peaks and a noise level.

[0029] Furthermore, according to an embodiment, the pre-processor is configured to use an exponential relationship between a gate-source voltage and a drain current of a MOS transistor operating in weak inversion to convert the waveform to a current that is comparable to a threshold. Furthermore, said the non-linear pre-processor can be followed by a current-based comparator for converting the peaks into digital outputs.

[0030] Furthermore, according to an alternative embodiment, the non-linear processor consists of or comprises a differentiator and a squaring circuit.

[0031] Furthermore, according to an embodiment, a total power consumption of a receiver unit of the second device (or of the first device) configured to receive said signal is lower than 100 nA @ 1.5 V.

[0032] Furthermore, according to an embodiment, the first device is a first pacemaker that is configured to be implanted in the right atrium of the patient, and wherein the second device is a second pacemaker that is configured to be implanted in the right ventricle of the patient, wherein particularly the two pacemakers together are configured to operate in the DDD(R) mode (DDD(R): The pacemaker records both atrial and ventricular rates and can pace either chamber when needed, and the pacemaker has a sensor that records a demand for higher cardiac output and can adjust the heart rate accordingly).

[0033] Furthermore, according to an embodiment, one

of the first and the second device (e.g. the first device) is an intracardiac pacemaker (e.g. a leadless pacemaker) and the other device (e.g. the second device) is an implantable loop recorder configured to monitor at least one physiological signal of a patient, such as e.g. an electrocardiogram (ECG), wherein particularly the loop recorder is configured to communicate via wireless radio communication (e.g. according to a Bluetooth standard) with an external device.

[0034] Furthermore, according to an embodiment, one of the first and the second device (e.g. the first device) is an intracardiac pacemaker (e.g. a leadless pacemaker) and the other device (e.g. the second device) is an implantable cardioverter-defibrillator (ICD).

[0035] Furthermore, according to an embodiment, the first device is configured to discharge said plurality of capacitors in said encoded sequence into a communication element of the first device.

[0036] Particularly, the communication element can be a coil that is configured to emit a magnetic field forming said signal in response to discharging said plurality of capacitors in said encoded sequence into the coil, and wherein, according to an embodiment, the second device comprises a coil configured to detect said signal.

[0037] Alternatively, the communication element can be a piezoelectric element that is configured to emit a pressure wave forming said signal in response to discharging said plurality of capacitors in said encoded sequence into the piezoelectric element. In an embodiment, the second device comprises a piezoelectric detector configured to detect said signal.

[0038] In the following embodiments, features and advantages of the present invention shall be explained with reference to the Figures, wherein

Fig. 1 shows a schematic illustration of an embodiment of an implantable medical system;

Fig. 2 shows a waveform of the signal as transmitted by the first device (A) and as received by the second device (B), wherein (C) shows a digital signal as transmitted from the first device (A) and received by the second device (B), wherein (C) shows a digital output of the second device generated from the received signal (B);

Fig. 3 shows embodiments of a non-linear pre-processor of the first or second device; and

Fig. 4 illustrates some analog switches in the capacitor bank.

[0039] Particularly, the present disclosure provides a communication scheme utilizing passively-charge-balanced, non-capturing capacitive discharges that permits at least two implantable devices 2, 3 to communicate with each other. A bank of capacitors 102, charged to the implantable first device's 2 battery 104 voltage or a re-

duced voltage generated from it, are preferably discharged in tissue in an encoded sequence. The receiving second device 3 may utilize a non-linear amplifier to extract the message (see e.g. below). Advantageously, the communication generated according to the various embodiments is low-power and due to the low-value of capacitors required, is suitable for implementation using silicon-integrated passive technology.

[0040] Particularly, the present disclosure allows efficient close-proximity device-to-device communication, particularly for use with implantable leadless pacemakers or loop recorders that do not comprise flexible electrode leads extending from a housing. Instead, leadless pacemakers have a pacing electrode configured to deliver pacing pulses to the patient, wherein the pacing electrode is arranged on the housing. Particularly, such pacemakers are configured to be implanted into an atrium or ventricle of the patient.

[0041] Particularly, as shown in Fig. 1, the implantable medical system 1 according to an embodiment comprises at least a first and a second implantable device 2, 3 and includes a plurality of capacitors (e.g. a bank of capacitors, wherein the capacitors are connected in series) 102 which are discharged in an encoded sequence, resulting in a signal S in a reception band of the second device (or several additional devices) 3 in the body of the patient. The second device 3 / additional devices preferably use the information in the encoded capacitive-discharge communication to perform functions which may include delivering additional pacing pulses or inhibiting pacing.

[0042] A block diagram of a module 100 of the first device 2 comprising a galvanic-coupling communication scheme, is shown in Fig. 1 on the right hand side. Via at least two electrodes 101.a, 101.b, with electrical contact to living tissue of the patient, the first device 2 discharges a bank of capacitors (CAPS BANK) 102, via a DC blocking capacitor 103, that were previously charged to a voltage of a battery 104 of the first device 2 (e.g. 3.6 V maximum, which also powers the rest of the module 100) or to a lower voltage generated from such battery 104. In the latter case, a preferred approach is to charge the capacitors 102 in series and discharge them one at a time in parallel. In this way, each may have a ratio of the battery 104 voltage (e.g. 1/2, 1/3, 1/4, etc.).

[0043] Particularly, module 100 of the first device 2 comprises a control unit (CTRL) 105 that is configured to manage the plurality of capacitors 102. The control unit 105 may be further connected to a memory (MEM) 106 and to a communication unit (COMM) 107. The latter may utilize intra-body galvanic communication (e.g. Z-Comm) via the electrodes 101.a, 101.b, coil-based communication via inductor 108, or radio frequency (e.g. Bluetooth) wireless communication via antenna 109. This permits programming and interrogating the implanted device 2 using an external programmer.

[0044] In a preferred embodiment, each capacitor in the bank 102 has a nominal value of 15 nF. This implies

the maximum charge accumulated in each of these capacitors, to be discharged in tissue for transmitting the occurrence of an intrinsic sensed event, can be made sub-threshold to nerve/cardiac stimulation. The preferred pattern of discharges 200 that may start with a sensed intrinsic tissue depolarization is shown in Figure 2. The same module 100, of at least another (here second) implantable device 3 of the medical system 1, different from the transmitting first device 2, enables a receiver unit 110 connected to its contacts 101.a, 101.b to detect the galvanic-signaled event S (cf. e.g. Fig. 1 left hand side).

[0045] As shown in Fig. 2, the trace 200 is the waveform created between electrodes 101.a, 101.b of transmitting module 100 of the first device 2 upon the discharge 200.a of the bank of capacitors 102 in tissue and associated charge balance phases 200.b, when this bank of capacitors 102 is charged to a battery 104 voltage of 2.5 V for example. Given the small value of these capacitors in bank 102, DC blocking capacitor 103 can be in the order of 82 nF which permits fast charge balance phases 200.b in preparation for the next capacitor discharge 200.a. Trace 201, on the other hand, is the attenuated conducted signal received at contacts 101.a, 101b of the receiver (Rx) unit 110 of module 100 of the second device 3. Trace 202 corresponds to the digital output of the receiver (Rx) unit 110 of the second device 3.

[0046] In yet another embodiment, the timing 203 between the high digital outputs 202 permit control unit 105 of the second device 3 to determine an event 204 has been communicated by transmitting module 100 of the first device 2. Further, by shifting the timing 203 between pulses 200.a in the capacitive discharge transmission 200, several bits of information can be communicated beyond the occurrence of event 204, without adding to the energy required. Examples may include transmitting sensed amplitude information, battery status information, etc.

[0047] Further, to minimize power consumption of the receiving module 100 of the second device 3, the receiver unit 110 comprises a non-linear pre-processor 300 to extract waveform 200.a, enhancing the difference between these peaks 200.a and the noise level, followed by a current-based comparator 301 as shown in Figure 3. In a preferred embodiment, pre-processor 300 uses the exponential relationship between gate-source voltage and drain current of a MOS transistor operating in weak inversion to convert the waveform 200.a to a current 302 that can be compared to a threshold I_{Thr} 303 (cf. Fig. 3(A)). In an alternative embodiment, non-linear processor 300 consists of a differentiator (implemented by capacitor 304) and a squaring circuit 305 instead (cf. Fig. 3(B)). In a preferred embodiment, the total power consumption of the receiver (Rx) unit 110 is lower than 100 nA @ 1.5 V.

[0048] Particularly, the galvanic-communication scheme according to the present disclosure permits implementing a medical system 1 with distributed implanted devices 2, 3, for example: i) two leadless pacemakers,

one implanted in the right atrium and another one in the right ventricle for implementing the functions of a DDD(R) pacemaker; ii) a leadless pacemaker in communication with a subcutaneous loop recorder with Bluetooth® capabilities; iii) a leadless pacemaker in communication with a subcutaneous implantable cardioverter-defibrillator (ICD).

[0049] In other embodiments, the capacitor bank 102 is charged as described, but discharged into a communication element 111 in module 100 of the first device 2, such as a coil or piezoelectric element. The coil 111 will emit a magnetic field which will be detected via a coil 112 in an adjacent receiving device 3, and the piezoelectric element 111 will emit a pressure wave per capacitor discharge which is detectable via a piezoelectric detector 112 in the receiving device 3. In each of these examples, the bank of capacitors (CAPS BANK) 102 is used to charge from the battery 104 and store energy for communication, and communication is facilitated by sequential capacitor discharges to a communication element 111.

[0050] Figure 4 illustrates the analog switches required in the capacitor bank 102 showing two capacitors 102.a and 102.b for simplicity. Analog switches 400, 401 (e.g. transistors) permit charging capacitors 102.a and 102.b to battery voltage 104. By utilizing analog switches 401.a, 402, and 400.b the capacitors 102.a and 102.b can be charged in series to a voltage lower than battery voltage 104. To discharge capacitor 102.a in tissue via electrodes 101.a, 101.b to generate peak 200.a for example, analog switches 403.a, 404.a are closed. Vice versa, to discharge capacitor 102.b, analog switches 403.b and 404.b are closed instead. To perform each charge balancing 202.b, analog switch 205 is closed.

[0051] The disclosed intra-body communication scheme is suitable for implementation in reduced-size implantable devices, such as leadless pacemakers and loop recorders, as the bank of capacitors 102 is suited for integrated-passive technology and does not require stepping up the battery voltage.

Claims

1. An implantable medical system (1) for intra-body communication, comprising an implantable first device (2) comprising a plurality of capacitors (102), wherein the first device (2) is configured to discharge said capacitors (102) in an encoded sequence to generate a signal (S).
2. The implantable medical system (1) according to claim 1, wherein a maximum charge accumulated in each of the capacitors of said plurality of capacitors (102) is sub-threshold to nerve stimulation or cardiac stimulation of a patient when discharged in tissue of the patient.

3. The implantable medical system (1) according to claim 1 or 2, wherein the capacitors of said plurality of capacitors (102) are configured to be charged to a voltage of a battery (104) of the first device (2) or to a reduced voltage generated from the voltage of said battery (104) of the first device (2).
4. The implantable medical system (1) according to any one of the preceding claims, wherein the first device (2) comprises a DC blocking capacitor (103), wherein the first device (2) is configured to discharge said plurality of capacitors (102) in an encoded sequence via said DC blocking capacitor (103).
5. The implantable medical system (1) according to claim 4, wherein the DC blocking capacitor (103) comprises a capacity in the range from 60 nF to 100 nF, particularly 82 nF.
6. The implantable medical system (1) according to any one of the preceding claims, wherein the first device (2) comprises a control unit (105) configured to control the plurality of capacitors (102), wherein particularly the control unit (105) is configured to control charging and/or discharging of the plurality of capacitors (102).
7. The implantable medical system (1) according to any one of the preceding claims, wherein each capacitor of said plurality of capacitors (102) comprises a capacity in the range from 10 nF to 20 nF, particularly 15 nF.
8. The implantable medical system (1) according to any one of the preceding claims, wherein the first device (2) comprises two electrodes (101.a, 101.b) configured for contacting tissue of a patient when the first device (2) is implanted in the patient, wherein the first device (2) is configured to discharge said capacitors (102) in said encoded sequence in tissue of the patient via said electrodes (101.a, 101.b) to generate said signal (S).
9. The implantable medical system (1) according to claim 8, wherein the first device (2) is configured to discharge said plurality of capacitors (102) in said encoded sequence such that a waveform (200) is created between the two electrodes (101.a, 101.b) of the first device (2) in the tissue of the patient, the waveform (200) comprising a plurality of peaks (200.a), wherein the respective peak (200.a) corresponds to a discharge of a capacitor of said plurality of capacitors (102), and wherein each peak (200.a) is followed by a charge balancing phase (200.b).
10. The implantable medical system (1) according to any one of the preceding claims, wherein the system (1) comprises an implantable second device (3) that is configured to receive said signal (S) and to use the information contained in said signal (S) for performing a function.
11. The implantable medical system (1) according to claim 10, wherein the second device (3) is configured to receive said signal (S) via two electrodes (101.a, 101.b) of the second device (3), to extract the peaks (200.a) of said waveform (200), and to convert the respective peak (200.a) into a corresponding high digital output (202).
12. The implantable medical system (1) according to claim 11, wherein the second device (3) comprises a control unit (105), wherein the control unit (105) of the second device (3) is configured to use a timing (203) between the high digital outputs (202) to determine that an event (204) has been communicated by the first device (2) via said signal (S).
13. The implantable medical system (1) according to claim 12, wherein the first device (2) is configured to shift the timing (203) between the peaks (200.a) so as to communicate information in addition to the occurrence of event (204).
14. The implantable medical system (1) according to claim 13, wherein the second device (3) comprises a non-linear pre-processor (300) to extract said waveform (200), and particularly to enhance a difference between the peaks (200.a) and a noise level.
15. The implantable medical system (1) according to one of the claims 1 to 7, wherein the first device (2) is configured to discharge said plurality of capacitors (102) in said encoded sequence into a communication element (111) of the first device (2).

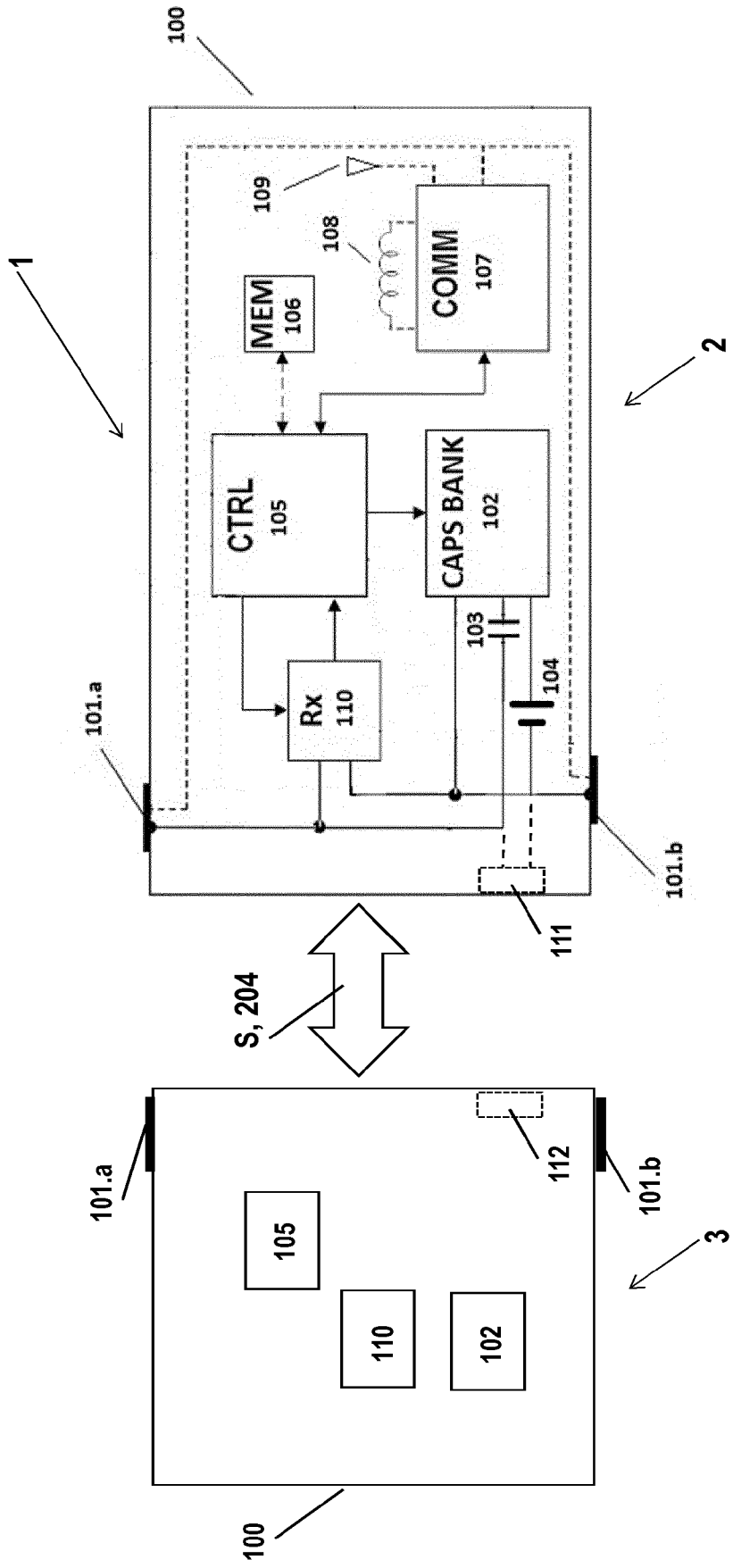

Fig. 1

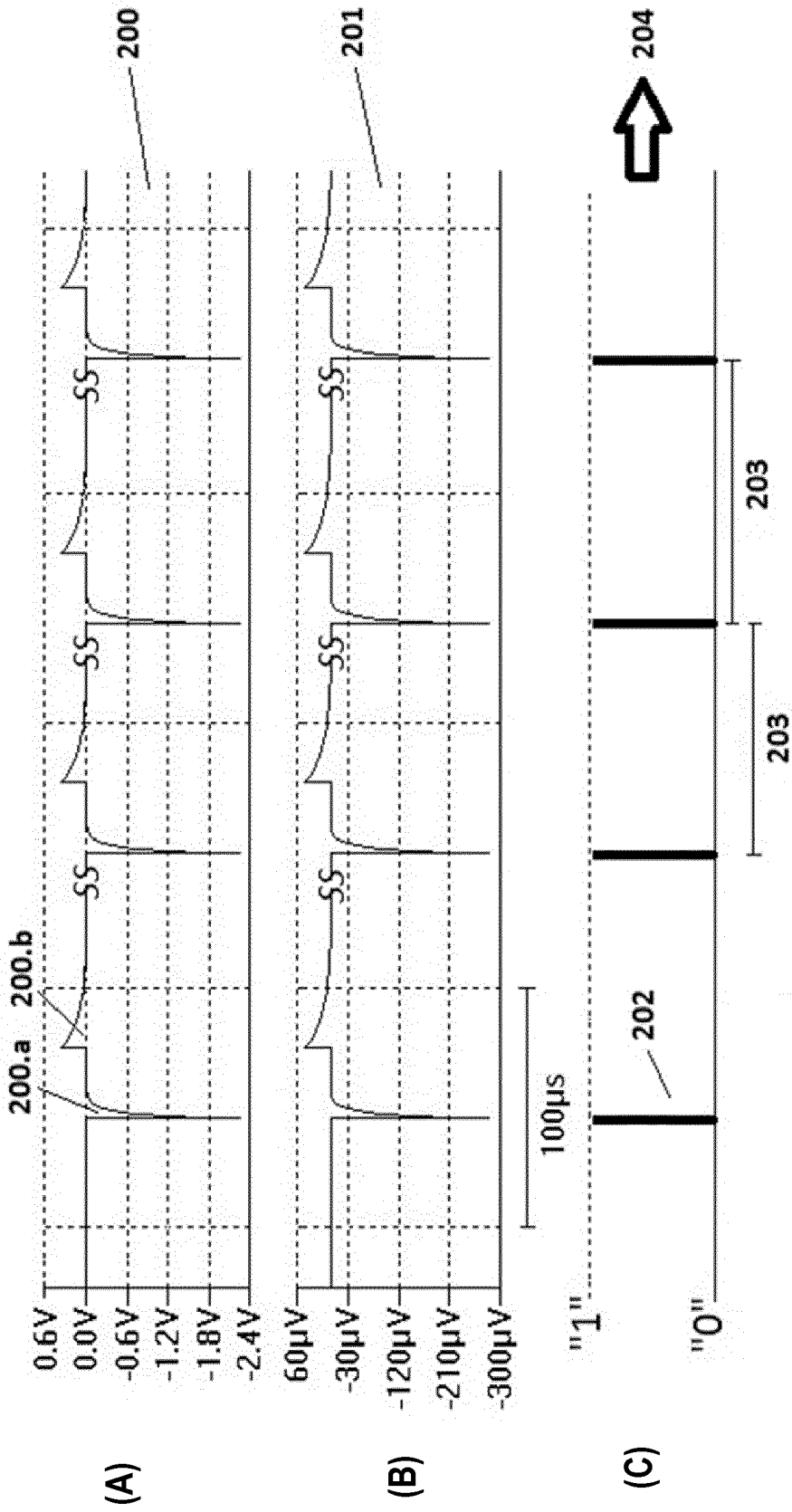

Fig. 2

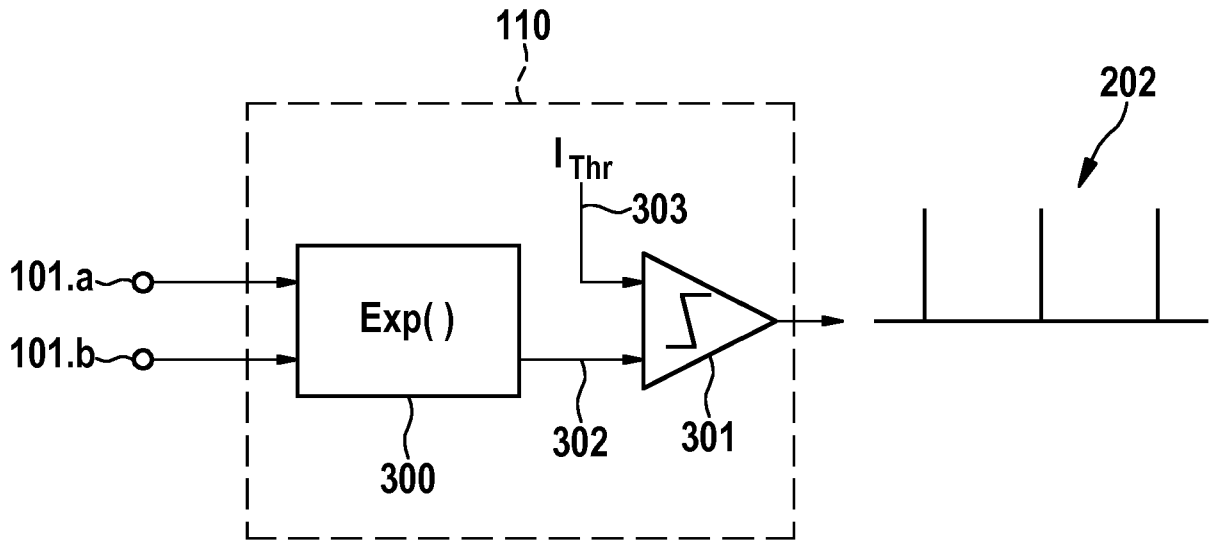

FIG. 3A

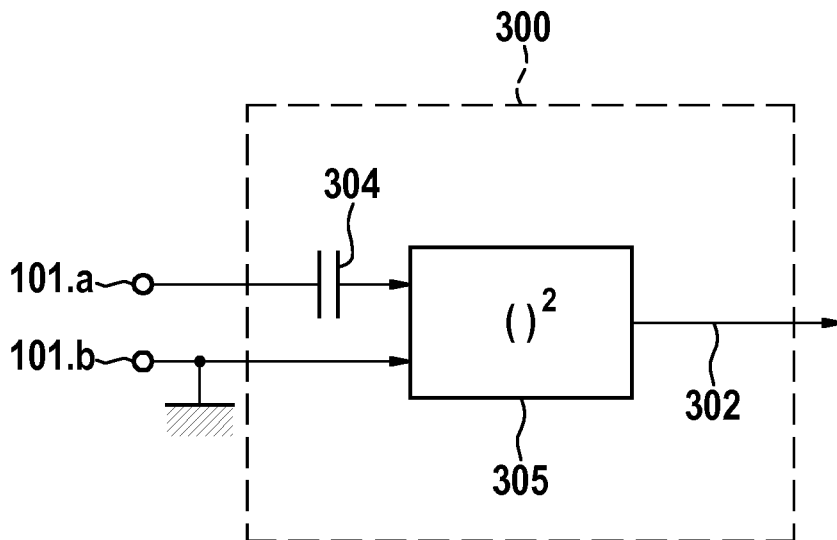

FIG. 3B

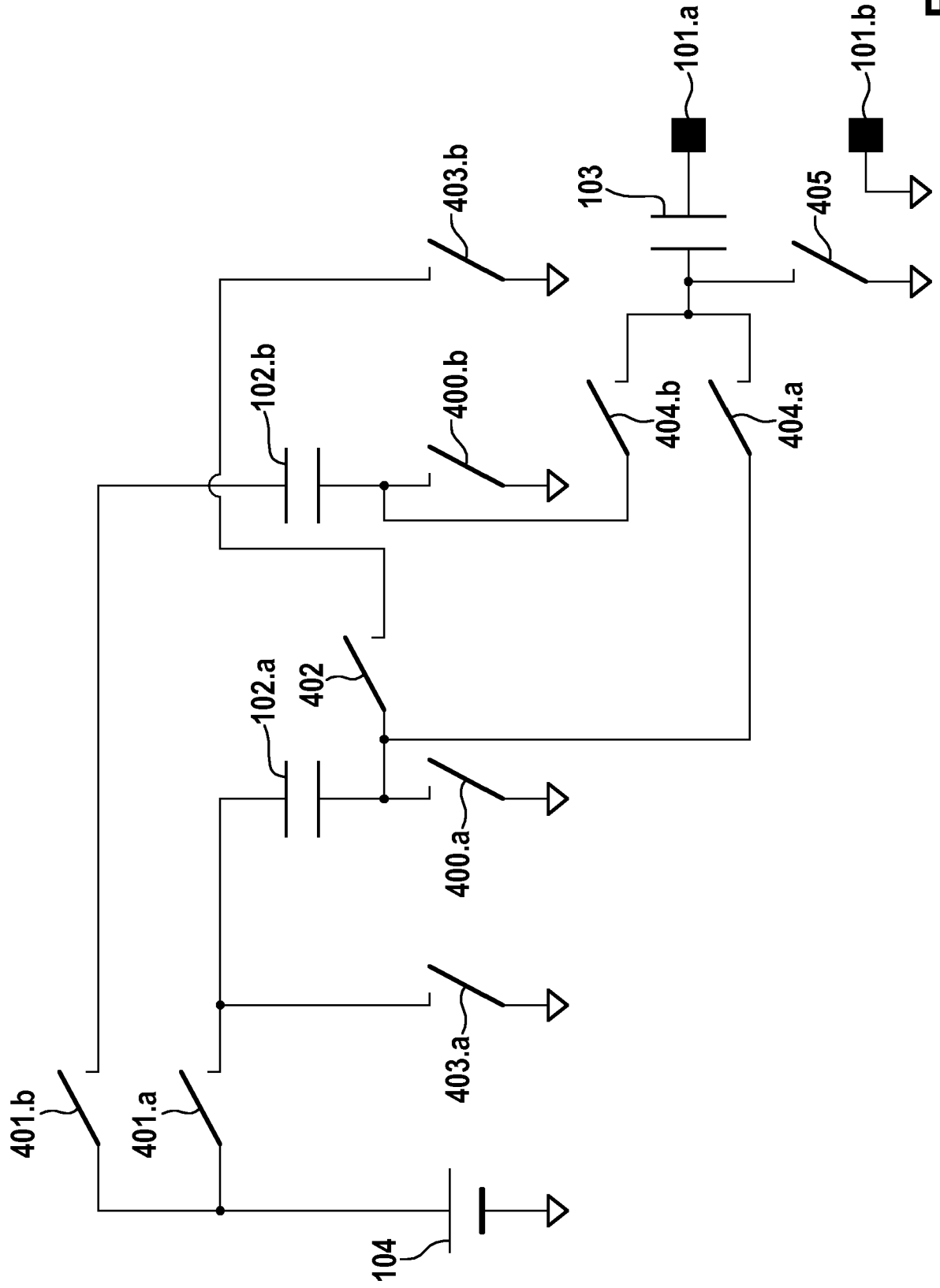

FIG. 4



EUROPEAN SEARCH REPORT

Application Number
EP 19 15 4497

5

10

15

20

25

30

35

40

45

50

55

DOCUMENTS CONSIDERED TO BE RELEVANT			
Category	Citation of document with indication, where appropriate, of relevant passages	Relevant to claim	CLASSIFICATION OF THE APPLICATION (IPC)
X	US 2012/078322 A1 (DAL MOLIN RENZO [FR] ET AL) 29 March 2012 (2012-03-29) * paragraphs [0058] - [0061]; figures 5-8 *	1-15	INV. A61N1/375 A61N1/372 A61N1/362 A61B5/00 H04B13/00 A61N1/36
X	US 2016/213939 A1 (CARNEY JAMES K [US] ET AL) 28 July 2016 (2016-07-28) * paragraphs [0096] - [0113]; figures 6A-6B *	1-15	
X	US 2016/213937 A1 (REINKE JAMES D [US] ET AL) 28 July 2016 (2016-07-28) * paragraphs [0006], [0054] *	1	
A	WO 2016/022395 A1 (CARDIAC PACEMAKERS INC [US]) 11 February 2016 (2016-02-11) * figures 6A-6D *	1-15	
			TECHNICAL FIELDS SEARCHED (IPC)
			A61N A61B H04B
The present search report has been drawn up for all claims			
Place of search Munich		Date of completion of the search 14 June 2019	Examiner Gentil, Cédric
CATEGORY OF CITED DOCUMENTS X : particularly relevant if taken alone Y : particularly relevant if combined with another document of the same category A : technological background O : non-written disclosure P : intermediate document		T : theory or principle underlying the invention E : earlier patent document, but published on, or after the filing date D : document cited in the application L : document cited for other reasons & : member of the same patent family, corresponding document	

EPO FORM 1503 03.82 (P04C01)

ANNEX TO THE EUROPEAN SEARCH REPORT
ON EUROPEAN PATENT APPLICATION NO.

EP 19 15 4497

5

This annex lists the patent family members relating to the patent documents cited in the above-mentioned European search report. The members are as contained in the European Patent Office EDP file on The European Patent Office is in no way liable for these particulars which are merely given for the purpose of information.

14-06-2019

10

Patent document cited in search report	Publication date	Patent family member(s)	Publication date
US 2012078322 A1	29-03-2012	EP 2433675 A1 US 2012078322 A1	28-03-2012 29-03-2012
US 2016213939 A1	28-07-2016	US 2016213939 A1 WO 2016118847 A1	28-07-2016 28-07-2016
US 2016213937 A1	28-07-2016	US 2016213937 A1 US 2018056080 A1 WO 2016118845 A1	28-07-2016 01-03-2018 28-07-2016
WO 2016022395 A1	11-02-2016	AU 2015301351 A1 CN 106794352 A EP 3177363 A1 JP 6487030 B2 JP 2017522980 A US 2016038747 A1 WO 2016022395 A1	16-02-2017 31-05-2017 14-06-2017 20-03-2019 17-08-2017 11-02-2016 11-02-2016

15

20

25

30

35

40

45

50

55

EPO FORM P0459

For more details about this annex : see Official Journal of the European Patent Office, No. 12/82

REFERENCES CITED IN THE DESCRIPTION

This list of references cited by the applicant is for the reader's convenience only. It does not form part of the European patent document. Even though great care has been taken in compiling the references, errors or omissions cannot be excluded and the EPO disclaims all liability in this regard.

Patent documents cited in the description

- US 9522280 B2 [0003] [0007]
- US 9289612 B2 [0004] [0006]
- US 20150335894 A1 [0005]

专利名称(译)	用于可植入医疗系统的电容器放电通信系统		
公开(公告)号	EP3669935A1	公开(公告)日	2020-06-24
申请号	EP2019154497	申请日	2019-01-30
申请(专利权)人(译)	BIOTRONIK SE & CO.KG		
当前申请(专利权)人(译)	BIOTRONIK SE & CO.KG		
[标]发明人	BARU MARCELO TAFF BRIAN M KIBLER ANDREW B		
发明人	BARU, MARCELO TAFF, BRIAN M. KIBLER, ANDREW B.		
IPC分类号	A61N1/375 A61N1/372 A61N1/362 A61B5/00 H04B13/00 A61N1/36		
CPC分类号	A61B5/0028 A61N1/36038 A61N1/3622 A61N1/3627 A61N1/3628 A61N1/37217 A61N1/37223 A61N1/37252 A61N1/3727 A61N1/37276 A61N1/37288 A61N1/3756 H04B13/005 H02J7/345		
优先权	62/780954 2018-12-18 US		
外部链接	Espacenet		

摘要(译)

本公开涉及一种用于体内通信的可植入医疗系统 (1)，包括：包括多个电容器 (102) 的可植入第一设备 (2)，其中第一设备 (2) 被配置为对所述电容器 (102) 以编码序列生成信号 (S)，尤其是可植入的第二设备 (3)，其中第二设备 (3) 配置为接收所述信号 (S)，并使用包含在所述信号中的信息 (S) 用于执行功能。

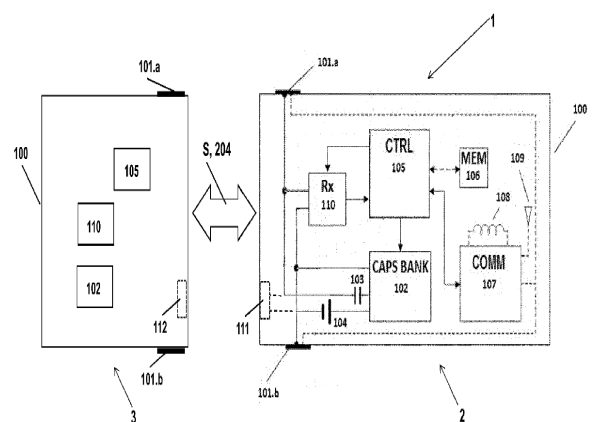

Fig. 1