



(11) **EP 3 387 991 A1**

(12) **EUROPEAN PATENT APPLICATION**

(43) Date of publication:  
**17.10.2018 Bulletin 2018/42**

(51) Int Cl.:  
**A61B 5/0424** (2006.01) **A61B 5/0408** (2006.01)  
**A61B 5/00** (2006.01) **A61B 5/0478** (2006.01)

(21) Application number: **18175409.4**

(22) Date of filing: **12.05.2011**

(84) Designated Contracting States:  
**AL AT BE BG CH CY CZ DE DK EE ES FI FR GB GR HR HU IE IS IT LI LT LU LV MC MK MT NL NO PL PT RO RS SE SI SK SM TR**

- **DAY,, Mark, J.**  
**San Francisco, CA California 94103 (US)**
- **PARK,, Shena, H.**  
**San Francisco, CA California 94103 (US)**
- **WILLIS,, William, F.**  
**San Francisco, CA California 94103 (US)**
- **RIGHTER,, William, H.**  
**San Francisco, CA California 94103 (US)**

(30) Priority: **12.05.2010 US 33408110 P**

(62) Document number(s) of the earlier application(s) in accordance with Art. 76 EPC:  
**11781310.5 / 2 568 878**

(74) Representative: **Potter Clarkson LLP**  
**The Belgrave Centre**  
**Talbot Street**  
**Nottingham NG1 5GG (GB)**

(71) Applicant: **Irhythm Technologies, Inc.**  
**San Francisco, CA 94103 (US)**

- (72) Inventors:
- **KUMAR,, Uday, N.**  
**San Francisco, CA California 94103 (US)**
  - **LIVINGSTON,, Peter, H.**  
**San Francisco, CA California 94103 (US)**

Remarks:

This application was filed on 31.05.2018 as a divisional application to the application mentioned under INID code 62.

(54) **DEVICE FEATURES AND DESIGN ELEMENTS FOR LONG-TERM ADHESION**

(57) There is provided an electronic device for long-term adhesion to a mammal, the device comprising: a flexible first wing and a flexible second wing extending laterally from a housing without overlapping, wherein each wing includes a hinge portion adjacent the housing; a first electrode positioned on the bottom surface of the first wing and a second electrode positioned on the bottom surface of the second wing, the electrodes electronically connected to a rigid physiologic data collection circuit;

an adhesive layer on the bottom surface of each wing, the adhesive layer providing adhesion to the surface of the mammal; and a floating section forming a water-tight enclosure and comprising the rigid physiologic data collection circuit, the floating section configured to float above the surface of the mammal in response to movement of the mammal; wherein the rigid physiologic data collection unit extends along only a portion of the distance between the electrodes.

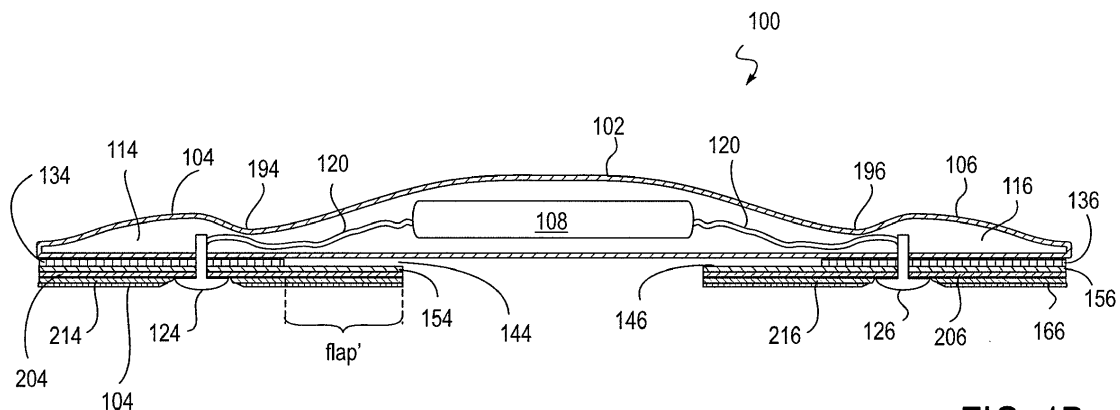

**FIG. 1B**

**EP 3 387 991 A1**

**Description****CROSS-REFERENCE TO RELATED APPLICATIONS**

[0001] This application claims priority to U.S. Provisional Patent Application No. 61/334,081, filed May 12, 2010, entitled "Device Features and Design Elements for Long-Term Adhesion," which is incorporated by reference as if fully set forth herein.

**INCORPORATION BY REFERENCE**

[0002] All publications and patent applications mentioned in this specification are herein incorporated by reference to the same extent as if each individual publication or patent application was specifically and individually indicated to be incorporated by reference.

**FIELD OF THE INVENTION**

[0003] This application relates to devices worn on a body for monitoring, recording, reporting and/or treating the person wearing the device. Improvements in the device design elements and functionality are disclosed for maintaining the device in contact with and operational for extended periods of time, typically longer than 24 hours.

**BACKGROUND OF THE INVENTION**

[0004] The ability to adhere a medical device to a human body for a long-period of time is dependent on a variety of factors. In addition to the type and nature of the adhesive chosen, another factor is the mechanical design of the device. By design, this refers to, but is not limited to, the device shape, size, weight, flexibility, and rigidity. These design elements are influenced by a number of additional factors, including, but not limited to, where on the body the device will attach and the duration of the attachment, moisture conditions in that area, movement conditions in that area, stretching and contraction in that area, interactions with external factors in that area such as clothing, and purposeful and/or inadvertent interaction between the person wearing the device and the device.

[0005] As many devices are typically used on the body for less than 24 hours, devices have not been designed that can withstand longer-term adhesion. Hence, there is a need to implement device features and design elements that have the ability to enhance the likelihood of adhesion of a device to a human body for 24 hours or more, while accommodating the functionality, shape, size, weight, flexibility, and rigidity of a given device.

**SUMMARY OF THE INVENTION**

[0006] In one aspect of the invention, there is an electronic device for long-term adhesion to a mammal. The

device has a housing containing an electronic component with a first wing and a second wing integrally formed with the housing. There is an electrode positioned on a bottom surface of each of the wings with the electrodes electrically connected to the electronic component. An adhesive layer is provided for adhesion to a surface of the mammal. The adhesive layer is coated on a portion of the bottom surface of the wings. The adhesive layer is not coated on the electrode or on a bottom surface of the housing.

[0007] The electronic component in any of the devices described herein may include a processor having a memory with computer readable instructions to record signals from the first and second electrodes while the electronic device is attached to the mammal. The processor may be configured to only convert signals from the electrodes to digital signals, filter those signals and then store the signals in memory.

[0008] In another aspect, the device includes a flap connected to each of the wings. The flaps may extend below the housing. Additionally or alternatively, the adhesive layer is coated on a bottom surface of the flaps.

[0009] In another aspect, the device includes a connector segment. In one aspect, the connector segment configured to connect the flaps together. In other aspects, the connector segment is located at least partially below the housing. Still further, the connector segment is not attached to the housing.

[0010] In one alternative, the adhesive layer is coated on a bottom surface of the flap.

[0011] In still another aspect, the adhesive for adhesion to a surface of the mammal is an adhesive that can absorb fluids. In another aspect, the adhesive that can absorb fluids is a hydrocolloid adhesive. In another aspect, the adhesive for adhesion to a surface of the mammal is a pressure-sensitive adhesive. The pressure sensitive adhesive is selected from the group consisting of: a polyacrylate, a polyisobutylene, and a polysiloxane. In one alternative, the device includes a diffusion barrier between the adhesive layer and each of the wings. The device may also include an additional adhesive layer and material layer between the wing and the adhesive layer for adhesion to the mammal. The material layer is configured to prevent diffusion of adhesive components from the adhesive layer to the wing. The diffusion barrier may be made from polyester or other suitable synthetic material.

[0012] In one aspect of the device, all or substantially all of the electronic components are within the housing. In another aspect, the wing is free from electronic components. In one aspect, the wing is more flexible than the housing. In one alternative, the wings and the housing are made from the same material. In another aspect, the wings and the housing are made from different materials. In another, the wings are made from a fabric. In still another aspect, the material used to make the wings includes a synthetic fiber. In another alternative, the wing and the flap are composed of the same material.

**[0013]** In another alternative, the device includes a hinge portion between the housing the wing. The hinge portion is configured to allow the device to bend between the housing and the wing. In one aspect, the hinge portion exists between a rigid portion of the device and a flexible portion of the device. In one alternative, the rigid portion of the device corresponds to the portion of the housing including the electronics and the flexible portion of the device includes a wing.

**[0014]** In one aspect, the bottom surface of the wing and the bottom surface of the flap are contiguous. In another aspect, the bottom surfaces of the wings, the flap, and the connectors are contiguous. In still other aspects, the flaps and the connector are contiguous.

**[0015]** In another aspect, the connector has at least one hole extending it. The hole may have any of a number of shapes such as circular, oval, round, or triangular.

**[0016]** In one aspect, the housing is thicker at a center of the housing than at edges of the housing.

**[0017]** In another aspect of the device, the housing is unattached to the mammal when the electrodes are in contact with the mammal.

**[0018]** In another alternative aspect of a device for long-term adhesion to a mammal, the device includes a housing with a first wing extending laterally from the housing and a second wing extending laterally from the housing without overlapping the first wing. There is a first electrode positioned on a bottom surface of the first wing and a second electrode positioned on a bottom surface of the second wing. An electronic memory is positioned within the housing. The electronic memory is configured to receive and store electronic signals from the first and second electrodes while the electronic device is attached to the mammal. There is also an adhesive layer on a portion of a bottom surface of the first wing and the second wing. The adhesive is not on a bottom surface of the housing. When the device is worn on the mammal, only the adhesive layer(s) are attached to the mammal.

**[0019]** In one aspect, the portion of the bottom surface of the first wing and the second wing does not include the first and second electrodes. In one device aspect, the first wing, the second wing, and the housing are formed from the same material. In still another, the first wing, the second wing and the housing integrally form a monolithic structure. In other aspects, an angle formed by the first wing, the second wing, and the housing is between approximately 90° and 180°. In one variation, the angle is approximately 180°. In another variation, the angle is approximately 135°.

**[0020]** In still other embodiments, there is a first hinged portion between the first electrode and the processor and a second hinged portion between the second electrode and the housing.

**[0021]** In a further aspect, at least a portion of the body uncovered is not adhered to the mammal when signals from the electrodes are being recorded in memory.

**[0022]** In another aspect, the device includes a first flap connected to the first wing medial to the first electrode

and a second flap connected to the second wing medial to the second electrode. Each flap may extend below the housing.

**[0023]** The device may also include a connector segment configured to connect the flaps together. In one aspect, the connector segment is located at least partially below the housing, but is not attached to the housing.

**[0024]** In another aspect, there is an electronic device that has a patch including a housing containing an electronic component. There is an electrode positioned on a bottom surface of the patch, the electrode electrically connected to the electronic component. There is a first adhesive strip extending around the perimeter of the patch and a second adhesive strip extending around the perimeter of the first adhesive strip. In one aspect, the first adhesive cover over the first adhesive strip and a second adhesive cover over the second adhesive strip. The first and second adhesive covers may be configured to be separably removed from the first and second adhesive strips. In one alternative, the first adhesive strip extends between the first and second adhesive covers. In another alternative, the adhesive in the first and the second adhesive strips is an adhesive that can absorb fluids. In still another aspect, the adhesive that can absorb fluids is a hydrocolloid adhesive. In one alternative, the adhesive in the first and the second adhesive is a pressure-sensitive adhesive. In some aspects, the pressure-sensitive adhesive is a polyacrylate, a polyisobutylene, or a polysiloxane.

**[0025]** In one alternative, the second adhesive strip partially overlaps the first adhesive strip. In another aspect, the second adhesive strip is attached to a shell, the shell overlapping the first adhesive strip.

**[0026]** In still another alternative device for long-term adhesion to a mammal, the device includes a patch having a housing with an electronic component contained therein. There is an electrode positioned on a bottom surface of the patch. The electrode electrically connected to the electronic component. There is a porous foam pad configured to be positioned between the electronic component and the mammal. In one aspect, the porous foam pad comprises a biocompatible foam material. In one variation, the porous foam pad can absorb fluids. In still another aspect, the porous foam pad is attached to the housing. In another, the porous foam pad is configured to be attached to the mammal. In another request, the porous foam pad can absorb fluids.

**[0027]** In one aspect of a method of applying an electronic device, there is a step of removing a first adhesive cover from the first wing of the electronic device to expose an electrode and an adhesive coated on a bottom surface of a first wing. There is a step of placing the exposed electrode into contact with the mammal by adhering the adhesive coated bottom of the first wing to the mammal. There is also a step of removing a second adhesive cover from the second wing of the electronic device to expose an adhesive coated on a bottom surface of the second wing and another exposed electrode. There is also a step

of placing the another exposed electrode into contact with the mammal by adhering the adhesive coated bottom of the second wing to the mammal. After performing the removing and the placing steps, the housing is unattached to the mammal, but is held in position on the mammal using the adhesive coated bottoms of the first and the second wings.

**[0028]** In one alternative method of attaching a device, the electronic device includes a first flap connected to the first wing and a second flap connected to the second wing. The first and second flaps each extend below the housing. The step of removing a first adhesive cover from the first wing may also include exposing an adhesive coated on a bottom surface of the first flap. The step of removing a second adhesive cover from the second wing may also include exposing an adhesive coated on a bottom surface of the second flap.

**[0029]** In another alternative method of attaching a device, after performing the removing and the placing steps, the housing is held in position on the mammal using only the adhesive coated bottoms of the first wing, the second wing, the first flap and the second flap.

**[0030]** In an alternative aspect of a method of applying an electronic device to a mammal for long-term adhesion, the method includes removing a first adhesive cover from the first wing of the electronic device to expose an electrode and an adhesive coated on a bottom surface of the first wing. There is also a step of removing a second adhesive cover from the second wing of the electronic device to expose an adhesive coated on a bottom surface of the second wing and another exposed electrode. There is a step of placing the exposed electrodes into contact with the mammal by adhering the adhesive coated on the bottom of the first and the second wings to the mammal. After performing the removing and the placing steps, the housing is unattached to the mammal, but is held in position on the mammal using the adhesive coated bottoms of the first and the second wings.

**[0031]** There is also provided a method of applying an electronic device to a mammal for long-term adhesion wherein the electronic device includes a patch. The patch includes an electronic component along with an electrode positioned on a bottom surface of the patch and electrically connected to the electronic component. There is a first adhesive strip extending around the perimeter of the patch and a second adhesive extending around the perimeter of the first adhesive strip. One aspect of a method of applying the device includes a step of removing an adhesive cover from the second adhesive strip of the electronic device. There is a step of applying pressure to the second adhesive strip to adhere the second adhesive strip to the mammal such that the electrode is in contact with the mammal. Then, after a period of time, removing an adhesive cover from the first adhesive strip of the electronic device. Next, there is the step of applying pressure to the first adhesive strip to adhere the first adhesive strip to the mammal such that the electrode remains in contact with the mammal.

**[0032]** In another alternative method of applying an electronic device to a mammal for long-term adhesion, the electronic device includes a patch, an electronic component, and an electrode positioned on a bottom surface of the patch and electrically connected to the electronic component. There is a first adhesive strip extending around the perimeter of the patch. The method includes a step of applying pressure to a first adhesive strip to adhere the first adhesive strip to the mammal such that the electrode is in contact with the mammal. After a period of time, placing a second adhesive strip around the perimeter of the first adhesive strip. Then there is the step of applying pressure to the second adhesive strip to adhere the second adhesive strip to the mammal such that the electrode remains in contact with the mammal.

**[0033]** Any of the above described devices may include additional aspects. A device may also include a first wire connecting the first electrode and the processor or an electronic memory and a second wire connecting the second electrode and the processor or an electronic memory. The first and second wires extend within the body and the first and second wings. In one aspect, the first and second wires extend within and are completely encapsulated within the body and the first and second wings. In one aspect, a conduit is provided within the body and the wings and the wires pass through the conduit. In one alternative, the conduit extends from the processor or electronic memory to an electrode so that the wire is completely within the conduit. In still other aspects of the devices described above, the first and second wires connecting the electrodes to the processor or electronics each include slack between the electrode and the processor. In one aspect, the slack is located in a portion of each wing that is configured to bend or flex. In another aspect, the slack is a portion of the wire within the wing and at least partially coiled about the first or the second electrode. In still other aspects, the slack is provided by a portion of the wire formed into a coil, a wave pattern, or a sinusoidal pattern along its length the connection point on the electronics to the connection point on the electrode.

**[0034]** In still other alternatives, the devices described above may be applied to any of a wide variety of conventional physiological data monitoring, recording and/or transmitting devices. Any of the improved adhesion design features and aspects may also be applied to conventional devices useful in the electronically controlled and/or time released delivery of pharmacological agents or blood testing, such as glucose monitors or other blood testing devices. Additional alternatives to the devices described may include the specific components of a particular application such as electronics, antenna, power supplies or charging connections, data ports or connections for down loading or off loading information from the device, adding or offloading fluids from the device, monitoring or sensing elements such as electrodes, probes or sensors or any other component or components needed in the device specific function. In still other aspects,

the electronic component in any of the above devices is an electronic system configured for performing, with the electronic signals of the mammal detected by the electrodes, one or more or any combination of or the following electronic functions: monitoring, recording, analyzing, or processing using one or more algorithms electronic signals from the mammal. Still further, any of the devices described above may include appropriate components such that the device is used to detect, record, process or transmit signals or information related to signals generated by a mammal to which the device is attached including but not limited to signals generated by one or more of EKG, EEG and/or EMG.

## BRIEF DESCRIPTION OF THE DRAWINGS

**[0035]** The novel features of the invention are set forth with particularity in the claims that follow. A better understanding of the features and advantages of the present invention will be obtained by reference to the following detailed description that sets forth illustrative embodiments, in which the principles of the invention are utilized, and the accompanying drawings of which:

FIG. 1 is a top view of a patch having two wings;  
 FIG. 1A is a representative cross-section of an embodiment of the patch in FIG. 1;  
 FIG. 1B is a representative cross-section of another embodiment of the patch in FIG. 1;  
 FIG. 1C is a representative cross-section of another embodiment of the patch in FIG. 1;  
 FIG. 1D is a representative cross-section of another embodiment of the patch in FIG. 1;  
 FIG. 1E is a representative cross-section of another embodiment of the patch in FIG. 1;  
 FIG. 1F is a top view of a patch having three wings illustrating an alternative electrode-electronics-electrode orientation;  
 FIG. 2A is a schematic drawing of the electronics contained within a patch;  
 FIG. 2B is a schematic drawing of a patch with wiring having slack in the form of undulations between electronics and electrodes;  
 FIG. 2C is a schematic drawing of a patch with wiring having slack in the form of a coil between electronics and electrodes;  
 FIG. 3 is the bottom view of a patch having adhesive thereon;  
 FIG. 4A shows a patch as worn by a person rolled to the side;  
 FIG. 4B shows a patch as worn by a person playing golf;  
 FIG. 5A shows a patch in response to a concave bend of the skin;  
 FIGS. 5B and 5C show a patch in response to a convex bend of the skin;  
 FIG. 6A is a bottom view of a patch having a connector between two flaps;

FIG. 6B is a cross-section of the patch of FIG. 6A;  
 FIG. 7A is a bottom view of a patch having multiple covers forming strips of adhesive;  
 FIG. 7B is a cross-section of the patch of FIG. 7A;  
 FIG. 8A is a bottom view of a patching having multiple covers forming strip of adhesive around each electrode;  
 FIG. 8B is a cross-section of the patch of FIG. 8A;  
 FIGS. 9A and 9B show a patch having multiple layers formed thereon;  
 FIGS. 10A and 10B show a patching having multiple layers formed thereon, each layer having multiple patches of adhesive;  
 FIG. 11 shows a patch having an open cell support;  
 FIG. 12 shows a patch having an annular open cell support;  
 FIG. 13A shows a patch having a protective shell thereon; and  
 FIG. 13B shows a cross-section of the patch of FIG. 13A.

## DETAILED DESCRIPTION

**[0036]** The following device features and design elements can be implemented into any device being adhered to the human body for a long-period of time, typically greater than 24 hours. As an example, the following device features and design elements can be used for long-term adhesion of a cardiac rhythm monitoring patch ("patch") to the chest of a person.

**[0037]** Referring to FIGS. 1 and 1A, a patch 100 for long term adhesion includes a housing 102. The housing 102 can be formed from any flexible, durable material, such as a biocompatible polymer, for example silicone. The housing 102 can include electronic components 108 therein. As shown in FIG. 2, the electronics 108 can include a printed circuit board 220, a battery 225, and a communications port mounted on the printed circuit board 220. The printed circuit board 220 can include analog circuits 2110, digital circuits 215, and an activation or event notation button or switch 130. The electronics 108 can be used, for example, to record continuous physiological signals from a mammal wearing the patch 100. A system for continuously recording data is described further in co-owned U.S. Application No. 11/703,428, filed February 6, 2007, the entire contents of which are incorporated by reference herein.

**[0038]** As shown in FIGS. 1 and 1A, wings 104, 106 can be connected to the housing 102. The wings 104, 106 can be integral with the housing 102 and, in some embodiments, can be formed of the same material as the housing 102. The wings 102, 104 can be more flexible than the electronic components 108, which can be substantially rigid. An electrode 124, 126 can extend through a bottom surface of each wing 104, 106. The electrodes can be positioned to detect an ECG of a mammal wearing the patch 100 for processing by the electronics 108. For example, the electrodes can be more than 2cm apart,

such as more than 3 cm apart, for example at least 6cm apart. The electrodes 124, 126 can be integral with the wings 104, 106 so as to be inseparable from the wings 104, 106 when the patch is in use.

**[0039]** For a patch 100 that is entirely flexible and can conform, stretch, and adapt to the movement and conditions of the chest underneath the device, adhesive can be placed over the entire surface of the device that is in contact with the body, except for areas where sensors, electronics, or others elements such as electrodes are interacting with the body related to the functioning of the device may be incorporated. Thus, as shown in FIG. 3, an adhesive layer 164, 166 can coat the bottom of the patch 100 for attachment to the skin. For a patch 100 in which there may be some areas that are not completely flexible and may not be able to stretch or contract (e.g., the electronics 108), adhesive may be excluded from the portion of the patch 100 underneath these areas. Thus, for example, the bottom surface 302 of the housing 102, which contains the electronics, can remain free from adhesive. As shown in FIG. 1A, by not coating adhesive on a bottom surface of the housing 102, the housing 102 can float above the adhered portions, allowing for increased flexibility of the patch, as will be discussed further below. Further, as shown in FIG. 3 the bottom surface of the electrodes 124, 126 can remain free of adhesive. For example, a ring 362 without adhesive can be formed around each electrode 124, 126 to separate the electrodes from the adhesive 164. The adhesive can be, for example, a pressure-sensitive adhesive, such as polyacrylate, polyisobutylene, or a polysiloxane. Alternatively, the adhesive can be a hydrocolloid which advantageously absorbs water.

**[0040]** The wings 104, 106 and the housing 102 can form a smooth, contiguous outer surface to the patch 100. As shown in FIG. 1A, when viewed from the top, the housing 102 and wings 104, 106 can together form an oblong substantially oval shape. Further, the housing 102 can have a thickness that is greater than the thickness of the wings 104, 106. The housing 102 and each of the wings 104, 106 when viewed in profile, can each form a dome with a height that is greater at the center than at the ends of the respective component, i.e., some or all of the components can be tapered at the ends and/or sides.

**[0041]** The electronics 108 can extend along only a portion of the distance between the electrodes 104, 106. For example, the electronics can occupy less than 90% of the distance between the electrodes, for example less than 80%. By having the electronics 108 in a relatively limited space between the electrodes 124, 126, the flexibility of the patch 100 can be increased.

**[0042]** The housing 102 can provide a watertight enclosure 110 for electronic components 108 of the patch 100. The electronics 108 can be unattached to the housing 102 such that the electronics 108 are free to move within the watertight enclosure 110. Allowing the relatively rigid electronics 108 to move freely within the flexible

housing 102 advantageously enhances the overall flexibility of the patch 100. The wings 104, 106 can each have a watertight enclosure 114, 116 formed therein, which can be contiguous with the watertight enclosure 110 of the housing 102.

**[0043]** Wiring 120 or other suitable electrical connections can connect the electrodes 124, 126 with the electrical components 108 of the housing. In some embodiments, as shown in FIGS. 1B-1E, the contiguous nature of the enclosure 110 and the enclosures 112, 116 allows the wiring 120 to extend within the patch 100 from the electrodes 124, 126 to the electronic components 108. In other embodiments, one or more channels, tubes, or conduits are provided between the housing 102 and the wings 104, 106, to provide space for the wiring 120. The tube or channel may be straight or curved. In use, the wire 120 positioned in the enclosures 110, 112, 116 or in the tube or channel may move relative thereto in order to remain flexible within the housing. In one aspect, the flexible channels or tubes are formed within the device housing so that the housing, as it is being stretched, does not affect the ability of the components, such as wires, that may connect more rigid structures, to move or elongate.

**[0044]** As shown in FIG. 1, the wire 120 is straight with a direct line of connection between the electrodes 124, 126 and the electronics 108. FIG. 1 illustrates an embodiment where the length of the wires 120 connecting the electrodes 124, 126 to electronics 108 are about the same distance as the spacing between the electrode connection point on electronics 108 and the electrodes 124, 126. FIG. 1F also illustrates a straight line type connection where wire 120 length is nearly the same as the spacing between the electronics 108 and the electrodes 124, 126. However, as a patient moves, the patch 100 flexes along with patient movement. As shown in FIGS. 4B and 5C, patch flexion may be severe and is likely to occur during long term monitoring. In order to address the possible dislocation or breakage of the wire 120, the length or shape of the wire 120 may be selected to permit patch flexion to occur with little risk of wire 120 pulling from the electrode or electronics. Numerous alternatives are possible to compensate for patch flexion. Exemplary configurations include undulations or zig-zags 231 as shown in FIG. 2B, coils 233 as shown in FIG. 2C, or a configuration that partially or fully wraps around an electrode. In some embodiments, other components, such as the circuit board or electrodes, can alternatively or additionally contain additional length to help accommodate stretch or displacement. When the patch 100 is attached to a mammal, the slack in the wiring 120 allows the patch 100 to flex while not placing stress on the wiring 120.

**[0045]** While the illustrated embodiments of FIGS. 1A-1D show only two wings and show the electrodes and electronics in a direct line (i.e., in an approximate 180 degree alignment of electrode 124 to electronics 108 to electrode 126), other configurations are possible. For ex-

ample, as shown in FIG. 1F, the wings 104, 106 are arranged in an orientation less than 180 degrees. In the illustrated embodiment, the angle formed by the electrodes and the electronics is about 135 degrees. Other ranges are possible so long as electrode spacing is provided to permit ECG monitoring. The orientation of the wings 104, 106 to the housing 102 also illustrates the use of an additional adhesive tab 105. Tab 105 is shown as a semicircular extension of the body 102. The bottom of tab 105 can include adhesives as described herein and is used to provide additional anchoring of the patch to the patient. The tab 105 may be formed in any of a number of different shapes such as rectangles, ovals, loops or strips. Further, in some embodiments, the tab 105 can function similar to a wing, e.g., include an electrode therethrough that connects to the electronics 108.

**[0046]** Referring to FIGS. 1A-1D and 2B-2C, a hinge portion 194, 196 in the patch 100 can extend between each electrode 124, 126 and the electronics 108. The hinge portions 194, 196 can have a thickness less than the thickness of surrounding portions of the patch 100. For example, if the hinge portions 194, 196 are in the wings 104, 106, then the thickness can be less than adjacent portions of the wings. Likewise, the hinge portions 194, 196 can have a width less than adjacent portions of the patch 100, e.g., less than adjacent portions of the wings 104, 106. Alternatively, the hinged portion can be formed by the adjunct between a rigid portion, i.e. the electronics 108, and a more flexible portion. The hinged portion allows the patch 100 to bend between the housing 102 and wings 104, 106 to compensate for any movement caused by the patient. As shown in FIGS. 2B and 2C, the slack in the wiring 120 can be placed at or proximal to the hinge portions 194, 196 to allow for bending at the hinge portions 194, 196 without pulling or breaking the wiring 120.

**[0047]** Referring to FIGS. 4A and 4B, having adhesive on the bottom of the patch 100 except in the areas substantially around the electrodes and directly underneath the housing 102 can create a floating section 455 over the skin of the mammal to which the patch 100 is attached. The floating section 455 can house the more rigid or less flexible electronic components while the flexible wings 104, 106 can be adhered to the skin and provide the flexibility necessary to hold the patch 100 in place. As a result of this selective use of adhesive areas and non-adhesive areas, the limitation on device flexibility imposed by the less flexible floating section can be mitigated or reduced by bounding the floating section with one or more adhered flexible areas. The flexible sections can thus adhere to the body if the underlying portion of the body is stretched and/or contracted while the floating section is free to move above the skin, for example if the person wearing the device rolls over (as shown in FIG. 4A) or is involved in activities that can otherwise cause movement of the skin (as shown in FIG. 4B).

**[0048]** Referring back to FIGS. 1B-1E, each wing 104, 106 can include a material layer 214, 216 between the

adhesive 164, 166 and the wings 104, 106. The material layer 214, 216 can be, for example, a polyester layer. The material layer 214, 216 can be attached to the patch 100 with a layer of adhesive 204, 206. The adhesive 204, 206 can be the same as the adhesive 164, 166 or different. For example, the adhesive 204, 206 could be a silicone adhesive. The material layer 214 can serve as a barrier to prevent diffusion or migration of adhesive components, such as a tackifier, from the adhesive 164, 166 into the wings 104, 106 or housing 102. The material layer 214 can thus advantageously serve to maintain the strength of the adhesive 104, 106 over time.

**[0049]** Referring still to FIGS. 1B-1E, the patch 100 can further include a first flap 154 connected to the first wing 104 and a second flap 156 connected to the second wing 106. The flaps 154, 156 can both extend from a position on the wings 104, 106 medial to the electrodes to a position below the housing 102, such as below the electronics 108. The flaps 154, 156 can remain unattached to the housing 102. As a result, gaps 144, 146 can be formed between the flaps 134, 136 and the housing 102. The gaps can provide additional "floating" for the housing 102 and the relatively rigid components 108 contained therein.

**[0050]** In some embodiments, shown in FIG. 1B, the flaps 154, 156 can be attached to the wings 104, 106 with adhesive 134, 136. The adhesive 134, 136 can be the same as the adhesive 164, 166 or different. For example, the adhesive 134, 136 could be a silicone adhesive. In other embodiments, shown in FIGS. 1C - 1E, the flaps 154, 156 can be integral with the wings 102, 104. For example, the flaps 154, 156 can be solvent welded to and/or formed during the molding process of the wings 104, 105 such that hinges 184, 186 form below the wings 104, 106. Additionally or alternatively, one or more of the flaps 132, 136 may be separably attached to the wings 104, 106. In some embodiments, shown in FIGS. 1B and 1C, the materials making up the flaps 154, 156 can extend all the way to the lateral edge of the patch 100. In other embodiments, shown in FIG. 1D, a flap can extend on each side of the electrodes, i.e. one flap can extend medially and the other laterally. In some embodiments, the lateral and medial -extending flaps are part of the same annular flap. In other embodiments, shown in FIG. 1E, the flaps and materials making up the flaps extend only from a position medial to the electrodes underneath the housing.

**[0051]** The flaps 154, 156 may be positioned in virtually any relationship to the adhered flexible area such that, when attached in use, the attachment of the flap or flaps effectively counteracts the expected external forces acting on the device, specifically those forces that may dislodge the adhered flexible areas. Further, in embodiments such as that shown in FIG. 1F where there are more than two wings, there can be a flap corresponding to each additional wing.

**[0052]** The adhesive layers 164, 166 can coat all or a portion of the bottom of each of the flaps 124, 126. In

some embodiments, the adhesive 164, 166 extends continuously from the bottom surface of the wings 104, 106 to the bottom surface of the flaps 154, 156, except for areas proximate to the electrodes 124, 126. Further, the top surface of the flaps 154, 156, i.e. the surface closest to the housing 102, can remain free of adhesive to ensure that the housing 102 remains floating. In some embodiments, the only portion of the patch 100 including adhesive for adhesion to the skin can be the flaps 154, 156.

**[0053]** Referring to FIGS. 5A-5C, the flaps 154, 156, can provide hinge-like behavior for the patch 100. Thus, as shown in FIG. 5A, if the skin 501 is stretched or bent in a concave manner, the gaps 144, 146 between the flaps 154, 156 and the housing 102 can approach zero such that the patch 100 can sit substantially flat on the skin 501. As shown, the hinge portions 194, 196 between the housing 102 and wings 104, 106 can provide additional flexibility for concave bends by flattening as the patch 100 is stretched. In contrast, as shown in FIGS. 5B and 5C, as the skin 501 is bent in an increasingly convex manner, the gaps 144, 146 between the flaps 154, 156 and the housing 102 can increase, thereby allowing the flexible wings 104, 106 to remain adhered to the skin and the rigid housing 102 to float above skin. As shown, the hinge portions 194, 196 between the housing and the wings 104, 106 can provide additional flexibility for convex bends by folding inward as the patch 100 is bent.

**[0054]** When placed substantially flat on the skin 501, the patch 100 can have a height that extends no more than 2cm off of the skin, such as no more than 1.5cm off of the skin, when lying flat on the patient and no more than 4 cm, such as no more than 1cm off of the skin when floating above the skin. The relatively low height of the patch 100 can enhance long-term adhesion by reducing the potential for the patch 100 to snag or rip off of the skin.

**[0055]** Advantageously, the flaps 154, 156 can function as anchors for adhesion that mitigates shear force. The flaps 154, 156 can provide a different direction for the acute and chronic forces being experienced by the device due to stretching, contraction, or torsion to be spread out over both the flap as well as the flexible adhesive areas. Further, by pre-aligning the orientation of the floating section, adhered flexible area and the flaps, the device may be better able to tolerate (i.e., remain attached to the body and in use) and/or tailor the interaction with the forces acting on the device in order to better withstand the acute or chronic forces being experienced by the device. Tailoring the response of the device to the expected forces is one factor in improving the likelihood of long-term device adhesion.

**[0056]** Because the flaps can be used to counteract forces acting on a particular device, it is to be appreciated that the dimensions, flexibility, attachment technique, and/or orientation between a flap and another component may vary depending upon the purpose of a particular flap. Accordingly, a flap may have the same or different characteristics from another flap or component of the de-

vice. In one aspect, at least one flap is more flexible than the other flaps in a particular device. In another aspect, each of the flaps has similar flexibility. In still another aspect, at least one flap is more flexible than the device component to which it is attached or from which it originates. In still another aspect, at least one flap is less flexible than the device component to which it is attached or from which it originates.

**[0057]** Referring to FIGS. 6A and 6B, in one embodiment, the flaps 154, 156 may be augmented by a connector segment 607 used to join the flaps together. The connector segment 607 can extend below the housing 102, but remain unattached to the housing 102. As shown in FIG. 6A, the flaps 154, 156 and the connector 607 can together form a butterfly shape. In one embodiment, the connector segment 607 and the flaps 154, 156 are formed from a single piece of material. The connector segment 607 can be made of the same material as the flaps 154, 156 or of different material. In one embodiment, the bottom surface of the connector is covered with adhesive. In another embodiment, the bottom surface of the connector does not include any adhesive. Further, as shown in FIG. 6B, the connector segment 607 can be thicker in the middle, under the housing 102, than near the edges, i.e., closer to the electrodes. The variable thickness can help prevent the connector segment 607 from capturing moisture thereunder. The connector segment 607 can advantageously prevent the device from flipping when attached to the patient.

**[0058]** The connector segment 607 can include one or more holes 614, 616. In some configurations, the connector segment may trap moisture and/or inadvertently stick to the body. The holes 614, 616 can advantageously minimize the potential for undesired sticking or moisture collection. The size, shape and placement of the holes mitigate or reduce the collection of moisture and/or undesired adhesive while still providing a connector with sufficient structural integrity (i.e. the connector allows the flaps to be connected to one another in order to prevent them from folding). Additionally or alternatively, the connector holes could also be made to also preferentially allow forces to be distributed along certain axes of the connector in order to further maximize the ability of the device to adhere long-term in the face of significant acute and chronic forces due to stretching, contraction, and torsion.

**[0059]** Adhesive can be selectively applied to the connector and/or flaps to provide the desired body attachment locations depending upon the specific use of the device. For example, one piece of material including flaps and the connector can be adhered along two or more edges and/or with adhesive only covering certain areas. In another aspect, at least a portion of the skin-contacting surface of the unitary flap connector structure does not include any adhesive. Additionally or alternatively, the connector segment incorporating the flaps may be integral parts of the larger device housing (e.g. could be molded as part of the device housing or enclosure).

**[0060]** In some embodiments, the patch 100 can include one or more release liners to cover parts of the adhesive prior to adhesion. As is particular to devices having multiple adhesive areas and/or multiple adhesive components (i.e., flaps and flexible sections), the manner of applying the device may be specifically detailed in order to ensure that the device and the adhesive portions are properly engaged. In one particular aspect, the release liners are removed in a particular order to minimize the likelihood that the device adhesive is misapplied. For example, a portion of the adhesive may be exposed first and used to affix the device to the body. Thereafter, a second set of adhesive liners may be removed to expose and affix one or more flaps to the body. A stepwise adhesive exposure method may be implemented during device application such that elements, such as the one or more flaps do not fold on themselves, for example.

**[0061]** Breaking up the areas in which the adhesive is used to adhere the device, whether it be splitting it up to rigid areas, to create flaps, to create connector segments with holes, of any of the other techniques described above may also have benefits in terms of preventing moisture bridges that could act as conducting pathways between electrical sensing elements, such as electrodes. Bridges of moisture could short-circuit electrical connections and/or prevent the proper functioning of the device, particularly if the device has an electrical function, such as sensing via electrodes.

**[0062]** In some applications, a long-duration patch may experience excessive forces due to acute (quick and/or rapid) or chronic (slow and/or prolonged) contraction, stretching, or torsion. In such applications, the hinge points between a floating rigid section and flexible adhered sections may be modified in order to align with and counteract or mitigate the predominate direction of the force acting on the patch. In some device situations or configurations, the strength and direction of the acute or chronic force may be so strong that the forces imparted on the device adhesive surfaces or components may be distributed differently in addition to or as an alternative to the hinge described above.

**[0063]** Further, the device construction can be made in such a way that the housing is fashioned so that the axes of the housing are structured and placed along or against the direction of various forces, possibly during certain states, such as sleeping, so that the device itself can help counteract these forces and improve long-term adhesion.

**[0064]** Advantageously, the patch described herein can provide long-term adhesion to the skin. Having the various flexible portions and/or hinged portions can compensate for stressed caused as the skin stretches or bends, while allowing the rigid portion to float about the skin. As a result, the devices described herein can adhere to the skin substantially continuously for more than 24 hours, such as greater than 3 days, for example, greater than 7 days, greater than 14 days, or greater than 21 days.

**[0065]** Another mechanism for adhering a patch to the skin long-term is described with respect to FIGS. 7-10. As shown in the embodiments of FIGS. 7-10, one or more parts of the patch are used in a temporary fashion in order to improve adhesion. The adhesive used in the embodiments described below can include a hydrocolloid or a pressure-sensitive adhesive, such as polyacrylate, polyisobutylenes, or polysiloxane.

**[0066]** In one embodiment, shown in FIGS. 7A and 7B, the patch 700 can be surrounded with an adhesive 760 having multiple covers 701, 703, 705 thereon that can be peeled away in a sequence to expose strips of adhesive 760 underneath. The covers 701, 703, 705 can be concentric with one another and be configured to be pulled off separately and sequentially starting from the inside of the patch 700. Each additional exposed area of adhesive 760 can increase the adhesion life of the patch 700. Although only three covers are shown in FIG. 7A, other numbers, such as 2, 4, 5, or more are possible. Further, each electrode 124, 126 of the patch 700 can include a barrier 714, 716 to protect the electrodes 124, 126 from shortage.

**[0067]** In another embodiment, shown in FIGS. 8A and 8B, each electrode 124, 126 can be surrounded by a patch of adhesive 864, 866. Accordingly, a set of covers 801, 803, 805, 807 can be positioned sequentially around each of the electrodes 124, 126 over the adhesive 864, 866. The covers 801, 803, 805, 807 can be concentric with one another and be configured to be pulled off sequentially starting from the inside. Each additional exposed strip of adhesive 864, 866 can increase the adhesion life of the patch 100. Although only four covers are shown in FIG. 8A, other numbers, such as 2, 3, 5, or more are possible. Further, each electrode 124, 126 of the patch 800 can include a barrier 814, 816 to protect from shortage.

**[0068]** Referring to FIGS. 9A-9B, in other embodiments, shells or layers 901, 902, 903 can extend over all or a portion of the patch 900. Each layer 901, 902, 903 can include a strip of adhesive 962 on the bottom surface and an adhesion guard 982 protecting the adhesive. As shown in FIG. 9B, as the patch 900 is worn over a period of time, the layers 901, 902, 903 can be sequentially removed. As a new layer is exposed, the adhesive guard 982 of that layer can be peeled away such that the adhesive 962 of the new layer can be used to adhere the patch 900 to the skin. In a similar embodiment, referring to FIGS. 10A-10B, each of the layers 1001, 1002, 1003 can include multiple portions of adhesive to help adhere the layer to both the skin and the patch itself. As with the embodiments of FIGS. 7-8, the number of layers in the embodiments of FIGS. 9 and 10 can vary. For example, there can be 2, 3, 4, or 5 or more layers.

**[0069]** In some embodiments, the layers or covers of the embodiments described herein can be added to the device over time to improve adhesion. Further, the multiple layers or covers of the embodiments described herein can be partially overlapped. Further, in some embod-

iments, the strips of adhesive can be overlapped.

**[0070]** Advantageously, the use of multiple covers or layers can assist in the adhesive performance of a base or core device because the added surface area or adhesive force of the combined outer layer aids in preventing layer pull away and/or may act to spread forces being experienced away from the core device by spreading those forces over a larger area

**[0071]** Referring to FIGS. 11 and 12, an open cell structured support 1330 or porous foam can be used to support a more rigid or less flexible portion 1302 of the patch 1300. As shown in FIG. 11, the open cell structured support 1330 can fully fill an area below the rigid portion 1302. Alternatively, as shown in FIG. 12, the open cell structured support 1330 can be an annular shape or have some other configuration that includes spaces between adjacent portions of the support. The open cell structured support 1302 may be attached to both the skin and to the rigid portion, to only the rigid portion, or to only the skin. Because of the open cell structure of the support, the flexible movement of the skin can be absorbed by the structure entirely or partially such that the rigid portion does not impact or has a reduced impact on the ability of the device to accommodate movement and remain affixed. In addition, the open cell support may have a thickness selected to enhance patient comfort so that the more rigid portion of a device does not push against the skin. In one aspect, the open cell structure is a biocompatible foam material. In another aspect, the open cell material is positioned between an electronics module on the device and the skin when worn by a patient. The open cell support can advantageously absorb fluids to keep the electrodes from shorting.

**[0072]** Referring to FIG. 13, the patch can have a shell design. Adhesive can be placed on the perimeter edge of the bottom ring. The circuit board and electrode unit can be dropped into the bottom ring, and a shell can be dropped on top of the circuit board and electrode. The perimeter adhesive can create a watertight chamber therein.

**[0073]** The shape of a particular electronic device embodiment may vary. The shape, footprint, perimeter or boundary of the device may be a circle or circular (see FIG. 13A), an oval (see FIG. 1A, 2A), a triangle or generally triangular (see FIG. 1F) or a compound curve. Examples of a device embodiments having a compound curve shape are shown in FIGs. 2B, 2C, 3, 6A, 7A and 8A. In some embodiments, the compound curve includes one or more concave curves and one or more convex curves. FIG. 3 illustrates a device having a convex surface along the top (where reference 102 indicates), a concave surface along the bottom and convex shaped edges around the electrodes 124, 126. FIGs. 2B and 2C illustrate a device embodiment having a convex shape on either side of the electronics 108 and around the electrodes 124, 126. The convex shapes are separated by a concave portion. The concave portion is between the convex portion on the electronics and the convex portion

on the electrodes. In some embodiments, the concave portion corresponds at least partially with a hinge, hinge region or area of reduced thickness between the body and a wing.

**[0074]** While described in the context of a heart monitor, the device adhesion improvements described herein are not so limited. The improvement described in this application may be applied to any of a wide variety of conventional physiological data monitoring, recording and/or transmitting devices. The improved adhesion design features may also be applied to conventional devices useful in the electronically controlled and/or time released delivery of pharmacological agents or blood testing, such as glucose monitors or other blood testing devices. As such, the description, characteristics and functionality of the components described herein may be modified as needed to include the specific components of a particular application such as electronics, antenna, power supplies or charging connections, data ports or connections for down loading or off loading information from the device, adding or offloading fluids from the device, monitoring or sensing elements such as electrodes, probes or sensors or any other component or components needed in the device specific function. In addition or alternatively, devices described herein may be used to detect, record, or transmit signals or information related to signals generated by a body including but not limited to one or more of EKG, EEG and/or EMG.

**[0075]** Preferred aspects of the present invention are set out in the following numbered paragraphs of the description.

**[0076]** Paragraph 1. An electronic device for long-term adhesion to a mammal, the device comprising:

- 35 a housing having an electronic component contained therein;
- a first wing and a second wing, each wing integrally formed with the housing;
- 40 an electrode positioned on a bottom surface of each of the wings, the electrodes electrically connected to the electronic component; and
- 45 an adhesive layer for adhesion to a surface of the mammal, the adhesive layer coated on a portion of the bottom surfaces of the wings, wherein the adhesive layer is not coated on the electrode or on a bottom surface of the housing.

**[0077]** Paragraph 2. The electronic device of paragraph 1, wherein the electronic component includes a processor within the housing, the processor having a memory with computer readable instructions to record signals from the first and second electrodes while the electronic device is attached to the mammal.

**[0078]** Paragraph 3. The electronic device of paragraph 1, further comprising a flap connected to each wing, the flaps extending below the housing, wherein the adhesive layer is coated on a bottom surface of the flap.

**[0079]** Paragraph 4. The electronic device of para-

graph 3, further comprising a connector segment, the connector segment configured to connect the flaps together.

**[0080]** Paragraph 5. The electronic device of paragraph 4, wherein the connector segment is located at least partially below the housing, but is not attached to the housing.

**[0081]** Paragraph 6. The electronic device of paragraph 4, wherein the adhesive layer is coated on a bottom surface of the flap.

**[0082]** Paragraph 7. The electronic device of paragraph 1, wherein all electronic components are within the housing such that the wing is free from electronic components.

**[0083]** Paragraph 8. The electronic device of paragraph 1, further comprising a hinge portion between the housing and the wing, the hinge portion configured to allow the device to bend between the housing and the wing.

**[0084]** Paragraph 9. The electronic device of paragraph 1, wherein the adhesive for adhesion to a surface of the mammal is an adhesive that can absorb fluids.

**[0085]** Paragraph 10. The electronic device of paragraph 9, wherein the adhesive that can absorb fluids is a hydrocolloid adhesive.

**[0086]** Paragraph 11. The electronic device of paragraph 1 wherein the wings and the housing are made from the same material.

**[0087]** Paragraph 12. The electronic device of paragraph 1 wherein the wings and the housing are made from different materials.

**[0088]** Paragraph 13. The electronic device of paragraph 12 wherein the wings are made from a fabric.

**[0089]** Paragraph 14. The electronic device of paragraph 12 wherein the material used to make the wings includes a synthetic fiber.

**[0090]** Paragraph 15. The electronic device of paragraph 1, wherein the wing is more flexible than the housing.

**[0091]** Paragraph 16. The electronic device of paragraph 3, wherein the bottom surface of the wing and the bottom surface of the flap are contiguous.

**[0092]** Paragraph 17. The electronic device of paragraph 3, wherein the wing and the flap are composed of the same material.

**[0093]** Paragraph 18. The electronic device of paragraph 4, wherein the flaps and the connector are contiguous.

**[0094]** Paragraph 19. The electronic device of paragraph 3, further comprising at least one hole extending through the connector segment.

**[0095]** Paragraph 20. The electronic device of paragraph 1, wherein the adhesive for adhesion to a surface of the mammal is a pressure-sensitive adhesive.

**[0096]** Paragraph 21. The electronic device of paragraph 20 wherein the pressure sensitive adhesive is selected from the group consisting of: a polyacrylate, a polyisobutylene, and a polysiloxane.

**[0097]** Paragraph 22. The electronic device of paragraph 1, wherein the housing is thicker at a center of the housing than at edges of the housing.

**[0098]** Paragraph 23. The electronic device of paragraph 1, further comprising a diffusion barrier between the adhesive layer and each of the wings.

**[0099]** Paragraph 24. The electronic device of paragraph 1 further comprising: an additional adhesive layer and material layer between the wing and the adhesive layer for adhesion to the mammal, the material layer configured to prevent diffusion of adhesive components from the adhesive layer to the wing.

**[0100]** Paragraph 25. The electronic device of paragraph 23 further comprising a polyester diffusion barrier.

**[0101]** Paragraph 26. The electronic device of paragraph 1, wherein the housing is unattached to the mammal when the electrodes are in contact with the mammal.

**[0102]** Paragraph 27. An electronic device for long-term adhesion to a mammal, the device comprising:

a housing;

a first wing extending laterally from the housing;

a second wing extending laterally from the housing without overlapping the first wing;

a first electrode positioned on a bottom surface of the first wing;

a second electrode positioned on a bottom surface of the second wing;

an electronic memory within the housing, the electronic memory configured to receive and store an electronic signal from the first and second electrodes while the electronic device is attached to the mammal; and

an adhesive layer on a portion of a bottom surface of the first wing and the second wing and not on a bottom surface of the housing, wherein when the device is worn on the mammal only the adhesive layer is attached to the mammal.

**[0103]** Paragraph 28. The electronic device of paragraph 27, wherein the portion of the bottom surface of the first wing and the second wing does not include the first and second electrodes.

**[0104]** Paragraph 29. The electronic device of paragraph 27, wherein the first wing, the second wing, and the housing are formed from the same material.

**[0105]** Paragraph 30. The electronic device of paragraph 27, wherein the first wing, the second wing and the housing integrally form a monolithic structure.

**[0106]** Paragraph 31. The electronic device of paragraph 27, wherein an angle formed by the first wing, the second wing, and the housing is between approximately 90° and 180°.

**[0107]** Paragraph 32. The electronic device of paragraph 31, wherein the angle is approximately 180°.

**[0108]** Paragraph 33. The electronic device of paragraph 31, wherein the angle is approximately 135°.

**[0109]** Paragraph 34. The electronic device of para-

graph 27, further comprising a first wire connecting the first electrode and the processor and a second wire connecting the second electrode and the processor, the first and second wires extending within the body and the first and second wings.

[0110] Paragraph 35. The electronic device of paragraph 34, wherein the first and second wires each include slack between the electrode and the processor.

[0111] Paragraph 36. The electronic device of paragraph 35, wherein the slack is located in a portion of each wing that is configured to bend or flex.

[0112] Paragraph 37. The electronic device of paragraph 27, wherein there is a first hinged portion between the first electrode and the processor and a second hinged portion between the second electrode and the housing.

[0113] Paragraph 38. The electronic device of paragraph 27, wherein at least a portion of the body uncovered is not adhered to the mammal when signals from the electrodes are being recorded in memory.

[0114] Paragraph 39. The electronic device of paragraph 27, further comprising a first flap connected to the first wing medial to the first electrode and a second flap connected to the second wing medial to the second electrode, wherein each flap extends below the housing.

[0115] Paragraph 40. The electronic device of paragraph 39, further comprising a connector segment, the connector segment configured to connect the flaps together.

[0116] Paragraph 41. The electronic device of paragraph 35, wherein the connector segment is located at least partially below the housing, but is not attached to the housing.

[0117] Paragraph 42. A method of applying an electronic device having a housing, a first wing and a second wing to a mammal for long-term adhesion, the method comprising:

- removing a first adhesive cover from the first wing of the electronic device to expose an electrode and an adhesive coated on a bottom surface of the first wing;
- placing the exposed electrode into contact with the mammal by adhering the adhesive coated bottom of the first wing to the mammal;
- removing a second adhesive cover from the second wing of the electronic device to expose an adhesive coated on a bottom surface of the second wing and another exposed electrode; and
- placing the another exposed electrode into contact with the mammal by adhering the adhesive coated bottom of the second wing to the mammal;
- wherein after performing the removing and the placing steps the housing is unattached to the mammal, but is held in position on the mammal using the adhesive coated bottoms of the first and the second wings.

[0118] Paragraph 43. The method of paragraph 42,

wherein the electronic device comprises a first flap connected to the first wing and a second flap connected to the second wing, the first and second flaps each extending below the housing,

5 wherein the step of removing a first adhesive cover from the first wing further comprises exposing an adhesive coated on a bottom surface of the first flap, and wherein the step of removing a second adhesive cover from the second wing further comprises exposing an adhesive coated on a bottom surface of the second flap.

10 [0119] Paragraph 44. The method of paragraph 43, wherein after performing the removing and the placing steps the housing is held in position on the mammal using only the adhesive coated bottoms of the first wing, the second wing, the first flap and the second flap.

15 [0120] Paragraph 45. A method of applying an electronic device having a housing, a first wing and a second wing to a mammal for long-term adhesion, the method comprising:

- removing a first adhesive cover from the first wing of the electronic device to expose an electrode and an adhesive coated on a bottom surface of the first wing;
- 25 removing a second adhesive cover from the second wing of the electronic device to expose an adhesive coated on a bottom surface of the second wing and another exposed electrode; and
- placing the exposed electrodes into contact with the mammal by adhering the adhesive coated on the bottom of the first and the second wings to the mammal; wherein after performing the removing and the placing steps the housing is unattached to the mammal, but is held in position on the mammal using the adhesive coated bottoms of the first and the second wings.

[0121] Paragraph 46. An electronic device for long-term adhesion to a mammal, the device comprising:

- 40 a patch, the patch comprising a housing having an electronic component contained therein;
- an electrode positioned on a bottom surface of the patch, the electrode electrically connected to the electronic component;
- 45 a first adhesive strip extending around the perimeter of the patch; and
- a second adhesive strip extending around the perimeter of the first adhesive strip.

[0122] Paragraph 47. The electronic device of paragraph 46, further comprising a first adhesive cover over the first adhesive strip and a second adhesive cover over the second adhesive strip, the first and second adhesive covers configured to be separably removed from the first and second adhesive strips.

[0123] Paragraph 48. The electronic device of paragraph 47, wherein the first adhesive strip extends be-

tween the first and second adhesive covers.

[0124] Paragraph 49. The electronic device of paragraph 46, wherein the adhesive in the first and the second adhesive strips is an adhesive that can absorb fluids.

[0125] Paragraph 50. The electronic device of paragraph 49, wherein the adhesive that can absorb fluids is a hydrocolloid adhesive.

[0126] Paragraph 51. The electronic device of paragraph 46, wherein the adhesive in the first and the second adhesive is a pressure-sensitive adhesive.

[0127] Paragraph 52. The electronic device of paragraph 51 wherein the pressure-sensitive adhesive is selected from the group consisting of: a polyacrylate, a polyisobutylene, and a polysiloxane.

[0128] Paragraph 53. The electronic device of paragraph 46, wherein the second adhesive strip partially overlaps the first adhesive strip.

[0129] Paragraph 54. The electronic device of paragraph 46, wherein the second adhesive strip is attached to a shell, the shell overlapping the first adhesive strip.

[0130] Paragraph 55. The electronic device of paragraph 46, wherein the electronic component is a battery.

[0131] Paragraph 56. The electronic device of paragraph 46, wherein the electronic component is a printed circuit board.

[0132] Paragraph 57. A method of applying an electronic device to a mammal for long-term adhesion, wherein the electronic device includes a patch having an electronic component contained therein, an electrode positioned on a bottom surface of the patch and electrically connected to the electronic component, a first adhesive strip extending around the perimeter of the patch, and a second adhesive strip extending around the perimeter of the first adhesive strip, the method comprising:

- removing an adhesive cover from the second adhesive strip of the electronic device;
- applying pressure to the second adhesive strip to adhere the second adhesive strip to the mammal such that the electrode is in contact with the mammal;
- after a period of time, removing an adhesive cover from the first adhesive strip of the electronic device;
- applying pressure to the first adhesive strip to adhere the first adhesive strip to the mammal such that the electrode remains in contact with the mammal.

[0133] Paragraph 58. A method of applying an electronic device to a mammal for long-term adhesion, wherein the electronic device includes a patch having an electronic component contained therein, an electrode positioned on a bottom surface of the patch and electrically connected to the electronic component, and a first adhesive strip extending around the perimeter of the patch, the method comprising:

- applying pressure to a first adhesive strip to adhere the first adhesive strip to the mammal such that the electrode is in contact with the mammal;

after a period of time, placing a second adhesive strip around the perimeter of the first adhesive strip; and

applying pressure to the second adhesive strip to adhere the second adhesive strip to the mammal such that the electrode remains in contact with the mammal.

[0134] Paragraph 59. An electronic device for long-term adhesion to a mammal, the device comprising:

- a patch, the patch comprising a housing having an electronic component contained therein;
- an electrode positioned on a bottom surface of the patch, the electrode electrically connected to the electronic component; and
- a porous foam pad configured to be positioned between the electronic component and the mammal.

[0135] Paragraph 60. The electronic device of paragraph 59, wherein the electronic component is a battery.

[0136] Paragraph 61. The electronic device of paragraph 59, wherein the electronic component is a printed circuit board.

[0137] Paragraph 62. The electronic device of paragraph 59, wherein the porous foam pad comprises a biocompatible foam material.

[0138] Paragraph 63. The electronic device of paragraph 59, wherein the porous foam pad can absorb fluids.

[0139] Paragraph 64. The electronic device of paragraph 59, wherein the porous foam pad is attached to the housing.

[0140] Paragraph 65. The electronic device of paragraph 59, wherein the porous foam pad is configured to be attached to the mammal.

[0141] Paragraph 66. The electronic device of paragraph 59, wherein the porous foam pad can absorb fluids.

**40 Claims**

1. An electronic device (100) for long-term adhesion to a mammal, the device comprising:

- a flexible first wing (104) and a flexible second wing (106) extending laterally from a housing without overlapping, wherein each wing includes a hinge portion (194, 196) adjacent the housing;
- a first electrode (124) positioned on the bottom surface of the first wing and a second electrode (126) positioned on the bottom surface of the second wing, the electrodes electronically connected to a rigid physiologic data collection circuit (108);
- an adhesive layer (164, 166) on the bottom surface of each wing, the adhesive layer providing adhesion to the surface of the mammal; and

a floating section (102, 455) forming a water-tight enclosure and comprising the rigid physiologic data collection circuit (108), the floating section configured to float above the surface of the mammal in response to movement of the mammal;  
 wherein the rigid physiologic data collection unit (108) extends along only a portion of the distance between the electrodes (124, 126).

- 2. The electronic device (100) of claim 1, wherein each hinge portion (194, 196) has a thickness less than a thickness of an adjacent portion of the first wing (104) or the second wing (106).
- 3. The electronic device (100) of any one of the previous claims, wherein each hinge portion (194, 196) is configured to bend at a first intersection between the hinge portion and the adhesive layer (164, 166) and at a second intersection between the hinge portion and the housing.
- 4. The electronic device (100) of any one of the previous claims, wherein the first wing (104) and the second wing (106) are made from different materials than the housing.
- 5. The electronic device (100) of any one of the previous claims, wherein the adhesive layer (164, 166) comprises adhesive that can absorb fluids, optionally wherein the adhesive comprises a hydrocolloid adhesive.
- 6. The electronic device (100) of any one of the previous claims, wherein the adhesive layer (164, 166) comprises a pressure-sensitive adhesive, optionally wherein the pressure sensitive adhesive is selected from the group consisting of a polyacrylate, a polyisobutylene, and a polysiloxane.
- 7. The electronic device (100) of any one of the previous claims, wherein the floating section (102, 455) has a height that extends no more than 4 cm off of the skin of the mammal when floating above the skin.
- 8. The electronic device (100) of any one of the previous claims, wherein the first wing (104) and the second wing (106) are each more flexible than the floating section (102, 455).
- 9. The electronic device (100) of any one of the previous claims, further comprising a diffusion barrier between the adhesive layer and each of the first and second wings (104, 106), optionally wherein the diffusion barrier comprises polyester.
- 10. The electronic device (100) of any one of the previous claims, wherein the rigid physiologic data col-

5  
10  
15  
20  
25  
30  
35  
40  
45  
50  
55

lection circuit (108) is configured to collect cardiac rhythm data from the mammal.

- 11. The electronic device (100) of any one of the previous claim, wherein the housing comprises a flexible body extending between the first wing (104) and the rigid physiologic data collection circuit (108) and between the second wing (106) and the rigid physiologic data collection circuit (108).
- 12. The electronic device (100) of any one of the previous claims, further comprising a first electrical connection (120) between the first electrode (124) and the physiological data collection circuit (108) and a second electrical connection (120) between the second electrode (126) and the physiological data collection circuit (108), the electrical connections configured to remain mechanically unstressed during movement of the mammal.
- 13. The electronic device (100) of claim 11, wherein a first electrical connection (120) electrically connects the first electrode (124) to the rigid physiologic data collection circuit (108) and a second electrical connection (120) electrically connects the second electrode (126) to the physiologic data collection circuit (108), the first and second electrical connections being enclosed within the flexible body extending between the first wing (104) and the rigid physiologic data collection circuit (108) and between the second wing (106) and the rigid physiologic data collection circuit (108).
- 14. The electronic device (100) of claim 11, where the flexible body is continuous between the first wing (104) and the second wing (106).
- 15. The electronic device (100) of claim 14, wherein the flexible body extends continuously from the first wing (104) to the second wing (106) below the rigid physiologic data collection circuit (108).

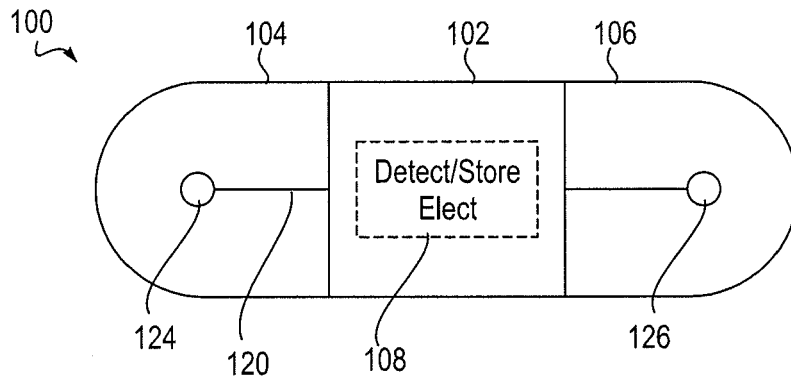

FIG. 1

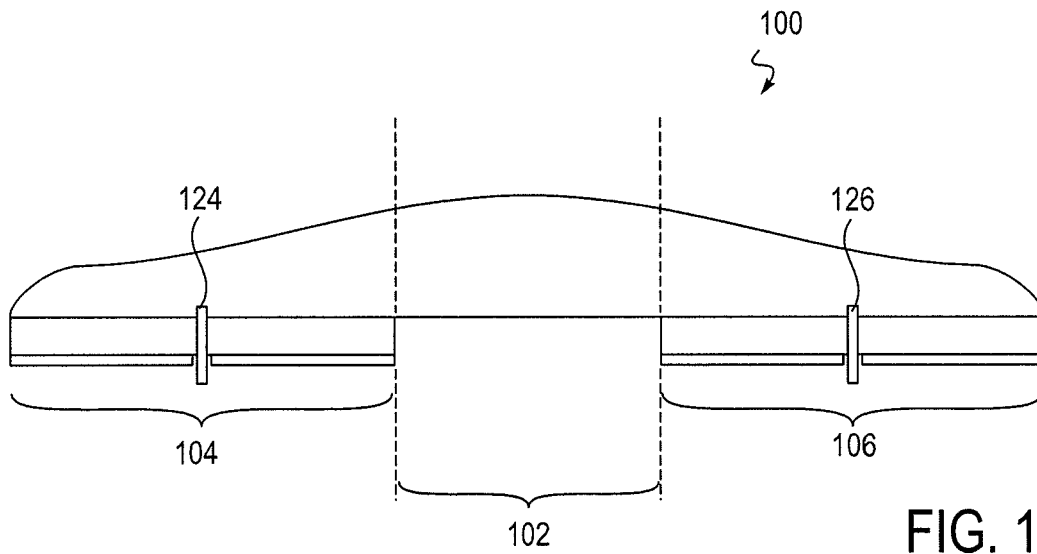

FIG. 1A

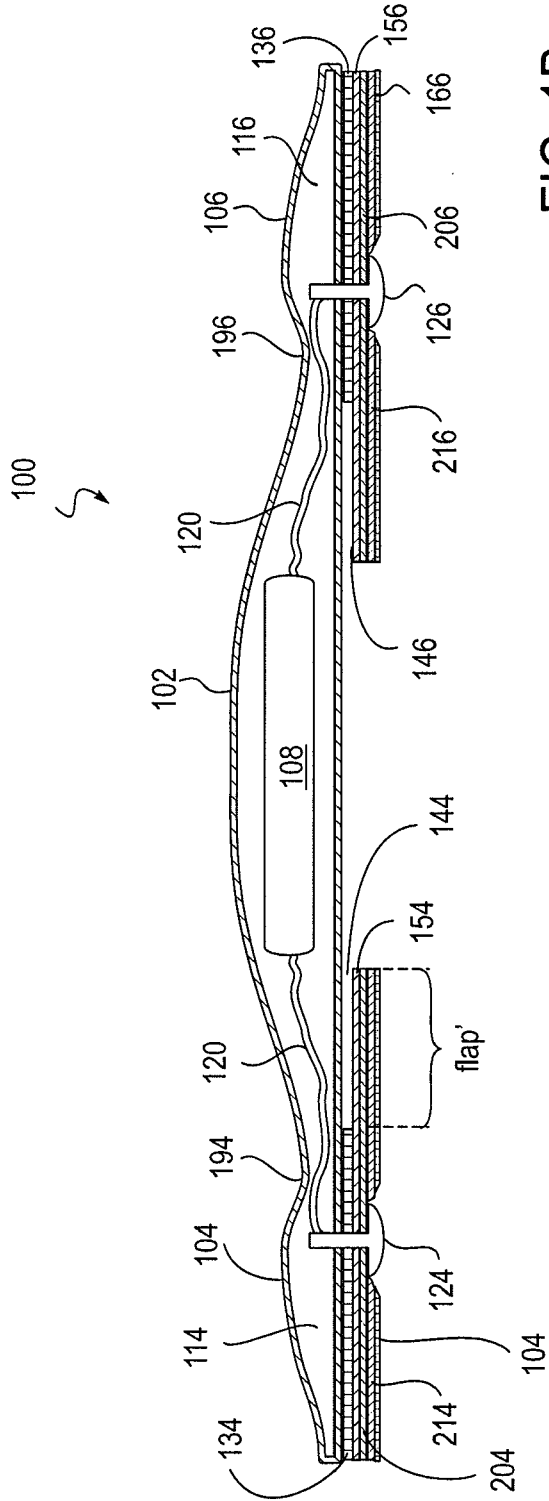

FIG. 1B

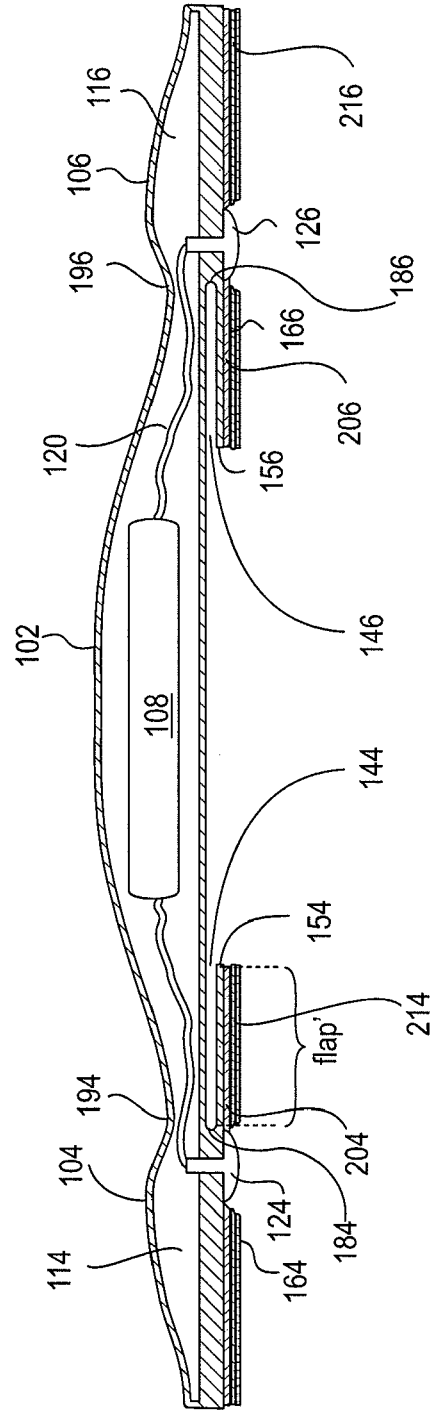

FIG. 1C

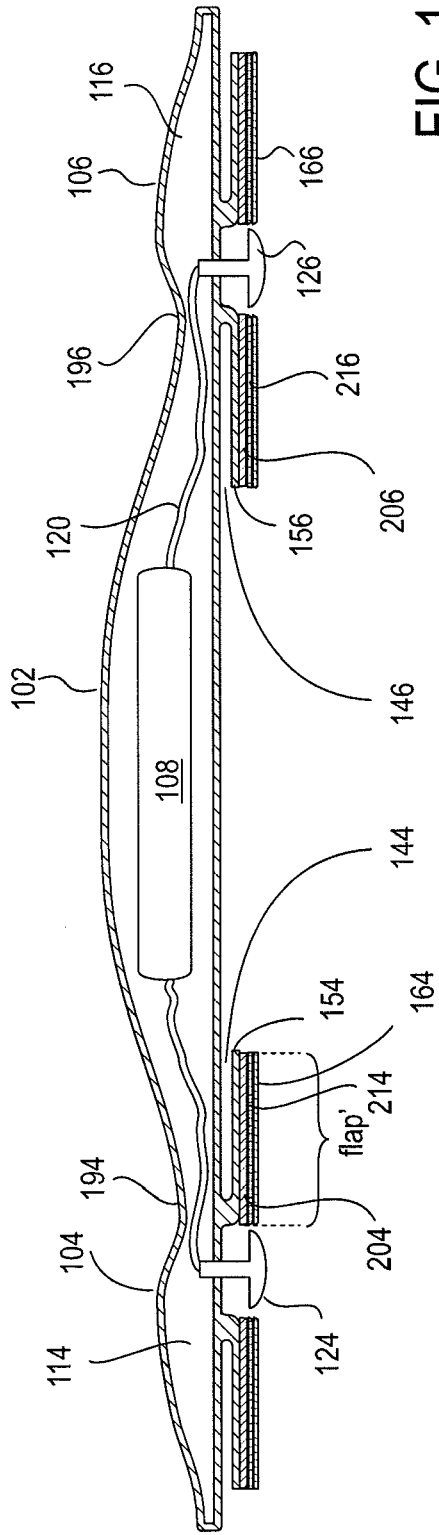

FIG. 1D

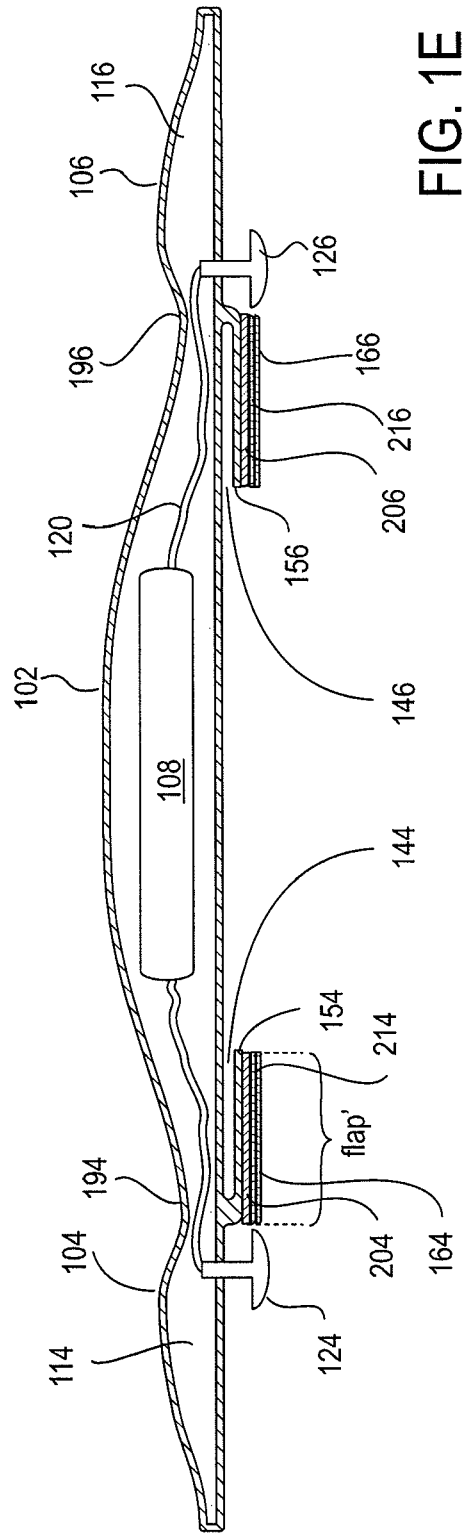

FIG. 1E

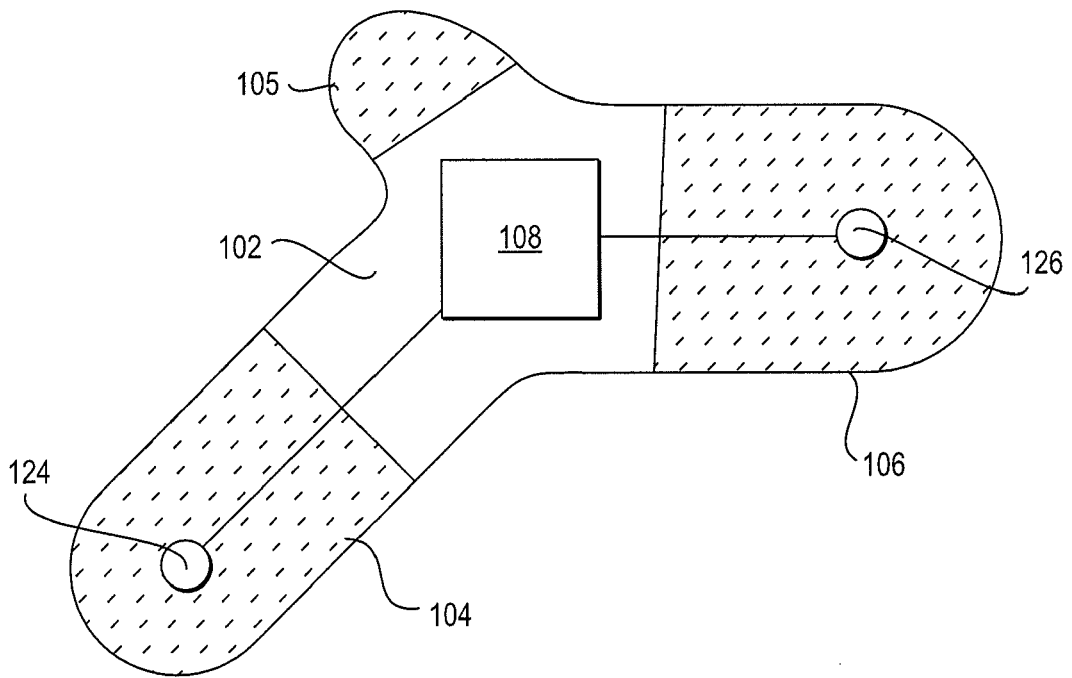

FIG. 1F

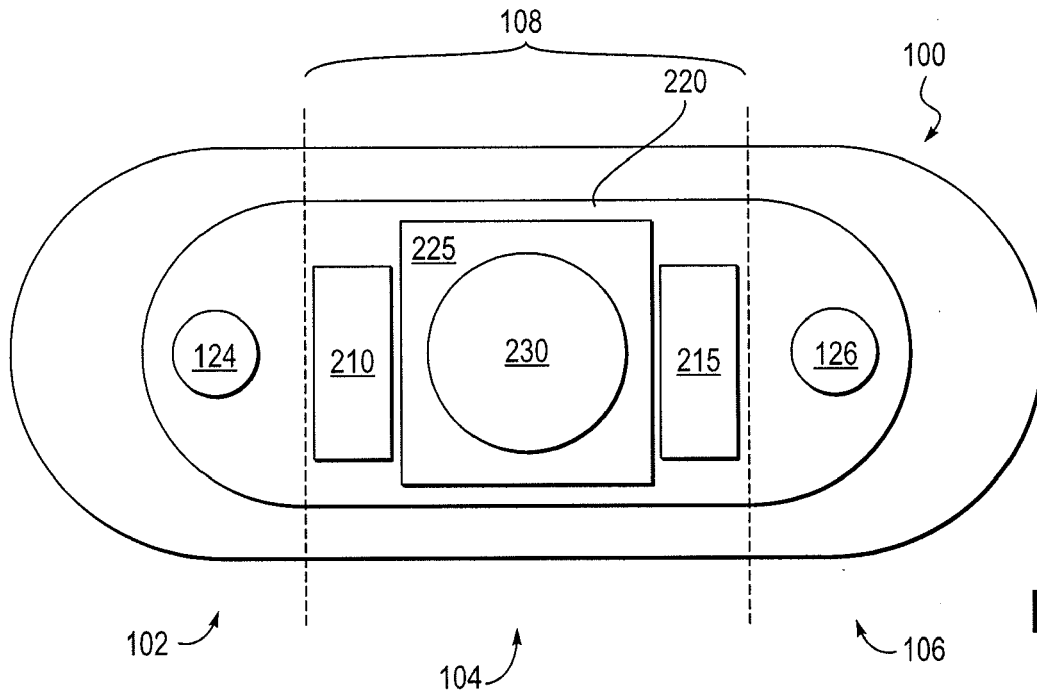

FIG. 2A

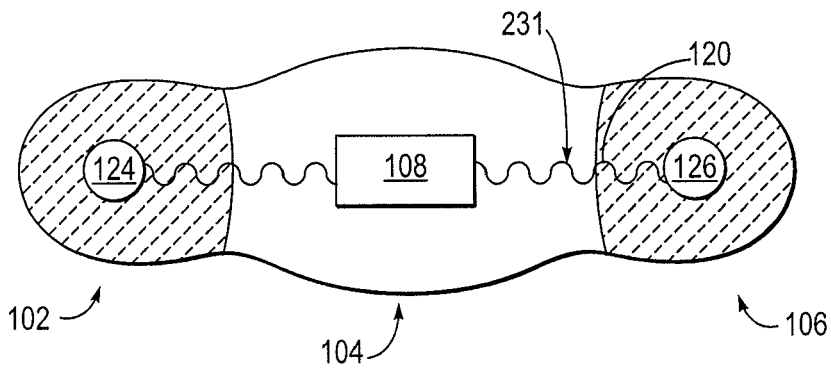

FIG. 2B

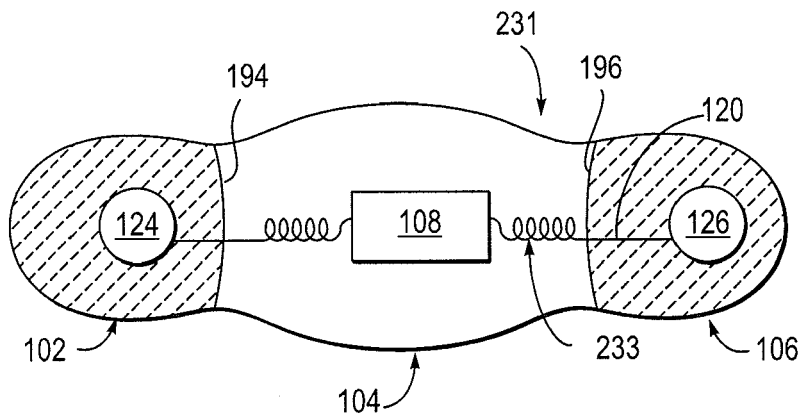

FIG. 2C

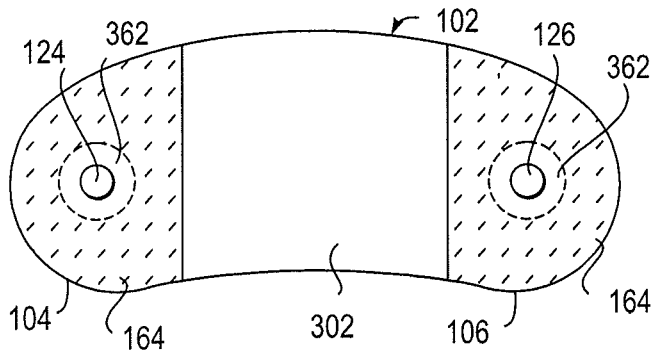

FIG. 3

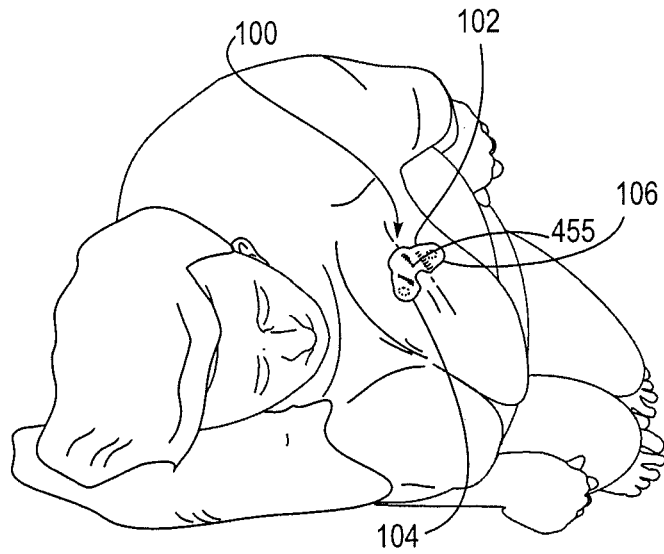

FIG. 4A

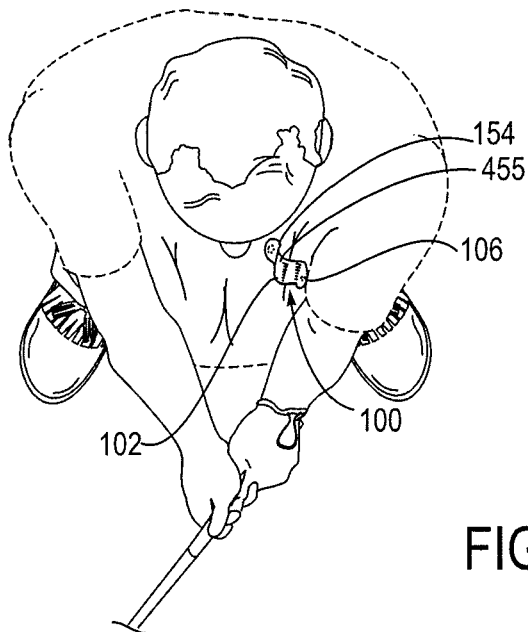

FIG. 4B

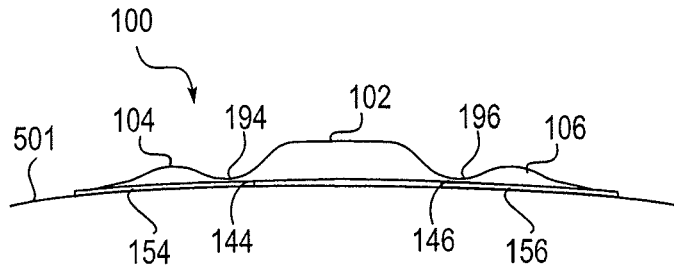

FIG. 5A

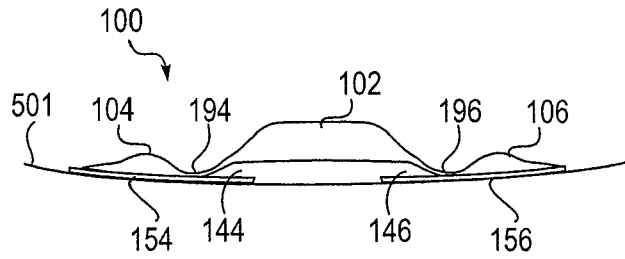

FIG. 5B

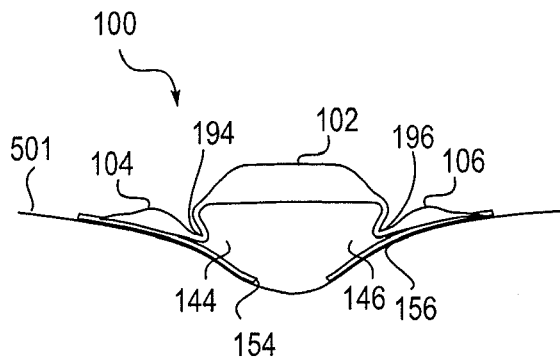

FIG. 5C

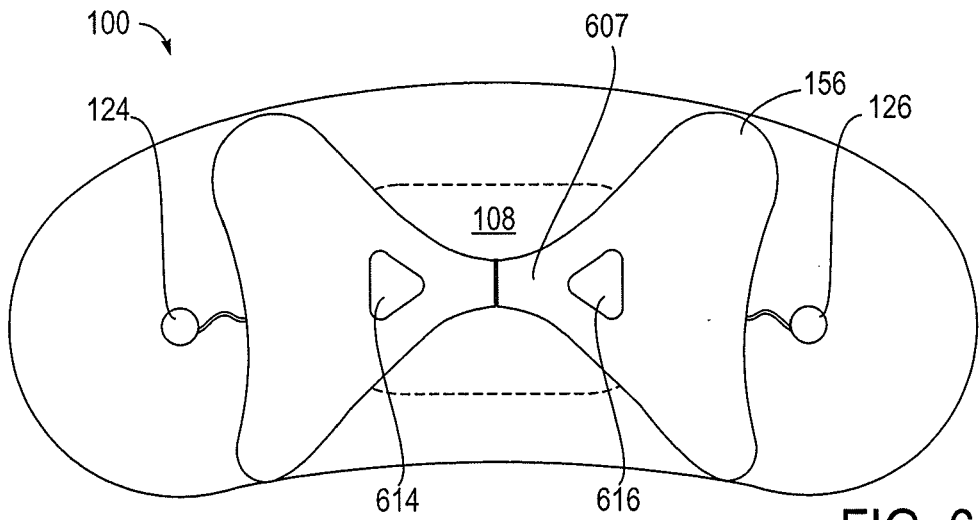

FIG. 6A

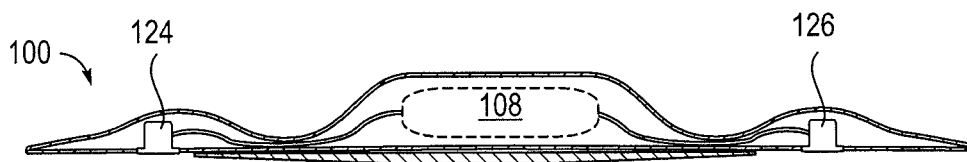

FIG. 6B

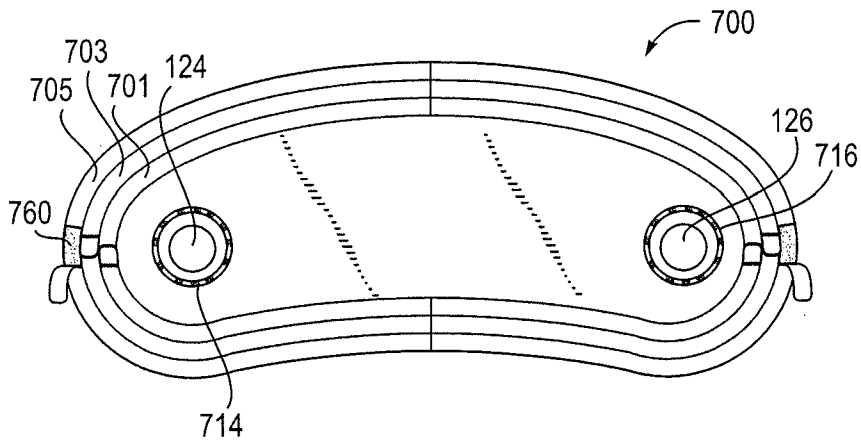

FIG. 7A

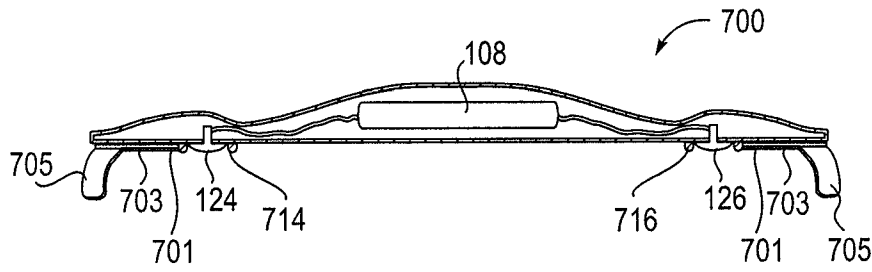

FIG. 7B

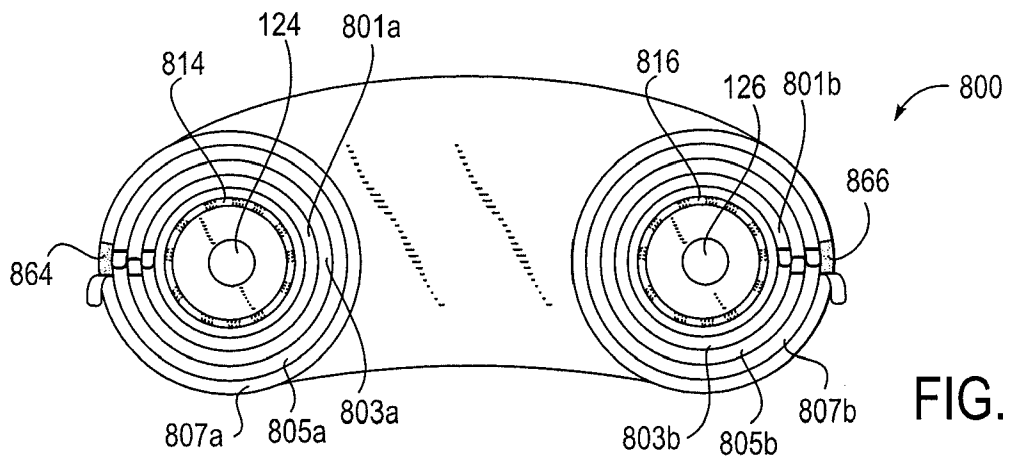

FIG. 8A

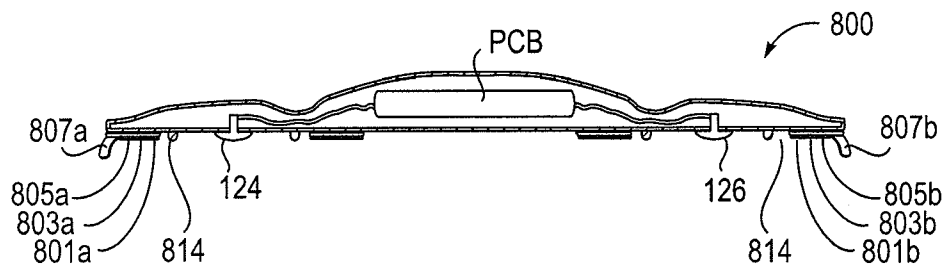
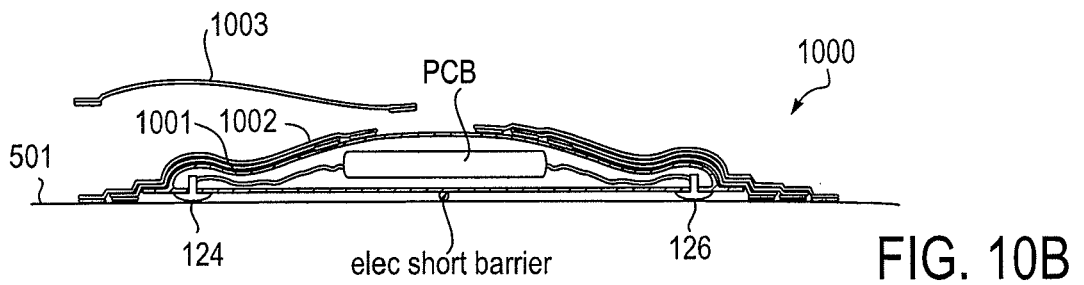
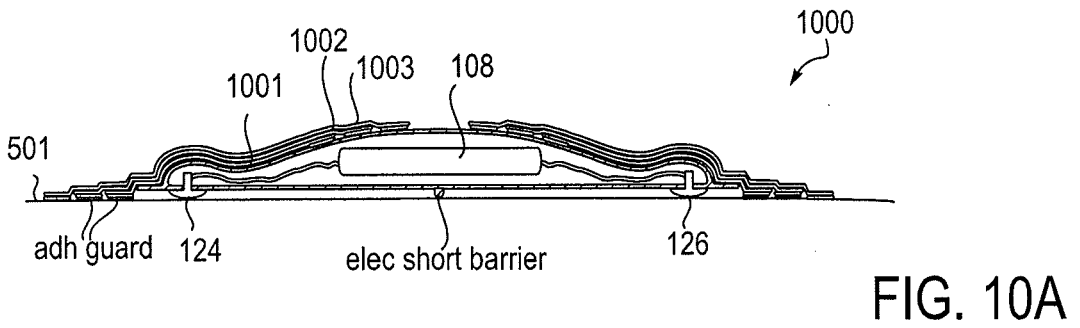
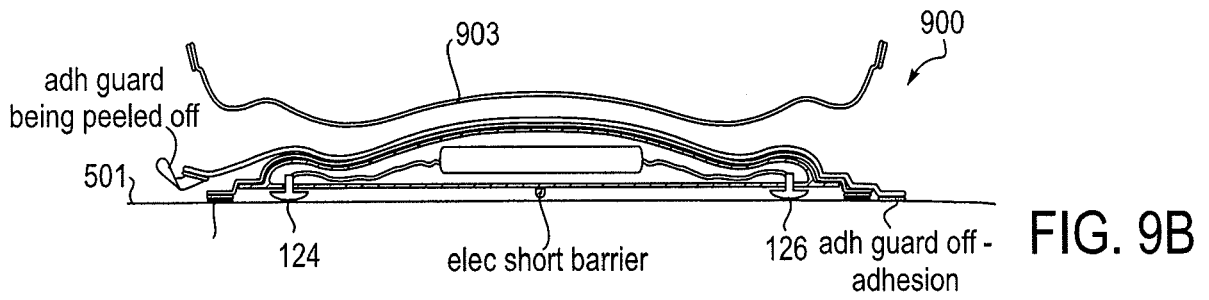
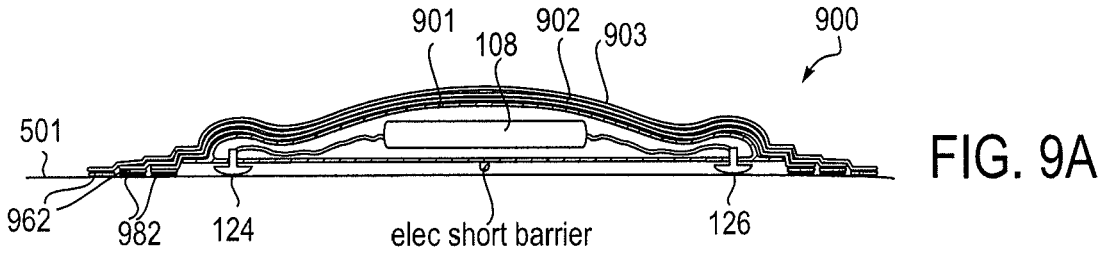

FIG. 8B



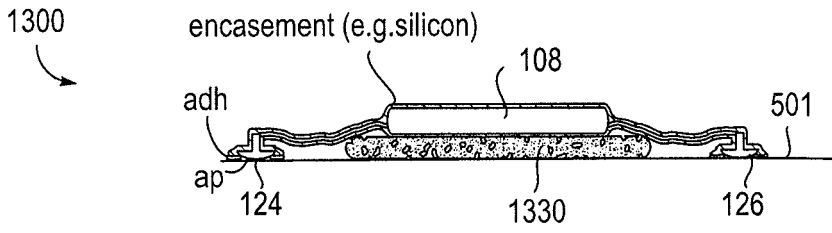

FIG. 11

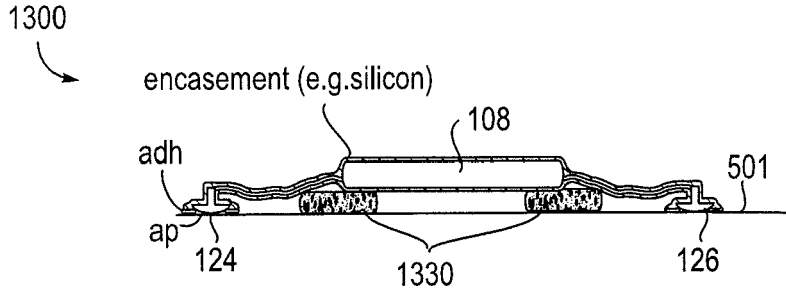

FIG. 12

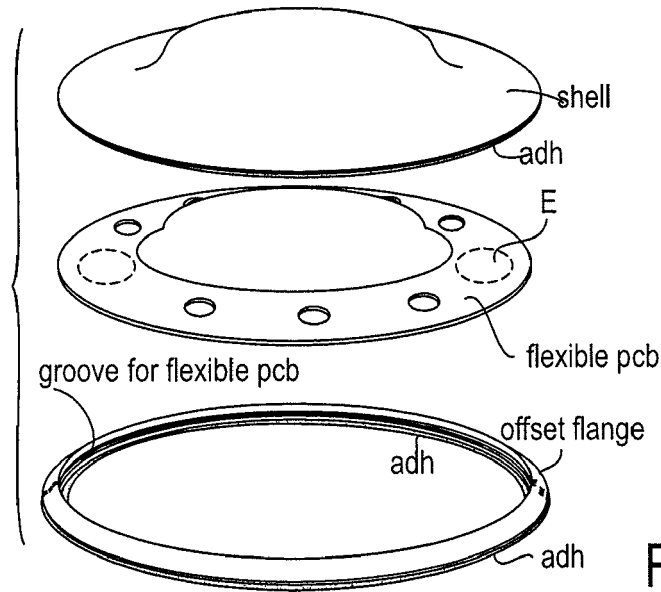

FIG. 13A

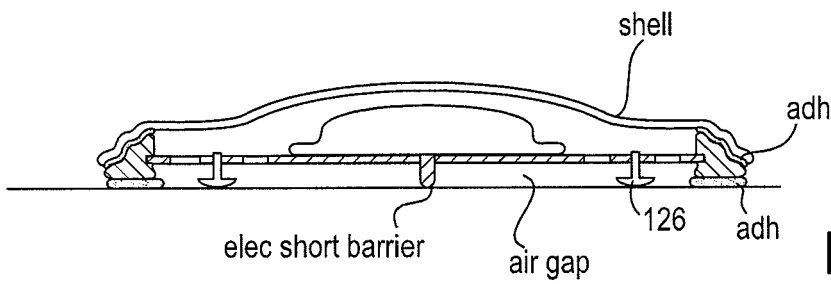

FIG. 13B



EUROPEAN SEARCH REPORT

Application Number  
EP 18 17 5409

5

10

15

20

25

30

35

40

45

50

55

| DOCUMENTS CONSIDERED TO BE RELEVANT                                                                                                                                                                                                                    |                                                                                                                                                                                                                                                      |                                                                                                                                                                                                                                                                                       |                                                            |
|--------------------------------------------------------------------------------------------------------------------------------------------------------------------------------------------------------------------------------------------------------|------------------------------------------------------------------------------------------------------------------------------------------------------------------------------------------------------------------------------------------------------|---------------------------------------------------------------------------------------------------------------------------------------------------------------------------------------------------------------------------------------------------------------------------------------|------------------------------------------------------------|
| Category                                                                                                                                                                                                                                               | Citation of document with indication, where appropriate, of relevant passages                                                                                                                                                                        | Relevant to claim                                                                                                                                                                                                                                                                     | CLASSIFICATION OF THE APPLICATION (IPC)                    |
| X<br>A                                                                                                                                                                                                                                                 | WO 2007/092543 A2 (UNIV LELAND STANFORD JUNIOR [US]; KUMAR UDAY N [US]; KNIGHT JOSEPH ALL) 16 August 2007 (2007-08-16)<br>* figures 3A,B, 6A-C, 7A, 8C10 *<br>* paragraphs [0025], [0057], [0058], [0065], [0099], [0101], [0110], [0112] *<br>----- | 1-3,5-7, 9-15<br><br>4,8                                                                                                                                                                                                                                                              | INV.<br>A61B5/0424<br>A61B5/0408<br>A61B5/00<br>A61B5/0478 |
| X<br>A                                                                                                                                                                                                                                                 | GB 2 348 707 A (HEALTHCARE TECHNOLOGY LTD [GB]) 11 October 2000 (2000-10-11)<br>* figures 1, 2, 5 *<br>* claim 1 *<br>* column 3, lines 9-37 *<br>* column 4, lines 11-17 *<br>-----                                                                 | 1,4-10, 12-15<br>2,3,11                                                                                                                                                                                                                                                               |                                                            |
|                                                                                                                                                                                                                                                        |                                                                                                                                                                                                                                                      |                                                                                                                                                                                                                                                                                       | TECHNICAL FIELDS SEARCHED (IPC)                            |
|                                                                                                                                                                                                                                                        |                                                                                                                                                                                                                                                      |                                                                                                                                                                                                                                                                                       | A61B                                                       |
| The present search report has been drawn up for all claims                                                                                                                                                                                             |                                                                                                                                                                                                                                                      |                                                                                                                                                                                                                                                                                       |                                                            |
| Place of search<br><b>The Hague</b>                                                                                                                                                                                                                    |                                                                                                                                                                                                                                                      | Date of completion of the search<br><b>16 July 2018</b>                                                                                                                                                                                                                               | Examiner<br><b>Almeida, Mariana</b>                        |
| CATEGORY OF CITED DOCUMENTS<br>X : particularly relevant if taken alone<br>Y : particularly relevant if combined with another document of the same category<br>A : technological background<br>O : non-written disclosure<br>P : intermediate document |                                                                                                                                                                                                                                                      | T : theory or principle underlying the invention<br>E : earlier patent document, but published on, or after the filing date<br>D : document cited in the application<br>L : document cited for other reasons<br>.....<br>& : member of the same patent family, corresponding document |                                                            |

EPO FORM 1503 03/02 (P04C01)

ANNEX TO THE EUROPEAN SEARCH REPORT  
ON EUROPEAN PATENT APPLICATION NO.

EP 18 17 5409

5 This annex lists the patent family members relating to the patent documents cited in the above-mentioned European search report.  
The members are as contained in the European Patent Office EDP file on  
The European Patent Office is in no way liable for these particulars which are merely given for the purpose of information.

16-07-2018

| Patent document cited in search report | Publication date | Patent family member(s) | Publication date |
|----------------------------------------|------------------|-------------------------|------------------|
| WO 2007092543 A2                       | 16-08-2007       | CA 2651203 A1           | 16-08-2007       |
|                                        |                  | EP 1981402 A2           | 22-10-2008       |
|                                        |                  | JP 5203973 B2           | 05-06-2013       |
|                                        |                  | JP 2009525816 A         | 16-07-2009       |
|                                        |                  | US 2007225611 A1        | 27-09-2007       |
|                                        |                  | US 2007249946 A1        | 25-10-2007       |
|                                        |                  | US 2007255153 A1        | 01-11-2007       |
|                                        |                  | US 2012215123 A1        | 23-08-2012       |
|                                        |                  | US 2013226018 A1        | 29-08-2013       |
|                                        |                  | WO 2007092543 A2        | 16-08-2007       |
| -----                                  |                  |                         |                  |
| GB 2348707 A                           | 11-10-2000       | GB 2348707 A            | 11-10-2000       |
|                                        |                  | US 6580942 B1           | 17-06-2003       |
| -----                                  |                  |                         |                  |

EPO FORM P0459

For more details about this annex : see Official Journal of the European Patent Office, No. 12/82

**REFERENCES CITED IN THE DESCRIPTION**

*This list of references cited by the applicant is for the reader's convenience only. It does not form part of the European patent document. Even though great care has been taken in compiling the references, errors or omissions cannot be excluded and the EPO disclaims all liability in this regard.*

**Patent documents cited in the description**

- US 61334081 A [0001]
- US 70342807 A [0037]

|               |                                                                                                                                      |         |            |
|---------------|--------------------------------------------------------------------------------------------------------------------------------------|---------|------------|
| 专利名称(译)       | 设备特征和设计元素，用于长期粘合                                                                                                                     |         |            |
| 公开(公告)号       | <a href="#">EP3387991A1</a>                                                                                                          | 公开(公告)日 | 2018-10-17 |
| 申请号           | EP2018175409                                                                                                                         | 申请日     | 2011-05-12 |
| 申请(专利权)人(译)   | IRHYTHM TECHNOLOGIES , INC.                                                                                                          |         |            |
| 当前申请(专利权)人(译) | IRHYTHM TECHNOLOGIES , INC.                                                                                                          |         |            |
| [标]发明人        | KUMAR UDAY N<br>LIVINGSTON PETER H<br>DAY MARK J<br>PARK SHENA H<br>WILLIS WILLIAM F<br>RIGHTER WILLIAM H                            |         |            |
| 发明人           | KUMAR,, UDAY, N.<br>LIVINGSTON,, PETER, H.<br>DAY,, MARK, J.<br>PARK,, SHENA, H.<br>WILLIS,, WILLIAM, F.<br>RIGHTER,, WILLIAM, H.    |         |            |
| IPC分类号        | A61B5/0424 A61B5/0408 A61B5/00 A61B5/0478 B31B50/62                                                                                  |         |            |
| CPC分类号        | A61B5/0408 A61B5/0478 A61B5/6833 A61B5/68335 A61B2560/0406 A61B2560/0468 Y10T156/10<br>A61B5/04085 A61B5/04087 A61B5/0488 A61B5/6832 |         |            |
| 代理机构(译)       | POTTER CLARKSON LLP                                                                                                                  |         |            |
| 优先权           | 61/334081 2010-05-12 US<br>PCT/US2011/036335 2011-05-12 WO                                                                           |         |            |
| 外部链接          | <a href="#">Espacenet</a>                                                                                                            |         |            |

摘要(译)

提供一种用于长期粘附到哺乳动物的电子装置，该装置包括：柔性第一翼和从壳体侧向延伸而不重叠的柔性第二翼，其中每个翼包括邻近壳体的铰链部分；位于第一翼的底表面上的第一电极和位于第二翼的底表面上的第二电极，电极电连接到刚性生理数据收集电路；在每个翼的底表面上的粘合剂层，粘合剂层提供对哺乳动物表面的粘附；形成防水外壳并包括刚性生理数据收集回路的浮动部分，该浮动部分构造成响应于哺乳动物的运动而漂浮在哺乳动物的表面上方；其中刚性生理数据收集单元仅沿电极之间的距离的一部分延伸。

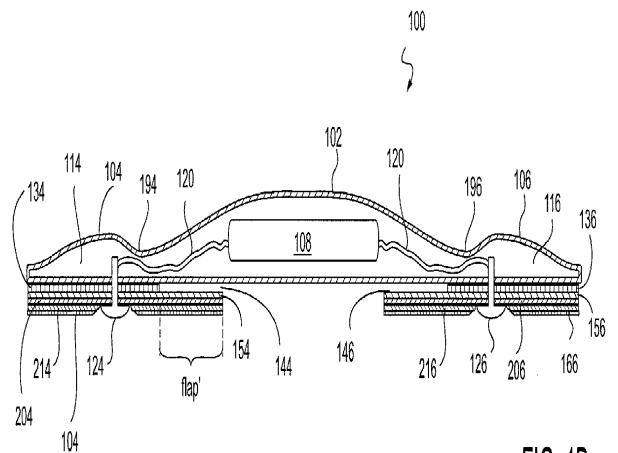

FIG. 1B