

(19)



(11)

EP 2 568 878 B1

(12)

EUROPEAN PATENT SPECIFICATION

(45) Date of publication and mention of the grant of the patent:
25.07.2018 Bulletin 2018/30

(51) Int Cl.:
A61B 5/0478 (2006.01) A61B 5/00 (2006.01)
A61B 5/0408 (2006.01)

(21) Application number: **11781310.5**

(86) International application number:
PCT/US2011/036335

(22) Date of filing: **12.05.2011**

(87) International publication number:
WO 2011/143490 (17.11.2011 Gazette 2011/46)

(54) **DEVICE FEATURES AND DESIGN ELEMENTS FOR LONG-TERM ADHESION**

GERÄTEFUNKTIONEN UND DESIGN-ELEMENTE FÜR EINE LANGZEITHAFTUNG

CARACTÉRISTIQUES DE DISPOSITIF ET ÉLÉMENTS DE CONSTRUCTION POUR ADHÉRENCE À LONG TERME

(84) Designated Contracting States:
AL AT BE BG CH CY CZ DE DK EE ES FI FR GB GR HR HU IE IS IT LI LT LU LV MC MK MT NL NO PL PT RO RS SE SI SK SM TR

- **DAY, Mark, J.**
San Francisco, CA 94103 (US)
- **PARK, Shena, H.**
San Francisco, CA 94103 (US)
- **WILLIS, William, F.**
San Francisco, CA 94103 (US)
- **RIGHTER, William, H.**
San Francisco, CA 94103 (US)

(30) Priority: **12.05.2010 US 334081 P**

(43) Date of publication of application:
20.03.2013 Bulletin 2013/12

(74) Representative: **Potter Clarkson LLP**
The Belgrave Centre
Talbot Street
Nottingham NG1 5GG (GB)

(60) Divisional application:
16203847.5 / 3 165 161
18175409.4

(73) Proprietor: **Irhythm Technologies, Inc.**
San Francisco, CA 94103 (US)

(56) References cited:
WO-A1-2007/063436 WO-A2-2006/094513
WO-A2-2007/092543 WO-A2-2008/057884
WO-A2-2009/055397 GB-A- 2 348 707
US-A1- 2003 149 349 US-A1- 2006 224 072
US-A1- 2007 249 946 US-A1- 2008 091 089
US-A1- 2008 108 890 US-B1- 6 580 942

(72) Inventors:
 • **KUMAR, Uday, N.**
San Francisco, CA 94103 (US)
 • **LIVINGSTON, Peter, H.**
San Francisco, CA 94103 (US)

Note: Within nine months of the publication of the mention of the grant of the European patent in the European Patent Bulletin, any person may give notice to the European Patent Office of opposition to that patent, in accordance with the Implementing Regulations. Notice of opposition shall not be deemed to have been filed until the opposition fee has been paid. (Art. 99(1) European Patent Convention).

EP 2 568 878 B1

Description**FIELD OF THE INVENTION**

[0001] This application relates to devices worn on a body for monitoring, recording, reporting and/or treating the person wearing the device. Improvements in the device design elements and functionality are disclosed for maintaining the device in contact with and operational for extended periods of time, typically longer than 24 hours.

BACKGROUND OF THE INVENTION

[0002] The ability to adhere a medical device to a human body for a long-period of time is dependent on a variety of factors. In addition to the type and nature of the adhesive chosen, another factor is the mechanical design of the device. By design, this refers to, but is not limited to, the device shape, size, weight, flexibility, and rigidity. These design elements are influenced by a number of additional factors, including, but not limited to, where on the body the device will attach and the duration of the attachment, moisture conditions in that area, movement conditions in that area, stretching and contraction in that area, interactions with external factors in that area such as clothing, and purposeful and/or inadvertent interaction between the person wearing the device and the device.

[0003] As many devices are typically used on the body for less than 24 hours, devices have not been designed that can withstand longer-term adhesion. Hence, there is a need to implement device features and design elements that have the ability to enhance the likelihood of adhesion of a device to a human body for 24 hours or more, while accommodating the functionality, shape, size, weight, flexibility, and rigidity of a given device.

SUMMARY OF THE INVENTION

[0004] According to the present invention there is provided an electronic device in accordance with Claim 1.

[0005] The electronic component in any of the devices described herein may include a processor having a memory with computer readable instructions to record signals from the first and second electrodes while the electronic device is attached to the mammal. The processor may be configured to only convert signals from the electrodes to digital signals, filter those signals and then store the signals in memory.

[0006] The device includes a flap connected to each of the wings. The flaps extend below the housing. Additionally or alternatively, the adhesive layer is coated on a bottom surface of the flaps.

[0007] In another aspect, the device includes a connector segment. In one aspect, the connector segment configured to connect the flaps together. In other aspects, the connector segment is located at least partially below

the housing. Still further, the connector segment is not attached to the housing.

[0008] In one alternative, the adhesive layer is coated on a bottom surface of the flap.

5 [0009] In still another aspect, the adhesive for adhesion to a surface of the mammal is an adhesive that can absorb fluids. In another aspect, the adhesive that can absorb fluids is a hydrocolloid adhesive. In another aspect, the adhesive for adhesion to a surface of the mam-
10 mal is a pressure-sensitive adhesive. The pressure sensitive adhesive is selected from the group consisting of: a polyacrylate, a polyisobutylene, and a polysiloxane. In one alternative, the device includes a diffusion barrier between the adhesive layer and each of the wings. The device may also include an additional adhesive layer and material layer between the wing and the adhesive layer for adhesion to the mammal. The material layer is con-
15 figured to prevent diffusion of adhesive components from the adhesive layer to the wing. The diffusion barrier may be made from polyester or other suitable synthetic material.

[0010] In one aspect of the device, all or substantially all of the electronic components are within the housing. In another aspect, the wing is free from electronic components. In one aspect, the wing is more flexible than the housing. In one alternative, the wings and the housing are made from the same material. In another aspect, the wings and the housing are made from different materials. In another, the wings are made from a fabric. In still another aspect, the material used to make the wings includes a synthetic fiber. In another alternative, the wing and the flap are composed of the same material.

[0011] In another alternative, the device includes a hinge portion between the housing and the wing. The hinge portion is configured to allow the device to bend between the housing and the wing. In one aspect, the hinge portion exists between a rigid portion of the device and a flexible portion of the device. In one alternative, the rigid portion of the device corresponds to the portion
35 of the housing including the electronics and the flexible portion of the device includes a wing.

[0012] In one aspect, the bottom surface of the wing and the bottom surface of the flap are contiguous. In another aspect, the bottom surfaces of the wings, the flap, and the connectors are contiguous. In still other aspects, the flaps and the connector are contiguous.

[0013] In another aspect, the connector has at least one hole extending it. The hole may have any of a number of shapes such as circular, oval, round, or triangular.

40 [0014] In one aspect, the housing is thicker at a center of the housing than at edges of the housing.

[0015] In another aspect of the device, the housing is unattached to the mammal when the electrodes are in contact with the mammal.

55 [0016] In another alternative aspect of a device for long-term adhesion to a mammal, the device includes a housing with a first wing extending laterally from the housing and a second wing extending laterally from the hous-

ing without overlapping the first wing. There is a first electrode positioned on a bottom surface of the first wing and a second electrode positioned on a bottom surface of the second wing. An electronic memory is positioned within the housing. The electronic memory is configured to receive and store electronic signals from the first and second electrodes while the electronic device is attached to the mammal. There is also an adhesive layer on a portion of a bottom surface of the first wing and the second wing. The adhesive is not on a bottom surface of the housing. When the device is worn on the mammal, only the adhesive layer(s) are attached to the mammal.

[0017] Also described herein, the portion of the bottom surface of the first wing and the second wing does not include the first and second electrodes. In one device aspect, the first wing, the second wing, and the housing are formed from the same material. In still another, the first wing, the second wing and the housing integrally form a monolithic structure. In other aspects, an angle formed by the first wing, the second wing, and the housing is between approximately 90° and 180°. In one variation, the angle is approximately 180°. In another variation, the angle is approximately 135°.

[0018] In still other embodiments, there is a first hinged portion between the first electrode and the processor and a second hinged portion between the second electrode and the housing.

[0019] In a further aspect, at least a portion of the body uncovered is not adhered to the mammal when signals from the electrodes are being recorded in memory.

[0020] In another aspect, the device includes a first flap connected to the first wing medial to the first electrode and a second flap connected to the second wing medial to the second electrode. Each flap may extend below the housing.

[0021] The device may also include a connector segment configured to connect the flaps together. In one aspect, the connector segment is located at least partially below the housing, but is not attached to the housing.

[0022] Also described herein, there is an electronic device that has a patch including a housing containing an electronic component. There is an electrode positioned on a bottom surface of the patch, the electrode electrically connected to the electronic component. There is a first adhesive strip extending around the perimeter of the patch and a second adhesive strip extending around the perimeter of the first adhesive strip. The first adhesive can cover over the first adhesive strip and a second adhesive cover over the second adhesive strip. The first and second adhesive covers may be configured to be separably removed from the first and second adhesive strips. In one alternative, the first adhesive strip extends between the first and second adhesive covers. In another alternative, the adhesive in the first and the second adhesive strips is an adhesive that can absorb fluids. The adhesive that can absorb fluids is a hydrocolloid adhesive. In one alternative, the adhesive in the first and the second adhesive is a pressure-sensitive adhesive. The

pressure-sensitive adhesive can be a polyacrylate, a polyisobutylene, or a polysiloxane.

[0023] The second adhesive strip can partially overlap the first adhesive strip. The second adhesive strip can be attached to a shell, the shell overlapping the first adhesive strip.

[0024] Also described herein is an alternative device for long-term adhesion to a mammal, the device includes a patch having a housing with an electronic component contained therein. There is an electrode positioned on a bottom surface of the patch. The electrode electrically connected to the electronic component. There is a porous foam pad configured to be positioned between the electronic component and the mammal. In one example, the porous foam pad comprises a biocompatible foam material. In one variation, the porous foam pad can absorb fluids. In still another example, the porous foam pad is attached to the housing. In another, the porous foam pad is configured to be attached to the mammal. In another request, the porous foam pad can absorb fluids.

[0025] Also described herein is a method of applying an electronic device, there is a step of removing a first adhesive cover from the first wing of the electronic device to expose an electrode and an adhesive coated on a bottom surface of a first wing. There is a step of placing the exposed electrode into contact with the mammal by adhering the adhesive coated bottom of the first wing to the mammal. There is also a step of removing a second adhesive cover from the second wing of the electronic device to expose an adhesive coated on a bottom surface of the second wing and another exposed electrode. There is also a step of placing the another exposed electrode into contact with the mammal by adhering the adhesive coated bottom of the second wing to the mammal. After performing the removing and the placing steps, the housing is unattached to the mammal, but is held in position on the mammal using the adhesive coated bottoms of the first and the second wings.

[0026] In one alternative method of attaching a device, the electronic device includes a first flap connected to the first wing and a second flap connected to the second wing. The first and second flaps each extend below the housing. The step of removing a first adhesive cover from the first wing may also include exposing an adhesive coated on a bottom surface of the first flap. The step of removing a second adhesive cover from the second wing may also include exposing an adhesive coated on a bottom surface of the second flap.

[0027] In another alternative method of attaching a device, after performing the removing and the placing steps, the housing is held in position on the mammal using only the adhesive coated bottoms of the first wing, the second wing, the first flap and the second flap.

[0028] In an alternative method of applying an electronic device to a mammal for long-term adhesion, the method includes removing a first adhesive cover from the first wing of the electronic device to expose an electrode and an adhesive coated on a bottom surface of the

first wing. There is also a step of removing a second adhesive cover from the second wing of the electronic device to expose an adhesive coated on a bottom surface of the second wing and another exposed electrode. There is a step of placing the exposed electrodes into contact with the mammal by adhering the adhesive coated on the bottom of the first and the second wings to the mammal. After performing the removing and the placing steps, the housing is unattached to the mammal, but is held in position on the mammal using the adhesive coated bottoms of the first and the second wings.

[0029] There is also provided a method of applying an electronic device to a mammal for long-term adhesion wherein the electronic device includes a patch. The patch includes an electronic component along with an electrode positioned on a bottom surface of the patch and electrically connected to the electronic component. There is a first adhesive strip extending around the perimeter of the patch and a second adhesive extending around the perimeter of the first adhesive strip. One example of a method of applying the device includes a step of removing an adhesive cover from the second adhesive strip of the electronic device. There is a step of applying pressure to the second adhesive strip to adhere the second adhesive strip to the mammal such that the electrode is in contact with the mammal. Then, after a period of time, removing an adhesive cover from the first adhesive strip of the electronic device. Next, there is the step of applying pressure to the first adhesive strip to adhere the first adhesive strip to the mammal such that the electrode remains in contact with the mammal.

[0030] In another alternative method of applying an electronic device to a mammal for long-term adhesion, the electronic device includes a patch, an electronic component, and an electrode positioned on a bottom surface of the patch and electrically connected to the electronic component. There is a first adhesive strip extending around the perimeter of the patch. The method includes a step of applying pressure to a first adhesive strip to adhere the first adhesive strip to the mammal such that the electrode is in contact with the mammal. After a period of time, placing a second adhesive strip around the perimeter of the first adhesive strip. Then there is the step of applying pressure to the second adhesive strip to adhere the second adhesive strip to the mammal such that the electrode remains in contact with the mammal.

[0031] Any of the above described devices may include additional aspects. A device may also include a first wire connecting the first electrode and the processor or an electronic memory and a second wire connecting the second electrode and the processor or an electronic memory. The first and second wires extend within the body and the first and second wings. In one aspect, the first and second wires extend within and are completely encapsulated within the body and the first and second wings. In one aspect, a conduit is provided within the body and the wings and the wires pass through the conduit. In one alternative, the conduit extends from the proc-

essor or electronic memory to an electrode so that the wire is completely within the conduit. In still other aspects of the devices described above, the first and second wires connecting the electrodes to the processor or electronics each include slack between the electrode and the processor. In one aspect, the slack is located in a portion of each wing that is configured to bend or flex. In another aspect, the slack is a portion of the wire within the wing and at least partially coiled about the first or the second electrode. In still other aspects, the slack is provided by a portion of the wire formed into a coil, a wave pattern, or a sinusoidal pattern along its length the connection point on the electronics to the connection point on the electrode.

[0032] In still other alternatives, the devices described above may be applied to any of a wide variety of conventional physiological data monitoring, recording and/or transmitting devices. Any of the improved adhesion design features and aspects may also be applied to conventional devices useful in the electronically controlled and/or time released delivery of pharmacological agents or blood testing, such as glucose monitors or other blood testing devices. Additional alternatives to the devices described may include the specific components of a particular application such as electronics, antenna, power supplies or charging connections, data ports or connections for down loading or off loading information from the device, adding or offloading fluids from the device, monitoring or sensing elements such as electrodes, probes or sensors or any other component or components needed in the device specific function. In still other aspects, the electronic component in any of the above devices is an electronic system configured for performing, with the electronic signals of the mammal detected by the electrodes, one or more or any combination of or the following electronic functions: monitoring, recording, analyzing, or processing using one or more algorithms electronic signals from the mammal. Still further, any of the devices described above may include appropriate components such that the device is used to detect, record, process or transmit signals or information related to signals generated by a mammal to which the device is attached including but not limited to signals generated by one or more of EKG, EEG and/or EMG.

BRIEF DESCRIPTION OF THE DRAWINGS

[0033] A better understanding of the features and advantages of the present invention will be obtained by reference to the following detailed description that sets forth illustrative embodiments, in which the principles of the invention are utilized, and the accompanying drawings of which:

FIG. 1 is a top view of a patch having two wings;
 FIG. 1A is a representative cross-section of an embodiment of the patch in FIG. 1;
 FIG. 1B is a representative cross-section of another

embodiment of the patch in FIG. 1;
 FIG. 1C is a representative cross-section of another embodiment of the patch in FIG. 1;
 FIG. 1D is a representative cross-section of another embodiment of the patch in FIG. 1;
 FIG. 1E is a representative cross-section of another embodiment of the patch in FIG. 1;
 FIG. 1F is a top view of a patch having three wings illustrating an alternative electrode-electronics-electrode orientation;
 FIG. 2A is a schematic drawing of the electronics contained within a patch;
 FIG. 2B is a schematic drawing of a patch with wiring having slack in the form of undulations between electronics and electrodes;
 FIG. 2C is a schematic drawing of a patch with wiring having slack in the form of a coil between electronics and electrodes;
 FIG. 3 is the bottom view of a patch having adhesive thereon;
 FIG. 4A shows a patch as worn by a person rolled to the side;
 FIG. 4B shows a patch as worn by a person playing golf;
 FIG. 5A shows a patch in response to a concave bend of the skin;
 FIGS. 5B and 5C show a patch in response to a convex bend of the skin;
 FIG. 6A is a bottom view of a patch having a connector between two flaps;
 FIG. 6B is a cross-section of the patch of FIG. 6A;
 FIG. 7A is a bottom view of a patch having multiple covers forming strips of adhesive;
 FIG. 7B is a cross-section of the patch of FIG. 7A;
 FIG. 8A is a bottom view of a patching having multiple covers forming strip of adhesive around each electrode;
 FIG. 8B is a cross-section of the patch of FIG. 8A;
 FIGS. 9A and 9B show a patch having multiple layers formed thereon;
 FIGS. 10A and 10B show a patching having multiple layers formed thereon, each layer having multiple patches of adhesive;
 FIG. 11 shows a patch having an open cell support;
 FIG. 12 shows a patch having an annular open cell support;
 FIG. 13A shows a patch having a protective shell thereon; and
 FIG. 13B shows a cross-section of the patch of FIG. 13A.

DETAILED DESCRIPTION

[0034] The following device features and design elements can be implemented into any device being adhered to the human body for a long-period of time, typically greater than 24 hours. As an example, the following device features and design elements can be used for

long-term adhesion of a cardiac rhythm monitoring patch ("patch") to the chest of a person.

[0035] Referring to FIGS. 1 and 1A, a patch 100 for long term adhesion includes a housing 102. The housing 102 can be formed from any flexible, durable material, such as a biocompatible polymer, for example silicone. The housing 102 can include electronic components 108 therein. As shown in FIG. 2, the electronics 108 can include a printed circuit board 220, a battery 225, and a communications port mounted on the printed circuit board 220. The printed circuit board 220 can include analog circuits 2110, digital circuits 215, and an activation or event notation button or switch 130. The electronics 108 can be used, for example, to record continuous physiological signals from a mammal wearing the patch 100. A system for continuously recording data is described further in co-owned US 2007/0249946.

[0036] A sensing patch with similar constructional features, namely flotation flaps, is also disclosed in document WO2009/055397.

[0037] As shown in FIGS. 1 and 1A, wings 104, 106 can be connected to the housing 102. The wings 104, 106 can be integral with the housing 102 and, in some embodiments, can be formed of the same material as the housing 102. The wings 102, 104 can be more flexible than the electronic components 108, which can be substantially rigid. An electrode 124, 126 extends through a bottom surface of each wing 104, 106. The electrodes can be positioned to detect an ECG of a mammal wearing the patch 100 for processing by the electronics 108. For example, the electrodes can be more than 2 cm apart, such as more than 3 cm apart, for example at least 6 cm apart. The electrodes 124, 126 can be integral with the wings 104, 106 so as to be inseparable from the wings 104, 106 when the patch is in use.

[0038] For a patch 100 that is entirely flexible and can conform, stretch, and adapt to the movement and conditions of the chest underneath the device, adhesive can be placed over the entire surface of the device that is in contact with the body, except for areas where sensors, electronics, or other elements such as electrodes are interacting with the body related to the functioning of the device may be incorporated. Thus, as shown in FIG. 3, an adhesive layer 164, 166 can coat the bottom of the patch 100 for attachment to the skin. For a patch 100 in which there may be some areas that are not completely flexible and may not be able to stretch or contract (e.g., the electronics 108), adhesive may be excluded from the portion of the patch 100 underneath these areas. In accordance with the present invention the bottom surface 302 of the housing 102, which contains the electronics, can remain free from adhesive. As shown in FIG. 1A, by not coating adhesive on a bottom surface of the housing 102, the housing 102 can float above the adhered portions, allowing for increased flexibility of the patch, as will be discussed further below. Further, as shown in FIG. 3 the bottom surface of the electrodes 124, 126 can remain free of adhesive. For example, a ring 362 without adhe-

sive can be formed around each electrode 124, 126 to separate the electrodes from the adhesive 164. The adhesive can be, for example, a pressure-sensitive adhesive, such as polyacrylate, polyisobutylene, or a polysiloxane. Alternatively, the adhesive can be a hydrocolloid which advantageously absorbs water.

[0039] The wings 104, 106 and the housing 102 can form a smooth, contiguous outer surface to the patch 100. As shown in FIG. 1A, when viewed from the top, the housing 102 and wings 104, 106 can together form an oblong substantially oval shape. Further, the housing 102 can have a thickness that is greater than the thickness of the wings 104, 106. The housing 102 and each of the wings 104, 106 when viewed in profile, can each form a dome with a height that is greater at the center than at the ends of the respective component, i.e., some or all of the components can be tapered at the ends and/or sides.

[0040] The electronics 108 extend along only a portion of the distance between the electrodes 104, 106. For example, the electronics can occupy less than 90% of the distance between the electrodes, for example less than 80%. By having the electronics 108 in a relatively limited space between the electrodes 124, 126, the flexibility of the patch 100 can be increased.

[0041] The housing 102 provides a watertight enclosure 110 for electronic components 108 of the patch 100. The electronics 108 can be unattached to the housing 102 such that the electronics 108 are free to move within the watertight enclosure 110. Allowing the relatively rigid electronics 108 to move freely within the flexible housing 102 advantageously enhances the overall flexibility of the patch 100. The wings 104, 106 can each have a watertight enclosure 114, 116 formed therein, which can be contiguous with the watertight enclosure 110 of the housing 102.

[0042] Wiring 120 or other suitable electrical connections can connect the electrodes 124, 126 with the electrical components 108 of the housing. In some embodiments, as shown in FIGS. 1B-1E, the contiguous nature of the enclosure 110 and the enclosures 112, 116 allows the wiring 120 to extend within the patch 100 from the electrodes 124, 126 to the electronic components 108. In other embodiments, one or more channels, tubes, or conduits are provided between the housing 102 and the wings 104, 106, to provide space for the wiring 120. The tube or channel may be straight or curved. In use, the wire 120 positioned in the enclosures 110, 112, 116 or in the tube or channel may move relative thereto in order to remain flexible within the housing. In one aspect, the flexible channels or tubes are formed within the device housing so that the housing, as it is being stretched, does not affect the ability of the components, such as wires, that may connect more rigid structures, to move or elongate.

[0043] As shown in FIG. 1, the wire 120 is straight with a direct line of connection between the electrodes 124, 126 and the electronics 108. FIG. 1 illustrates an embod-

iment where the length of the wires 120 connecting the electrodes 124, 126 to electronics 108 are about the same distance as the spacing between the electrode connection point on electronics 108 and the electrodes 124, 126. FIG. 1F also illustrates a straight line type connection where wire 120 length is nearly the same as the spacing between the electronics 108 and the electrodes 124, 126. However, as a patient moves, the patch 100 flexes along with patient movement. As shown in FIGS. 4B and 5C, patch flexion may be severe and is likely to occur during long term monitoring. In order to address the possible dislocation or breakage of the wire 120, the length or shape of the wire 120 may be selected to permit patch flexion to occur with little risk of wire 120 pulling from the electrode or electronics. Numerous alternatives are possible to compensate for patch flexion. Exemplary configurations include undulations or zig-zags 231 as shown in FIG. 2B, coils 233 as shown in FIG. 2C, or a configuration that partially or fully wraps around an electrode. In some embodiments, other components, such as the circuit board or electrodes, can alternatively or additionally contain additional length to help accommodate stretch or displacement. When the patch 100 is attached to a mammal, the slack in the wiring 120 allows the patch 100 to flex while not placing stress on the wiring 120.

[0044] While the illustrated embodiments of FIGS. 1A-1D show only two wings and show the electrodes and electronics in a direct line (i.e., in an approximate 180 degree alignment of electrode 124 to electronics 108 to electrode 126), other configurations are possible. For example, as shown in FIG. 1F, the wings 104, 106 are arranged in an orientation less than 180 degrees. In the illustrated embodiment, the angle formed by the electrodes and the electronics is about 135 degrees. Other ranges are possible so long as electrode spacing is provided to permit ECG monitoring. The orientation of the wings 104, 106 to the housing 102 also illustrates the use of an additional adhesive tab 105. Tab 105 is shown as a semicircular extension of the body 102. The bottom of tab 105 can include adhesives as described herein and is used to provide additional anchoring of the patch to the patient. The tab 105 may be formed in any of a number of different shapes such as rectangles, ovals, loops or strips. Further, in some embodiments, the tab 105 can function similar to a wing, e.g., include an electrode therethrough that connects to the electronics 108.

[0045] Referring to FIGS. 1A-1D and 2B-2C, a hinge portion 194, 196 in the patch 100 extends between each electrode 124, 126 and the electronics 108. The hinge portions 194, 196 can have a thickness less than the thickness of surrounding portions of the patch 100. For example, if the hinge portions 194, 196 are in the wings 104, 106, then the thickness can be less than adjacent portions of the wings. Likewise, the hinge portions 194, 196 can have a width less than adjacent portions of the patch 100, e.g., less than adjacent portions of the wings 104, 106. Alternatively, the hinged portion can be formed

by the adjunct between a rigid portion, i.e. the electronics 108, and a more flexible portion. The hinged portion allows the patch 100 to bend between the housing 102 and wings 104, 106 to compensate for any movement caused by the patient. As shown in FIGS. 2B and 2C, the slack in the wiring 120 can be placed at or proximal to the hinge portions 194, 196 to allow for bending at the hinge portions 194, 196 without pulling or breaking the wiring 120.

[0046] Referring to FIGS. 4A and 4B, having adhesive on the bottom of the patch 100 except in the areas substantially around the electrodes and directly underneath the housing 102 can create a floating section 455 over the skin of the mammal to which the patch 100 is attached. The floating section 455 can house the more rigid or less flexible electronic components while the flexible wings 104, 106 can be adhered to the skin and provide the flexibility necessary to hold the patch 100 in place. As a result of this selective use of adhesive areas and non-adhesive areas, the limitation on device flexibility imposed by the less flexible floating section can be mitigated or reduced by bounding the floating section with one or more adhered flexible areas. The flexible sections can thus adhere to the body if the underlying portion of the body is stretched and/or contracted while the floating section is free to move above the skin, for example if the person wearing the device rolls over (as shown in FIG. 4A) or is involved in activities that can otherwise cause movement of the skin (as shown in FIG. 4B).

[0047] Referring back to FIGS. 1B-1E, each wing 104, 106 can include a material layer 214, 216 between the adhesive 164, 166 and the wings 104, 106. The material layer 214, 216 can be, for example, a polyester layer. The material layer 214, 216 can be attached to the patch 100 with a layer of adhesive 204, 206. The adhesive 204, 206 can be the same as the adhesive 164, 166 or different. For example, the adhesive 204, 206 could be a silicone adhesive. The material layer 214 can serve as a barrier to prevent diffusion or migration of adhesive components, such as a tackifier, from the adhesive 164, 166 into the wings 104, 106 or housing 102. The material layer 214 can thus advantageously serve to maintain the strength of the adhesive 104, 106 over time.

[0048] Referring still to FIGS. 1B-1E, the patch 100 further includes a first flap 154 connected to the first wing 104 and a second flap 156 connected to the second wing 106. The flaps 154, 156 can both extend from a position on the wings 104, 106 medial to the electrodes to a position below the housing 102, such as below the electronics 108. The flaps 154, 156 remain unattached to the housing 102. As a result, gaps 144, 146 are formed between the flaps 134, 136 and the housing 102. The gaps can provide additional "floating" for the housing 102 and the relatively rigid components 108 contained therein.

[0049] In some embodiments, shown in FIG. 1B, the flaps 154, 156 can be attached to the wings 104, 106 with adhesive 134, 136. The adhesive 134, 136 can be the same as the adhesive 164, 166 or different. For example, the adhesive 134, 136 could be a silicone adhe-

sive. In other embodiments, shown in FIGS. 1C-1E, the flaps 154, 156 can be integral with the wings 102, 104. For example, the flaps 154, 156 can be solvent welded to and/or formed during the molding process of the wings 104, 106 such that hinges 184, 186 form below the wings 104, 106. Additionally or alternatively, one or more of the flaps 132, 136 may be separably attached to the wings 104, 106. In some embodiments, shown in FIGS. 1B and 1C, the materials making up the flaps 154, 156 can extend all the way to the lateral edge of the patch 100. In other embodiments, shown in FIG. 1D, a flap can extend on each side of the electrodes, i.e. one flap can extend medially and the other laterally. In some embodiments, the lateral and medial-extending flaps are part of the same annular flap. In other embodiments, shown in FIG. 1E, the flaps and materials making up the flaps extend only from a position medial to the electrodes underneath the housing.

[0050] The flaps 154, 156 may be positioned in virtually any relationship to the adhered flexible area such that, when attached in use, the attachment of the flap or flaps effectively counteracts the expected external forces acting on the device, specifically those forces that may dislodge the adhered flexible areas. Further, in embodiments such as that shown in FIG. 1F where there are more than two wings, there can be a flap corresponding to each additional wing.

[0051] The adhesive layers 164, 166 can coat all or a portion of the bottom of each of the flaps 124, 126. In some embodiments, the adhesive 164, 166 extends continuously from the bottom surface of the wings 104, 106 to the bottom surface of the flaps 154, 156, except for areas proximate to the electrodes 124, 126. Further, the top surface of the flaps 154, 156, i.e. the surface closest to the housing 102, can remain free of adhesive to ensure that the housing 102 remains floating. In some embodiments, the only portion of the patch 100 including adhesive for adhesion to the skin can be the flaps 154, 156.

[0052] Referring to FIGS. 5A-5C, the flaps 154, 156 can provide hinge-like behavior for the patch 100. Thus, as shown in FIG. 5A, if the skin 501 is stretched or bent in a concave manner, the gaps 144, 146 between the flaps 154, 156 and the housing 102 can approach zero such that the patch 100 can sit substantially flat on the skin 501. As shown, the hinge portions 194, 196 between the housing 102 and wings 104, 106 can provide additional flexibility for concave bends by flattening as the patch 100 is stretched. In contrast, as shown in FIGS. 5B and 5C, as the skin 501 is bent in an increasingly convex manner, the gaps 144, 146 between the flaps 154, 156 and the housing 102 can increase, thereby allowing the flexible wings 104, 106 to remain adhered to the skin and the rigid housing 102 to float above skin. As shown, the hinge portions 194, 196 between the housing and the wings 104, 106 can provide additional flexibility for convex bends by folding inward as the patch 100 is bent.

[0053] When placed substantially flat on the skin 501,

the patch 100 can have a height that extends no more than 2 cm off of the skin, such as no more than 1.5 cm off of the skin, when lying flat on the patient and no more than 4 cm, such as no more than cm off of the skin when floating above the skin. The relatively low height of the patch 100 can enhance long-term adhesion by reducing the potential for the patch 100 to snag or rip off of the skin.

[0054] Advantageously, the flaps 154, 156 can function as anchors for adhesion that mitigates shear force. The flaps 154, 156 can provide a different direction for the acute and chronic forces being experienced by the device due to stretching, contraction, or torsion to be spread out over both the flap as well as the flexible adhesive areas. Further, by pre-aligning the orientation of the floating section, adhered flexible area and the flaps, the device may be better able to tolerate (i.e., remain attached to the body and in use) and/or tailor the interaction with the forces acting on the device in order to better withstand the acute or chronic forces being experienced by the device. Tailoring the response of the device to the expected forces is one factor in improving the likelihood of long-term device adhesion.

[0055] Because the flaps can be used to counteract forces acting on a particular device, it is to be appreciated that the dimensions, flexibility, attachment technique, and/or orientation between a flap and another component may vary depending upon the purpose of a particular flap. Accordingly, a flap may have the same or different characteristics from another flap or component of the device. In one aspect, at least one flap is more flexible than the other flaps in a particular device. In another aspect, each of the flaps has similar flexibility. In still another aspect, at least one flap is more flexible than the device component to which it is attached or from which it originates. In still another aspect, at least one flap is less flexible than the device component to which it is attached or from which it originates.

[0056] Referring to FIGS. 6A and 6B, in one embodiment, the flaps 154, 156 may be augmented by a connector segment 607 used to join the flaps together. The connector segment 607 can extend below the housing 102, but remain unattached to the housing 102. As shown in FIG. 6A, the flaps 154, 156 and the connector 607 can together form a butterfly shape. In one embodiment, the connector segment 607 and the flaps 154, 156 are formed from a single piece of material. The connector segment 607 can be made of the same material as the flaps 154, 156 or of different material. In one embodiment, the bottom surface of the connector is covered with adhesive. In another embodiment, the bottom surface of the connector does not include any adhesive. Further, as shown in FIG. 6B, the connector segment 607 can be thicker in the middle, under the housing 102, than near the edges, i.e., closer to the electrodes. The variable thickness can help prevent the connector segment 607 from capturing moisture thereunder. The connector segment 607 can advantageously prevent the device from flipping when attached to the patient.

[0057] The connector segment 607 can include one or more holes 614, 616. In some configurations, the connector segment may trap moisture and/or inadvertently stick to the body. The holes 614, 616 can advantageously minimize the potential for undesired sticking or moisture collection. The size, shape and placement of the holes mitigate or reduce the collection of moisture and/or undesired adhesive still providing a connector with sufficient structural integrity (i.e. the connector allows the flaps to be connected to one another in order to prevent them from folding). Additionally or alternatively, the connector holes could also be made to also preferentially allow forces to be distributed along certain axes of the connector in order to further maximize the ability of the device to adhere long-term in the face of significant acute and chronic forces due to stretching, contraction, and torsion.

[0058] Adhesive can be selectively applied to the connector and/or flaps to provide the desired body attachment locations depending upon the specific use of the device. For example, one piece of material including flaps and the connector can be adhered along two or more edges and/or with adhesive only covering certain areas. In another aspect, at least a portion of the skin-contacting surface of the unitary flap connector structure does not include any adhesive. Additionally or alternatively, the connector segment incorporating the flaps may be integral parts of the larger device housing (e.g. could be molded as part of the device housing or enclosure).

[0059] In some embodiments, the patch 100 can include one or more release liners to cover parts of the adhesive prior to adhesion. As is particular to devices having multiple adhesive areas and/or multiple adhesive components (i.e., flaps and flexible sections), the manner of applying the device may be specifically detailed in order to ensure that the device and the adhesive portions are properly engaged. In one particular aspect, the release liners are removed in a particular order to minimize the likelihood that the device adhesive is misapplied. For example, a portion of the adhesive may be exposed first and used to affix the device to the body. Thereafter, a second set of adhesive liners may be removed to expose and affix one or more flaps to the body. A stepwise adhesive exposure method may be implemented during device application such that elements, such as the one or more flaps do not fold on themselves, for example.

[0060] Breaking up the areas in which the adhesive is used to adhere the device, whether it be splitting it up to rigid areas, to create flaps, to create connector segments with holes, of any of the other techniques described above may also have benefits in terms of preventing moisture bridges that could act as conducting pathways between electrical sensing elements, such as electrodes. Bridges of moisture could short-circuit electrical connections and/or prevent the proper functioning of the device, particularly if the device has an electrical function, such as sensing via electrodes.

[0061] In some applications, a long-duration patch may experience excessive forces due to acute (quick and/or

rapid) or chronic (stow and/or prolonged) contraction, stretching, or torsion. In such applications, the hinge points between a floating rigid section and flexible adhered sections may be modified in order to align with and counteract or mitigate the predominate direction of the force acting on the patch. In some device situations or configurations, the strength and direction of the acute or chronic force may be so strong that the forces imparted on the device adhesive surfaces or components may be distributed differently in addition to or as an alternative to the hinge described above.

[0062] Further, the device construction can be made in such a way that the housing is fashioned so that the axes of the housing are structured and placed along or against the direction of various forces, possibly during certain states, such as sleeping, so that the device itself can help counteract these forces and improve long-term adhesion.

[0063] Advantageously, the patch described herein can provide long-term adhesion to the skin. Having the various flexible portions and/or hinged portions can compensate for stress caused as the skin stretches or bends, while allowing the rigid portion to float about the skin. As a result, the devices described herein can adhere to the skin substantially continuously for more than 24 hours, such as greater than 3 days, for example, greater than 7 days, greater than 14 days, or greater than 21 days.

[0064] Another mechanism for adhering a patch to the skin long-term is described with respect to FIGS. 7-10. As shown in the embodiments of FIGS. 7-10, one or more parts of the patch are used in a temporary fashion in order to improve adhesion. The adhesive used in the embodiments described below can include a hydrocolloid or a pressure-sensitive adhesive, such as polyacrylate, polyisobutylenes, or polysiloxane.

[0065] In one embodiment, shown in FIGS. 7A and 7B, the patch 700 can be surrounded with an adhesive 760 having multiple covers 701, 703, 705 thereon that can be peeled away in a sequence to expose strips of adhesive 760 underneath. The covers 701, 703, 705 can be concentric with one another and be configured to be pulled off separately and sequentially starting from the inside of the patch 700. Each additional exposed area of adhesive 760 can increase the adhesion life of the patch 700. Although only three covers are shown in FIG. 7A, other numbers, such as 2, 4, 5, or more are possible. Further, each electrode 124, 126 of the patch 700 can include a barrier 714, 716 to protect the electrodes 124, 126 from shortage.

[0066] In another embodiment, shown in FIGS. 8A and 8B, each electrode 124, 126 can be surrounded by a patch of adhesive 864, 866. Accordingly, a set of covers 801, 803, 805, 807 can be positioned sequentially around each of the electrodes 124, 126 over the adhesive 864, 866. The covers 801, 803, 805, 807 can be concentric with one another and be configured to be pulled off sequentially starting from the inside. Each additional exposed strip of adhesive 864, 866 can increase the adhe-

sion life of the patch 100. Although only four covers are shown in FIG. 8A, other numbers, such as 2, 3, 5, or more are possible. Further, each electrode 124, 126 of the patch 800 can include a barrier 814, 816 to protect from shortage.

[0067] Referring to FIGS. 9A-9B, in other embodiments, shells or layers 901, 902, 903 can extend over all or a portion of the patch 900. Each layer 901, 902, 903 can include a strip of adhesive 962 on the bottom surface and an adhesion guard 982 protecting the adhesive. As shown in FIG. 9B, as the patch 900 is worn over a period of time, the layers 901, 902, 903 can be sequentially removed. As a new layer is exposed, the adhesive guard 982 of that layer can be peeled away such that the adhesive 962 of the new layer can be used to adhere the patch 900 to the skin. In a similar embodiment, referring to FIGS. 10A-10B, each of the layers 1001, 1002, 1003 can include multiple portions of adhesive to help adhere the layer to both the skin and the patch itself. As with the embodiments of FIGS. 7-8, the number of layers in the embodiments of FIGS. 9 and 10 can vary. For example, there can be 2, 3, 4, or 5 or more layers.

[0068] In some embodiments, the layers or covers of the embodiments described herein can be added to the device over time to improve adhesion. Further, the multiple layers or covers of the embodiments described herein can be partially overlapped. Further, in some embodiments, the strips of adhesive can be overlapped.

[0069] Advantageously, the use of multiple covers or layers can assist in the adhesive performance of a base or core device because the added surface area or adhesive force of the combined outer layer aids in preventing layer pull away and/or may act to spread forces being experienced away from the core device by spreading those forces over a larger area.

[0070] Referring to FIGS. 11 and 12, an open cell structured support 1330 or porous foam can be used to support a more rigid or less flexible portion 1302 of the patch 1300. As shown in FIG. 11, the open cell structured support 1330 can fully fill an area below the rigid portion 1302. Alternatively, as shown in FIG. 12, the open cell structured support 1330 can be an annular shape or have some other configuration that includes spaces between adjacent portions of the support. The open cell structured support 1302 may be attached to both the skin and to the rigid portion, to only the rigid portion, or to only the skin. Because of the open cell structure of the support, the flexible movement of the skin can be absorbed by the structure entirely or partially such that the rigid portion does not impact or has a reduced impact on the ability of the device to accommodate movement and remain affixed. In addition, the open cell support may have a thickness selected to enhance patient comfort so that the more rigid portion of a device does not push against the skin. In one aspect, the open cell structure is a biocompatible foam material. In another aspect, the open cell material is positioned between an electronics module on the device and the skin when worn by a patient. The open

cell support can advantageously absorb fluids to keep the electrodes from shorting.

[0071] Referring to FIG. 13, the patch can have a shell design. Adhesive can be placed on the perimeter edge of the bottom ring. The circuit board and electrode unit can be dropped into the bottom ring, and a shell can be dropped on top of the circuit board and electrode. The perimeter adhesive can create a watertight chamber therein.

[0072] The shape of a particular electronic device embodiment may vary. The shape, footprint, perimeter or boundary of the device may be a circle or circular (see FIG. 13A), an oval (see FIG. 1A, 2A), a triangle or generally triangular (see FIG. 1F) or a compound curve. Examples of device embodiments having a compound curve shape are shown in FIGS. 2B, 2C, 3, 6A, 7A and 8A. In some embodiments, the compound curve includes one or more concave curves and one or more convex curves. FIG. 3 illustrates a device having a convex surface along the top (where reference 102 indicates), a concave surface along the bottom and convex shaped edges around the electrodes 124, 126. FIGS. 2B and 2C illustrate a device embodiment having a convex shape on either side of the electronics 108 and around the electrodes 124, 126. The convex shapes are separated by a concave portion. The concave portion is between the convex portion on the electronics and the convex portion on the electrodes. In some embodiments, the concave portion corresponds at least partially with a hinge, hinge region or area of reduced thickness between the body and a wing.

[0073] While described in the context of a heart monitor, the device adhesion improvements described herein are not so limited. The improvement described in this application may be applied to any of a wide variety of conventional physiological data monitoring, recording and/or transmitting devices. The improved adhesion design features may also be applied to conventional devices useful in the electronically controlled and/or time released delivery of pharmacological agents or blood testing, such as glucose monitors or other blood testing devices. As such, the description, characteristics and functionality of the components described herein may be modified as needed to include the specific components of a particular application such as electronics, antenna, power supplies or charging connections, data ports or connections for down loading or off loading information from the device, adding or offloading fluids from the device, monitoring or sensing elements such as electrodes, probes or sensors or any other component or components needed in the device specific function. In addition or alternatively, devices described herein may be used to detect, record, or transmit signals or information related to signals generated by a body including but not limited to one or more of EKG, EEG and/or EMG.

Claims

1. An electronic device (100) for long-term adhesion to a mammal, the device comprising:
 - 5 a housing (102) forming a water-tight enclosure:
 - a rigid physiologic data collection circuit (108) contained in the housing;
 - a first wing (104) and a second wing (106) extending laterally from the housing without overlapping, wherein each wing includes a hinge portion (194, 196) adjacent the housing;
 - a first electrode positioned on the bottom surface of the first wing and a second electrode positioned on the bottom surface of the second wing, the electrodes electronically connected to the physiologic data collection circuit (108);
 - an adhesive layer (164, 166) on the bottom surfaces of the wings and not on a bottom surface of the housing, wherein the adhesive layer provides adhesion to the surface of the mammal, and wherein the housing is unattached to the mammal when the electrodes are in contact with the mammal;
 - characterized in that** the device further comprises a first flap (154) connected to the first wing and a second flap (156) connected to the second wing, wherein the flaps extend below the housing, but are not attached to the housing, which allows the housing to float above the wings when the electrodes are in contact with the mammal, wherein the rigid physiologic data collection circuit (108) extends along only a portion of the distance between the electrodes (124, 126).
2. The electronic device (100) of claim 1, wherein the wings (104, 106) are more flexible than the housing (102).
3. The electronic device (100) of claim 1, wherein the wings (104, 106) and the housing (102) are made from the same material or from different materials.
4. The electronic device (100) of claim 1, wherein each hinge portion (194, 196) is thinner than an adjacent portion of the wing (104, 106) of which it is a part.
5. The electronic device (100) of claim 1, wherein the adhesive layer (164, 166) is coated on a bottom surface of each flap (154, 156).
6. The electronic device (100) of claim 5, further comprising a connector segment (607) configured to connect the flaps (154, 156) together without attaching to the housing (102).
7. The electronic device (100) of claim 1, further comprising a second adhesive layer (962) with an adhe-

sion guard (982) protecting the adhesive, optionally wherein the second adhesive layer adds adhesive surface area to the first adhesive layer to distribute forces over a larger area.

8. The electronic device (100) of claim 1, wherein the adhesive comprises an adhesive that can absorb fluids, optionally wherein the adhesive comprises a hydrocolloid adhesive.

9. The electronic device (100) of claim 1, wherein the adhesive comprises a pressure-sensitive adhesive, optionally wherein the pressure sensitive adhesive is selected from the group consisting of a polyacrylate, a polyisobutylene and a polysiloxane.

10. The electronic device (100) of claim 1, further comprising:

an additional adhesive layer (204, 206) between the wing (104, 106) and the adhesive layer; and a material layer (214, 216) between the wing and the adhesive layer.

11. The electronic device (100) of claim 1, further comprising at least one additional wing extending from the housing without overlapping the two wings (104, 106).

12. The electronic device (100) of claim 1, wherein the rigid physiologic data collection circuit (108) is configured to collect cardiac rhythm data from the mammal.

Patentansprüche

1. Elektronische Vorrichtung (100) zum langzeitigen Kleben an einem Säugetier, wobei die Vorrichtung Folgendes umfasst:
ein Gehäuse (102), das eine wasserdichte Kapsel bildet:

eine in dem Gehäuse enthaltene, starre physiologische Datenerfassungsschaltung (108);
einen ersten Flügel (104) und einen zweiten Flügel (106), die sich ohne zu überlappen lateral von dem Gehäuse erstrecken, wobei jeder Flügel einen Scharnierabschnitt (194, 196) neben dem Gehäuse aufweist;

eine erste Elektrode, die an der Bodenfläche des ersten Flügels positioniert ist, und eine zweite Elektrode, die an der Bodenfläche des zweiten Flügels positioniert ist, wobei die Elektroden elektronisch mit der physiologischen Datenerfassungsschaltung (108) verbunden sind;
eine Klebstoffschicht (164, 166) an den Bodenflächen der Flügel und nicht an einer Bodenflä-

che des Gehäuses, wobei die Klebstoffschicht Haftung an der Oberfläche des Säugetiers bietet und wobei das Gehäuse nicht an dem Säugetier angebracht ist, wenn die Elektroden mit dem Säugetier in Kontakt sind;

dadurch gekennzeichnet, dass die Vorrichtung ferner eine mit dem ersten Flügel verbundene erste Klappe (154) und eine mit dem zweiten Flügel verbundene zweite Klappe (156) umfasst, wobei die Klappen unterhalb des Gehäuses verlaufen, aber nicht am Gehäuse angebracht sind, so dass das Gehäuse über den Flügeln schweben kann, wenn die Elektroden mit dem Säugetier in Kontakt sind,
wobei die starre physiologische Datenerfassungsschaltung (108) nur entlang einem Teil der Distanz zwischen den Elektroden (124, 126) verläuft.

2. Elektronische Vorrichtung (100) nach Anspruch 1, wobei die Flügel (104, 106) flexibler sind als das Gehäuse (102).

3. Elektronische Vorrichtung (100) nach Anspruch 1, wobei die Flügel (104, 106) und das Gehäuse (102) aus demselben Material oder aus unterschiedlichen Materialien gefertigt sind.

4. Elektronische Vorrichtung (100) nach Anspruch 1, wobei jeder Scharnierabschnitt (194, 196) dünner ist als ein benachbarter Abschnitt des Flügels (104, 106), von dem er ein Teil ist.

5. Elektronische Vorrichtung (100) nach Anspruch 1, wobei die Klebstoffschicht (164, 166) auf einer Bodenfläche jeder Klappe (154, 156) aufgetragen ist.

6. Elektronische Vorrichtung (100) nach Anspruch 5, die ferner ein Verbindersegment (607) umfasst, das zum Verbinden der Klappen (154, 156) miteinander konfiguriert ist, ohne sie am Gehäuse (102) anzubringen.

7. Elektronische Vorrichtung (100) nach Anspruch 1, die ferner eine zweite Klebstoffschicht (962) mit einem den Klebstoff schützenden Haftschutz (982) umfasst, wobei die zweite Klebstoffschicht optional der ersten Klebstoffschicht Klebstoffflächenbereich hinzufügt, um Kräfte über einen größeren Bereich zu verteilen.

8. Elektronische Vorrichtung (100) nach Anspruch 1, wobei der Klebstoff einen Klebstoff umfasst, der Fluide absorbieren kann, wobei der Klebstoff optional einen Hydrokolloidklebstoff umfasst.

9. Elektronische Vorrichtung (100) nach Anspruch 1, wobei der Klebstoff ein Haftkleber ist, wobei der Haft-

kleber optional ausgewählt ist aus der Gruppe bestehend aus einem Polyacrylat, einem Polyisobutylen und einem Polysiloxan.

10. Elektronische Vorrichtung (100) nach Anspruch 1, die ferner Folgendes umfasst:

eine zusätzliche Klebstoffschicht (204, 206) zwischen dem Flügel (104, 106) und der Klebstoffschicht; und
eine Materialschicht (214, 216) zwischen dem Flügel und der Klebstoffschicht.

11. Elektronische Vorrichtung (100) nach Anspruch 1, die ferner wenigstens einen zusätzlichen Flügel umfasst, der sich ohne Überlappung der beiden Flügel (104, 106) von dem Gehäuse erstreckt.

12. Elektronische Vorrichtung (100) nach Anspruch 1, wobei die starre physiologische Datenerfassungsschaltung (108) zum Erfassen von Herzrhythmusdaten von dem Säugetier konfiguriert ist.

Revendications

1. Dispositif électronique (100) pour une adhérence à long terme à un mammifère, le dispositif comprenant :

un boîtier (102) formant une enceinte étanche à l'eau ;

un circuit rigide de collecte de données physiologiques (108) contenu dans le boîtier ;

une première ailette (104) et une seconde ailette (106) s'étendant latéralement depuis le boîtier sans se chevaucher, dans lequel chaque ailette comporte une portion d'articulation (194, 196) adjacente au boîtier ;

une première électrode positionnée sur la surface de dessous de la première ailette et une seconde électrode positionnée sur la surface de dessous de la seconde ailette, les électrodes étant connectées électroniquement au circuit de collecte de données physiologiques (108) ;

une couche d'adhésif (164, 166) sur les surfaces de dessous des ailettes et non sur une surface de dessous du boîtier, dans lequel la couche d'adhésif assure l'adhérence à la surface du mammifère, et dans lequel le boîtier est non fixé au mammifère lorsque les électrodes sont en contact avec le mammifère ;

caractérisé en ce que le dispositif comprend en outre un premier rabat (154) raccordé à la première ailette et un second rabat (156) raccordé à la seconde ailette, dans lequel les rabats s'étendent en dessous du boîtier, mais ne sont pas fixés au boîtier, ce qui permet au boîtier de

flotter au-dessus des ailettes lorsque les électrodes sont en contact avec le mammifère, dans lequel le circuit rigide de collecte de données physiologiques (108) s'étend le long uniquement d'une portion de la distance entre les électrodes (124, 126).

2. Dispositif électronique (100) selon la revendication 1, dans lequel les ailettes (104, 106) sont davantage flexibles que le boîtier (102).

3. Dispositif électronique (100) selon la revendication 1, dans lequel les ailettes (104, 106) et le boîtier (102) sont réalisés à partir du même matériau ou de matériaux différents.

4. Dispositif électronique (100) selon la revendication 1, dans lequel chaque portion d'articulation (194, 196) est plus mince qu'une portion adjacente de l'ailette (104, 106) dont elle fait partie.

5. Dispositif électronique (100) selon la revendication 1, dans lequel la couche d'adhésif (164, 166) est revêtue sur une surface de dessous de chaque rabat (154, 156).

6. Dispositif électronique (100) selon la revendication 5, comprenant en outre un segment de raccord (607) configuré pour raccorder les rabats (154, 156) ensemble sans fixation au boîtier (102).

7. Dispositif électronique (100) selon la revendication 1, comprenant en outre une seconde couche d'adhésif (962) avec un dispositif de protection d'adhérence (982) protégeant l'adhésif, facultativement dans lequel la seconde couche d'adhésif ajoute une superficie d'adhésif à la première couche d'adhésif pour répartir les forces sur une zone plus grande.

8. Dispositif électronique (100) selon la revendication 1, dans lequel l'adhésif comprend un adhésif qui peut absorber des fluides, facultativement dans lequel l'adhésif comprend un adhésif hydrocolloïde.

9. Dispositif électronique (100) selon la revendication 1, dans lequel l'adhésif comprend un adhésif sensible à la pression, facultativement dans lequel l'adhésif sensible à la pression est choisi dans le groupe consistant en un polyacrylate, un polyisobutylène et un polysiloxane.

10. Dispositif électronique (100) selon la revendication 1, comprenant en outre :

une couche d'adhésif supplémentaire (204, 206) entre l'ailette (104, 106) et la couche d'adhésif ; et
une couche de matériau (214, 216) entre l'ailette

et la couche d'adhésif.

11. Dispositif électronique (100) selon la revendication 1, comprenant en outre au moins une ailette supplémentaire s'étendant depuis le boîtier sans chevaucher les deux ailettes (104, 106). 5
12. Dispositif électronique (100) selon la revendication 1, dans lequel le circuit rigide de collecte de données physiologiques (108) est configuré pour collecter des données de rythme cardiaque auprès du mammifère. 10

15

20

25

30

35

40

45

50

55

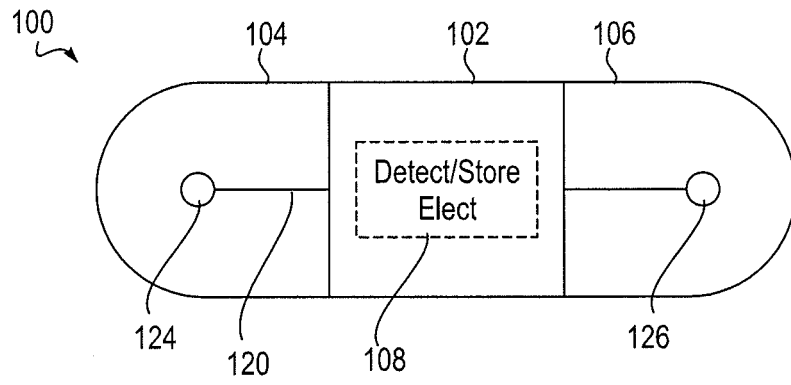

FIG. 1

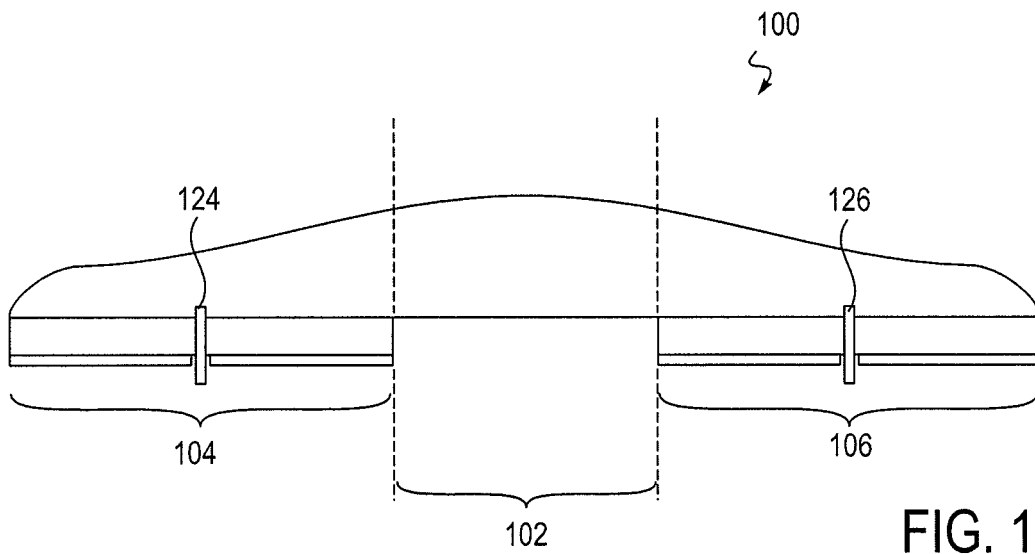

FIG. 1A

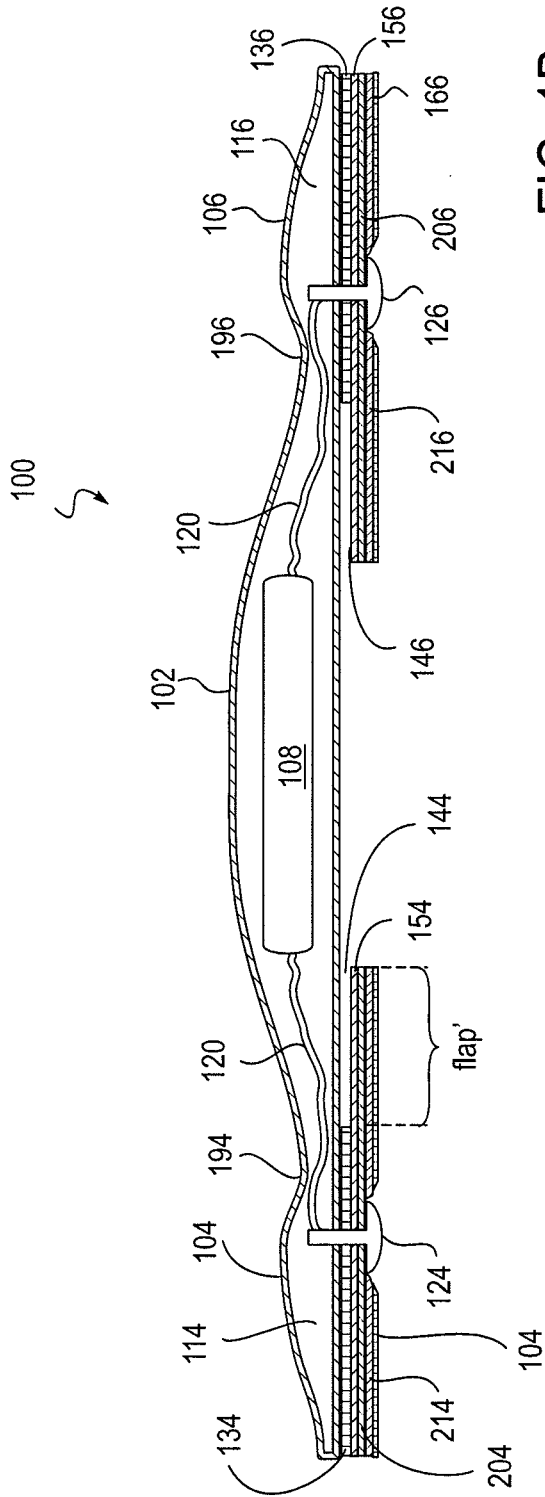

FIG. 1B

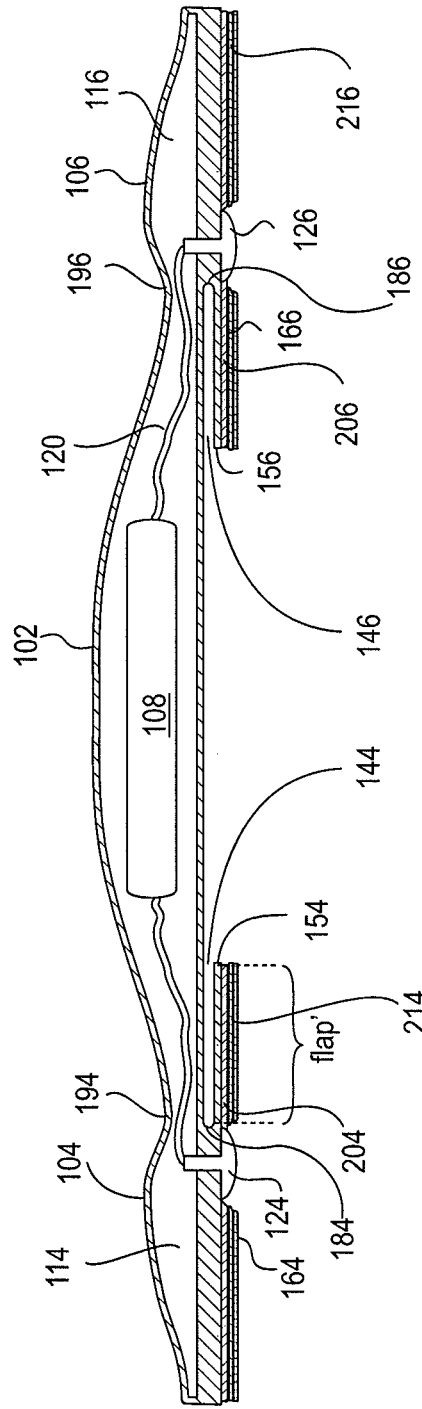

FIG. 1C

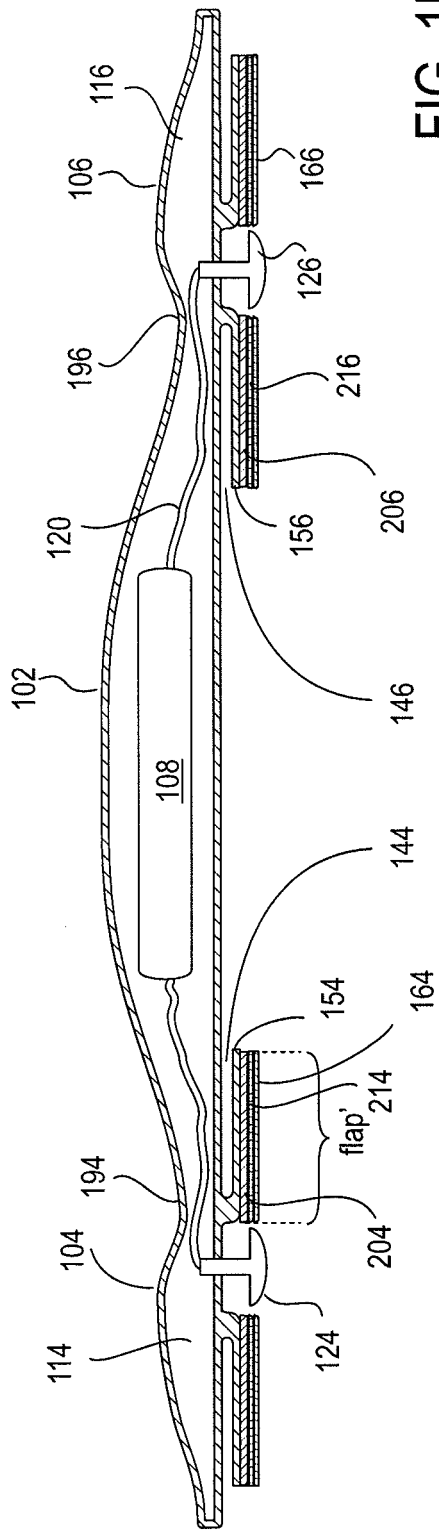

FIG. 1D

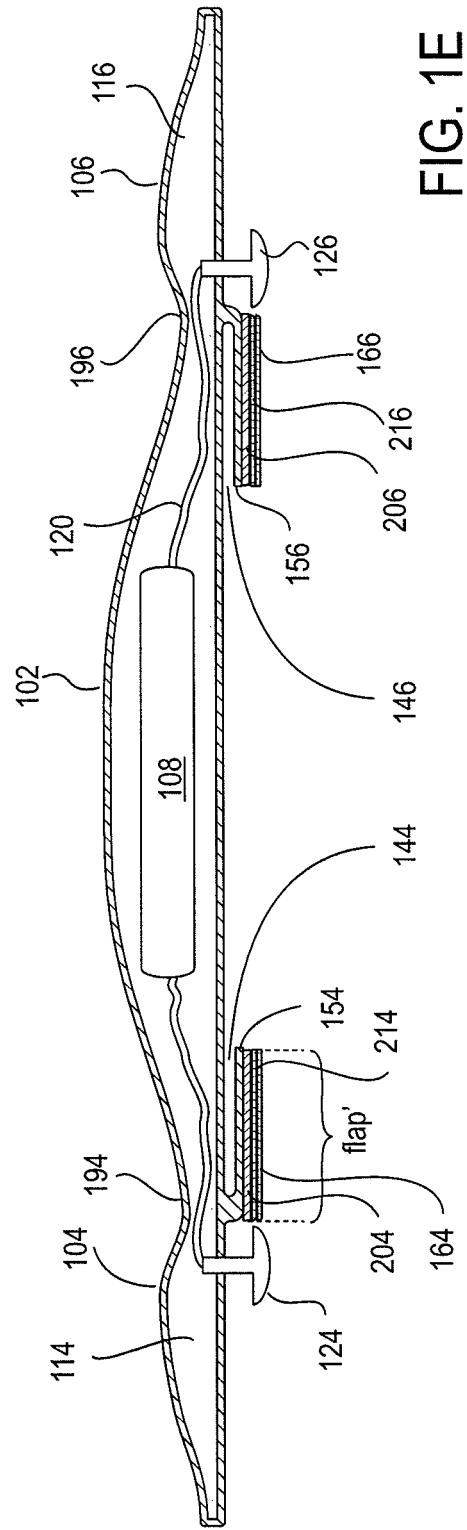

FIG. 1E

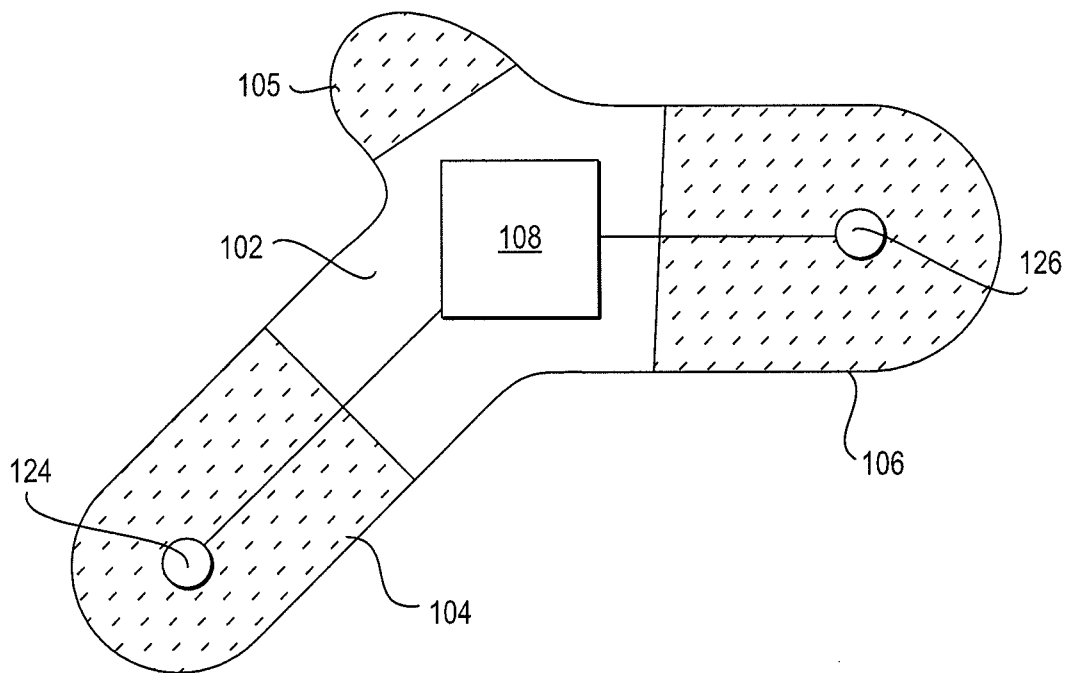

FIG. 1F

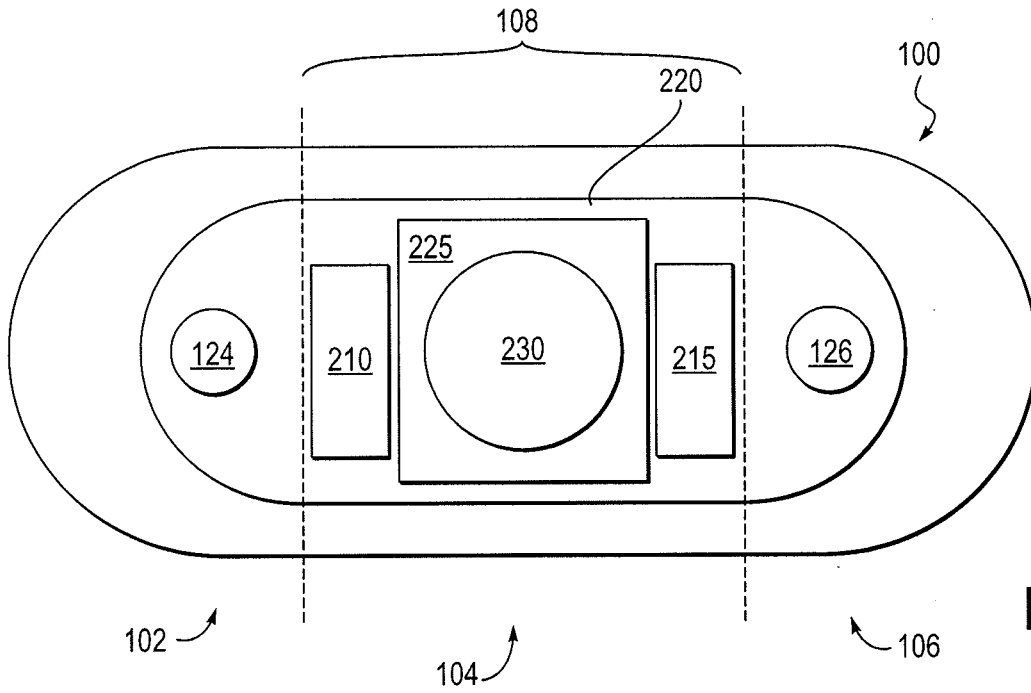

FIG. 2A

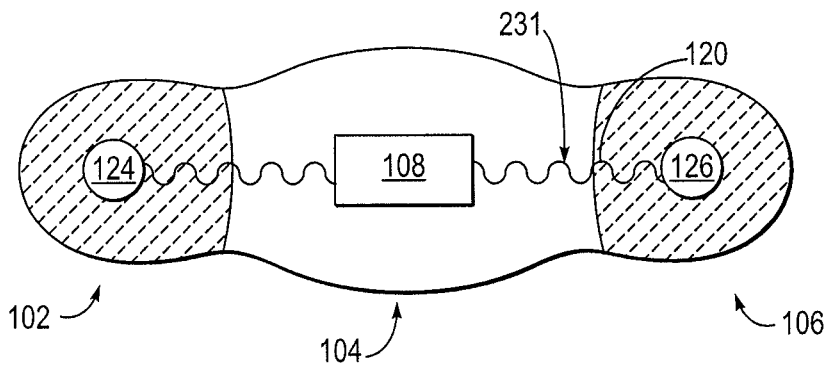

FIG. 2B

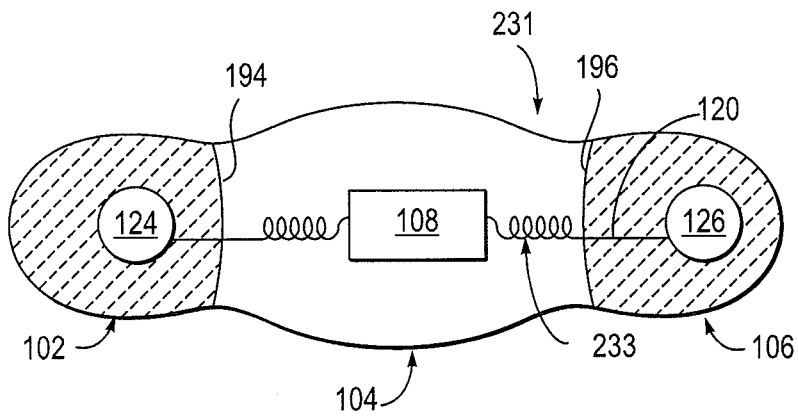

FIG. 2C

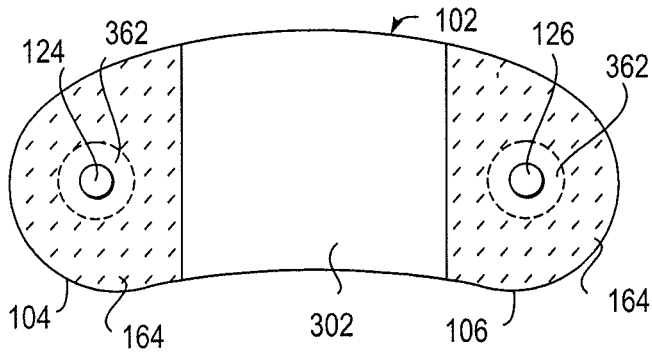

FIG. 3

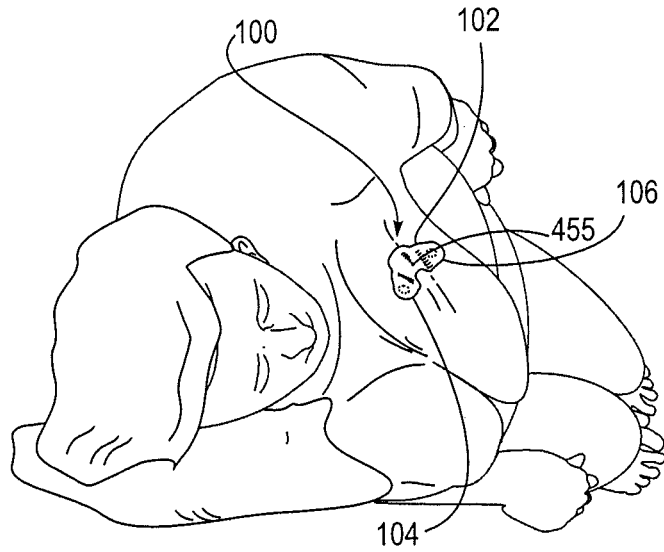

FIG. 4A

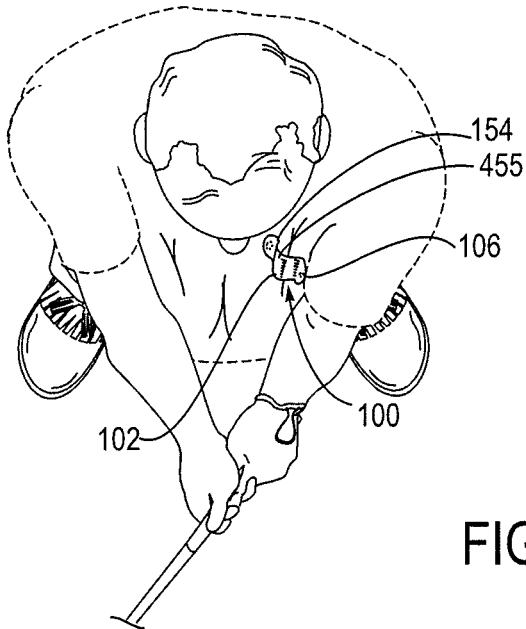

FIG. 4B

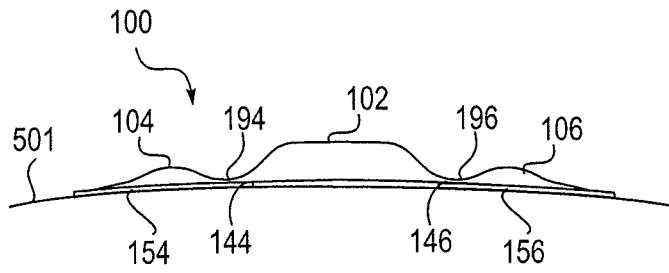

FIG. 5A

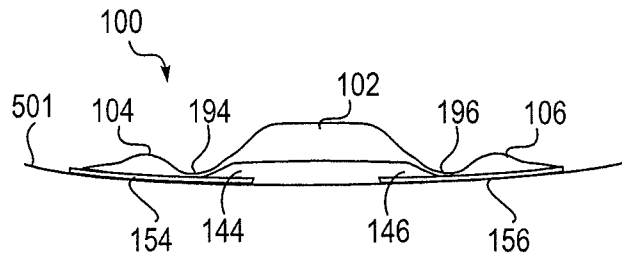

FIG. 5B

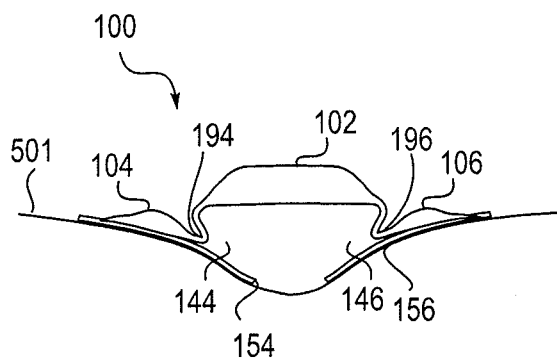
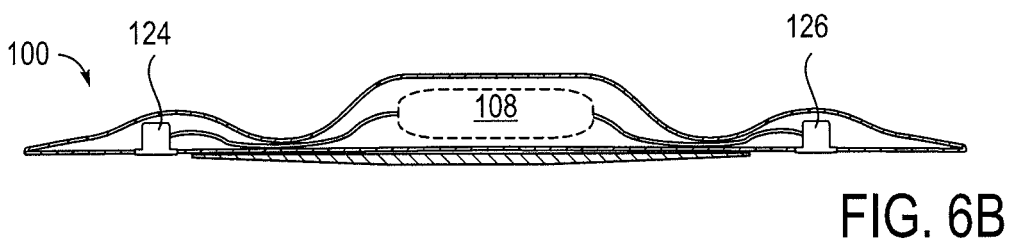
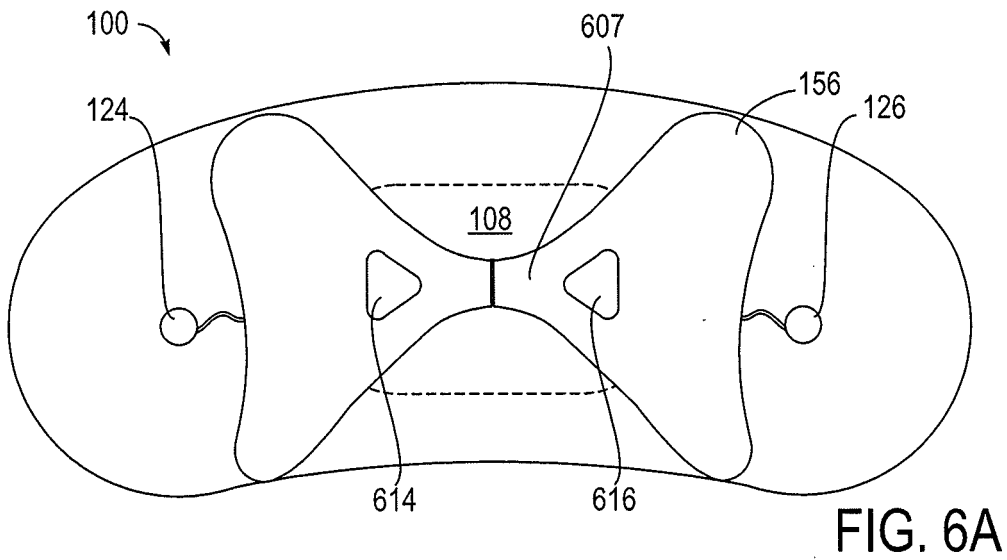

FIG. 5C



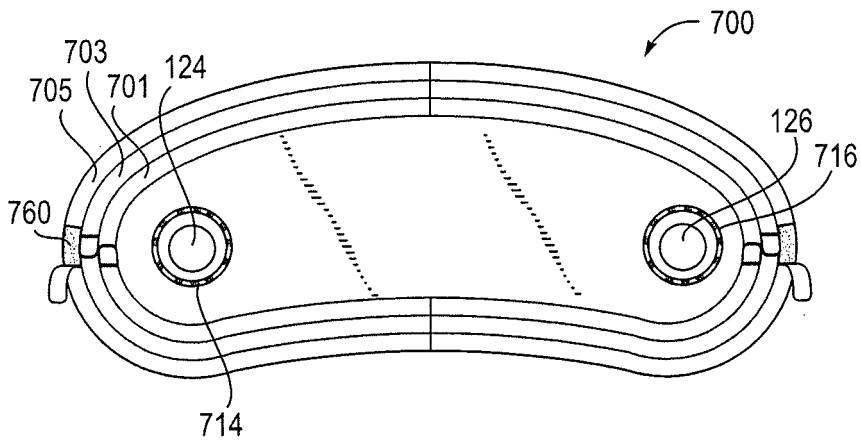

FIG. 7A

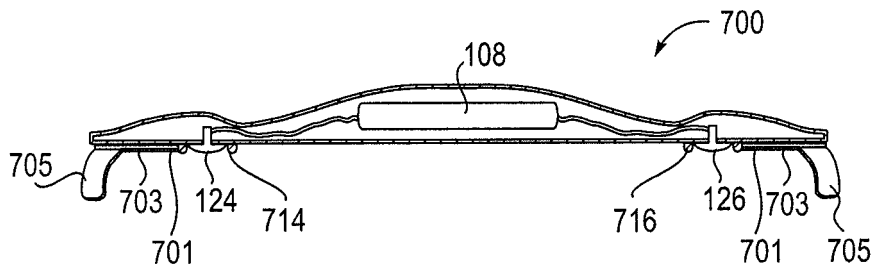

FIG. 7B

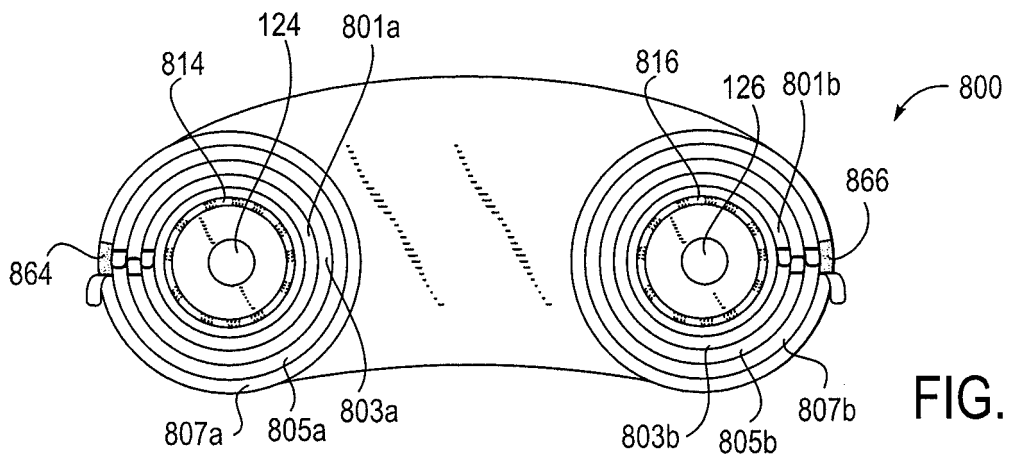

FIG. 8A

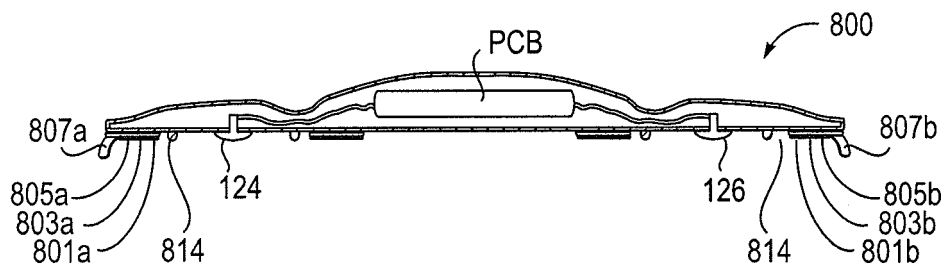

FIG. 8B

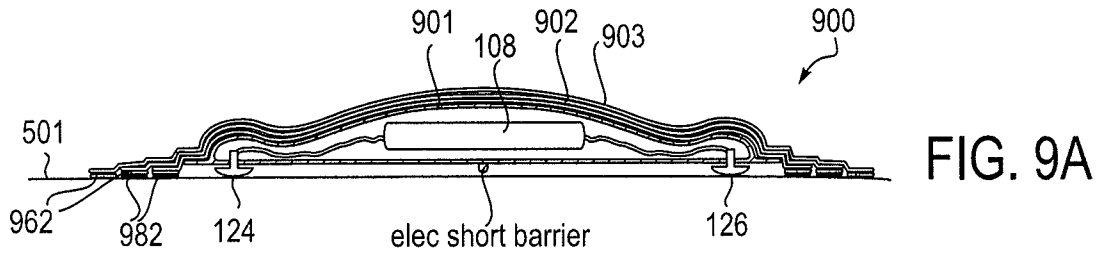

FIG. 9A

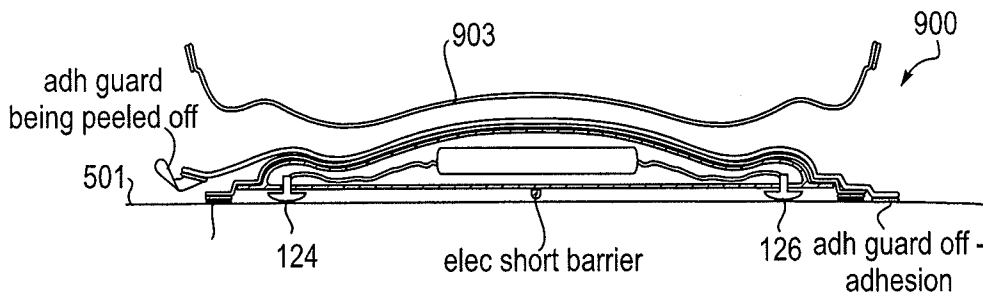

FIG. 9B

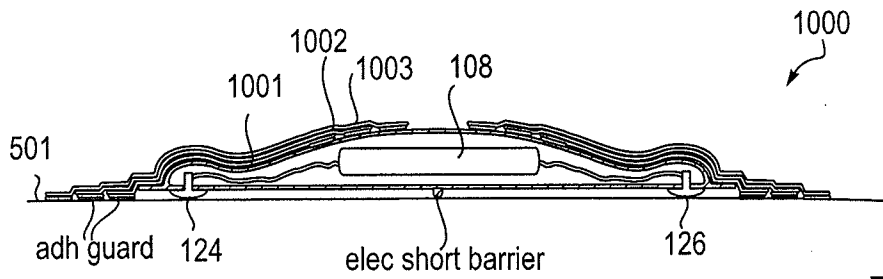

FIG. 10A

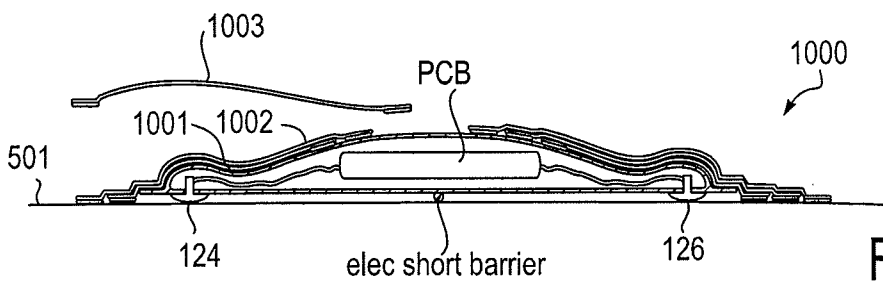

FIG. 10B

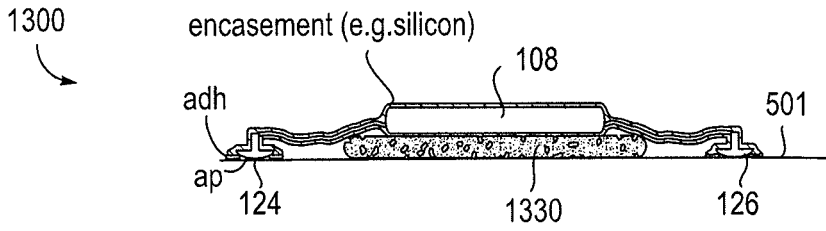

FIG. 11

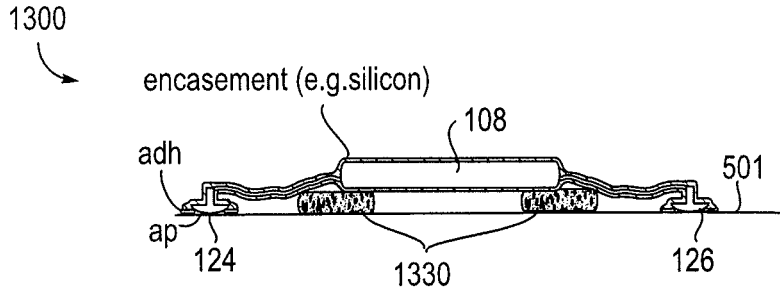

FIG. 12

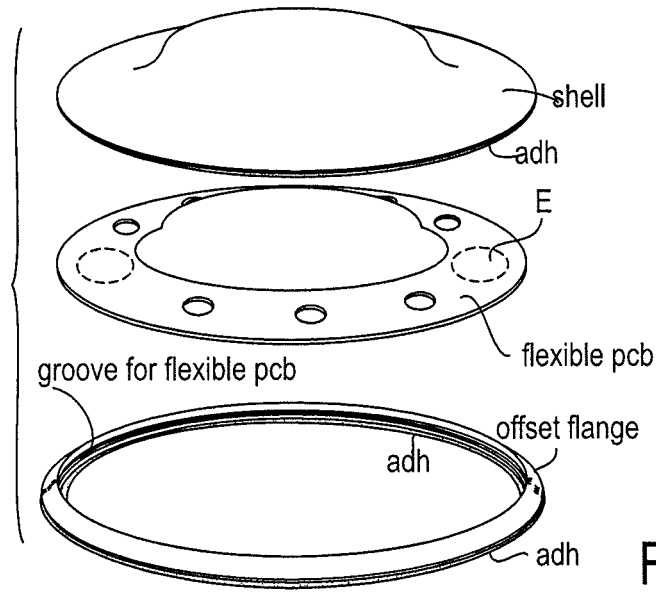

FIG. 13A

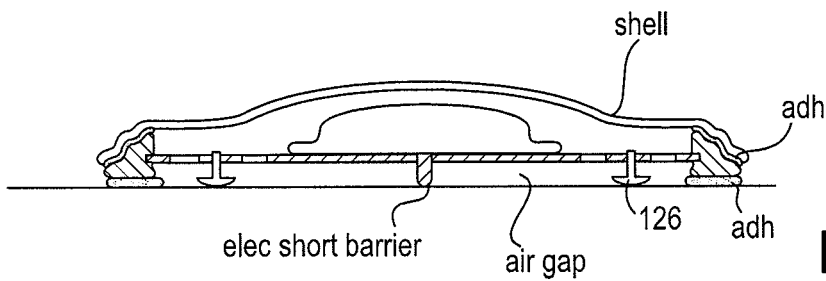

FIG. 13B

REFERENCES CITED IN THE DESCRIPTION

This list of references cited by the applicant is for the reader's convenience only. It does not form part of the European patent document. Even though great care has been taken in compiling the references, errors or omissions cannot be excluded and the EPO disclaims all liability in this regard.

Patent documents cited in the description

- US 20070249946 A [0035]
- WO 2009055397 A [0036]

专利名称(译)	设备特征和设计元素，用于长期粘合		
公开(公告)号	EP2568878B1	公开(公告)日	2018-07-25
申请号	EP2011781310	申请日	2011-05-12
申请(专利权)人(译)	IRHYTHM TECHNOLOGIES , INC.		
当前申请(专利权)人(译)	IRHYTHM TECHNOLOGIES , INC.		
[标]发明人	KUMAR UDAY N LIVINGSTON PETER H DAY MARK J PARK SHENA H WILLIS WILLIAM F RIGHTER WILLIAM H		
发明人	KUMAR, UDAY, N. LIVINGSTON, PETER, H. DAY, MARK, J. PARK, SHENA, H. WILLIS, WILLIAM, F. RIGHTER, WILLIAM, H.		
IPC分类号	A61B5/0478 A61B5/00 A61B5/0408 B31B50/62		
CPC分类号	A61B5/0408 A61B5/0478 A61B5/6833 A61B5/68335 A61B2560/0406 A61B2560/0468 Y10T156/10 A61B5/04085 A61B5/04087 A61B5/0488 A61B5/6832		
代理机构(译)	POTTER CLARKSON LLP		
优先权	61/334081 2010-05-12 US		
其他公开文献	EP2568878A2 EP2568878A4		
外部链接	Espacenet		

摘要(译)

一种用于长期粘附于哺乳动物的电子装置，该装置包括：壳体，其中包含电子元件；至少两个与壳体成一体的翼；位于每个翼的底表面上的电极，电极电连接到电子元件；涂覆在翼的底表面的一部分上的粘合剂层，其中粘合剂层未涂覆在电极上或壳体的底表面上。

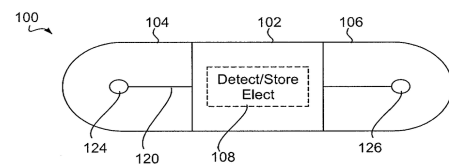

FIG. 1

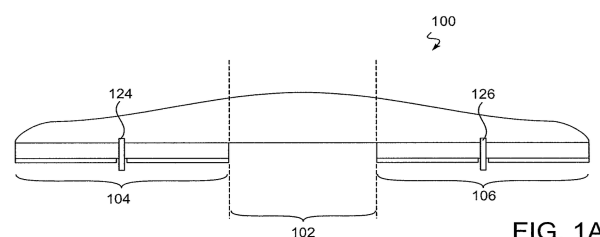

FIG. 1A