



(11) **EP 1 955 649 B1**

(12) **EUROPEAN PATENT SPECIFICATION**

(45) Date of publication and mention of the grant of the patent:  
**28.12.2011 Bulletin 2011/52**

(51) Int Cl.:  
**A61B 5/00** (2006.01) **A61B 5/22** (2006.01)  
**A61N 5/06** (2006.01) **G02B 26/08** (2006.01)  
**G02B 6/36** (2006.01)

(21) Application number: **08102902.7**

(22) Date of filing: **11.11.2002**

(54) **System for interactive interstitial photodynamic and photothermal tumor therapy and diagnosis**

System für die interaktive interstitielle, photodynamische und photothermische Tumortherapie und -Diagnose

Système pour thérapie et diagnostic interactif photodynamique interstitiel et photothermique des tumeurs

(84) Designated Contracting States:  
**AT BE BG CH CY CZ DE DK EE ES FI FR GB GR  
IE IT LI LU MC NL PT SE SK TR**

(30) Priority: **14.11.2001 SE 0103771**

(43) Date of publication of application:  
**13.08.2008 Bulletin 2008/33**

(62) Document number(s) of the earlier application(s) in accordance with Art. 76 EPC:  
**02789052.4 / 1 443 855**

(73) Proprietor: **SpectraCure AB**  
**226 43 Lund (SE)**

(72) Inventors:  
• **Svanberg, Sune**  
**224 65 Lund (SE)**

• **Andersson-Engels, Stefan**  
**222 24 Lund (SE)**  
• **Svanberg, Katarina**  
**224 65 Lund (SE)**

(74) Representative: **KIPA**  
**Krahbichler Intellectual Property**  
**Advisors AB**  
**P.O. Box 1065**  
**251 10 Helsingborg (SE)**

(56) References cited:  
**EP-A- 0 429 297 WO-A-99/06113**  
**DE-U1- 9 112 188 GB-A- 2 126 717**

• **PATENT ABSTRACTS OF JAPAN vol. 012, no. 280**  
**(P-739), 2 August 1988 (1988-08-02) & JP 63**  
**060421 A (FUJIKURA LTD), 16 March 1988**  
**(1988-03-16)**

**EP 1 955 649 B1**

Note: Within nine months of the publication of the mention of the grant of the European patent in the European Patent Bulletin, any person may give notice to the European Patent Office of opposition to that patent, in accordance with the Implementing Regulations. Notice of opposition shall not be deemed to have been filed until the opposition fee has been paid. (Art. 99(1) European Patent Convention).

## Description

### BACKGROUND OF THE INVENTION

**[0001]** The invention relates to a system for interstitial photodynamic and photothermal tumor therapy and diagnosis of a tumor at a tumor site in a body, wherein radiation is conducted to the site for said therapy and diagnosis. The system comprises at least two primary radiation conductors at distal ends thereof interstitially inserted into a tumor and a diagnostic radiation source adapted to be activated and to transmit diagnostic radiation through at least one of said primary radiation conductors to the distal ends thereof for distribution through said tumor.

**[0002]** Within the field of medical therapy of tumor diseases, a plurality of treatment modalities has been developed for the treatment of malignant tumor diseases, e.g. a tumefaction. Operation, cytostatics treatment, treatment with ionising radiation (gamma or particle radiation), isotope therapy, and brachytherapy employing radioactive needles are examples of common treatment modalities. In spite of great progress within therapy, the tumor diseases continue to account for much human suffering, and are responsible for a high percentage of deaths in Western countries. A relatively new treatment modality, photodynamic therapy, commonly abbreviated PDT, provides an interesting complement or alternative in the treatment field. A tumorseeking agent, normally referred to as a sensitizer, is administered to the body intravenously, orally or topically. It accumulates in malignant tumors to a higher extent than in the surrounding healthy tissue. The tumor area is then irradiated with non-thermal red light, normally from a laser, leading to excitation of the sensitizer to a more energetic state. Through energy transfer from the activated sensitizer to the oxygen molecules of the tissue, the oxygen is transferred from its normal triplet state to the excited singlet state. Singlet oxygen is known to be particularly toxic to tissue; cells are eradicated and the tissue goes in necrosis. Because of the localization of the sensitizer to tumor cells a unique selectivity is obtained, where surrounding healthy tissue is spared. The initial clinical experience, using in particular haematoporphyrin derivative (HPD) and delta amino levulinic acid (ALA) are good.

**[0003]** Sensitizers also exhibit a further useful property; to yield a characteristic red fluorescence signal when the substance is excited with violet or ultraviolet radiation. This signal clearly appears in contrast to the autofluorescence of the tissue and can be used to localize tumors and for quantifying the size of the uptake of the sensitizer in the tissue.

**[0004]** The limited penetration in the tissue of the activating red radiation is a big drawback of PDT. The result is that only tumors up to about 5 mm thickness can be treated by surface irradiation. In order to treat thicker and deeplying tumors, interstitial PDT (IPDT) can be utilized. Here, light conducting optical fibers are brought into the

tumor using, e.g. a syringe needle, in the lumen of which a fiber has been placed.

**[0005]** In order to achieve an efficient treatment, several fibers have been used to ascertain that all tumor cells are subjected to a sufficient dose of light so that the toxic singlet state is obtained. It has been shown to be achievable to perform dose calculations of the absorptive and scattering properties of the tissue. E.g., in the Swedish patent SE 503 408 an IPDT system is described, where six fibers are used for treatment as well as for measurement of the light flux which reaches a given fiber in the penetration through the tissue from the other fibers. In this way an improved calculation of the correct light dose can be achieved for all parts of the tumor.

**[0006]** In the equipment described in SE 503 408 the light from a single laser is divided up in six different parts using a beamsplitter system comprising a large number of components. The light is then focused into each of the six individual treatment fibers. One fiber is used as a transmitter while the other fibers are used as receivers of radiation penetrating the tissue. For light measurement light detectors are swung into the beam path which thus is blocked, and the weak light, which originates from the fibers that collected the light which is administered to the tissue, is measured.

**[0007]** However, such open beam paths result in a strongly lossy beamsplitting and the resulting losses of light drastically impair the light distribution as well as the light measurement. Furthermore, such a system must often be adjusted optically, which is also an important consideration in connection with clinical treatments.

**[0008]** EP 0195375 discloses a catheter for laser angioplasty. A laser catheter is disclosed wherein optical fibers carrying laser light are mounted in a catheter for insertion into an artery to provide controlled delivery of a laser beam for percutaneous intravascular laser treatment of atherosclerotic disease. Multiple optical fibers in the catheter allow the selection of tissue that is to be removed. A computer controlled system automatically aligns fibers with the laser and controls exposure time. However, the system does not provide interstitial interactive treatment of tumours.

**[0009]** EP 0429297 discloses a diagnosis and treatment device comprises a solid-state laser generator, for emitting a first laser beam having a first wavelength, a harmonic generator for generating higher harmonic laser beams of the first laser beam and outputting one of the higher harmonic laser beams, and an optical parametric oscillator for converting the higher harmonic laser beam output from the harmonic generator into a second and third laser beams suitable for the cancer diagnosis and treatment. The apparatus also includes an endoscope for guiding the second and third laser beams emitted from the laser beam source to the cancer foci and for transmitting an image of the fluorescence of the photosensitive material to the outside of a body, and a cancer observing unit having a screen for receiving the image of the fluorescence of the photosensitive material transmitted

through the endoscope unit and displaying the image on the screen to thereby perform the cancer diagnosis. However, the system does not provide interstitial interactive treatment of tumours.

**[0010]** JP 04343317 discloses a switch for optical elements adapted for use in lighting devices or systems thereof, which switch may be operated by rotating two ferrules in respect of each other. To ensure correct positioning the device according to JP 04343317 needs positioning pins.

**[0011]** System fo since this device is in need of very exact positioning of the fibers to be connected. This way of operating such a switch demands rotational as well as translational movement. Switching is thus cumbersome and slow.

### SUMMARY OF THE INVENTION

**[0012]** In an embodiment, the invention according to claim 1 relates to, a system for interactive interstitial photodynamic tumor therapy and/or photothermal tumor therapy and/or tumor diagnosis is provided wherein at least one radiation sensor and radiation conductor is connected to a tumor site and the radiation conductor is used as a transmitter and/or a receiver for conduction of radiation to and/or from a tumor site for diagnosis and therapy of a tumor at the tumor site. The system is preferably adapted to automatically switch between tumor therapy and tumor diagnostics, whereby the results from the diagnostics control the therapy process by regulating a therapeutic radiation intensity depending on the results of the diagnostics.

**[0013]** In one embodiment, the invention comprises a system for interactive interstitial photodynamic and photothermal tumor therapy and tumor diagnosis, comprising at least one radiation source, at least one radiation sensor and a radiation conductor which are brought to a tumor site, wherein the radiation conductor is in use employed as a transmitter and/or a receiver for conduction of radiation to and/or from the tumor site for diagnosis and therapy of a tumor at the tumor site, said system comprising a distributor for distribution of radiation from at least one radiation source to the tumor site, and from the tumor site to at least one radiation sensor.

**[0014]** In some embodiments, the distributor comprises a plurality of first radiation conductors arranged for delivering radiation from the radiation source and/or conduction of radiation to the radiation sensor, two flat discs abutting against each other, wherein a first of said discs is fixed and the second of said discs is turnable relatively to the other disc, each disc has holes arranged on a circular line, wherein the circle radius on one disc equals the circle radius on the other disc and where the holes in one disc are equally distributed on the circle line with an angular separation of  $v_1 = (360/n_1)$  degrees,  $n_1$  being the number of holes, and the holes in the other disc are equally distributed on the circle line with an angular separation of  $v_2 = (360/n_2)$  degrees, wherein  $n_2 = m \times n_1$ , and

wherein  $m$  is a multiple, which yields  $n_2$  as an integer  $\geq 1$ . The first ends of the first radiation conductors are fixed in the holes of the fixed disc and first ends of the second radiation conductors are fixed in the holes of the turnable disc, whereby the first and the second radiation conductors by rotation of the turnable disc are connectable to each other in different constellations.

### BRIEF DESCRIPTION OF THE DRAWINGS

**[0015]** In order to more closely explain the invention a number of embodiments of the invention will be described in the following with reference to the figures, wherein

**[0016]** FIG. 1 is a schematic perspective view of a first embodiment of the system according to the invention, wherein light conductors arranged in said invention are interstitially inserted in a tumor,

**[0017]** FIG. 2 is a view similar to FIG. 1, where discs of a distributor are brought apart,

**[0018]** FIG. 3 is a planar view from above of the turnable distributor disc with holes arranged in said disc,

**[0019]** FIG. 4 is a fragmentary cross section view of the turnable disc of said distributor, wherein a spring-loaded ball is provided,

**[0020]** FIG. 5 is a schematic perspective view illustrating the use of the system according to an embodiment of the invention with the distributor in the mode of tumor diagnostics,

**[0021]** FIG. 6 is a view similar to FIG. 5 and FIG. 2, where two distributors are arranged on the same single axis, and

**[0022]** FIG. 7 is a schematic perspective view illustrating the use of the system according to an embodiment of the invention, with the distributor in the mode of photodynamic treatment of a tumor.

### DETAILED DESCRIPTION OF THE INVENTION

**[0023]** An embodiment of the distributor of the system according to the invention is now described with reference to FIG. 1. The distributor 1 comprises two flat and in proximity lying discs made of, e.g. 1 cm thick steel. The discs are hereby arranged on an axis 2, wherein one of the discs is a fixed disc 3 and the other one is a turnable disc 4. The discs 3 and 4 are abutting against each other in FIG. 1 and separated from each other in FIG. 2.

**[0024]** Evenly distributed holes 5 lying on a circle are arranged in both discs (FIG. 3) for fixation of primary radiation conductors 6 in one of the discs and secondary radiation conductors 7 in the other disc, respectively. Preferably the diameter of the holes is 0.3 - 0.7 mm. In order to attain a high precision, allowing the light conductors to be arranged exactly face to face, the holes of the two discs can be drilled together, maybe with a centering tube. Then the common axis 2 is utilized. It is thus possible to achieve a very high precision when making the series of holes.

**[0025]** By employing discs drilled together, radiation

conductors can be fixed in said discs, wherein an extra, thinner disc then can be turned slightly, preferably spring-loaded, so that all light conductors are simultaneously pinched in their positions without the need for any glue or other fixation means. Alternatively, the diameter of the holes is made larger than the diameter of the light conductors, wherein the holes can be dressed with an appropriate piece of tubing, or the ends of the light conductors can be supplied with a fitted hose. Alternatively, the ends of the light conductors can be flared or flanged into the holes.

**[0026]** Preferably the light conductors are optical fibers, wherein different types of hoses or flexible tubes containing a light conducting material are included. The light conductors should have such a length and be arranged in such a way that the turnable disc 4 can be turned without problems a full turn (360 degrees). The direction of movement can be reversed to avoid the light conductors forming a spiral.

**[0027]** According to an embodiment of the invention a plurality of primary light conductors 6 in a system are arranged in the fixed disc 3 for conduction of radiation to and from a reaction site 8. By a reaction site we in the present context mean a site where photodynamically active compounds will react in a tumor when subject to therapy. E.g., by being forwarded through the lumen of injection needles which are placed in the tumor, these primary radiation conductors 6 are then fixed in the reaction site 8. Then the primary radiation conductors are moved forward to arrive outside the distal end of the needle. The same light conductor 6 is used all the time for integrated diagnostics and dosimetry, to avoid that the patient be subjected to multiple pricks.

**[0028]** The holes 5 in the fixed disc 3 as well as in the turnable disc 4 are arranged on a circular line, wherein the circle radius on one disc equals the circle radius on the other disc. The holes on one disc are equally distributed along the circle line with an angular separation of

**[0029]**  $v_1 = (360/n_1)$  degrees, where  $n_1$  equals the number of holes, and the holes of the other disc are equally distributed along the circle line with an angular separation  $v_2$  equaling  $(360/n_2)$  degrees. The proximal ends of the primary radiation conductors 6 are fixed in the holes of the fixed disc 3, and distal ends of the secondary radiation conductors 7 are fixed in the holes of the turnable disc 4. In order to make the holes, and thereby the primary and secondary radiation conductors in both discs connectable to each other in different constellations by turning of the turnable disc 4,  $n_2$  is selected to be a multiple of  $n_1$ , in such a way that  $n_2$  is obtained as an integer larger or equal to 1. Suitably the number of holes in the fixed disc is chosen from two to more than six.

**[0030]** Preferably six holes are arranged in the fixed disc 3 and twelve holes are arranged in the turnable disc 4. With six primary radiation conductors 6 the angular separation will accordingly become 60 degrees in the fixed disc 3 and with twelve holes arranged in the turnable disc 4 the angular separation will become 30 degrees for

the secondary radiation conductors 7.

**[0031]** In order to facilitate the comprehension of the invention the following description of an embodiment of the distributor of a system according to an embodiment of the invention relates to six primary radiation conductors 6 arranged with their proximal ends in the fixed disc 3 for conduction of radiation to and from the reaction site 8 at the distal ends of the primary radiation conductors.

**[0032]** Thus, the turnable disc 4, as well as the fixed disc 3, have six holes 5 for corresponding six diagnostic secondary radiation conductors 7, and, in addition, six further holes for six therapeutic secondary radiation conductors 7. All these twelve radiation conductors 7 can release radiation to the reaction site 8 and receive radiation from said site. Thus, several spectra can be recorded and read out simultaneously.

**[0033]** By turning the turnable disc 4 the primary and the secondary radiation conductors become connectable to each other in different constellations. An exact positioning of the opposing radiation conductors in the distributor 1 is facilitated by arranging means for stopping the turnable disc 4 in predetermined angular positions. E.g., grooves 10 can be arranged in the axis 2 for catching a spring-loaded ball 11 arranged in the turnable disc 4 (FIG. 4).

**[0034]** In order to allow a fast and efficient switching between a diagnostic mode and a therapeutic mode, every other of the secondary light conductors of the distributor 1 according to an embodiment of the invention, are divided into a diagnostic and into a therapeutic series. Both series of holes are arranged on the same circle, but displaced by 30 degrees with regard to each other. A specific therapeutic light conductor 7a' in the diagnostic series of every other secondary light conductor is arranged for emitting radiation from at least one diagnostic radiation source 9a. The other, non specific diagnostic radiation conductors 7a in the diagnostic series of secondary radiation conductors are arranged for conduction of radiation to at least one diagnostic radiation sensor 12. The therapeutic series of every other secondary radiation conductor 7b is for therapeutical purposes arranged to emit radiation to the reaction site 8 from at least one therapeutic radiation source 9b.

**[0035]** In an embodiment of the invention, the primary and secondary radiation conductors are optical fibers, which in the distributor 1 shown in FIGS. 1 and 2 are connected to the fixed disc 3 as well as the turnable disc 4. Out of the fibers, which are connected to the turnable disc 4, six diagnostic fibers can be used for diagnostic purposes and six therapeutic fibres can be used of therapeutical purposes. However, in the diagnostic mode, from one to more than three modalities can be employed.

**[0036]** With reference to FIG. 5 - 7 only the presently described radiation conductors which are coupled to a turnable disc are for clarifying purposes shown; the other radiation conductors are not shown although they are coupled to said disc.

**[0037]** By turning the turnable disc 4 by 30 degrees

the primary fibers 6 which at their distal ends, respectively, are optically coupled to the tissue of the patient can be employed for therapy as well as diagnostics and measurements. One out of every diagnostic secondary radiation conductor 7 is in the diagnostic mode connected to different radiation sources for diagnostics, while the other five diagnostic radiation conductors receive signals, which are related to the interaction of these diagnostic radiation sources with the tissue.

**[0038]** Since intensity as well as spectral resolution is of interest, the distal ends of these five diagnostic radiation conductors are arranged in a slitlike arrangement so that they overlap the entrance slit and/or constitute the entrance slit of the radiation sensor 12, which is a compact spectrometer and is supplied with a two-dimensional detector array. The recording range of the spectrometer is preferably within the range 400 to 900 nm. Each of the diagnostic radiation conductors 7a can of course be connected to an individual radiation detector 12 in the form of a spectrometer or another type of detector, e.g. a compact integrated spectrometer.

**[0039]** With reference to FIG. 5 the specific diagnostic radiation conductor 7a' is connected to an arrangement similar to the distributor 1, which comprises a second fixed disc 13 and a second turnable disc 14 which are arranged on a common axis 15. All fixed and turnable discs can also be arranged on one single axis as is shown in FIG. 6. A more compact and robust construction is obtained in this way.

**[0040]** More specifically the diagnostic radiation conductor 7a' is proximally arranged in a single hole on the second fixed disc 13. Further diagnostic light conductors 17 are arranged on a circle in said second turnable disc 14; in this case three diagnostic light conductors which at their proximal end, respectively, are connected to different radiation sources 9a, and which each are connectable to the diagnostic radiation conductor 7a' and further on to a primary radiation conductor 6' comprised in the different primary radiation conductors 6 (See Fig. 5).

**[0041]** Preferably the diagnostic radiation source 9a is a laser of the same wavelength as the one utilized for the laser irradiation for photodynamic tumor therapy, but of substantially lower output power. Suitable filters can be arranged on the second turnable disc 14, to be turned into the light path of the diagnostic radiation sensor 12 in order to secure that the correct dynamic range is utilized for all measurement tasks.

**[0042]** Certain of the diagnostic radiation sources 9a are utilized in order to study how radiation (light) of the corresponding wavelength is penetrating through the tissue of the tumor. When light from a diagnostic radiation source 9a is transmitted through the particular diagnostic radiation conductors 17, 7a', 6' via the discs 14, 13, 4, 3, respectively, into the tissue 8, one of the primary radiation conductors 6, which is the radiation conductor 6' opposing the diagnostic radiation conductor 7a' in the distributor 1, will function as a transmitter into the tumor 8, and the other five primary radiation conductors 6 having their

distal ends arranged in the tumor 8 will act as receivers and collect the diffuse flux of light reaching them. The light collected is again conducted via the discs 3, 4, and diagnostic radiation conductors 7a to the radiation sensor 12 and five different light intensities can be recorded on the detector array.

**[0043]** When the turnable disc 4 is turned by 60 degrees, the next primary radiation conductor 6 to the patient will get the role as transmitter, and the five others become the receivers for a new light distribution. After four further turns of the turnable disc 4, each by 60 degrees to the following primary radiation conductor 6 in the patient, light flux data for all remaining combinations of transmitters/receivers have been recorded. Thus, in total  $6 \cdot 5 = 30$  measurement values are obtained and can be used as input data for a tomographic modelling of the optical dose build up in the different parts of the tumor during the course of the treatment.

**[0044]** As an alternative to a specific wavelength, radiation from a white light source can be coupled into the particular diagnostic light conductor 7a' and into the tissue from the distal end of primary radiation conductor 6'. From the distal end of primary radiation conductor 6', on passage through the tissue to the distal end of the receiving light conductor 6 in the patient, the well-defined spectral distribution of the diagnostic radiation source 9a will be modified by the tissue absorption. Then, oxygenated blood yields a different signature than non-oxygenated blood, allowing a tomographic determination of the oxygen distribution utilizing the thirty different spectral distributions which are read out, five spectra at a time in the six possible different constellations on rotation of the turnable disc 4 during a diagnostic investigation. Such a determination of the oxygenation in the tumor is important, since the PDT process requires access to oxygen in the tissue.

**[0045]** Finally, a light source for blue/violet or ultraviolet light, e.g. a laser, can be coupled to the particular radiation conductor 7a'. Then fluorescence is induced in the tissue, and a sensitizer administered to the tissue displays a characteristic red fluorescence distribution in the red/nearinfrared spectral region. The strength of the corresponding signal allows a quantification of the concentration of the sensitizer in the tissue.

**[0046]** Since the short wavelength light has a very low penetration into the tissue, the induced fluorescence must be measured locally at the tip of the distal end of the primary radiation conductor. For this task there is in this case for the corresponding radiation source 9a at the proximal end of the particular diagnostic radiation conductor 17 a beamsplitter 18, which is preferably dichroitic, transmitting the exciting light but reflecting the redshifted fluorescence light. This reflected light is focused into the proximal end of a conveying radiation conductor 19, the distal end of which is connected to the radiation sensor 12, which records the fluorescence light distribution. A suitable self-contained fluorosensor is described in Rev. Sci. Instr. 71, 3004 (2000).

[0047] By rotating the turnable disc 4, the fluorescence which is proportional to the concentration of the sensitizer, can be measured sequentially at the tips at the distal ends of the six primary radiation conductors. Since the sensitizer is bleached by the strong red treatment light, being particularly strong just around the tip of the primary radiation conductor 6', it is essential to make this measurement before the start of the treatment.

[0048] If the tips of the primary radiation conductors 6 in addition are treated with a material, the fluorescence properties of which are temperature dependent, sharp fluorescence lines are obtained upon excitation, and the intensity of the lines and their relative strength depend on the temperature of the tip of the radiation conductor 6'. Examples of such materials are salts of the transition metals or the rare earth metals. Thus also the temperature can be measured at the six positions of the six radiation conductors, one at a time. The measured temperatures can be utilized to find out if blood coagulation with an associated light attenuation has occurred at the tip of the radiation conductor 6 and for studies regarding the utilization of possible synergy effects between PDT and thermal interaction. Since the lines obtained are sharp, they can be lifted off the more broadbanded fluorescence distribution from the tissue.

[0049] The concentration of the sensitizer can for certain substances be measured in an alternative way. Then the red light used for the light propagation studies is used to induce nearinfrared fluorescence. This fluorescence penetrates through the tissue to the tips of the receiving primary radiation conductors 6, and are displayed simultaneously as spectra obtained in the radiation sensor 12. A tomographic calculation of the concentration distribution can be performed based on in total thirty measurement values.

[0050] After diagnostic measurements and calculations have been performed, the primary fibers 6 optically coupled to the tissue of the patient can be utilized for therapy by rotation of the turnable disc 4 by 30 degrees. Referring to FIG. 7, the therapeutic radiation conductors 7b of every other secondary radiation conductor 7 is utilized, now connected to the opposing radiation conductors 6 via the distributor 1. Each or the six therapeutic radiation conductors 7b is connected to an individual therapeutic radiation source 9b, which preferably is a laser source with a wavelength which is adapted to the absorption band of the sensitizer. At the photodynamic tumor treatment a dye laser or a diode laser is preferably used, with a wavelength which is selected with regard to the sensitizer employed. For Photofrin(R) the wavelength is 630 nm, for  $\delta$  amino levulinic acid (ALA) it is 635 and for phthalocyanines it is around 670 nm. The individual lasers are regulated during the treatment to a desirable individual output power. If desired, they may have built-in monitoring detectors.

[0051] The therapeutical treatment can be interrupted and new diagnostic data can be processed in an interactive way till an optimal treatment has been reached.

This method can include synergy between PDT and hyperthermia, where an increased temperature is reached at increased fluxes of laser radiation. The whole process is controlled using a computer, which does not only perform all the calculations but also is utilized for regulation.

## Claims

1. A system for interactive interstitial photodynamic and/or photothermal tissue therapy and diagnosis, said system comprising
  - at least two primary radiation conductors at distal ends thereof interstitially insertable into a tumor;
  - a diagnostic radiation source adapted to be activated and transmit diagnostic radiation through at least one of said primary radiation conductors to the distal ends thereof, such that said diagnostic radiation is transmittable through tissue at said tumor site to distal ends of the remaining primary radiation conductors interstitially insertable into said tumor;
  - a unit for collecting and evaluating diagnostic information from radiation received from said tissue;
  - a switching unit adapted to automatically switch between tissue therapy and tissue diagnostics;
  - characterized by** a unit adapted to control said tumor therapy by regulating a therapeutical radiation intensity depending on said diagnostic information; and
  - wherein said system is arranged to provide measurement values as input data for a tomographic modeling of an optical dose build up in different parts of the tumor during the course of treatment.
2. The system according to claim 1, wherein said at least two primary radiation conductors at distal ends thereof interstitially insertable into said tumor are placeable via injection needles having a lumen in the tumor, wherein each of said primary radiation conductors is forward through the lumen of said injection needle to arrive outside the distal end of the needle, respectively, whereby these primary radiation conductors are fixatable in said tumor.
3. The system according to claim 1 or 2, wherein the same primary radiation conductors are adapted, during treatment, for integrated diagnostics and dosimetry.
4. The system according to claim 1, comprising a turnable disc in an optical distributor arranged for switching between tumor diagnostics and tumor therapy by rotating said turnable disc in an optical distributor, such that different arrangements of diagnostic and therapeutic radiation conductors are connected to the primary radiation conductors.

5. The system according to any of claims 1 to 4, wherein said system is adapted to alternately switch between interactive interstitial photodynamic tumor therapy, photothermal tumor therapy using hyperthermia, and tumor diagnostics during the same occasion of treatment of said tumor site.
6. The system for interactive interstitial photodynamic and photothermal tumor therapy and diagnosis according to any of claims 1 to 5, said system comprising  
 at least one therapeutic radiation source and at least one diagnostic radiation source,  
 at least one diagnostic radiation sensor, and at least two primary radiation conductors which at their distal ends are interstitially arrangeable in a tumor site, wherein the primary radiation conductors are employable as a transmitter for diagnostic radiation from said diagnostic radiation source for diagnosis of a tumor at said tumor site, or for therapeutic radiation from said therapeutic radiation source for therapy of the tumor, respectively, or as a receiver for conduction of radiation from the tumor site for diagnosis of the tumor,  
 wherein said switching unit is a distributor for distribution of radiation from the diagnostic and therapeutic radiation source to the tumor site, and from the tumor site to at least one diagnostic radiation sensor, and  
 a plurality of secondary radiation conductors arranged for delivering radiation from the diagnostic or therapeutic radiation source or conduction of radiation to the diagnostic radiation sensor.
7. The system according to claim 6, wherein the distributor comprises  
 a plurality of primary radiation conductors arranged for conducting radiation to and from the tumor site, two flat discs abutting against each other, wherein a first of said discs is fixed and the second of said discs is turnable relatively to the other disc,  
 each disc having holes arranged on a circular line, wherein the proximal ends of the primary radiation conductors are fixed in the holes of the first disc and distal ends of the secondary radiation conductors are fixed in the holes of the second disc, whereby the primary and the secondary radiation conductors by rotation of the two discs relative another are connectable to each other in different constellations.
8. The system according to claim 7, wherein the circle radius of said circle line on one disc equals the circle radius on the other disc and where the holes in one disc are equally distributed on the circle line with an angular separation of  $v_1 = (360/n_1)$  degrees,  $n_1$  being the number of holes, and the holes in the other disc are equally distributed on the circle line with an angular separation of  $v_2 = (360/n_2)$  degrees, wherein  
 $n_2 = m \times n_1$ , and wherein  $m$  is a multiple, which yields  $n_2$  as an integer  $\geq 1$ .
9. The system according to any of claims 6 to 8, wherein every other secondary radiation conductor is part of a series of diagnostic radiation conductors and that a diagnostic radiation conductor in said series of diagnostic radiation conductors is arranged for emitting diagnostic radiation from the diagnostic radiation source and the other diagnostic radiation conductors in said series of diagnostic radiation conductors are arranged for conduction of radiation to the diagnostic radiation sensor.
10. The system according to any of claims 1 to 9, wherein the primary radiation conductors distal ends are treated by a material with temperature sensitive fluorescence emission.
11. The system according to claim 9, wherein the diagnostic radiation sensor comprises a spectrometer with a two-dimensional detector array and the proximal ends of said other diagnostic radiation conductors of said series of diagnostic radiation conductors are arranged in the entrance slit of the spectrometer.
12. The system according to claim 6, wherein every other secondary radiation conductor is part of a series of therapeutic radiation conductors arranged for emission of therapeutic radiation from the therapeutic radiation source; or  
 wherein the therapeutic radiation source comprises a light source for coherent light of a single fixed wavelength.
13. The system according to claim 10, wherein the therapeutic radiation which in use is sent to the tumor site is configured to heat the tumor site, and wherein the intensity of the therapeutic radiation is controllable by a measured temperature in order to regulate the temperature of the tumor site at the individual primary radiation conductors.
14. The system according to any preceding claim, wherein said system is adapted to provide a tomographic determination of an oxygen distribution in said tumor from a plurality of subsequently read spectral distributions in different constellations of said switching unit; and/or  
 wherein said system is adapted to provide a tomographic determination of a photosensitizer agent concentration distribution in said tumor from a plurality of subsequently read spectral distributions in different constellations of said switching unit.

## Patentansprüche

1. System zur interaktiven interstitiellen photodynamischen und/oder photothermischen Gewebetherapie und -diagnose, wobei das System Folgendes umfasst:
- 5
- mindestens zwei primäre Strahlungsleiter an dessen distalen Enden, welche interstitiell in einen Tumor eingeführt werden können;
- 10
- diagnostische Strahlungsquelle, die so beschaffen ist, dass sie aktivierbar ist und durch mindestens einen der primären Strahlungsleiter diagnostische Strahlung zu dessen distalen Enden hin übertragen kann, wodurch die diagnostische Strahlung durch das an der Tumorstelle befindliche Gewebe zu den distalen Enden der übrigen primären Strahlungsleiter übertragen werden kann, welche interstitiell in den Tumor einführbar sind;
- 15
- charakterisiert durch eine Einheit zum Sammeln und Bewerten von diagnostischen Informationen anhand der aus dem Gewebe empfangenen Strahlung;
- 20
- Schalteinheit, die so beschaffen ist, dass sie automatisch zwischen Gewebetherapie und Gewebediagnostik umschalten kann;
- 25
- charakterisiert durch eine Einheit, die so beschaffen ist, dass sie die Tumortherapie durch die Regulierung der Intensität der therapeutischen Strahlung in Abhängigkeit von den diagnostischen Informationen kontrolliert; und
- 30
- wobei dieses System so beschaffen ist, dass es Messwerte als Eingabedaten für eine tomographische Modellierung einer optischen Dosis liefert, welche während der Behandlungsdauer in verschiedenen Teilen des Tumors aufgebaut wird.
- 35
2. System gemäß Anspruch 1, wobei die mindestens zwei primären Strahlungsleiter, welche sich an dessen distalen Enden befinden und interstitiell in einen Tumor eingeführt werden können,
- 40
- sich mittels Injektionsnadeln, welche ein Lumen in dem Tumor haben, innerhalb des Tumors platzieren lassen, wobei jeder der primären Strahlungsleiter durch das Lumen der Injektionsnadel hindurch befördert wird, so dass er jeweils außerhalb des distalen Endes der Nadel ankommt, wobei sich diese primären Strahlungsleiter in dem Tumor fixieren lassen.
- 45
3. System gemäß Anspruch 1 oder 2, wobei dieselben primären Strahlungsleiter so angepasst sind, dass sie während der Behandlung eine integrierte Diagnostik und Dosimetrie ermöglichen.
- 50
4. System gemäß Anspruch 1, wobei es eine in einem
- optischen Verteiler befindliche drehbare Scheibe umfasst, so dass es derart beschaffen ist, dass durch das Drehen der drehbaren Scheibe in einem optischen Verteiler ein Umschalten zwischen Tumordiagnostik und Tumortherapie ermöglicht wird, wodurch es zu unterschiedlichen Verbindungen zwischen den Anordnungen der diagnostischen und therapeutischen Strahlungsleiter mit den primären Strahlungsleitern kommt.
5. System gemäß einem beliebigen der Ansprüche 1 bis 4, wobei das System so beschaffen ist, dass es während derselben Behandlungssitzung der Tumorstelle ermöglicht, zwischen interaktiver interstitieller photodynamischer Tumortherapie, photothermischer Tumortherapie unter Verwendung von Hyperthermie, und Tumordiagnostik hin- und herzuschalten.
6. System zur interaktiven interstitiellen photodynamischen und photothermischen Tumortherapie und -diagnose gemäß einem beliebigen der Ansprüche 1 bis 5, wobei das System umfasst:
- 25
- mindestens eine therapeutische Strahlungsquelle sowie mindestens eine diagnostische Strahlungsquelle,
- mindestens einen diagnostischen Strahlungssensor sowie mindestens zwei primäre Strahlungsleiter, die an ihren distalen Enden interstitiell an einer Tumorstelle angeordnet werden können,
- wobei die primären Strahlungsleiter jeweils als Sender für diagnostische Strahlung von der diagnostischen Strahlungsquelle zum Zwecke der Diagnose eines Tumors an der Tumorstelle, oder für therapeutische Strahlung von der therapeutischen Strahlungsquelle zum Zwecke der Therapie des Tumors, oder aber als Empfänger zur Leitung einer von der Tumorstelle kommenden Strahlung zum Zwecke der Diagnose des Tumors verwendet werden können,
- wobei die Schalteinheit einen Verteiler darstellt, welcher der Verteilung der Strahlung von der diagnostischen und therapeutischen Strahlungsquelle zur Tumorstelle, und von der Tumorstelle zu mindestens einem diagnostischen Strahlungssensor dient, und
- eine Vielzahl von sekundären Strahlungsleitern, die so angeordnet sind, dass sie Strahlung von der diagnostischen oder therapeutischen Strahlungsquelle liefern oder Strahlung an den diagnostischen Strahlungssensor leiten.
7. System gemäß Anspruch 6, wobei der Verteiler Folgendes umfasst:
- Vielzahl von primären Strahlungsleitern, die so

- angeordnet sind, dass sie Strahlung von der Tumorstelle weg sowie zur Tumorstelle hin leiten, zwei flache, aneinanderliegende Scheiben, von denen die erste befestigt und die zweite in Bezug auf die erste Scheibe drehbar ist, wobei jede Scheibe Öffnungen aufweist, die in einer kreisförmigen Linie angeordnet sind, wobei die proximalen Enden der primären Strahlungsleiter in den Öffnungen der ersten Scheibe und die distalen Enden der sekundären Strahlungsleiter in den Öffnungen der zweiten Scheibe befestigt sind, wodurch die primären und sekundären Strahlungsleiter durch die Drehung der zwei Scheiben in Bezug zueinander in verschiedenen Konstellationen miteinander verbunden werden können.
8. System gemäß Anspruch 7, wobei der Kreisradius der kreisförmigen Linie auf einer Scheibe dem Kreisradius auf der anderen Scheibe entspricht, und wobei die Öffnungen in einer Scheibe mit einem Winkelabstand von  $v_1 = (360/n_1)$  Grad gleichmäßig auf der Kreislinie verteilt sind, wobei  $n_1$  der Anzahl der Öffnungen entspricht, und die Öffnungen in der anderen Scheibe mit einem Winkelabstand von  $v_2 = (360/n_2)$  Grad gleichmäßig auf der kreisförmigen Linie verteilt sind, wobei  $n_2 = m \times n_1$  gilt, und wobei  $m$  ein Vielfaches darstellt, aus welchem sich  $n_2$  als eine Ganzzahl  $\geq 1$  ergibt.
9. System gemäß einem beliebigen der Ansprüche 6 bis 8, wobei jeder andere sekundäre Strahlungsleiter einen Teil einer Serie von diagnostischen Strahlungsleitern bildet, und wobei ein diagnostischer Strahlungsleiter in dieser Serie von diagnostischen Strahlungsleitern so beschaffen ist, dass er diagnostische Strahlung von der diagnostischen Strahlungsquelle aussendet, und wobei die übrigen diagnostischen Strahlungsleiter in dieser Serie von diagnostischen Strahlungsleitern so beschaffen sind, dass sie die Leitung der Strahlung zu dem diagnostischen Strahlungssensor hin ermöglichen.
10. System gemäß einem der Ansprüche 1 bis 9, wobei die distalen Enden der primären Strahlungsleiter mit einem Material behandelt sind, das sich durch temperaturabhängige Fluoreszenzemission auszeichnet.
11. System gemäß Anspruch 9, wobei der diagnostische Strahlungssensor ein Spektrometer mit einer zweidimensionalen Detektoranordnung umfasst, und die proximalen Enden der übrigen zu der Serie von diagnostischen Strahlungsleitern gehörenden diagnostischen Strahlungsleiter in dem Eingangsspalt des Spektrometers angeordnet sind.
12. System gemäß Anspruch 6, wobei jeder übrige sekundäre Strahlungsleiter einen Teil einer Serie von therapeutischen Strahlungsleitern bildet, die so beschaffen sind, dass sie die Aussendung von therapeutischer Strahlung aus der therapeutischen Strahlungsquelle ermöglichen; oder wobei die therapeutische Strahlungsquelle eine Lichtquelle für kohärentes Licht einer einzigen festgesetzten Wellenlänge umfasst.
13. System gemäß Anspruch 10, wobei die therapeutische Strahlung, die bei Gebrauch zu der Tumorstelle hin ausgesendet wird, so konfiguriert ist, dass sie die Tumorstelle erwärmt, wobei sich die Intensität der therapeutischen Strahlung basierend auf einer gemessenen Temperatur kontrollieren lässt, so dass die Temperatur der Tumorstelle an den einzelnen primären Strahlungsleitern reguliert werden kann.
14. System gemäß einem beliebigen der vorangegangenen Ansprüche, wobei das System so angepasst ist, dass es anhand einer Vielzahl von aufeinanderfolgend abgelesenen spektralen Verteilungen bei verschiedenen Konstellationen der Schalteinheit eine tomographische Bestimmung einer Sauerstoffverteilung in dem Tumor liefert; und/oder wobei das System so angepasst ist, dass es eine tomographische Bestimmung der Konzentrationsverteilung eines Photosensibilisatorwirkstoffes in dem Tumor anhand einer Vielzahl von aufeinanderfolgend abgelesenen Spektralverteilungen bei verschiedenen Konstellationen der Schalteinheit liefert.

#### Revendications

1. Système destiné à la thérapie de tissus photodynamique interstitielle interactive et/ou à la thérapie de tissus photothermique et au diagnostic de tissus, ledit système comprenant
- au moins deux conducteurs de rayonnement principaux aux extrémités distales de celui-ci, pouvant être insérés interstitiellement dans une tumeur ;
  - une source de rayonnement de diagnostic adaptée pour être activée et transmettre un rayonnement de diagnostic via au moins un desdits conducteurs de rayonnement principaux vers les extrémités distales de celui-ci, de telle sorte que ledit rayonnement de diagnostic est transmissible via un tissu au niveau dudit site tumoral aux extrémités distales des conducteurs de rayonnement principaux restants, pouvant être insérés interstitiellement dans ladite tumeur ;
  - une unité destinée à collecter et à évaluer des informations de diagnostic à partir d'un rayonnement reçu desdits tissus ;
  - une unité de commutation adaptée pour commuter automatiquement entre thérapie de tissus et diagnostic de tissus ;

- caractérisé par** une unité adaptée au contrôle de ladite thérapie de tumeur en régulant une intensité de rayonnement thérapeutique en fonction desdites informations de diagnostic ; et où ledit système est agencé pour fournir des valeurs de mesures comme données d'entrée à une modélisation tomographique d'une dose optique accumulée dans différentes parties de la tumeur pendant le déroulement du traitement.
2. Système selon la revendication 1, dans lequel lesdits au moins deux conducteurs de rayonnement principaux aux extrémités distales de celui-ci pouvant être insérés interstitiellement dans ladite tumeur peuvent être placés via des aiguilles d'injection ayant une lumière dans la tumeur, dans lequel chacun desdits conducteurs de rayonnement principaux est avancé à travers la lumière de ladite aiguille d'injection pour arriver en dehors de l'extrémité distale de l'aiguille, respectivement, grâce à quoi ces conducteurs de rayonnement principaux peuvent être fixés dans ladite tumeur.
  3. Système selon la revendication 1 ou 2, dans lequel les mêmes conducteurs de rayonnement principaux sont adaptés, pendant le traitement, au diagnostic intégré et à la dosimétrie.
  4. Système selon la revendication 1, comprenant un disque rotatif dans un distributeur optique agencé pour commuter entre diagnostic de tumeur et thérapie de tumeur en faisant tourner ledit disque rotatif dans un distributeur optique, de telle sorte que lesdits différents agencements des conducteurs de rayonnement de diagnostic et thérapeutique sont connectés aux conducteurs de rayonnement principaux.
  5. Système selon l'une quelconque des revendications 1 à 4, dans lequel ledit système est adapté pour commuter alternativement entre thérapie de tumeur photodynamique interstitielle interactive, thérapie de tumeur photothermique utilisant l'hyperthermie, et diagnostic de tumeur pendant la même occasion de traitement dudit site tumoral.
  6. Système destiné à la thérapie de tissus photodynamique interstitielle interactive, à la thérapie de tissus photothermique et au diagnostic de tissus selon l'une quelconque des revendications 1 à 5, ledit système comprenant
    - au moins une source de rayonnement thérapeutique et au moins une source de rayonnement de diagnostic,
    - au moins un capteur de rayonnement de diagnostic, et au moins deux conducteurs de rayonnement principaux qui, à leurs extrémités distales, peuvent être agencés interstitiellement dans un site tumoral, dans lequel les conducteurs de rayonnement principaux peuvent être utilisés comme transmetteur de rayonnement de diagnostic depuis ladite source de rayonnement de diagnostic pour le diagnostic d'un tumeur sur ledit site tumoral, ou de rayonnement thérapeutique depuis ladite source de rayonnement thérapeutique pour une thérapie de la tumeur, respectivement, ou comme récepteur pour la conduction de rayonnement depuis le site tumoral pour diagnostic de la tumeur,
    - dans lequel ladite unité de commutation est un distributeur pour la distribution des rayonnements depuis la source de rayonnement de diagnostic et thérapeutique vers le site tumoral, et depuis le site tumoral vers au moins un capteur de rayonnement de diagnostic, et
    - une pluralité de conducteurs de rayonnement secondaires agencés pour délivrer le rayonnement depuis la source de rayonnement de diagnostic ou thérapeutique ou pour conduire le rayonnement vers le capteur de rayonnement de diagnostic.
  7. Système selon la revendication 6, dans lequel le distributeur comprend
    - une pluralité de conducteurs de rayonnement principaux agencés pour conduire le rayonnement vers et depuis le site tumoral,
    - deux disques plats s'appuyant l'un sur l'autre, où un premier desdits disques est fixe et le second desdits disques peut tourner par rapport à l'autre disque, chaque disque comportant des trous ménagés sur une ligne circulaire,
    - dans lequel les extrémités proximales des conducteurs de rayonnement principaux sont fixées dans les trous du premier disque et les extrémités distales des conducteurs de rayonnement secondaires sont fixées dans les trous du second disque, grâce à quoi, par rotation des deux disques l'un par rapport à l'autre, les conducteurs de rayonnement principaux et secondaires peuvent être raccordés les uns aux autres dans différentes constellations.
  8. Système selon la revendication 7, dans lequel le rayon du cercle de ladite ligne circulaire sur un disque est égal au rayon du cercle sur l'autre disque et où les trous dans un premier disque sont répartis de manière égale sur la ligne circulaire avec une séparation angulaire de  $v1=(360/n1)$  degrés,  $n1$  étant le nombre de trous, et les trous dans l'autre disque sont répartis de manière égale sur la ligne circulaire avec une séparation angulaire de  $v2=(360/n2)$  degrés, où  $n2=m \times n1$ , et où  $m$  est un multiple, qui donne  $n2$  en tant qu'entier  $\geq 1$ .
  9. Système selon l'une quelconque des revendications 6 à 8, dans lequel un conducteur de rayonnement secondaire sur deux fait partie d'une série de conducteurs de rayonnement de diagnostic et dans le-

- quel un conducteur de rayonnement de diagnostic dans ladite série de conducteurs de rayonnement de diagnostic est agencé pour émettre un rayonnement de diagnostic depuis la source de rayonnement de diagnostic et les autres conducteurs de rayonnement de diagnostic sont agencés pour conduire un rayonnement vers le capteur de rayonnement de diagnostic.
- 5
- 10
10. Système selon l'une quelconque des revendications 1 à 9, dans lequel les extrémités distales des conducteurs de rayonnement principaux sont traitées par un matériau ayant une émission de fluorescence sensible à la température.
- 15
11. Système selon la revendication 9, dans lequel le capteur de rayonnement de diagnostic comprend un spectromètre ayant un agencement de détecteur bidimensionnel et les extrémités proximales desdits autres conducteurs de rayonnement de diagnostic de ladite série de conducteurs de rayonnement de diagnostic sont agencées dans la fente d'entrée du spectromètre.
- 20
- 25
12. Système selon la revendication 6, dans lequel un conducteur de rayonnement secondaire sur deux fait partie d'une série de conducteurs de rayonnement thérapeutique agencés pour l'émission de rayonnement thérapeutique depuis la source de rayonnement thérapeutique ; ou dans lequel la source de rayonnement thérapeutique comprend une source de lumière pour la lumière cohérente d'une seule longueur d'onde fixe.
- 30
- 35
13. Système selon la revendication 10, dans lequel le rayonnement thérapeutique qui, en cours d'utilisation, est envoyé vers le site tumoral est configuré pour chauffer le site tumoral, et dans lequel l'intensité du rayonnement thérapeutique peut être contrôlée par une température mesurée afin de réguler la température du site tumoral au niveau des conducteurs de rayonnement principaux individuels.
- 40
- 45
14. Système selon l'une quelconque des revendications précédentes, dans lequel ledit système est adapté pour fournir une détermination tomographique d'une distribution d'oxygène dans ladite tumeur à partir d'une pluralité de distributions spectrales lues par la suite dans différentes constellations de ladite unité de commutation ; et/ou où ledit système est adapté pour fournir une détermination tomographique d'une distribution de concentration d'agent photosensibilisateur dans ladite tumeur à partir d'une pluralité de distributions spectrales lues par la suite dans différentes constellations de ladite unité de commutation.
- 50
- 55

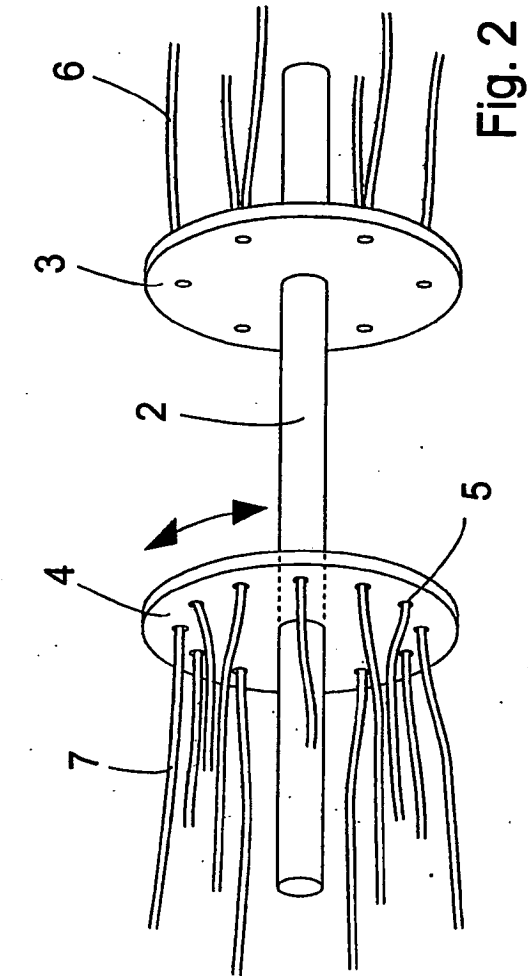

Fig. 2

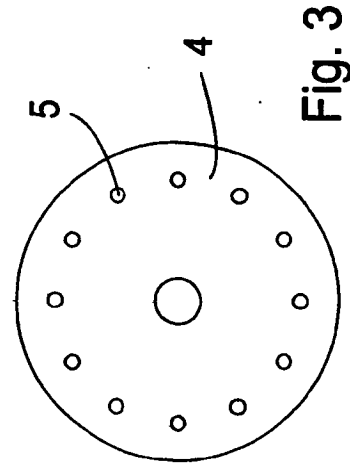

Fig. 3

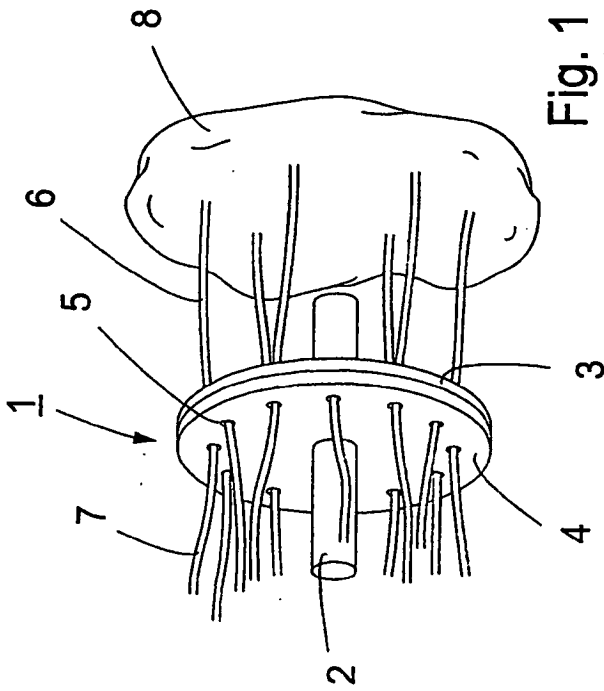

Fig. 1

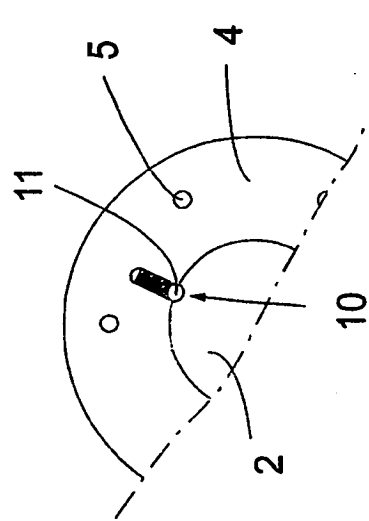

Fig. 4

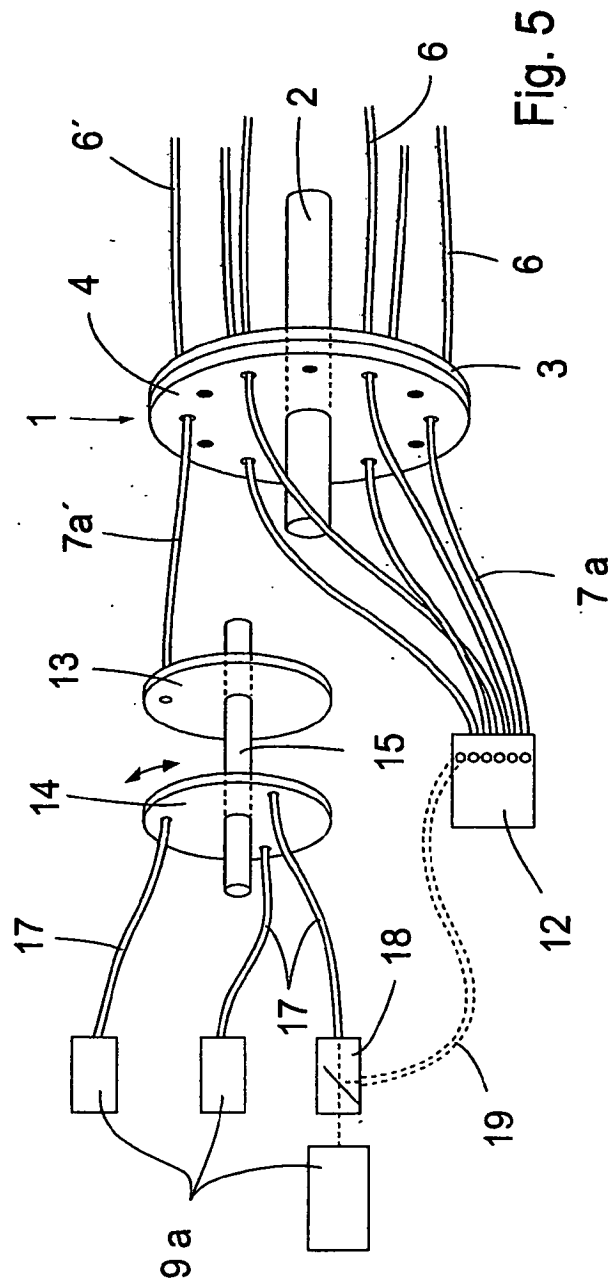
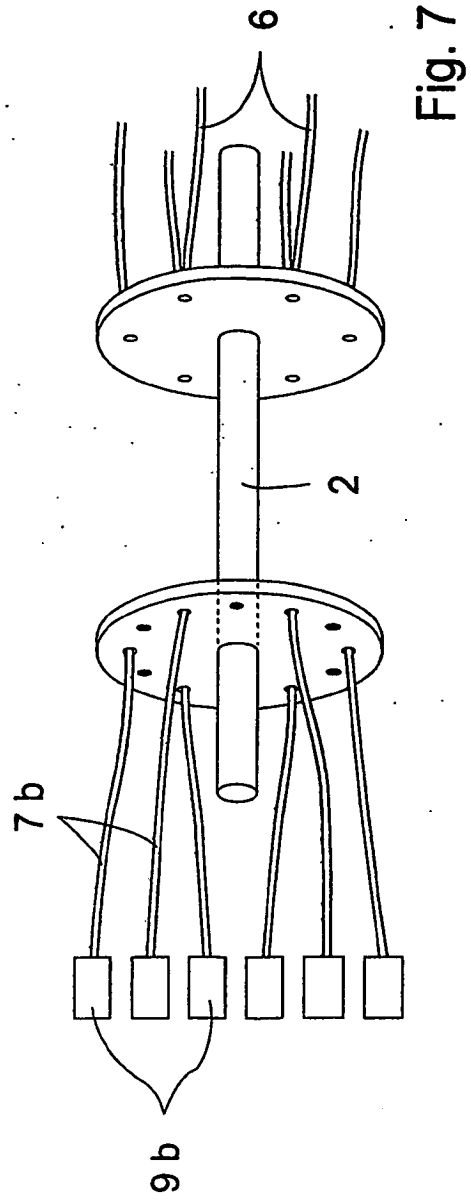
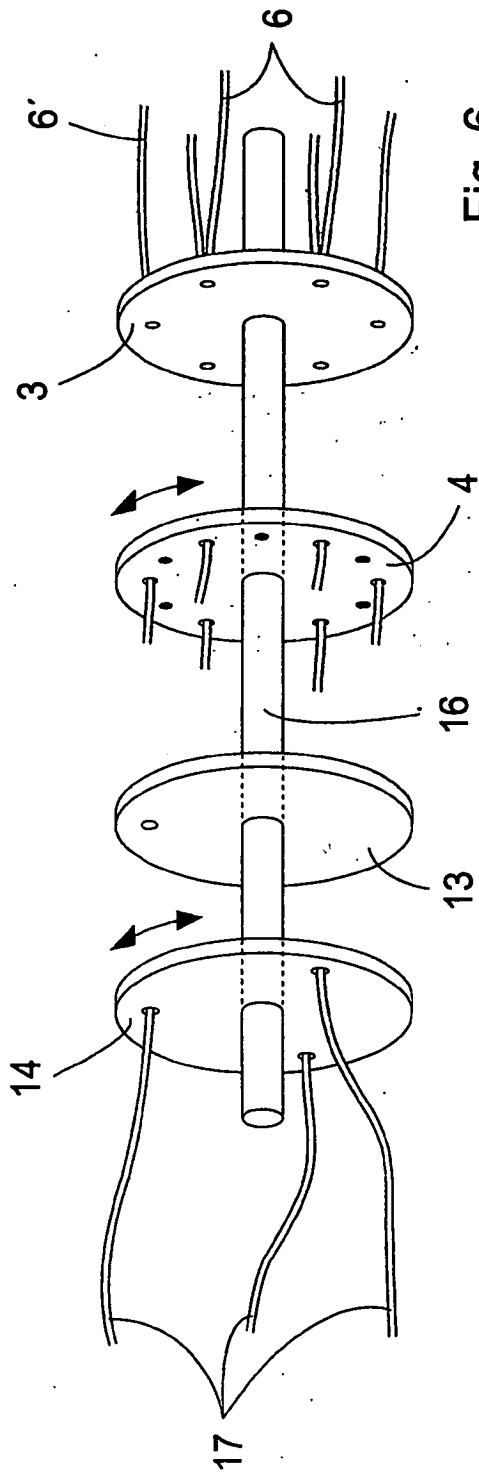

Fig. 5



**REFERENCES CITED IN THE DESCRIPTION**

*This list of references cited by the applicant is for the reader's convenience only. It does not form part of the European patent document. Even though great care has been taken in compiling the references, errors or omissions cannot be excluded and the EPO disclaims all liability in this regard.*

**Patent documents cited in the description**

- SE 503408 [0005] [0006]
- EP 0195375 A [0008]
- EP 0429297 A [0009]
- JP 04343317 B [0010]

**Non-patent literature cited in the description**

- *Rev. Sci. Instr.*, 2000, vol. 71, 3004 [0046]

专利名称(译)	用于交互式间质光动力学和光电化学肿瘤治疗和诊断的系统		
公开(公告)号	<a href="#">EP1955649B1</a>	公开(公告)日	2011-12-28
申请号	EP2008102902	申请日	2002-11-11
申请(专利权)人(译)	SPECTRACURE AB		
当前申请(专利权)人(译)	SPECTRACURE AB		
[标]发明人	SVANBERG SUNE ANDERSSON ENGELS STEFAN SVANBERG KATARINA		
发明人	SVANBERG, SUNE ANDERSSON-ENGELS, STEFAN SVANBERG, KATARINA		
IPC分类号	A61B5/00 A61B5/22 A61N5/06 G02B26/08 G02B6/36 A61B10/00		
CPC分类号	A61N5/062 A61B5/1455 A61N5/0601 A61N2005/0612 A61N2005/063 G02B6/3504 G02B6/3556 G02B6/4298		
代理机构(译)	KIPA		
优先权	0103771 2001-11-14 SE		
其他公开文献	EP1955649A1		
外部链接	<a href="#">Espacenet</a>		

摘要(译)

公开了一种用于交互式间质光动力学和光热肿瘤治疗和诊断的系统。该系统包括在其远端的至少两个初级辐射导体，其间隙地插入肿瘤中；诊断辐射源，适于被激活并且通过至少一个所述初级辐射导体将诊断辐射传输到其远端，使得所述诊断辐射通过所述肿瘤部位处的组织传输到剩余的初级辐射导体的远端。间质插入所述肿瘤；用于收集和评估从所述肿瘤接收的辐射的诊断信息的单元；切换单元，适于在肿瘤治疗和肿瘤诊断之间自动切换；和适于通过根据所述诊断信息调节治疗辐射强度来控制所述肿瘤治疗的单元。

