

(19)



(11)

EP 1 729 629 B1

(12)

EUROPEAN PATENT SPECIFICATION

(45) Date of publication and mention of the grant of the patent:
11.11.2009 Bulletin 2009/46

(51) Int Cl.:
A61B 5/00^(2006.01) A61B 5/103^(2006.01)
G01N 21/47^(2006.01) G06T 5/50^(2006.01)
G06T 5/00^(2006.01)

(21) Application number: **05710889.6**

(86) International application number:
PCT/NL2005/000108

(22) Date of filing: **15.02.2005**

(87) International publication number:
WO 2005/079662 (01.09.2005 Gazette 2005/35)

(54) IMAGING OF BURIED STRUCTURES

BILDDARSTELLUNG VON VERBORGENEN STRUKTUREN

IMAGERIE D'OBJETS ENFOUIS

(84) Designated Contracting States:
AT BE BG CH CY CZ DE DK EE ES FI FR GB GR HU IE IS IT LI LT LU MC NL PL PT RO SE SI SK TR

- **VAN DER STEEN, Antonius, Franciscus, Wilhelmus**
NL-3043 BD Rotterdam (NL)
- **MASTIK, Frits**
NL-3011 RC Rotterdam (NL)
- **VAN MELICK, Rene, Gerardus, Maria**
NL-1156 BH Marken (NL)

(30) Priority: **19.02.2004 EP 04075541**

(43) Date of publication of application:
13.12.2006 Bulletin 2006/50

(74) Representative: **van Loon, C.J.J. et al**
Vereenigde
Johan de Wittlaan 7
2517 JR Den Haag (NL)

(73) Proprietor: **Nederlandse Organisatie voor Toegepast-Natuurwetenschappelijk Onderzoek TNO**
2628 VK Delft (NL)

(56) References cited:
WO-A-01/15597 WO-A-01/52735
US-A- 5 699 797 US-A1- 2001 027 273
US-A1- 2002 181 762 US-A1- 2003 210 810

(72) Inventors:
 • **WIERINGA, Fokko, Pieter**
NL-6921 JA Duiven (NL)
 • **BAKKER, Dirkjan**
NL-2403 VN Alphen aan den Rijn (NL)

EP 1 729 629 B1

Note: Within nine months of the publication of the mention of the grant of the European patent in the European Patent Bulletin, any person may give notice to the European Patent Office of opposition to that patent, in accordance with the Implementing Regulations. Notice of opposition shall not be deemed to have been filed until the opposition fee has been paid. (Art. 99(1) European Patent Convention).

Description

[0001] The invention relates to a method of obtaining an image of buried structures in an object, in particular to imaging structures such as vascular structures in biological tissue by means of selective combining information derived from tissue images in the visible range and the infra-red range.

[0002] A method describing such is disclosed in the international application WO0115597 by the same inventor. It has been found, that obtaining a sufficiently clear image is difficult due to various problems. One problem is, that light emanating from buried, in particular deeper parts of the object is often much weaker than the light that is reflected directly by the surface of the object. In practice, this means that a separation of the specularly reflected light and light emerging from deeper parts of the object may be needed in order to identify underlying structures.

[0003] While separating these two types of light, for instance by a known method of using polarized light and using the fact that specularly reflected light keeps its polarization direction, so that it can be filtered out by means of a polarizing filter, a substantial amount of the light is lost that is originating from the lower parts of the object, thus resulting in a loss of image brightness and resolution. This invites to the use of powerful light sources in order to receive sufficient light from the lower parts in the process of separating the two parts. However, especially in the area of imaging structures in live objects, there is a maximum amount of light that may be irradiated on the object.

[0004] WO01/50955 shows a reflective arrangement where specular light is filtered by a polarizer. The image of an underlying structure is combined with a visual image to present a single image. However, it has been found that straight-forward combination of these images offers problems, in particular, since certain artefacts occur that are inconvenient to reliably detect and locate an underlying structure.

[0005] US2001/0037811 shows a probe for determining a circumference of a finger. Additionally, the joint is transilluminated for inspecting arthritis inflammation from a scattering analysis. This arrangement cannot be used for visually imaging body parts with a freedom comparable to the human eye.

[0006] US 5,699,797 shows a method for sequentially recording of images at visible and near IR wavelengths and subsequent superposition of the images obtained thereby. The publication discusses the notion of two parallel light beams one, of visible, and the other of IR light. The elimination of artefacts in the IR image is not discussed.

[0007] US 2003/210810-A1 suggests subtracting images taken at different wavelengths.

[0008] WO 01/52735-A suggests detection of structures of interest with edge detection.

[0009] US 2002/181762-A1 shows a composite edge detection system having the edges of several images combined whereby the best focussed edges of each image are selected. No subtraction of edges is suggested.

[0010] The invention has as an object to provide an imaging technique that does not suffer from the afore described problems and that is able to provide an enhanced image of the underlying structure. Moreover, the invention has as an object to provide an imaging enhancement technique to enable a person to combine visual information and information of buried objects in one image.

[0011] To achieve these and other goals, in one aspect, the invention offers a method according to the features of claim 1. In another aspect, the invention offers a method according to the features of claim 13.

[0012] In particular, the invention is used while aligning said infrared light source with a visual light source; providing a first edge analysis of said infrared image; providing a second edge analysis of said visual image; comparing said first and second edge analysis; and discarding edges in said infrared image that are also detected in said second image.

This offers the benefit of obtaining a "normal" visual image (as seen by the human eye), that is enhanced by identifying the underlying structure (detected using infrared light) within the visual image while discarding false edges formed by shadowing or aliasing artifacts (e.g. shadows or reflections from a scalpel or needle). For instance, for surgical purposes, the method offers a convenient tool for deciding an optimal entry point in the object, for instance for cutting tissue or the like.

[0013] Furthermore, by providing a camera for imaging visual and infrared-images; providing a bounded light source for partly irradiating said object by infrared light; partly irradiating said object by said bounded light source; imaging a non-irradiated area of said object by said camera to image said buried structure; and combining said buried structure image with a visual image of said object, infrared light incident on the image that is originating from a direct reflection is spatially filtered out of the image. The remaining partial image hence does not suffer from saturation effects due to direct illumination of specularly reflected light. In a preferred embodiment, a full image is provided by varying said partial irradiation in time so as to provide a full image by subsequent combining of said partial images.

[0014] In a further preferred embodiment, said partial image is obtained by scanning a light beam over said object. In addition or alternatively, said partial image is obtained by subsequently irradiating said object by predetermined patterns. One particularly preferred embodiment comprises obtaining said partial image by alternately irradiating said object by a predetermined complementary patterns. For instance, in an embodiment said patterns may be matrix-patterns, line patterns, dot patterns, concentric or circular patterns.

[0015] Further, preferably said object is irradiated only at predetermined positions that are spaced apart. By spacing the irradiation area and the light detection area, deeper parts of the buried structure may be enhanced.

[0016] By alternatively illuminating said object, a full image may be provided, and wherein all areas of the object are

irradiated in a time-dependent manner.

[0017] The invention further offers particular benefits while using a CMOS-camera, since these camera's have a high degree of decorrelation of adjacent pixels. Thus, the effect of "blooming" is prevented, so that there is a high contrast between the directly reflected area (that is discarded) and the remaining area which receives diffuse light originating from deeper layers.

[0018] Preferably, said edge-detection is performed by a gradient analysis of said first image. The invention offers a convenient embodiment when said images are provided stereoscopically. Furthermore, said first image may be spectrally analysed, and wherein said spectral analysis is projected into said second image. Furthermore, said spectral analysis may comprise a pulsatility analysis and/or a heart beat frequency analysis and/or respiratory frequency analysis. Such analysis thus offers a convenient non-contact tool for measuring body parameters of interest. Under "pulsatility analysis" is understood at least a determination of pulsating parts in the object of interest. The invention is further related to a method of enhancing imaging of buried structures in an object, comprising: as defined in claim 14. Furthermore, the invention is related to a system as defined in claim 16.

[0019] Further features and benefits will become apparent from the figures. In the figures:

Figure 1 shows a schematic view of a scanning irradiating method of an object according to the invention;

Figure 2 shows a schematic view of foton-migration in live tissue due to diffusion;

Figure 3 shows an illumination method by illuminating an overlapping pattern on the object;

Figure 4 shows an illumination method by illuminating a circular patterns on the object;

Figure 5 shows an illumination method by illuminating a grid of patterns on the object;

Figure 6 shows a testing arrangement for testing the apparatus according to the invention using one visible wavelength and two infrared wavelengths;

Figure 7 shows a series of analysis steps for processing and routing of data acquired from the arrangement of Figure 6;

Figure 8 shows a spectral analysis of the pulsatile components in said image for light of three different wavelengths;

Figure 9 shows a simple vizor-like construction comprising the apparatus of the invention;

Figure 10 shows the vizor-like construction of Figure 9 in use;

Figure 11 shows the VIS and NIR images collected by the eyepiece of Figure 9;

Figure 12 illustrates the steps according to the method of the invention; and

Figure 13 shows a further embodiment of the inventive system including an infrared emitting puncture tool.

[0020] Figure 1 shows an alternative to the above described polarization filtering method. This method comprises dynamic complementary lighting/scanning of alternating patterned image sections. This method does not require the use of polarization filters. It is based on the fact that photons entering biological tissue will strongly scatter within the tissue which partly results in backscattering.

[0021] Furthermore the viewed area is divided into parallel linear areas, which we will call "line sections". These line sections can be divided into even and uneven line sections 1, 2 respectively.

[0022] Using a camera that has good anti-blooming specifications and allows the read-out of freely selectable rectangular pixel regions we then can acquire image information in a special sequence.

[0023] During a certain period the bounded light source will light all even line sections 1 and the camera will acquire image information from all uneven line sections 2. Here, the term bounded encompasses light that is bounded spatially, so that an illuminated object comprises, in a direction of view which is also a direction of illumination, non-illuminated areas which are not reached by the bounded light source. Such bounding can be typically reached by focusing, collimating or shielding the light source. Also various other light sources, such as laser lights (e.g. in combination with a holographic grating) and LEDs, can produce bounded lights. During the next period the uneven line sections 2 are lighted and the camera will acquire image information from the even line sections. This can either be done with a line camera that scans the entire tissue or with a normal camera that scans all even lines simultaneously and during the next period all uneven lines.

[0024] In Figure 2 is illustrated how light diffused within the tissue can be used to image deeper parts of the object. Light enters the object at one position 1 and leaves the object at another position 2. From the figure it becomes clear that light entering at further distanced positions can collect information from parts deeper within the object. By applying a variety of illumination patterns as will be further described with reference to Figure 3 - Figure 5, illumination from "within" the object can be achieved, thus imaging deeper parts of the object.

[0025] To this end, in Figure 3, instead of even and uneven parallel lines shown in Figure 1, alternate spatially shifted crossed line patterns can be used as lighting pattern whilst image acquisition occurs within the areas between the lines. It is also possible to first project an "even" dot pattern on the cross point of line pattern 1 and then project an "uneven" dot pattern on the cross sections of line pattern 2. Also, in Figure 4 discrete concentric circular areas can be used. Satisfying results were obtained by a simple test of circular irradiation geometry disclosed in Figure 4. A 6mm thick slice of pink foam (3M ethafoam) was laid upon the shielding pipe. On top of this foam slice a plastic office clamp was placed,

with its' white plastic paper retaining slice laying across it. Finally a second slice of pink foam was laid on top. Outside the camera's field of view, a ring light injected photons of 660 nm, 810 nm and 940 nm into the foam, perpendicular to the foam surface.

5 [0026] Figure 5 shows another embodiment, wherein said object is irradiated only at predetermined positions that are spaced apart. First areas 3 indicated with horizontal lines are irradiated in a first period; second areas 4 with vertical lines are irradiated in a second period. Such a spaced apart configuration is able to show deeper parts of the structure. By varying the spacing, lower and deeper parts of the object may be scanned.

10 [0027] Figure 6 shows a testing arrangement, where an embodiment of the inventive method was tested using known markers such as an SP02 pulse oximeter, an ECG recording devise and a respiratory frequency monitor. The signals were recorded and sampled using the steps indicated in Figure 7. This leads to a pixel by pixel time-analysis of intensity variation. The frames were sampled at a 100Hz Sample rate and the recorded respiration, ECG and plethismographic pulse output were compared. The outcome is illustrated for a variety of wavelengths in Figure 8. It is clearly shown how well the measured variation of the camera matches with the other pulse signals.

15 [0028] A special configuration with added value is based upon two cameras (e.g. CCD or CMOS monochromatic or multiband) positioned at a certain distance from each other (e.g. eye-to-eye distance) thus stereoscopically viewing the same object (e.g. biological tissue), a dual channel electronic image processing device and two display devices placed in front of both eyes.

20 [0029] Between each camera and the viewed object an additional optical system (maybe combining 2 channels) may be placed (e.g., a dual channel microscope, endoscope, colposcope, etc.) It is possible to incorporate a simple vizor-like construction 5 (see Figure 9) so that the device can be either put in front of the eye or be positioned out of the viewing angle to allow normal sight.

25 [0030] Figure 10 shows as an example the stereoscopic eyepiece 5 of Figure 9 in use. For the eyepiece, a color camera can be applied with a bayer color filter pattern of which all filter colors are highly transparent in the NIR-range. Also a multi-layered camera chip (Patent WO 02/27804 to Foveon Inc. or earlier patents like 4,238,760 to Carr) or the approach in our previous patent WO 01 15597 A1 can be applied. Preferably, the images in both spectral ranges match pixel to pixel.

[0031] The surface of the viewed biological tissue region 6 is irradiated at an oblique angle from two opposite sides by two light sources 7. These two sides need not to be aligned with the Left/Right axis of the eyepiece 5, but can be swiveled around in a plane perpendicular to the central axis of the joined cameras.

30 [0032] The light sources 7 can be controlled to independently send out broadband white light in the visible wavelength range (VIS; 400 - 780nm) or narrowband light in the near infrared range (NIR; e.g. 920 nm) as well as in both ranges (VIS & NIR). The light sources 7 are carefully constructed so that the geometrical beam profiles of VIS and NIR are aligned resulting in identical shadowing in the VIS and NIR images. As an alternative also a surgical stereo microscope or an endoscopic dual channel camera (as used in stereoscopic robot surgery) with two side fiber light guides can be used to collect the images.

35 [0033] Figure 11 shows the result of the VIS (Figure 11 A) and NIR (Figure 11 B) images such as collected by the eyepiece 5 illustrated in Figure 10. Since NIR and VIS beams are matched, shadows produced by irregular shapes at the tissue surface (e.g. skin structure, skin folds, molds, etc.) will also match in both wavelength ranges. In the embodiment disclosed, the beams are oriented at a small angle with respect to the tissue region 6. As a result, skin folds etc. will produce sharp-edged shadows. Shiny areas that produce reflections and/or saturated pixels (marked as a star) will also match in both wavelength ranges. Due to the small angle, objects 8 that are brought towards the tissue surface 6 (e.g. needles, scalpels, probes, etc.) will produce two separate shadows. These shadows will meet and typically form a "V" pattern 9 when an object touches the surface. If e.g. a needle punctures the surface, then the needle tip 10 will quickly disappear from the VIS image (Figure 11 A). On the NIR image (Figure 11 B) however, the tip 10 will remain visible within the tissue 6 (see figure).

40 [0034] On the VIS image (Figure 11 A), only very superficial blood vessels will be visible, especially if the texture of the vessel deforms the skin. On the NIR image, however, blood vessels will be visible much better (even blood vessels at a depth of a few millimeters below the surface). Since skin pigment (melanin) has a very low absorbance within the NIR region this good NIR visibility will also be the case with dark skinned persons (also molds will lose their dark color).

45 [0035] After obtaining the NIR and VIS images in steps 11 and 12 respectively, a gradient edge enhancement step is applied for both spectral bands as will be illustrated with reference to Figure 16 (steps 13 and 14). Image VIS-J and NIR-J are obtained by filtering with a smoothing filter to suppress noise from camera image NIR and VIS. In the current implementation this is an averaging filter. From each smoothed images VIS-J and NIR-J, two directional difference images I_x and I_y are calculated by means of a gradient filter. Currently this is performed with a Prewitt filter.

50 [0036] Next edge gradient images VIS-G and NIR-G are made by $\sqrt{(I_x^2 + I_y^2)}$. Then VIS-G and NIR-G are clipped and normalized to 1 to obtain VIS-G' and NIR-G' (Steps 15 and 16). Finally the images are complemented to 1-

G' (Steps 17 and 18).

[0037] For a given tissue region a VIS image and a pixel to pixel matching NIR image are acquired.

[0038] The images from both spectral bands are subjected to an identical edge enhancement algorithm (see above), producing normalized NIR-edge and VIS-edge grayscale images so that edges are encoded black (0 = black and 1 = white; note that this is the negative of normal edge enhanced results).

[0039] Now corresponding edges in the NIR and VIS image are determined (Step 19) according to a pixel by pixel criterion:

NIR-edge-pixel < NIR_Threshold AND VIS-edge-pixel < VIS_Threshold (Thresholds are both software configurable)

[0040] By combining information from both spectral regions, the pixel coordinates that match both requirements are identified as superficial artifacts and are discarded by setting the pixel value to 1 in the corrected NIR edge image (Step 20).

[0041] By doing the same in the raw NIR image after normalizing (Step 21) (no edge enhancement) a corrected normalized NIR image (Step 22) is defined by discarding saturated image areas.

[0042] To this end, the locations of all saturated pixels within the raw NIR image (e.g. 256 for an 8-bit image) are identified. For all pixels within the 1st NIR-mask that are saturated or a direct neighbors of a saturated pixel, the edges are discarded by setting the pixel value to 1 (and thus completely ignoring edge information) is filled in, resulting in a second NIR-mask (step 23).

[0043] False edges resulting from saturated pixels are thus removed and the 2nd NIR-mask now contains the boundaries of subcutaneous blood vessels (and eventual other buried contrasting structures).

[0044] This approach can be varied by including second, third etc. neighboring pixels.

[0045] In a preferred mode, the raw IR image is used to provide "filled in" blood vessels; for example, by multiplying the 2nd NIR-mask with the 2nd corrected NIR image (step 24). The amount of fill-in colorization can be varied with a user adjustable exponent N :

2nd NIR-mask x (1st corrected NIR image)^N = final enhancement

mask

[0046] Finally, this final enhancement mask now is multiplied with the luminosity component of the raw VIS image (which preferably is a color image) in step 25. In this way only contrast information that truly originates from below the tissue surface is projected into the VIS image. If we look at the previous drawings with a needle inserted in tissue it is clear that these criteria will lead to superimposing only the buried needle tip upon the VIS image. Shadows, wrinkles, reflections and the edges of molds will not be enhanced.

[0047] The detection of purely superficial artifacts thus can be further improved when instead of taking all colors of the visible region into account, only the Blue spectral range is used for the VIS edge enhancement input. This is done in order to suppress the visibility of blood vessels. This effect of blue light is because in the visible range, the reflectivity of vessels for blue light is the nearest to skin (the maximum visible vessel contrast lies outside the blue range). As another optional refinement the final enhancement mask may be selectively multiplied with e.g. only the Red and/or Green portion of the visible image (instead of the luminosity signal of the total visible color image).

[0048] When an interesting tissue portion is spotted, the user can switch to a mode that alters the image capturing sequence and allows the collection of an additional (second) NIR image within a selected region of interest (ROI). This ROI is virtually illuminated by photon injection just outside the ROI by means of EITHER a LED-array in contact with the tissue OR a pattern of laser dots or laser lines projected onto the tissue from a distance. During acquisition of this second NIR image the VIS and first NIR lighting are off.

[0049] In this way information obtained using two types of lighting geometries for the same wavelength range can be combined. This can be done with or without also using VIS and flashing needle tip lighting as will be illustrated with reference to Figure 13.

[0050] In Figure 13 a NIR-laser or NIR-LED is plugged onto a needle or catheter 8. Via a sterile window light is projected through or alongside the needle bore. In this way the needle tip 10 illuminates the vessel interior wall 26 when the needle is in the vessel (see fig 13B). If the needle punctures the distal vessel wall (see fig 13C) a drastic change in illumination is seen. The light source clipped to the needle may be synchronized with the cameras. A flashing tip illumination may be beneficial.

[0051] Although in the preceding the invention has been further illustrated with reference to the drawings and the description it will be clear that the invention is not limited thereto and that these embodiments are only disclosed for the purpose of illustration. Variations and modifications thereto are within the scope of the invention as defined in the annexed

claims.

Claims

5

1. A method of obtaining an image of buried structures (8) in an object, comprising:

10

- providing a camera (5) for imaging visual and infrared-images;
- providing a bounded infrared light source;
- partly irradiating said object by said bounded light source;
- imaging a non-irradiated area (2) of said object by said camera to image said buried structure; and
- combining said buried structure image with a visual image of said object
- aligning said infrared light source with a visual light source (7);

15

characterized in that the method further comprises

20

- providing a first edge analysis of said infrared image;
- providing a second edge analysis of said visual image;
- comparing said first and second edge analysis; and
- discarding edges in said infrared image that are also detected in said second image.

2. A method according to claim 1 wherein said irradiation is varied in time so as to provide a full image by subsequent combining of partial images.

25

3. A method according to claim 1 or 2, wherein said image is obtained by scanning a light beam over said object.

4. A method according to claim 1 or 2, wherein said image is obtained by subsequently irradiating said object by predetermined patterns (1,2).

30

5. A method according to claim 4, wherein said partial image is obtained by alternately irradiating said object by said predetermined complementary patterns.

6. A method according to claim 4 or 5, wherein said patterns are matrix-patterns, line patterns, dot patterns or concentric patterns (T1, T2, T3).

35

7. A method according to any of claims 4-6, wherein said object is irradiated only at predetermined positions that are spaced apart.

8. A method according to any of claims 1-7, wherein said image is obtained by a CMOS-camera.

40

9. A method according to claim 1, further comprising:

- correcting said first image to discard saturated image areas.

45

10. A method according to any of the preceding claims, wherein said images are provided stereoscopically.

11. A method according to any of the preceding claims, wherein said first image is spectrally analysed, and wherein said spectral analysis is projected into said second image.

50

12. A method according to claim 11, wherein said spectral analysis comprises a pulsatility analysis and/or a heart beat frequency analysis and/or respiratory frequency analysis.

13. System for obtaining an image of buried structures in an object, comprising:

55

- a bounded infrared light source (7), the light source aligned with a visual light source (7), for partly irradiating said object by light;
- a camera device (5) arranged for obtaining a first buried structure image in a non-irradiated area of the object and for obtaining a second visual image of said object; and

- a processing device arranged to:

- providing a gradient analysis of said first buried structure image in order to detect the edges of said buried structure; and for providing a gradient analysis of said second visual image;
- comparing the gradient analysis of said second visual image with the gradient analysis of said first buried structure image;
- discarding edges in said first buried structure image that are also detected in said second visual image; and
- combining said first and second images for defining edges of said buried structure in said visual image.

5

10 **14.** A system according to claim 13 further comprising:

- a puncture tool (8) for puncturing human tissue; and
- an IR light source (10) provided in said puncture tool.

15

15. A system according to claim 14, wherein said IR light is aligned along said puncture tool.

16. A system according to claim 14 or 15, wherein said IR light is provided in a tip of said puncture tool.

20

17. A system according to any of claims 14-16, wherein said puncture tool is provided with an IR radiating coating.

18. A system according to any of claims 14-17, wherein the IR light source and the bounded light source are alternatingly activated.

25

Patentansprüche

1. Verfahren, um ein Bild von verborgenen Strukturen (8) in einem Objekt zu erhalten, mit:

30

- Bereitstellen einer Kamera (5) zur Bildaufnahme von visuellen Bildern und Infrarot-Bildern;
- Bereitstellen einer begrenzten Infrarot-Lichtquelle;
- teilweise Bestrahlen des Objekts mit der begrenzten Lichtquelle;
- Aufnehmen eines Bildes von einem nicht-bestrahlten Gebiet (2) des Objekts mit der Kamera, um die verborgene Struktur aufzunehmen; und
- Kombinieren des Bildes von der verborgenen Struktur mit einem visuellen Bild des Objekts;
- Ausrichten der Infrarot-Lichtquelle mit einer visuellen Lichtquelle (7);

35

dadurch gekennzeichnet, dass das Verfahren ferner umfasst:

40

- Durchführen einer ersten Kantenanalyse des Infrarot-Bildes;
- Durchführen einer zweiten Kantenanalyse des visuellen Bildes;
- Vergleichen der ersten und der zweiten Kantenanalyse; und
- Löschen der Kanten in dem Infrarot-Bild, die auch in dem zweiten Bild erfasst werden.

45

2. Verfahren nach Anspruch 1, bei dem die Bestrahlung zeitlich so variiert wird, um ein vollständiges Bild durch aufeinanderfolgendes Kombinieren von Teilbildern zur Verfügung zu stellen.

3. Verfahren nach Anspruch 1 oder 2, bei dem das Bild durch Scannen des Objekts mit einem Lichtstrahl erhalten wird.

50

4. Verfahren nach Anspruch 1 oder 2, bei dem das Bild durch aufeinanderfolgendes Bestrahlen des Objekts mit zuvor bestimmten Mustern (1, 2) erhalten wird.

5. Verfahren nach Anspruch 4, bei dem das Teilbild durch abwechselndes Bestrahlen des Objekts mit den zuvor bestimmten komplementären Mustern erhalten wird.

55

6. Verfahren nach Anspruch 4 oder 5, bei dem die Muster Matrix-Muster, Linien-Muster, Punkt-Muster oder konzentrische Muster (T2, T2, T3) sind.

7. Verfahren nach einem der Ansprüche 4-6, bei dem das Objekt bei zuvor bestimmten Positionen bestrahlt wird, die

EP 1 729 629 B1

voneinander beabstandet sind.

8. Verfahren nach einem der Ansprüche 1-7, bei dem das Bild durch eine CMOS-Kamera erzeugt wird.

5 9. Verfahren nach Anspruch 1, außerdem mit:

- Korrigieren des ersten Bildes, um gesättigte Bildgebiete zu löschen.

10 10. Verfahren nach einem der vorhergehenden Ansprüche, bei dem die Bilder stereoskopisch erhalten werden.

11. Verfahren nach einem der vorhergehenden Ansprüche, bei dem das erste Bild spektral analysiert wird und bei dem diese spektrale Analyse in das zweite Bild projiziert wird.

15 12. Verfahren nach Anspruch 11, bei dem die spektrale Analyse eine Pulsatilitätsanalyse und/oder ein Herzschlagfrequenzanalyse und/oder eine Atmungsfrequenzanalyse umfasst.

13. System, um ein Bild von verborgenen Strukturen in einem Objekt zu erhalten, mit:

20 - einer begrenzten Infrarot-Lichtquelle (7), wobei die Lichtquelle mit einer visuellen Lichtquelle (7) ausgerichtet ist, um das Objekt teilweise mit Licht zu bestrahlen;

- einer Kameravorrichtung (5), die ausgestaltet ist, um ein erstes Bild von verborgenen Strukturen in einem nicht-bestrahlten Gebiet des Objekts zu erhalten und um ein zweites visuelles Bild des Objekts zu erhalten; und

- einer Verarbeitungsvorrichtung, die ausgestaltet ist, um:

25 - eine Gradientenanalyse des ersten Bildes von verborgenen Strukturen zur Verfügung zu stellen, um die Kanten der verborgenen Struktur zu erfassen; und um eine Gradientenanalyse des zweiten visuellen Bildes zur Verfügung zu stellen;

- die Gradientenanalyse des zweiten visuellen Bildes mit der Gradientenanalyse des ersten Bildes von verborgenen Strukturen zu vergleichen;

30 - Kanten in dem ersten Bild von verborgenen Strukturen zu löschen, die auch in dem zweiten visuellen Bild erfasst werden; und

- das erste und das zweite Bild zu kombinieren, um Kanten der verborgenen Struktur in dem visuellen Bild zu definieren.

35 14. System nach Anspruch 13, außerdem mit:

- ein Punktionswerkzeug (8) zum Punktieren von menschlichem Gewebe; und

- einer IR-Lichtquelle (10), die in dem Punktionswerkzeug vorgesehen ist.

40 15. System nach Anspruch 14, bei dem das IR-Licht entlang des Punktionswerkzeugs ausgerichtet ist.

16. System nach Anspruch 14 oder 15, bei dem das IR-Licht in einer Spitze des Punktionswerkzeugs vorgesehen ist.

45 17. System nach einem der Ansprüche 14-16, bei dem das Punktionswerkzeug mit einer IR-Abstrahlbeschichtung versehen ist.

18. System nach einem der Ansprüche 14-17, bei dem die IR-Lichtquelle und die begrenzte Lichtquelle alternativ aktiviert werden.

50

Revendications

1. Procédé d'obtention d'une image de structures enfouies (8) dans un objet, comprenant :

55 - la fourniture d'une caméra (5) pour produire des images visuelles et des images infrarouges ;

- la fourniture d'une source de lumière infrarouge limitée ;

- l'irradiation d'une partie dudit objet par ladite source de lumière limitée ;

- la production d'une image d'une région non irradiée (2) dudit objet au moyen de ladite caméra pour produire

EP 1 729 629 B1

une image de ladite structure enfouie, et

- la combinaison de ladite image de structure enfouie avec une image visuelle dudit objet
- l'alignement de ladite source de lumière infrarouge avec une source de lumière visuelle (7) ;

5 **caractérisé en ce que** le procédé comprend en outre

- la fourniture d'une première analyse des contours de ladite image infrarouge ;
- la fourniture d'une seconde analyse des contours de ladite image visuelle ;
- la comparaison desdites première et seconde analyses des contours ; et
- l'élimination, dans ladite image infrarouge, des contours qui sont également détectés dans ladite seconde image.

10

2. Procédé selon la revendication 1, **caractérisé en ce que** l'on fait varier dans le temps ladite irradiation de façon à fournir une image complète par combinaison subséquente d'images partielles.

15

3. Procédé selon la revendication 1 ou la revendication 2, **caractérisé en ce que** ladite image est obtenue par balayage dudit objet par un faisceau lumineux.

20

4. Procédé selon la revendication 1 ou la revendication 2, **caractérisé en ce que** ladite image est obtenue par irradiation subséquente dudit objet selon des motifs prédéterminés (1, 2).

5. Procédé selon la revendication 4, **caractérisé en ce que** ladite image partielle est obtenue en irradiant en alternance ledit objet selon lesdits motifs complémentaires prédéterminés.

25

6. Procédé selon la revendication 4 ou la revendication 5, **caractérisé en ce que** lesdits motifs sont des motifs de matrices, des motifs de lignes, des motifs de points ou des motifs concentriques (T1, T2, T3).

7. Procédé selon l'une quelconque des revendications 4 à 6, **caractérisé en ce que** ledit objet est irradié uniquement à des emplacements prédéterminés, distants les uns des autres.

30

8. Procédé selon l'une quelconque des revendications 1 à 7, **caractérisé en ce que** ladite image est obtenue au moyen d'une caméra CMOS.

9. Procédé selon la revendication 1, comprenant en outre :

35

- la correction de ladite première image pour éliminer les zones d'image saturées.

10. Procédé selon l'une quelconque des revendications précédentes, **caractérisé en ce que** lesdites images sont fournies stéréoscopiquement.

40

11. Procédé selon l'une quelconque des revendications précédentes, **caractérisé en ce que** ladite première image est soumise à une analyse spectrale et **en ce que** ladite analyse spectrale est projetée dans ladite seconde image.

12. Procédé selon la revendication 11, **caractérisé en ce que** ladite analyse spectrale comprend une analyse de pulsativité et/ou une analyse de la fréquence cardiaque et/ou une analyse de la fréquence respiratoire.

45

13. Système permettant d'obtenir une image de structures enfouies dans un objet, comprenant :

- une source de lumière infrarouge limitée (7), la source de lumière alignée avec une source de lumière visuelle (7), pour irradier une partie dudit objet avec de la lumière ;
- un dispositif de caméra (5) agencé pour obtenir une première image de structure enfouie dans une zone non irradiée de l'objet et pour obtenir une seconde image visuelle dudit objet ; et
- un dispositif de traitement agencé pour :

50

- fournir une analyse de gradient de ladite première image de structure enfouie afin de détecter les contours de ladite structure enfouie ; et pour fournir une analyse de gradient de ladite seconde image visuelle ;
- comparer l'analyse de gradient de ladite seconde image visuelle à l'analyse de gradient de ladite première image de structure enfouie ;

55

EP 1 729 629 B1

- éliminer, dans ladite première image de structure enfouie, les contours qui sont également détectés dans ladite seconde image visuelle ; et
- combiner lesdites première et seconde images pour définir les contours de ladite structure enfouie dans ladite image visuelle.

5

14. Système selon la revendication 13, comprenant en outre :

- un instrument de perforation (8) permettant de percer les tissus humains ; et
- une source de lumière IR (10) logée dans ledit instrument de perforation.

10

15. Système selon la revendication 14, **caractérisé en ce que** ladite lumière IR est alignée avec ledit instrument de perforation.

15

16. Système selon la revendication 14 ou la revendication 15, **caractérisé en ce que** ladite lumière IR est émise à la pointe dudit instrument de perforation.

17. Système selon l'une quelconque des revendications 14 à 16, **caractérisé en ce que** ledit instrument de perforation est pourvu d'un revêtement émettant un rayonnement infrarouge.

20

18. Système selon l'une quelconque des revendications 14 à 17, **caractérisé en ce que** la source de lumière IR et la source de lumière limitée sont activées en alternance.

25

30

35

40

45

50

55

Figure 1

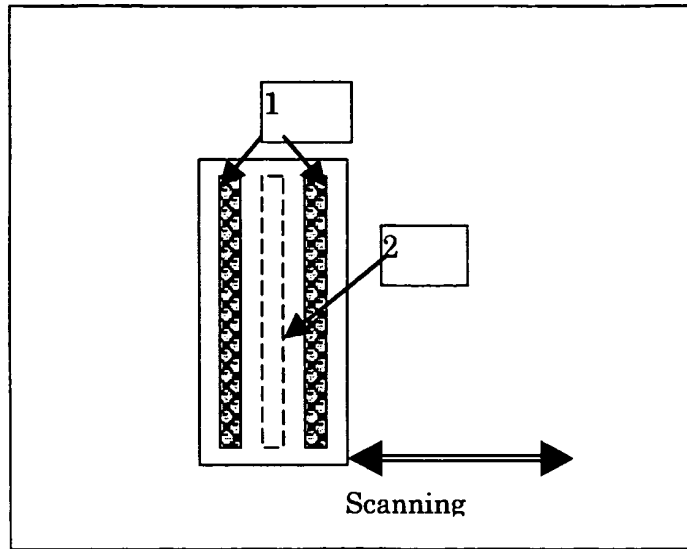

Device viewed from the irradiated tissue side

Figure 2

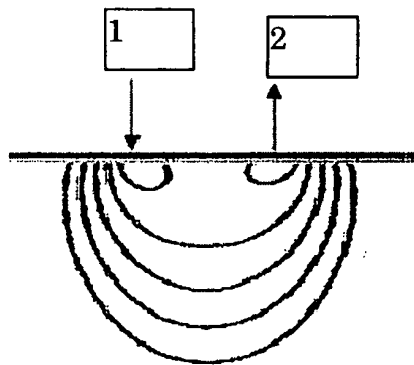

Figure 3

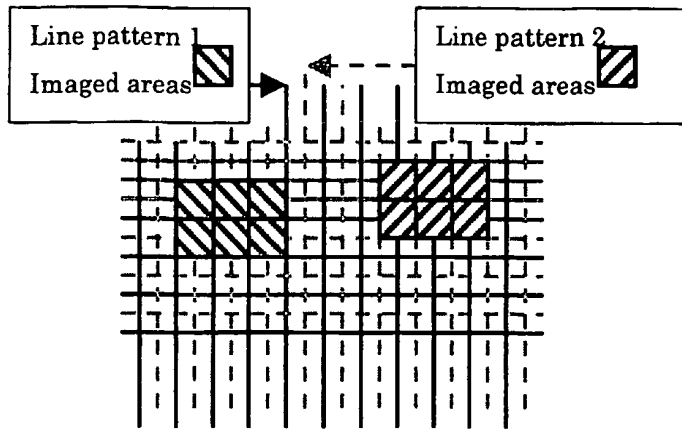

Figure 4

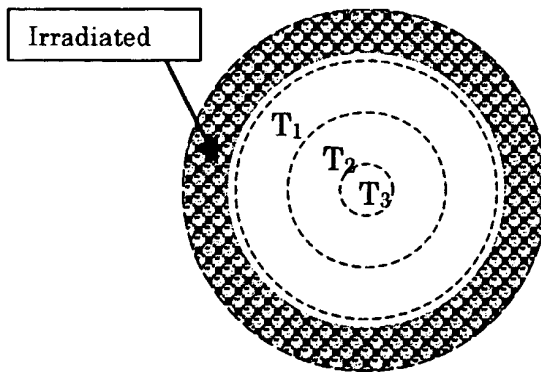

Figure 5

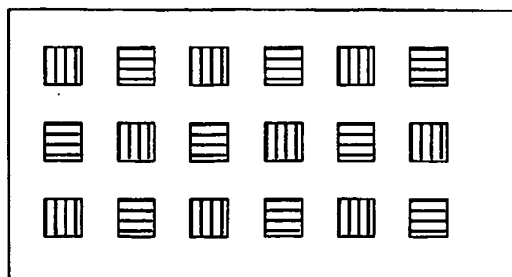

Figure 6

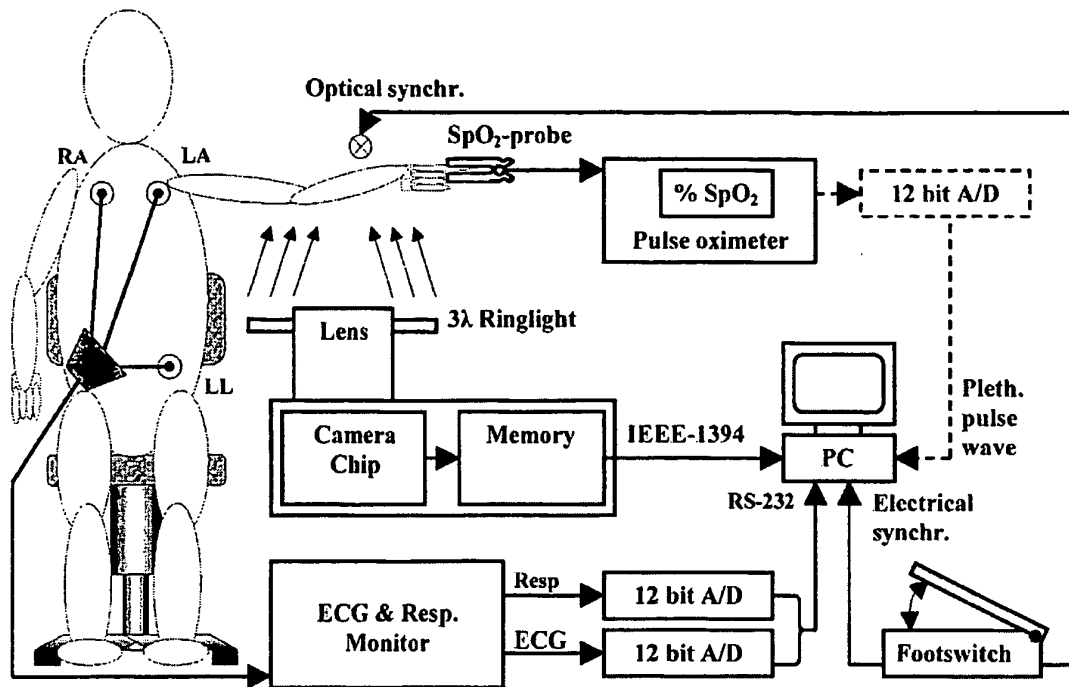

Figure 7

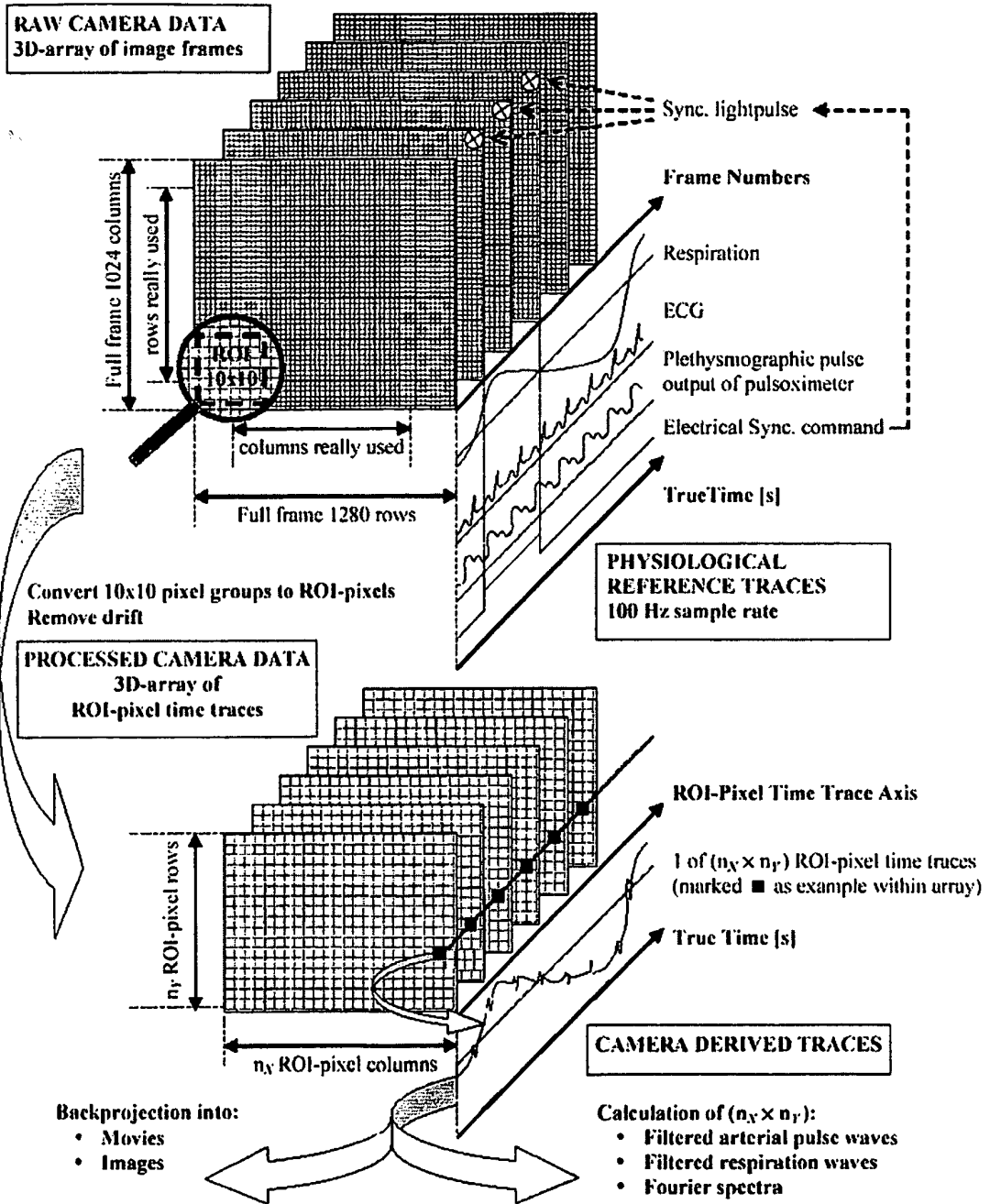

Figure 8

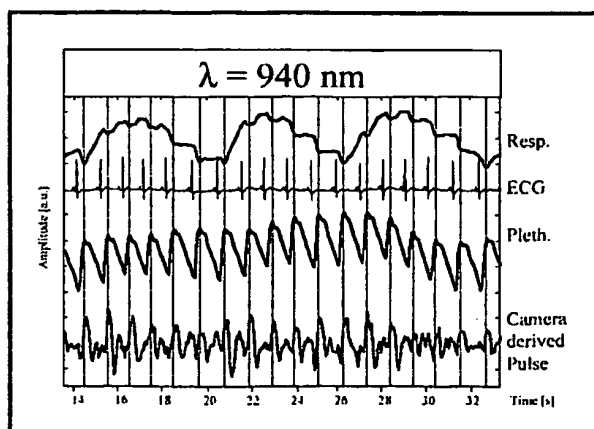
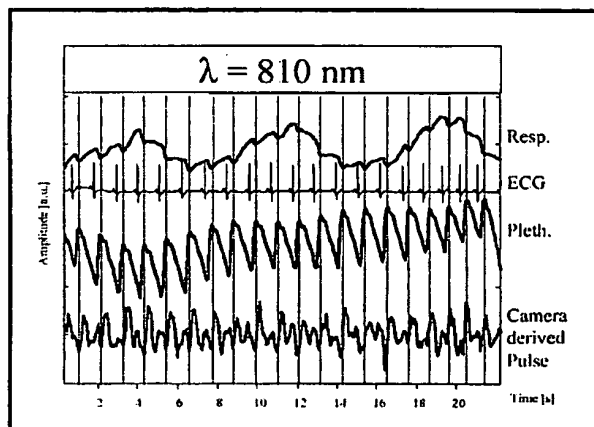
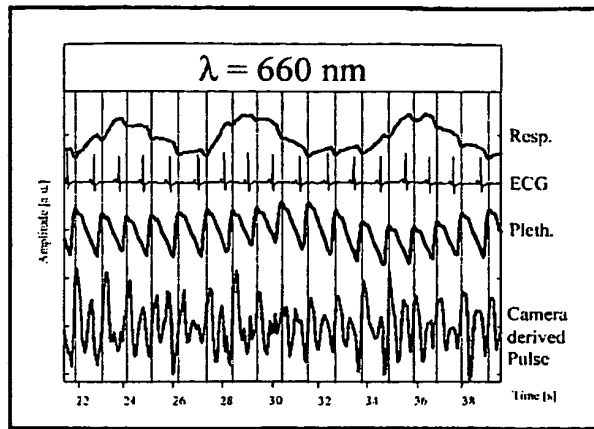

Figure 9

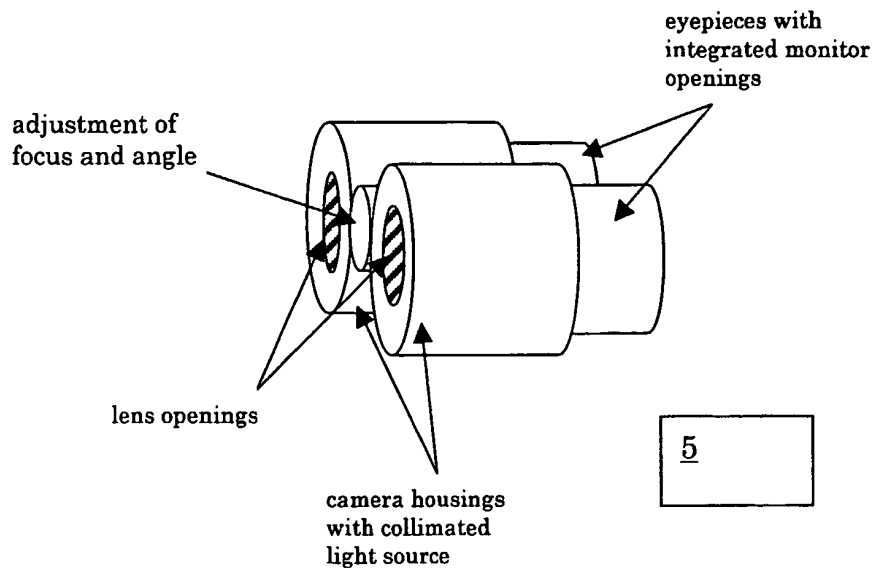

Figure 10

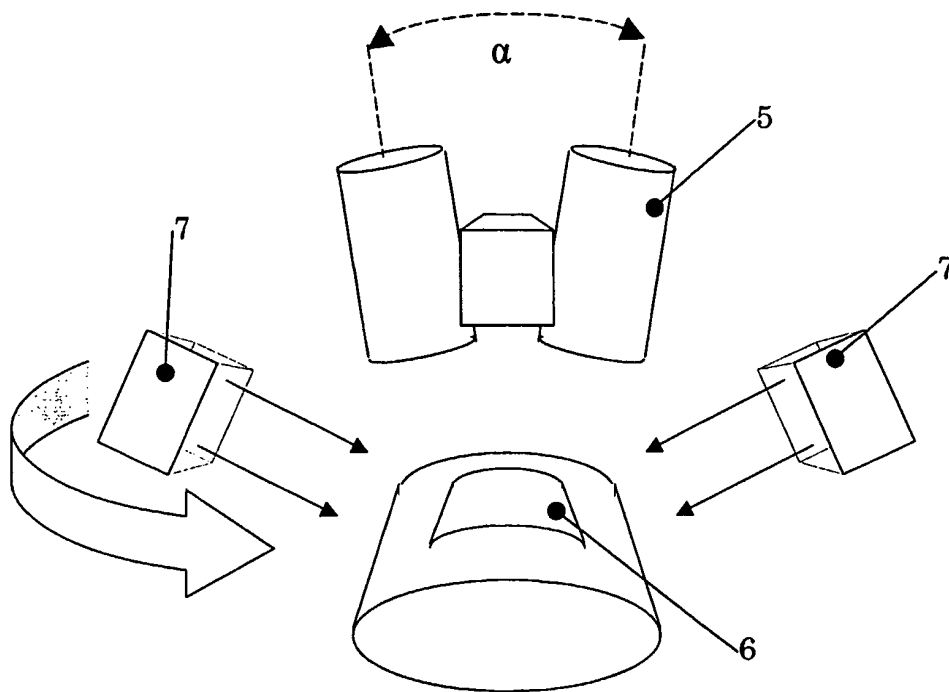

Figure 11

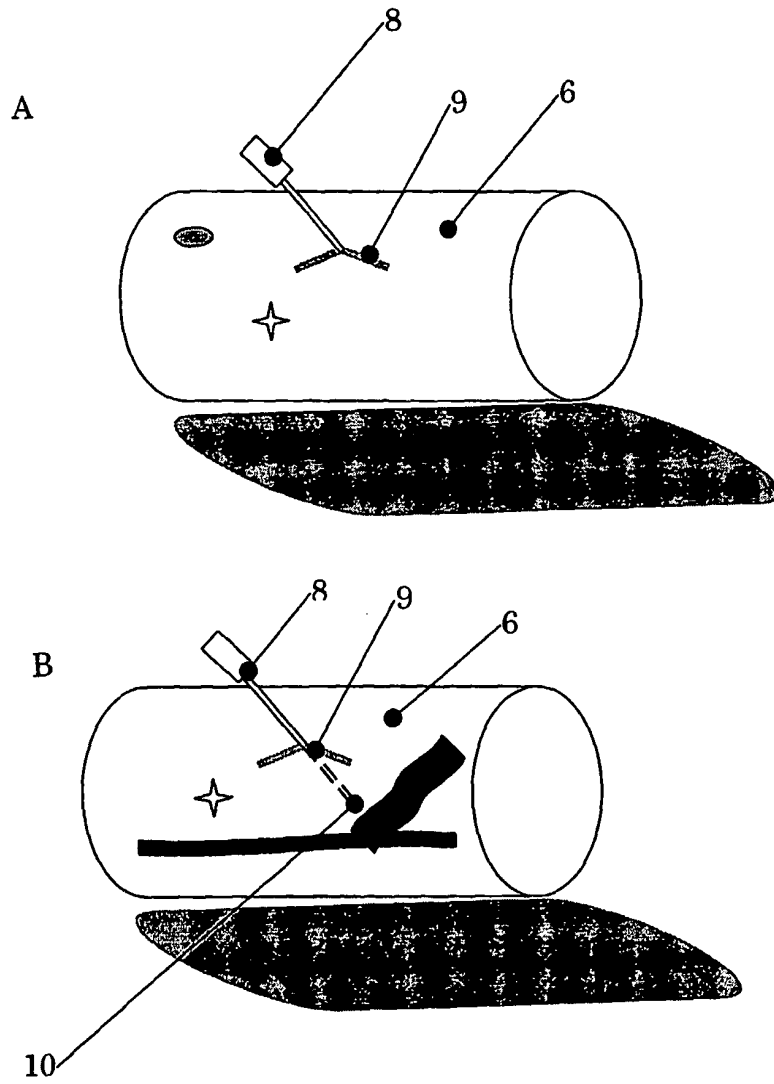

Figure 16

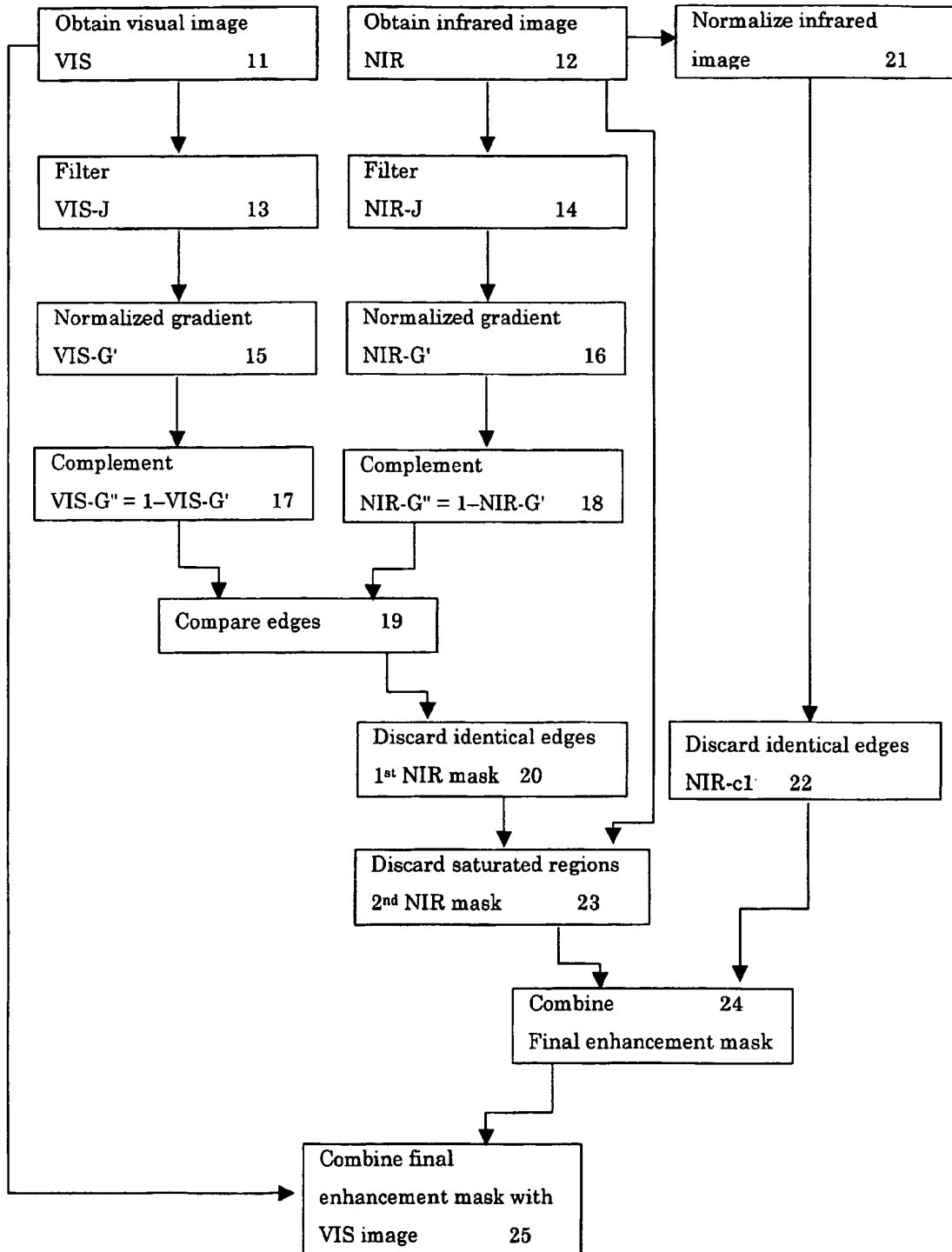
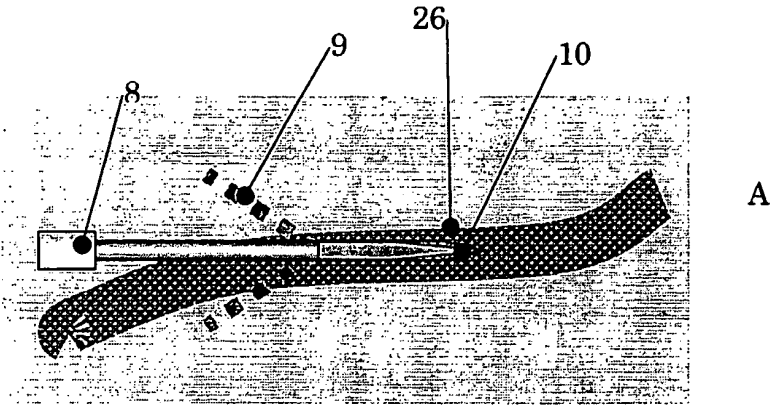
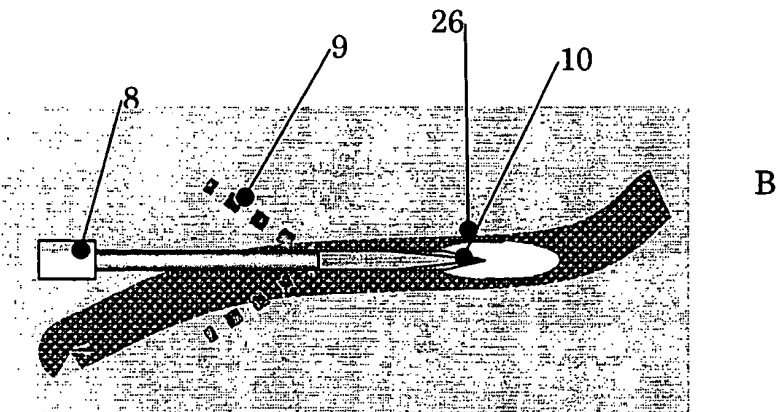

Figure 13



A



B

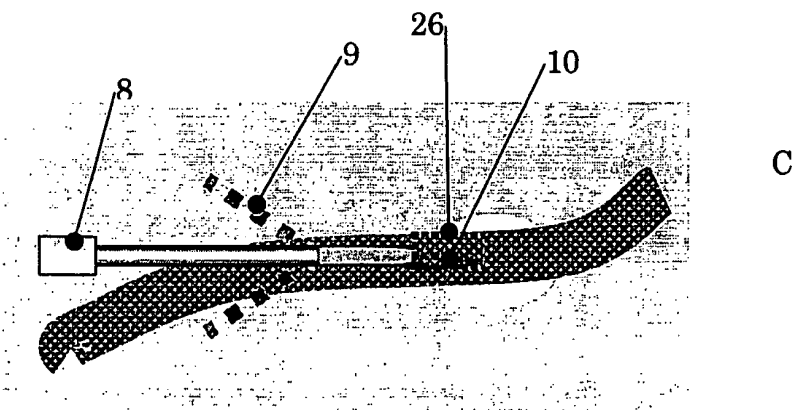

C

REFERENCES CITED IN THE DESCRIPTION

This list of references cited by the applicant is for the reader's convenience only. It does not form part of the European patent document. Even though great care has been taken in compiling the references, errors or omissions cannot be excluded and the EPO disclaims all liability in this regard.

Patent documents cited in the description

- WO 0115597 A [0002]
- WO 0150955 A [0004]
- US 20010037811 A [0005]
- US 5699797 A [0006]
- US 2003210810 A1 [0007]
- WO 0152735 A [0008]
- US 2002181762 A1 [0009]
- WO 0227804 A [0030]
- WO 0115597 A1 [0030]

专利名称(译)	埋藏结构的成像		
公开(公告)号	EP1729629B1	公开(公告)日	2009-11-11
申请号	EP2005710889	申请日	2005-02-15
[标]申请(专利权)人(译)	荷兰应用自然科学研究组织		
申请(专利权)人(译)	NEDERLANDSE ORGANISATIE VOOR TOEGEPAST-NATUURWETENSCHAPPELIJK ONDERZOEK TNO		
当前申请(专利权)人(译)	NEDERLANDSE ORGANISATIE VOOR TOEGEPAST-NATUURWETENSCHAPPELIJK ONDERZOEK TNO		
[标]发明人	WIERINGA FOKKO PIETER BAKKER DIRKJAN VAN DER STEEN ANTONIUS FRANCISCUS WILHELMUS MASTIK FRITS VAN MELICK RENE GERARDUS MARIA		
发明人	WIERINGA, FOKKO, PIETER BAKKER, DIRKJAN VAN DER STEEN, ANTONIUS, FRANCISCUS, WILHELMUS MASTIK, FRITS VAN MELICK, RENE, GERARDUS, MARIA		
IPC分类号	A61B5/00 A61B5/103 G01N21/47 G06T5/50 G06T5/00 G01N21/35		
CPC分类号	A61B5/0059 A61B5/0064 A61B5/489 A61B2562/0242 G01N21/35 G01N21/359 G06T7/12 G06T7/174 G06T2207/10048 G06T2207/20224 G06T2207/30076 G06T2207/30101		
优先权	2004075541 2004-02-19 EP		
其他公开文献	EP1729629A1		
外部链接	Espacenet		

摘要(译)

一种获得物体中的掩埋结构的图像的方法，包括：提供用于对视觉和红外图像成像的相机；提供有界光源；通过所述有界光源部分地照射所述物体；通过所述相机对所述物体的未照射区域成像，以对所述掩埋结构成像；将所述掩埋结构图像与所述物体的视觉图像相结合。因此，可以在丢弃物体的镜面反射的同时获得图像。另外，公开了一种增强物体中的掩埋结构的成像的方法，包括：将所述红外光源与可见光源对准；提供所述红外图像的第一边缘分析；提供所述视觉图像的第二边缘分析；比较所述第一和第二边缘分析；并且丢弃在所述第二图像中也检测到的所述红外图像中的边缘。

$$\sqrt{(I_x^2 + I_y^2)}$$