



(11) **EP 1 376 465 B1**

(12) **EUROPEAN PATENT SPECIFICATION**

(45) Date of publication and mention of the grant of the patent:
15.04.2009 Bulletin 2009/16

(21) Application number: **02700728.5**

(22) Date of filing: **25.02.2002**

(51) Int Cl.:
G06T 1/00 (2006.01) A61B 5/117 (2006.01)

(86) International application number:
PCT/JP2002/001635

(87) International publication number:
WO 2002/069260 (06.09.2002 Gazette 2002/36)

(54) **ORGANISM AUTHENTICATING APPARATUS**

VORRICHTUNG ZUM AUTENTIFIZIEREN VON ORGANISMEN

APPAREIL D'AUTHENTIFICATION D'ORGANISME

(84) Designated Contracting States:
CH DE FR GB LI

(30) Priority: **26.02.2001 JP 2001049823**
05.07.2001 JP 2001204314

(43) Date of publication of application:
02.01.2004 Bulletin 2004/01

(73) Proprietor: **Bionics Co., Ltd.**
Nishi-ku,
Osaka-shi,
Osaka 550-0004 (JP)

(72) Inventors:
• **CHOSHI, Kinya,**
BIONICS CO., LTD.
Nishi-ku, Osaka-shi, Osaka 550-0004 (JP)
• **KANEDA, Yusuke,**
BIONICS CO., LTD.
Nishi-ku, Osaka-shi, Osaka 550-0004 (JP)

(74) Representative: **TBK-Patent**
Bavariaring 4-6
80336 München (DE)

(56) References cited:
JP-A- 7 021 373 **JP-A- 7 171 137**
JP-A- 10 127 609 **JP-A- 11 015 948**
JP-A- 11 102 431 **JP-A- 11 197 135**
JP-A- 11 203 452 **JP-A- 11 347 015**
JP-A- 2000 005 148

- **PATENT ABSTRACTS OF JAPAN vol. 1998, no. 10, 31 August 1998 (1998-08-31) & JP 10 127609 A (HITACHI LTD), 19 May 1998 (1998-05-19)**
- **PATENT ABSTRACTS OF JAPAN vol. 1999, no. 12, 29 October 1999 (1999-10-29) & JP 11 203452 A (HITACHI LTD), 30 July 1999 (1999-07-30)**
- **PATENT ABSTRACTS OF JAPAN vol. 2000, no. 04, 31 August 2000 (2000-08-31) & JP 2000 005148 A (HITACHI LTD), 11 January 2000 (2000-01-11)**

EP 1 376 465 B1

Note: Within nine months of the publication of the mention of the grant of the European patent in the European Patent Bulletin, any person may give notice to the European Patent Office of opposition to that patent, in accordance with the Implementing Regulations. Notice of opposition shall not be deemed to have been filed until the opposition fee has been paid. (Art. 99(1) European Patent Convention).

Description

TECHNOLOGY AREA OF THE INVENTION

[0001] The invention provides an organism authenticating apparatus, or especially an organism authenticating apparatus that realizes high authentication accuracy by a simple apparatus structure.

BACKGROUND OF THE INVENTION

[0002] Several authentication methods using an image of a blood vessel pattern of a human hand have been proposed recently as one way of organism authenticating. In JP, A, H08-508419, for example, an apparatus for authenticating a person by using a vein image of the back of a human hand is presented.

[0003] Document JP 10127609 discloses a living body identifying device which realizes an individual identification by picking up the image of the blood vessel of a living body or the living body external shape of a part where its blood vessel runs.

[0004] Document JP 11203452 discloses a personal feature pattern detector and a personal identification device using the detector capable of detecting a human vein pattern without being influenced by stains, wrinkles or the like.

[0005] Such conventional organism authenticating methods as exemplified above, however, have several drawbacks; it is difficult to get a clear blood vessel image, the apparatus size cannot be small enough for actual applications, and there is a possibility that a wrong person is authenticated as the principal.

DISCLOSURE OF THE INVENTION

[0006] The purpose of the invention is to solve such problems of conventional technologies and to provide an organism authenticating apparatus that enables authenticating an organism at high accuracy using a simple apparatus structure.

[0007] In order to attain this purpose, the organism authenticating apparatus of this invention comprises a means adapted to fix the position of a hand or a finger of a hand, an infrared ray radiating means adapted to radiate infrared rays, an infrared ray image input means that is placed at the opposite side of said hand or said finger of a hand with regard to said infrared ray radiating means, an organism recognizing means adapted to recognize that the organism is live, a processing means adapted to process data that are inputted by said infrared ray image input means so that it collates them with image data that are registered in advance and an output means adapted to output the result of processing carried out by said processing means, characterized in that said organism recognizing means is adapted to measure, in order to recognize the organism, the temperature, the resistance and the impedance at a specified frequency of the

hand or the finger to be recognized, by using electrodes or a temperature sensitive element that are attached to said means that fixes the position of a hand or a finger of a hand.

5 **[0008]** By applying this invention, it becomes possible to obtain a clear blood vessel pattern image by a compact size apparatus by using an infrared ray source and by capturing the passed-through infrared ray image of the organism, and it becomes possible by using an organism
10 recognizing means to prevent false authentication.

DESCRIPTION OF DRAWINGS

[0009]

15 Figure 1 is a figure to explain the structure of a room entrance management system that uses the organism authenticating apparatus of the invention.

Figure 2 is a figure to show the structure of the organism authenticating apparatus of the invention by using the front view and the cross-section view from the right side of the apparatus.

Figure 3 is a cross-section view to show the structure of the gripping portion 24 and the image input portion 23.

Figure 4 is a figure to show the structure of the gripping portion 24 by using the front view and the side view.

Figure 5 is a block diagram to show the circuit structure of the organism authenticating apparatus of the invention.

Figure 6 is a front cross-section view to show the structure of the second embodiment example of the gripping portion 24.

35 Figure 7 is a flowchart to show the contents of the control program of the invention.

Figure 8 is a flowchart to show the contents of the registration process.

Figure 9 is a block diagram to show the second embodiment example of the invention.

40 Figure 10 is a figure to show the structure of the authentication unit in the second embodiment example of the invention.

Figure 11 is a block diagram to show the circuit structure for each unit in the second embodiment example of the invention.

Figure 12 is a block diagram to show the structure of the resistance detection circuit in the second embodiment example of the invention.

Figure 13 is a block diagram to show the structure of the temperature detection circuit in the second embodiment example of the invention.

Figure 14 is a circuit diagram to show the structure of the capacity detection circuit in the second embodiment example of the invention.

55 Figure 15 is a figure to explain the structure of the spatial filter in the second embodiment example of the invention.

Figure 16 shows flowcharts to show the contents of the registration processes in the second embodiment example of the invention.

Figure 17 shows flowcharts to show the contents of the authentication process and the deletion process in the second embodiment example of the invention.

DESCRIPTION OF PREFERRED EMBODIMENT

[0010] Preferred embodiment examples of the invention are explained in detail in the following, referring to figures.

THE FIRST PREFERRED EMBODIMENT EXAMPLE

[0011] Figure 1 is a figure to explain the structure of a room entrance management system that uses the organism authenticating apparatus of the invention. In the figure, the organism authenticating apparatus of the invention 13 is connected to the electric lock 12 on a door 11. The door is normally locked by the lock. A person who intends to enter the room first inputs the person's ID number by using the ten-key input board on the front panel of the organism authenticating apparatus 13. The person then puts the person's hand in the aperture of the apparatus and holds the gripping portion within the apparatus.

[0012] When the organism authenticating apparatus 13 detects that the hand holds the gripping portion, the apparatus 13 lights infrared ray emitting diodes within the gripping portion, inputs the passed-through infrared ray image of the hand by using a CCD image captor attached above the gripping portion and then collates the inputted image data with image data of permitted persons that are registered in advance. If the person is authenticated by the collation, the electric lock 12 is driven to open. Although it is not indispensable for the invention, the computer 10 is used for recording entrance and exit of persons, storing registered persons' data and executing maintenance and monitoring jobs.

[0013] Figure 2 shows the structure of the organism authenticating apparatus of the invention by using the front view and the cross-section view from the right side of the apparatus. A ten-key input board 20 and LED's 21 for status indication are mounted on the front panel at the upper portion of the organism authenticating apparatus 13. An aperture 22 is provided at the lower portion of the organism authenticating apparatus 13. The inside of the aperture 13 is shaped like a box wherein a gripping portion 24 with pins 36 on it is horizontally located at the center of the box.

[0014] The image input portion 23, which is actually a CCD image captor, is installed at the inner upper portion of the box, and a sterilizing apparatus 25 that generates ozone for sterilization is installed at the upper end portion of the box. A rotary lid or a curtain may be attached to the apparatus to cover the aperture 22. A printed board 26 on which control circuits that will be explained later

are mounted and a power supply unit 27 are also equipped within the organism authenticating apparatus 13.

[0015] Figure 3 is a cross-section view to show the structure of the gripping portion 24 and the image input portion 23. Figure 4 shows the structure of the gripping portion 24 by using the plane view and the side view. The cross section shape of the gripping portion 24 is a rectangle with round corners as shown in Fig. 3. The gripping portion 24, or at least the upper portion of the gripping portion 24, is made from material that passes through infrared rays such as acryl or vinyl chloride. The gripping portion 24 contains a cavity, and within it the light source board 35 is equipped on which many infrared ray emitting diodes 34 that radiate infrared rays at the wavelength around 850nm are mounted.

[0016] Two metal pins 36 and a thermister 46 for temperature measurement are mounted at the back side of the gripping portion 24. The space between those two pins is set to a size that the middle finger of a hand fits in. Although connecting wires are not drawn in figures, pins 36, the thermister 46 and the light source board 35 are connected to the control board 26.

[0017] The image input portion 23 that is installed at the inner upper portion of the organism authenticating apparatus 13 consists of a CCD camera 30, a lens 31 and two optical filters 32 and 33 as shown in Fig. 3. An ordinary CCD camera and lenses that are available on the market can be used as far as they have reasonable sensitivity in the infrared region. The first filter 32 passes only rays with wavelengths longer than 750nm, for example, and the second filter passes only rays with wavelengths shorter than 900nm, for example. By using these two filters as a pair, a band pass filter with the pass band between 750nm and 900nm can be obtained.

[0018] In contrast to conventional methods that can obtain only an image of a vein pattern near the surface of a hand by using the reflected light for taking the image, the organism authentication apparatus of this invention can take a clear image of a blood vessel pattern not only for veins but also for arteries within the hand by using infrared rays passed through the hand for taking the image, as Fig. 3 shows. Bones in the hand do not disturb the blood vessel pattern image, since infrared rays pass through bones.

[0019] Figure 5 is a block diagram to show the circuit structure of the organism authenticating apparatus of the invention. The one-chip computer 40 in the figure is a commercially available 16bit one-chip computer having such circuits as a CPU, a ROM, a RAM, I/O ports, a memory bus, a clock circuit and an interruption circuit. The CCD camera interface circuit 41 takes digital image information (multi-level luminosity data) that is outputted by the CCD camera 30 into the computer 40.

[0020] The parallel I/O port 42 takes input data from the ten-key input board 20, and controls turning on and off the LEDs for displaying 21, the LEDs as infrared light sources 34 and the sterilizing apparatus 25. The steriliz-

ing apparatus 25 is driven by a driver circuit that is not shown in the figure. The infrared LEDs for lighting 34 are driven by current that exceeds the luminosity saturation current value at which LED luminosity will not increase any more, in order to assure uniform lighting by reducing luminosity difference among LEDs.

[0021] The D/A conversion function of the D/A and A/D converters 43 converts the digital driving signal to the analog driving signal and applies it to the buffer amplifier 44, in order to provide the driving signal to one of the two pins 36. The A/D conversion function of the D/A and A/D converters 43 converts the analog voltage (signal) of the other one of two pins 36 to a digital signal, and also converts the analog output signal of the buffer amplifier 47 that is fed from the temperature sensor (thermister) 46 to a digital signal. Buffer amplifiers 44, 45 and 47 are operational amplifiers (DC amplifiers).

[0022] The flush ROM 50 is used mainly for storing registered image data. An arbitral storage device such as an EE PROM, an SRAM, a hard disk or a floppy disk can be also used for this purpose, or the data can be directly read from the computer 10 shown in Fig. 1.

[0023] The communication driver 51 provides the line driver function and the line receiver function that conform to RS-232C specifications, for example. The power supply circuit 52 provides the whole organism authenticating apparatus with electric voltages by taking in electric power from the commercial electric source, or from a battery that is equipped in the organism authenticating apparatus in preparation for a power failure. The lock driver 53 outputs a signal to drive the solenoid of the electric lock 12 for opening the lock under the control of the one-chip computer 40.

[0024] Figure 7 is a flowchart to show the contents of the control program of the invention. At the step S10 in the figure, input data is inputted by using the ten-key input board and stored. At the step S11, whether the inputted data matches the data corresponding to the ENT (ENTER) key or not is checked. The process moves to the S12 if the result is "Yes", and goes back to S10 if it is "No".

[0025] The sterilizing apparatus is switched off at the step S12. Whether the inputted ID number has been already registered or not is checked at the step S13 by comparing the inputted ID number with the registered ones. The process jumps to S26 if the result is "No", and proceeds to S14 if "Yes". The registered data for collation corresponding to the inputting ID number is read out at the step S14.

[0026] At the step S15, a DC voltage with a predetermined value is applied to one of the two pins 36 via the D/A conversion function of the D/A and A/D converters 43 and via the buffer amplifier 44, and then the electric potential at the other one of the two pins 36 is measured via the buffer amplifier 45 and via the A/D conversion function of the D/A and A/D converters 43. Then, whether a human hand is touched to the two pins or not is decided by checking whether the value of the measured electric potential is within a predetermined value range or not. If

the measured electric potential does not exceed a predetermined value within a certain predetermined time period, or if the CL (clear) key of the ten-key input board is pushed down, the process goes to the step S26.

[0027] At the step S16, the impedance between the two pins 36 is measured. In more detail, an AC voltage with a predetermined amplitude and a predetermined frequency (several tens of KHz, for example) is applied to one of the two pins 36 through the D/A conversion function of the D/A and A/D converters 43 and the buffer amplifier 44, and the voltage waveform at the other one of the two pins 36 is read through the amplifier 45 and the A/D conversion function of the D/A and A/D converters 43. Whether an organism touches to the pins or not is decided by checking whether the amplitude and the phase of the inputted voltage waveform are within a predetermined range or not.

[0028] At the step S17, the electric potential that is outputted by the temperature sensor (thermister) 46 is read after A/D conversion, and whether the inserted object is an organism or not is decided by checking whether the measured result is within a predetermined value range or not. At the step S18, whether all of the checking results by steps S15, 16 and 17 indicate that the inserted object is an organism or not. If not, the process jumps to the step S26, and if yes, the step S19 follows.

[0029] Infrared LEDs for lighting are lit at the step S19, and then at the step 20, the CCD camera 30 is activated to take an infrared ray image through the interface circuit 41. Infrared LEDs for lighting are distinguished at the step S21. Since a large electric current is required to drive infrared LEDs, the electric current is controlled to flow only for a minimum time period necessary for image obtaining.

[0030] At the step S22, the inputted image data is processed for edge (contrast) stressing, binary coding and further vectorization, for example, and then feature extraction is carried out by using positions and relationships between end points or branch points of the image. At the step S23, the extracted feature point data is collated to the registered feature point data that is read out at the step S14. Conventional already-known methods for image processing, extracting feature points and collating can be applied to the processes explained above.

[0031] At the step S24, whether the result of collation is affirmative or not, that is, whether the person is the principal or not is decided. If the result is "No", the process jumps to the step S26, and if "Yes", then the step S25 follows. At the step S25, the LED for showing that authentication is passed is lit and the electric lock 12 is opened by driving the lock driver 53.

[0032] The sterilizing apparatus is switched on at the step S26, and then the process returns to the step S10. At the step S26 also, processed contents such as the ID number, the authentication result and the collated data can be outputted to the computer 10 through the communication driver 51.

[0033] Figure 8 is a flowchart to show the contents of

the registration process. The flowchart shown in fig. 7 depicts an example where data for authentication is already registered. In an actual case, however, data for authentication is registered in advance only for one or a few managers who administrate entering/leaving the room, at the initial setting stage of the organism authentication apparatus, for example, and arbitral one of those managers performs on the spot the registration process for other persons who are admitted to enter and to leave the room, as is shown in the following.

[0034] At the step S30 in Fig. 8, whether registration should be carried out or not is decided by checking whether a predetermined special ID number is inputted or not. If the result is "No", that is, if the inputted number is not the special ID number, the process goes to the step S31 where the ordinary authentication process from the step S10 to the step S26 in Fig. 7 is carried out. If the result is "Yes", then the step S32 follows.

[0035] At the step S32, authentication of the manager is first carried out. This authentication process for the manager is the same as the process from the step S12 to the step S26 in Fig. 7, except that the ID number is determined in advance in this case. Whether the authentication result for the manager is affirmative or not is decided at the step S33. If the manager is authenticated at this step, the process advances to the step S34, while if not, the process is terminated.

[0036] At the step S34, a new ID number that is to be registered is inputted by using the ten-key input board. Then, the data for authenticating the new person to be registered is inputted at the step S35. That is, steps S15 to S22 in Fig. 7 are carried out to perform recognizing the organism, obtaining a blood vessel pattern image and extracting features in the image. At the step S36, the obtained data for authenticating the person is memorized and maintained in relation to the person's ID number. Through apparatus configuration and processing steps explained heretofore, it becomes possible to authenticate an organism accurately using a small size apparatus.

[0037] Figure 6 is a front cross-section view to show the structure of the second embodiment example of the gripping portion 24. In contrast to the first embodiment example of the gripping portion where two pins are used both for fixing a hand to the proper position and for using as electrodes for organism recognition, the second embodiment example of the gripping portion uses hollows that are cut on the gripping portion 24 for fixing the hand, and uses metallic plates, metallic leaves or gills as electrodes for organism recognition.

[0038] As shown in Fig. 6, the infrared ray source board 35 is contained within the second embodiment example of the gripping portion 24. Four dents 60 corresponding to four fingers of the hand excluding the thumb are cut on the surface of the gripping portion 24. Two electrodes 61 and 62, gills for example, are formed at the bottom of two hollows corresponding to the middle finger and the third finger. A thermister 46 as a temperature sensor is

mounted at the bottom of the hollow corresponding to the forefinger. Positions of electrodes 61 and 62 and the temperature sensor 46 can be arbitrarily determined as far as they touch fingers or a hand and unless they hinder the CCD camera for capturing the blood vessel image.

THE SECOND PREFERRED EMBODIMENT EXAMPLE

[0039] The second preferred embodiment example of the invention is explained next. Figure 9 is a block diagram to show the second embodiment example of the invention. Different points from the first preferred embodiment example of the invention are; that the apparatus is divided into the control unit 70 and the authentication unit 71, that a card reader 77 is installed, that recognition of the blood vessel pattern of a finger is carried out and that the recognition mechanism works in the horizontal direction with the finger pressed against the vertical plane.

[0040] A control panel 76 with a ten-key input board and an LCD device, a card reader 77 for reading magnetic cards or IC cards and an aperture of the recognition mechanism comprising a CCD camera and infrared LEDs are comprised in the authentication unit 71.

[0041] Figure 10 (a) is a cross-sectional view of the authentication unit of the second preferred embodiment example of the organism authentication apparatus of the invention, Fig. 10 (b) is a cross-sectional view at the line A-A in the figure, Fig. 10 (c) is a B-B cross-sectional view of the common electrode 74 and Fig. 10(d) is a side view of electrodes 72 and 77.

[0042] The recognition mechanism is structured to work in the horizontal direction with the finger of a hand 14 pressed against the recognition window 75 that is vertically configured. The recognition window 75 forms a dent that is covered by the finger as shown in Fig. 10 (b). The recognition window 75 is sealed by a plate 77 that is made of materials that pass only infrared rays, such as plastics. An infrared CCD camera 91 is positioned at the left side of the recognition window 75. An infrared LED array 97 is placed at the opposite side of the recognition window 75, so that it can radiate infrared rays from the back side of the hand. By using this structure, disturbance in the captured image by wrinkles of the back of the hand can be reduced.

[0043] The LED array 97 is an array of ten infrared LEDs placed in line with 5 mm spacing, for example. In front of the LED array 97, two shielding plates 78 that provide with a gap of an appropriate value (3mm, for example) are attached. Unnecessary infrared rays are cut by these shielding plates 78, so that resolution of the obtained image can be increased.

[0044] Although apparatuses shown in Figures 9 and 10 are designed for the forefinger of the right hand as an example, the reversed configuration may be used for the left hand, or an apparatus with both structures can be used also.

[0045] Two metallic electrodes 72 and 73 that com-

pose a U-shaped finger guide as a whole and a thermister 76 that is placed between the two electrodes are positioned in front of the recognition window 75. These two electrodes 72 and 73 and the thermister 76 are designed to touch the root of the ball side of the forefinger. A common metallic electrode 74 having a dent in the middle portion of it is equipped deep inside of the recognition window 75 as shown in Fig. 10 (c). The common electrode 74 is used also as a finger guide and a finger stopper, and is designed to rise lower than the position of the nail of the finger.

[0046] By structuring the recognition mechanism to work in the horizontal direction with the finger of a hand pressed against the recognition window to cover the aperture, unnecessary infrared rays from outside can hardly enter the window, and dusts or other foreign materials can hardly stick to the window.

[0047] Figure 11 is a block diagram to show the circuit structure for each unit in the second embodiment example of the invention. An already-known one-chip computer 80 having a CPU, a ROM, a RAM, I/O ports and so on is installed in the control unit 70 in the figure. To this one-chip computer 80, an RS-232C interface circuit 82 that is used for connecting the one-chip computer 80 to another computer 10, a DIP switch 83 that is used for setting the ID and the operation mode of the organism authenticating apparatus of the invention, a timer 81, an output circuit 90 that outputs control signals for the electric lock 12 and others, a RAM 84 that stores registration information, a video capture circuit 85 that captures one frame of a video image signal through A/D conversion by video signal input circuit 80 and an RS-485 interface circuit 87 that communicates with the authentication unit 71 are connected. The computer 80 executes the registration process and the authentication process that will be explained in the following. The power supply circuit 88 provides the authentication unit with electric power.

[0048] Another already-known one-chip computer 92 having a CPU, a ROM, a RAM, analog and digital I/O ports and others is installed in the authentication unit 71 in the figure. To this one-chip computer 92, an RS-485 interface circuit 93 that is used for communicating with the other one-chip computer 80 in the control unit, a card reader 77 for magnetic cards or for IC cards, an LCD circuit 98 with a back light and a key input board 99 that are the components of the front panel, infrared LEDs 97, a temperature detection circuit 96, a resistance detection circuit 94 and a capacity detection circuit 95 are connected. The computer 92 executes various kinds of measurement processing and processing related to the panel and the card reader, under the control of the other one-chip computer 80. An already-known infrared CCD camera 91 is connected to the video input circuit 86 of the control unit 70 via a coaxial cable.

[0049] Figure 12 is a block diagram to show the structure of the resistance detection circuit 94 in the second embodiment example of the invention. The resistance detection circuit 94 provides an electric voltage to the

electrode 72 through a resistor, and measures the voltage between the electrode 72 and the common electrode 74 that varies according to the resistance of a person's finger when the finger is touched to the electrode 72 and the common electrode 74. The measured voltage at the electrode 72 is sent to the analog input terminal of the one-chip computer 92 (the input terminal of an A/D converter contained in the one-chip computer) through a buffer amplifier.

[0050] Figure 13 is a block diagram to show the structure of the temperature detection circuit 96 in the second embodiment example of the invention. The output voltage of the resistor bridge circuit containing the thermister 76 that is a temperature sensitive element as one branch of the bridge is sent to the analog input terminal of the once-chip computer 92 (the input terminal of an A/D converter contained in the one-chip computer) through a differential amplifier using an operational amplifier.

[0051] Figure 14 is a circuit diagram to show the structure of the capacity detection circuit 95 in the second embodiment example of the invention. The capacity detection circuit 95 consists mainly of an oscillation circuit that uses an already-known one-shot multi-vibrator IC. The connection point of the resistor and the capacitor that determine oscillation frequency is connected to the electrode 73. When a finger of a person touches the electrode 73 and the common electrode 74, the oscillation frequency varies according to the capacitance (and the resistance) of the finger. The oscillation signal with the rectangular waveform is sent to the digital input terminal of the one-chip computer 92, and the period (frequency) of the rectangular wave is calculated by a program in the computer.

[0052] Figure 17 shows flowcharts to explain the contents of the authentication process and the deletion process in the second embodiment example of the invention. Figure 17 (a) shows the flowchart of the authentication process. A person to be authenticated first inputs the person's ID from the panel and pushes the ENT key. The computer 80 reads the registered image, measures the DC resistance, the capacitance and the temperature and then determines whether the measured object is an organism or not by checking whether these measured values are within a predetermined range, respectively, or not. When it is determined that the object is an organism, the infrared LEDs for lighting 97 is driven by a current with the value at which LED luminosity saturates. Then the computer 80 takes in the infrared ray image data through the CCD camera 91, and turns off the infrared LEDs.

[0053] Next, the computer compresses the image data obtained (from 64KB to 1 KB, for example) and executes gradation emphasizing filtering. Figure 15 is a figure to explain the structure of the kernel pattern (weighting functions) of the gradation emphasizing filter in the second embodiment example of the invention. The filtering process is such that differential filter coefficients shown in Fig. 15 is multiplied to each of $5 \times 5 = 25$ gradation values

around the noticed pixel of the image, and the original noticed pixel value is replaced by the new value that is obtained by adding the result of the multiplication to the original noticed pixel value. Local gradation emphasizing becomes possible by this process.

[0054] Next the computer 80 removes trivial noises through noise removing filtering process, and then calculates the value of correlation between the obtained image and the registered image, in order to decide whether the person is the principal or not. In this process, a several number of correlation values are calculated by shifting the position of one of the two images, and the maximum value among the calculated values is adopted as the resultant correlation value. By this process, correct recognition becomes still possible even if the positions of the two images are mutually slipped out, by 2mm, for example. If the person is recognized as the principal, the lock is opened, and if not, a refusing action such as displaying an "NG" note is taken.

[0055] Figure 16 shows flowcharts to explain the contents of registration processes in the second embodiment example of the invention. Figure 16 (a) is a flowchart of the registration process for the administrator (only one manager that has all rights of managing the authentication system). This process is carried out when there are no registered data in the system and the function key F3 of the key board is pushed, for example. The administrator pushes the F3 key, pushes the F1 key, and then repeats three times inputting ID and inserting the administrator's hand (or finger) into the apparatus. The computer 80 calculates correlation values between the inputted data, and if those values exceed a predetermined threshold value, then the computer decides that the data is correct and stores the first inputted and processed image data as the image data of the administrator.

[0056] Figure 16 (b) is a flowchart of the registration process for a few number of managers who have limited rights of managing the authentication system. The administrator registers managers. In the manager registration process, the administrator first pushes the F3 key, inputs the administrator's ID, pushes the ENT key and makes the apparatus to authenticate the administrator's hand (or finger). Then the manager to be registered pushes the F2 key and inputs the manager's ID, and then repeats three times pushing the ENT key and inserting the manager's hand (or finger) into the apparatus. The computer 80 calculates correlation values between the inputted data, and if those values exceed a predetermined threshold value, then the computer decides that the data is correct and stores the first inputted and processed image data as the image data of the manager.

[0057] Figure 16 (c) is a flowchart of the registration process for ordinary persons who have no rights of managing the authentication system. Ordinary persons are registered by the administrator or one of managers. In the registration process, the administrator or one of managers first pushes the F3 key, inputs the ID of the administrator's or the manager's, pushes the ENT key and

makes the apparatus to authenticate the hand (or finger) of the administrator's or the manager's. Then the ordinary person to be registered inputs the person's ID, and then repeats three times pushing the ENT key and inserting the person's hand (or finger) into the apparatus. The computer 80 calculates correlation values between the inputted data, and if those values exceed a predetermined threshold value, then the computer decides that the data is correct and stores the first inputted and processed image data as the image data of the person.

[0058] Figure 17 (b) shows the flowchart to explain the contents of the deletion process in the second embodiment example of the invention. Deletion of registered data is allowed only to limited persons having special right, to the administrator, for example. In the deletion process, the administrator, for example, first pushes the F4 key, inputs the ID of the administrator's, makes the apparatus to authenticate the hand (or finger) of the administrator's and then inputs the ID to be deleted. After checking that the ID is correct on the screen displayed, the administrator pushes the ENT key if the deletion should be done. If not, the administrator pushes the CLR key to cancel deletion.

[0059] Although several embodiment examples have been shown in the explanation heretofore, other embodiment variations of the invention are possible. Blood vessel pattern image data is used for authentication in examples explained, but other authentication data such as fingerprints, voiceprints, handwritings, blood vessel patterns in the retina or iris patterns may be used in parallel for authentication or for identifying the organism.

[0060] ID numbers are inputted by using a ten-key input board in embodiment examples. But in addition to the ten-key input board, a card reader may be equipped for reading ID numbers from ID cards. Not only magnetic cards but also any of other already-known recording media can be used as a recording means for ID numbers. Otherwise, it is possible to get ID numbers through wireless connection, by installing a wireless LAN interface such as the Bluetooth interface in the organism authenticating apparatus.

[0061] Furthermore, in the second embodiment example of the invention, it is possible to use an IC card as an information recording medium in which the registered image data is stored, and to collate the registered image data read from the IC card with the image data inputted from the CCD camera for authentication. By doing this, it becomes unnecessary to store the registered image data within the authenticating apparatus.

[0062] Measurement of DC resistance, AC impedance or temperature is exemplified as a method for recognizing an organism in the embodiment examples, but in order to recognize an organism further securely, it is possible to detect the flow (movement) of blood (red blood corpuscles) through continuously capturing the enlarged blood vessel image of a hand by using another CCD camera with a close-up lens, or by adding an exchanging mechanism for the lens 31.

[0063] Methods of capturing the blood vessel pattern image by using pass-through infrared rays are explained heretofore in the embodiment examples of the invention, but it is possible to get the blood vessel image to a certain extent by using reflected rays.

[0064] Although the application to a room entrance management system is exemplified in embodiment examples of the invention, the organism authenticating apparatus of this invention can be combined with or contained in any other systems that require authentication of an individual.

FEASIBILITY OF INDUSTRIAL APPLICATIONS

[0065] By applying this invention, it becomes possible to obtain a clear blood vessel pattern image by a compact size apparatus by using an infrared ray source and by capturing the passed-through infrared ray image of the organism, and it becomes possible by using an organism recognizing means to prevent false authentication.

[0066] The organism authenticating apparatus 71 of this invention comprises a means that fixes the position of a hand or a finger of a hand, an infrared ray radiating means 97 that radiates infrared rays, an infrared ray image input means 91 that is placed at the opposite side of said hand or said finger of a hand with regard to said infrared ray radiating means, an organism recognizing means that recognizes that the organism is live, a processing means that processes data that are inputted by said infrared ray image input means so that it collates them with image data that are registered in advance and an output means that outputs the result of processing carried out by said processing means. By using this invention, it becomes possible to obtain a clear blood vessel pattern image by a compact size apparatus by using an infrared ray source and by capturing the passed-through infrared ray image of the organism, and it becomes possible by using an organism recognizing means to prevent false authentication.

Claims

1. An organism authenticating apparatus (13) comprising
 - a means adapted to fix the position of a hand or a finger of a hand,
 - an infrared ray radiating means (97) adapted to radiate infrared rays,
 - an infrared ray image input means (91) that is placed at the opposite side of said hand or said finger of a hand with regard to said infrared ray radiating means,
 - an organism recognizing means adapted to recognize that the organism is live,
 - a processing means adapted to process data that are inputted by said infrared ray image input means so that it collates them with image data that are reg-

istered in advance and an output means adapted to output the result of processing carried out by said processing means, **characterized in that**

5 said organism recognizing means is adapted to measure, in order to recognize the organism, the temperature, the resistance and the impedance at a specified frequency of the hand or the finger to be recognized, by using electrodes or a temperature sensitive element that are attached to said means that fixes the position of a hand or a finger of a hand.

2. An organism authenticating apparatus claimed in claim 1 wherein said impedance is the capacitance of the hand or the finger to be recognized.

3. An organism authenticating apparatus claimed in claim 1 wherein said infrared ray radiating means (97) and said infrared ray image input means (91) are structured so that the line connecting said infrared ray radiating means (97) and said infrared ray image input means (91) is horizontally flat.

4. An organism authenticating apparatus claimed in claim 1 wherein said processing means controls commencement of operation of said infrared ray radiating means (97) and said infrared ray image input means (91) according to the measurement result measured by said organism recognizing means.

5. An organism authenticating apparatus claimed in claim 1 wherein said infrared ray radiating means (97) comprises a plural number of infrared LEDs that are placed in line at the back side of the hand or the finger to be recognized and that are driven by a current at a level that the LED luminosity saturates and shielding means (78) that provide with a predetermined gap width between the radiating means and the hand or the finger to be recognized.

6. An organism authenticating apparatus claimed in claim 1 wherein said organism authenticating apparatus contains a reading means that reads registered image data that is stored in an information recording medium, and said processing means collates image data that are inputted by said infrared ray image input means (91) and that are processed by said processing means to image data that are read by said reading means.

Patentansprüche

1. Organismus-Authentifizierungsvorrichtung (13), mit:

einer Einrichtung, die zum Fixieren der Position einer Hand oder eines Fingers einer Hand an-

- gepasst ist,
 einer Infrarotstrahl-Ausstrahlungseinrichtung (97), die zum Ausstrahlen von Infrarotstrahlen angepasst ist,
 einer Infrarotstrahl-Bildeingabeeinrichtung (91), die an der gegenüberliegenden Seite der Hand oder des Fingers einer Hand mit Bezug auf die Infrarotstrahl-Ausstrahlungseinrichtung angeordnet ist,
 einer Organismus-Erkennungseinrichtung, die zum Erkennen, dass der Organismus lebendig ist, angepasst ist,
 einer Verarbeitungseinrichtung, die zum Verarbeiten von Daten, die durch die Infrarotstrahl-Bildeingabeeinrichtung eingegeben werden, so dass sie diese mit im Voraus registrierten Bilddaten zusammenträgt, angepasst ist, und einer Ausgabereinrichtung, die zum Ausgeben des Ergebnisses einer durch die Verarbeitungseinrichtung ausgeführten Verarbeitung angepasst ist,
- dadurch gekennzeichnet, dass**
 die Organismus-Erkennungseinrichtung zum Messen der Temperatur, des Widerstands und der Impedanz bei einer spezifizierten Frequenz der zu untersuchenden Hand oder des zu untersuchenden Fingers angepasst ist, um den Organismus zu erkennen, unter Verwendung von Elektroden oder einem temperatursensitiven Bauelement, die an der die Position einer Hand oder eines Fingers einer Hand fixierenden Einrichtung angebracht sind.
2. Organismus-Authentifizierungsvorrichtung gemäß Anspruch 1, wobei die Impedanz die Kapazität der zu erkennenden Hand oder des zu erkennenden Fingers darstellt.
 3. Organismus-Authentifizierungsvorrichtung gemäß Anspruch 1, wobei die Infrarotstrahl-Ausstrahlungseinrichtung (97) und die Infrarotstrahl-Bildeingabeeinrichtung (91) so aufgebaut sind, dass die Infrarotstrahl-Ausstrahlungseinrichtung (97) und die Infrarotstrahl-Bildeingabeeinrichtung (91) horizontal flach in Verbindung stehen.
 4. Organismus-Authentifizierungsvorrichtung gemäß Anspruch 1, wobei die Verarbeitungseinrichtung einen Betriebsbeginn der Infrarotstrahl-Ausstrahlungseinrichtung (97) und der Infrarotstrahl-Bildeingabeeinrichtung (91) gemäß dem durch die Organismus-Erkennungseinrichtung gemessenen Messergebnis steuert.
 5. Organismus-Authentifizierungsvorrichtung gemäß Anspruch 1, wobei die Infrarotstrahl-Ausstrahlungseinrichtung (97) eine Vielzahl von Infrarot-LEDs, die in Reihe an der Rückseite der zu erkennenden Hand

oder des zu erkennenden Fingers angeordnet ist, und die durch einen Strom mit einem Niveau betrieben wird, dass die LED-Leuchstärke gesättigt ist, und eine Abschirmeinrichtung (78) aufweist, die mit einer vorbestimmten Spaltbreite zwischen der Ausstrahlungseinrichtung und der zu erkennenden Hand oder dem zu erkennenden Finger bereitgestellt ist.

6. Organismus-Authentifizierungsvorrichtung gemäß Anspruch 1, wobei die Organismus-Authentifizierungsvorrichtung eine Leseeinrichtung enthält, die in einem Informationsaufnahmemedium gespeicherte registrierte Bilddaten liest, und die Verarbeitungseinrichtung Bilddaten zusammenträgt, die durch die Infrarotstrahl-Bildeingabeeinrichtung (91) eingegeben werden, und die durch die Verarbeitungseinrichtung zu Bilddaten verarbeitet werden, die durch die Leseeinrichtung gelesen werden.

Revendications

1. Appareil d'authentification d'organisme (13) comprenant
 un moyen adapté pour fixer la position d'une main ou d'un doigt d'une main,
 un moyen de rayonnement de rayons infrarouges (97) adapté pour rayonner des rayons infrarouges,
 un moyen d'introduction d'image aux rayons infrarouges (91) qui est placé au côté opposé de ladite main ou dudit doigt d'une main par rapport audit moyen de rayonnement de rayons infrarouges,
 un moyen de reconnaissance d'organisme adapté pour reconnaître que l'organisme est vivant,
 un moyen de traitement adapté pour traiter des données qui sont introduites par ledit moyen d'introduction d'image aux rayons infrarouges de sorte à les réunir avec des données d'image qui sont enregistrées au préalable et
 un moyen de sortie adapté pour délivrer en sortie le résultat de traitement effectué par ledit moyen de traitement,
caractérisé en ce que
 ledit moyen de reconnaissance d'organisme est adapté pour mesurer la température, la résistance et l'impédance à une fréquence spécifiée de la main ou du doigt à reconnaître, afin de reconnaître l'organisme, en utilisant des électrodes ou un élément sensible à la température qui sont attachés audit moyen qui fixe la position d'une main ou d'un doigt d'une main.
2. Appareil d'authentification d'organisme revendiqué dans la revendication 1 dans lequel ladite impédance est la capacité de la main ou du doigt à reconnaître.
3. Appareil d'authentification d'organisme revendiqué

dans la revendication 1 dans lequel ledit moyen de rayonnement de rayons infrarouges (97) et ledit moyen d'introduction d'image aux rayons infrarouges (91) sont structurés de sorte que la ligne reliant ledit moyen de rayonnement de rayons infrarouges (97) et ledit moyen d'introduction d'image aux rayons infrarouges (91) soit horizontalement plate. 5

4. Appareil d'authentification d'organisme revendiqué dans la revendication 1 dans lequel ledit moyen de traitement commande le début du fonctionnement dudit moyen de rayonnement de rayons infrarouges (97) et dudit moyen d'introduction d'image aux rayons infrarouges (91) selon le résultat de mesure mesuré par ledit moyen de reconnaissance d'organisme. 10 15
5. Appareil d'authentification d'organisme revendiqué dans la revendication 1 dans lequel ledit moyen de rayonnement de rayons infrarouges (97) comprend plusieurs diodes électroluminescentes infrarouges qui sont placées en ligne sur le côté arrière de la main ou du doigt à reconnaître et qui sont commandées par un courant électrique à un niveau auquel la luminosité des diodes électroluminescentes est saturée et des moyens de protection (78) qui fournissent une largeur de jeu prédéterminée entre le moyen de rayonnement et la main ou le doigt à reconnaître. 20 25 30
6. Appareil d'authentification d'organisme revendiqué dans la revendication 1 dans lequel ledit appareil d'authentification d'organisme contient un moyen de lecture qui lit des données d'image enregistrées qui sont stockées dans un support d'enregistrement d'informations, et ledit moyen de traitement réunit des données d'image qui sont introduites par ledit moyen d'introduction d'image aux rayons infrarouges (91) et qui sont traitées par ledit moyen de traitement aux données d'image qui sont lues par ledit moyen de lecture. 35 40

45

50

55

Fig. 1

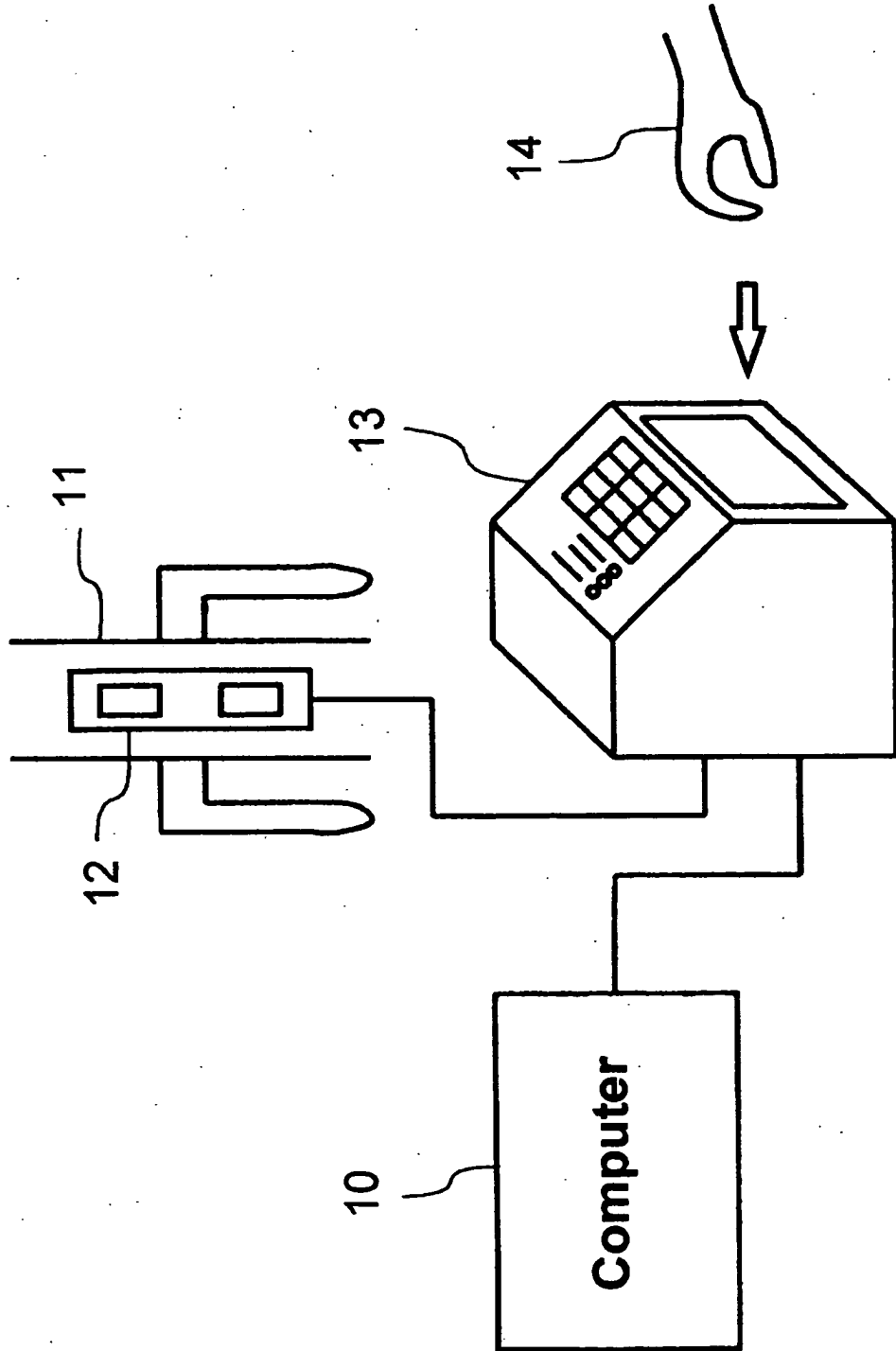

Fig. 2

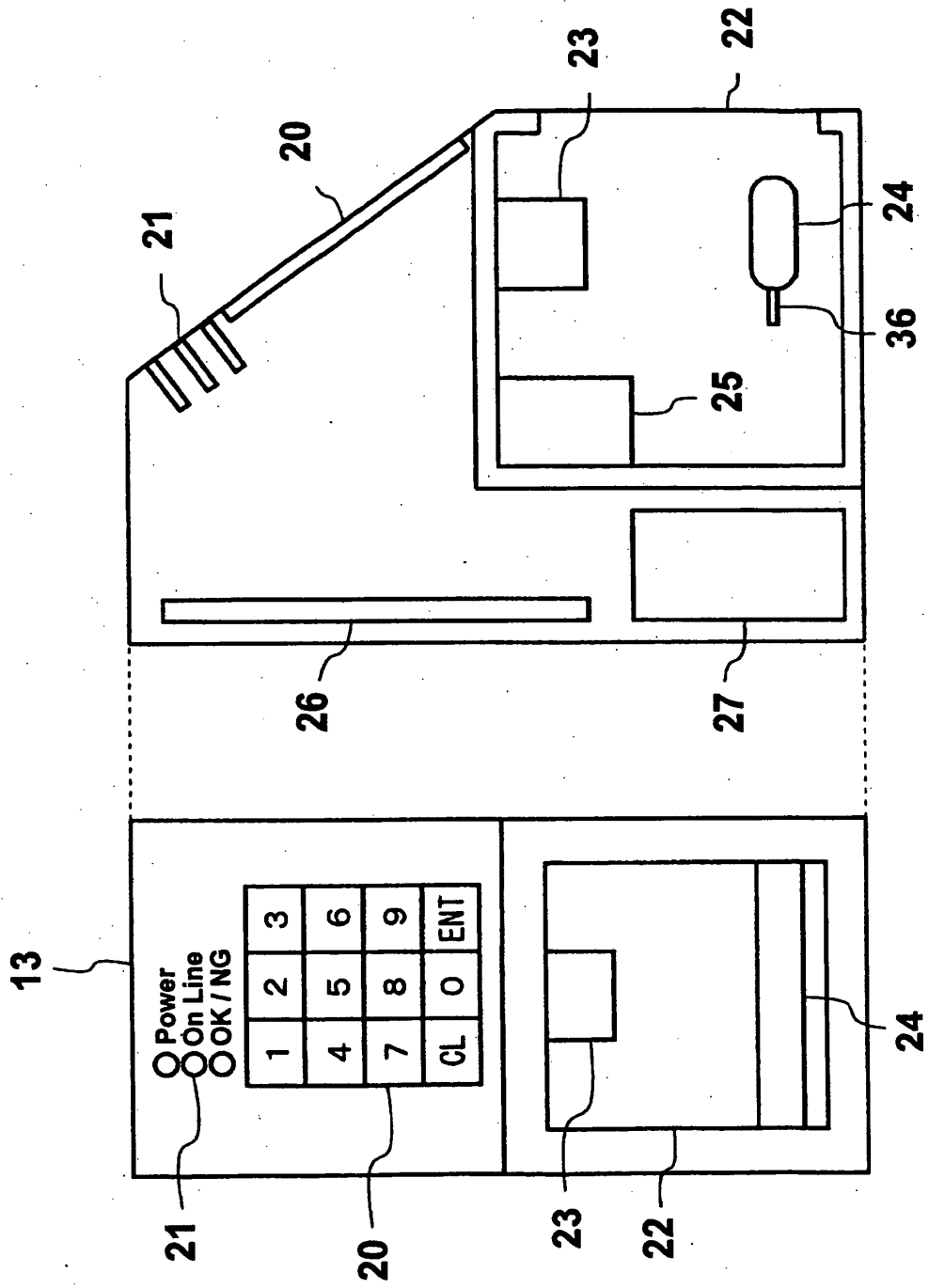

Fig. 3

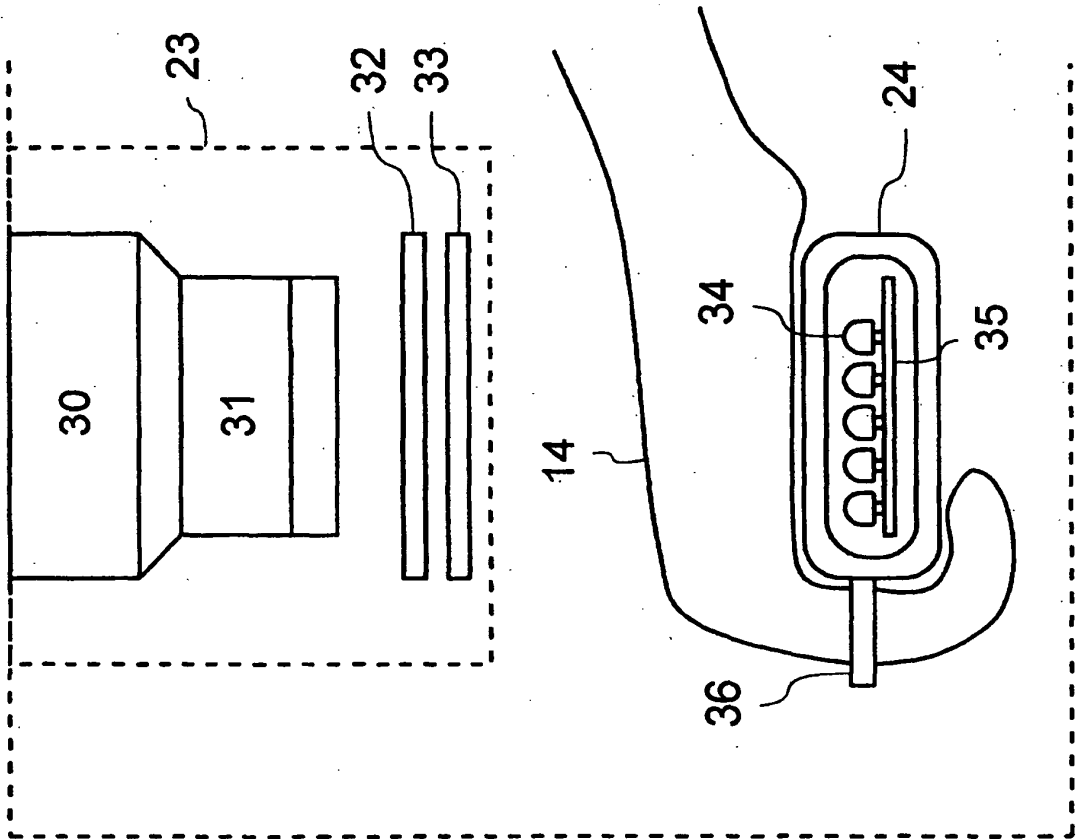

Fig. 4

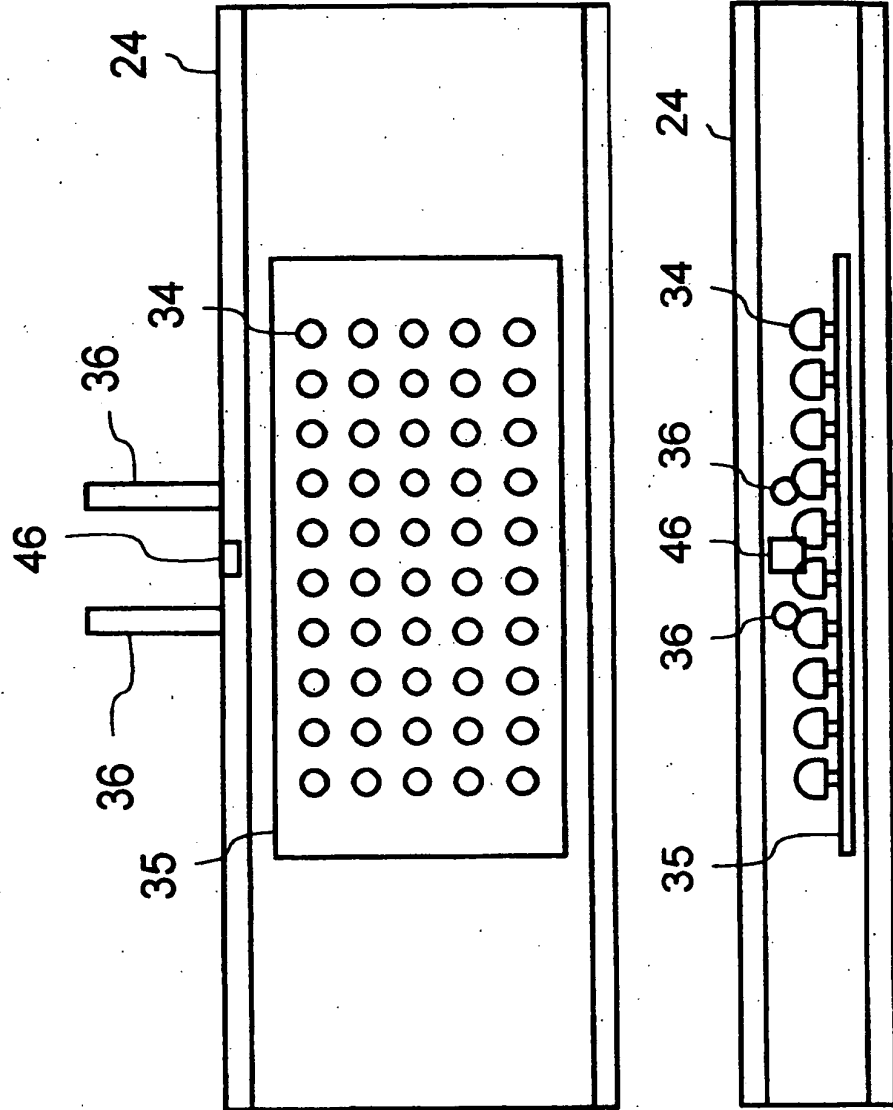

Fig. 5

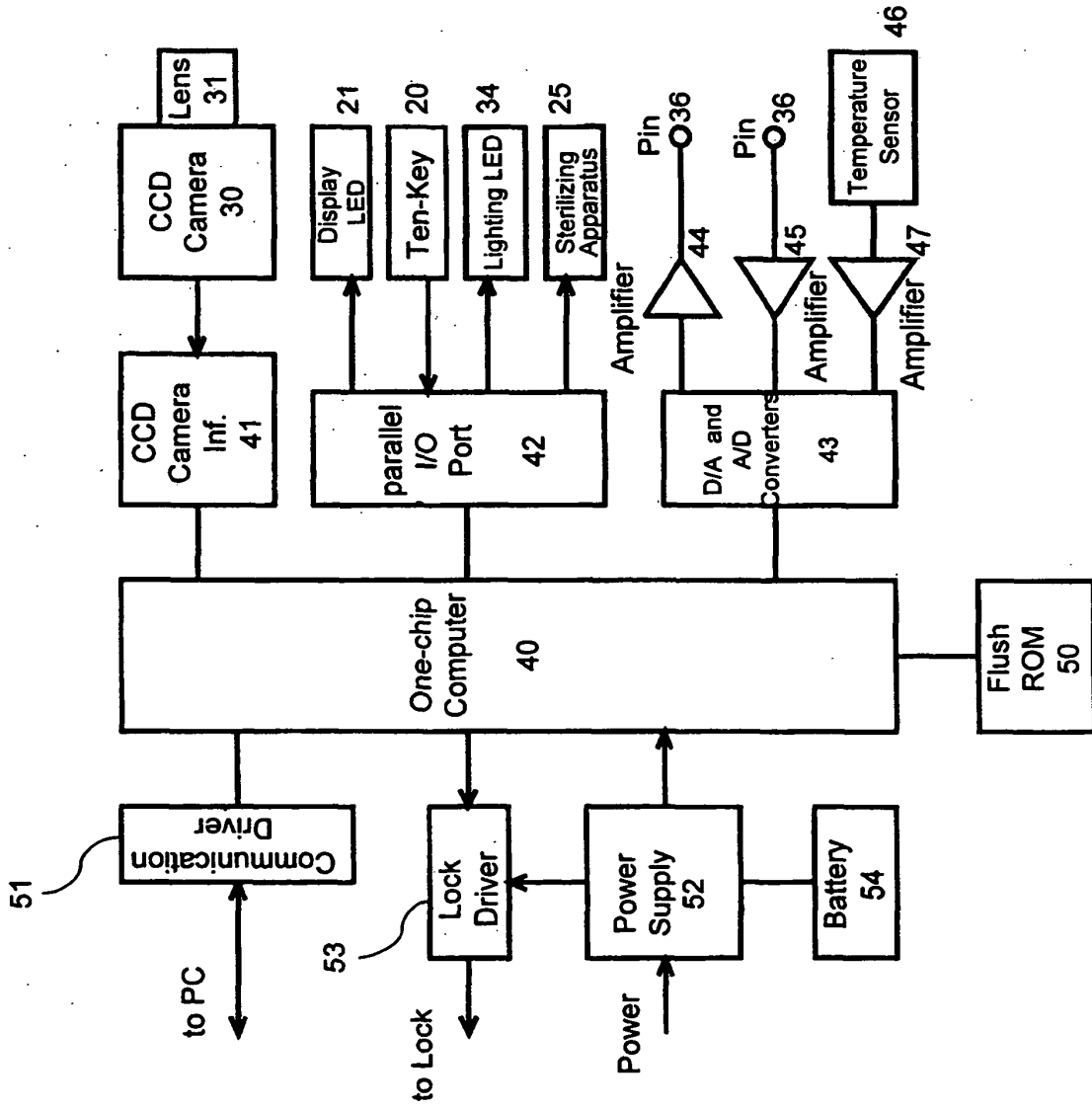

Fig. 6

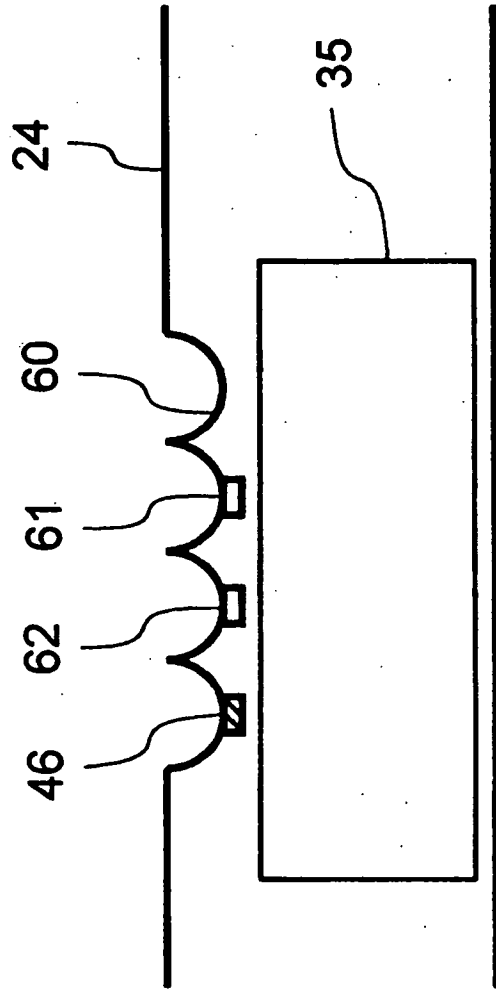

Fig. 7

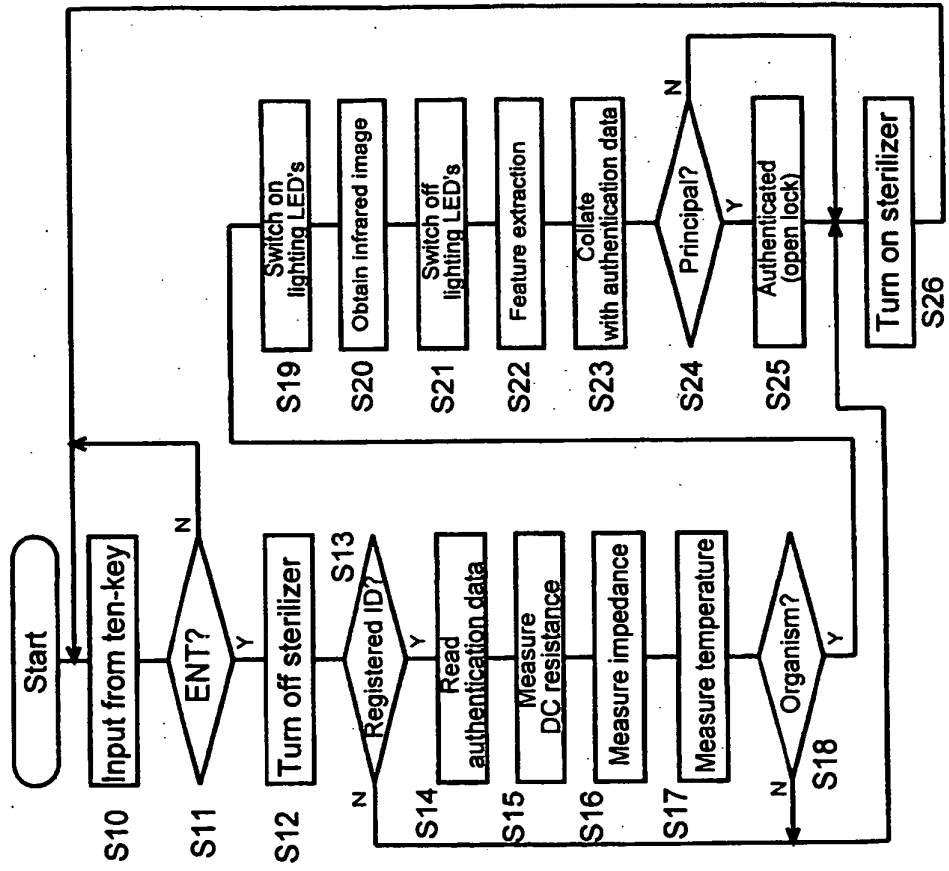

Fig. 8

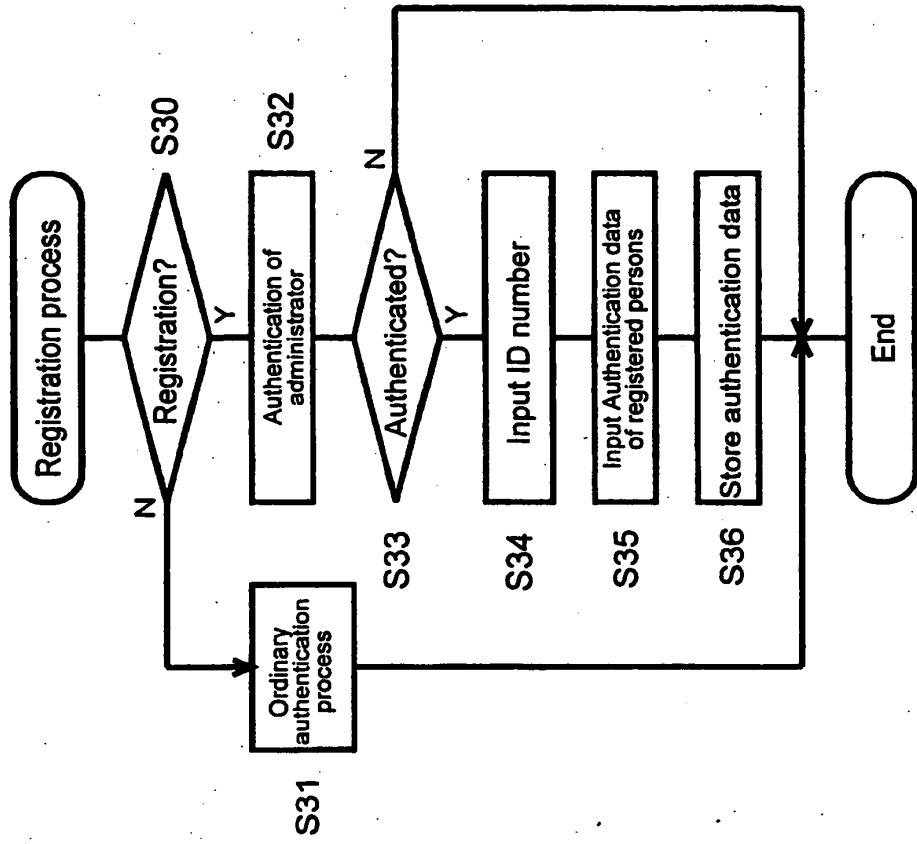

Fig. 9

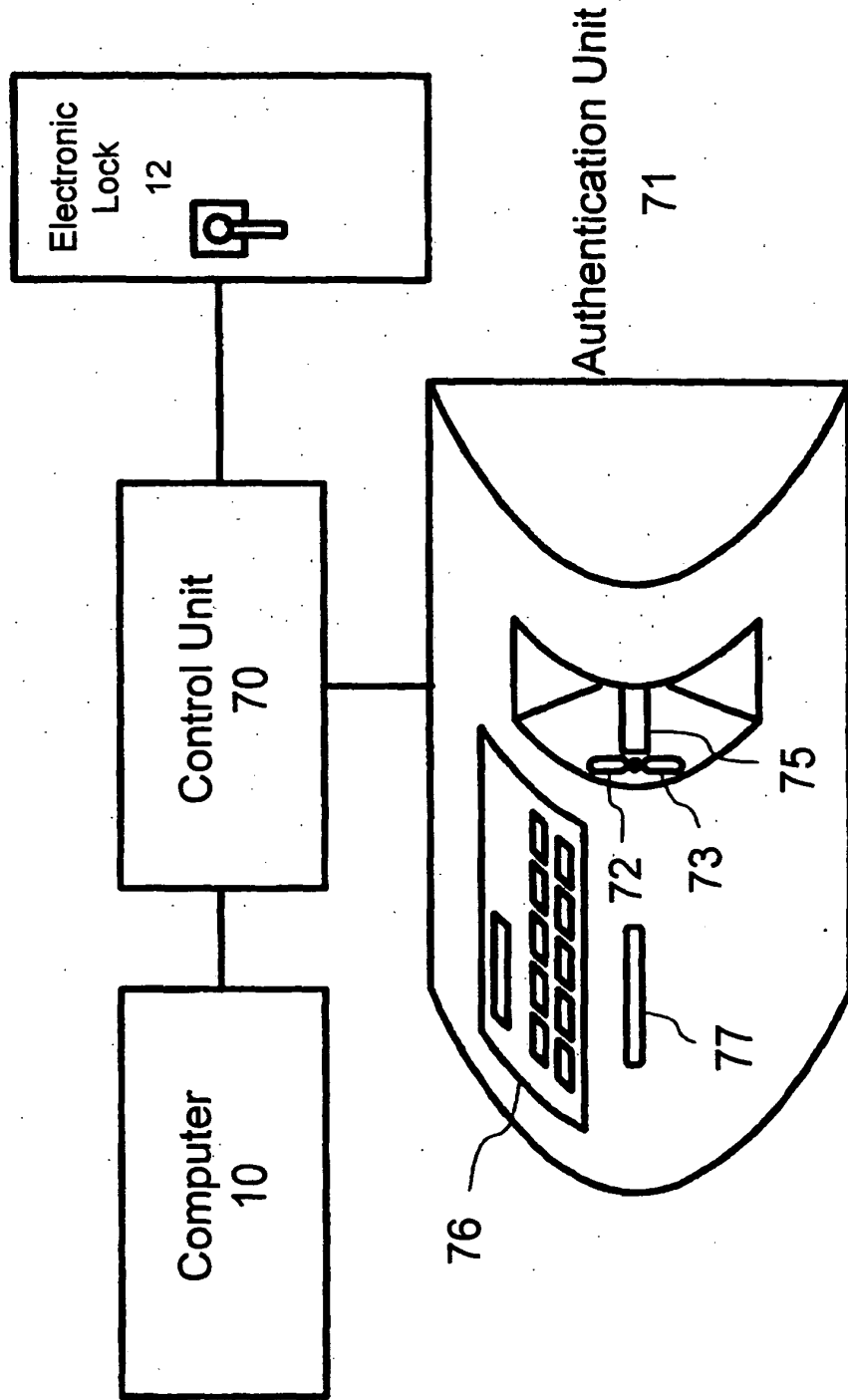

Fig. 10

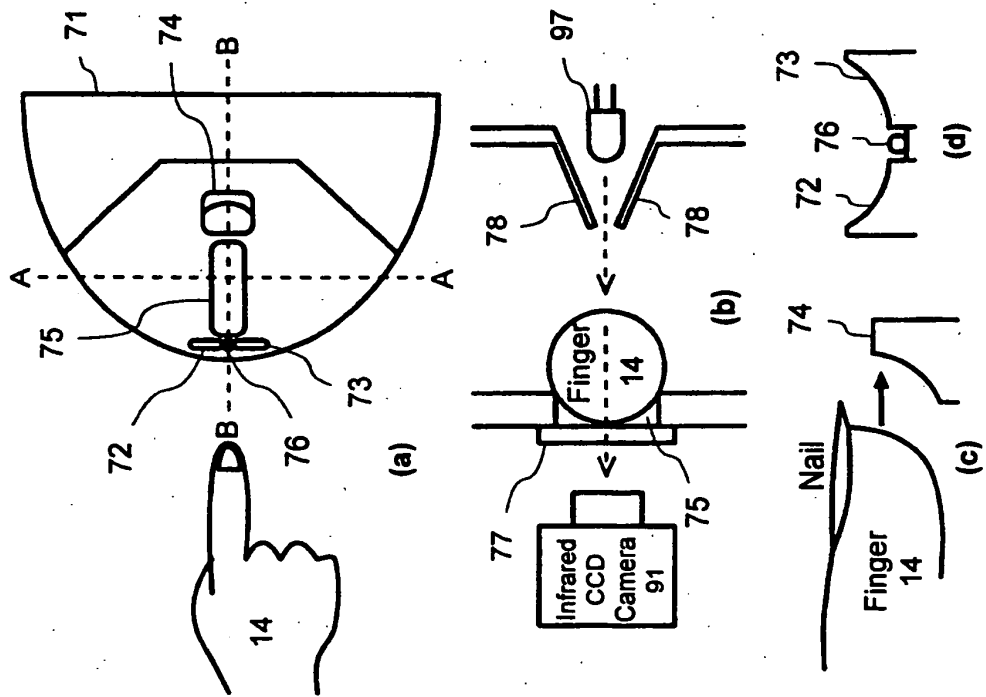

Fig. 11

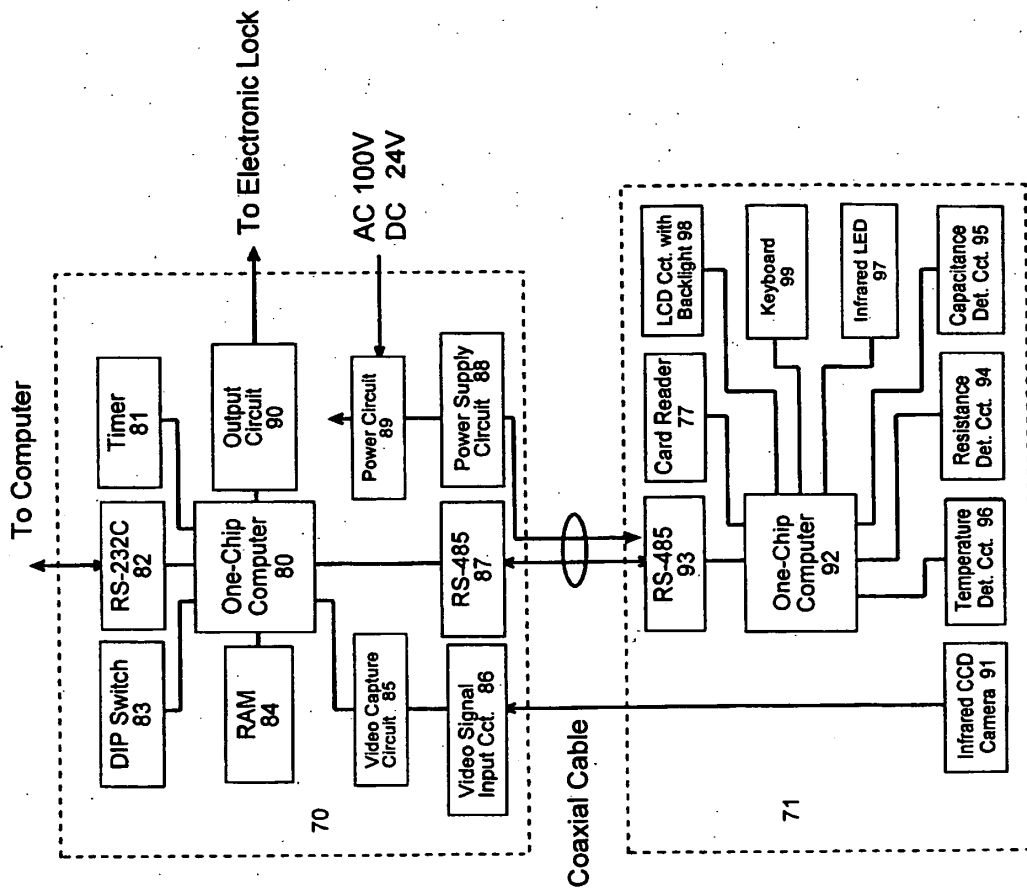

Fig. 12

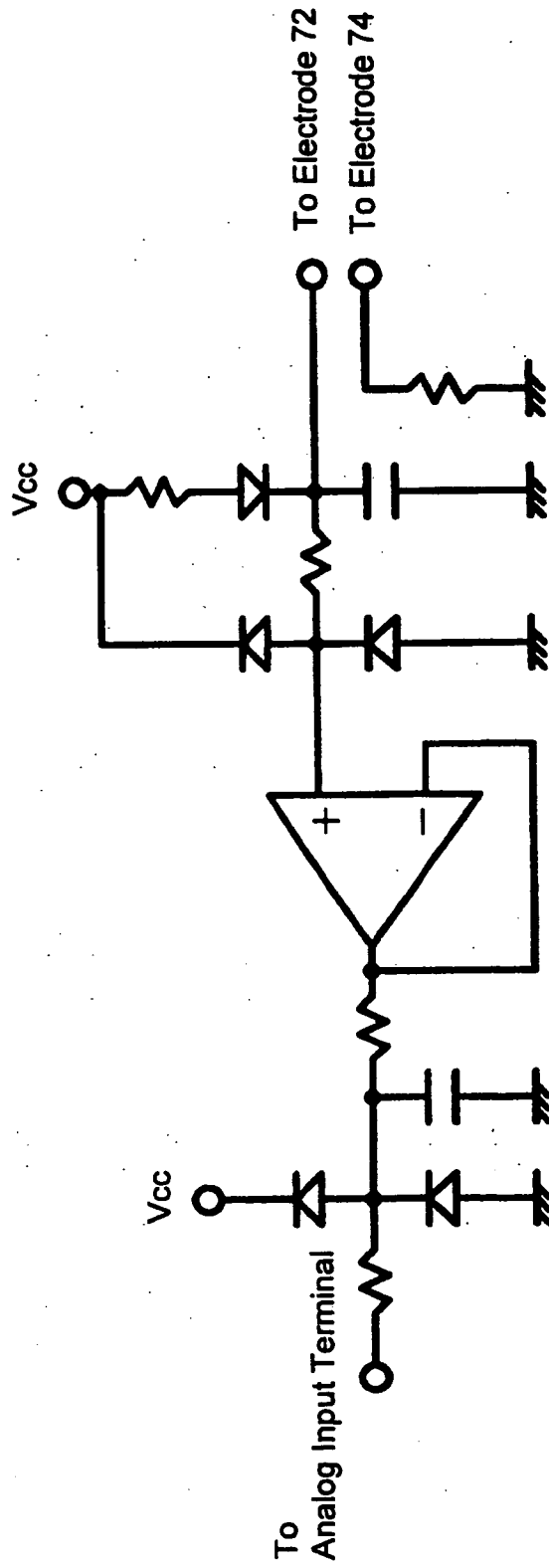

Fig. 13

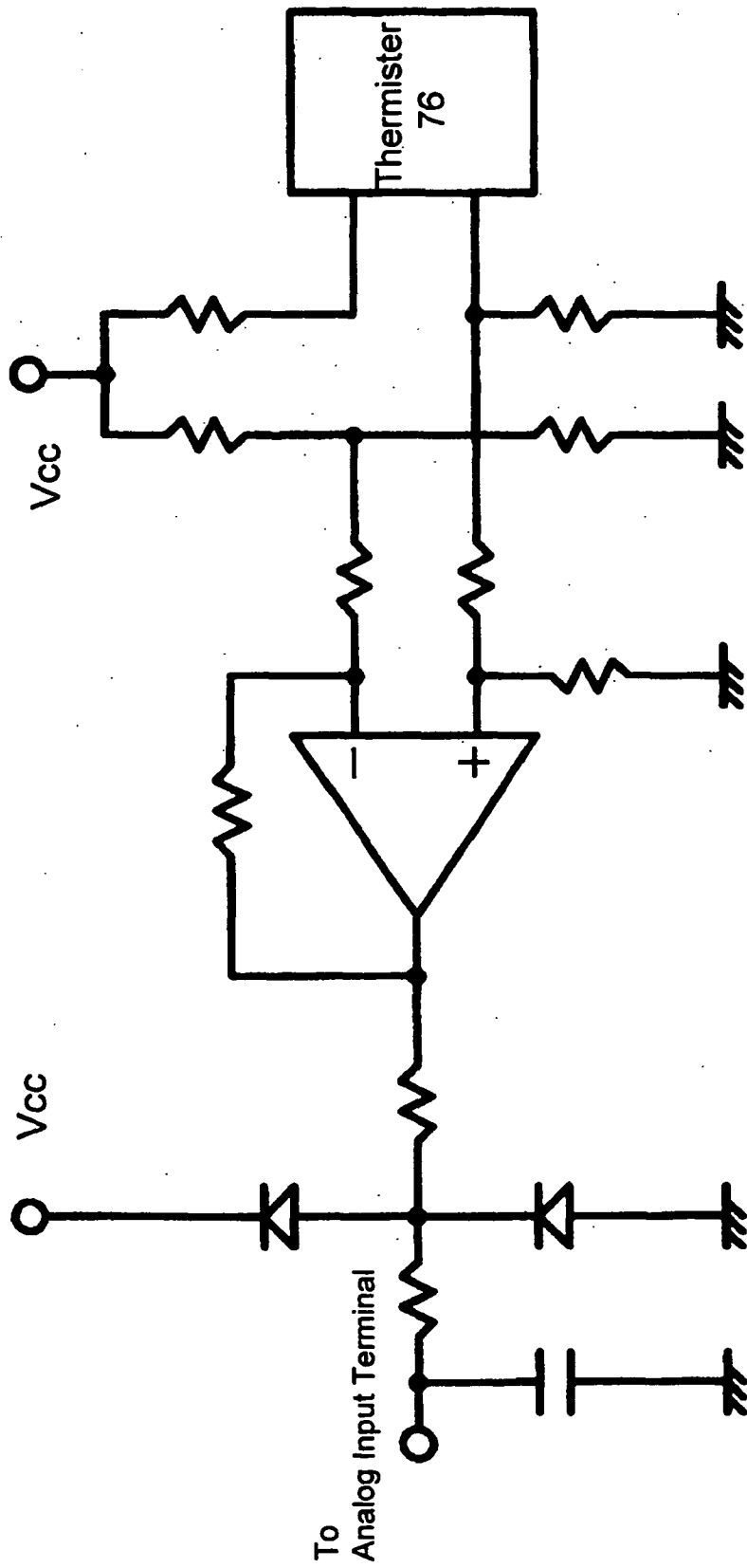

Fig. 14

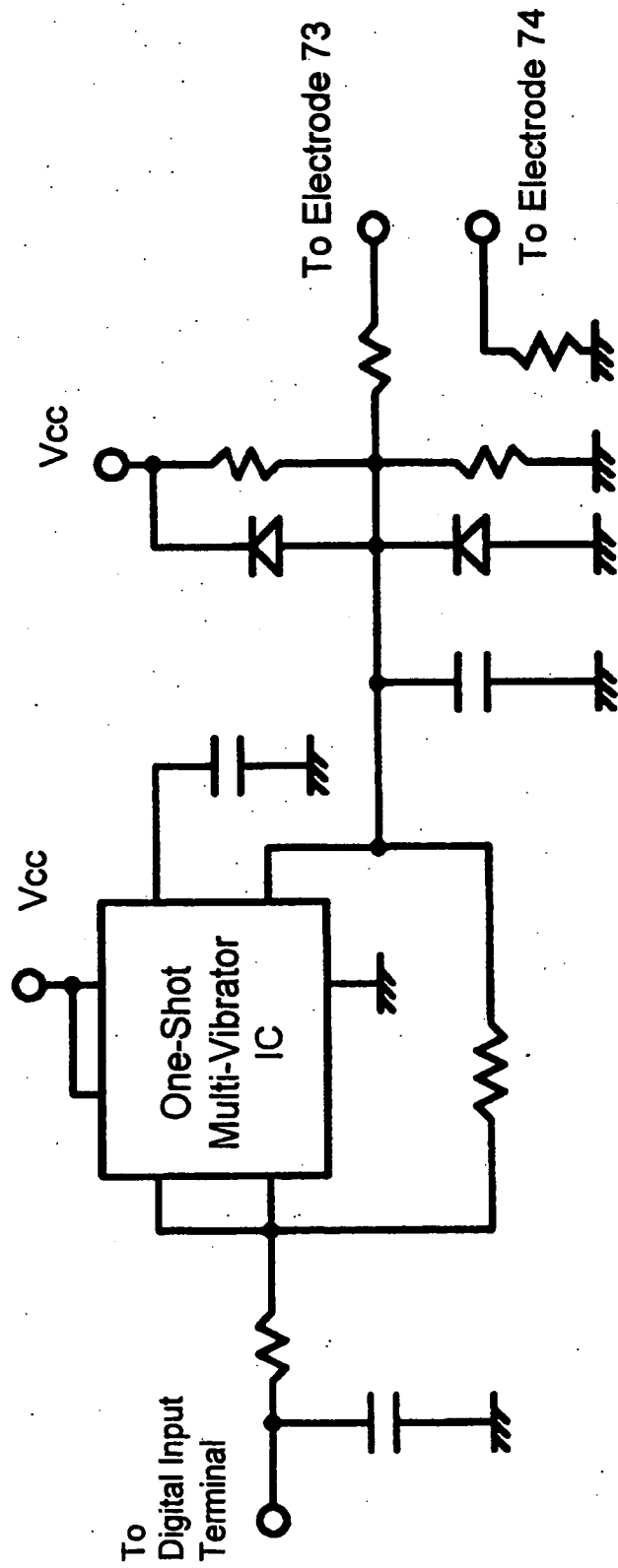

Fig. 15

0	-1	-1	-1	0
-1	0	2	0	-1
-1	2	5	2	-1
-1	0	2	0	-1
0	-1	-1	-1	0

Fig. 16

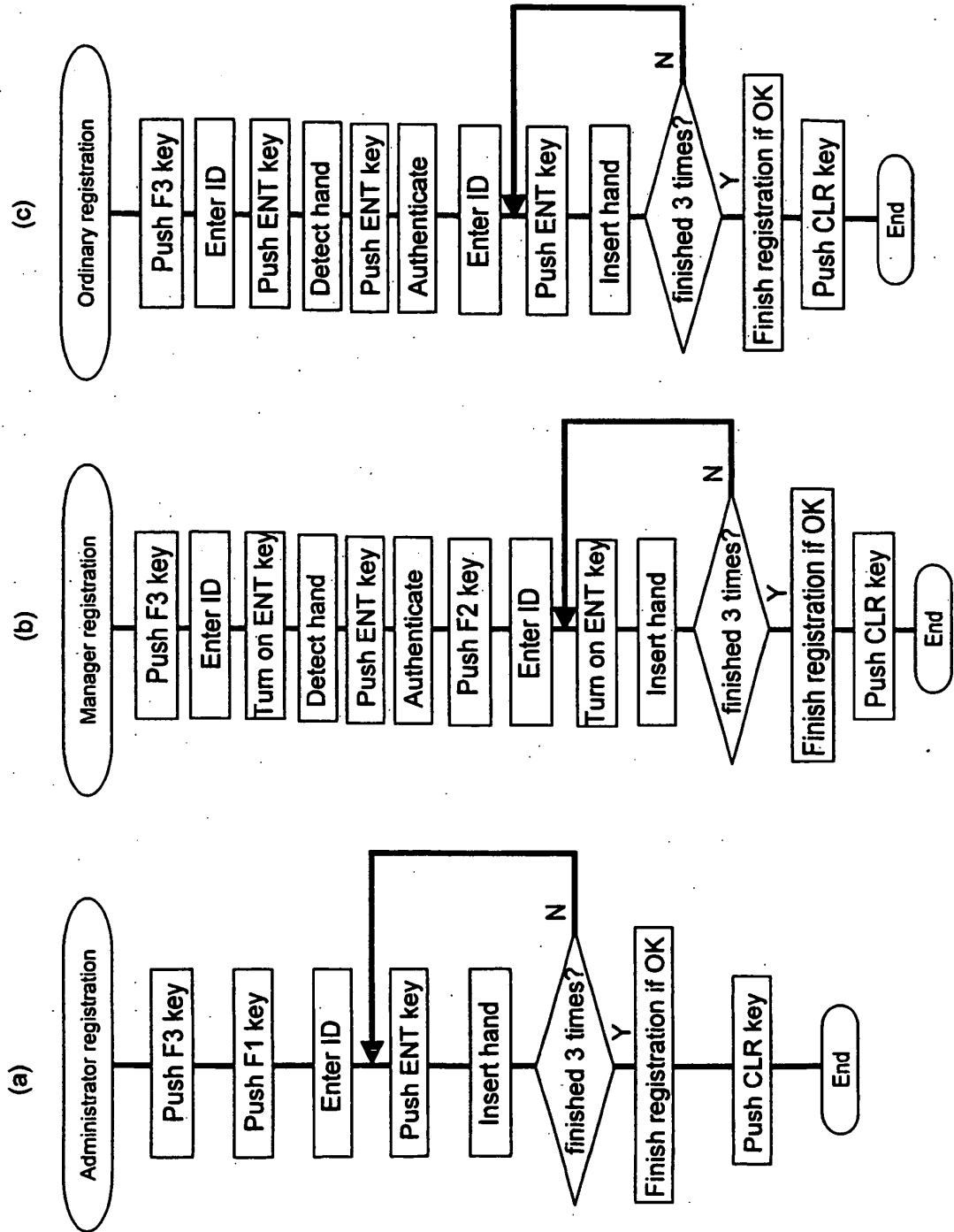
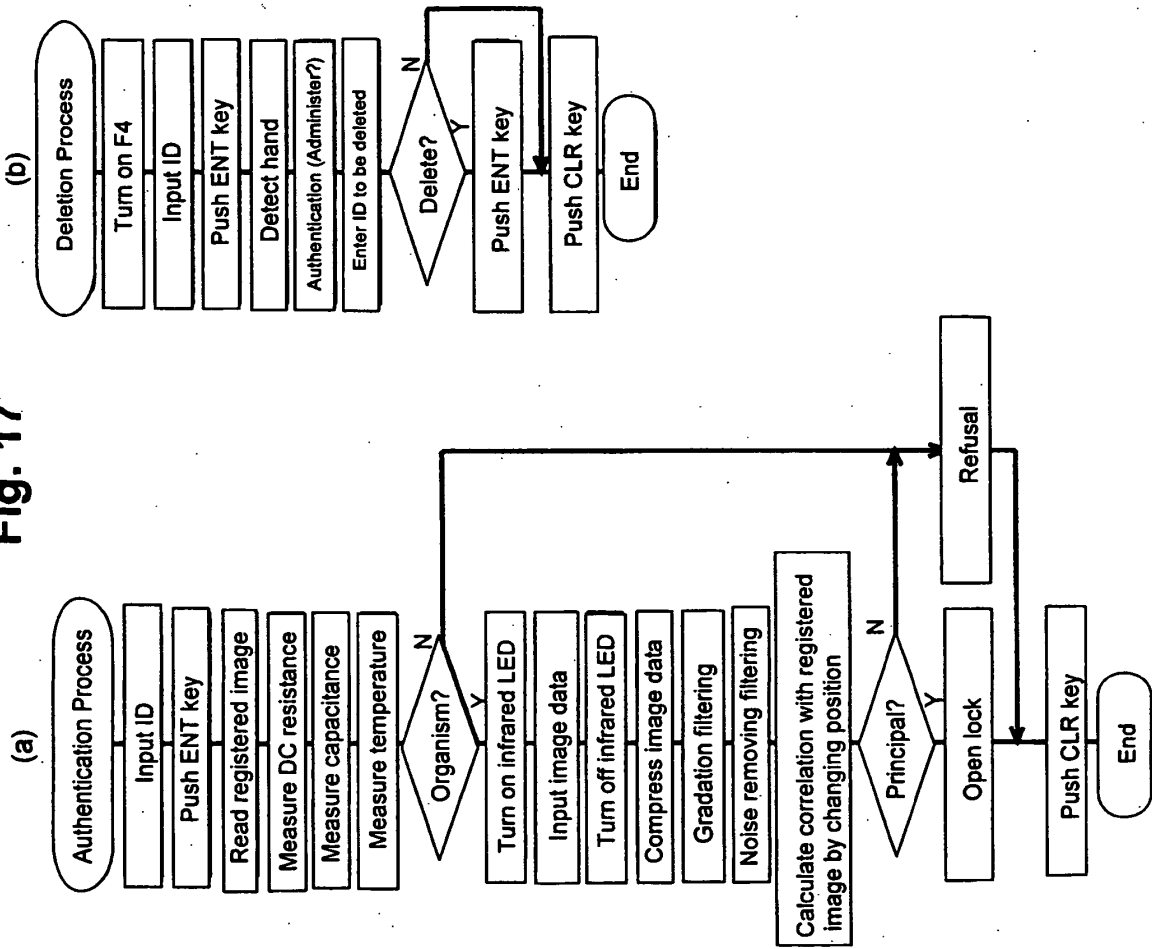

Fig. 17



REFERENCES CITED IN THE DESCRIPTION

This list of references cited by the applicant is for the reader's convenience only. It does not form part of the European patent document. Even though great care has been taken in compiling the references, errors or omissions cannot be excluded and the EPO disclaims all liability in this regard.

Patent documents cited in the description

- JP H08508419 A [0002]
- JP 10127609 B [0003]
- JP 11203452 B [0004]

专利名称(译)	生物鉴定仪器		
公开(公告)号	EP1376465B1	公开(公告)日	2009-04-15
申请号	EP2002700728	申请日	2002-02-25
申请(专利权)人(译)	仿生CO., LTD.		
当前申请(专利权)人(译)	仿生CO., LTD.		
[标]发明人	CHOSHI KINYA BIONICS CO LTD KANEDA YUSUKE BIONICS CO LTD		
发明人	CHOSHI, KINYA, BIONICS CO., LTD. KANEDA, YUSUKE, BIONICS CO., LTD.		
IPC分类号	G06T1/00 A61B5/117 A61B5/00 G01J1/42 G01V8/10 G06F15/00 G06F21/20 G06K9/00 G06T7/00 H04L9/32		
CPC分类号	G06K9/00 A61B5/0059 A61B5/015 A61B5/1171 A61B5/489 A61B5/6825 A61B5/6826 A61B5/6838 G06K9/00885 G06K2009/00932		
代理机构(译)	TBK专利		
优先权	2001049823 2001-02-26 JP 2001204314 2001-07-05 JP		
其他公开文献	EP1376465A4 EP1376465A1		
外部链接	Espacenet		

摘要(译)

本发明的生物体认证装置71包括固定手或手指的位置的装置，发射红外线的红外线辐射装置97，位于相对侧的红外线图像输入装置91关于所述红外线辐射装置的所述手或所述手指的手指，识别所述生物是活的生物体识别装置，处理由所述红外线图像输入装置输入的数据以使其整理的处理装置它们具有预先登记的图像数据和输出装置，输出装置输出由所述处理装置执行的处理结果。通过使用本发明，可以通过使用红外线源并通过捕获生物体的穿过的红外线图像，通过紧凑尺寸设备获得清晰的血管图案图像，并且可以通过使用生物体识别来获得意味着防止错误认证。

