



(51) International Patent Classification:

A61M 39/02 (2006.01) H01R 13/52 (2006.01)  
A61M 1/12 (2006.01) H01R 13/62 (2006.01)  
A61B 5/00 (2006.01)

(21) International Application Number:

PCT/US2015/035657

(22) International Filing Date:

12 June 2015 (12.06.2015)

(25) Filing Language:

English

(26) Publication Language:

English

(30) Priority Data:

62/011,290 12 June 2014 (12.06.2014) US  
62/097,304 29 December 2014 (29.12.2014) US

(71) Applicant: HEARTWARE, INC. [US/US]; 14420 NW  
60th Avenue, Miami Lakes, FL 33014 (US).

(72) Inventors: ANDRUS, Lance Lynn; 12 Sarsenstone Way,  
Southborough, MA 01772 (US). CASTILLO, Andre;  
1800 NE 29th Avenue, Apt. 907, Aventura, FL 33180  
(US).

(74) Agents: MILANO, Mario et al.; Lerner, David, Litten-  
berg, Krumholz & Mentlik, LLP, 600 South Avenue West,  
Westfield, New Jersey 07090 (US).

(81) Designated States (unless otherwise indicated, for every

kind of national protection available): AE, AG, AL, AM, AO, AT, AU, AZ, BA, BB, BG, BH, BN, BR, BW, BY, BZ, CA, CH, CL, CN, CO, CR, CU, CZ, DE, DK, DM, DO, DZ, EC, EE, EG, ES, FI, GB, GD, GE, GH, GM, GT, HN, HR, HU, ID, IL, IN, IR, IS, JP, KE, KG, KN, KP, KR, KZ, LA, LC, LK, LR, LS, LU, LY, MA, MD, ME, MG, MK, MN, MW, MX, MY, MZ, NA, NG, NI, NO, NZ, OM, PA, PE, PG, PH, PL, PT, QA, RO, RS, RU, RW, SA, SC, SD, SE, SG, SK, SL, SM, ST, SV, SY, TH, TJ, TM, TN, TR, TT, TZ, UA, UG, US, UZ, VC, VN, ZA, ZM, ZW.

(84) Designated States (unless otherwise indicated, for every

kind of regional protection available): ARIPO (BW, GH, GM, KE, LR, LS, MW, MZ, NA, RW, SD, SL, ST, SZ, TZ, UG, ZM, ZW), Eurasian (AM, AZ, BY, KG, KZ, RU, TJ, TM), European (AL, AT, BE, BG, CH, CY, CZ, DE, DK, EE, ES, FI, FR, GB, GR, HR, HU, IE, IS, IT, LT, LU, LV, MC, MK, MT, NL, NO, PL, PT, RO, RS, SE, SI, SK, SM, TR), OAPI (BF, BJ, CF, CG, CI, CM, GA, GN, GQ, GW, KM, ML, MR, NE, SN, TD, TG).

Published:

— with international search report (Art. 21(3))

(54) Title: PERCUTANEOUS CONNECTOR WITH MAGNETIC CAP AND ASSOCIATED METHODS OF USE

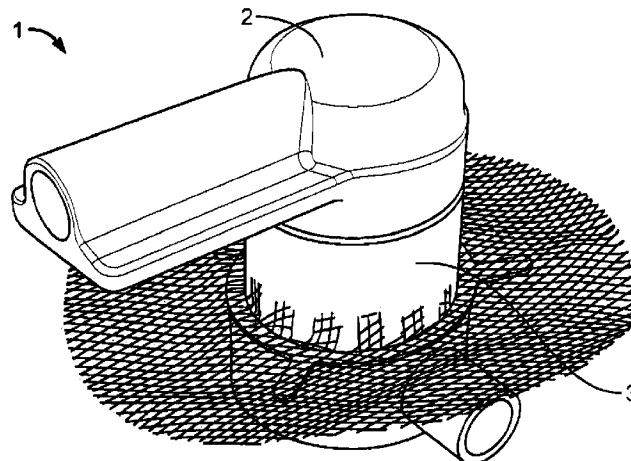

FIG. 1

(57) Abstract: In one embodiment, the present invention includes a percutaneous skin connector 1 including a base 3 and a cap 2. The base 3 has a channel 31 extending through it and a plurality of base magnets 24, 29 are positioned around the channel 31 and exposed at a base surface 30. A skirt 21 which allows tissue ingrowth extends from the base 3 to further secure the base 3 to the patient. The connector 1 also includes a cap 2 with a bore 61 extending through it and a plurality of cap magnets 47, 48 positioned around the bore 61 and exposed at a cap surface 42. The base magnets 24, 29 and cap magnets 47, 48 attract and align the cap surface 42 to the base surface 30. The connector 1 further includes a release mechanism adapted to at least partially separate the cap 2 from the base 3 when the cap 2 is rotated relative to the base 3 and out of alignment with the base 3.

## PERCUTANEOUS CONNECTOR WITH MAGNETIC CAP AND ASSOCIATED METHODS OF USE

## CROSS-REFERENCE TO RELATED APPLICATIONS

**[0001]** This application claims the benefit of the filing date of U.S. Patent Application No. 62/011,290, filed June 12, 2014, and U.S. Patent Application No. 62/097,304 filed December 29, 2014, the disclosures of which are hereby incorporated herein by reference.

## BACKGROUND OF THE INVENTION

**[0002]** The present invention relates to an improved device and method for connecting a device implanted inside the body of a patient to an external controller.

**[0003]** Thousands of heart patients who suffer from severe ventricular heart failure could benefit from cardiac transplantation. However, because of a shortage of donor hearts, most of these patients have a shortened life span characterized by frequent hospitalizations, severe physical disability, and death from congestive failure or cardiogenic shock, and do not survive long enough for a donor heart to become available.

**[0004]** One medical device developed to aid these heart patients is a heart pump such as a ventricular assist device ("VAD") which enables heart patients to return to prolonged and productive lives. Heart pumps are typically implanted in the patient and are connected to the left ventricle of the heart. One end of a tube such as a graft is connected to the heart pump and the other end is connected to the ascending aorta or the descending aorta. Once connected, the heart pump pumps blood from the left ventricle to the ascending or descending aorta to improve blood flow.

**[0005]** Most VADs utilize an external controller and power source. An electrical connection must therefore be established across the boundary of a patient's skin between the internal pump and external controller. A typical way to provide this connection is through the use of a percutaneous

connector which provides an access way into the patient's body to establish the connection.

**[0006]** Traditional percutaneous connectors include an internal portion and an external portion. The internal portion is implanted into the body and extends through the patient's skin. The external portion attaches to the internal portion to establish the electrical connection. The connection between the two portions must be strong enough to maintain the connection during normal use, but not so strong as to cause patient discomfort when disconnecting the portions. A detachable connector must also be properly aligned to ensure the correct electrical connection is established.

**[0007]** Accordingly, there is a need for an improved connector which securely establishes an electrical connection between an internal device and external controller and which provides a detachable connection which minimizes patient discomfort when releasing the connection.

#### BRIEF SUMMARY OF THE INVENTION

**[0008]** A percutaneous connector according to one aspect of the disclosure preferably includes a base having a base surface; one or more base magnets within the base defining a plurality of magnetic poles adjacent the base surface; a mating connector or cap having a cap surface; one or more cap magnets within the cap defining a plurality of magnetic poles adjacent the cap surface; the base magnets and cap magnets attract and align the cap and base with the cap surface and the base surface confronting one another; and a release mechanism adapted to at least partially separate the cap from the base when the cap is rotated relative to the base and out of alignment with the base.

**[0009]** The percutaneous connector may also include a skirt extending from the base. In one embodiment, the base magnets and cap magnets can each have their respective polar axes extending perpendicularly to the base surface and cap surface. At least one of the one or more base magnets may

define at least one north pole and at least one south pole adjacent the base surface and at least one of the one or more cap magnets can define at least one north pole and at least one south pole adjacent to the cap surface. Further, at least one of the base magnets can have a polarity adjacent to the base surface opposite to the polarity of the other base magnets and at least one of the cap magnets can have a polarity adjacent to the cap surface opposite to the polarity of the other cap magnets. The plurality of poles defined by the base magnets and the cap magnets may be equally spaced such that each base magnet pole aligns with a cap magnet pole. The base and cap can have an unequal number of magnets to allow different orientations of the cap with respect to the base.

**[0010]** One aspect of the percutaneous connector according to the disclosure may allow rotation of the cap with respect to the base to misalign the cap and base magnets to reduce the magnetic attraction between the cap and base. Further rotation of the cap with respect to the base can cause magnetic repulsion between the cap magnets and base magnets. Such rotation may make release of the cap from the base easier for the patient, thereby reducing patient discomfort during release.

**[0011]** The release mechanism may include at least one cam formed at an oblique angle to the surface of one of the cap and base and at least one mating structure adapted to engage the at least one cam formed on the other of the cap and base.

**[0012]** The skirt extending from the base may comprise a flexible material and may have anchors associated with it. In at least one embodiment, the base is adapted to be implanted in a patient's skin and at least a portion of the base, positioned adjacent the patient's skin, can have a textured surface to promote skin ingrowth. In certain embodiments, this feature can help to reduce trauma and to provide lateral stabilization of the percutaneous connector.

**[0013]** The percutaneous connector may have a base contact connectable to a cap contact. In some embodiments, the base magnets and cap magnets are exposed at the base surface and cap surface. The percutaneous connector may include a channel extending through the base about which the base magnets are positioned and may also include a bore extending through the cap about which the cap magnets are positioned.

**[0014]** In another embodiment, the base contact and a cap contact can be configured to form an electrical connection providing two-way communication between an internal device and external controller.

**[0015]** The base contact and cap contact can each include at least one of a pin and socket. The internal device can include a ventricular assist device, or other subcutaneously implanted device that may need power, telemetry, command, or control.

**[0016]** The magnetic poles of the base magnets and cap magnets may extend perpendicularly to the base surface and cap surface; at least one of the base magnets can have a polarity adjacent the base surface opposite to the polarity of the other base magnets; and at least one of the cap magnets can have a polarity adjacent the cap surface opposite to the polarity of other cap magnets. One aspect of the disclosure describes that cap and base self-assembling when placed in close proximity to each other.

**[0017]** Another aspect of the disclosure includes a method of disconnecting a percutaneous connector establishing an electrical connection between an internal device and an external controller; the percutaneous connector including a cap and a base, the cap and base each having a plurality of magnets to attract the cap to the base and orient the cap on the base to establish an electrical connection; the method including rotating the cap relative to the base such that a cam positioned on one of the cap or base engages an element on the other of the cap or base, wherein the engaged cam and

element cause relative separation between the cap and base; and pulling the cap away from the base.

#### BRIEF DESCRIPTION OF THE DRAWINGS

**[0018]** A more complete appreciation of the subject matter of the present invention and the various advantages thereof can be realized by reference to the following detailed description, in which reference is made to the accompanying drawings:

**[0019]** FIG. 1 illustrates one embodiment of the percutaneous connector of the present invention.

**[0020]** FIG. 2 illustrates a perspective view of the base of FIG. 1.

**[0021]** FIG. 3 illustrates a top view of the base of FIG. 2.

**[0022]** FIG. 4 illustrates a perspective view of a first portion of the cap of FIG. 1.

**[0023]** FIG. 5 illustrates a bottom view of the first portion of the cap of FIG. 4.

**[0024]** FIG. 6 illustrates a bottom view of the second portion of the cap of FIG. 1.

**[0025]** FIG. 7 illustrates a top view of the second portion of the cap of FIG. 1.

**[0026]** FIG. 8 illustrates a schematic drawing of a communication between an internal device and external controller.

**[0027]** FIGS. 9A and 9B illustrate a sectional view of one embodiment of a pin of the present invention.

**[0028]** FIG. 10 illustrates one embodiment of an inert cap of the present invention.

#### DETAILED DESCRIPTION

**[0029]** In a first embodiment, illustrated in FIGS. 1-7, a percutaneous connector 1 comprises a cap 2 and a base 3. As will be discussed more fully below, the percutaneous connector 1 is designed to provide a detachable electrical connection between an internally implanted device and an external controller or device. One type of internal device

contemplated for use with the percutaneous connector is disclosed in U.S. Patent No. 6,688,861, the entirety of which is incorporated by reference as if fully set forth herein. The external controller used with the percutaneous connector may be similar to that disclosed in pending U.S. Application No. 12/602,914 filed May 24, 2010, the entirety of which is incorporated by reference herein as if fully set forth herein. Other internal devices (e.g. a transcutaneous energy transfer (TET) system, pacemaker, insulin pump, dialysis device, automatic implantable cardioverter defibrillator) and external controllers, and associated power sources, may also be used with the percutaneous connector of the present invention.

**[0030]** In the embodiment shown in Fig. 1, the cap 2 and base 3 are depicted having similar cross sectional diameters. In other embodiments, one of the cap and base could have a larger diameter than the other to form inter-fitting cylinders.

**[0031]** FIG. 2 details one embodiment of the base 3. The base 3 has an internal portion 25 and an external portion 26. The internal portion 25 is positioned in or under a patient's skin when the base 3 is implanted. The external portion 26 protrudes through the skin of the patient to provide a base surface 30 to connect to the cap, as will be discussed more fully below. The base 3 is preferably formed of titanium or other material suitable to be implanted into the body of a patient, though other biocompatible materials are also envisioned.

**[0032]** In the embodiment shown, the base 3 has an internal portion 25 adapted for mounting within the patient's body and an external portion 26 adapted for mounting at or near the skin so that a base surface 30 is exposed to the outside of the patient's body. A lateral stabilizer or skirt 21 extends radially from the base 3 and as illustrated, is positioned between the internal portion 25 and the external portion 26. The skirt 21 provides a surface for tissue ingrowth to

prevent dislodgement of the base 3. It is believed that the skirt may also provide consistent orientation of the internal portion should the patient's weight or body shape change. Although the skirt is shown as a circular disk, other embodiments are also envisioned such as multiple extending strips, a square sheet, oval shaped, differing diameter or size and differing thickness, etc. The skirt 21 could also have anchors (e.g. barbs or other attaching features) associated with it to increase the anti-rotation power of the skirt. The skirt shown is a flexible mesh but could also be a perforated material such as titanium wool, titanium mesh or the like and could also be a polymer or other biocompatible material. The perimeter of the skirt is featured to minimize trauma or irritation to the muscle, fat, and/or skin layers as a result of repetitive movement.

**[0033]** The perforated or porous material of the skirt allows the ingrowth of tissue to intertwine with the skirt which may create an anchor with a footprint matching the geometric shape of the skirt. Therefore, a larger skirt will typically result in a greater anchoring force. A larger skirt may also result in spreading mechanical forces applied to the base over a larger region of the patient's skin. This decreases concentration of pressure on the skin in the immediate proximity of the base 3, and instead spread the pressure over the area of the skirt. The diffusion of pressure across the area of the skirt may reduce patient discomfort in situations where the cap and base experience contact with external elements, such as during removal of the cap. The skirt 21 can also have reinforcing members 33 to secure the skirt 21 to the base 3. The skirt could also include a silicon or Teflon ring extending around its perimeter, a Dacron or other woven fabric material design, or a rounder outer edge to minimize trauma around the perimeter of the skirt.

**[0034]** It is believed that a textured surface 27 around the base 3 further promotes skin ingrowth in the area just

below where the base protrudes from the skin. The textured surface 27 can include the same material as that used for the skirt 21. Alternatively, the textured surface 27 could also incorporate other methods for providing a skin ingrowth area, for example, sintered titanium or other type of porous surface or patterned texturing surface application. Skin ingrowth around the exit site can provide a better seal to reduce the likelihood of infections resulting from internal exposure to external contaminants.

**[0035]** The skirt 21 can be positioned anywhere on the base 3 as desired. For example, if a more "low-profile" base 3 is desired, the skirt could instead be positioned higher on the base, such as adjacent to the base surface 30, so that the skirt will be disposed closer to the skin surface when the base is positioned in the patient's body. In this arrangement, most of the base would then be positioned under the patient's skin. In another alternative, more than one skirt can be included on the base to, for example, contact with multiple tissue layers in the epidermis. Such an alternative arrangement could also result in a more "low-profile" base and also improve the attachment of the base of the patient's skin.

**[0036]** Continuing with this embodiment, the base surface 30 has a set of base contacts 28. In this embodiment, the base contacts are in the form of metallic elements 28a, each defining a small recess. The metallic elements are disposed in a block 28b of dielectric material which insulates the contacts from one another. The base contacts 28 can be any type of connection that provides a detachable electrical connection. Merely by way of example, each metallic element may be a receptacle manufactured by Mill-Max Manufacturing Corp. of Oyster Bay, NY for use with a mating element referred to as a "pogo pin" from the same manufacturer. As shown, the base 3 has magnets 24, 29 exposed at the base surface 30. The magnets 24, 29 each have their respective magnetic poles extending generally perpendicularly to the

base surface 30, and thus also extending perpendicular to the patient's skin. The magnets 24, 29 can have opposite polarity exposed at the base surface 30. For example, magnet 24 could have its north pole exposed at the base surface 30 while magnet 29 has its south pole exposed, or vice versa. Magnets with opposite polarity exposed will assist a user in properly aligning the cap on the base during use. Although the base surface 30 is shown with two magnets, any number of magnets could be used. When more than two magnets are implemented, it is preferable that only one magnet has exposed polarity opposite that of the others for alignment purposes, although more than one could be arranged in this manner. In other embodiments, the base magnets can all have the same pole exposed. The magnets need not be exposed at the surface and instead could be positioned adjacent the surface.

**[0037]** The base surface 30 also has a release mechanism, depicted in this embodiment as multiple recesses 23. The recesses shown have a hemispherical shape. Thus, the outer portions of the recesses, close to the base surface 30 extend at an oblique angle to the base surface. The recesses could also be elliptical, angled, trapezoidal, etc. The recesses 23 can be implemented in cooperation with the cam members 45 (FIG. 4) of the cap 2 to properly align the cap 2 and base 3. The recess and cam members could be formed on either of the cap and base, or any combination thereof.

**[0038]** FIG. 3 illustrates a bottom view of the base 3 showing the inner end 34, i.e., the end internal portion 25 which faces into the patient's body, and away from the skin surface, when the base 3 is implanted in the patient. Inner end 34 faces opposite from base surface 30 depicted in Fig. 2, with some elements removed for clarity of illustration. A channel 31 extends through the base 3 from the internal portion 25 toward the external portion 26 (FIG. 2). In the embodiment shown, a wall 37 (Fig. 3) blocks one end of the channel 31. The insulating block 28b and metallic contacts

28a are also shown. A conduit 22 extends from a side of the base 3 between wall 37 and inner end 34. Conduit 22 communicates with channel 31. The channel 31 and conduit 22 provide a passageway for an electrical conductor such as a multi-conductor cable 80 (Fig. 8) to connect with the contacts 28a. The electrical conductor or cable (not shown in Fig. 2) may pass out of the connector through the conduit, and may extend under the skin of a patient and within the patient's body to the internal device. The inner end 34, positioned on the opposite end of the channel from the base surface 30, has a ledge 32 to receive a plug (not shown) to effectively seal the channel 31. The plug can be attached to the base 3 prior to implanting to ensure no foreign materials enter the base. A detachable plug allows the installer to visually confirm that a proper connection has been established between the electrical connector and the base contact 28 prior to implanting. Alternatively, the base 3 could be manufactured with a permanent plug thereon. The plug and base are hermetically sealed to each other once they are coupled to together. Alternatively or additionally, the channel 31 may be filled with a dielectric potting material after connecting the conductor to the contacts 28b.

**[0039]** FIGS. 4-7 illustrate one embodiment of the cap 2 of the percutaneous connector of FIG. 1. The cap 2 in the embodiment shown has a first portion 41 (also shown in FIG. 5) and a second portion 50 (also shown in FIGS. 6-7). The first portion 41 has magnets 47, 48 exposed at a cap surface 42. The magnets 47, 48 are arranged in a pattern similar to that of the base magnets 24, 29 such that the base and cap magnets align when the cap surface and base surface are connected. Similarly to the base magnets, the cap magnets 47, 48 can have their magnetic pole axes extending perpendicularly to the cap surface 42. The cap magnets 47, 48 can have opposite magnetic poles exposed at the cap surface 42, similar to the base magnets 24, 29, as discussed above. In the embodiments where one of the magnetic poles is

opposite, the result of such opposite polarity is that the cap 2 can only be coupled to the base 3 in a particular orientation. The magnets can also provide the additional benefit that as the cap and base are brought into proximity with each other, the magnets automatically align and couple the cap surface to the base surface.

**[0040]** In other embodiments, the cap and base can have an unequal number of magnets to allow the cap to be coupled to the base in more than one orientation. The base and cap could also have different sized magnets. The cap is preferably formed of a polymer such as HDPE or similar material, although other materials are also possible.

**[0041]** In other embodiments, the size of the cap can be smaller or larger relative to the base. A larger cap relative to the base can house larger magnets and therefore provide a stronger coupling force between the cap and base. A smaller cap relative to the base could provide a smaller coupling force.

**[0042]** As shown, the cap 2 has cam members 45 protruding from the cap surface. The cam members 45 are arranged to match the pattern of the recesses 23 on the base 3. The cam members 45 extend into the recess 23 when the cap 2 and base 3 are connected. In other embodiments, both cam members 45 and recesses 23 can be formed on the cap surface 42 and the base surface 30. Cam members 45 are generally hemispherical. Near the juncture of the cam members with the cap surface, the surface of each cam member is disposed at an oblique angle to the cap surface.

**[0043]** A set of cap contacts 46 is disposed in the cap. Cap contacts 46 project from cap surface 42. The cap contacts 46 mate with the base contact 28 to provide an electrical connection between an internal device and external controller. In this embodiment, each cap contact 46 is a spring force adjusted pin, commonly referred to as a "pogo pin". As shown in Figs. 9A and 9B, each pogo pin includes a fixed body 91 and a mobile element 93 capable of limited

translational movement along the pin axis. FIG. 9A shows the pogo pin with the mobile element 93 in the extended state. FIG. 9B shows the pogo pin in a compressed state. A spring 94 biases the mobile element to the extended state depicted in FIG. 9A. When the mobile element is in the extended state, it projects out of the cap surface 42. Each mobile element 93 can be moved toward a retracted state shown in Fig. 9B) and thus moved toward the cap surface. The use of contacts with mobile elements reduces the precision necessary in manufacturing the cam and recesses of the base and cap while still providing a secure electrical connection between the pin and receiver.

**[0044]** Another advantage of using contacts with mobile elements such as the pogo pins discussed above is that they maintain contact between the cap contacts and the base contacts as the cap is moved relative to the base. As the movement occurs, the mobile cap contacts wipe the surfaces of the base contacts. This wipe removes any oxide or contaminant from the electrical contact surfaces and counteracts electrical resistance build-up. Of course, other contact types could also be used to achieve this feature.

**[0045]** The cap 2 has an arm 44 extending from a head 49. The arm 44 preferably has an opening 43 extending through it to house an electrical connector (e.g. a wire) which connects the cap contact 46 to the external controller and/or power source.

**[0046]** FIG. 5 shows a bottom view of the first portion 41 of the cap 2 of FIG. 1. The cap contact 46 extends through the first portion 41 of the cap 2. In the embodiment shown, the bottom of the first portion 41 is coupled to the top of the second portion 50 when the cap 2 is assembled.

**[0047]** FIGS. 6 and 7 illustrate bottom and top views, respectively, of one embodiment of the second portion 50 of the cap 2 of FIG. 1. The second portion can have a bore 61 in the head 49 to receive a printed circuit board or other type of connection between an electrical conductor such as a

multiconductor cable (not shown) and the cap contacts 46. Alternatively, the electrical conductor could also connect directly to the cap contacts 46. The bore 61 is in communication with the opening 43 to house the electrical connector. The second portion 50 has a ledge 62 extending around its perimeter to secure the first portion 41 thereto. As shown in FIG. 7, the top side 71 of the arm 44 extending from the head 49 is adapted to house an electrical conductor having a circular cross-section. However, the arm 44 can be adapted to house any shape electrical connector including square or flat connectors.

**[0048]** An electrical connection between an internal device and external controller is established when the cap contact 46 and base contact 28 are connected. The electrical connection provides one-way or two-way communication between the internal device and external controller as shown schematically in Fig. 8. For example, the external controller can provide power as well as operating signals to the internal device, while in two-way communication, the internal device can also provide operational feedback to the controller.

**[0049]** A user can engage the cap 2 and base 3 simply by bringing the cap and base close to one another, with the cap surface 42 facing generally toward the base surface 30. The magnetic poles of the cap and base cooperatively pull the cap and base toward one another, so that the cap surface is disposed adjacent the base surface and confronts the base surface. The magnetic poles also act to rotate the cap relative to the base about an axis perpendicular to the confronting cap and base surfaces until the cap is in the correct rotational position. In this correct position, each correct cap contact 46 is aligned with the correct base contact 28a. Also, in this correct position, the cam members 45 on the cap are aligned with the recesses 23 in the base surfaces. Notably, if the user attempts to assemble the cap and base with the cap 180 degrees out of the correct

position, the magnetic poles of the cap and base will repel, rather than attract one another, and thus the cap cannot be assembled to the base.

**[0050]** The user may separate the cap 2 from the base 3 as necessary. In one embodiment, the present invention includes a method of separating the cap from the base including rotating the cap 2 relative to the base 3. As the cap 2 rotates, the oblique surfaces of the cam members 45 and recesses 23 will interact with one another to lift the cap away from the base, thereby causing relative separation between the cap 2 and base 3. The cap magnets 47, 48 and base magnets 24, 29 become misaligned as the cap rotates, and further, the distance between the cap and base magnets increases, thereby decreasing the magnetic attraction between the cap 2 and base 3. After the cam member 45 causes this relative separation between the two sets of magnets, the user can pull the cap away from the base.

**[0051]** The percutaneous connector may also include an inert cap 100 as shown in FIG. 10. The inert cap 100 has a head 102 similar to the head 49 of the cap 2. However, the inert cap 100 does not provide an electrical connection. Instead, the inert cap can be used to provide a seal when the inert cap is coupled to the base. The inert cap 100 includes wings 104 which a user can contact to detach the inert cap from the base. The inert cap can include any of the attachment and detachment features discussed above which couple the cap 2 to the base 3. For example, the inert cap preferably has the same attachment feature as the cap 2 to allow cap 2 and inert cap 100 to be used interchangeably with the base 3. The inert cap may also have holes with screw threads aligned with threaded holes in the base to receive a screw to secure the inert cap to the base. The inert cap 100 can also include a sealing member 102 extending around its face which promotes a waterproof seal between the inert cap and base, for example, when taking a shower.

**[0052]** Further, in embodiments with cap magnets having alternating polarity exposed at the cap surface and corresponding base magnets having opposite polarity, further rotation of the cap relative to the base can cause cap and base magnets with the same polarity to become aligned, thereby causing magnetic repulsion between the cap and base.

**[0053]** The cam and recess configuration may reduce discomfort for a patient in situations where the cap, for example, becomes snagged in a user's clothes or contacts another surface which causes the cap to dislocate from the base. The preferred hemispherical shape of the cam enables separation whether the cap is rotated, pushed, or otherwise moved with respect to the base.

**[0054]** The various embodiments of opposing magnets and release mechanism, such as the cam and recess configuration, may provide for reduced overall discomfort of the patient. This is particularly true in instances where the cap needs to be removed from the base. The release mechanism and/or opposing magnets allow for simplified release of the cap due to the reduced magnetic attraction between the cap and base. Further, the ability of the patient, or other individual, to manipulate the cap to decrease the magnetic attraction may also allow for the use of stronger magnets. As such, the stronger magnets may allow for an increased attraction between the cap and base, and thus fewer instances of accidental separation of the cap from the base.

**[0055]** Although the invention herein has been described with reference to particular embodiments, it is to be understood that these embodiments are merely illustrative of the principles and applications of the present invention. It is therefore to be understood that numerous modifications may be made to the illustrative embodiments and that other arrangements may be devised without departing from the spirit and scope of the present invention as defined by the appended claims.

## CLAIMS

1. A percutaneous connector comprising:
  - a base having a base surface;
  - one or more base magnets within the base defining a plurality of magnetic poles adjacent the base surface;
  - a cap having a cap surface;
  - one or more cap magnets within the cap defining a plurality of magnetic poles adjacent the cap surface, the base magnets and cap magnets attract the cap to the base and align the cap and base with the cap surface and base surface confronting one another; and
  - a release mechanism adapted to at least partially separate the cap from the base when the cap is rotated relative to the base about an axis normal to the cap surface and base surface.
2. The percutaneous connector of claim 1, further comprising a skirt extending from the base.
3. The percutaneous connector of claim 1, wherein the base magnets and the cap magnets each have their respective magnetic polar axes extending perpendicularly to the base surface and cap surface.
4. The percutaneous connector of claim 3, wherein at least one of the one or more base magnets define at least one north pole and at least one south pole adjacent to the base surface, and
  - wherein the one or more cap magnets define at least one north pole adjacent to the cap surface and at least one south pole adjacent to the cap surface.
5. The percutaneous connector of claim 4, wherein the plurality of poles defined by the base magnets and the plurality of poles defined by the cap magnets are equally spaced such that each base magnet pole aligns with a cap magnet pole.
6. The percutaneous connector of claim 4, wherein the base and cap have an unequal number of magnets to allow different orientations of the cap with respect to the base.

7. The percutaneous connector of claim 5, wherein rotation of the cap misaligns the base magnets and cap magnets to reduce the magnetic attraction between the cap and base.

8. The percutaneous connector of claim 7, wherein further rotation of the cap causes magnetic repulsion between the base magnets and the cap magnets.

9. The percutaneous connector of claim 1, wherein the release mechanism comprises at least one cam formed at an oblique angle to the surface of one of the cap and base and at least one mating structure adapted to engage the at least one cam formed on the other of the cap and base.

10. The percutaneous connector of claim 2, wherein the skirt comprises a flexible material.

11. The percutaneous connector of claim 2, further comprising a plurality of anchors associated with the skirt.

12. The percutaneous connector of claim 1, wherein the base is adapted to be implanted at least partially in a patient's skin and at least a portion of the base, positioned adjacent the patient's skin, having a textured surface to promote tissue ingrowth.

13. The percutaneous connector of claim 1, further comprising a base contact configured to be coupled to a cap contact.

14. The percutaneous connector of claim 1, wherein the base magnets and cap magnets are exposed at the base surface and cap surface.

15. The percutaneous connector of claim 1, further comprising a channel extending through the base, wherein the base magnets are positioned around the channel; and

a bore extending through the cap, wherein the cap magnets are positioned around the bore.

16. The percutaneous connector of claim 1 wherein the base contact and cap contact are configured to form an electrical connection providing two-way communication between an internal device and external controller.

17. The percutaneous connector of claim 16, wherein the base contact and cap contact each comprise at least one of a pin and socket.

18. The percutaneous connector of claim 16, wherein the internal device comprises at least one of a ventricular assist device, insulin pump, pacemaker, automatic implantable cardioverter defibrillator, and dialysis device.

19. The percutaneous connector of claim 16, wherein the magnetic poles of the base magnets and cap magnets extend perpendicularly to the base surface and cap surface,

at least one of the base magnets has a polarity adjacent the base surface opposite to the polarity of the other base magnets, and

at least one of the cap magnets has a polarity adjacent the cap surface opposite to the polarity of the other cap magnets.

20. The percutaneous connector of claim 19, wherein the base and cap self-assemble when placed in close proximity to each other.

21. A method of disconnecting a percutaneous connector establishing an electrical connection between an internal device and an external controller, the percutaneous connector including a cap and a base, the cap and base each having a plurality of magnets to attract the cap to the base and orient the cap on the base to establish the electrical connection, the method comprising the steps of:

rotating the cap relative to the base such that a cam positioned on one of the cap or base engages an element positioned on the other of the cap or base, wherein the engaged cam and element cause relative separation between the cap and base; and

pulling the cap away from the base.

22. The percutaneous connector of claim 1, further comprising an inert cap adapted to be coupled to the base.

23. The percutaneous connector of claim 22, wherein the inert cap has one or more inert cap magnets within the inert

cap defining a plurality of magnetic poles adjacent the inert cap surface.

24. The percutaneous connector of claim 23, wherein the inert cap has a sealing member creating a waterproof seal between the inert cap and the base.

25. A percutaneous connector comprising:

a base having a base surface;

one or more base magnets within the base defining a plurality of magnetic poles adjacent the base surface;

a cap having a cap surface; and

one or more cap magnets within the cap defining a plurality of magnetic poles adjacent the cap surface, the base magnets and cap magnets attract the cap to the base and align the cap and base with the cap surface and base surface confronting one another.

1/5

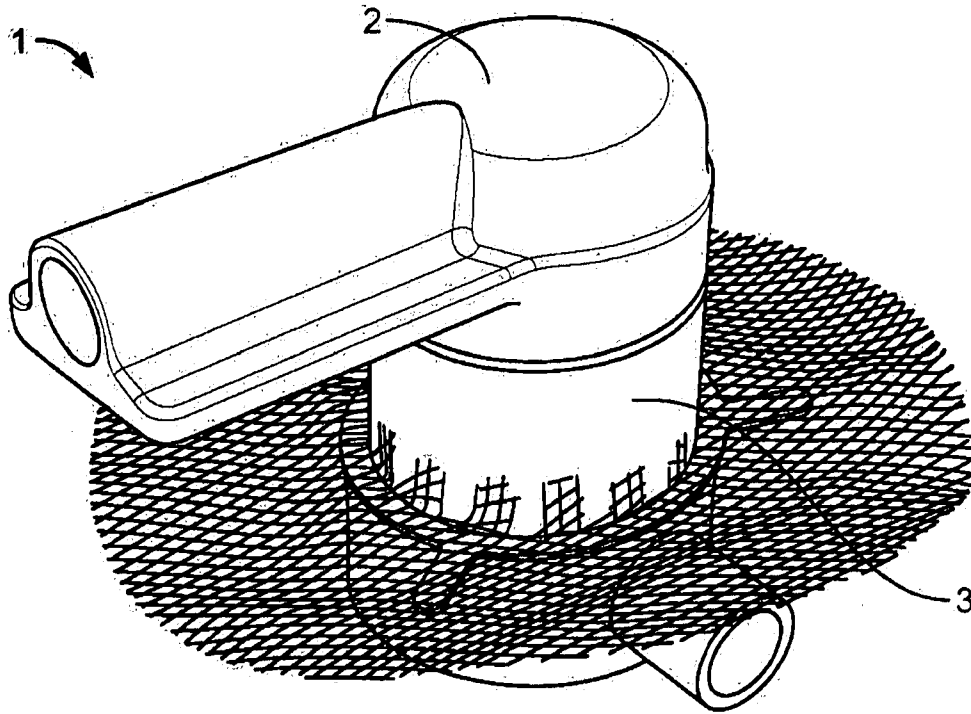

FIG. 1

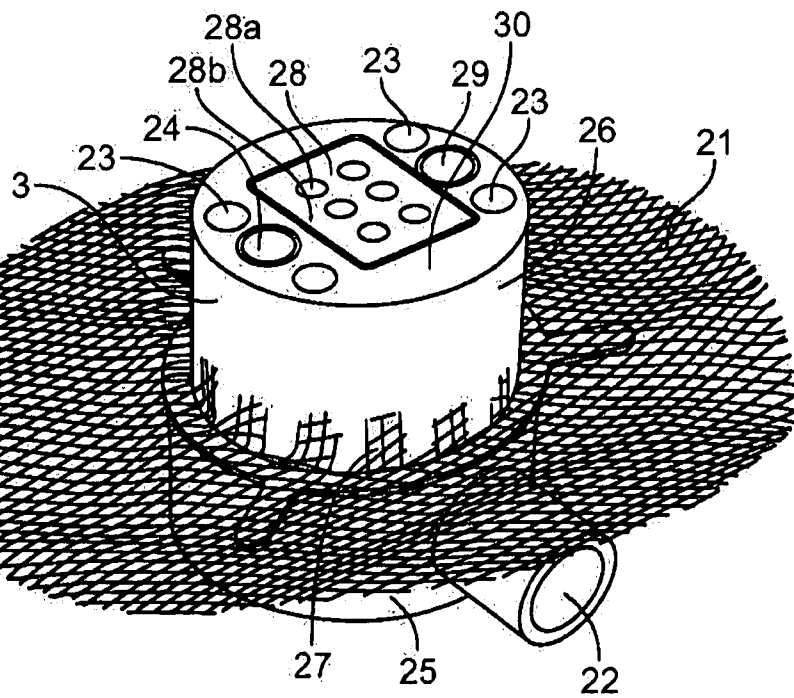

FIG. 2

2/5

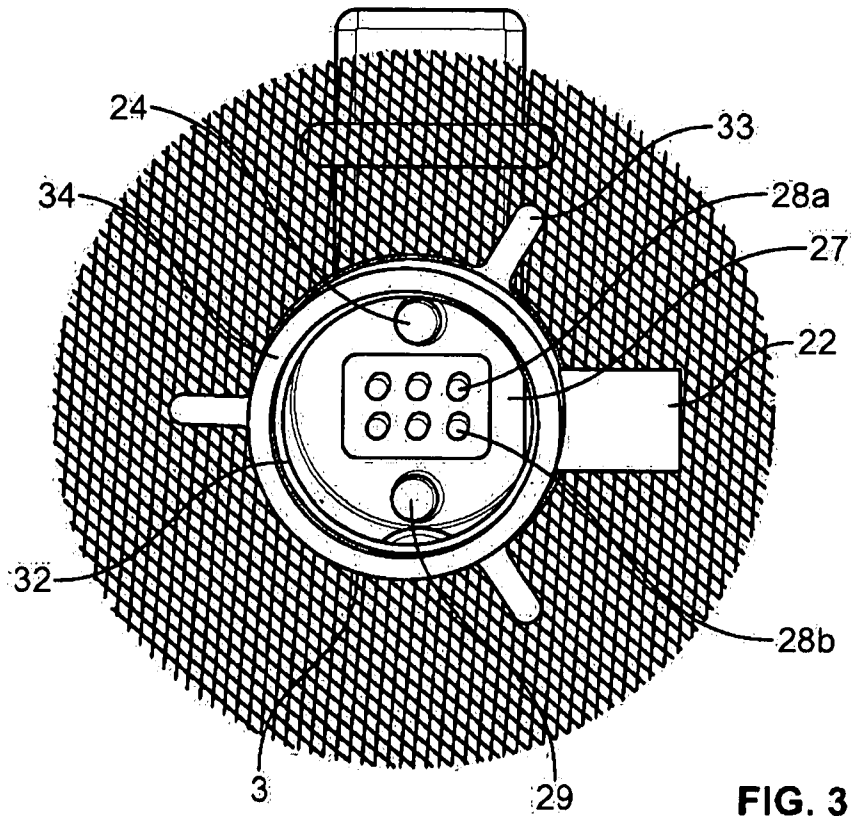

FIG. 3

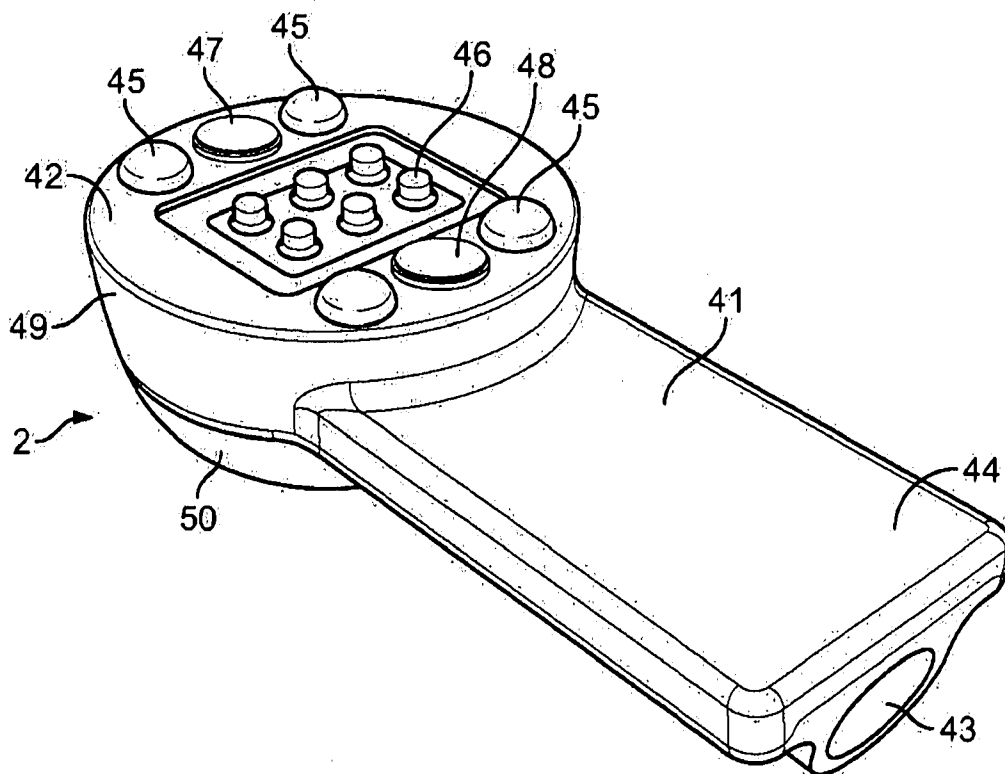

FIG. 4

3/5

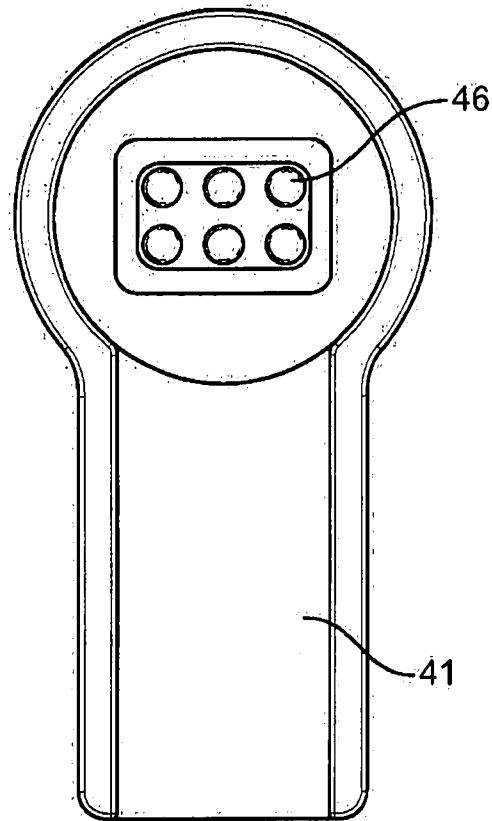

FIG. 5

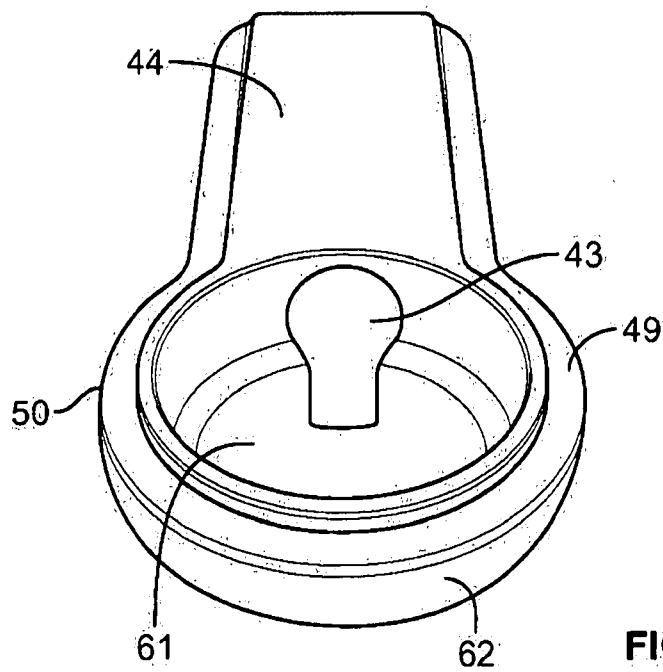

FIG. 6

4/5

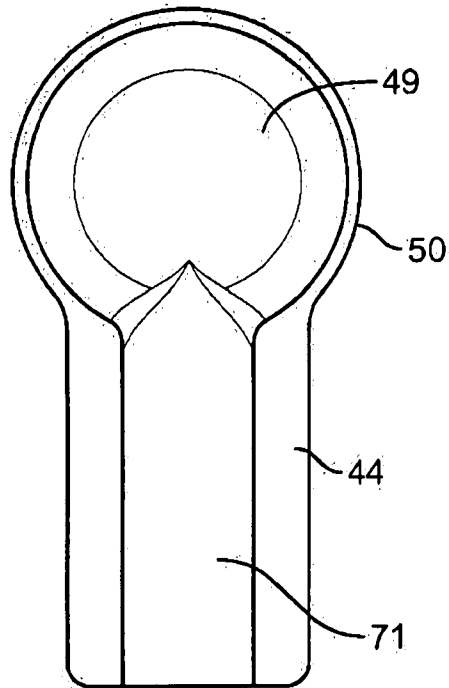

FIG. 7

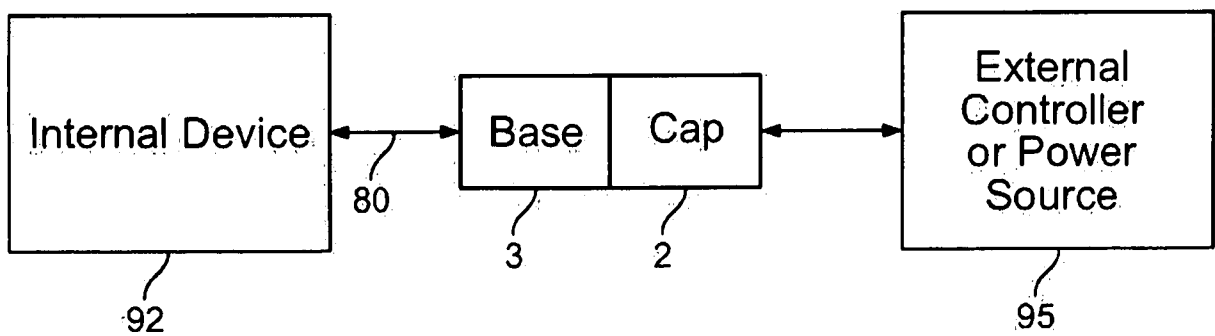

FIG. 8

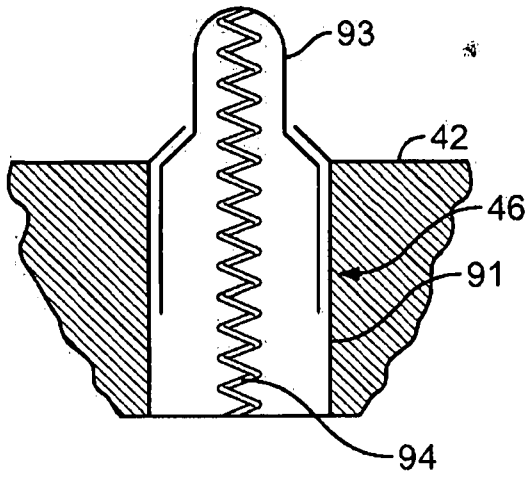

FIG. 9A

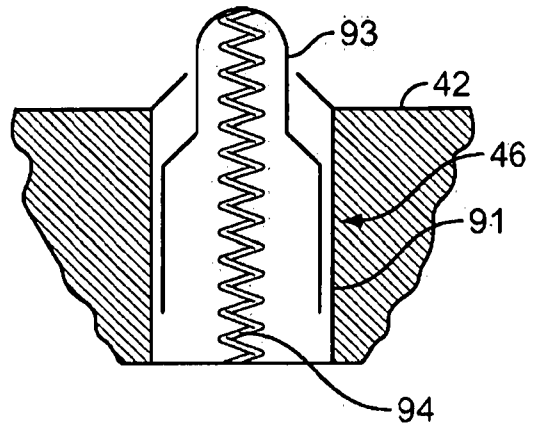

FIG. 9B

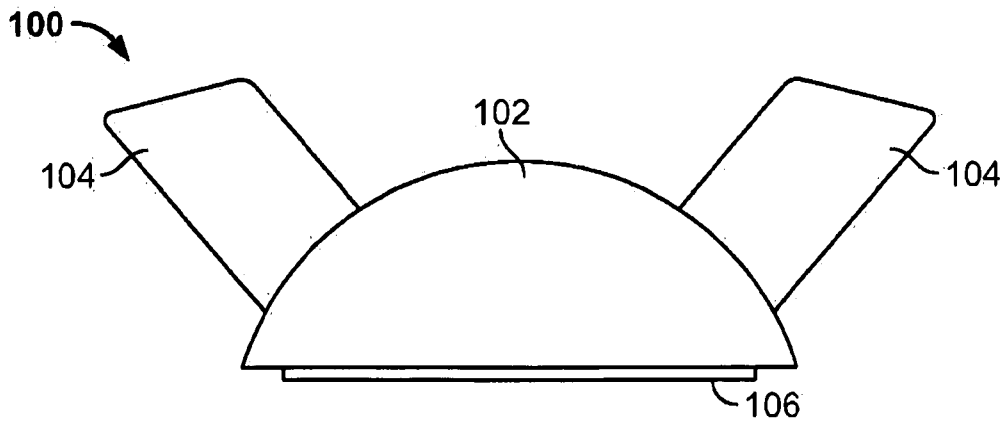

FIG. 10

**INTERNATIONAL SEARCH REPORT**

International application No  
PCT/US2015/035657

**A. CLASSIFICATION OF SUBJECT MATTER**  
 INV. A61M39/02                      A61M1/12  
 ADD. A61B5/00                      H01R13/52                      H01R13/62

According to International Patent Classification (IPC) or to both national classification and IPC

**B. FIELDS SEARCHED**  
 Minimum documentation searched (classification system followed by classification symbols)  
 A61M A61B H01R H01F A61N

Documentation searched other than minimum documentation to the extent that such documents are included in the fields searched

Electronic data base consulted during the international search (name of data base and, where practicable, search terms used)  
 EPO-Internal, WPI Data

**C. DOCUMENTS CONSIDERED TO BE RELEVANT**

Category*	Citation of document, with indication, where appropriate, of the relevant passages	Relevant to claim No.
X	US 4 004 298 A (FREED PAUL S) 25 January 1977 (1977-01-25) in particular col. 6, lines 61-65; columns 2-7; claims 1-7; figures 1-4, 7-10 -----	1-25
Y	US 7 793 987 B1 (BUSCH LANCE [US] ET AL) 14 September 2010 (2010-09-14) column6, lines 45-61; figures 1-7 -----	9
Y	US 2009/293238 A1 (DAVIS MITCHELL G [US]) 3 December 2009 (2009-12-03) paragraph [0082]; figures 1-11 -----	9
A	WO 01/83023 A2 (PHONAK AG [CH]; SCHMID CHRISTOPH HANS [CH]; BAECHLER HERBERT [CH]) 8 November 2001 (2001-11-08) page 6; claims 1-15; figure 1 ----- -/--	1-25

Further documents are listed in the continuation of Box C.                       See patent family annex.

\* Special categories of cited documents :

<p>"A" document defining the general state of the art which is not considered to be of particular relevance</p> <p>"E" earlier application or patent but published on or after the international filing date</p> <p>"L" document which may throw doubts on priority claim(s) or which is cited to establish the publication date of another citation or other special reason (as specified)</p> <p>"O" document referring to an oral disclosure, use, exhibition or other means</p> <p>"P" document published prior to the international filing date but later than the priority date claimed</p>	<p>"T" later document published after the international filing date or priority date and not in conflict with the application but cited to understand the principle or theory underlying the invention</p> <p>"X" document of particular relevance; the claimed invention cannot be considered novel or cannot be considered to involve an inventive step when the document is taken alone</p> <p>"Y" document of particular relevance; the claimed invention cannot be considered to involve an inventive step when the document is combined with one or more other such documents, such combination being obvious to a person skilled in the art</p> <p>"&amp;" document member of the same patent family</p>
---	---

Date of the actual completion of the international search  14 August 2015	Date of mailing of the international search report  24/08/2015
---	--

Name and mailing address of the ISA/ European Patent Office, P.B. 5818 Patentlaan 2 NL - 2280 HV Rijswijk Tel. (+31-70) 340-2040, Fax: (+31-70) 340-3016	Authorized officer  Preller, D
--	--------------------------------------

## INTERNATIONAL SEARCH REPORT

International application No  
PCT/US2015/035657

C(Continuation). DOCUMENTS CONSIDERED TO BE RELEVANT		
Category*	Citation of document, with indication, where appropriate, of the relevant passages	Relevant to claim No.
A	WO 2008/106717 A1 (VENTRASSIST PTY LTD [AU]; AYRE PETER JOSEPH [AU]) 12 September 2008 (2008-09-12) figures 1-2 -----	1-25
A	US 2011/160516 A1 (DAGUE CHARLES [US] ET AL) 30 June 2011 (2011-06-30) figures 1-8 -----	1-25
A	US 2011/298304 A1 (COTTER CHRISTOPHER JAMES [US]) 8 December 2011 (2011-12-08) figures 1-6 -----	1-25
A	US 6 688 861 B2 (WAMPLER RICHARD K [US]) 10 February 2004 (2004-02-10) columns 3, 5 and 8-9; figures 1-8 -----	15

# INTERNATIONAL SEARCH REPORT

Information on patent family members

International application No PCT/US2015/035657
---

Patent document cited in search report	Publication date	Patent family member(s)	Publication date
US 4004298	A	25-01-1977	NONE
-----			
US 7793987	B1	14-09-2010	US 7793987 B1 14-09-2010
			US 2010307497 A1 09-12-2010
-----			
US 2009293238	A1	03-12-2009	AU 2009255508 A1 10-12-2009
			CA 2726075 A1 10-12-2009
			EP 2285704 A1 23-02-2011
			US 2009293238 A1 03-12-2009
			US 2012233819 A1 20-09-2012
			WO 2009148686 A1 10-12-2009
-----			
WO 0183023	A2	08-11-2001	AU 8163701 A 12-11-2001
			US 2003034039 A1 20-02-2003
			WO 0183023 A2 08-11-2001
-----			
WO 2008106717	A1	12-09-2008	NONE
-----			
US 2011160516	A1	30-06-2011	US 2011160516 A1 30-06-2011
			US 2014073838 A1 13-03-2014
-----			
US 2011298304	A1	08-12-2011	AU 2011265023 A1 10-01-2013
			CA 2801719 A1 15-12-2011
			EP 2575922 A2 10-04-2013
			TW 201230524 A 16-07-2012
			US 2011298304 A1 08-12-2011
			US 2013178932 A1 11-07-2013
			US 2014309733 A1 16-10-2014
			WO 2011156391 A2 15-12-2011
-----			
US 6688861	B2	10-02-2004	AT 288770 T 15-02-2005
			AU 7993698 A 25-02-1999
			CA 2240555 A1 13-02-1999
			DE 69828926 D1 17-03-2005
			DE 69828926 T2 06-04-2006
			EP 0901797 A2 17-03-1999
			IL 124876 A 04-01-2004
			JP 4248626 B2 02-04-2009
			JP H11123239 A 11-05-1999
			US 5840070 A 24-11-1998
			US 6080133 A 27-06-2000
			US 6234998 B1 22-05-2001
			US 6368083 B1 09-04-2002
			US 2002102169 A1 01-08-2002
			US 2004234397 A1 25-11-2004
-----			

专利名称(译)	带磁帽的经皮连接器及相关使用方法		
公开(公告)号	<a href="#">EP3154624A1</a>	公开(公告)日	2017-04-19
申请号	EP2015730665	申请日	2015-06-12
[标]申请(专利权)人(译)	哈特威尔公司		
申请(专利权)人(译)	心件, INC.		
当前申请(专利权)人(译)	心件, INC.		
[标]发明人	ANDRUS LANCE LYNN CASTILLO ANDRE		
发明人	ANDRUS, LANCE LYNN CASTILLO, ANDRE		
IPC分类号	A61M39/02 A61M1/12 A61B5/00 H01R13/52 H01R13/62		
CPC分类号	H01R13/6205 A61M1/1008 A61M1/101 A61M1/122 A61M1/127 A61M39/0247 A61M2039/0267 A61M2039/0288 A61M2205/3507 A61M2205/3515 H01R13/2421 H01R13/5224		
优先权	62/097304 2014-12-29 US 62/011290 2014-06-12 US		
外部链接	<a href="#">Espacenet</a>		

#### 摘要(译)

在一个实施例中, 本发明包括经皮皮肤连接器1, 其包括基部3和帽2. 基部3具有延伸穿过其的通道31, 并且多个基部磁体24,29定位在通道31周围并且在允许组织向内生长的裙部21从基部3延伸, 以进一步将基部3固定到患者身上. 连接器1还包括盖子2, 盖子2具有穿过其延伸的孔61, 多个盖子磁铁47,48围绕孔61定位并暴露在盖子表面42处. 基座磁铁24,29和盖子磁铁47,48吸引连接器1还包括释放机构, 当盖子2相对于基座3旋转并且与盖子2不对齐时, 该释放机构适于将盖子2与基座3至少部分地分开. 基地3.