



- (51) International Patent Classification:  
*A61B 5/145* (2006.01) *A61B 5/00* (2006.01)
- (21) International Application Number:  
PCT/IB2013/055633
- (22) International Filing Date:  
9 July 2013 (09.07.2013)
- (25) Filing Language: English
- (26) Publication Language: English
- (30) Priority Data:  
13/549,481 15 July 2012 (15.07.2012) US
- (71) Applicant: **CNOGA MEDICAL LTD.** [IL/IL]; North Industrial Park, H-ilan and H- Horev Corner, Or- Akiva (IL).
- (72) Inventor: **SEGMAN, Yosef**; Ha'aliya 1, 3095035 Zichron Yaakov (IL).
- (74) Agent: **DR. MARK FRIEDMAN LTD.**; Moshe Aviv Tower, 54th floor, 7 Jabotinski St., 52520 Ramat-Gan (IL).
- (81) Designated States (unless otherwise indicated, for every kind of national protection available): AE, AG, AL, AM, AO, AT, AU, AZ, BA, BB, BG, BH, BN, BR, BW, BY, BZ, CA, CH, CL, CN, CO, CR, CU, CZ, DE, DK, DM,

DO, DZ, EC, EE, EG, ES, FI, GB, GD, GE, GH, GM, GT, HN, HR, HU, ID, IL, IN, IS, JP, KE, KG, KN, KP, KR, KZ, LA, LC, LK, LR, LS, LT, LU, LY, MA, MD, ME, MG, MK, MN, MW, MX, MY, MZ, NA, NG, NI, NO, NZ, OM, PA, PE, PG, PH, PL, PT, QA, RO, RS, RU, RW, SC, SD, SE, SG, SK, SL, SM, ST, SV, SY, TH, TJ, TM, TN, TR, TT, TZ, UA, UG, US, UZ, VC, VN, ZA, ZM, ZW.

(84) Designated States (unless otherwise indicated, for every kind of regional protection available): ARIPO (BW, GH, GM, KE, LR, LS, MW, MZ, NA, RW, SD, SL, SZ, TZ, UG, ZM, ZW), Eurasian (AM, AZ, BY, KG, KZ, RU, TJ, TM), European (AL, AT, BE, BG, CH, CY, CZ, DE, DK, EE, ES, FI, FR, GB, GR, HR, HU, IE, IS, IT, LT, LU, LV, MC, MK, MT, NL, NO, PL, PT, RO, RS, SE, SI, SK, SM, TR), OAPI (BF, BJ, CF, CG, CI, CM, GA, GN, GQ, GW, KM, ML, MR, NE, SN, TD, TG).

**Published:**

- with international search report (Art. 21(3))
- before the expiration of the time limit for amending the claims and to be republished in the event of receipt of amendments (Rule 48.2(h))

(54) Title: APPARATUS FOR MEASURING BLOOD CHARACTERISTICS FOR DEPLOYMENT ON A HOST DEVICE HAVING A DIGITAL SENSOR

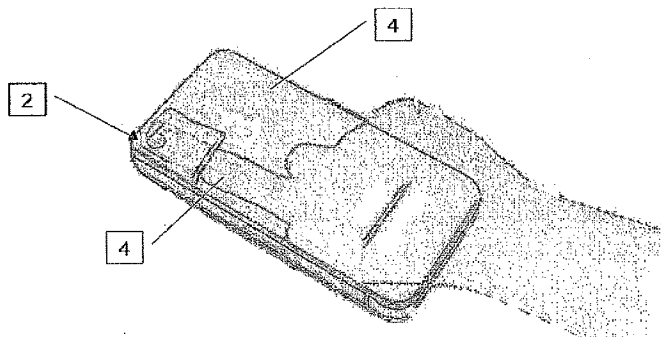

FIG. 1

(57) Abstract: An apparatus for working in conjunction with a digital sensor, CPU and display of a host device in order to measure blood characteristics that includes a housing configured for association with the host device so as to define between them a chamber into which at least a portion of an appendage of a living being is placed such that a tip of the appendage is deployed adjacent to the digital sensor so as to cover the digital sensor. The chamber substantially encloses the digital sensor. Light from a light source is directed toward the appendage tip, wherein at least some light from the light source is reflected by tissue of the appendage, is received by the sensor and data thereby generated is processed by the CPU to determine the blood characteristics.



Apparatus for Measuring Blood Characteristics for Deployment  
on a Host Device having a Digital Sensor

5 FIELD AND BACKGROUND OF THE INVENTION

The present invention relates to devices for measuring blood characteristics and, in particular, it concerns an apparatus for measuring, or determining, blood characteristics for deployment on a host device having a digital sensor, Central Processing Unit and display.

10 It is known to provide devices for measuring blood characteristics by passing light through a portion of a living body, such as a human finger tip. Such a device is described in US Patent Application No. 12/260,251, Finger Deployed Device for Measuring Blood and Physiological Characteristics, the disclosure of which is incorporated herein in its entirety by this reference.

15 Such devices, however, are relatively expensive because they are all inclusive and therefore include a housing, light source, a digital sensor, a Central Processing Unit (CPU) and display.

20 There are numerous consumer devices in use today that include a digital sensor, a CPU and display. Such devices include, but are not limited to, cellular telephone, digital cameras and computers having either a built-in camera or the ability to have a digital camera attached such as by a USB port. Any of these devices therefore, can act as host a device for as apparatus that utilizes the existing digital sensor, CPU and display.

25 There is therefore a need for an apparatus for measuring blood characteristics for deployment on a host device having a digital sensor, Central Processing Unit and display.

## SUMMARY OF THE INVENTION

The present invention is an apparatus for measuring blood characteristics for deployment on a host device having a digital sensor, Central Processing Unit and display.

5           According to the teachings of the present invention there is provided, an apparatus for working in conjunction with a digital sensor, CPU and display of a host device in order to measure blood characteristics, the apparatus comprising, a housing configured for association with the host device so as to define between them a chamber, which substantially encloses the digital sensor,  
10 into which at least a portion of an appendage of a living being is placed such that a tip of said appendage is deployed adjacent to the digital sensor so as to cover the digital sensor and light from a light source is directed toward said appendage tip, wherein at least some light from said light source is reflected by tissue of said appendage, is received by the sensor and data thereby generated  
15 is processed by the CUP to determine the blood characteristics.

          According to the teachings of the present invention, said light source is included in said housing.

          According to the teachings of the present invention, said housing includes two side walls, an end wall and a cover of said chamber and the host  
20 device includes a bottom of said chamber.

          According to the teachings of the present invention, said cover is hingedly attached to said housing.

          According to the teachings of the present invention, said association between said housing and the host device is a detachable connection of the  
25 apparatus to the host device.

          According to the teachings of the present invention, said housing is configured to be interchangeably deployable on at least some of: a cellular telephone, a digital camera, a webcam connected to a computer, a computer having in integral webcam.

According to the teachings of the present invention, said light source is a powered light source configured in said housing.

According to the teachings of the present invention, said light source is powered by at least one of: the host device, an internal battery and a  
5 photovoltaic cell.

There is also provided according to the teaching of the present invention, a method for determining blood characteristics using an apparatus working in conjunction with a digital sensor, CPU and display of a host device, the method comprising: (a) providing the CPU with a program for analyzing  
10 blood characteristics; (b) providing an apparatus having housing configured for association with the host device; (c) providing a light source; (d) associating said housing with said host device so as to define between them a chamber into which at least a portion of an appendage of a living being is placed, said chamber substantially enclosing the digital sensor; (e) placing said at least a  
15 portion of an appendage in said chamber such that a tip of said appendage is deployed adjacent to the digital sensor so as to cover the digital sensor; (f) directing light from said light source toward said tip of said appendage such that at least some light from said light source is reflected by tissue of said appendage; (g) receiving at least some of said reflected light by the digital  
20 sensor; and (h) analyzing data thereby generate is processed by the CUP to determine the blood characteristics.

According to the teachings of the present invention, there is also provided emitting light from said light source, wherein said light source is a powered light source.

25 According to the teachings of the present invention, there is also provided providing power to said light source from at least one of: the host device, an internal battery and a photovoltaic cell.

According to the teachings of the present invention, said housing is configured to provide at least three sides and a cover of said chamber and the  
30 host device provides a bottom of said chamber.

According to the teachings of the present invention, said cover is implemented so as to be hingedly attached to said housing.

According to the teachings of the present invention, said association between said housing and the host device is implemented as a detachable  
5 connected of the apparatus to the host device.

According to the teachings of the present invention, said housing is implemented so as to be interchangeably deployable on at least some of: a cellular telephone, a digital camera, a webcam connected to a computer, a  
10 computer having in integral webcam.

According to the teachings of the present invention, said receiving is implemented such that said digital sensor produces images of spatial-temporal color pixel information acquired by said light being reflected from said light  
15 source into said appendage tip capillary tissue.

According to the teachings of the present invention, said data includes  
15 said spatial-temporal color pixel information so as to determine bio chemical parameters and hemodynamic parameters.

According to the teachings of the present invention, there is also provided displaying a result of said analyzing on a display unit of the host  
20 device.

#### BRIEF DESCRIPTION OF THE DRAWINGS

The invention is herein described, by way of example only, with reference to the accompanying drawings, wherein:

FIG. 1 is an isometric view of the apparatus of the present invention  
25 deployed on a cellular telephone and being used on a human finger;

FIG. 2 is an isometric view of a cellular telephone modified to accept deployment of the apparatus of the present invention;

FIG. 3 is an isometric view of the cellular telephone of FIG. 2 shown here after deployment of the apparatus of the present invention; and

FIG. 4 is an isometric view of the cellular telephone of FIG. 2 shown here the apparatus of the present invention deployed with the hinged lid in an open position.

#### DESCRIPTION OF THE PREFERRED EMBODIMENTS

5           The present invention is an apparatus for measuring blood characteristics for deployment on a host device having a digital sensor and Central Processing Unit

          The principles and operation of an apparatus for measuring blood characteristics according to the present invention may be better understood  
10 with reference to the drawings and the accompanying description.

          By way of introduction, as mentioned above, stand alone devices for measuring blood characteristics by passing light through a portion of a living body, such as a human finger are known. All of these devices include at least a digital sensor and a CPU and usually a display unit as well.

15           There is also a growing sophistication of devices such as, but not limited to, cellular telephones (especially Smartphones as illustrated herein), digital still or video cameras and computers having either a built-in camera or the ability to have a digital camera attached such as by a USB port, and “Apps” to be downloaded and run on these devices. Any of these devices therefore, can  
20 act as host a device for as apparatus that utilizes the existing digital sensor, CPU and display of the host device.

          As used herein, the phrase “host device” refers to substantially any device having a CPU and a digital imaging sensor (hereafter digital sensor) either built-in (integral) or attached/attachable thereto, such as those listed  
25 immediately above.

          The present invention is an apparatus to be used in association with such a host device for measuring or determining blood characteristics. In order to do as, a user simply downloads/installs the necessary software/App. The apparatus

of the present invention is associated with the host device so as to cover the host device's digital sensor. Such association may include detachable connection of the apparatus to the host device, as will be discussed in more detail below. Alternatively, the apparatus housing may be deployed directly on an appendage of the user such as a finger, or toe, and manually held against the host device in a position covering the digital sensor.

The housing of the apparatus is configured with a light source, which may be as simple as a hole in the end wall 16 which allows ambient light to enter the chamber. When configured thusly, the hole may include a lens for directing and/or amplifying the ambient light. It will be appreciated that the ambient light may be naturally occurring such as, but not limited to, sun light. Alternatively, the ambient light may be supplied by a man-made light emitting device such as, but not limited to, incandescent light bulbs, fluorescent light bulbs, LED lights and laser lights.

Preferably, however, the light source is powered and may be a single element or an array of elements such as, but not limited to, LEDs that is preferably mounted on the inside surface of the end wall 16. In this configuration, the light source may be powered by, but not limited to, an electrical connection to the host device or independently by means of an internal battery or a photovoltaic cell (90 in Figure 3), by non-limiting example. It will be understood that such a powered light source requires a control unit. Such a control unit (not shown) may be located in either the apparatus cover, side walls or end wall.

Alternatively, an detached light source may be deployed directly on the host device while being controlled by the apparatus of the present invention.

If the host device includes a flash unit, the host flash may be used as the light source for the present invention.

The digital sensor of the host device produces images of spatial-temporal color pixel information acquired from light that is emitted by the light source and reflected by the finger tip capillary tissue. The spatial-temporal

color pixel information is used to compute bio chemical parameters and hemodynamic parameters by the host device CPU. The results are displayed on the host device's display unit.

Referring now to the drawings, Figure 1 illustrates the apparatus 2  
5 deployed on a Smartphone 4, thereby forming a chamber into which a human finger 6 is inserted.

Figures 2 and 3 illustrated one example of a detachable connection between the host device 4 and the housing 10 of the apparatus 2. In the illustration here, the connection is achieved by matingly sliding the parallel  
10 side walls 12 and 12' on the apparatus housing 10 into the grooves 14 and 14' configured in the host device 4. It will be appreciated that such grooves may be configured in a protective cover for the host device, such protective covers being in common use. It will also be appreciated that the connection of the apparatus of the present invention and the host device may be achieved by  
15 substantially any suitable means known such as, but not limited to, hook and loop arrangements, clamps, clips and elastic bands, all of which may interact directly with the host device, or alternatively with a protective cover deployed on the host device.

As seen in Figure 3, the apparatus housing 10 includes two side walls 12  
20 and 12', an end wall 16 and a cover 18. As illustrated in Figure 4, cover 18 may be hingedly attached to the housing 10 so as to facilitate insertion of the finger into the chamber 30 that is defined by the housing 10 and a portion of the host device 4. Note that the digital camera 40 of the host device 4, which will act as the digital sensor, is located inside of, and substantially enclosed within,  
25 chamber 30 when the apparatus housing 10 is deployed on the host device 4.

Figure 4 comes to illustrate the hinged configuration of housing cover 18 and further shows the end wall 16 and the light source 20.

The present invention also provides a method for using the apparatus. The method includes the steps of:

- (1) Providing the CPU of the host device with a program for analyzing blood characteristics;
- (2) Providing an apparatus having housing configured for association with the host device;
- 5 (3) Providing a light source;
- (4) Associating the housing with the host device so as to define between them a chamber into which at least a portion of an appendage of a living being is placed, the chamber substantially enclosing the digital sensor;
- (5) Placing the at least a portion of an appendage in the chamber  
10 such that a tip of the appendage is deployed adjacent to the digital sensor so as to cover the digital sensor;
- (6) Directing light from the light source toward the tip of the appendage such that at least some light from the light source is reflected by tissue of the appendage;
- 15 (7) Receiving at least some of the reflected light by the digital sensor;
- (8) Analyzing data thereby generated is processed by the CUP to determine the blood characteristics; and
- (9) Displaying the results on the display unit of the host device.

20 It will be appreciated that the above descriptions are intended only to serve as examples and that many other embodiments are possible within the spirit and the scope of the present invention.

## WHAT IS CLAIMED IS:

1. An apparatus for working in conjunction with a digital sensor, CPU and display of a host device in order to measure blood characteristics, the apparatus comprising, a housing configured for association with the host device so as to define between them a chamber, which substantially encloses the digital sensor, into which at least a portion of an appendage of a living being is placed such that a tip of said appendage is deployed adjacent to the digital sensor so as to cover the digital sensor and light from a light source is directed toward said appendage tip, wherein at least some light from said light source is reflected by tissue of said appendage, is received by the sensor and data thereby generated is processed by the CUP to determine the blood characteristics.

2. The apparatus of claim 1, wherein said light source is included in said housing.

3. The apparatus of claim 1, wherein said housing includes two side walls, an end wall and a cover of said chamber and the host device includes a bottom of said chamber.

4. The apparatus of claim 3, wherein said cover is hingedly attached to said housing.

5. The apparatus of claim 1, wherein said association between said housing and the host device is a detachable connection of the apparatus to the host device.

6. The apparatus of claim 1, wherein said housing is configured to be interchangeably deployable on at least some of: a cellular telephone, a digital

camera, a webcam connected to a computer, a computer having in integral webcam.

7. The apparatus of claim 1, wherein said light source is a powered light source configured in said housing.

8. The apparatus of claim 7, wherein said light source is powered by at least one of: the host device, an internal battery and a photovoltaic cell.

9. A method for determining blood characteristics using an apparatus working in conjunction with a digital sensor, CPU and display of a host device, the method comprising:

- (a) providing the CPU with a program for analyzing blood characteristics;
- (b) providing an apparatus having housing configured for association with the host device;
- (c) providing a light source;
- (d) associating said housing with said host device so as to define between them a chamber into which at least a portion of an appendage of a living being is placed, said chamber substantially enclosing the digital sensor;
- (e) placing said at least a portion of an appendage in said chamber such that a tip of said appendage is deployed adjacent to the digital sensor so as to cover the digital sensor;
- (f) directing light from said light source toward said tip of said appendage such that at least some light from said light source is reflected by tissue of said appendage;
- (g) receiving at least some of said reflected light by the digital sensor; and



17. The method of claim 16, wherein said data includes said spatial-temporal color pixel information so as to determine bio chemical parameters and hemodynamic parameters.

18. The method of claim 9, further including displaying a result of said analyzing on a display unit of the host device.

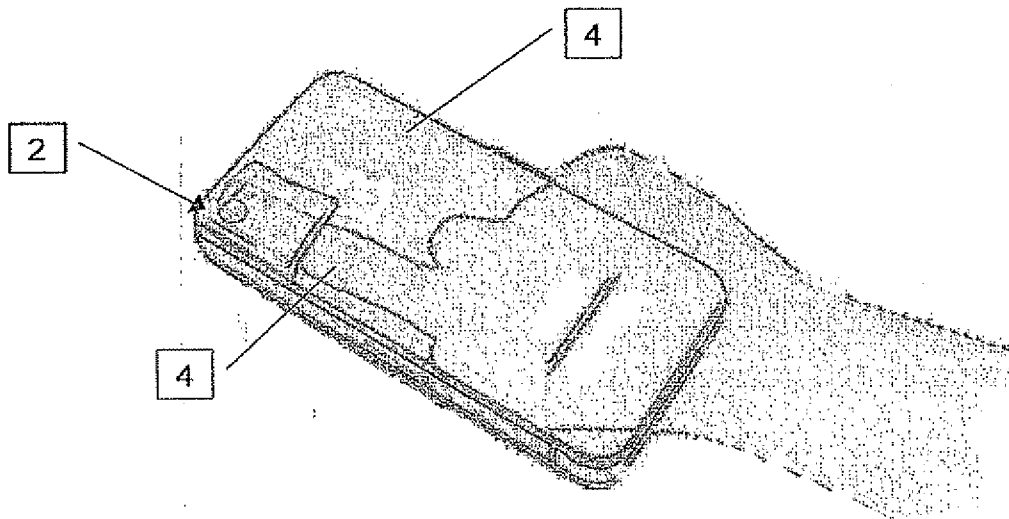

FIG. 1

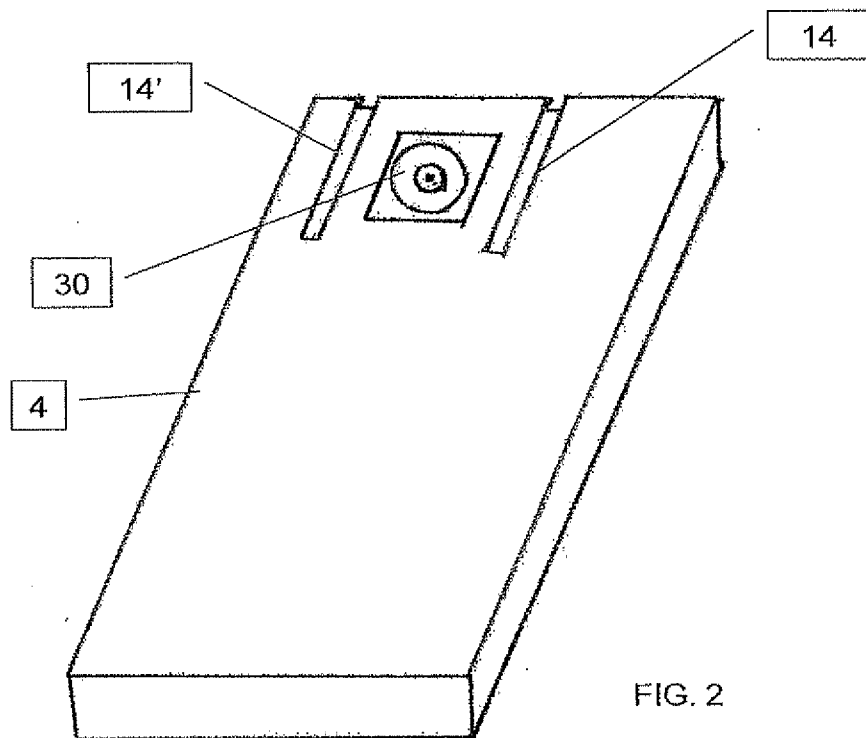

FIG. 2

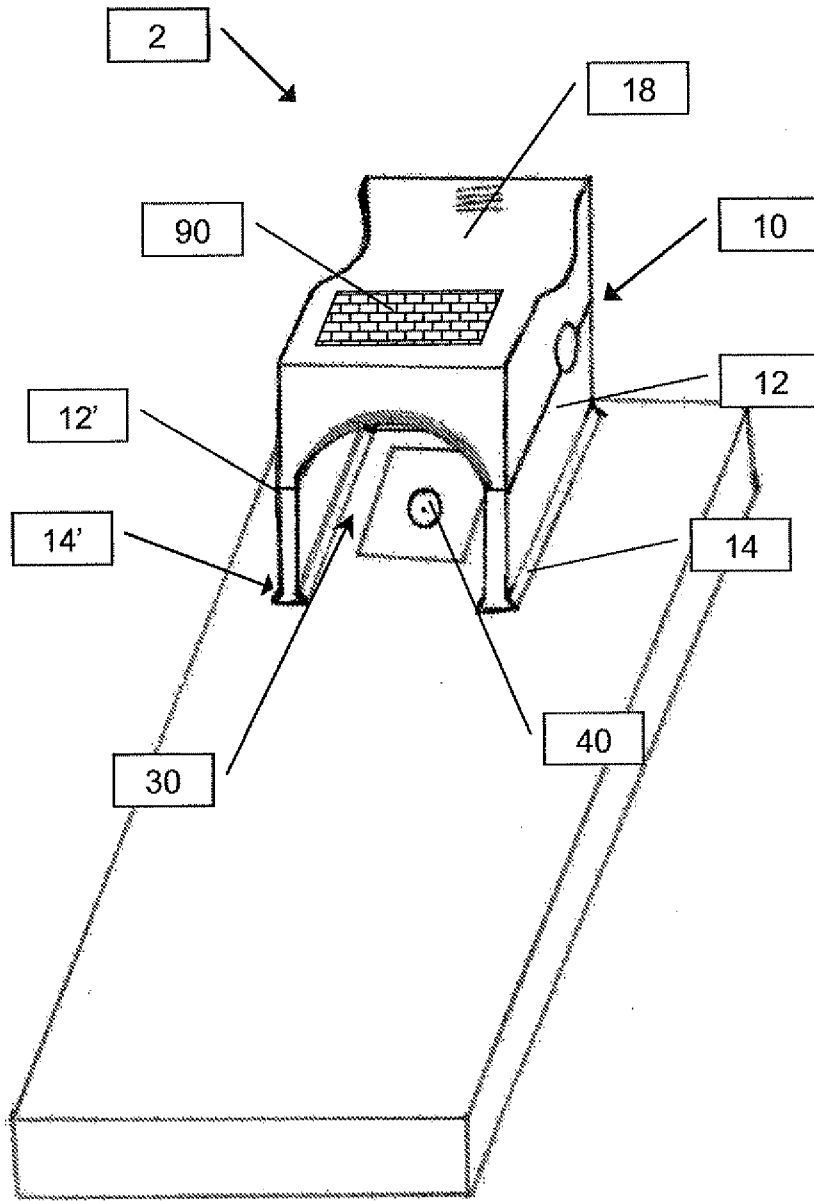

FIG. 3

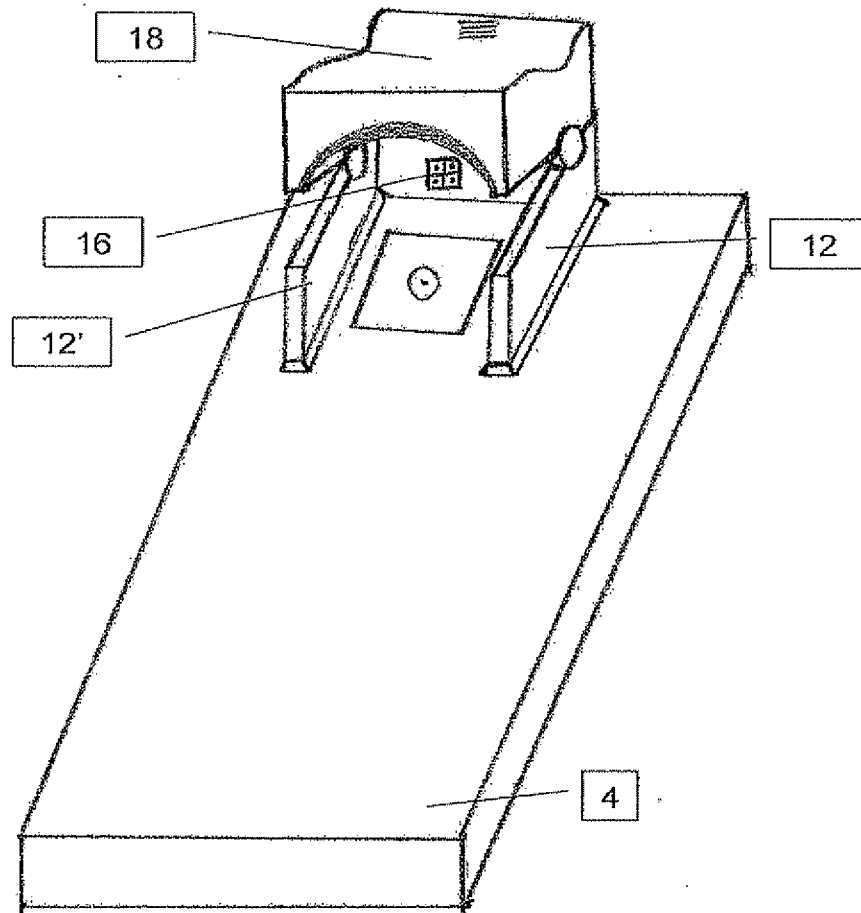

FIG. 4

## INTERNATIONAL SEARCH REPORT

International application No.

PCT/IB2013/055633

A. CLASSIFICATION OF SUBJECT MATTER IPC (2013.01) A61B 5/145, A61B 5/00		
According to International Patent Classification (IPC) or to both national classification and IPC		
B. FIELDS SEARCHED		
Minimum documentation searched (classification system followed by classification symbols) IPC (2013.01) A61B		
Documentation searched other than minimum documentation to the extent that such documents are included in the fields searched		
Electronic data base consulted during the international search (name of data base and, where practicable, search terms used) Databases consulted: THOMSON INNOVATION, Esp@cenet, Google Patents Search terms used: measure, detect, device, apparatus, mobile, cellular, cell, digital, phone, camera, associate, connect, attach, medical, tissue, body, finger, skin, blood		
C. DOCUMENTS CONSIDERED TO BE RELEVANT		
Category*	Citation of document, with indication, where appropriate, of the relevant passages	Relevant to claim No.
Y	WO 2009088930 A2 UNIV. CALIFORNIA et al. 16 Jul 2009 (2009/07/16) para.[0015]-[0019], [0024], [0047], [0082]-[0084], [0089], [0177], [0212]; fig. 1, 4	1-18
Y	US 20060084878 A1 TRIAGE WIRELESS, INC. 20 Apr 2006 (2006/04/20) para.[0010], [0031], [0032], [0044]; fig. 1A-1C, 5	1-18
<input type="checkbox"/> Further documents are listed in the continuation of Box C. <input checked="" type="checkbox"/> See patent family annex.		
* Special categories of cited documents: "A" document defining the general state of the art which is not considered to be of particular relevance "E" earlier application or patent but published on or after the international filing date "L" document which may throw doubts on priority claim(s) or which is cited to establish the publication date of another citation or other special reason (as specified) "O" document referring to an oral disclosure, use, exhibition or other means "P" document published prior to the international filing date but later than the priority date claimed "T" later document published after the international filing date or priority date and not in conflict with the application but cited to understand the principle or theory underlying the invention "X" document of particular relevance; the claimed invention cannot be considered novel or cannot be considered to involve an inventive step when the document is taken alone "Y" document of particular relevance; the claimed invention cannot be considered to involve an inventive step when the document is combined with one or more other such documents, such combination being obvious to a person skilled in the art "&" document member of the same patent family		
Date of the actual completion of the international search 26 Dec 2013		Date of mailing of the international search report 29 Dec 2013
Name and mailing address of the ISA: Israel Patent Office Technology Park, Bldg.5, Malcha, Jerusalem, 9695101, Israel Facsimile No. 972-2-5651616		Authorized officer COHEN Meytal  Telephone No. 972-2-5657820

**INTERNATIONAL SEARCH REPORT**  
Information on patent family members

International application No. PCT/IB2013/055633
--

Patent document cited search report	Publication date	Patent family member(s)	Publication Date
US 20060084878 A1	20 Apr 2006	NONE	
<hr/>			
WO 2009088930 A2	16 Jul 2009	CN 101952762 A	19 Jan 2011
		CN 101952762 B	28 Nov 2012
		CN 103033922 A	10 Apr 2013
		EP 2227711 A2	15 Sep 2010
		US 2011009163 A1	13 Jan 2011
		WO 2009088930 A2	16 Jul 2009
		WO 2009088930 A3	15 Oct 2009
<hr/>			

专利名称(译)	用于测量血液特征的装置，用于在具有数字传感器的主机设备上部署		
公开(公告)号	<a href="#">EP2872042A4</a>	公开(公告)日	2016-03-16
申请号	EP2013820443	申请日	2013-07-09
[标]申请(专利权)人(译)	CNOGA医疗		
申请(专利权)人(译)	CNOGA MEDICAL LTD.		
当前申请(专利权)人(译)	CNOGA MEDICAL LTD.		
[标]发明人	SEGMAN YOSEF		
发明人	SEGMAN, YOSEF		
IPC分类号	A61B5/145 A61B5/00 A61B5/1455		
CPC分类号	A61B5/6898 A61B5/14552 A61B5/6826 A61B5/683 A61B2560/0443		
优先权	13/549481 2012-07-15 US		
其他公开文献	EP2872042A1		
外部链接	<a href="#">Espacenet</a>		

#### 摘要(译)

一种用于与数字传感器，CPU和主机设备的显示器一起工作以便测量血液特征的装置，其包括被配置用于与主机装置相关联的壳体，以便在它们之间限定腔室，腔室中的至少一部分放置生物的附肢，使得附肢的尖端部署在数字传感器附近，以便覆盖数字传感器。腔室基本上包围数字传感器。来自光源的光被导向附肢尖端，其中来自光源的至少一些光被附肢的组织反射，由传感器接收，由此产生的数据由CUP处理以确定血液特征。