

(19) World Intellectual Property Organization  
International Bureau



(43) International Publication Date  
11 June 2009 (11.06.2009)

PCT

(10) International Publication Number  
WO 2009/070886 A1

(51) International Patent Classification:

A61B 5/11 (2006.01) A42B 3/04 (2006.01)  
G01P 1/12 (2006.01) F41H 1/04 (2006.01)  
G01P 21/00 (2006.01) G01L 5/14 (2006.01)

(21) International Application Number:

PCT/CA2008/002124

(22) International Filing Date:

8 December 2008 (08.12.2008)

(25) Filing Language:

English

(26) Publication Language:

English

(30) Priority Data:

60/996,855 7 December 2007 (07.12.2007) US

(71) Applicant (for all designated States except US): ALLEN-VANGUARD TECHNOLOGIES INC. [CA/CA]; 2400 St. Laurent Boulevard, Ottawa, Ontario K1G 6C4 (CA).

(72) Inventors; and

(75) Inventors/Applicants (for US only): HUBLER, Graham [US/US]; 6635 Prestwick Drive, Highland, Maryland 20777 (US). BYERS, Jeffrey [US/US]; 9109 John Way, Fairfax Station, Virginia 22039 (US). HOUSTON, Brian [US/US]; 4125 Doverville Lane, Fairfax, Virginia 22032 (US). CORSARO, Robert [US/US]; 5921 Walleye Court, Waldorf, Maryland 20603 (US). FRANK, Phil

[US/US]; 10524 Patuxent Ridge Way, Laurel, Maryland 20723 (US). KOST, Jason [US/US]; 9315 Wooden Glen Avenue, Burke, Virginia 22015 (US). OPACHKO, Kenny [TZ/US]; 4250 Airline Parkway, Shantilly, Virginia 20151 (US). BERDOZ, Alain [US/US]; 4236 Elizabeth Lane, Annandale, Virginia 22003 (US). HERDIC, Peter [US/US]; 1340 East Capitol Street, N.E., Washington, District Of Columbia 20003 (US). CHIN, Lock-Sui [CA/CA]; 71 Pinhey Street, Ottawa, Ontario K1Y 1T5 (CA). LEVINE, Jeffrey [CA/CA]; 152 Deerfox Drive, Nepean, Ontario K2J 4W6 (CA). DIONNE, Jean-Philippe [CA/CA]; 44 rue du Martine-Pecheur, Gatineau, Québec J9A 3A5 (CA). WONG, Doug [CA/CA]; 1425 Bortolotti Crescent, Ottawa, Ontario K1B 5C1 (CA). CROSSMAN, Daniel [CA/CA]; 45 Silver Horse Crescent, Kanata, Ontario K2M 2J2 (CA).

(74) Agent: SMART & BIGGAR; P.O. Box 2999, Station D, 900 - 55 Metcalfe Street, Ottawa, Ontario K1P 5Y6 (CA).

(81) Designated States (unless otherwise indicated, for every kind of national protection available): AE, AG, AL, AM, AO, AT, AU, AZ, BA, BB, BG, BH, BR, BW, BY, BZ, CA, CH, CN, CO, CR, CU, CZ, DE, DK, DM, DO, DZ, EC, EE, EG, ES, FI, GB, GD, GE, GH, GM, GT, HN, HR, HU, ID, IL, IN, IS, JP, KE, KG, KM, KN, KP, KR, KZ, LA, LC, LK, LR, LS, LT, LU, LY, MA, MD, ME, MG, MK, MN, MW,

[Continued on next page]

(54) Title: APPARATUS AND METHOD FOR MEASURING DATA FOR INJURY ANALYSIS

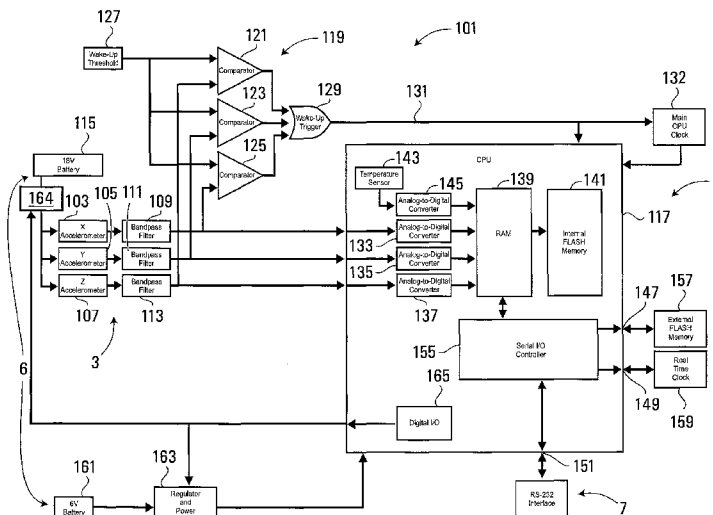

FIG. 7

(57) Abstract: An apparatus as provided for measuring acceleration of a person's head or other object. The apparatus comprises a sensor for sensing acceleration and a controller for controlling recording of data resulting from the sensed acceleration due to an explosive force. The controller is adapted to determine whether or not to enable recording of the data based on the sensed acceleration. A data receiver is provided to receive the sensed acceleration data from the sensing means, and requires electrical power to enable data to be received thereby. The controller controls electrical power to the receiver so that if the sensed acceleration reaches or exceeds a predetermined value, electrical power to the data receiver is enabled. The recorded acceleration data may be used for injury analysis.

WO 2009/070886 A1



MX, MY, MZ, NA, NG, NI, NO, NZ, OM, PG, PH, PL, PT, RO, RS, RU, SC, SD, SE, SG, SK, SL, SM, ST, SV, SY, TJ, TM, TN, TR, TT, TZ, UA, UG, US, UZ, VC, VN, ZA, ZM, ZW.

FR, GB, GR, HR, HU, IE, IS, IT, LT, LU, LV, MC, MT, NL, NO, PL, PT, RO, SE, SI, SK, TR), OAPI (BF, BJ, CF, CG, CI, CM, GA, GN, GQ, GW, ML, MR, NE, SN, TD, TG).

**(84) Designated States** (*unless otherwise indicated, for every kind of regional protection available*): ARIPO (BW, GH, GM, KE, LS, MW, MZ, NA, SD, SL, SZ, TZ, UG, ZM, ZW), Eurasian (AM, AZ, BY, KG, KZ, MD, RU, TJ, TM), European (AT, BE, BG, CH, CY, CZ, DE, DK, EE, ES, FI,

**Published:**

- *with international search report*
- *before the expiration of the time limit for amending the claims and to be republished in the event of receipt of amendments*

**APPARATUS AND METHOD FOR MEASURING DATA FOR INJURY ANALYSIS**Field of the Invention

The present invention relates to apparatus and methods for measuring and recording data from potentially injurious events to which humans may be exposed.

Summary of the Invention

Embodiments of the present invention provide a data recorder adapted for mounting on a combat helmet to measure and record parameters indicative of head acceleration resulting from violent events such as violent impact and blast events. Despite current designs of head protection, exposure of a large number of soldiers to detonation of improvised explosive devices (IEDs) has resulted in a high occurrence of blast-induced traumatic brain injuries (TBI). TBI has been noted to lead to injuries ranging from headaches and mild concussions to severe casualties including severe concussions and memory loss. The data recorder enables data from violent events to be recorded and used to build a database of head acceleration data induced by violent events which may be correlated with injuries suffered. The data recorded from violent events may be used to correlate injuries, especially brain injuries, with event characteristics and severity, including accumulated dosage and long-term and chronic symptoms. The analyzed data may be used to determine optimal medical treatment based on instant analysis of event data and/or making longer term medical decisions. The data may be used to assess effectiveness of protective equipment, both in helmet technology and other applications.

Embodiments of the data recorder provide a small, light-weight, self-contained digital recording system, capable of recording acceleration waveforms experienced in violent events. Embodiments of the data recorder are  
5 designed to mount on helmets and monitor and record exposure to potentially harmful cranial events. Embodiments of the datalogger enable both the direction and magnitude of acceleration to be measured. In some embodiments, the data recorder includes three accelerometers that are each only  
10 sensitive to accelerations in a single direction (axis). The accelerometers are mounted orthogonally to measure the vector components of acceleration in three-dimensional space. Embodiments of the data recorder enable acceleration to be measured by all three accelerometers simultaneously,  
15 with the vector sum of their signals indicating both the direction of the acceleration and the magnitude of acceleration.

Embodiments of the data recorder include a power management system for reducing the amount of power consumed  
20 by the device to extend the time over which the device can remain operational in the field. In particular, the power management system provides a means of switching part(s) of the data recorder between active and inactive states so that power required by those parts to perform a particular  
25 function is only provided when the particular function is to be performed.

Embodiments of the data recorder include a memory management scheme for managing the recording of data and which is capable of deciding which data to save and which to  
30 discard in order to reduce the amount of memory space required, and also how to use the available memory space to store the data efficiently and reduce power.

According to one aspect of the present invention, there is provided an apparatus for measuring acceleration of a person's head or other object, comprising sensing means for sensing acceleration, and a controller for controlling  
5 recording of data resulting from the sensed acceleration, wherein the controller is adapted to determine, based on the sensed acceleration, whether or not to enable recording of the data.

In some embodiments, the controller is adapted to  
10 enable recording of the data if the sensed acceleration meets a predetermined criteria, for example, if the measured acceleration reaches or exceeds a predetermined value. The predetermined or threshold value may be a finite value below a value that would or is likely to cause a predetermined  
15 injury to a person.

Some embodiments may be adapted to base the determination on any other characteristic of the sensed acceleration, for example, a time derivative of acceleration such as the slope of an impulse or Fourier frequency  
20 component(s) in the waveforms. This may enable even earlier detection of significant events.

In some embodiments, the apparatus comprises data receiving means for receiving sensed acceleration data from the sensing means, the receiving means requiring electrical  
25 power to enable the data to be received thereby, and wherein the controller causes electrical power to the receiving means to be controlled based on the sensed acceleration.

In some embodiments, the controller is adapted to determine whether or not the sensed acceleration meets a  
30 predetermined criteria, and if the criteria is not met, the controller causes the electrical power to be controlled such

that the receiving means is unable to receive the data. On the other hand, if the criteria is met, the controller is adapted to cause the electrical power to be controlled to enable the receiving means to receive the data.

5           Advantageously, the predetermined threshold value may be selected to provide sufficient time for the receiving means to change from an inactive state to an active state to receive acceleration data indicative of an injury.

10           In some embodiments, the receiving means comprises any one or more of signal conditioning means for conditioning the signal, an analog-to-digital converter, a processor and a memory. The memory may comprise a volatile memory such as a random access memory.

15           Embodiments of the apparatus may further comprise a second memory operatively coupled to the first memory for receiving data therefrom. The second memory may comprise a non-volatile memory or another memory requiring no power or less power than the first memory to hold data.

20           In some embodiments, the apparatus further comprises determining means for determining whether or not to transfer data from the first memory to the second memory. The determination may be based on the acceleration data. The determining means may be adapted to cause the data to be transferred from the first memory to the second memory, if  
25           the acceleration data meets a predetermined criteria. The predetermined criteria may be, for example, that a value of acceleration in the acceleration data (which may or may not be the peak acceleration) is likely to be sufficient to cause injury or has been previously determined to cause  
30           injury. At least one of the first and second memories may be an internal memory of a processor.

In some embodiments, the apparatus further comprises a third memory operatively coupled to the second memory for receiving data therefrom. A memory controller may be provided for controlling the transfer of data from the second memory to the third memory. The memory controller may be conditioned to transfer acceleration data from the second and third memory only if the second memory contains acceleration data from a plurality of separate events.

10 In some embodiments, the memory controller is adapted to transfer acceleration data relating to a plurality of different events from the second to the third memory in a single or the same write operation. Advantageously, this transfer scheme assists in reducing power since write operations can be power intensive. For example, the memory controller may be adapted to transfer acceleration data relating to three or more events in a single operation, for example, 5, 10, 15 or 20 or any other number.

20 In some embodiments, the apparatus further comprises monitoring means for monitoring the time of an acceleration event and means for recording acceleration data of an event and the time of the event. Advantageously, this arrangement allows acceleration data to be time stamped so that it can be correlated with other information that may be recorded about the event and which may assist in the compilation and analysis of injury data.

The acceleration sensor may be adapted to sense acceleration from an explosive force, and may for example, be capable of measuring forces of 1,500 gs or more, 5,000 gs or more, 10,000 gs or more or 15,000 gs or more.

In some embodiments, the data recording means is capable of recording acceleration waveforms having frequencies in the range of at least 500 to 1,000 Hz, or more.

5 In some embodiments, the data recording means is capable of changing from an inactive state to an active state in less than 1 millisecond, for example, less than 500 microseconds or less than 400, 300 or 200 microseconds, or in about 100 microseconds or less.

10 In some embodiments, the apparatus further comprises monitoring means for monitoring a power source for providing power to the apparatus.

In some embodiments, the apparatus further includes a temperature sensor for sensing the temperature of one or more components of the apparatus. As components of the data recorder, for example, the sensors, may be temperature dependent, measuring the temperature may assist in performing temperature compensation and increasing the accuracy of the measurements, where needed.

20 The data recorder may be adapted to be mounted to a helmet, for example, to the helmet shell, for example on the outside of the shell. The data recorder may be adapted for releasably fastening to the helmet so that it can be readily removed therefrom and replaced, as necessary.

25 According to another aspect of the present invention, there is provided an apparatus for measuring a parameter resulting from exposure of a person to a physical event, comprising sensor means for sensing said parameter, determining means for determining a relationship between the value of the sensed parameter and a predetermined value of

30

said parameter, and a controller responsive to the determining means for controlling a device in response to the determination made by the determining means.

According to another aspect of the present invention, there is provided an apparatus for measuring acceleration of a person's head resulting from exposure of the head to a force, the apparatus comprising sensing means for sensing said acceleration, determining means for determining a relationship between the value of the sensed acceleration and a predetermined value of acceleration, and a controller responsive to said determining means for controlling a device in response to the determination made by the determining means.

In some embodiments, the sensing means comprises an accelerometer for measuring acceleration in three mutually orthogonal directions.

In some embodiments, the relationship determined by said determining means is whether or not the sensed value of acceleration is equal to or exceeds the predetermined value.

In some embodiments, the predetermined value is below a value determined to cause a predetermined degree of injury.

In some embodiments, the device comprises a power controller, a memory, a processor, an indicator or another device.

In some embodiments, the device comprises a recording means for recording the value of the sensed parameter.

In some embodiments, the apparatus includes mounting means for mounting the apparatus to a protective helmet.

Advantageously, the apparatus allows head  
5 acceleration to be measured only when it is determined that the sensed acceleration is sufficient to actually warrant recording the measurement thereby reducing the electrical power requirements and extending the useful life of the system when powered by a battery.

10 According to another aspect of the present invention, there is provided an apparatus for recording data indicative of acceleration of a part of a person's body or other object, comprising first memory means for receiving acceleration data from an acceleration sensor, second memory  
15 means operatively coupled to the first memory means for receiving data from the first memory means, and a data transfer controller for controlling the transfer of data from the first memory means to the second memory means based on the acceleration data.

20 According to another aspect of the present invention, there is provided a method of calibrating a data recording unit for measuring head acceleration, comprising the steps of: (a) providing a data recording unit mounted to a head protector; (b) mounting the head protector on a  
25 support; (c) subjecting the head protector to a force or change in pressure; (d) measuring acceleration of the head protector resulting from the force or change in pressure; (e) measuring acceleration of the support resulting from the force or change in pressure; and (f) determining a  
30 relationship between the measured acceleration of the head protector and the support.

According to another aspect of the present invention, there is provided a method of determining the value of a parameter indicative of acceleration of a person's head, comprising the steps of: acquiring data  
5 measured by an acceleration sensor mounted to a head protector and using a calibration method to determine from the data the value of said parameter.

According to another aspect of the present invention, there is provided a method of monitoring  
10 acceleration of a part of a body of military or service personnel comprising mounting a monitor for monitoring acceleration to the body part to be monitored.

Embodiments of the method may include any one or more additional features disclosed herein.

#### 15 Brief Description of the Drawings

Examples of embodiments of the present invention will now be described with reference to the drawings, in which:

Figure 1 shows a front perspective view of a data  
20 recording unit according to an embodiment of the present invention, mounted to the rear of a military helmet;

Figure 2 shows a front perspective view of the data recording unit of Figure 1 in more detail;

Figure 3 shows a rear perspective view of the data  
25 recording unit shown in Figures 1 and 2;

Figure 4 shows a semi-transparent view of some of the circuitry of the data recording unit of Figures 1 to 3;

Figure 5 shows a front perspective view of the data recording unit encapsulated in a mold;

Figure 6 shows a rear perspective view of a molded cover for the data recording unit;

5 Figure 7 shows a block diagram of components of a data recording unit according to an embodiment of the present invention;

Figure 8 shows an example of both unfiltered and filtered head acceleration traces in the x-direction (front-  
10 back) of a forward facing mannequin towards an explosion at a standoff distance of 3 meters, provided by 8.5 pounds of C4;

Figure 9 shows an example of both unfiltered and filtered x-direction helmet acceleration traces as recorded  
15 by a data recording unit from a forward-facing mannequin during the explosion of Figure 8;

Figure 10 shows an example of filtered head acceleration traces for x, y (left-right) and z (up-down) directions, and the resultant acceleration trace for the  
20 same forward-facing mannequin and explosion of Figures 8 and 9;

Figure 11 shows examples of x, y and z direction, filtered acceleration traces and a resultant acceleration trace as measured by a helmet-mounted data recording unit  
25 for the same forward-facing mannequin and blast event of Figures 8 to 10;

Figure 12 shows resultant, filtered head acceleration traces for a forward-facing mannequin during

2.5 pounds, 4.0 pounds, 8.5 pounds and 12.5 pounds of C4 charges at a standoff distance of 3 meters;

Figure 13 shows an example of resultant filtered acceleration traces as measured by a helmet mounted data recording unit for the forward-facing mannequin of Figure 12 during the 2.0 pounds, 4.0 pounds, 8.5 pounds and 12.5 pounds C4 charges at a standoff distance of 3 meters;

Figure 14 shows an example of resultant, filtered head acceleration traces for a mannequin oriented in different directions with respect to 8.5 pound, C4 charges at a standoff distance of 3 meters; and

Figure 15 shows examples of acceleration traces as measured by a helmet mounted data recording unit for the mannequin of Figure 14 at different orientations with respect to the explosive charge.

#### Detailed Description

Referring to Figures 1 to 7, a data recording unit 1 according to an embodiment of the present invention comprises a sensor 3 for sensing acceleration, and circuitry 5 (Figure 7) for recording acceleration data. The unit includes a source 6 of electrical power, which may comprise one or more battery cells, for example, cells 6a to 6h, which may be standard "coin" cells. A communication port 7 may be provided for connection to and/or communication with an external device. Components of the data recording unit may be mounted on a circuit card assembly 8 which may be subsequently encapsulated in an epoxy mold 9 to form an integral unit 11. A cap 13 is provided to cover the front and peripheral edge of the unit and the unit and cap are mounted on a protective helmet 15,

as shown in Figure 1. In this embodiment, the rear face 17 of the unit generally conforms to the shape of the part of the helmet against which it is mounted. The unit may be designed to be mounted on the rear part of a helmet, 5 although in other embodiments, the unit may be mounted on any other part of the helmet. A through hole 19 is provided through the unit and cap for receiving a mounting bolt or screw to secure the unit to the helmet shell. The through hole may be positioned to coincide with the position of an 10 existing through hole in the helmet, for example, for mounting the internal suspension system, avoiding the need for making any additional holes in the helmet which might compromise its protective performance. In this embodiment, the unit includes a clip 21 which is adapted to clip under 15 the lower peripheral edge of the helmet to assist in retaining the unit to the helmet, and may be integrally formed with the cap. In other embodiments, the clip may be integrally formed with the epoxy layer or mold, or may comprise a separate piece. In this embodiment, the cap is 20 provided with internal projections 23, 25 which register with corresponding apertures 27, 29 formed in the unit 11 to assist in locating the cap on the unit and preventing relative movement between the two.

In other embodiments, alternative or additional 25 fastening means may be provided to securely fasten the data recording unit to the helmet.

The data recording unit comprises an acceleration sensor, discrimination circuitry for determining whether or not the measured acceleration is at or exceeds a 30 predetermined value, and circuitry responsive to the discrimination circuitry for recording measured values of acceleration.

A block diagram of an example of a data recording unit is shown in Figure 7. Referring to Figure 7, the data recording unit 101 includes first, second and third accelerometers 103, 105, 107, each of which measures  
5 acceleration in a single direction which is orthogonal to the acceleration direction measured by the other two accelerometers. The accelerometers may be arranged so that they each lie on a respective one of three mutually  
10 orthogonal axes in which all of the axes meet at a common point, to assist in resolving the actual direction of acceleration from the acceleration trace produced by each accelerometer. In this embodiment, the first  
accelerometer 103 measures acceleration in the front-back (designated x) direction, the second accelerometer 105  
15 measures acceleration in the left-right (designated y) direction, and the third accelerometer 107 measures acceleration in the up-down (designated z) direction. In some embodiments, the accelerometers use transducers that produce or generate an electrical signal in response to  
20 sensing acceleration, without the transducers requiring electrical power to do so, in order to help reduce power requirements. In some embodiments, the accelerometers use transducers that exploit the Piezo-electric effect to generate a charge whose value varies with acceleration and  
25 may be proportional to acceleration, for example.

A respective band pass filter 109, 111, 113 may be provided for filtering the signal from each  
accelerometer 103, 105, 107. A respective amplifier (not shown) may be provided to amplify each accelerometer signal,  
30 either before or after the band pass filter, or both. In some embodiments, the amplifiers may be very low power op-amps to help minimize the amount of power required by the sensor circuitry. Electrical power for the sensor circuitry

is provided by a suitable power source 115, which may comprise one or more individual battery cells.

The data recording unit includes a data processing unit 117 for receiving acceleration signals from the accelerometers 103, 105, 107, and a control or discriminating circuit 119 for controlling the state of the data processing unit 117 to manage the power drawn by the unit. In particular, the control circuit 119 is arranged to control the data processing unit 117 between a first, inactive state in which the data processing unit is in "sleep" mode and draws no or little power and is unable to record acceleration data, and a second state in which the data processing unit is in "an awake" mode or active state and able to record acceleration data. In this embodiment, the control circuit 119 comprises a respective comparator 121, 123, 125 coupled to receive acceleration signals from a respective accelerometer and for comparing the magnitude of the acceleration signals with a predetermined value. In this particular embodiment, one input of each comparator is coupled to receive a respective accelerometer signal from a respective band pass filter and another input of each comparator is coupled to receive the threshold value provided by a suitable source 127. The output of each comparator is coupled to a suitable logic device or circuit, for example, an OR gate 129 which is arranged to output a trigger signal 131 to the data processor unit 117 to cause the data processing unit to change from an asleep state to an awake state if the acceleration measured by any one of the accelerometers reaches or exceeds the predetermined threshold value. A main clock 132 provides clocking signals to the data processing unit, and, in this embodiment, is an external clock, although in other embodiments, the clock may be

internal of the CPU. The trigger signal 131 is provided to the main clock 132 to control operation thereof, as described in more detail below.

Some embodiments may be adapted to base the determination as to whether or not to enable the data recording unit to receive and record acceleration data on any other characteristic of the sensed acceleration. These may include any one or more of a time derivative of acceleration, such as the slope of an impulse, or Fourier frequency component(s) in the waveforms. A derivative circuit may be provided to monitor the slopes of impulses, or appropriate circuitry may be provided to perform a Fourier analysis on the waveform, and to determine whether the resulting values meet a predetermined criteria. This may allow even earlier detection of significant events.

The data processing unit 117 includes first, second and third analog-to-digital converters 133, 135, 137 for receiving acceleration signals from a respective accelerometer 103, 105, 107, a first memory unit 139 for recording digital acceleration data from each A to D converter 133, 135, 137, and a second memory unit 141 for receiving data from the first memory unit 139. The first memory unit may comprise a volatile memory, e.g. a random access memory (RAM) and the second memory unit may comprise a non-volatile memory, for example, a FLASH memory. The data processing unit 117 may also include a temperature sensor 143 and possibly a fourth analog to digital converter 145 for receiving an analog signal indicative of temperature from the temperature sensor and passing a corresponding digital signal to the first memory unit 139 to be recorded therein. The data processing unit also includes one or more interface(s) 147, 149, 151 for communicating and

exchanging signals with one or more external device(s), and an I/O controller 155 for controlling the transfer of data between internal memory of the data processing unit 117 and external device(s).

5           The data recording unit includes an external memory 157 and a real time clock 159 coupled to a respective interface 147, 149 of the data processing unit 117 and which are capable of communicating with its internal memory 139 via the I/O controller 155. The real time clock provides an  
10 indication of real time (e.g. including any one or more of year, month, day and time, (e.g. hour, and optionally minute and optionally second) and enables event data to be time-stamped. Time-stamping enables the event to be correlated with other information or record(s) of an event. One of the  
15 interfaces of the data processing unit 151 includes a general interface port adapted for releasable connection to a peripheral device, such as a host computer. In the present embodiment, the interface 155 is an RS-232 interface, although in other embodiments, the interface 151  
20 may comprise any other suitable interface, for example, a USB.

          The data recording unit also includes a power source 161 for providing electrical power to the data processing unit. Regulator and power management  
25 modules 163, 164 are provided for regulating power to the data processing unit and the acceleration sensor circuitry, respectively. In this particular embodiment, the regulator and power management modules 163, 164 are coupled to an interface 165 (e.g. a digital I/O interface) of the data  
30 processing unit. In some embodiments, the regulator and power management modules 163, 164 may each comprise a switch, which switchably couples/decouples the power sources

to/from the data processing unit 117 and sensor circuitry in response to a control signal from the interface 165. Each power management module may be controlled independently of the other, or may be controlled together, for example using  
5 the same control signal. The switch may enable the respective power sources to be completely disconnected from their associated circuitry (load), so that substantially no power is drawn when the unit is in storage, for example.

#### Power Management

10           Embodiments of the data recording unit are designed to operate continuously for extended periods of time using stored electrical energy from a battery, for example, without any requirement for recharging, and the associated infrastructure, or replacing the battery. Some  
15 embodiments are designed to operate continuously for the duration of a typical "tour of duty" for military personnel which may last for up to six months, or more. In normal operation, i.e. in the absence of exposure to a violent event, components which are required to record data are  
20 maintained in an "off" or inactive state where little or no power is drawn by those components. In this state, only the acceleration sensors, their associated circuitry (i.e. op-amps and band pass filters) and the control circuit 119 are active. In some embodiment, the comparators 121, 123, 125  
25 of the control circuit are selected to draw little power.

The earliest stages of a blast event are critical in determining potential injury as this is when the maximum acceleration(s) occur. Typically, a subject is exposed to maximum acceleration values in the first few milliseconds of  
30 a blast event, for example, the first one or two milliseconds. The largest acceleration impulses are usually

the first to arrive, and these initial impulses may only last one or two milliseconds. An example of the acceleration of the head of an anthropomorphic mannequin measured during a blast event is shown in Figure 8. In this example, the mannequin's head is facing forwards towards the blast which is generated by a charge containing 8.5 pounds of C4 at a distance from the mannequin of 3 meters. The graph shows two x-direction (front-back) acceleration traces, one being an unfiltered trace and the other being filtered by a band pass filter which cuts off frequencies above about 1,650 Hertz. As can be seen, the peak acceleration occurs at about 0.5 milliseconds or 500 microseconds after the point at which the acceleration first begins to change. This peak acceleration only lasts for about 1 millisecond. Figure 9 shows an example of filtered and unfiltered x-direction acceleration traces from the same blast event as that of Figure 8, as measured by a data recording unit mounted to a helmet fitted on and secured to the mannequin's head. Again, the peak acceleration occurs within the first 500 microseconds and has a duration of about 1 millisecond. As described below, embodiments of the data recording unit are capable of switching from an inactive to an active state in response to acceleration measured by the sensors in a sufficiently short time to enable at least part of the earliest acceleration impulse, which may be the strongest, to be recorded.

When an event of interest occurs, such as an impact event or a blast event, as determined by the acceleration measured by one or more accelerometers reaching or exceeding the threshold value, a trigger signal 131 is output from the control circuit 119 and causes the data processing unit 117 to turn on and start recording. The threshold value may be set at about 50 gs, for example, or

any other suitable value. In some embodiments, the data processing unit is triggered to start by an acceleration from any one or more of the acceleration sensors which exceeds a pre-set threshold. In some embodiments, the acceleration trigger threshold is set slightly below levels where injury is expected to occur. Advantageously, this provides sufficient time for the data processing unit to start up and capture the relevant acceleration waveforms. The data processing unit may employ a rapid start up system to jump from a deep sleep mode to full execution mode in a relatively short time, for example, about 100 microseconds.

Although in some embodiments, activation of the data processing unit may be controlled by switchably connecting the data processing unit to the power source, other embodiments of the data recording unit use one or more other techniques for rapid startup, an example of which controls startup through the main CPU clock. In one embodiment, the frequency of the main clock can be varied between one or more operating frequencies, for example, 5.5 MHz (or any other suitable frequency) and a frequency of 0 Hz, for example. This may be implemented by switching the clock between ON and OFF states, for example in response to the trigger signal from the control circuit 119. In one embodiment, the clock may comprise a solid state oscillator rather than a crystal oscillator to enable the clock to start quickly, for example in one or two clock cycles, which for a clock frequency of 5.5 MHz would take about 0.2 to 0.4 microseconds. When the main clock is in the OFF state, the CPU effectively sees that the clock has stopped, ceases to execute the current instruction and holds its current state. Although power to the data processing unit is available, power is conserved when the

data processing unit is in the "inactive" state, and execution of instructions is suspended.

On receiving a trigger or control signal from the control circuit 119, the clock turns ON and provides a  
5 clocking signal to the data processing unit which, in response, becomes active and begins to execute instructions. Advantageously, controlling the data processing unit between active and inactive states using the main clock rather than  
10 switchably ON/OFF coupling the data processing unit to the power source reduces the amount of power required to activate the data processing unit.

In some embodiments, power for activating or driving the main CPU clock is provided both by the control signal 131 and the data processing unit. In a specific  
15 embodiment, the trigger signal lasts for a sufficient time to power the clock on until power for the clock can be supplied by the data processing unit. Any suitable means may be provided to maintain the control or trigger signal 131 at an appropriate level to provide power to the  
20 clock for a sufficient period of time until the data processing unit has started and can provide power to the clock. The means may for example be provided by an appropriate filter. In some embodiments, once the data processing unit receives an appropriate clocking signal from  
25 the main clock, the data processing unit executes a relatively short "house-keeping" program, which may include an instruction to provide power to the main clock. Once active, the data processing unit is able to receive and convert analog accelerometer signals to digital signals and  
30 record the digital signals.

In some embodiments, the data recording unit is adapted to record data for a predetermined length of time, for example, any time from about 1 to 15 milliseconds or any other suitable time, e.g. a length of time that is

5 sufficient to record the maximum acceleration only or the latter plus a predetermined additional time. The data processing unit may also be adapted to maintain itself in the active state for a predetermined period of time and then cause itself to change to an inactive state to conserve

10 power. This may be implemented, for example, by configuring the data processing unit to turn off power to the clock a predetermined period of time after the CPU becomes active. Once in the inactive state, the data processing unit remains in that state until another acceleration event causes the

15 data processing unit to change to the active state.

In the present embodiment, the analog waveform from each sensor is converted by a respective A to D converter to a digital signal and stored in the first, volatile memory unit 139. The A to D converters may be

20 adapted to operate at any desired sampling rate, for example, 10 kHz or any other suitable frequency. The band pass filters may be configured to ensure that the signals to the A to D converters do not fluctuate faster than half the A to D sampling frequency to reduce frequency and amplitude

25 errors in the digitized waveforms. Each of the first, second and third A to D converters may be adapted to convert simultaneously so that the direction of each instantaneous acceleration can be determined efficiently. When an event occurs in which the acceleration is sufficient to activate

30 the data recorder, acceleration data is received by the first memory unit and recorded therein with the time of the event, as provided by the real time clock 159, and the temperature from the temperature sensor 143. After

capturing an event in the first memory unit 139, the data processing unit may be adapted to make a decision either to store or not to store the data in non-volatile memory, based, for example, on the measured acceleration. Such a determination may be made based on whether a peak  
5 acceleration exceeds an injury threshold or not. The data recording unit may be provided with one or a plurality of such threshold(s). The threshold(s) may be set by an external computer, via a suitable interface, for example,  
10 interface 151. In one embodiment, a threshold may be set at 100 gs, for example, or any other suitable value.

If the decision by the data processing unit is to retain the data stored in the volatile memory 139, data is then transferred from the volatile memory to the non-  
15 volatile memory unit 141, where the data may be stored indefinitely without requiring electrical power. Once the data has been transferred from the first to the second memory unit, the data processing unit shuts itself down, entering a "sleep" state, and waits for the next event. If  
20 the data processing unit decides not to keep the event data, the data processing unit shuts itself down without transferring the event data to non-volatile memory, resulting in the loss of the data recorded in the volatile memory 139.

25 As described above, the data recording unit may be adapted to enable electrical power to one or more of the acceleration sensors and/or the data processing unit to be turned on or off to extend battery life. This feature may be used to prolong battery-shelf-life so that the unit can  
30 be activated only when it is brought into service rather than during periods of storage or non-use. For this purpose, the data recording unit may include a switch which

may be manually accessible on the device or a switch (e.g. power management module 163, 164) accessible via a communications port or interface, for example interface 151. In this latter case, an external control signal may cause  
5 the switching module 163, 164 to change state from OFF to ON and the switching module may be adapted to maintain itself in the ON-state thereafter without further application of the control signal. Electrical power to the unit may be switched off in a similar manner.

10           Electrical power may be provided to the data recording unit other than via the batteries to enable the data processing unit to be turned on and data downloaded from the internal non-volatile memory 141 and/or the external memory 157. Advantageously, this feature allows  
15 data to be retrieved in the event that the batteries no longer have sufficient energy to activate the unit for this purpose.

#### Memory Management

As described above, in the present embodiment,  
20 memory associated with the data recording unit includes a first memory unit 139 for receiving and recording data from the A to D converters, a second memory unit 141 for receiving and storing data from the first memory unit, and an external memory unit 157. In some embodiments, the first  
25 memory unit comprises a random access memory to capture and store high speed samples from the A to D converters and to keep the data until a decision has been made as to whether to save it. To reduce power consumption, data which is to be saved is transferred to the second, non-volatile memory  
30 unit. The second memory unit 141 may have the capacity to store simultaneously event data from a number of separate

events. In some embodiments, data stored in the second memory unit may be transferred to the external memory unit 157. In some embodiments, data from a number of separate events may be transferred from the second memory unit 141 to the external memory unit 157 in a single or the same write operation to reduce the power which would otherwise be required if data from each event is transferred in separate, discrete write operations. In some embodiments, the data processing unit is adapted to control the transfer of data from the second memory unit to the external memory unit once a predetermined number of events have been recorded in the second memory unit. In one embodiment, the data processing unit may be arranged to transfer data only when more than three, for example, ten events have been accumulated and to transfer those (ten) events in a single write operation. In other embodiments, the number of accumulated events prior to transfer may be any other number and the number of events transferred in a single write operation may also be any other number, and not necessarily the same number as the number of accumulated events. Preferably event data for more than one event is transferred in a single write operation.

In some embodiments, the non-volatile memory comprises a solid-state memory to withstand the high forces experienced by the data recording unit. The amount of memory may be limited to conserve electrical power, reduce size and save weight. The non-volatile memory of the data processing unit may comprise a flash memory, for example, an electrically erasable programmable read-only memory (EEPROM), and may be used to store firmware and accumulate data from a plurality of events before the data is archived to the external memory. The external memory may also comprise a solid state flash memory.

In some embodiments, other data may be stored in one or more of the available memories. This may include data which is specific to the data recording unit to enable the data recording unit to operate and/or recorded data to be processed. The data may include offset value(s) for the acceleration sensor(s). For example, a sensor may provide a non-zero output in the absence of any acceleration. Offset values may be used by the control circuit 119 to modify/correct the threshold value that controls activation of the data processing unit, and/or to modify/correct threshold values used to determine whether to keep the recorded data or not. The values may include multiplication factor(s) resulting from any signal amplifiers, or other conditioning. The data may be available to be output to an external device via a suitable interface for subsequent use, which may include correcting/adjusting recorded data for analysis and/or other processing. Storing such values in or with the unit is particularly convenient, as it obviates the need for the values to be stored elsewhere, for example in a central database, their associated input thereto, which may be prone to error, and their maintenance therein.

### Sensors

In addition to acceleration sensors, the data recording unit may include a temperature sensor. The temperature sensor may be included in the data processing unit or may be separate therefrom. Since the accelerometer sensors may exhibit some temperature dependence, providing a temperature sensor enables temperature compensation to be performed on the data to improve accuracy of the measurement, if required.

Embodiments of the data recorder may include a communication port for enabling data to be downloaded to an external device. The port may be one which requires a physical wireline connection. In some embodiments, the data recorder may include a wireless interface for communicating with an external device to enable, for example, data to be downloaded using a wireless connection. In some embodiments, the protocol used for transferring data may enable secure data transfer over short ranges with efficient, low power operation. The protocol may be based on the IEEE 802.15.4 Standard for the physical and media access control layer, an example of which is known as ZIGBEE. The protocol may also allow data to be downloaded from a number of separate data recording units.

Embodiments of the data recording unit may include an optional indicator, which may comprise a visual indicator such as a red or green light or both to indicate if power to the unit is turned on, thereby confirming that the unit is ready to record events.

Figure 10 shows an example of filtered acceleration traces for the x, y and z directions measured by accelerometers mounted in the head of a mannequin together with the resultant acceleration trace derived from the x, y and z direction acceleration traces. The measurements were made during the same blast event of Figures 8 and 9, i.e. with the mannequin's face facing forward towards an 8.5 pound C4 charge at a distance of 3.0 meters. As can be seen, the peak of the resultant acceleration experienced by the mannequin's head occurs within the first 1 or 2 milliseconds of the blast.

Figure 11 shows filtered acceleration traces in the x, y and z directions as measured by an embodiment of a data recording unit mounted to a helmet and worn by and secured to the mannequin's head for the same blast event as Figures 8 to 10, together with the resultant acceleration trace derived from each of the measured x, y and z acceleration traces. Again, the peak acceleration or accelerations of the helmet occur within the first one or two milliseconds of the blast. The magnitude of the peak acceleration of the helmet is higher than the peak acceleration of the mannequin's head. This is at least partly due to the mechanical decoupling between the head and helmet provided by the resilient or flexible helmet suspension or cushioning system, which allows relative movement between the head and helmet, and the difference in mass between the head and helmet. In practice, for head acceleration monitoring, acceleration may be measured by helmet mounted accelerometers only. In order to derive head acceleration from a helmet mounted data recording unit, calibration tests may be performed in order to determine a relationship describing or defining the correlation between helmet and head accelerations. Such a determination may be made by performing a number of measurements with the head/helmet combination subjected to different blast strengths, which may be varied, for example, by either changing the strength of the blast or the distance between the explosive and the mannequin.

Figures 12 and 13 show resultant acceleration traces for head and helmet accelerations, respectively, measured for four blast events using different quantities of explosive at the same standoff distance of 3 meters. In determining the correlation between head and helmet accelerations, the peak (or other value of) acceleration may

be obtained from each acceleration trace and the ratio between peak head and peak helmet accelerations may be determined. A mathematical expression may then be fitted to the data, thereby establishing a relationship between head  
5 and helmet accelerations. This relationship may then be used when analyzing data from the data recording unit to determine head acceleration. This data may be used to determine a level of injury that may have been caused by the blast event. For example, previous studies carried out by  
10 the applicant, in which anthropomorphic mannequins have been subjected to the blast of high explosives in free field (no obstacles) conditions, have indicated that the blast-induced head acceleration injury threshold corresponds to a peak resultant head acceleration of the order of 450 gs.

15           The inventors have found that both head and helmet acceleration depend on the orientation of the head/helmet combination relative to the source of the blast. In addition, the inventors have found that the ratio between head acceleration and helmet acceleration may also depend on  
20 the orientation of the head/helmet combination relative to the source of the explosion. Figure 14 shows examples of resultant head acceleration traces measured for four different mannequin orientations: (1) the front of the mannequin faces the explosive source; (2) the back and side  
25 of the mannequin are directed towards the explosive source, with a line extending between front and back of the mannequin at 45° to the source; (3) the side of the mannequin is directed towards the explosive source; and  
(4) the back of the mannequin is directed towards the  
30 explosive source. As can be seen from the traces, the peak acceleration varies depending on the orientation, with the highest peak acceleration values resulting from the side and

45° orientations and the lowest peak acceleration values resulting from the back orientation.

Figure 15 shows resultant acceleration traces measured by a helmet mounted data recording unit for the same orientations and blast events of Figure 14. As can be seen, the highest acceleration value results from a side orientation, the second highest acceleration results from the back orientation, the third highest results from front orientation and the lowest acceleration peak results from the 45° orientation. This shows that the ratio between head and helmet acceleration varies depending on the orientation of the head relative to the explosive source. The relationship between head and helmet acceleration may be determined for any number of different orientations and subsequently used to determine head acceleration from data recorded by the helmet mounted data recording unit. For example, the acceleration traces measured by the accelerometers of the data recording unit provide the direction of the blast relative to the head/helmet combination from which the orientation of the helmet relative to the explosive source can be determined. The orientation value can then be used to look up a value of the ratio or other relationship between head and helmet acceleration and the ratio or other relationship then used to determine head acceleration from the value of acceleration measured by the data recording unit. The determined head acceleration value may then be used to determine whether or not an injury has occurred and possibly the level of injury.

In other embodiments and aspects of the invention, any feature disclosed herein may be omitted altogether or substituted by another feature which may or may not be an

equivalent or variant thereof. For example, in some  
embodiments, the z-direction accelerometer may be omitted.  
This may be appropriate if the azimuthal direction of  
acceleration (i.e. the direction in the horizontal plane)  
5 only is of interest.

Embodiments of the data recorder may be mounted on  
any object. For example, it may be mounted on a vehicle or  
a stationary object, or on any article of apparel to be  
worn by a person.

10 Embodiments of the data recorder may be capable of  
measuring accelerations having values of at least 1,500 gs,  
for example, 5,000, 10,000 or 15,000 gs or more.

Other aspects and embodiments of the invention  
comprise any feature disclosed herein in combination with  
15 any one or more other feature disclosed herein or a generic  
or specific equivalent or variant thereof.

Any embodiment may comprise sensor means for  
measuring rotational motion, for example, rotational  
acceleration. The sensor means may comprise a plurality of  
20 spaced apart sensors (e.g. accelerometers) located at  
different positions either within a data recording unit, or  
one or more sensors may be separate from the unit and  
mounted on the object to be monitored, for example, on a  
head protector.

25 The data recording unit may record data from the  
rotational sensor(s). Recording and storing the data may be  
performed using the same or similar methodology to that  
disclosed herein in relation to the axial acceleration data.

Numerous modifications to the embodiments described above will be apparent to those skilled in the art.

CLAIMS:

1. An apparatus for measuring acceleration of a person's head or other object, comprising sensing means for sensing acceleration, and a controller for controlling  
5 recording of data resulting from the sensed acceleration, wherein the controller is adapted to determine whether or not to enable recording of the data based on the sensed acceleration.
2. An apparatus as claimed in claim 1, wherein said  
10 controller is adapted to enable recording of the data if the sensed acceleration meets a predetermined criteria.
3. An apparatus as claimed in claim 2, wherein said predetermined criteria comprises one of: (1) the sensed acceleration reaches a predetermined value and (2) the  
15 sensed acceleration exceeds a predetermined value.
4. An apparatus as claimed in claim 3, wherein said predetermined value is a value above zero and below a value that would or is likely to cause a predetermined injury to a person.
- 20 5. An apparatus as claimed in any one of claims 1 to 4, further comprising data receiving means for receiving sensed acceleration data from the sensing means, the receiving means requiring electrical power to enable the data to be received thereby, and wherein said controller  
25 causes electrical power to said receiving means to be controlled based on the sensed acceleration.
6. An apparatus as claimed in claim 5, wherein said controller is adapted to determine whether or not the sensed acceleration meets a predetermined criteria, and if the  
30 criteria is not met, the controller causes the electrical

power to be controlled such that said receiving means is unable to receive said data.

7. An apparatus as claimed in claim 6, wherein, if said criteria is met, said controller causes the electrical power to be controlled to enable said receiving means to receive said data.

8. An apparatus as claimed in claim 5, wherein said controller is adapted to determine whether or not the sensed acceleration meets a predetermined criteria, and if the criteria is met, the controller causes the electrical power to be controlled to enable the receiving means to receive said data.

9. An apparatus as claimed in any one of claims 6 to 8, wherein said predetermined criteria is one of: (1) that the sensed acceleration reaches a predetermined value and (2) that the sensed acceleration reaches and exceeds a predetermined value.

10. An apparatus as claimed in claim 9, wherein the predetermined value is above zero and below a value that would or is likely to cause a predetermined injury to a person.

11. An apparatus as claimed in claim 10, wherein said predetermined injury is a predetermined head injury.

12. An apparatus as claimed in claim 11, wherein said predetermined head injury is a predetermined brain injury.

13. An apparatus as claimed in any one of claims 6 to 12, wherein said predetermined value is selected to provide sufficient time for said receiving means to change from an inactive state to an active state to receive one or both of

(1) data indicative of the maximum acceleration associated with an event and (2) acceleration data indicative of an injury.

14. An apparatus as claimed in any one of claims 5 to 5 13, wherein said receiving means comprises any one or more of signal conditioning means for conditioning the signal, an analog to digital converter, a processor and a memory.

15. An apparatus as claimed in claim 14, wherein said memory comprises a random access and/or volatile memory.

10 16. An apparatus as claimed in claim 14 or 15, further comprising a second memory operatively coupled to said first memory for receiving data therefrom.

17. An apparatus as claimed in claim 16, wherein said second memory is a non-volatile memory or another memory 15 requiring no power or less power than the first memory to hold data.

18. An apparatus as claimed in claim 16 or 17, further comprising determining means for determining whether or not to transfer data from said first memory to said second 20 memory based on said acceleration data.

19. An apparatus as claimed in claim 18, wherein said determining means is adapted to cause said data to be transferred from said first memory to said second memory if said acceleration data meets a predetermined criteria.

25 20. An apparatus as claimed in claim 19, wherein said predetermined criteria is that a value of acceleration in said acceleration data is likely to be sufficient to cause injury or has been previously determined to cause injury.

21. An apparatus as claimed in any one of claims 16 to 20, wherein at least one of said first and second memories is an internal memory of a processor.

22. An apparatus as claimed in any one of claims 16 to 5 21, further comprising a third memory operatively coupled to said second memory for receiving data therefrom.

23. An apparatus as claimed in claim 22, further comprising a memory controller for controlling the transfer of data from said second memory to said third memory.

10 24. An apparatus as claimed in claim 23, wherein said memory controller is conditioned to transfer acceleration data from said second memory to said third memory only if said second memory contains acceleration data from a plurality of separate events.

15 25. An apparatus as claimed in claim 23 or 24, wherein said memory controller is adapted to transfer acceleration data relating to a plurality of different events from said second memory to said third memory in a single or the same write operation.

20 26. An apparatus as claimed in claim 25, wherein said memory controller is adapted to transfer acceleration data relating to between 3 and 20 events or more in a single operation.

25 27. An apparatus as claimed in any one of claims 1 to 26, further comprising monitoring means for monitoring the time of an acceleration event and means for recording acceleration data of an event and the time of the event.

28. An apparatus as claimed in any one of claims 1 to 27, further comprising a temperature sensor for sensing the temperature of one or more components of the apparatus.

29. An apparatus as claimed in claim 28, further  
5 comprising recording means for recording acceleration data relating to an acceleration event and for recording the temperature at the time of the event.

30. An apparatus as claimed in any one of claims 1 to 29, wherein said sensing means comprises a plurality of  
10 sensors each capable of measuring acceleration in a single direction and configured to measure acceleration in a direction which is mutually perpendicular to the direction of one or more other acceleration sensors.

31. An apparatus as claimed in claim 30, wherein said  
15 control means comprises a plurality of comparators each for comparing acceleration sensed by a respective acceleration sensor with a predetermined value.

32. An apparatus as claimed in any one of claims 1 to 30, wherein said control means comprises a comparator for  
20 comparing the sensed acceleration with a predetermined value.

33. An apparatus as claimed in any one of claims 5 to 32, comprising control means for controlling operation of said data receiving means, a generator for generating timing  
25 signals for operation of said control means, and wherein said controller is operatively coupled to said generator to control said generator.

34. An apparatus as claimed in claim 33, wherein said control means comprises a processor.

35. An apparatus as claimed in claim 33 or 34, wherein said generator comprises a clock signal generator.

36. An apparatus as claimed in any one of claims 33 to 35, wherein said generator is adapted to switch from an  
5 inactive state to an active state in response to said controller determining to enable recording of the data based on the sensed acceleration.

37. An apparatus as claimed in claim 36, wherein said generator is adapted to switch from an inactive state to an  
10 active state in response to a predetermined control signal from said controller.

38. An apparatus as claimed in claim 37, wherein said control signal provides electrical power for driving said generator.

15 39. An apparatus as claimed in any one of claims 33 to 38, wherein said control means is adapted to control said generator.

40. An apparatus as claimed in claim 39, wherein said control means is adapted for switching said generator from  
20 an active state to an inactive state.

41. An apparatus as claimed in claim 40, wherein said control means is adapted to switch said generator from an active state to an inactive state after said generator has been in the active state for a predetermined period of time.

25 42. An apparatus as claimed in any one of claims 33 to 41, comprising means for controlling said generator to change from an active state to an inactive state.

43. An apparatus as claimed in claim 42, wherein said means is adapted to change said generator from an active state to an inactive state after a predetermined period of time.

5 44. An apparatus as claimed in any one of claims 5 to 32, comprising control means for controlling operation of said data receiving means, a generator for generating timing signals for operation of said control means and wherein said controller is adapted to control receipt by said control  
10 means of said timing signals.

45. An apparatus as claimed in claim 44, further comprising second means for controlling receipt by said control means of timing signals from said generator.

46. An apparatus as claimed in any preceding claim,  
15 adapted to be secured to a person's head.

47. An apparatus as claimed in claim 46, adapted to be carried on a helmet to be secured to a person's head.

48. An apparatus as claimed in claim 47, further comprising mounting means for mounting the apparatus to the  
20 helmet.

49. An apparatus as claimed in claim 48, wherein said mounting means is adapted to releasably fasten the apparatus to the helmet.

50. An apparatus as claimed in any one of claims 47 to  
25 49, wherein said helmet comprises a military or combat helmet.

51. An apparatus as claimed in any preceding claim, further comprising an electrical power source for providing electrical power to the apparatus.

52. An apparatus as claimed in claim 51, wherein the  
5 electrical power source comprises one or more battery cells.

53. An apparatus as claimed in claim 52, wherein the at least one battery cell is non-rechargeable.

54. An apparatus as claimed in claim 52 or 53, wherein one or more components are mounted on a common substrate and  
10 one or more components are subsequently embedded in a pourable substance.

55. An apparatus as claimed in claim 54, further comprising a protective cover or cap for covering said board or substrate.

15 56. An apparatus for recording data indicative of acceleration of a part of a person's body or other object, comprising first memory means for receiving acceleration data from an acceleration sensor, second memory means  
operatively coupled to the first memory means for receiving  
20 data from the first memory means, and a data transfer controller for controlling the transfer of data from the first memory means to the second memory means based on the acceleration data.

57. An apparatus as claimed in claim 58, wherein the  
25 first memory means requires electrical power to hold data therein.

58. An apparatus as claimed in claim 56 or 57, wherein the second memory means is capable of holding data therein

in the absence of electrical power or with less power than required by said first memory means.

59. An apparatus as claimed in any one of claims 56 to 58, wherein said controller is adapted to enable the  
5 transfer of data from said first memory means to said second memory means in response to and/or only in the event of said acceleration data meeting a predetermined criteria.

60. An apparatus as claimed in claim 59, wherein said predetermined criteria is one of (a) a sensed value of  
10 acceleration reaches a predetermined value and (b) a sensed value of acceleration exceeds a predetermined value.

61. An apparatus as claimed in claim 59 or 60, wherein said predetermined value is at or above a value which is sufficient to cause injury or is likely to cause injury to  
15 the part of the person.

62. An apparatus as claimed in any one of claims 56 to 61, wherein the body part is a person's head.

63. An apparatus as claimed in any one of claims 56 to 62, wherein at least one of said first and second memory  
20 means is an internal memory of a processor.

64. An apparatus as claimed in any one of claims 56 to 63, further comprising a third memory means operatively coupled to said second memory means for receiving data therefrom.

25 65. An apparatus as claimed in claim 64, further comprising a memory controller for controlling the transfer of data from said second memory to said third memory.

66. An apparatus as claimed in claim 65, wherein said memory controller is conditioned to transfer acceleration data from said second memory means to said third memory means only if said second memory means contains acceleration  
5 data from a plurality of separate events.

67. An apparatus as claimed in claim 65 or 66, wherein said memory controller is adapted to transfer acceleration data relating to a plurality of different events from said second memory means to said third memory means in a single  
10 or the same write operation.

68. An apparatus as claimed in claim 67, wherein said memory controller is adapted to transfer acceleration data relating to three or more events in a single or the same operation.

15 69. An apparatus as claimed in any one of claims 64 to 68, wherein said third memory means is adapted to hold data in the absence of electrical power or with less electrical power than required by at least one of said first and second memory means.

20 70. An apparatus as claimed in any one of claims 56 to 69, further comprising monitoring means for monitoring the time of an acceleration event and means for recording the time of the event in a manner in which the time of the event is associated with acceleration data of the event.

25 71. An apparatus as claimed in any one of claims 56 to 70, further comprising a temperature sensor for sensing the temperature of one or more components of the apparatus.

72. An apparatus as claimed in claim 71, further comprising means for recording the temperature at the time  
30 of a recorded acceleration event in such a manner that the

temperature is associated with the acceleration data of the event.

73. An apparatus as claimed in any one of claims 56 to 72, further comprising sensing means for sensing  
5 acceleration and providing a signal indicative of the sensed acceleration to the first memory means.

74. An apparatus as claimed in claim 73, wherein said sensing means comprises a plurality of sensors, each capable of measuring acceleration in a single direction, and  
10 configured to measure acceleration in a direction which is mutually perpendicular to the direction of one or more other of said acceleration sensors.

75. An apparatus as claimed in any one of claims 71 to 74, wherein said temperature sensor and said first and  
15 second memory means are mounted on a common substrate.

76. An apparatus as claimed in any one of claims 56 to 75, wherein each of said first and second memory means and said controller are mounted on a common substrate.

77. An apparatus as claimed in any one of claims 56 to  
20 76, wherein said first and second memory means and said controller are contained in a unit adapted to be part of a helmet assembly.

78. An apparatus as claimed in claim 77, further comprising structure for enabling the unit to be mounted to  
25 a helmet.

79. An apparatus as claimed in claim 78, wherein said structure includes fastening means for releasably fastening the unit to the helmet.

80. An apparatus as claimed in any one of claims 56 to 79, adapted to be mounted on a military or combat helmet.

81. An apparatus as claimed in any one of claims 1 to 55, 73 or 74, wherein said sensing means is adapted to sense  
5 accelerations having values resulting from a blast or explosive force.

82. A method of calibrating a data recording unit for measuring head acceleration, comprising the steps of:

- 10 (a) providing a data recording unit mounted to a head protector;
- (b) mounting the head protector on a support;
- (c) subjecting the head protector and support to a force or pressure;
- (d) measuring acceleration of the head protector resulting  
15 from the force or pressure;
- (e) measuring acceleration of the support resulting from the force or pressure; and
- (f) determining a relationship between the measured acceleration of the head protector and of the support.

20 83. A method as claimed in claim 82, comprising subjecting the head protector and support or another head protector and/or support to a plurality of different forces or pressures and repeating at least steps (d) and (e) for each different force or pressure.

25 84. A method as claimed in claim 83, wherein each force or pressure is applied in substantially the same direction relative to the head protector and support.

85. A method as claimed in any one of claims 82 to 84, further comprising subjecting the head protector and support and/or another head protector and/or support to a plurality of successive forces or pressures each applied to the head protector and support in a different direction, and  
5 repeating at least steps (d) and (e) for each different direction.

86. A method as claimed in claim 85, wherein a plurality of forces or pressures in different directions  
10 have substantially the same strength.

87. A method as claimed in any one of claims 82 to 86, further comprising using the relationship to determine head acceleration from data recorded by a data recording unit mounted to a head protector.

15 88. A method as claimed in claim 87, wherein the data recording unit comprises a data recording unit other than the data recording unit used to determine said relationship, for example, a data recording unit used in actual service.

89. A method of determining the value of a parameter  
20 indicative of acceleration of a person's head or other object, comprising the steps of: acquiring data measured by an acceleration sensor mounted to a head protector and using a calibration method to determine from the data the value of said parameter.

25 90. A method as claimed in claim 89, wherein the calibration method is derived from data describing a relationship between head acceleration and head protector acceleration.

91. A method as claimed in claim 89 or 90, further  
30 comprising determining the direction of acceleration from

the acquired data and selecting the calibration method based on the direction.

92. The use of an apparatus as claimed in any one of claims 1 to 81, for monitoring acceleration of a part of a body of a military or other service personnel.

93. A method of monitoring acceleration of a part of a body of military or service personnel comprising mounting a monitor for monitoring acceleration to the body part to be monitored.

94. A method as claimed in claim 93, further comprising the step of, by means of a controller, controlling activation of data recording means from an inactive state to an active state based on the monitored acceleration.

95. A method as claimed in claim 93 or 94, further comprising, by means of a controller, determining whether or not to transfer acceleration data resulting from said monitoring from a first memory means to a second memory means based on the monitored acceleration.

96. A method as claimed in any one of claims 93 to 95, further comprising any one or more features claimed or disclosed herein.

97. A method as claimed in any one of claims 93 to 96, wherein said monitor is capable to measuring acceleration of the body part resulting from an explosion.

98. An apparatus comprising substantially as hereinbefore described with reference to and illustrated by any one of the drawings.

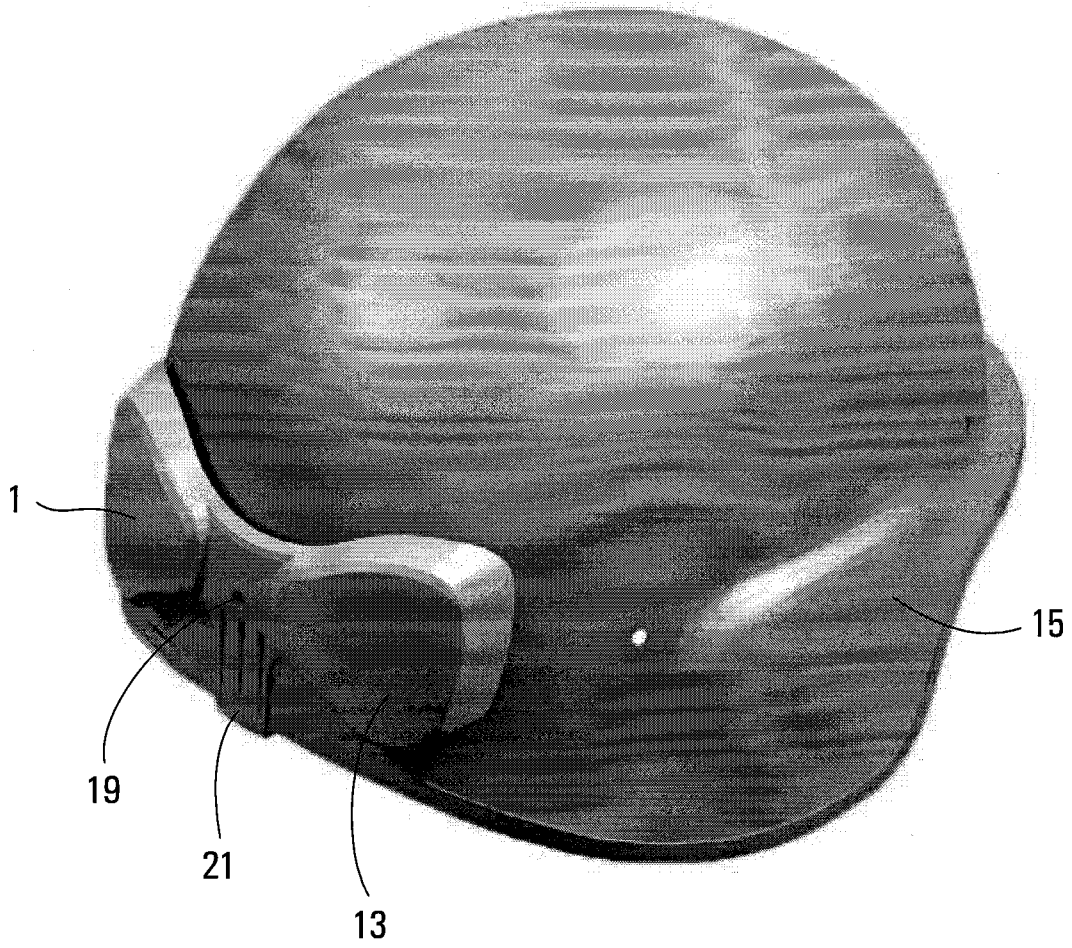

**FIG. 1**

2/11

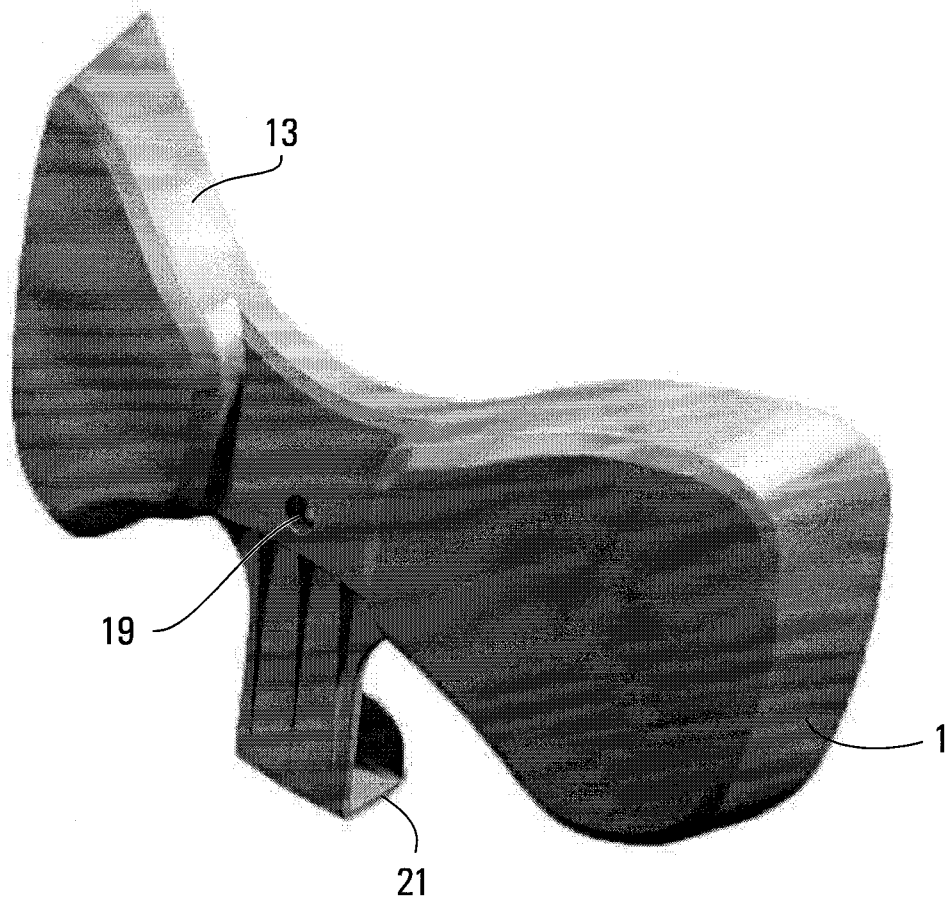

**FIG. 2**

3/11

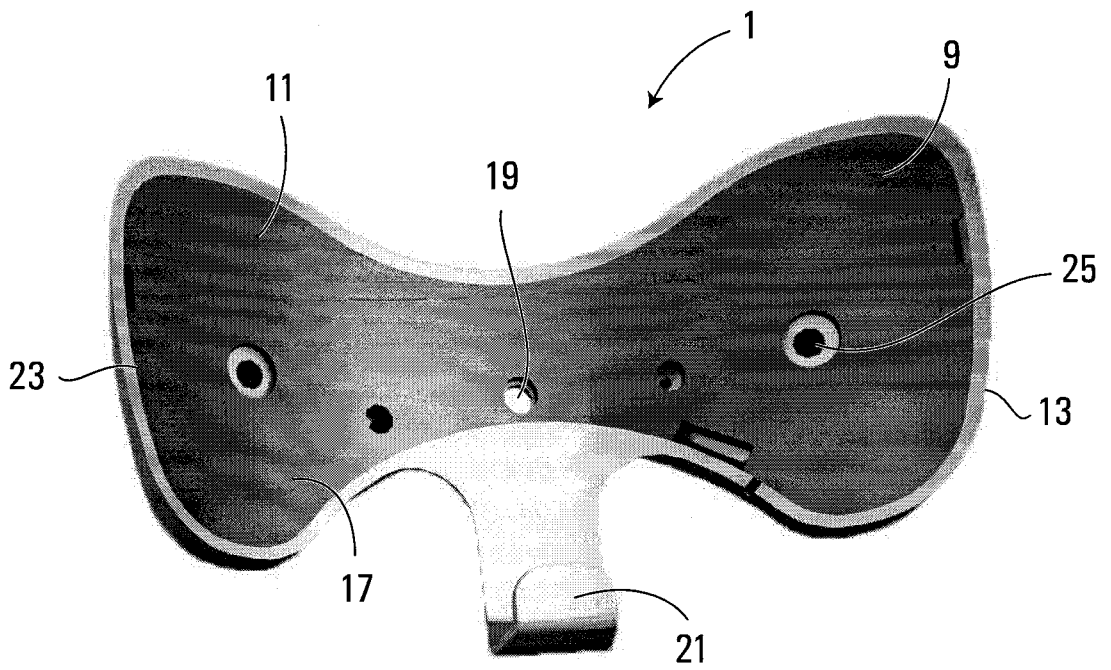

**FIG. 3**

4/11

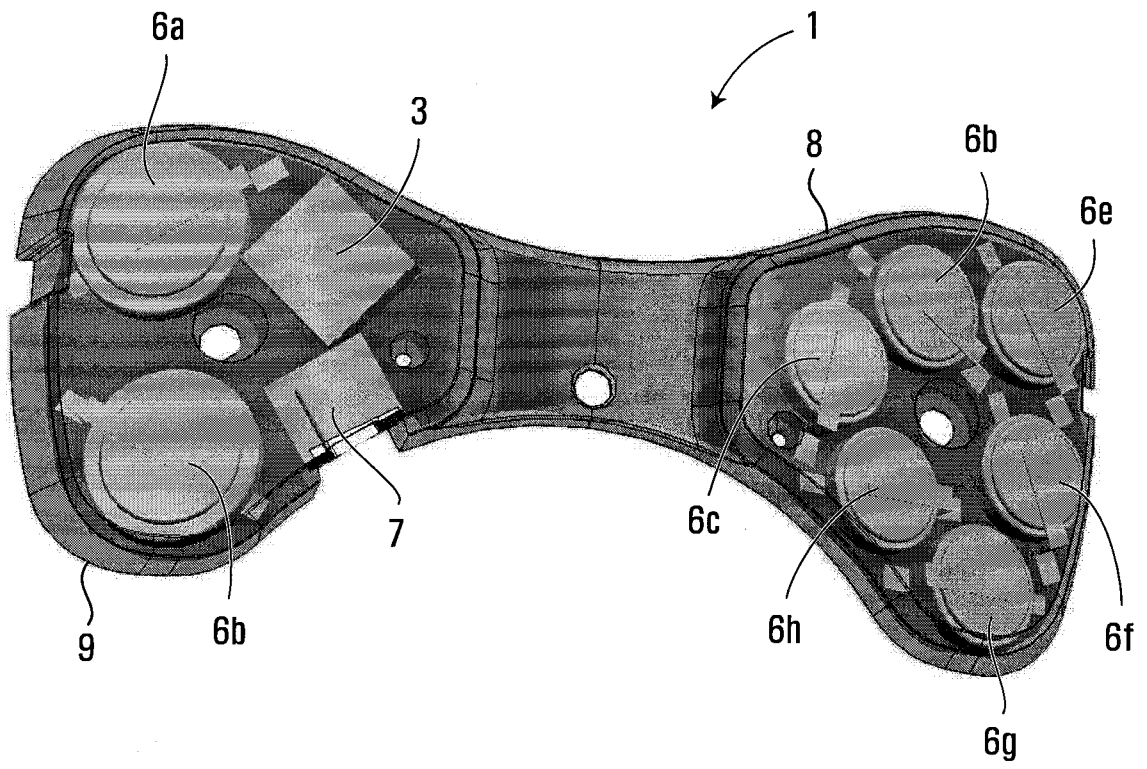
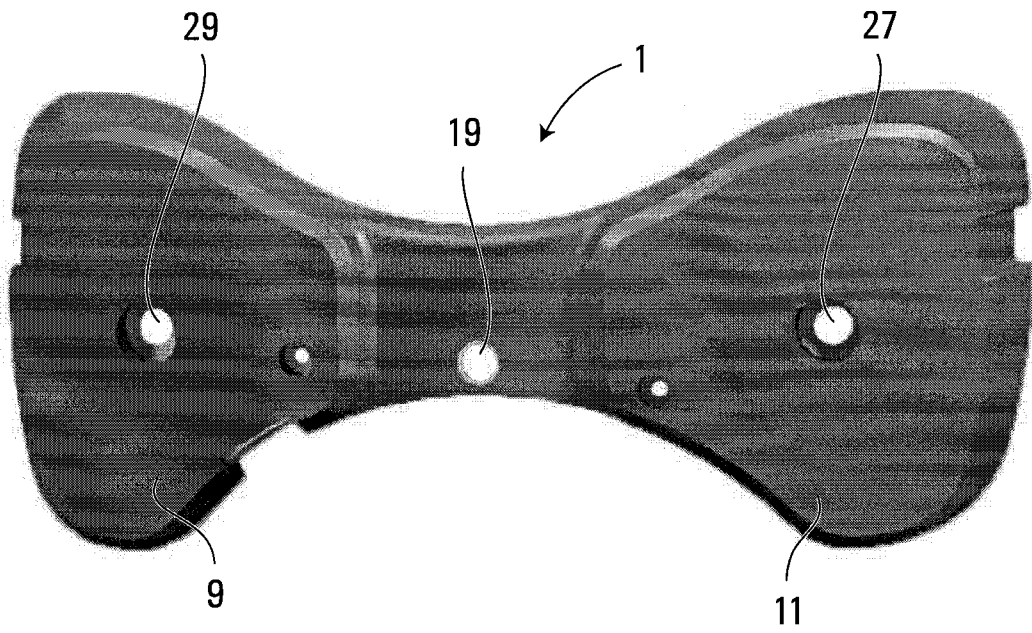

FIG. 4

5/11



**FIG. 5**

6/11

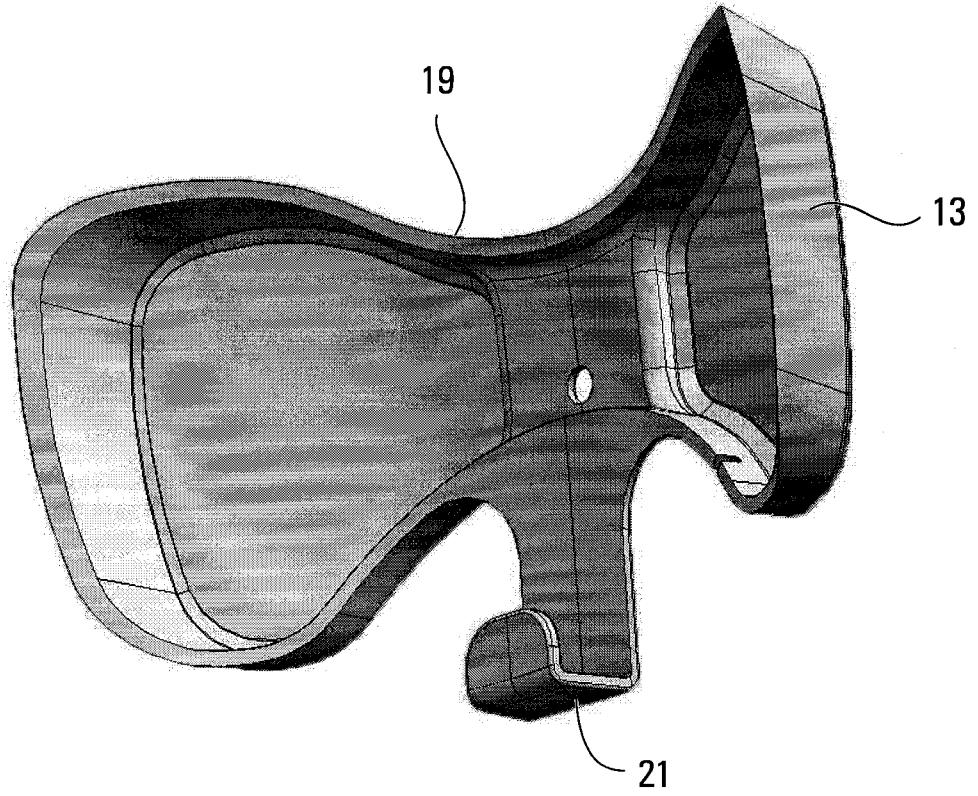

**FIG. 6**

7/11

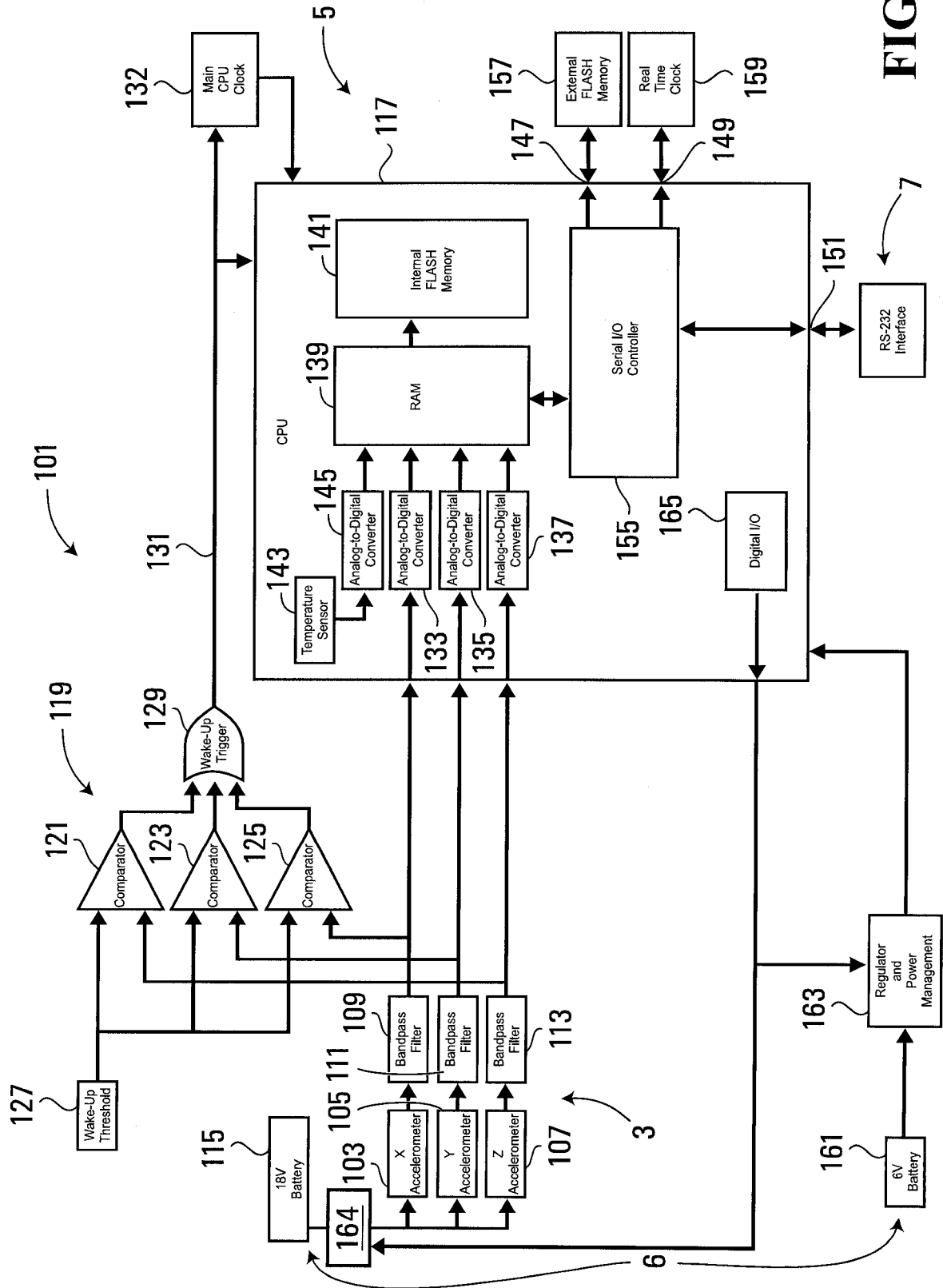
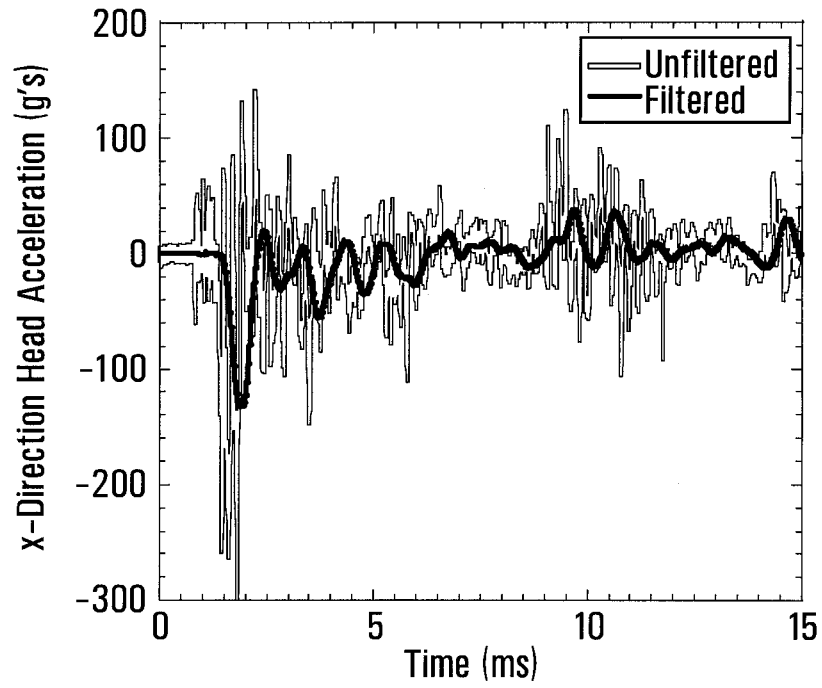
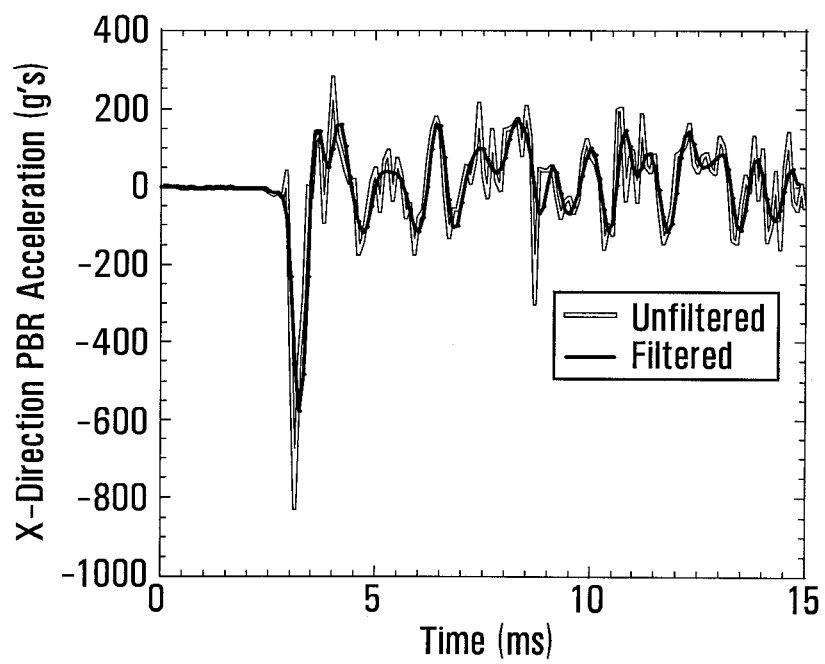

FIG. 7

8/11

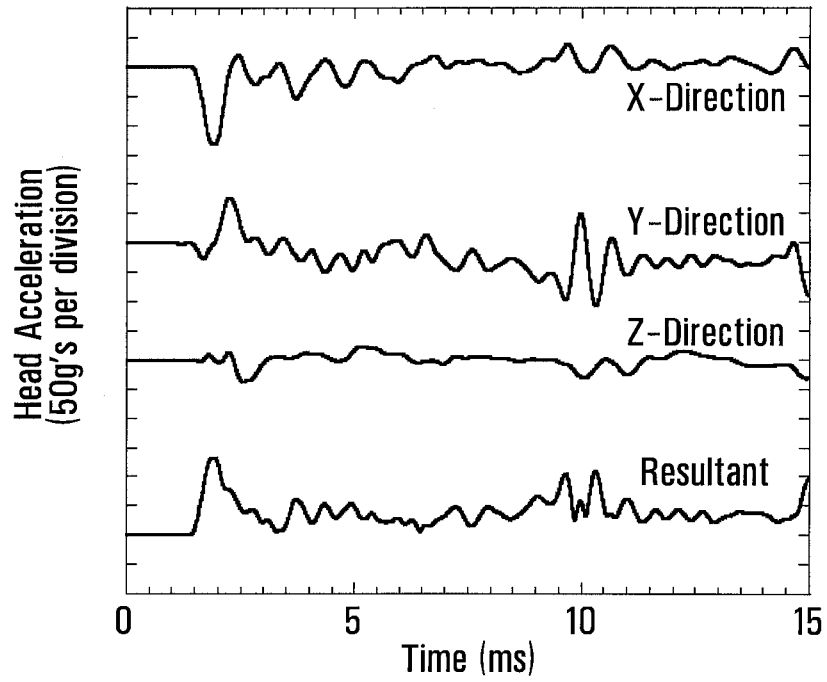

**FIG. 8**

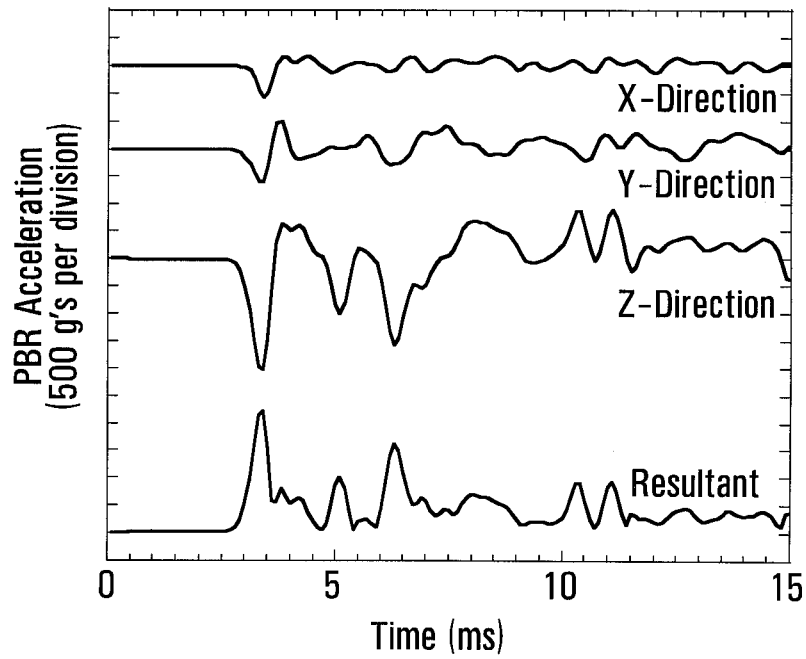

**FIG. 9**

9/11

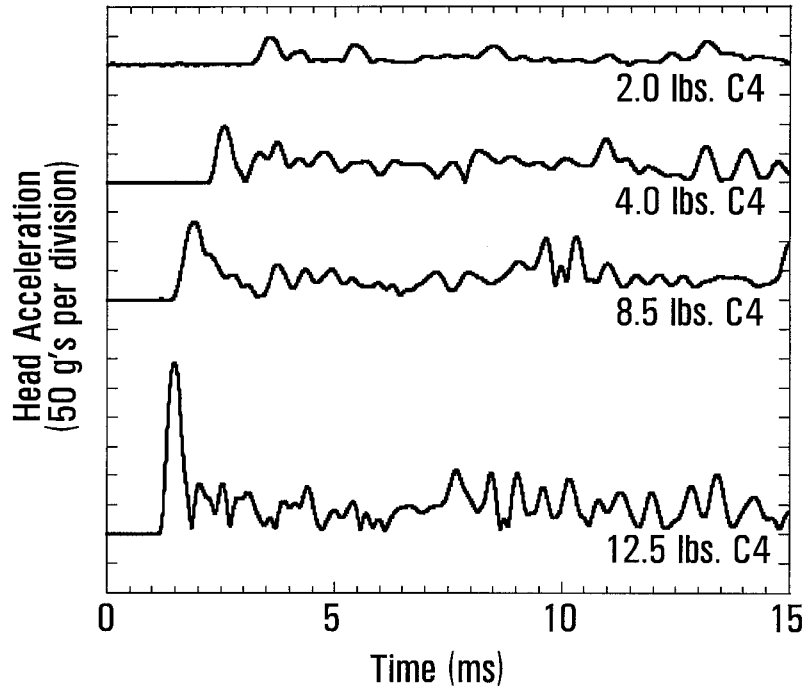

**FIG. 10**

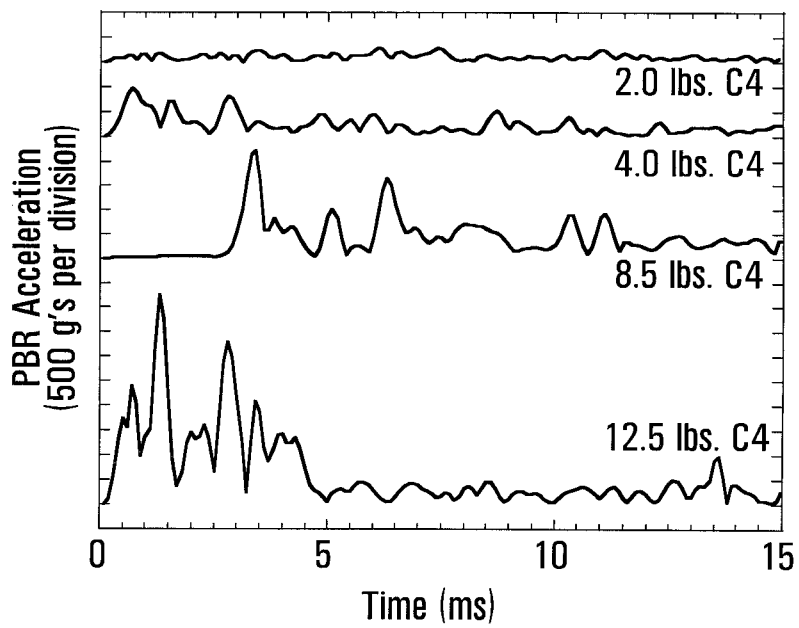

**FIG. 11**

10/11

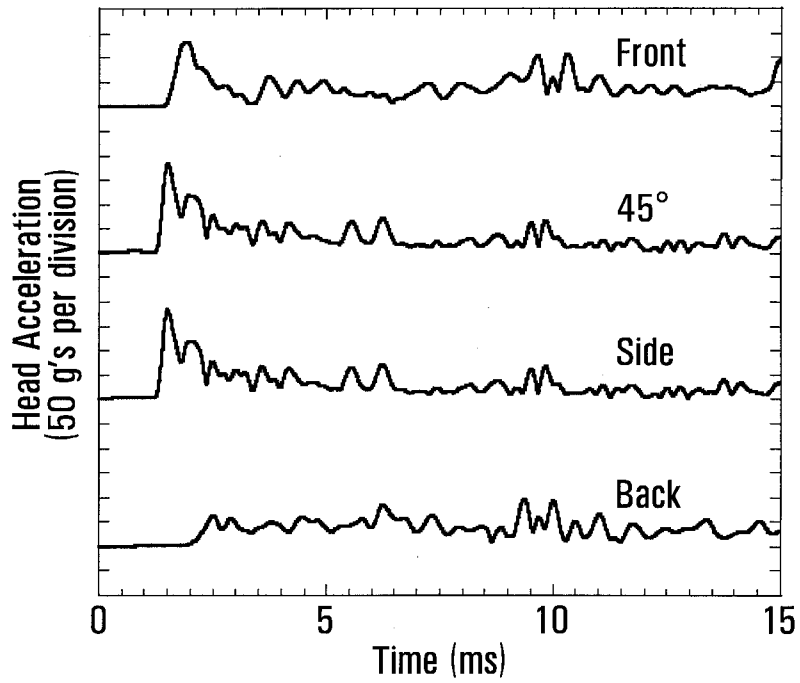

**FIG. 12**

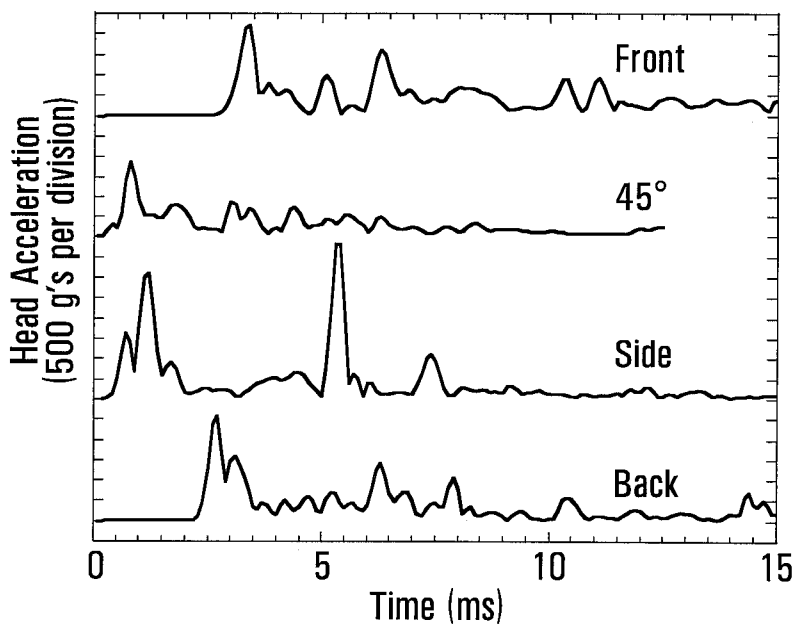

**FIG. 13**

11/11



**FIG. 14**



**FIG. 15**

## INTERNATIONAL SEARCH REPORT

International application No.  
PCT/CA2008/002124

A. CLASSIFICATION OF SUBJECT MATTER IPC: <b>A61B 5/11</b> (2006.01) , <b>G01P 1/12</b> (2006.01) , <b>G01P 21/00</b> (2006.01) , <b>A42B 3/04</b> (2006.01) , <b>F41H 1/04</b> (2006.01) , <b>G01L 5/14</b> (2006.01) (more IPCs on the last page) According to International Patent Classification (IPC) or to both national classification and IPC		
B. FIELDS SEARCHED		
Minimum documentation searched (classification system followed by classification symbols) IPC(2006.01): A61B, G01P, A63B, G01M		
Documentation searched other than minimum documentation to the extent that such documents are included in the fields searched		
Electronic database(s) consulted during the international search (name of database(s) and, where practicable, search terms used) Questel-Orbit (EP, FamPat, FRPATENT, JAPIO, WOPATENT, US), Canadian Patent Database, USPTO WEST (Keywords: measure/sens/detect acceleration; head/helmet/body part; record data; threshold; exceed value)		
C. DOCUMENTS CONSIDERED TO BE RELEVANT		
Category*	Citation of document, with indication, where appropriate, of the relevant passages	Relevant to claim No.
X	US 2005/0177929 A1 (GREENWALD R. ET AL.) 18 August 2005 (18-08-2005) * Paragraphs [0022], [0026], [0029], [0055], [0060], [0061], Figures 4 and 7 *	1, 10-12, 46-48
Y		2-9, 13-45, 49-55
Y	US 6,122,959 (HOSHAL G. ET AL.) 26 September 2000 (26-09-2000) * Column 2, lines 1-14; column 3, lines 50-55; column 6, lines 9-14 * * Column 6, lines 61-65 *	2-9, 14-45, 51-55
<input type="checkbox"/> Further documents are listed in the continuation of Box C. <input checked="" type="checkbox"/> See patent family annex.		
* Special categories of cited documents :	"T"	later document published after the international filing date or priority date and not in conflict with the application but cited to understand the principle or theory underlying the invention
"A" document defining the general state of the art which is not considered to be of particular relevance	"X"	document of particular relevance; the claimed invention cannot be considered novel or cannot be considered to involve an inventive step when the document is taken alone
"E" earlier application or patent but published on or after the international filing date	"Y"	document of particular relevance; the claimed invention cannot be considered to involve an inventive step when the document is combined with one or more other such documents, such combination being obvious to a person skilled in the art
"L" document which may throw doubts on priority claim(s) or which is cited to establish the publication date of another citation or other special reason (as specified)	"&"	document member of the same patent family
"O" document referring to an oral disclosure, use, exhibition or other means		
"P" document published prior to the international filing date but later than the priority date claimed		
Date of the actual completion of the international search 19 January 2009 (19-01-2009)	Date of mailing of the international search report 30 March 2009 (30-03-2009)	
Name and mailing address of the ISA/CA Canadian Intellectual Property Office Place du Portage I, C114 - 1st Floor, Box PCT 50 Victoria Street Gatineau, Quebec K1A 0C9 Facsimile No.: 001-819-953-2476	Authorized officer <b>Patrick Abou-Antoun 819- 994-7470</b>	

**Box No. II Observations where certain claims were found unsearchable (Continuation of item 2 of the first sheet)**

This international search report has not been established in respect of certain claims under Article 17(2)(a) for the following reasons :

1.  Claim Nos. :  
because they relate to subject matter not required to be searched by this Authority, namely :
  
2.  Claim Nos. : 98  
because they relate to parts of the international application that do not comply with the prescribed requirements to such an extent that no meaningful international search can be carried out, specifically :  
  
Claim 98 relies entirely on references to the description and drawings, and thus does not comply with Rule 6.2(a) of the PCT.
  
3.  Claim Nos. :  
because they are dependent claims and are not drafted in accordance with the second and third sentences of Rule 6.4(a).

**Box No. III Observations where unity of invention is lacking (Continuation of item 3 of first sheet)**

This International Searching Authority found multiple inventions in this international application, as follows :

See extra sheet

1.  As all required additional search fees were timely paid by the applicant, this international search report covers all searchable claims.
2.  As all searchable claims could be searched without effort justifying additional fees, this Authority did not invite payment of additional fees.
3.  As only some of the required additional search fees were timely paid by the applicant, this international search report covers only those claims for which fees were paid, specifically claim Nos. :
4.  No required additional search fees were timely paid by the applicant. Consequently, this international search report is restricted to the invention first mentioned in the claims; it is covered by claim Nos. : 1-55

- Remark on Protest**
- The additional search fees were accompanied by the applicant's protest and, where applicable, the payment of a protest fee.
- The additional search fees were accompanied by the applicant's protest but the applicable protest fee was not paid within the time limit specified in the invitation.
- No protest accompanied the payment of additional search fees.

**INTERNATIONAL SEARCH REPORT**  
Information on patent family members

International application No.  
PCT/CA2008/002124

Patent Document Cited in Search Report	Publication Date	Patent Family Member(s)	Publication Date
US 2005177929A1	18-08-2005	CA 2580318A1	06-04-2006
		CA 2590034A1	13-07-2006
		CA 2593088A1	13-07-2006
		MX 2007003015A	09-11-2007
		MX 2007008303A	12-12-2007
		MX 2007008304A	18-01-2008
		US 6826509B2	30-11-2004
		US 2002060633A1	23-05-2002
		US 2005177335A1	11-08-2005
		US 2006074338A1	06-04-2006
		US 2006189852A1	24-08-2006
		WO 2006036567A1	06-04-2006
		WO 2006074253A1	13-07-2006
		WO 2006074253A9	21-09-2006
		WO 2006074411A2	13-07-2006
		WO 2006074411A3	07-12-2006
US 6122959A	26-09-2000	None	

Continuation of: Box No. III

This International Searching Authority found multiple inventions in this international application, as follows:

**Group I**

Claims 1-55 are directed to an apparatus for measuring acceleration of a person's head or other object, comprising sensing means for sensing acceleration, and a controller for enabling recording of data based on the sensed acceleration.

**Group II**

Claims 56-81 are directed to an apparatus for recording data indicative of acceleration of a part of a person's body or other object, comprising first memory means for receiving acceleration data from a sensor, second memory means operatively coupled to the first memory means, and a data transfer controller for controlling the transfer of data between the two memory means based on the acceleration data.

**Group III**

Claims 82-88 are directed to a method of calibrating a data recording unit for measuring head acceleration comprising the steps of: providing a data recording unit mounted to a head protector; mounting the head protector on a support; subjecting the head protector and support to a force or pressure; measuring acceleration of the head protector resulting from the force or pressure; measuring acceleration of the support resulting from the force or pressure; and determining a relationship between the measured acceleration of the head protector and of the support.

**Group IV**

Claims 89-92 are directed to a method of determining the value of a parameter indicative of acceleration of a person's head or other object, comprising the steps of: acquiring data measured by an acceleration sensor mounted to a head protector and using a calibration method to determine from the data the value of said parameter.

**Group V**

Claims 93-97 are directed to a method of monitoring acceleration of a part of a body of military or service personnel comprising mounting a monitor for monitoring acceleration to the body part to be monitored.

Since the only characteristic feature which is common to the five groups of claims (measuring/recording acceleration data) is taught in the prior art, the claims are without a common general inventive concept. As such, there exists a lack of unity a posteriori between all five groups of claims.

专利名称(译)	用于测量损伤分析数据的装置和方法		
公开(公告)号	<a href="#">EP2229100A4</a>	公开(公告)日	2013-05-15
申请号	EP2008856837	申请日	2008-12-08
[标]申请(专利权)人(译)	ALLEN VANGUARD TECH		
申请(专利权)人(译)	艾伦 - 先锋科技股份有限公司.		
当前申请(专利权)人(译)	艾伦 - 先锋科技股份有限公司.		
[标]发明人	HUBLER GRAHAM BYERS JEFFREY HOUSTON BRIAN CORSARO ROBERT FRANK PHIL KOST JASON OPACHKO KENNY BERDOZ ALAIN HERDIC PETER CHIN LOCK SUI LEVINE JEFFREY DIONNE JEAN PHILIPPE WONG DOUG CROSSMAN DANIEL		
发明人	HUBLER, GRAHAM BYERS, JEFFREY HOUSTON, BRIAN CORSARO, ROBERT FRANK, PHIL KOST, JASON OPACHKO, KENNY BERDOZ, ALAIN HERDIC, PETER CHIN, LOCK-SUI LEVINE, JEFFREY DIONNE, JEAN-PHILIPPE WONG, DOUG CROSSMAN, DANIEL		
IPC分类号	A61B5/11 G01P1/12 G01P21/00 A42B3/04 F41H1/04 G01L5/14 A61B5/00		
CPC分类号	F41H1/04 A42B3/046 A61B5/11 A61B5/6803 A61B5/6814 A61B5/7275 A61B2560/0209 A61B2562/0219 G01L5/14 G01P1/127		
优先权	60/996855 2007-12-07 US		
其他公开文献	EP2229100A1		
外部链接	<a href="#">Espacenet</a>		

#### 摘要(译)

所提供的用于测量人的头部或其他物体的加速度的设备。该设备包括用于感测加速度的传感器和用于控制由于爆炸力而感测到的加速度产生的数据的记录的控制器。控制器适于基于感测到的加速度来确定是否允许记录数据。提供数据接收器以从感测装置接收

感测到的加速度数据，并且需要电力以使得能够由此接收数据。控制器控制到接收器的电功率，使得如果感测到的加速度达到或超过预定值，则启用到数据接收器的电功率。所记录的加速度数据可以用于伤害分析。