

(19) World Intellectual Property Organization
International Bureau



(43) International Publication Date
8 December 2005 (08.12.2005)

PCT

(10) International Publication Number
WO 2005/115231 A1

(51) International Patent Classification⁷: **A61B 5/04**

[US/US]; 5 Cyndy Lane, Millbury, MA 01527 (US). **HE, Ding, Sheng** [US/US]; 377 Westford Road, Tyngsboro, MA 01879 (US).

(21) International Application Number:
PCT/US2005/017080

(74) Agent: **WALSH, Edmund, J.**; Wolf, Greenfield & Sacks, P.C, 600 Atlantic Avenue, Boston, MA 02210 (US).

(22) International Filing Date: 17 May 2005 (17.05.2005)

(25) Filing Language: English

(81) Designated States (unless otherwise indicated, for every kind of national protection available): AE, AG, AL, AM, AT, AU, AZ, BA, BB, BG, BR, BW, BY, BZ, CA, CH, CN, CO, CR, CU, CZ, DE, DK, DM, DZ, EC, EE, EG, ES, FI, GB, GD, GE, GH, GM, HR, HU, ID, IL, IN, IS, JP, KE, KG, KM, KP, KR, KZ, LC, LK, LR, LS, LT, LU, LV, MA, MD, MG, MK, MN, MW, MX, MZ, NA, NG, NI, NO, NZ, OM, PG, PH, PL, PT, RO, RU, SC, SD, SE, SG, SK, SL, SM, SY, TJ, TM, TN, TR, TT, TZ, UA, UG, US, UZ, VC, VN, YU, ZA, ZM, ZW.

(26) Publication Language: English

(30) Priority Data:
60/571,781 17 May 2004 (17.05.2004) US
60/571,843 17 May 2004 (17.05.2004) US
60/571,821 17 May 2004 (17.05.2004) US

(71) Applicant (for US only): **C.R. BARD, INC.** [US/US]; 730 Central Avenue, Murray Hill, NJ 07974 (US).

(72) Inventors; and

(84) Designated States (unless otherwise indicated, for every kind of regional protection available): ARIPO (BW, GH, GM, KE, LS, MW, MZ, NA, SD, SL, SZ, TZ, UG, ZM,

(75) Inventors/Applicants (for US only): **MacADAM, David**

[Continued on next page]

(54) Title: ELECTROPHYSIOLOGY SYSTEM FOR MAPPING AND ABLATING ARRHYTHMIAS

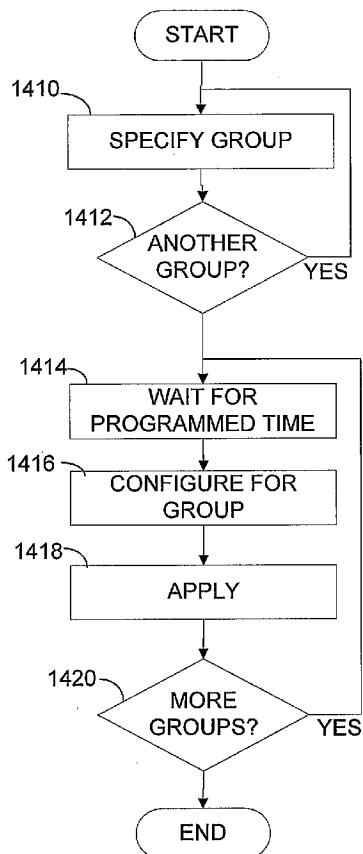

(57) Abstract: An electrophysiology system for mapping and/or ablating tissue includes a catheter having a plurality of electrically active sites. The system includes a controller providing a user interface through which the plurality of sites may be controlled. The sites may be accessed individually or in groups. In addition, the order and timing of the accessing of specific electrically active sites may be controlled in a manual or automated fashion.

WO 2005/115231 A1



ZW), Eurasian (AM, AZ, BY, KG, KZ, MD, RU, TJ, TM), European (AT, BE, BG, CH, CY, CZ, DE, DK, EE, ES, FI, FR, GB, GR, HU, IE, IS, IT, LT, LU, MC, NL, PL, PT, RO, SE, SI, SK, TR), OAPI (BF, BJ, CF, CG, CI, CM, GA, GN, GQ, GW, ML, MR, NE, SN, TD, TG).

Published:

— with international search report

— before the expiration of the time limit for amending the claims and to be republished in the event of receipt of amendments

For two-letter codes and other abbreviations, refer to the "Guidance Notes on Codes and Abbreviations" appearing at the beginning of each regular issue of the PCT Gazette.

- 1 -

ELECTROPHYSIOLOGY SYSTEM FOR MAPPING AND ABLATING ARRHYTHMIAS

RELATED APPLICATIONS

5 This application claims priority under 35 U.S.C. § 119(e) to U.S. Provisional
Application Serial No. 60/571,781, entitled "MAPPING AND ABLATION METHOD
AND APPARATUS FOR THE TREATMENT OF IDIOPATHIC VENTRICULAR
TACHYCARDIA ORIGINATING FROM RVOT OR LVOT," filed on May 17, 2004,
which is herein incorporated by reference in its entirety, and U.S. Provisional
10 Application Serial No. 60/571,843, entitled "MAPPING AND ABLATION METHOD
AND APPARATUS FOR THE TREATMENT OF IDIOPATHIC VENTRICULAR
TACHYCARDIA," filed on May 17, 2004, which is herein incorporated by reference in
its entirety. This application claims priority under 35 U.S.C. § 119(e) to U.S. Provisional
Application Serial No. 60/571,821, entitled "METHOD AND APPARATUS FOR
15 MAPPING AND/OR ABLATION OF CARDIAC TISSUE," filed on May 17, 2004,
which is herein incorporated by reference in its entirety.

BACKGROUND OF INVENTION

1. Field of Invention

20 The invention relates generally to medical devices for performing mapping and
ablation procedures. More particularly, the invention relates to a system for mapping
and/or ablating cardiac walls.

2. Discussion of Related Art

25 The human heart is a very complex organ, which relies on both muscle
contraction and electrical impulses to function properly. The electrical impulses travel
through the heart walls, first through the atria and then the ventricles, causing the
corresponding muscle tissue in the atria and ventricles to contract. Thus, the atria
contract first, followed by the ventricles. This order is essential for proper functioning of
30 the heart.

 Over time, the electrical impulses traveling through the heart can begin to travel
in improper directions, thereby causing the heart chambers to contract at improper times.

- 2 -

Such a condition is generally termed a cardiac arrhythmia, and can take many different forms. When the chambers contract at improper times, the amount of blood pumped by the heart decreases, which can result in premature death of the person.

Techniques have been developed which are used to locate cardiac regions
5 responsible for the cardiac arrhythmia, and also to disable the short-circuit function of these areas. According to these techniques, electrical energy is applied to a portion of the heart tissue to ablate that tissue and produce scars which interrupt the reentrant conduction pathways or terminate the focal initiation. The regions to be ablated are usually first determined by endocardial mapping techniques. Mapping may be active or
10 passive. Active mapping, sometimes called "pace mapping," typically involves percutaneously introducing a catheter having one or more electrodes into the patient, passing the catheter through a blood vessel (e.g. the femoral vein or artery) and into an endocardial site (e.g., the atrium or ventricle of the heart), and deliberately inducing an arrhythmia so that a continuous, simultaneous recording can be made with a
15 multichannel recorder at each of several different endocardial positions. Passive mapping techniques typically involve sensing electrical signals from the electrodes on the catheter.

When an arrhythmogenic focus or inappropriate circuit is located, as indicated in the electrocardiogram recording, it is marked by various imaging or localization means
20 so that cardiac arrhythmias emanating from that region can be blocked by ablating tissue. An ablation catheter with one or more electrodes can then transmit electrical energy to the tissue adjacent the electrode to create a lesion in the tissue. One or more suitably positioned lesions will typically create a region of necrotic tissue which serves to disable the propagation of the errant impulse caused by the arrhythmogenic focus. Ablation is
25 carried out by applying energy to the catheter electrodes. The ablation energy can be, for example, RF, DC, ultrasound, microwave, or laser radiation.

Atrial fibrillation together with atrial flutter are the most common sustained arrhythmias found in clinical practice. Current understanding is that atrial fibrillation is frequently initiated by a focal trigger from the orifice of or within one of the pulmonary
30 veins. Though mapping and ablation of these triggers appears to be curative in patients with paroxysmal atrial fibrillation, there are a number of limitations to ablating focal triggers via mapping and ablating the earliest site of activation with a "point"

- 3 -

radiofrequency lesion. One way to circumvent these limitations is to determine precisely the point of earliest activation. Once the point of earliest activation is identified, a lesion can be generated to electrically isolate the trigger with a lesion; firing from within those veins would then be eliminated or unable to reach the body of the atrium, and thus could
5 not trigger atrial fibrillation.

Another method to treat focal arrhythmias is to create a continuous, annular lesion around the ostia (i.e., the openings) of either the veins or the arteries leading to or from the atria, thus "corralling" the signals emanating from any points distal to the annular lesion. Conventional techniques include applying multiple point sources around
10 the ostia in an effort to create such a continuous lesion. Such a technique is relatively involved, and requires significant skill and attention from the clinician performing the procedures.

Another source of arrhythmias may be from reentrant circuits in the myocardium itself. Such circuits may not necessarily be associated with vessel ostia, but may be
15 interrupted by means of ablating tissue either within the circuit or circumscribing the region of the circuit. It should be noted that a complete "fence" around a circuit or tissue region is not always required in order to block the propagation of the arrhythmia; in many cases simply increasing the propagation path length for a signal may be sufficient. Conventional means for establishing such lesion "fences" include a multiplicity of point-
20 by-point lesions, dragging a single electrode across tissue while delivering energy, or creating an enormous lesion intended to inactivate a substantive volume of myocardial tissue.

U.S. Patent No. 6,315,778 B1, entitled "Apparatus For Creating A Continuous Annular Lesion," which is herein incorporated by reference, discloses a medical device
25 which is capable of ablating a ring of tissue around the ostia of either veins or arteries leading to or from the atria. The medical device includes a protrusion that inserts into an ostium, thereby allowing electrodes to contact tissue near the ostium.

In some instances, it is desirable to perform mapping and/or ablation procedures on a cardiac wall (or other tissue) that is not located near an ostium. In such a scenario,
30 the lack of a protrusion may help to allow electrodes of a device contact the cardiac wall or other tissue. In other cases, mapping and/or ablation may be desired at several locations around an ostium and it would be helpful to be able to position electrodes

- 4 -

without concern for a protrusion that may hinder contact between electrodes and the cardiac wall.

Another type of arrhythmia is Ventricular tachycardia. Ventricular tachycardia (VT) usually arises in diseased myocardium. However, VT can occur in the absence of
5 structural heart disease, or at least in hearts in which current diagnostic techniques fail to identify any anatomic or functional abnormalities. These arrhythmias have been termed "idiopathic VTs". The mechanisms underlying idiopathic VT are varied and include reentry and triggered activity due to delayed after depolarizations.

Idiopathic VTs that arise from the right to left ventricular outflow tract (RVOT
10 VT and LVOT VT) have been reported. Thus RVOT VT and LVOT VT patients could be treated with RF ablation. However, the success rate of ablation therapy for treatment of VT is affected by many factors, such as the inability to induce tachycardia to permit mapping, and the presence of deep, often septal sites of origin that are resistant to RF ablation with conventional ablation catheters, usually a 4-mm ablation catheter. Treating
15 VT in the area of the outflow track with ablation therapy has been difficult.

SUMMARY OF INVENTION

Embodiments of the present invention encompass apparatus and methods for mapping electrical activity within the heart. Embodiments of the present invention also
20 encompass methods and apparatus for creating lesions in the heart tissue (ablating) to create a region of necrotic tissue which serves to disable the propagation of errant electrical impulses caused by an arrhythmia. The apparatus and methods described herein also may be used for mapping and ablating of tissue other than heart tissue.

In one aspect, the invention relates to a computer-readable medium comprising
25 computer-executable instructions for controlling an electrophysiology system of the type having a catheter with a plurality of electrically active sites. The computer-executable instructions performing acts of providing at least one display area through which a user may specify a set of the electrically active sites to be used in sensing signals from the heart; providing at least one display area through which a user may specify a set of the
30 electrically active sites to be used in sending stimulation signals to the heart; and providing at least one display area through which a user may specify a set of the electrically active sites to be used in sending an ablation signal to the heart.

- 5 -

In another aspect, the invention relates to a computer-readable medium comprising computer-executable instructions for controlling an electrophysiology system of the type having a catheter with a plurality of electrically active sites. The computer-executable instructions for performing acts of, for each of a plurality of sets of
5 electrically active sites, receiving from a user a specification of the electrically active sites in the set; and receiving from the user a specification of a specified order of the plurality of sets; and for each of the sets, successively in the specified order, controlling the electrophysiology system to access the electrically active sites of the set.

In a further aspect, the invention relates to a method of providing and selecting
10 from a menu on a display in an electrophysiology system having a catheter with a plurality of electrically active sites and a computer having a graphical user interface, the method involves: displaying on the display a graphical representation of each of the plurality of electrically active sites on the catheter; receiving at least one selection signal indicative of the user interface selection device pointing at a graphical representation of a
15 selected one of the plurality of electrically active sites; and controlling the electrophysiology system to selectively access at least one of the electrically active sites based on the at least one selection signal.

BRIEF DESCRIPTION OF DRAWINGS

20 The accompanying drawings are not intended to be drawn to scale. In the drawings, like components that are illustrated in various figures are represented by a like numeral. For purposes of clarity, not every component may be labeled in every drawing. In the drawings:

FIG. 1 illustrates an overview of an electrophysiology system in accordance with
25 one embodiment of the present invention;

FIG. 2 illustrates a braided conductive member in an undeployed state that may be used in one embodiment of the invention;

FIG. 3 illustrates a braided conductive member in a partially expanded state that may be used in one embodiment of the invention;

30 FIG. 4 illustrates a braided conductive member in an inverted state that may be used in one embodiment of the invention;

- 6 -

FIG. 5 illustrates a braided conductive member in an inverted state where a distal end of the braided conductive member does not protrude distally from the inverted braided conductive member that may be used in one embodiment of the invention;

FIG. 6 illustrates a braided conductive member including support elements that
5 may be used in one embodiment of the invention;

FIG. 7 illustrates a braided conductive member that may be used in another embodiment of the invention;

FIG. 8 illustrates an alternate embodiment of the braided conductive member that may be used in another embodiment of the invention;

FIG. 9 illustrates the use of irrigation that may be used in one embodiment of the
10 invention;

FIG. 10 illustrates the use of irrigation that may be used in another embodiment of the invention;

FIG. 10A is an enlarged cross-sectional view of a filament used in the braided
15 conductive member illustrated in FIG. 10;

FIG. 11 illustrates one embodiment of a method of using a catheter and the braided conductive member;

FIG. 12 is a sketch showing the electrophysiology system of FIG. 1 in greater detail;

FIGs. 13A and 13B are sketches of graphical user interfaces in embodiments of
20 the electrophysiology system of FIG. 12; and

FIG. 14 is a flow chart of a method of operation of the electrophysiology system of FIG. 12.

25

DETAILED DESCRIPTION

This invention is not limited in its application to the details of construction and the arrangement of components and acts set forth in the following description or illustrated in the drawings. The invention is capable of other embodiments and of being practiced or of being carried out in various ways. Also, the phraseology and terminology
30 used herein is for the purpose of description and should not be regarded as limiting. The use of "including," "comprising," or "having," "containing", "involving", and

- 7 -

variations thereof herein, is meant to encompass the items listed thereafter and equivalents thereof as well as additional items.

System Overview

Reference is now made to FIG. 1, which illustrates an overview of an
5 electrophysiology system, such as may be used for mapping and/or ablation to detect and treat cardiac arrhythmia. The system includes a catheter 10 having a shaft portion 12, a control handle 14, a connector portion 16, and a braided conductive member 28. A controller 8 is connected to connector portion 16 via cable 6. Ablation energy generator 4 may be connected to controller 8 via cable 3. A recording device 2 may be connected
10 to controller 8 via cable 1. When used in an ablation application, controller 8 is used to control ablation energy provided to catheter 10 by ablation energy generator 4. When used in a mapping application, controller 8 is used to process signals coming from catheter 10 and to provide these signals to recording device 2. Although illustrated as separate devices, recording device 2, ablation energy generator 4, and controller 8 could
15 be incorporated into a single device or two devices.

In this description, various aspects and features of exemplary embodiments of the present invention will be described. These aspects and features are discussed separately for clarity. One skilled in the art will appreciate that the features may be selectively combined in a device depending upon the particular application. Furthermore, any of the
20 various features may be incorporated in a system and associated method of use for either mapping and/or ablation procedures.

Catheter Overview

Reference is now made to FIGS. 2-5, which illustrate a catheter that may be used in the electrophysiology system of FIG. 1. Embodiments of the present invention
25 generally include a catheter and methods of its use for mapping and ablation in electrophysiology procedures.

FIG. 2 illustrates braided conductive member 28 in an unexpanded state. In this embodiment, the unexpanded state of the braided conductive member is an undeployed configuration. Braided conductive member 28 is, in one embodiment of the invention, a
30 plurality of interlaced, electrically conductive filaments 34 which are attached at a distal end 18 with a cap 24 and also at a proximal end 19 with an anchoring element 32. Of course any suitable element or method may be used to attach or anchor filaments 34.

- 8 -

FIG. 3 illustrates braided conductive member 28 in a partially expanded state. Each of FIGS. 2 and 3 show a state in which braided conductive member 28 is completely everted.

FIG. 4 illustrates braided conductive member 28 in a first deployed configuration option which may be used to locate braided conductive member 28 at an ostium. In FIG. 4, distal end 18 of braided conductive member 28 is partially inverted. The terms “partially invert” and “partially inverted”, for purposes herein, refer to a configuration in which portions of filaments are retracted within the braided conductive member such that they are at least partially surrounded by other portions of filaments. A tip, or other portions of the braided conductive member may protrude distally from any distally-facing surface of the braided conductive member when the braided conductive member is partially inverted.

FIG. 5 illustrates braided conductive member 28 in a second deployed configuration option which may be used to effect contact between an annular surface of braided conductive member 28 and a cardiac wall (see, for example, FIG. 11) other cardiac tissue, or other target tissue. In FIG. 5, the distal tip of braided conductive member 28 is inverted. The terms “invert” or “inverted”, for purposes herein, refer to a configuration in which the distal tip or distal end of the braided conductive member is retracted such that the distal tip does not protrude distally from a distally-facing surface of the braided conductive member. For purposes herein, the terms “evert” or “everted” refer to a configuration in which the distal tip or distal end of the braided conductive member protrudes distally from any distally-facing annular surface that is present. An everted configuration does not, however, require that a distally-facing annular surface be present. In some embodiments, such as the embodiment illustrated in FIG. 2, the braided conductive member is fully elongated in an everted configuration. The term “completely everted”, when referring to a distal region of a braided conductive member, refers to a configuration in which no portion of the distal region of the braided conductive member is inverted within itself.

A braided conductive member adjustment element, such as a cable 22, is attached to distal end 18 of braided conductive member 28. Cable 22 may extend through a lumen (not shown) in shaft portion 12 and through the interior of braided conductive member 28. Cable 22 may be attached to distal end 18 of braided conductive member 28

- 9 -

using cap 24, an anchor band, or any suitable attachment or anchoring element or method known in the art. At the control handle end, cable 22 may be attached to a control element, such as a slide actuator for example, that allows a user to retract and advance cable 22. It should be noted that cable 22 is a separate element from cables 1, 3 and 6.

5 Of course, braided conductive member adjustment element need not be a cable as any suitable element for adjusting the braided conductive member may be used. For example, a sheath may be used to push the braided conductive member over the distal tip of the braided conductive member to invert braided conductive member 28.

In operation, moving cable 22 in the proximal direction causes braided
10 conductive member 28 to compress longitudinally and/or to expand radially, as shown in FIG. 3. Further proximal movement of cable 22 causes a portion of braided conductive member 28 to invert as shown in FIG. 4. Even further proximal movement of cable 22 may retract distal end 18 such that distal end 18 is encircled by a portion of braided conductive member 28. In some embodiments, distal end 18 may be surrounded or
15 partially surrounded by a portion of braided conductive member 28 that does not form a circle.

In some embodiments, a certain amount of movement of cable 22 in the proximal direction may occur without user actuation due to the bias of the braided conductive member 28. For example, braided conductive member 28 may be longitudinally
20 extended beyond a relaxed state by radially compressing braided conductive member 28 with a sheath 33 (see FIG. 2). Upon retraction of sheath 33, braided conductive member 28 may radially expand a certain amount due to its filament winding structure, or due to elastic or spring elements attached to the filaments. In further embodiments, cable 22 may be used to urge braided conductive member 28 back into a longitudinally extended
25 state by pushing on cap 24 or other distal attachment portion.

By retracting distal end 18 of braided conductive member 28 at least a certain distance in the proximal direction, a braided conductive member annular surface 30 may be formed in a plane that is substantially perpendicular to a distal end 26 of shaft portion 12, as illustrated in FIG. 4. Retracting distal end 18 further removes the projection of
30 distal end 18 beyond annular surface 30, as illustrated in FIG. 5, which may allow annular surface 30 to be placed in contact with a cardiac wall or other cardiac tissue. If braided conductive member 28 is only partially inverted and distal end 18 projects

- 10 -

beyond annular surface 30 in the distal direction, it may hinder efforts to contact cardiac tissue with the annular surface. In some embodiments, however, it may be desirable to maintain a portion of distal end 18 projecting from braided conductive member 28 so that braided conductive member 28 may be positioned relative to an ostium by inserting
5 distal end 18 into the ostium. In some embodiments, the annular surface may be arranged such that it is contactable to a substantially flat area of tissue that has no ostia, even though an element may protrude distally from the annular surface. For example, a highly flexible element, such as a touch sensor, may protrude distally from the inverted braided conductive member and the annular surface would still be arranged such that it is
10 contactable to a substantially flat area of tissue that has no ostia. The touch sensor may be a bend sensor that is positioned on the distal tip of the braided conductive member and protrudes slightly from the distally-facing surface when the braided conductive member is put into a deployed configuration. The bend sensor bends upon encountering a tissue wall and signals the controller that it has bent. The flexibility of the bend sensor allows
15 the braided conductive member to contact the wall.

For purposes herein, a "surface" of braided conductive member 28 refers to a plurality of interlaced conductive elements, such as filaments or wires, even though the interlaced elements may not fully occupy the space considered to be the surface. In some embodiments, wires or other conductive elements may be attached to or embedded in a
20 flexible support material such that a solid surface is present.

The annular surface formed by inverting the braided conductive member 28 may have electrodes spaced around the entire annular surface. In other embodiments, electrodes may be positioned only on a portion or portions of the ring-shaped surface.

As illustrated in FIGS. 2-5, a sheath 33 may be provided. Sheath 33 serves to
25 protect shaft portion 12 and braided conductive member 28 during manipulation through the patient's vasculature. In addition, sheath 33 may shield braided conductive member 28 from the patient's tissue in the event ablation energy is prematurely delivered to the braided conductive member 28.

Sheath 33 may be advanced and retracted over shaft portion 12 in any suitable
30 manner. Control handle 14 may be used to effect the advancement or retraction of sheath 33. U.S. Pat. Nos. 5,383,852, 5,462,527, and 5,611,777, which are herein incorporated by reference in their entireties, illustrate examples of control handles that can control

- 11 -

sheath 33. As described in these patents, control handle 14 may include a slide actuator which is axially displaceable relative to the handle. The slide actuator may be connected to sheath 33 to retract sheath 33 to expose braided conductive member 28 once the distal end of the catheter has been positioned within the heart or other target location.

5 Braided conductive member 28 may be shape or biased such that when sheath 33 is retracted, braided conductive member 28 expands slightly in the radial direction. In other embodiments, braided conductive member 28 may maintain its longitudinally extended shape until cable 22 or other adjustment element is pulled in the proximal direction to longitudinally compress braided conductive member 28. In still other
10 embodiments, braided conductive member 28 may maintain a radial size similar to its relaxed state radial size when distal tip 18 is moved proximally, or even when braided conductive member 28 is inverted.

Braided conductive member 28 is, in one embodiment of the invention, a plurality of interlaced, electrically conductive filaments 34. In some embodiments,
15 braided conductive member 28 is a wire mesh. The filaments 34 are preferably formed of metallic elements having relatively small cross sectional diameters, such that the filaments are flexible and the braided conductive member can be expanded radially outwardly. In one embodiment, the filaments may be round in cross-section, having a dimension on the order of about 0.001-0.030 inches in diameter. Alternatively, the
20 filaments may have flat sides in cross-section, with thicknesses on the order of about 0.001-0.030 inches, and widths on the order of about 0.001-0.030 inches. The filaments may be formed of nitinol-type wire or other shaped memory alloys. Alternatively, the filaments may include non-metallic elements woven with metallic elements, with the non-metallic elements providing support to and/or separation of the metallic elements. A
25 multiplicity of individual filaments 34 may be provided in braided conductive member 28, for example three hundred or more filaments. Instead of a multiplicity or plurality of filaments, a smaller number of filaments, or even only one continuous filament may be arranged to form braided conductive member 28. For purposes herein, the terms
"filaments" or "plurality of filaments" may refer to one continuous filament that is
30 interlaced with itself to form a braided conductive member.

Each of the filaments 34 may be electrically isolated from each other by an insulation coating. This insulation coating may be, for example, a polyamide type

- 12 -

material. In one manner of forming an electrode, a portion of the insulation on the filaments forming an outer circumferential surface of braided conductive member 28 is removed. This arrangement allows each of the filaments 34 to form an isolated electrode, not in electrical contact with any other filament, that may be used for mapping and ablation. In some embodiments, an electrode may contact a coated section of another filament. Alternatively, specific electrodes may be permitted to contact each other to form a preselected grouping. Methods of removing insulation from filaments 34 are disclosed in PCT Publication No. WO 02/087437, which is herein incorporated by reference in its entirety. The insulation may also be removed in a preferential manner so that a particular portion of the circumferential surface of a filament 34 is exposed. In this manner, when braided conductive member 28 is radially expanded, the stripped portions of filaments may preferentially face an intended direction of mapping or ablation.

Further, in some embodiments some of filaments 34 may be used for mapping or electrical measurement, while others of filaments 34 may be used for ablation. The mapping and ablation filaments may be activated independently or may be activated concurrently. One application of dedicating some filaments for mapping and others for ablation is using a single braided conductive member 28 to both form a lesion and measure the quality of the lesion. Such an arrangement can avoid a change of catheters during a medical procedure. Temperature sensors (not shown) also may be included on catheter shaft 12 or braided conductive member 28.

A wire (not shown) may run from each of the filaments 34 to connector portion 16 via conductors (not shown). A multiplexer or switch box (see, for example, switch matrix 1230, FIG. 12) may be connected to the conductors so that each filament 34 may be controlled individually. This function may be incorporated into controller 8. In some embodiments, a number of filaments 34 may be grouped together for mapping and ablation. Alternatively, each individual filament 34 may be used as a separate mapping channel for mapping individual electrical activity at a single point. Using a switch box or multiplexer to configure the signals being received by filaments 34 or ablation energy sent to filaments 34 results in a large number of possible combinations of filaments for detecting electrical activity during mapping procedures and for applying energy during an ablation procedure.

- 13 -

Catheter 10 may also have a reference electrode (not shown) mounted on shaft 12 so that the reference electrode is located outside the heart during unipolar mapping operations.

Individual control of the electrical signals received from filaments 34 allows catheter 10 to be used for bipolar (differential or between filament) type mapping as well as unipolar (one filament with respect to a reference electrode) type mapping.

Catheter 10 may be a steerable device, in some embodiments, in that the distal end 26 may be deflected by an actuator contained within control handle 14. Control handle 14 may include a rotatable thumb wheel which can be used by a user to deflect distal end 26 of the catheter. The thumb wheel (or any other suitable actuating device) is connected to one or more pull wires (not shown) which extend through shaft portion 12 and connect to distal end 18 of the catheter at an off-axis location, whereby tension applied to one or more of the pull wires causes the distal portion of the catheter to curve in a predetermined direction or directions. U.S. Pat. Nos. 5,383,852, 5,462,527, and 5,611,777 illustrate various embodiments of control handle 14 that may be used for steering catheter 10.

In some embodiments, a proximal portion of braided conductive member 28 includes support elements to aid in maintaining the shape and/or structural integrity of portions of braided conductive member 28 when distal end 18 is moved in the proximal direction. For example, support elements may include support filaments 34' that are stronger, thicker or more rigid at their proximal ends than at their distal ends, as illustrated in FIG. 6. In other embodiments, splines 35 or other non-filament elements may be included, such as by interlacing support elements among filaments 34, as illustrated in FIG. 7. In still further embodiments, support elements which are not interlaced with filaments 34 may be included. In some embodiments, support elements attach to a proximal anchoring element 32 at a first end and to cap 24 or filaments 34 at a second end.

Referring to FIG. 7, an embodiment of the invention having a longitudinally asymmetrically shaped braided conductive member 28 is illustrated. In this embodiment, a maximum diameter 36 of braided conductive member 28 is located closer to distal end 18 than to proximal anchoring element 32. In one embodiment, maximum diameter 36 is longitudinally located more than two-thirds of the way from the proximal anchoring

- 14 -

location to the distal attachment location. As cable 22 is drawn in the proximal direction to move cap 24, splines 35 support the more proximal region of braided conductive member 28.

Reference is now made to FIG. 8 which illustrates another shape of braided
5 conductive member 28. As described above regarding various embodiments of the invention, braided conductive member 28 may be generally radially symmetrical. However, certain anatomical structures may have complex three-dimensional shapes that are not easily approximated by a geometrically symmetrical mapping or ablation structure. To successfully contact these types of anatomical structures, braided
10 conductive member 28 can be "preformed" to a close approximation of that anatomy, and yet still be flexible enough to adapt to variations found in specific patients. Alternatively, braided conductive member 28 can be of sufficient strength (as by choice of materials, configuration, etc.) to force the tissue to conform to variations found in specific patients. For example, FIG. 8 illustrates braided conductive member 28
15 disposed about shaft 12 in an off-center or non-concentric manner such that braided conductive member 28 is radially asymmetrically-shaped. In addition, braided conductive member 28 may also be constructed so that the annular surface of the braided conductive member in its expanded configuration is a non-circular surface so as to improve tissue contact. FIG. 8 illustrates an example of this type of configuration where
20 the braided conductive member 28 is constructed and arranged to be non-concentric with respect to a longitudinal axis of braided conductive member 28 and also, in its expanded configuration, to have an asymmetric shape. In some embodiments, the asymmetric expanded configurations and the eccentricity of braided conductive member 28 with respect to the longitudinal axis can be produced by providing additional structural
25 supports in braided conductive member 28, for example, by adding nitinol wire, ribbon wire, splines, and so on. Other suitable methods of creating the eccentric and/or asymmetric shape include: varying the winding pitch; varying individual filament size and/or placement; deforming selective filaments in braided conductive member 28; and any other suitable method known to those skilled in the art.

30 An asymmetrically-shaped braided conductive member may allow for the formation of a ring-shaped surface that is disposed at an angle to general longitudinal direction of the braided member and/or the distal end of the catheter. The angled surface

- 15 -

may permit better contact with certain tissue areas. In still other embodiments, inverting the braided conductive member may form a non-planar surface. For example, differing filament diameters may allow for the formation of a ring-shaped surface which includes a section that is substantially perpendicular to the catheter and a section that is disposed
5 at an angle to the catheter. The angle of the surface relative to the catheter may change continuously across the surface in still other embodiments.

In some embodiments of the present invention, catheter 10 may be coated with a number of coatings that enhance the operating properties of braided conductive member 28. The coatings may be applied by any of a number of techniques and the coatings may
10 include a wide range of polymers and other materials.

Braided conductive member 28 may be coated to reduce its coefficient of friction, thus reducing the possibility of thrombi adhesion to the braided conductive member as well as the possibility of vascular or atrial damage. These coatings can be combined with insulation (if present) on the filaments that make up braided conductive member 28.
15 These coatings may be included in the insulation itself, or the coatings may be applied over the insulation layer.

Braided conductive member 28 also may be coated to increase or decrease its thermal conduction, which can improve the safety or efficacy of the braided conductive member 28. This change in thermal conduction may be achieved by incorporating
20 thermally conductive elements or thermally insulating elements into the electrical insulation of the filaments that make up braided conductive member 28, or by adding a coating to the assembly. Polymer mixing, IBAD, or similar technology could be used to add Ag, Pt, Pd, Au, Ir, Cobalt, and others into the insulation or to coat braided
conductive member 28.

In some embodiments, radioopaque coatings or markers may be used to provide a
25 reference point for orientation of braided conductive member 28 when viewed during fluoroscopic imaging. The materials that provide radiopacity include, for example, Au, Pt, Ir, and others known to those skilled in the art. These materials may be incorporated and used as coatings as described above.

30 Antithrombogenic coatings, such as heparin and BH, can also be applied to braided conductive member 28 to reduce thrombogenicity to prevent blood aggregation

- 16 -

on braided conductive member 28. These coatings can be applied by dipping or spraying, for example.

As noted above, the filament 34 of braided conductive member 28 may be constructed of metal wire materials. These materials may be, for example, MP35N, nitinol, or stainless steel. Filaments 34 may also be composites of these materials in combination with a core of another material such as silver or platinum. The combination of a highly conductive electrical core material with another material forming the shell of the wire allows the mechanical properties of the shell material to be combined with the electrical conductivity of the core material to achieve better and/or selectable performance. The choice and percentage of core material used in combination with the choice and percentage of shell material used can be selected based on the desired performance characteristics and mechanical/electrical properties desired for a particular application.

There may be times during ablation or mapping procedures when catheter 10 passes through difficult or tortuous vasculature. During these times, it may be helpful to have a guiding sheath (not shown) through which to pass catheter 10 so as to allow easier passage through the patient's vasculature.

Irrigation

It is known that for a given electrode side and tissue contact area, the size of a lesion created by radiofrequency (RF) energy is a function of the RF power level and the exposure time. At higher powers, however, the exposure time can be limited by an increase in impedance that occurs when the temperature at the electrode-tissue interface approaches 100° C. One way of maintaining the temperature less than or equal to this limit is to irrigate the ablation electrode with saline to provide convective cooling so as to control the electrode-tissue interface temperature and thereby prevent an increase in impedance. Accordingly, irrigation of braided conductive member 28 and the tissue site at which a lesion is to be created can be provided in the present invention. FIG. 9 illustrates the use of an irrigation manifold within braided conductive member 28. An irrigation manifold 100 is disposed along shaft 12 inside braided conductive member 28. Irrigation manifold 100 may be one or more polyimide tubes. Within braided conductive member 28, the irrigation manifold splits into a number of smaller tubes 102 that are woven into braided conductive member 28 along a respective filament 34. A series of

- 17 -

holes 104 may be provided in each of the tubes 102. These holes can be oriented in any number of ways to target a specific site or portion of braided conductive member 28 for irrigation. Irrigation manifold 100 runs through catheter shaft 12 and may be connected to an irrigation delivery device outside the patient used to inject an irrigation fluid, such as saline, for example, such as during an ablation procedure.

The irrigation system can also be used to deliver a contrast fluid for verifying location or changes in vessel diameter. For example, a contrast medium may be perfused prior to ablation and then after an ablation procedure to verify that there have been no changes in the blood vessel diameter. The contrast medium can also be used during mapping procedures to verify placement of braided conductive member 28. In either ablation or mapping procedures, antithrombogenic fluids, such as heparin can also be perfused to reduce thrombogenicity. FIG. 10 illustrates another way of providing perfusion/irrigation in catheter 10. As illustrated in FIG. 10, the filaments 34 that comprise braided conductive member 28 may be composed of a composite wire 110. The composite wire 110 includes a lumen 114 containing an electrically conductive wire 112 that is used for delivering ablation energy in an ablation procedure or for detecting electrical activity during a mapping procedure. Composite wire 110 also contains a perfusion lumen 116. Perfusion lumen 116 is used to deliver irrigation fluid or a contrast fluid as described in connection with FIG. 9. Once braided conductive member 28 has been constructed with composite wire 110, the insulation 118 surrounding wire filament 112 can be stripped away to form an electrode surface. Holes can then be provided in perfusion lumen 116 to then allow perfusion at targeted sites along the electrode surface. As with the embodiment illustrated in FIG. 9, the perfusion lumens can be connected together to form a manifold which manifold can then be connected to, for example, perfusion tube 120 and connected to a fluid delivery device.

Methods Of Use

Reference is now made to FIG. 11 which illustrates how a catheter according to certain embodiments of the present invention may be used in endocardial applications.

In an endocardial procedure, shaft portion 12 is introduced into a patient's heart 150. Appropriate imaging guidance (direct visual assessment, camera port, fluoroscopy, echocardiographic, magnetic resonance, etc.) can be used. FIG. 11 in particular illustrates shaft portion 12 being placed in the left atrium of the patient's heart, though a

- 18 -

catheter using a braided conductive member 28 is well suited for mapping and ablating in other structures, such as ventricles, particularly near the ventricular outflow tract. Once shaft portion 12 reaches the patient's left atrium, sheath 33 may be retracted and braided conductive member 28 may be inverted to its deployed state, where, in the illustrated
5 embodiment, braided conductive member 28 forms a cone-type shape including a distally-facing, ring-shaped surface. External pressure may be applied along shaft portion 12 to achieve the desired level of contact between braided conductive member 28 and the cardiac tissue. In one embodiment, mapping of electrical impulses may be achieved with braided conductive member 28. In another embodiment, energy is applied
10 to the cardiac tissue in contact with braided conductive member 28 to create an annular lesion. The energy used may be RF (radiofrequency), DC, microwave, ultrasonic, cryothermal, optical, etc.

In some embodiments, the braided conductive member may be configured such that it forms a distally-facing, ring-shaped surface before the braided conductive member
15 is introduced to the heart.

Controller

FIG. 12 shows further details of an embodiment of the controller 8 of FIG. 1. In this embodiment, the controller includes a computer 1210. Computer 1210 has a display
20 1216 through which computer 1210 may provide a graphical user interface through which a user may input commands or receive information gathered by the electrophysiology system. For example, the user interface allows a user to operate the system to apply electrical signals to braided conductive member 28 during a method of diagnosing or treating an arrhythmia.

Computer 1210 may be used in the performance of procedures and data
25 processing operations, such as are described in copending patent applications, such as an application entitled METHODS FOR PROCESSING ELECTROCARDIAC SIGNALS HAVING SUPERIMPOSED COMPLEXES published as US 2002-0091330 A1 on July 11, 2002; an application entitled SOFTWARE CONTROLLED
ELECTROPHYSIOLOGY DATA MANAGEMENT published as US 2002-0065459 A1
30 on May 30, 2002; an application entitled MULTI-COLOR DISPLAY OF CLOSELY PROXIMATE AND OVERLAPPING CARDIAC SIGNALS, published as WO 2005/008418 A2 on January 27, 2005, all of which are hereby incorporated by reference.

- 19 -

Computer 1210 may be a standard computer, such as is widely used in business settings, with a standard operating system that executes desired application programs. Such a computer may be equipped with data acquisition and control boards, as are known in the art, to receive data and control other components of a system.

5 Alternatively, computer 1210 may be a custom designed computer having a form factor and other characteristics customized for use in an electrophysiology laboratory. Such a computer may contain one or more general purpose or special purpose processors that may be integrated with data acquisition and control hardware. However, the specific construction of computer 1210 is not a limitation of the invention.

10 Computer 1210 includes user input devices which may include a touch pad, a touch screen, a pointing wheel, buttons and/or other devices. In the illustrated embodiment, computer 1210 includes a keyboard 1212 and a mouse 1214 that serve as user input devices. Mouse 1214 may serve as a user interface selection device that works in cooperation with a graphical user interface presented on display 1216. A user may use
15 known motions, such as moving mouse 1214 to place a cursor over an object appearing as part of the graphical user interface and “clicking” on the object to invoke a function associated with that object.

Computer 1210 typically includes at least some form of computer readable media. Computer readable media can be any available media that can be accessed by
20 Computer 1210. By way of example, and not limitation, computer readable media may comprise computer storage media and communication media. Computer storage media includes volatile and nonvolatile, removable and non-removable media implemented in any method or technology for storage of information such as computer readable instructions, data structures, program modules or other data. Computer storage media
25 includes, but is not limited to, RAM, ROM, EEPROM, flash memory or other memory technology, CD-ROM, digital versatile disks (DVD) or other optical storage, magnetic cassettes, magnetic tape, magnetic disk storage or other magnetic storage devices, or any other medium which can be used to store the desired information and which can accessed by Computer 1210. Communication media typically embodies computer readable
30 instructions, data structures, program modules or other data in a modulated data signal such as a carrier wave or other transport mechanism and includes any information

- 20 -

delivery media. Combinations of the any of the above should also be included within the scope of computer readable media.

Computer-readable media may contain computer-executable instructions that cause computer 1210 to generate signals that control operation of the electrophysiology system or to gather and process data from the system. Computer-executable instructions may be in mutiple forms, such as program modules, executed by one or more computers or other devices. Generally, program modules include routines, programs, objects, components, data structures, etc. that perform particular tasks or implement particular abstract data types. Typically the functionality of the program modules may be combined or distributed as desired in various embodiments.

The computer-executable instructions may program computer 1210 to perform multiple functions as are known in the art or are as described in greater detail herein. Computer 1210 may, for example, issue control signals to configure braided conductive member 28 to perform specific operations. Braided conductive member 28 includes multiple electrically active sites. In use, the electrically active sites may be used to apply electrical signals or measure signals from a heart or other structure in contact with a surface of braided conductive member 28. Such electrically active sites may, for example, be formed by stripping insulation from conductive filaments forming braided conductive member 28. Braided conductive member 28 may be configured by connecting selected ones of the conducting filaments 34 to specific components of the electrophysiology system. Switch matrix 1230 allows these connections to be made under control of computer 1210.

In the illustrated embodiment, the electrophysiology system includes an RF generator 124 that may be used to generate an RF signal for ablation. RF generator 124 may be connected through switch matrix 1230 to cable 6, which contains wires that connect to the electrically conductive filaments 34. Switch matrix 1230 may be controlled by computer 1210 to connect RF generator 124 to any one or more of the electrically conductive filaments 34. In this embodiment, RF controller 1242 is used to extract information from connections made through catheter 10. For example, controller 1242 may detect impedances and temperates at the catheter to monitor an ablation process. RF controller 1242 may also be used to control the power level applied. For example, controller 1242 may provide a lower power while the system of FIG. 12 is

- 21 -

configured for pace mapping and a higher power when the system is configured for ablation.

Similarly, recording device 2 is coupled through switch matrix 1230 to cable 6. In this way, computer-executable instructions associated with computer 1210 may
5 configure, at any time, each of the electrically active sites to provide a stimulus signal to apply an ablation signal, to take a measurement or to perform no function.

Computer 1210 may also receive inputs from other components of the electrophysiology system. For example, computer 1210 is shown connected to a navigation system 1250. Navigation system 1250 may be a navigation system as is
10 known in the art. Such a system may output values representing the position of a catheter during a mapping or ablation procedure. Computer 1210 may also receive inputs from ECG system 1260. Such a system may be used in a pace mapping procedure. During pace mapping, stimulus signals provided to the heart through catheter
10 may be detected externally through ECG system 1260. Computer 1210, may use this
15 information to determine whether the applied stimulus triggered a response that is similar to the ECG measured for a patient during an arrhythmia episode.

Computer 1210 provides a user interface on display 1216 that may facilitate the use of electrophysiology system as pictured in FIG. 12, particularly one that includes a catheter that can be configured. In particular, braided conductive member 28 provides a
20 substrate on which multiple electrically active sites are mounted. In use, the catheter is configured by selectively accessing groups of the electrically active sites.

FIGs. 13A and 13B illustrate an embodiment in which a graphical user interfaced is used in configuring a catheter. The graphical user interface allows the electrically active sites to be accessed in one of multiple ways. Each electrically active site may be
25 accessed individually. Alternatively, the electrically active sites may be formed into groups. The groups may then be accessed individually or may be accessed according to a pattern specified by a user.

Turning to FIG. 13A, a window 1310 such as may appear on display 1216 is illustrated. Window 1310 includes a menu bar 1330 that allows a user to specify the
30 operating mode of the electrophysiology system in which the site groupings specified are used. In this example, the electrophysiology system may be used for passive mapping, pace mapping or ablation. Accordingly, menu bar 1330 includes a control 1332,

- 22 -

allowing the user to specify a configuration for passive mapping procedures. Window 1310 likewise includes controls 1334 and 1336 which allow the user to specify a site group for pace mapping procedures and ablation procedures, respectively. Window 1310 includes graphical component 1320 representing the catheter. The individual electrically active sites are indicated by controls such as those indicated at 1322A and 1322B. In this embodiment, each electrically active site has a corresponding control displayed in window 1310.

In the mode displayed in FIG. 13A, a user may access an electrically active site individually. Any suitable method may be used to receive user input indicating a selection of a specific electrically active site. In the illustrated embodiment, traditional “point and click” commands are used. A user may manipulate mouse 1214 or other user input selection device attached to computer 1210 to position a cursor 1340 over the control indicating the selective electrically active site. By “clicking” the mouse or otherwise indicating a selection, the user may specify that the electrically active site corresponding to the control be accessed.

Such a user interface may be implemented using programming techniques as are known in the art. For example, traditional software systems with graphical user interfaces associate program elements with controls appearing on a computer display. When a user selects a specific control, the software associated with the control is executed. In the example of FIG. 13A, selecting a control representing an electrically active site may, for example, execute software on computer 1210 that sends a signal to switch matrix 1230 to connect that electrically active site to RF generator 1240. However, the specific action taken in response to a user selection of an electrically active site may depend on the operating mode selected. For example, when the user has selected a passive mapping operating mode through menu choice 1332, the software executed in response to this selection may connect the selectively active site to recording device 2.

FIG. 13B shows an alternative user interface that may be used to access electrically active sites in groups. FIG. 13B shows a window 1350 that may, for example, appear on display 1216 as part of a graphical user interface presented to an operator of the electrophysiology system of FIG. 12. Window 1350 includes multiple controls, each representing a group of electrically active sites on a catheter that is used in

- 23 -

connection with the electrophysiology system. In the illustrated example controls 1351, 1352 and 1353 are shown, representing three subgroups of electrically active sites that have been defined. However, the number of groups is not a limitation on the invention. Computer 1210 may be programmed to add or remove controls as subgroups of
5 electrically active sites are defined.

FIG. 13B shows one way in which electrically active sites may be assigned to each of the subgroups. A drop down list box 1360 is shown in connection with control 1353 corresponding to one of the groups of electrically active sites. In this example, drop down list 1360 includes an entry for each possible electrically active site that may
10 be added to the third subgroup. For simplicity of illustration only entries 1361 and 1362 are numbered. Each entry such as 1361 and 1362 includes a checkbox such as 1371 or 1372. The check box may itself be a control through which a user using the graphical user interface may provide input. By "clicking" on the checkbox, a user may specify that a site belongs to the group. By "clicking" on a checkbox that is already checked, the
15 user may specify that a site should be removed from the group.

A drop down list box may be associated with each of the controls 1351, 1352 and 1353 may be accessed in any suitable way. Where a multi-button mouse is used, the drop down list such as drop down list 1360, for example, may be accessed by pressing the right button on the mouse when cursor 1340 is positioned over a control such as
20 1353. However, any suitable method of assigning electrically active sites to groups, including receiving text input, may be used.

Once groups of electrically active sites have been defined, the groups may be used in controlling the electrophysiology system. For example, accessing one of the controls through the user interface, such as by "clicking" on one of the controls 1351,
25 1352 or 1353, may cause all of the electrically active sites defined to be in the group to be accessed. In a pace mapping mode, accessing a group may cause all of the electronically active sites in that group to be connected to RF generator 1240 through switch matrix 1230. In passive mapping mode, accessing a group may cause each of the electrically active sites in that group to be connected through switch matrix 1232 to
30 recording device 2.

Once groups of electrically active sites have been defined, groups may be accessed in an order and with the timing specified by the user. One way for a user to

- 24 -

specify the timing and access to groups of sites is by manipulating cursor 1340 to indicate one of the controls such as 1351, 1352, or 1353 associated with a group. The user may manually use a selection device, such as a button on mouse 1214, to select the control. Upon selecting a control, the electrically active sites in the group associated in
5 the group associated with that control may be accessed. In this way, the groups will be accessed in an order specified by the user at times specified by the user.

Computer 1210 may alternatively be programmed to provide an alternative method for a user to specify the order and timing of access to groups of electrically active sites. For example, computer 1210 may implement a user interface in which the
10 controls such as control 1351, 1352, and 1353 are movable objects on the graphical user interface. In this embodiment, the user may specify the order of access to the groups by moving the controls into a desired order.

The user may specify timing of access to the groups in any suitable way. For example, computer 1210 may provide a user interface with an input section (not shown),
15 through which the user may specify a time when each group of electrically active sites is accessed. Alternatively, computer 1210 may receive inputs that specify the duration for which each group is accessed or the delay between accesses of successive groups. The information about ordering and timing of access to the groups, regardless of how specified by the user, creates a form of program that may be executed by the
20 electrophysiology system of FIG. 12. Accordingly, window 1350 includes a control 1370 that the user may access. Access and control 1370 may, for example, invoke a program that accesses groups of electrically active sites in the order and with the timing specified by the user. Such a function may be used in the course of a mapping procedure to gather data intended to identify the focus of an arrhythmia. Alternatively, such a
25 procedure may be used in connection with an ablation procedure where the focus of the arrhythmia has been identified and a specific pattern of applied RF energy has been selected for treating the arrhythmia.

Turning now to FIG. 14, a process of accessing groups of electrically active sites is illustrated. The process of FIG. 14 may, for example, be implemented by software
30 programmed in computer 1210. The process begins at block 1410 where a group is specified. A group may be specified by input from a user. The user input may be

- 25 -

obtained through a graphical user interface as depicted in FIGs. 13A and 13B. However, any suitable method of specifying a group may be used.

The process illustrated in FIG. 14 continues to decision block 1412. If it is determined at decision block 1412 that further groups remain to be specified, processing
5 loops back to step 1410.

When there are no further groups to specify, processing continues to block 1414. At block 1414, the electrophysiology system waits until the programmed time for the first group to be processed is reached. At the programmed time, processing proceeds to block 1416. At block 1416 the electrophysiology system is configured for the group
10 being processed. In the example of FIG. 12, configuration may include providing control information to switch matrix 1230. Other devices within the electrophysiology system may likewise be controlled to obtain the desired configuration.

At block 1418, the desired function of the electrophysiology system is applied. In this block, the function may be applied by providing an RF signal of the appropriate
15 magnitude or by making a measurement from each of the electrically active sites in the subgroup, depending on the specific operating mode of the system.

The process proceeds to decision block 1420. At decision block 1420 it is determined if there are more groups of electrically active sites to be processed. If more groups remain, processing returns to block 1414. The process waits at block 1414 until
20 the time for processing the next group. At that time, the process in blocks 1416, 1418, and decision block 1420 is repeated.

In this way, the electrophysiology system allows a user to control a catheter with electrically multiple active sites. Flexible control is provided to allow the user to access these sites singly or in groups and in a manual or automated fashion. Such control
25 capability when combined with a catheter that has multiple electrically active sites on a substrate that may cover a relatively large area, speeds procedures performed with the electrophysiology system.

For example, the above described U.S. Published application, US 2002/0065459-A1, entitled "SOFTWARE CONTROLLED ELECTROPHYSIOLOGY DATA
30 MANAGEMENT" describes the use of a roving catheter. That patent application describes managing discrete data capture requests throughout the course of an electrophysiology procedure. A catheter as described above having a plurality of

- 26 -

electrically active sites that may be selected in groups may be used in place of a roving catheter. Rather than repositioning a roving catheter between independent data capture events, different groups of the electrically active sites may be selected without moving the catheter. The selection of groups may be made in response to manual user inputs or
5 may be performed programmatically based on a predefined sequence for accessing groups of electrically active sites.

As another example, published U.S. Patent Application US 2002/0091330-A1, entitled "METHODS FOR PROCESSING ELECTROCARDIAC SIGNALS HAVING SUPERIMPOSED COMPLEXES" describes a reference ECG waveform compared to an
10 ECG waveform captured during pace mapping. As part of such a method, a quality of match indicator is computed. For pace mapping, the heart is stimulated with a roving intercardiac catheter. A catheter having a plurality of individually accessible electrically active sites as described above may be used to perform such a procedure without moving a roving catheter. Rather, stimulus may be provided to the heart in a predictable, defined
15 manner by selecting groups of the electrically active sites on a single catheter.

More generally the catheter and controller described above may be used in any procedure where accessing different locations is desired. The access may be to sense signals in a passive mapping procedure. Alternatively, the access may be to supply signals, such as in a pace mapping or ablation process. Regardless of the specific
20 purpose of the access, allowing access in a predictable, defined manner is advantageous. It avoids the random "hit and miss" approach that characterizes many current procedures in which locations in the heart are accessed through manipulation of a tip of a catheter.

Having thus described several aspects of at least one embodiment of this invention, it is to be appreciated that various alterations, modifications, and
25 improvements will readily occur to those skilled in the art. Such alterations, modifications, and improvements are intended to be part of this disclosure, and are intended to be within the spirit and scope of the invention. Accordingly, the foregoing description and drawings are by way of example only.

What is claimed is:

- 27 -

CLAIMS

1. A computer-readable medium comprising computer-executable instructions for controlling an electrophysiology system of the type having a catheter with a plurality of electrically active sites, the computer-executable instructions for performing acts of:
- 5
- (a) providing at least one display area through which a user may specify a set of the electrically active sites to be used in sensing signals from the heart;
 - 10 (b) providing at least one display area through which a user may specify a set of the electrically active sites to be used in sending stimulation signals to the heart; and
 - (c) providing at least one display area through which a user may specify a set of the electrically active sites to be used in sending an ablation signal to the heart.
- 15
2. The computer-readable medium of claim 1, wherein the act (a) comprises providing at least one display area having a graphical representation of the plurality of electrically active sites.
- 20
3. The computer-readable medium of claim 2, wherein providing a graphical presentation of each of the plurality of electrically active sites comprises displaying on a computer display a control associated with the plurality of electrically active sites.
- 25
4. The computer-readable medium of claim 1, wherein the act (a) comprises providing at least one display area in response to a user selection of a passive mapping mode.
- 30
5. The computer-readable medium of claim 1, wherein the act (c) comprises providing at least one display area in response to the user activating a control to place the electrophysiology system in a ablation mode.

- 28 -

- 5 6. A computer-readable medium comprising computer-executable instructions for controlling an electrophysiology system of the type having a catheter with a plurality of electrically active sites, the computer-executable instructions for performing acts of:
- (a) for each of a plurality of sets of electrically active sites, receiving from a user a specification of the electrically active sites in the set;
 - (b) receiving from the user a specification of a specified order of the plurality of sets; and
 - 10 (c) for each of the sets, successively in the specified order, controlling the electrophysiology system to access the electrically active sites of the set.
- 15 7. The computer-readable medium of claim 6, wherein the act (a) comprises the acts of:
- (i) providing a graphical user interface displaying a visual representation of the catheter and the plurality of electrically active sites;
 - (ii) receiving user input through the graphical user interface specifying selected ones of the electrically active sites.
- 20 8. The computer-readable medium of claim 6, wherein the act (b) comprises the acts of:
- (i) providing a graphical user interface with a selection area associated with each of the plurality of sets;
 - 25 (ii) receiving a plurality of successive user inputs indicating a selection area; and
 - (iii) deriving the specified order of sets from an order in which the user accesses the specification areas.
- 30 9. The computer-readable medium of claim 8, wherein the act (c) comprises controlling the electrophysiology system to access the electrically active sites of the set as each of the plurality of successive user inputs is received.

10. The computer-readable medium of claim 8, wherein the act (c) comprises the acts of:

(i) recording the order of the plurality of user inputs at a first time;

5 and

(ii) at a second time, later than the first time, for each of the sets, successively in the recorded order, controlling the electrophysiology system to access the electrically active sites of the set.

10 11. The computer readable medium of 10, wherein the computer executable instructions additionally perform the act of;

(d) capturing an ECG waveform in synchronization with successive accesses for each of the sets of electrically active sites.

15 12. In an electrophysiology system having a catheter with a plurality of electrically active sites and a computer having a graphical user interface including a display and a user interface selection device, a method of providing and selecting from a menu on the display, comprising the acts of:

(a) displaying on the display a graphical representation of each of the plurality of electrically active sites on the catheter;

20 (b) receiving at least one selection signal indicative of the user interface selection device pointing at a graphical representation of a selected one of the plurality of electrically active sites; and

(c) controlling the electrophysiology system to selectively access at least one of the electrically active sites based on the at least one selection signal.

25 13. The electrophysiology system of claim H1, wherein the act (c) comprises controlling the electrophysiology system to selectively apply a stimulus signal to at least one of the electrically active sites based on the at least one selection signal.

30

- 30 -

14. The electrophysiology system of claim 12, wherein the act (c) comprises controlling the electrophysiology system to selectively apply a pace mapping signal.

5 15. The electrophysiology system of claim 13, wherein the act (c) comprises controlling the electrophysiology system to selectively apply an ablation signal.

16. The electrophysiology system of claim 13, wherein the method additionally comprises the act of;

10 (d) capturing dating in conjunction with the selective access of the at least one of the electrically active sites.

17. The electrophysiology system of claim 12, wherein:

15 the method additionally comprises the act of (d) receiving a user input specifying an operating mode of the system; and

the act (c) comprises selectively driving or receiving a signal through at least one of the electrically active sites based on the user input specifying an operating mode.

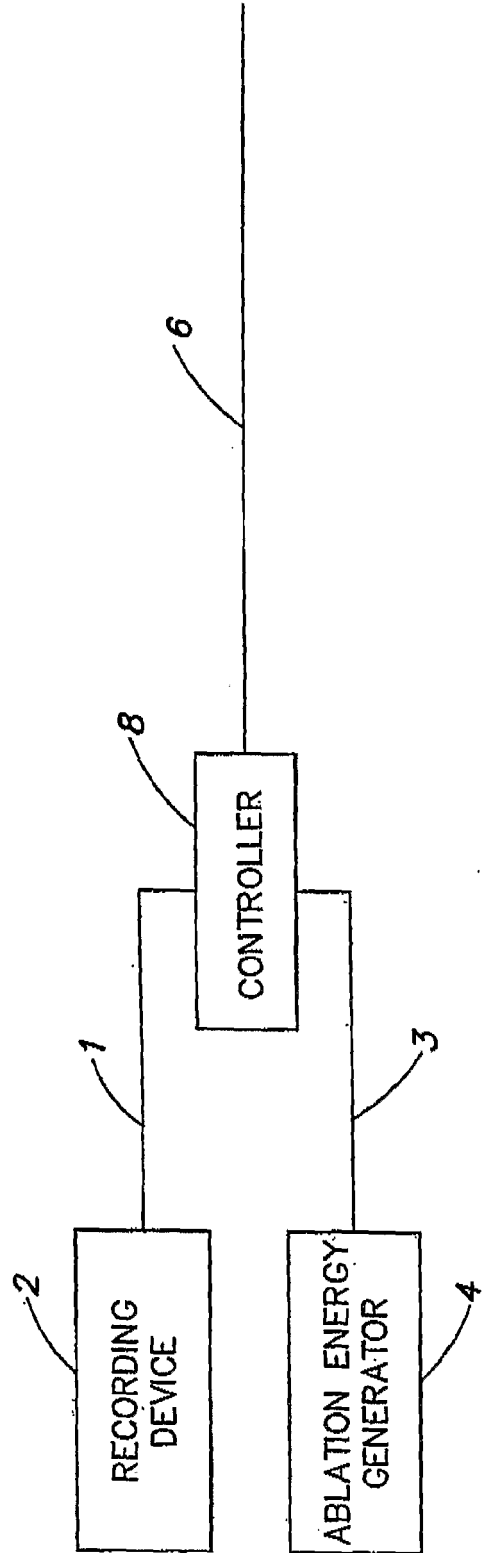
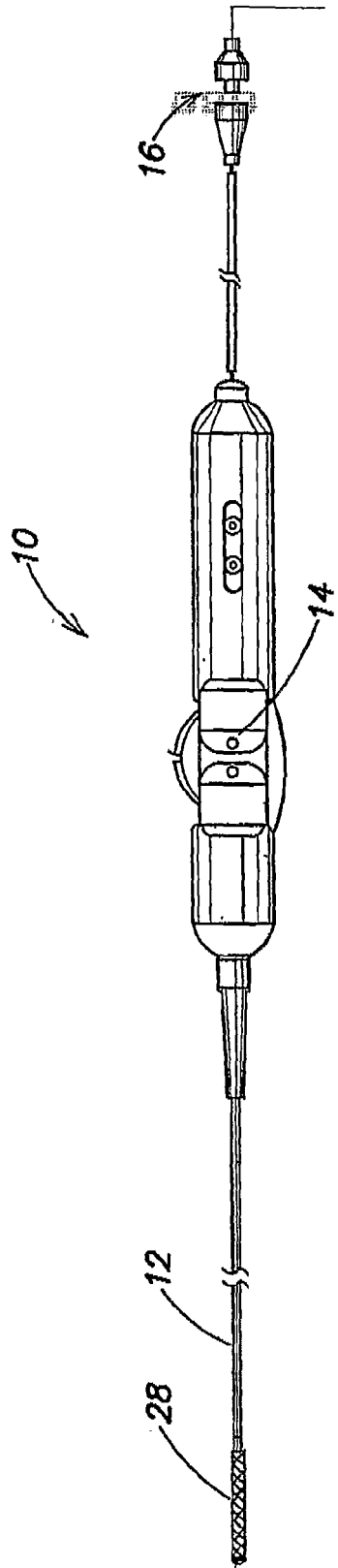

FIG. 1

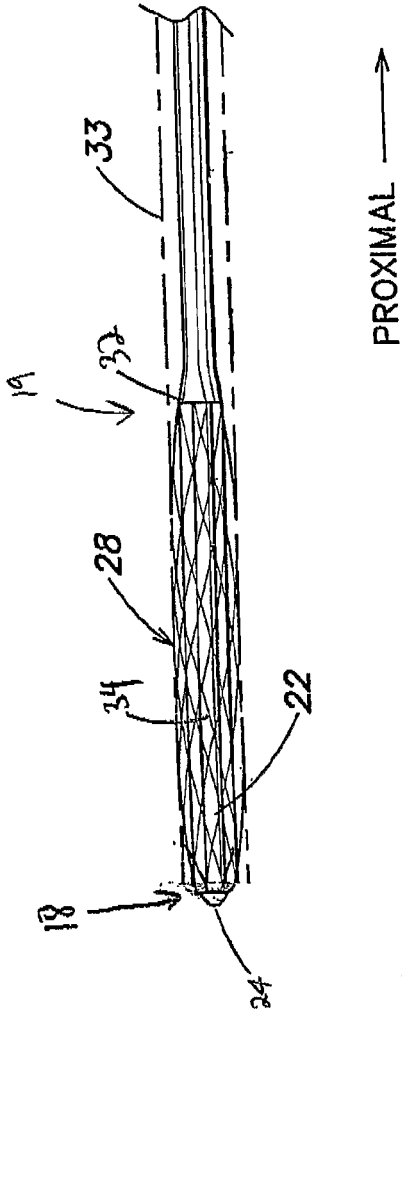

FIG. 2

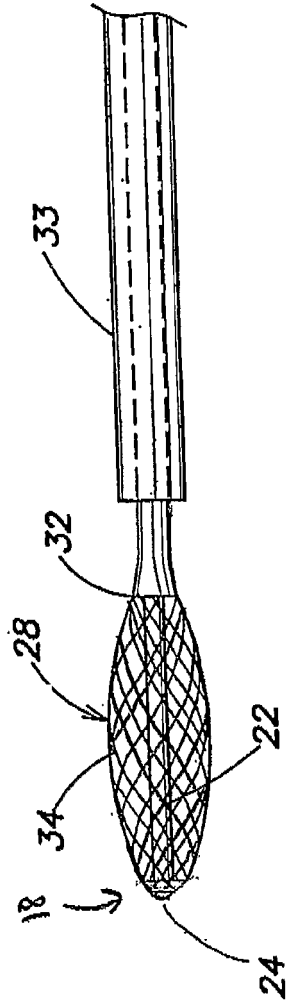

FIG. 3

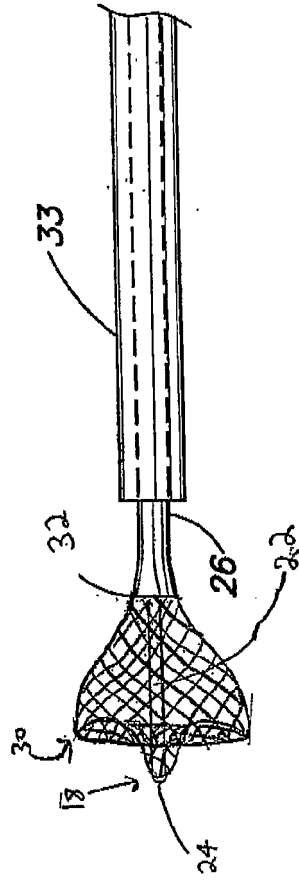

FIG. 4

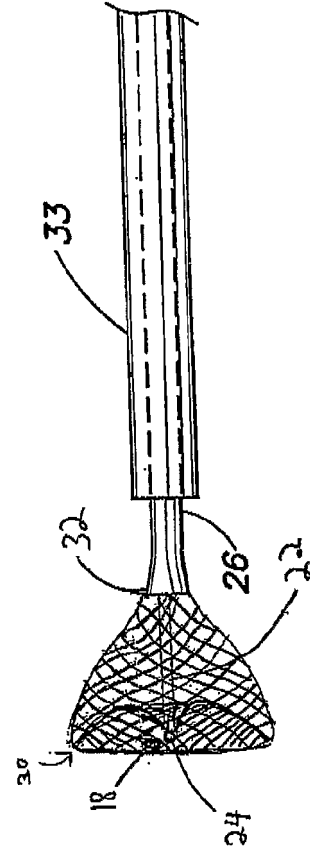

FIG. 5

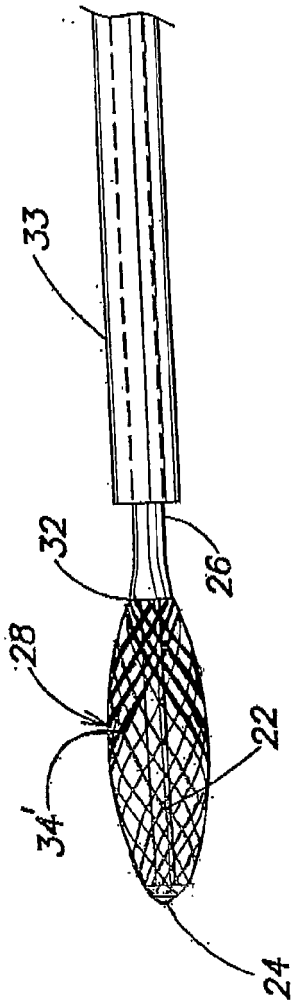

FIG. 6

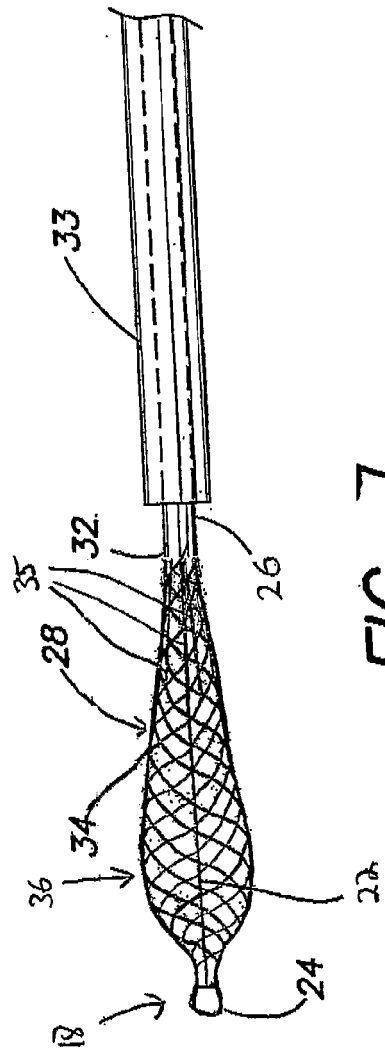

FIG. 7

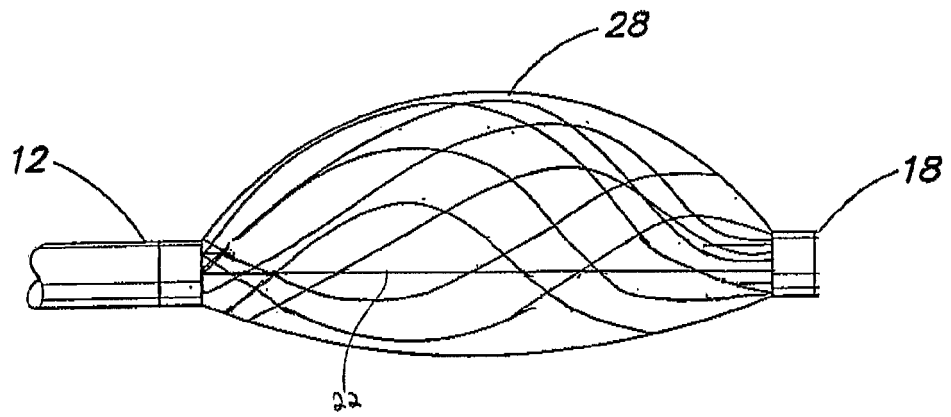

FIG. 8

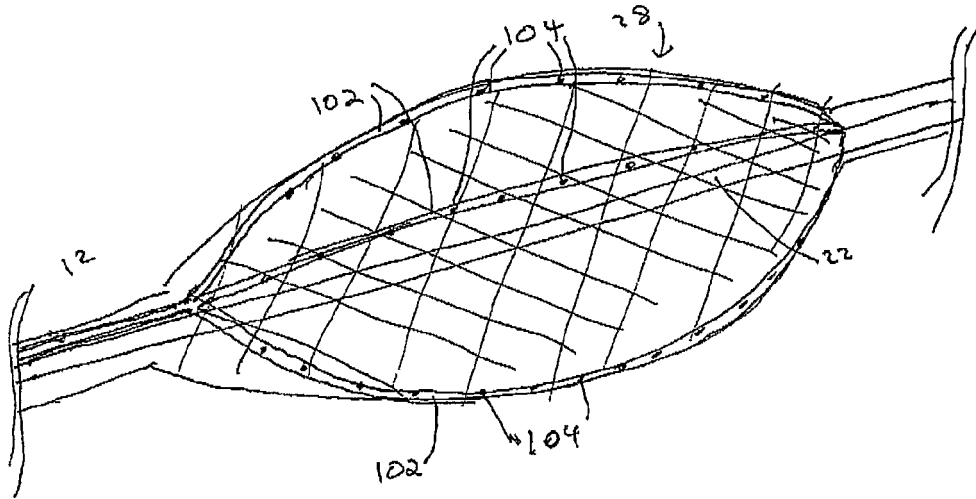

Fig. 9

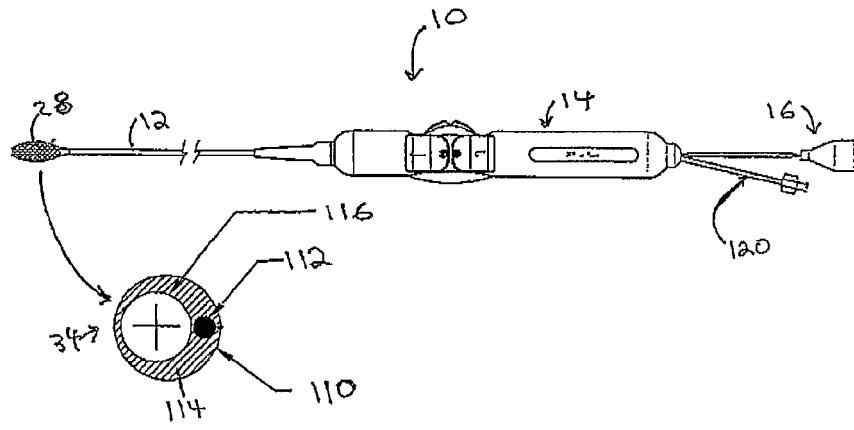

Fig. 10

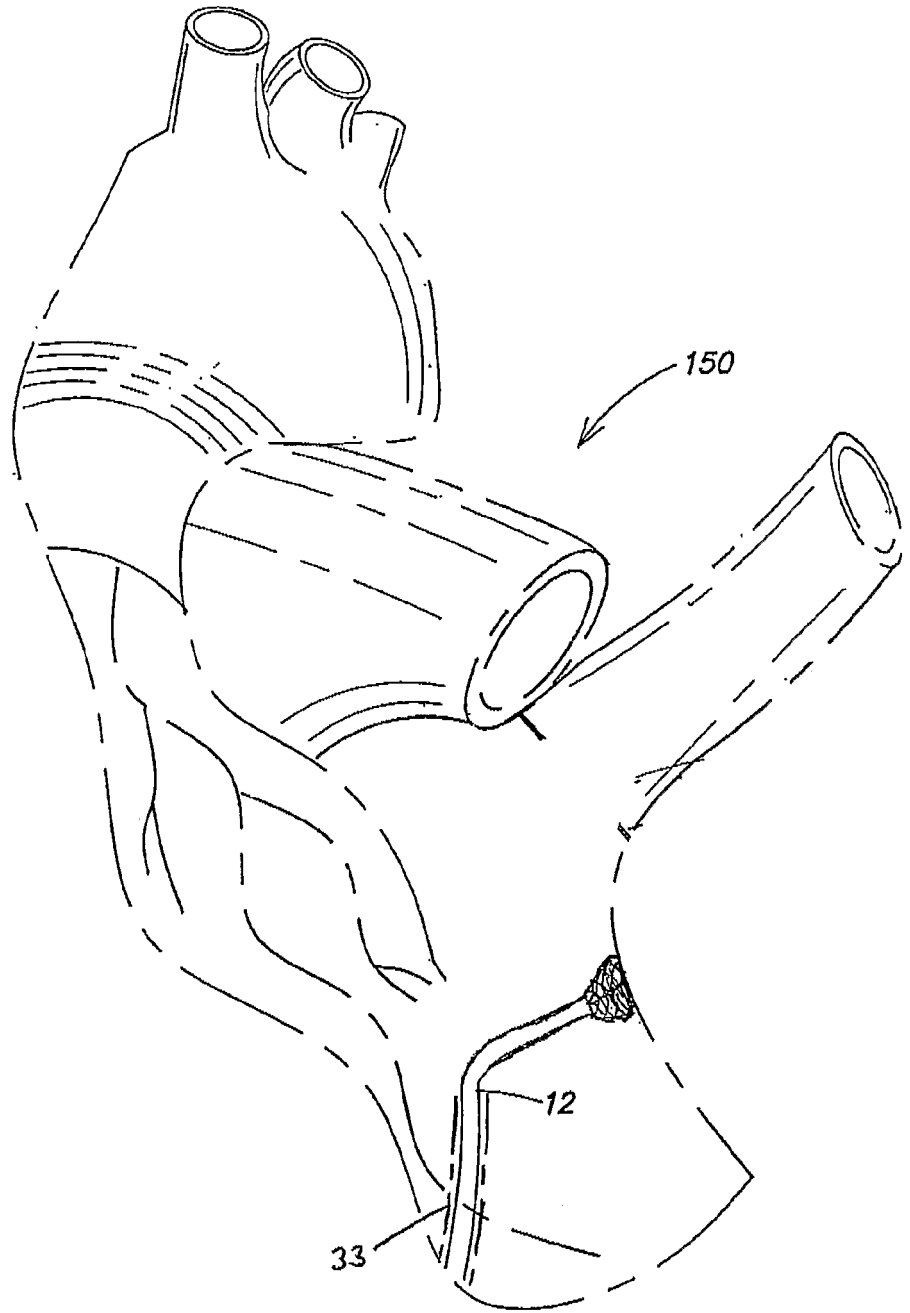

FIG. 11

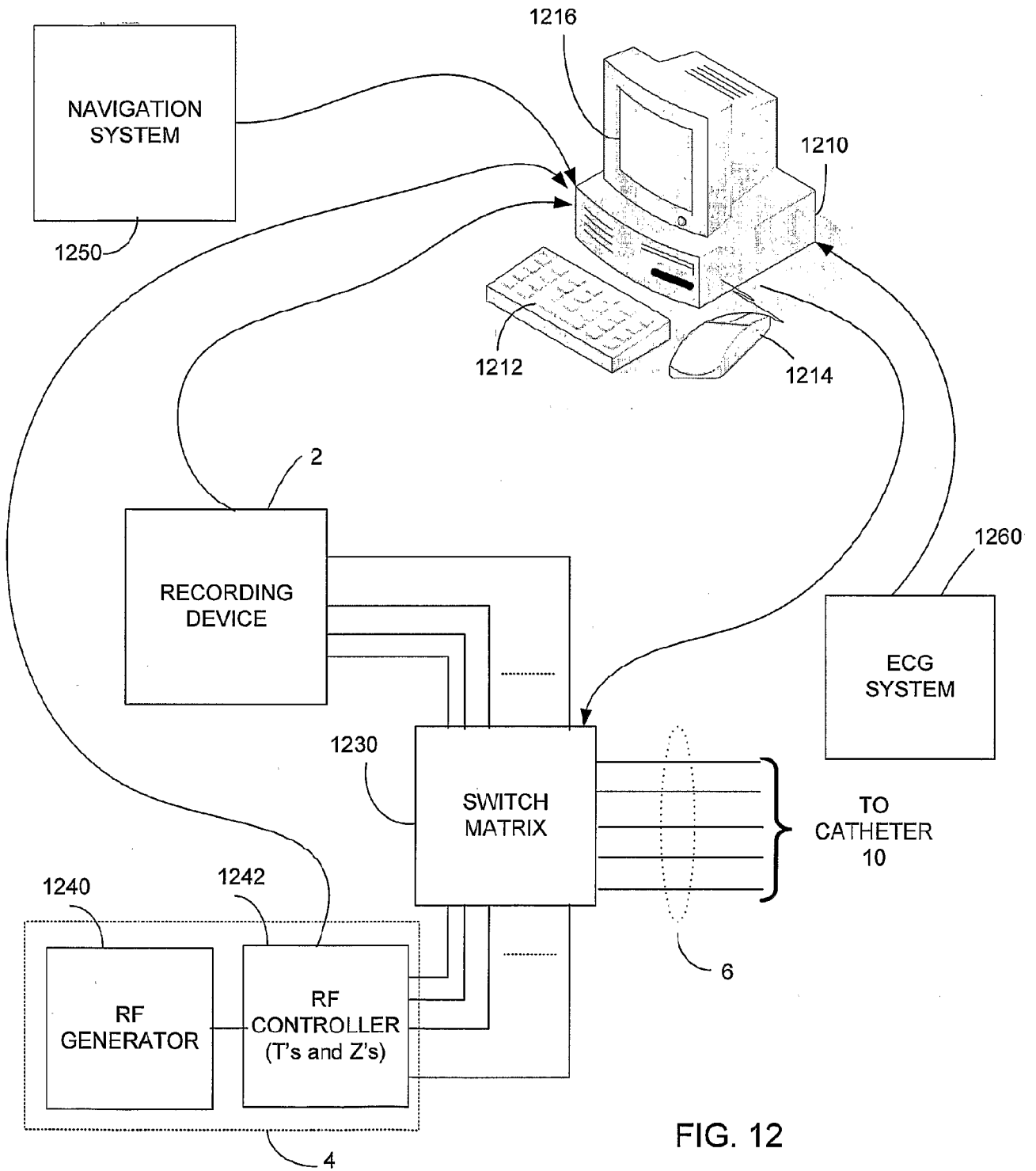

FIG. 12

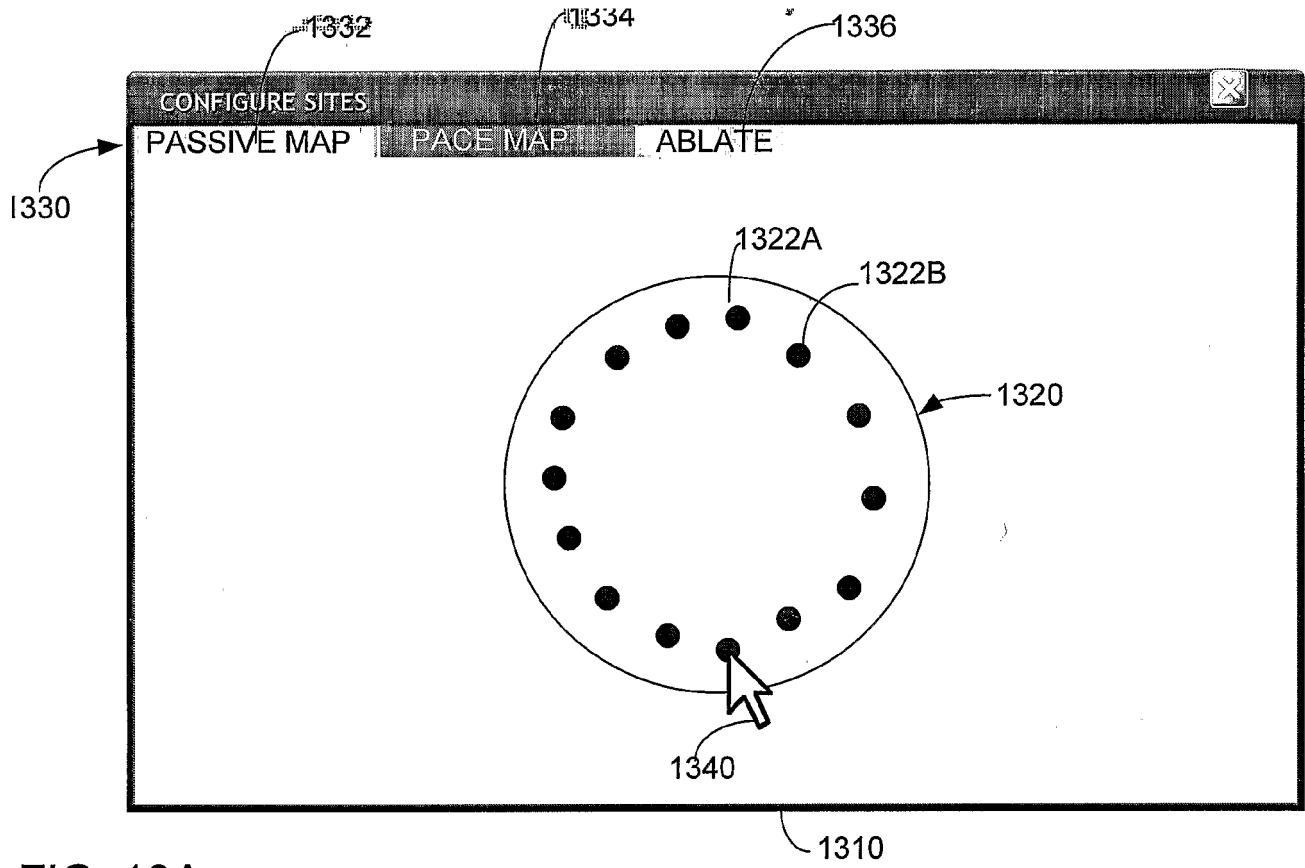

FIG. 13A

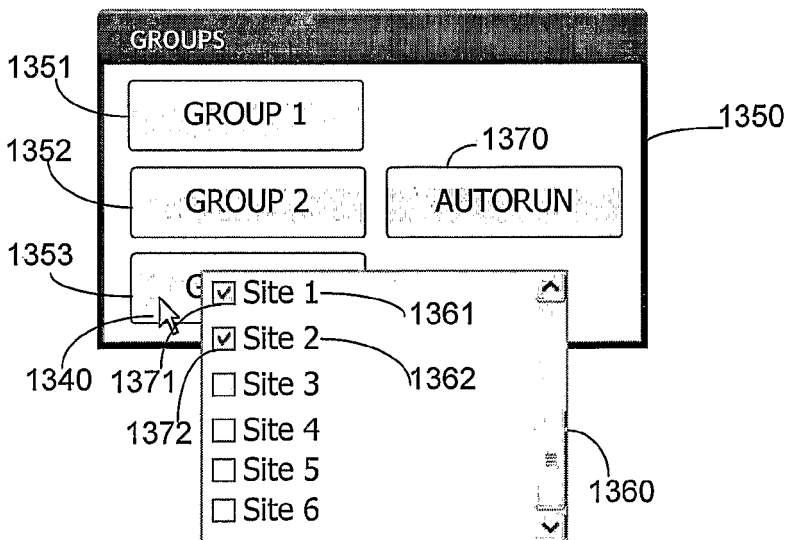

FIG. 13B

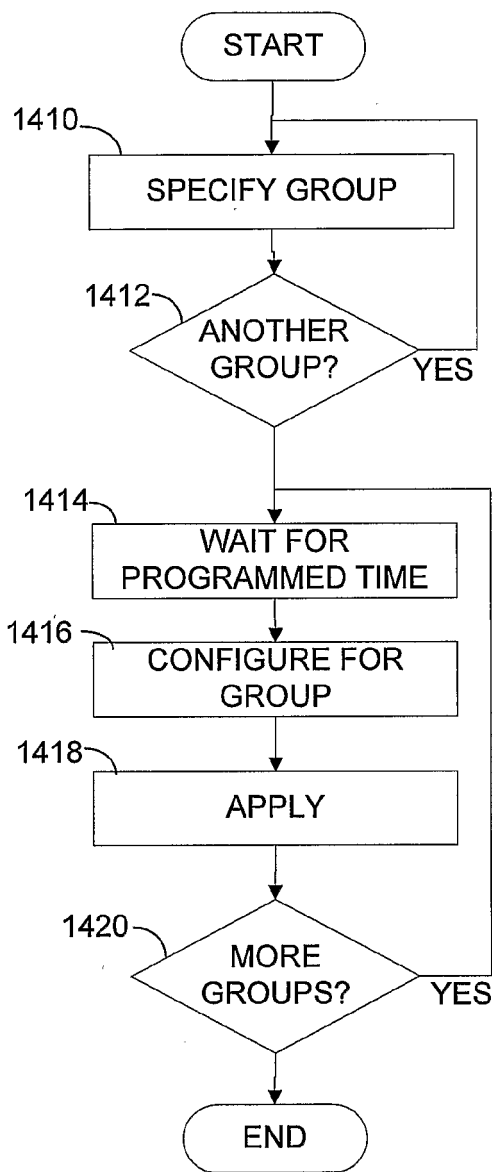

FIG. 14

INTERNATIONAL SEARCH REPORT

International application No.

PCT/US05/17080

<p>A. CLASSIFICATION OF SUBJECT MATTER IPC(7) : A61B 5/04 US CL : 600/509 According to International Patent Classification (IPC) or to both national classification and IPC</p>																				
<p>B. FIELDS SEARCHED Minimum documentation searched (classification system followed by classification symbols) U.S. : 600/509, 523, 525; 607/9; 606/41; 128/920 Documentation searched other than minimum documentation to the extent that such documents are included in the fields searched Electronic data base consulted during the international search (name of data base and, where practicable, search terms used)</p>																				
<p>C. DOCUMENTS CONSIDERED TO BE RELEVANT</p> <table border="1"> <thead> <tr> <th>Category *</th> <th>Citation of document, with indication, where appropriate, of the relevant passages</th> <th>Relevant to claim No.</th> </tr> </thead> <tbody> <tr> <td>X</td> <td>US 6,014,581 A (Whayne et al.) 11 January 2000 (11.01.2000), the whole document.</td> <td>1-7, 12-17</td> </tr> <tr> <td>X</td> <td>US 6,679,269 B2 (Swanson) 20 January 2004 (20.01.2004), col. 15, lines 7-55.</td> <td>8-11</td> </tr> <tr> <td>X</td> <td>US 5,860,920 A (McGee et al.) 19 January 1999 (19.01.1999), col. 5, line 5 - col. 12, line 9.</td> <td>12, 13, 15, 17</td> </tr> <tr> <td>A</td> <td>US 5,657,755 A (Desai) 19 August 1997 (19.08.1997), the whole document</td> <td>1-5, 12-17</td> </tr> <tr> <td>A</td> <td>US 6,049,732 A (Panescu et al.) 11 April 2000 (11.04.2000), the whole document.</td> <td>1-17</td> </tr> </tbody> </table>			Category *	Citation of document, with indication, where appropriate, of the relevant passages	Relevant to claim No.	X	US 6,014,581 A (Whayne et al.) 11 January 2000 (11.01.2000), the whole document.	1-7, 12-17	X	US 6,679,269 B2 (Swanson) 20 January 2004 (20.01.2004), col. 15, lines 7-55.	8-11	X	US 5,860,920 A (McGee et al.) 19 January 1999 (19.01.1999), col. 5, line 5 - col. 12, line 9.	12, 13, 15, 17	A	US 5,657,755 A (Desai) 19 August 1997 (19.08.1997), the whole document	1-5, 12-17	A	US 6,049,732 A (Panescu et al.) 11 April 2000 (11.04.2000), the whole document.	1-17
Category *	Citation of document, with indication, where appropriate, of the relevant passages	Relevant to claim No.																		
X	US 6,014,581 A (Whayne et al.) 11 January 2000 (11.01.2000), the whole document.	1-7, 12-17																		
X	US 6,679,269 B2 (Swanson) 20 January 2004 (20.01.2004), col. 15, lines 7-55.	8-11																		
X	US 5,860,920 A (McGee et al.) 19 January 1999 (19.01.1999), col. 5, line 5 - col. 12, line 9.	12, 13, 15, 17																		
A	US 5,657,755 A (Desai) 19 August 1997 (19.08.1997), the whole document	1-5, 12-17																		
A	US 6,049,732 A (Panescu et al.) 11 April 2000 (11.04.2000), the whole document.	1-17																		
<p><input type="checkbox"/> Further documents are listed in the continuation of Box C. <input type="checkbox"/> See patent family annex.</p>																				
<p>* Special categories of cited documents</p> <table border="0"> <tr> <td>"A" document defining the general state of the art which is not considered to be of particular relevance</td> <td>"T" later document published after the international filing date or priority date and not in conflict with the application but cited to understand the principle or theory underlying the invention</td> </tr> <tr> <td>"E" earlier application or patent published on or after the international filing date</td> <td>"X" document of particular relevance, the claimed invention cannot be considered novel or cannot be considered to involve an inventive step when the document is taken alone</td> </tr> <tr> <td>"L" document which may throw doubts on priority claim(s) or which is cited to establish the publication date of another citation or other special reason (as specified)</td> <td>"Y" document of particular relevance, the claimed invention cannot be considered to involve an inventive step when the document is combined with one or more other such documents, such combination being obvious to a person skilled in the art</td> </tr> <tr> <td>"O" document referring to an oral disclosure, use, exhibition or other means</td> <td>"&" document member of the same patent family</td> </tr> <tr> <td>"P" document published prior to the international filing date but later than the priority date claimed</td> <td></td> </tr> </table>			"A" document defining the general state of the art which is not considered to be of particular relevance	"T" later document published after the international filing date or priority date and not in conflict with the application but cited to understand the principle or theory underlying the invention	"E" earlier application or patent published on or after the international filing date	"X" document of particular relevance, the claimed invention cannot be considered novel or cannot be considered to involve an inventive step when the document is taken alone	"L" document which may throw doubts on priority claim(s) or which is cited to establish the publication date of another citation or other special reason (as specified)	"Y" document of particular relevance, the claimed invention cannot be considered to involve an inventive step when the document is combined with one or more other such documents, such combination being obvious to a person skilled in the art	"O" document referring to an oral disclosure, use, exhibition or other means	"&" document member of the same patent family	"P" document published prior to the international filing date but later than the priority date claimed									
"A" document defining the general state of the art which is not considered to be of particular relevance	"T" later document published after the international filing date or priority date and not in conflict with the application but cited to understand the principle or theory underlying the invention																			
"E" earlier application or patent published on or after the international filing date	"X" document of particular relevance, the claimed invention cannot be considered novel or cannot be considered to involve an inventive step when the document is taken alone																			
"L" document which may throw doubts on priority claim(s) or which is cited to establish the publication date of another citation or other special reason (as specified)	"Y" document of particular relevance, the claimed invention cannot be considered to involve an inventive step when the document is combined with one or more other such documents, such combination being obvious to a person skilled in the art																			
"O" document referring to an oral disclosure, use, exhibition or other means	"&" document member of the same patent family																			
"P" document published prior to the international filing date but later than the priority date claimed																				
<p>Date of the actual completion of the international search 06 October 2005 (06.10.2005)</p>		<p>Date of mailing of the international search report 15 NOV 2005</p>																		
<p>Name and mailing address of the ISA/US Mail Stop PCT, Attn: ISA/US Commissioner for Patents P.O. Box 1450 Alexandria, Virginia 22313-1450 Facsimile No. (703) 305-3230</p>		<p>Authorized officer <i>For</i> Nicole R. Kramer Telephone No. 571-272-8792</p>																		

专利名称(译)	用于绘制和消融心律失常的电生理学系统		
公开(公告)号	EP1768553A1	公开(公告)日	2007-04-04
申请号	EP2005749957	申请日	2005-05-17
申请(专利权)人(译)	C.R. BARD , INC.		
当前申请(专利权)人(译)	C.R. BARD , INC.		
[标]发明人	MACADAM DAVID HE DING SHENG		
发明人	MACADAM, DAVID HE, DING, SHENG		
IPC分类号	A61B5/04 A61B5/00 A61B5/042 A61B18/14		
CPC分类号	A61B18/1492 A61B5/042 A61B2018/00214 A61B2018/00839		
优先权	60/571843 2004-05-17 US 60/571821 2004-05-17 US 60/571781 2004-05-17 US		
其他公开文献	EP1768553A4		
外部链接	Espacenet		

摘要(译)

用于绘制和/或消融组织的电生理学系统包括具有多个电活性部位的导管。该系统包括提供用户界面的控制器，通过该用户界面可以控制多个站点。这些网站可以单独访问，也可以分组访问。另外，可以以手动或自动方式控制访问特定电活性站点的顺序和时间。