

(19) World Intellectual Property
Organization
International Bureau



(43) International Publication Date
10 February 2005 (10.02.2005)

PCT

(10) International Publication Number
WO 2005/011491 A1

- (51) International Patent Classification⁷: A61B 5/00, 5/0205
- (21) International Application Number: PCT/ZA2004/000091
- (22) International Filing Date: 4 August 2004 (04.08.2004)
- (25) Filing Language: English
- (26) Publication Language: English
- (30) Priority Data:

2003/0949	4 August 2003 (04.08.2003)	ZA
2003/6138	8 August 2003 (08.08.2003)	ZA
2003/8285	24 October 2003 (24.10.2003)	ZA
- (71) Applicant and
(72) Inventor: PIETERSEN, Johannes, de Klerk [ZA/ZA];
84 Molopo Avenue, Doringkloof, 0157 Centurion (ZA).
- (74) Agent: PEIJPER INCORPORATED; 41 Frans Oerder
Street, Groenkloof, 0181 Pretoria (ZA).
- (81) Designated States (unless otherwise indicated, for every
kind of national protection available): AE, AG, AL, AM,
AT, AU, AZ, BA, BB, BG, BR, BW, BY, BZ, CA, CH, CN,
CO, CR, CU, CZ, DE, DK, DM, DZ, EC, EE, EG, ES, FI,
GB, GD, GE, GH, GM, HR, HU, ID, IL, IN, IS, JP, KE,
KG, KP, KR, KZ, LC, LK, LR, LS, LT, LU, LV, MA, MD,
MG, MK, MN, MW, MX, MZ, NA, NI, NO, NZ, OM, PG,
PH, PL, PT, RO, RU, SC, SD, SE, SG, SK, SL, SY, TJ, TM,
TN, TR, TT, TZ, UA, UG, US, UZ, VC, VN, YU, ZA, ZM,
ZW.
- (84) Designated States (unless otherwise indicated, for every
kind of regional protection available): ARIPO (BW, GH,
GM, KE, LS, MW, MZ, NA, SD, SL, SZ, TZ, UG, ZM,
ZW), Eurasian (AM, AZ, BY, KG, KZ, MD, RU, TJ, TM),
European (AT, BE, BG, CH, CY, CZ, DE, DK, EE, ES, FI,
FR, GB, GR, HU, IE, IT, LU, MC, NL, PL, PT, RO, SE, SI,

[Continued on next page]

(54) Title: DEVICE FOR MONITORING THE CONDITION OF A HUMAN BEING

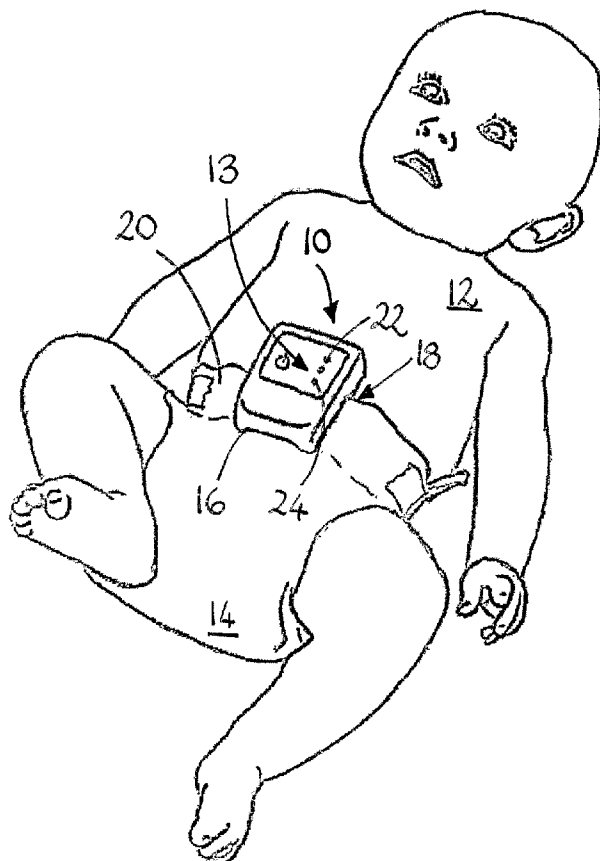

(57) Abstract: A device for continuously monitoring one or more indicators relating to the health or comfort of a person 12 includes one or more sensing means for measuring a value of one or more desired indicators and a communicating means 13 communicating an alarm signal when the measured value is above or below a predetermined value or range of values range, wherein the device 10 is adapted to be attached to an item of clothing 14 of the person 12.

WO 2005/011491 A1



SK, TR), OAPI (BF, BJ, CF, CG, CI, CM, GA, GN, GQ, GW, ML, MR, NE, SN, TD, TG).

For two-letter codes and other abbreviations, refer to the "Guidance Notes on Codes and Abbreviations" appearing at the beginning of each regular issue of the PCT Gazette.

Published:

- *with international search report*
- *before the expiration of the time limit for amending the claims and to be republished in the event of receipt of amendments*

DEVICE FOR MONITORING THE CONDITION OF A HUMAN BEING

Field of the Invention

5 This invention relates to a device for monitoring one or more indicators relating to the health or comfort of a human being and for communicating the sensed information to a caretaker of the human being.

Background to the Invention

10

Monitors for sensing the heart rate, breathing or other vital functions of a hospitalized person are well-known in the art. Devices for home use have been developed to aid in the care of infants or elderly persons to monitor breathing, heart rate, and the like. These devices are however often too complicated to be operated by an unskilled person and/ or cause
15 discomfort to the person being monitored.

In US 5,400,012, a breathing monitor is disclosed for detecting Sudden Infant Death Syndrome (SIDS) in infants caused by apnoea, which monitor includes an enclosure that is attached to the torso of an infant using a strap. The enclosure is supported by and isolated
20 from the infant's torso by a fluid filled bladder coupler such that there is no direct contact between the enclosure and the torso of the infant. A monitor including a piezoelectric element is connected to the fluid coupler and a battery powered electronic circuit contained in the enclosure flashes an LED as the infant breathes and sounds and alarm should the infant fail to exhale for a predetermined period of time. An adjustable strap connector for the strap
25 provides visual indication of the strap being correctly attached and a limited range of motion is permissible between the strap and the enclosure when the infant breathes.

In US 4,146,885 a hospital bed or mattress for infants including a respiration monitor and alarm to detect apnoea is disclosed. The infant's breathing causes slight displacements of
30 portions of its body which in turn transmit dynamic recoil forces to the bed on which the infant is resting.

The monitors disclosed in the prior art suffer from a number of drawbacks. A most basic disadvantage of known monitors is that securing the device to the body of an infant is a cumbersome task which does not encourage use of the device. Known devices are in addition uncomfortable to wear, easily become displaced in use and require a skilled user.

5

The inventor therefore believes that a need exists for a device for monitoring various indicators relating to the health or comfort of an infant or grown person and for communicating information to a caretaker of the infant or grown person and which device overcomes at least some of the disadvantages of the prior art.

10

Summary of the Invention

According to the invention, there is provided a device for continuously monitoring one or more indicators relating to the health or comfort of a person, the device including:-

15

- one or more sensing means for sensing and measuring a value of one or more desired indicators; and
- a communicating means for communicating an alarm signal when the measured value is above or below a predetermined value or range of values, wherein the device is adapted to be attached to an item of clothing of the person.

20

The desired indicator may be selected from the group including: breathing, heartbeat, temperature, and humidity.

The sensing means may be located in a housing of the device.

25

The device may include a clip extending from the housing so that it is attachable to the waistband of an item of clothing worn by the person being monitored. In the case of an infant, the device may be attached to a waistband of a diaper worn by the infant. In the case of an adult, the device may be attached to a waistband of an undergarment worn by the adult.

30

The sensing means for sensing and measuring breathing of the person may be in the form of a pressure transducer which in use is located between the item of clothing and the skin of the person wearing the device. The pressure transducer may measure pressure exerted on it by the lifting and falling of the skin of the breathing person. When the pressure exerted on the pressure transducer occurs in irregular intervals or ceases for a predetermined period of time, this may activate the communicating means.

When the pressure transducer measures pressure that occurs in irregular intervals or ceases for a predetermined period of time, it may activate a stimulating means aimed at encouraging the person to breathe normally either prior to or simultaneously with activating the communicating means. The stimulating means may be in the form of a conventional vibrating mechanism that causes the housing of the device to vibrate.

The sensing means for sensing and measuring the breathing of a person may be sufficiently sensitive to additionally sense the heartbeat of a person. When an irregular heartbeat or a cessation in heartbeat is sensed, this may activate the communicating means.

The device may include a further sensing means for sensing temperature and which in use is located between the item of clothing and the skin of the person wearing the device. The temperature sensor may continuously sense and measure temperature and may activate the communicating means should the measured temperature be below or above a predetermined value or value range.

Additionally, a sensing means for sensing temperature and which is in use located exterior the item of clothing of the person wearing the device, may be provided. The values measured by the two temperature sensors may be compared continuously so as to calculate the rate of heat loss of the person wearing the device. When the rate of heat loss falls below or rises above a predetermined value or range of values, this may activate the communicating means.

The device may include yet a further sensing means for sensing and measuring humidity and that is in use located between the item of clothing and the skin of the person wearing the

device. When the value of the humidity rises above a certain predetermined value, this may activate the communicating means.

5 Additionally, a sensing means for sensing humidity and which is in use located exterior the item of clothing of the person wearing the device, may be provided. The values measured by the two humidity sensors may be compared continuously so as to be able to ascertain when the humidity level between the item of clothing and skin of the person rises above a desired value at which stage the communicating means may be activated.

10 The humidity sensor may be in the form of a conductivity sensor. As an increase in humidity leads to an increase in conductivity, when the conductivity rises above a predetermined value, the communicating means may be activated.

15 The sensing and measuring of humidity is particularly useful when the device is used to monitor an infant, in that an increase in humidity indicates a soiled diaper which can then be changed timeously by a caretaker of the infant before any discomfort is caused.

20 The communicating means may include one or more of the following: an audible alarm, a visual signal such as a flashing light, and a radio signal transmitted to a suitable remotely located receiver.

The housing and clip may be manufactured from any suitable synthetic plastics material.

25 The device may include a power source in the form of, for example, batteries located in the housing.

30 The device may include an interface on the housing to permit setting of the various values or value ranges at which the communicating means is to be activated and for switching the device on and off. The housing may be provided with a cover for covering the interface so as to inhibit the device from accidentally being turned off or reprogrammed during use.

The device may be provided with a data storage device for storing the information sensed by the sensing means. A user may retrieve the stored data at any time for the purpose of analysis.

- 5 The invention extends to an item of clothing which includes a device as described above.

Detailed Description of the Invention

10 The invention will now be described by way of the following non-limiting examples with reference to the accompanying drawings.

In the drawings:-

15 Figure 1 shows a first isometric view of a device in accordance with the present invention;

Figure 2 shows a second isometric view of the device of Figure 1;

20 Figure 3 shows an isometric view of the device of Figure 1 in use when attached to the diaper of an infant; and

Figures 4, 5, and 6 show cross sectioned side views showing details of three alternative constructions of a device in accordance with the present invention.

25 In the drawings, reference numeral 10 generally indicates a device for continuously monitoring one or more indicators relating to the health or comfort of a person 12 in accordance with the present invention. In the embodiment shown the person 12 is an infant.

30 The device 10 includes one or more sensing means for sensing and measuring a value of one or more desired indicators and a communicating means 13 communicating an alarm signal when the measured value is above or below a predetermined value or range of values, wherein the device 10 is adapted to be attached to an item of clothing 14 of the person 12.

The desired indicator includes breathing, temperature, and humidity.

5 The sensing means is located in a housing 16 of the device 10. The device 10 includes a clip 18 extending from the housing 16 so that it is attachable to the waistband 20 of an item of clothing 14 (in this case a diaper) worn by the person 12 being monitored.

10 The sensing means for sensing and measuring breathing of the person 12 is in the form of a pressure transducer which in use is located between the item of clothing 14 and the skin of the person 12 wearing the device 10. The pressure transducer measures pressure exerted on it by the lifting and falling of the skin of the breathing person 12. When the pressure exerted on the pressure transducer occurs in irregular intervals or ceases for a predetermined period of time, this activates the communicating means 13.

15 When the pressure transducer measures pressure that occurs in irregular intervals or ceases for a predetermined period of time, it activates a stimulating means aimed at encouraging the person 12 to breathe normally either prior to or simultaneously with activating the communicating means 13. The stimulating means is in the form of a conventional vibrating mechanism that causes the housing 16 of the device 10 to vibrate.

20 The device 10 includes a further sensing means for sensing temperature and which in use is located between the item of clothing 14 and the skin of the person 12 wearing the device 10. The temperature sensor continuously senses and measure temperature and activates the communicating means 13 should the measured temperature be below or above a predetermined value or value range.

25 The device 10 includes yet a further sensing means for sensing and measuring humidity that is in use located between the item of clothing 14 and the skin of the person 12 wearing the device 10. When the value of the humidity rises above a certain predetermined value, this activates the communicating means 13.

30

The humidity sensor is in the form of a humidity sensor that measures the percentage humidity present in the air. The humidity sensor is an electronic component. When the humidity rises above a predetermined value, the communicating means 13 is activated.

5 The sensing and measuring of humidity is particularly useful when the device 10 is used according to the embodiment shown, in that an increase in humidity indicates a soiled diaper which can be changed timeously by a caretaker of the infant before any discomfort is caused as soon as the communication means 13 is activated.

10 The communicating means 13 includes an audible alarm 22 as well as a flashing light 24.

The housing 16 and clip 18 are manufactured from any suitable synthetic plastics material.

The device 10 includes a power source in the form of batteries located in the housing 16.

15

The device 10 includes an interface (not shown) on the housing 16 to permit setting of the various values or value ranges at which the communicating means 13 is to be activated and for switching the device 10 on and off. The housing 16 is provided with a cover 26 for covering the interface so as to inhibit the device 10 from accidentally being turned off or

20

Referring now to Figure 4:

25 The device 10 includes a housing 30 defining a chamber 31 for housing the electronic circuitry of the device 10. The housing 30 is manufactured from any suitable non-toxic, hypoallergenic, synthetic plastics material.

30 The device 10 includes a user interface panel 32 using known technology in electrical communication with the electronic circuitry. Detail of the user interface panel 32 (not shown) includes one or more push-button switches (of the type typically used in membrane keypads) for enabling and disabling the device, or for changing the settings of the device. The interface

panel 32 further accommodates one or more light-emitting diodes, liquid crystal displays or other components for visual indications.

An electronic printed circuit board 33 is located in the housing 30. Various components, including a power source (typically a long-life or rechargeable battery) are affixed to the board 33. For safety reasons the housing 30 of the device 10 is permanently sealed to inhibit access to the components housed therein. However, it could also be manufactured in such a way that the user can gain access to the power source in order to replace it.

A sound transducer 34 for generating an audible alarm, such as a piezo-electric element is also included in the housing 30. An opening 35 in the housing 30 permits sound generated by the sound transducer 34 to escape from the chamber 31. Other methods of generating audible alarms and transmitting them through the housing 30 are possible and need not involve an opening.

A suitable material 36 is used to affix piezo-electric element 37 to the device 10. The element 37 can also be used as a spacer to adapt the thickness of piezo-electric element 37 to the recess depth. Alternatively, the piezo-electric element 37 can also be glued directly to the device 10.

The piezo-electric element 37 is in electrical communication with the electronic circuitry of the device 10. Applying fluctuating pressure to such an element 37 generates a corresponding fluctuating electronic potential that can be measured by the circuitry.

A suitable spacer 38 between piezo-electric element 37 and an outer membrane can be incorporated.

Slot 39 is configured and dimensioned to accommodate a the top edge of a diaper, allowing the sensor to rest against the body of an infant in order to measure changes in pressure associated with, for example, breathing. Once fitted, a typical disposable diaper's "waistband" section creates a supple but snug structure around the infant's torso. As the infant breathes

its abdomen will press more and less forcefully against this waistband section of the diaper, in unison with its breathing effort. Because the device 10 is secured to this waistband section, fluctuations of the pressure exerted by the infant's abdomen will cause fluctuations of pressure against the portion of the device 10 that is located on the inside of the diaper.

5

An outer flexible membrane 40 is manufactured from a suitable material such as polyester or polycarbon. Pressure applied to this membrane 40 is transmitted through 38 (if present) to 37, allowing measurement of such pressure by the device 10.

10 Cavity 41 accommodates a sensor assembly. Cavity 41 is smaller in area than outer membrane 40, to permit an overlap 42. Outer membrane 40 is affixed to this flange by suitable means such as waterproof glue, to preventing ingress of moisture into the device 10.

15 Motor 43 includes an offset weight attached to spindle, commonly used for "silent ring" of cellular telephones. The offset weight causes a vibration when the motor 43 is energized, said vibration being transferred to the housing 30 of the device. This vibration is used to provide tactile stimulation to the skin of the infant under situations deemed necessary. Other means of causing tactile stimulation may be used.

20 Referring now to Figure 5:

In Figure 5, reference numerals 50 to 55, 59 and 63 represent the same elements as reference numerals 30 to 35, 39 and 43 in Figure 4 and will therefore not be described further.

25 A suitable substrate 56 for a sensor is provided and is typically a membrane as used in flexible electronic circuitry, i.e. polyester or polycarbonate, suitably affixed to the device 10.

30 A deposit of suitable electrically resistive material 57 such as graphite paint, typically used in electronic component manufacturing, is in electrical communication with the circuitry of the device 10. A deposit 58 of suitable electrically conductive material such as conductive silver paint, typically used in electronic component manufacturing, is located on element 60. The

deposit 58 is of a suitable size and shape corresponding to and aligned with that of deposit 57 over an area preferably stretching from the center of cavity 61 towards the edges of said cavity 61.

- 5 A flexible membrane 60, typically polyester, polycarbonate or similar as used in flexible electronic circuit manufacturing, and preferably hypoallergenic to prevent contact dermatitis covers deposits 57 and 58.

10 Pressure exerted on the membrane 60 will cause it to flex towards membrane 56. If sufficient pressure is applied, the two membranes 56 and 60 will make contact. With even more pressure, the contact area between the two membranes 56 and 60 will become larger. The electrical resistance of 57 can be measured. Forcing the two membranes 56 and 60 together will allow deposit 58 to make contact with 57. Because deposit 58 has a lower resistance than
15 resistance of deposit 57, changing the contact area between deposits 57 and 58 will cause the measured resistance of deposit 57 to change accordingly, decreasing as more of deposit 58 makes contact with it and increasing as less of deposit 58 comes into contact with it. In practice a slight bulge (not shown) introduced below deposit 57 will cause it to remain in contact with deposit 58, allowing very slight pressures on deposit 58 to be measured.

- 20 Spacer 62 between flexible membranes 56 and 60 creates a cavity of suitable dimensions. Spacer 62 can be coated with adhesive on both sides to allow easy assembly of the sensor as a unit, and can be made of the same materials used for membranes 57 and 60.

Referring now to Figure 6:

- 25 A more complicated device 10 can be made by manufacturing a cavity 65 opposite the sensor, on the inside of the "clip" section. A third membrane 66 can then be affixed to that side so that it completely covers the cavity 65. A port 64 can also be made through the clip so that it connects the cavity between this membrane with the area behind membrane 57. If the
30 port and cavity so described are then filled with fluid (and provided that portion of membrane 56 that is located underneath the graphite deposit is not permanently affixed to the housing

30 of the device 10), pressure exerted by the waistband of the diaper on membrane 66 will be transferred through the membrane by the fluid to the underside of membrane 57, pressing 57 towards 60 and allowing pressure from both sides of the clip to be measured. Such a sensor is expected to be more sensitive than those disclosed in the embodiments of Figures 4 and 5.

5

It is to be appreciated, that the invention is not limited to any specific embodiment or configuration as hereinbefore generally described or illustrated.

Claims

1. A device for continuously monitoring one or more indicators relating to the health or comfort of a person, the device including:-
- 5 - one or more sensing means for sensing and measuring a value of one or more desired indicators; and
- a communicating means for communicating an alarm signal when the measured value is above or below a predetermined value or range of values, wherein the device is adapted to be attached to an item of clothing of the person.
- 10
2. A device as claimed in claim 1, wherein the desired indicator is selected from the group including: breathing, heartbeat, temperature, and humidity.
3. A device as claimed in claim 1 or claim 2, wherein the device includes a housing for housing the sensing means.
- 15
4. A device as claimed in any one of claims 1 to 3, wherein the device includes a clip extending from the housing so that it is attachable to the waistband of an item of clothing worn by the person being monitored.
- 20
5. A device as claimed in claim 4, wherein the item of clothing is selected from the group including: a diaper, and an undergarment.
6. A device as claimed in any one of the preceding claims, wherein the sensing means for sensing and measuring breathing of the person is in the form of a pressure transducer which in use is located between the item of clothing and the skin of the person wearing the device.
- 25
7. A device as claimed in claim 6, wherein the pressure transducer measures pressure exerted on it by the lifting and falling of the skin of the breathing person and activates
- 30

the communicating means when the pressure exerted on the pressure transducer occurs in irregular intervals or ceases for a predetermined period of time.

5 8. A device as claimed in claim 7 wherein, when the pressure transducer measures pressure that occurs in irregular intervals or ceases for a predetermined period of time, it activates a stimulating means aimed at encouraging the person to breathe normally either prior to or simultaneously with activating the communicating means.

10 9. A device as claimed in claim 8, wherein, the stimulating means is in the form of a conventional vibrating mechanism that causes the housing of the device to vibrate.

10. A device as claimed in any one of claims 6 to 9, wherein the sensing means for sensing and measuring the breathing of a person is sufficiently sensitive to additionally sense the heartbeat of a person.

15 11. A device as claimed in claim 10, wherein, when an irregular heartbeat or a cessation in heartbeat is sensed, the communicating means is activated.

20 12. A device as claimed in any one of the preceding claims, wherein the device includes a further sensing means for sensing temperature and which in use is located between the item of clothing and the skin of the person wearing the device.

25 13. A device as claimed in claim 12, wherein the temperature sensor continuously senses and measure temperature and activates the communicating means should the measured temperature be below or above a predetermined value or value range.

30 14. A device as claimed in claim 12 or claim 13, wherein an additional temperature sensing means which is in use located exterior the item of clothing of the person wearing the device, is provided so that the values measured by the two temperature sensors can be compared continuously so as to calculate the rate of heat loss of the person wearing the device.

15. A device as claimed in claim 14, wherein, when the rate of heat loss falls below or rises above a predetermined value or range of values, the communicating means is activated.
- 5 16. A device as claimed in any one of the preceding claims, wherein the device includes a further sensing means for sensing and measuring humidity and that is in use located between the item of clothing and the skin of the person wearing the device.
- 10 17. A device as claimed in claim 16, wherein, when the measured value of the humidity rises above a certain predetermined value, the communicating means is activated.
- 15 18. A device as claimed in claim 16 or claim 17, wherein an additional humidity sensor which is in use located exterior the item of clothing of the person wearing the device, is provided so that the values measured by the two humidity sensors can be compared continuously so as to be able to ascertain when the humidity level between the item of clothing and skin of the person rises above a desired value at which stage the communicating means is activated.
- 20 19. A device as claimed in any one of claims 16 to 18, wherein the humidity sensor is in the form of a conductivity sensor so that when the conductivity measured rises above a predetermined value, the communicating means is activated.
- 25 20. A device as claimed in any one of the preceding claims, wherein the communicating means includes one or more of the following: an audible alarm, a visual signal such as a flashing light, and a radio signal transmitted to a suitable remotely located receiver.
- 30 21. A device as claimed in any one of claims 4 to 20, wherein the housing and clip are manufactured from any suitable synthetic plastics material.
22. A device as claimed in any one of the preceding claims, wherein the device includes a power source.

23. A device as claimed in any one of the preceding claims, wherein the device includes an interface on the housing to permit setting of the various values or value ranges at which the communicating means is to be activated and for switching the device on and off.
- 5
24. A device as claimed in claim 23, wherein the housing is provided with a cover for covering the interface so as to inhibit the device from accidentally being turned off or reprogrammed during use.
- 10
25. A device as claimed in any one of the preceding claims, wherein the device includes a data storage device for storing the information sensed by the sensing means.
26. A device as claimed in any one of the preceding claims, wherein the device is integral with an item of clothing.
- 15
27. A device according to the invention, as hereinbefore generally described.
28. A device as specifically described with reference to or as illustrated in the accompanying drawings.
- 20
29. A device including any new and inventive integer or combination of integers, substantially as herein described.

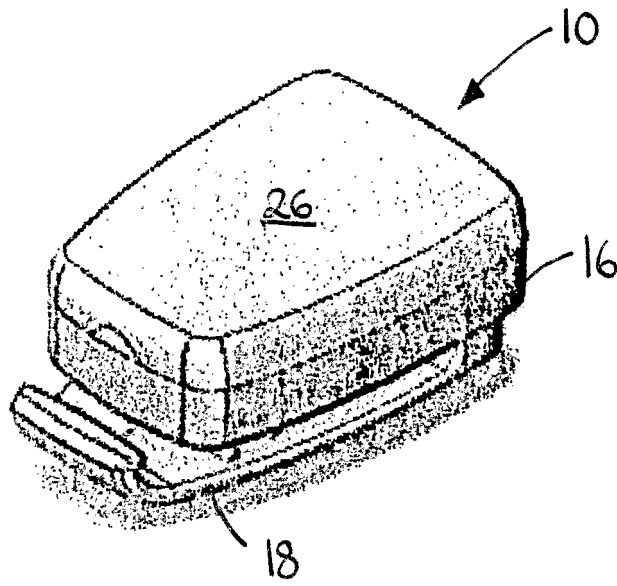

Figure 1

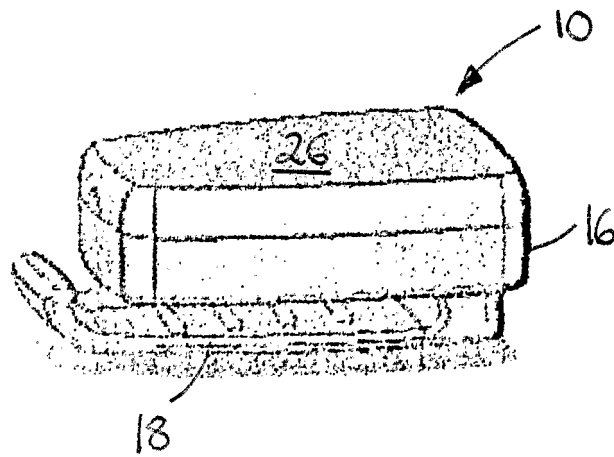

Figure 2

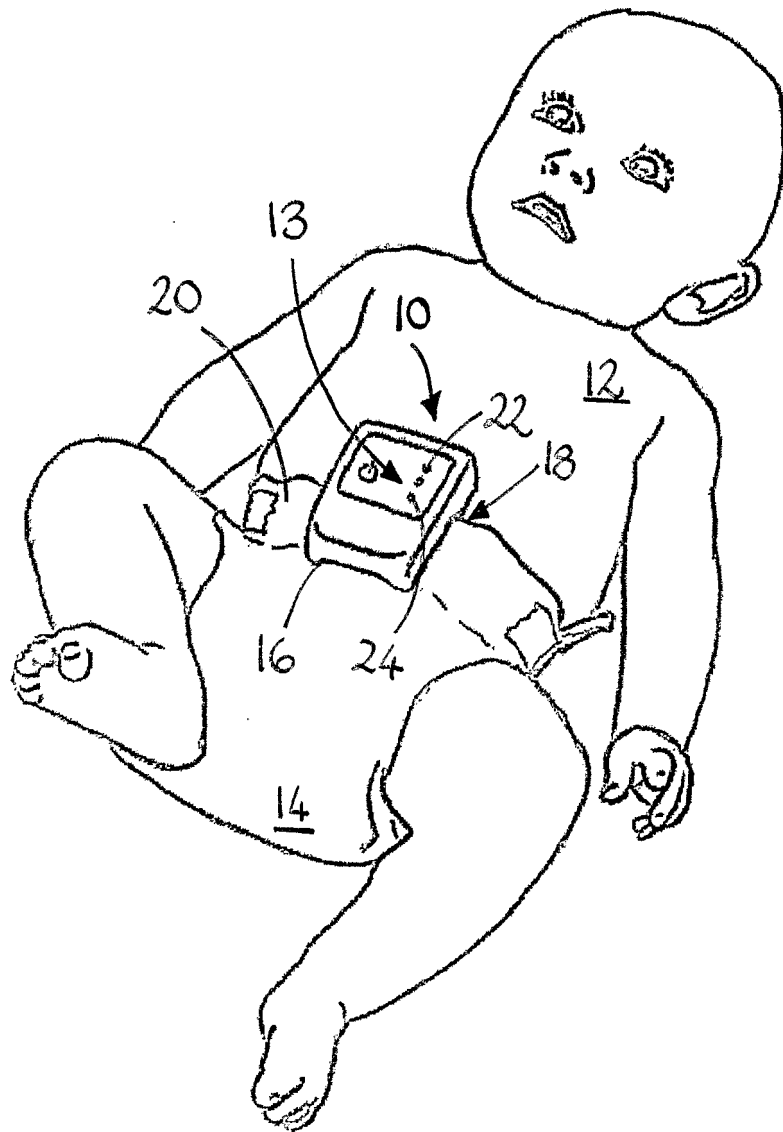

Figure 3

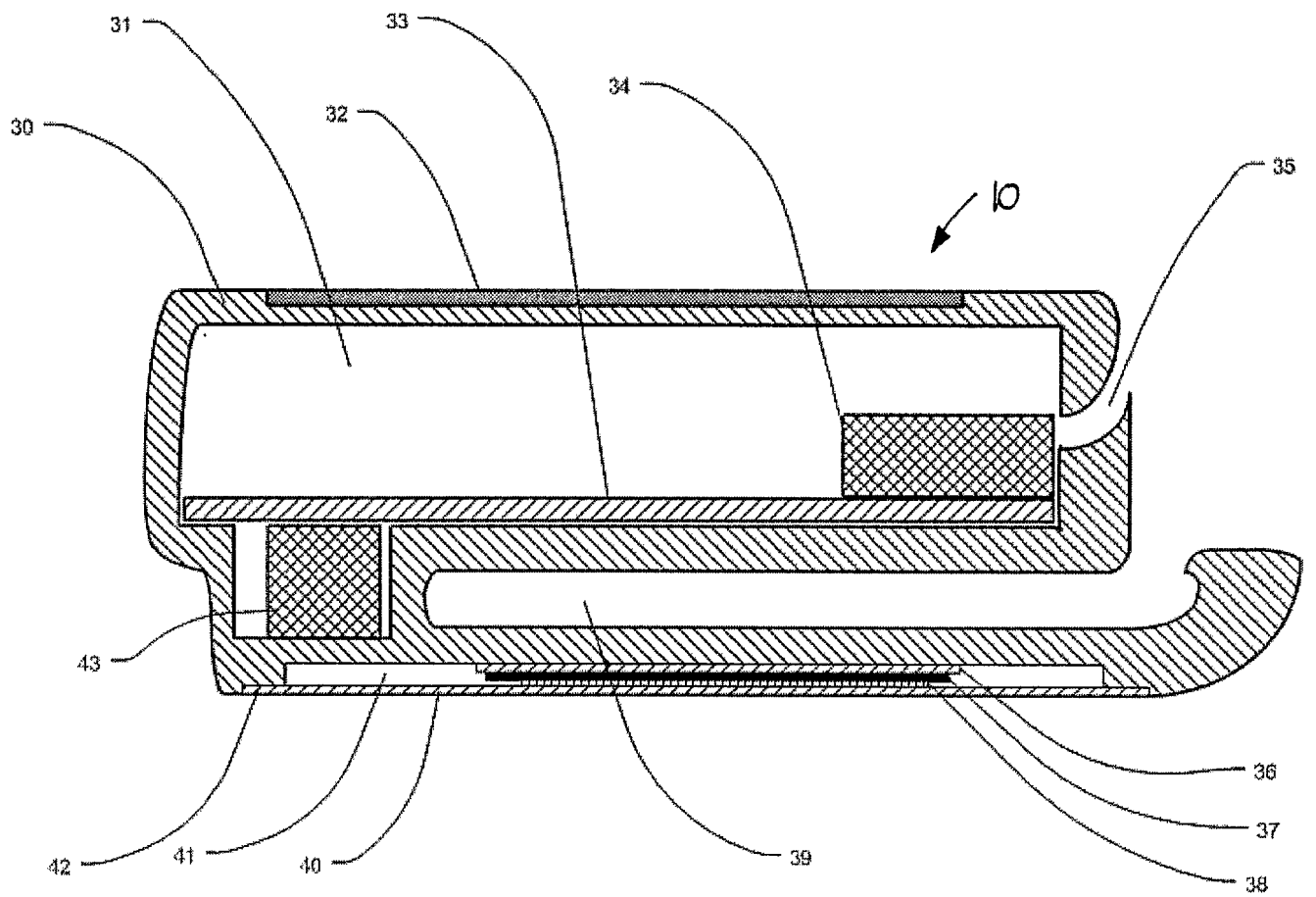

Figure 4

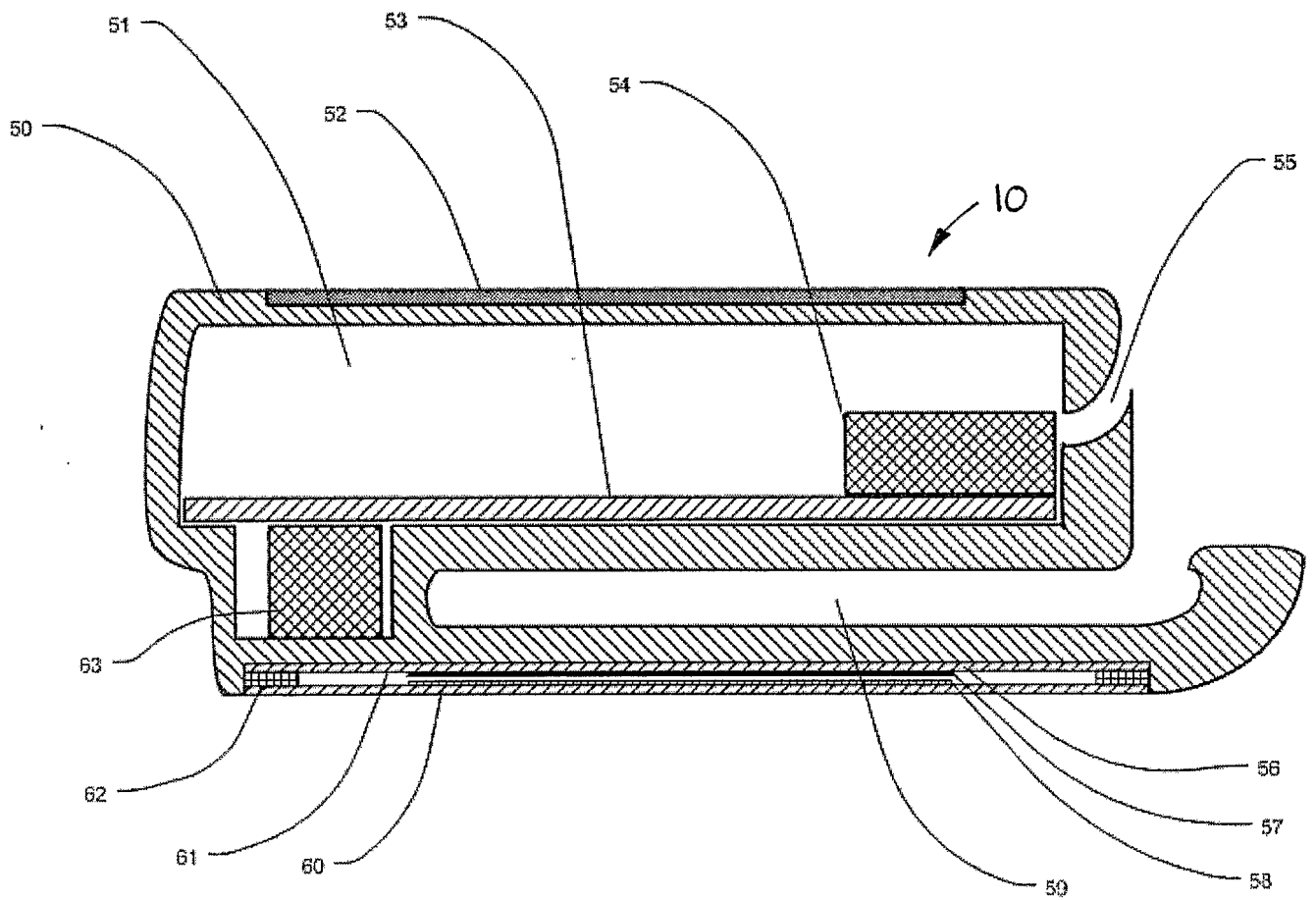

Figure 5

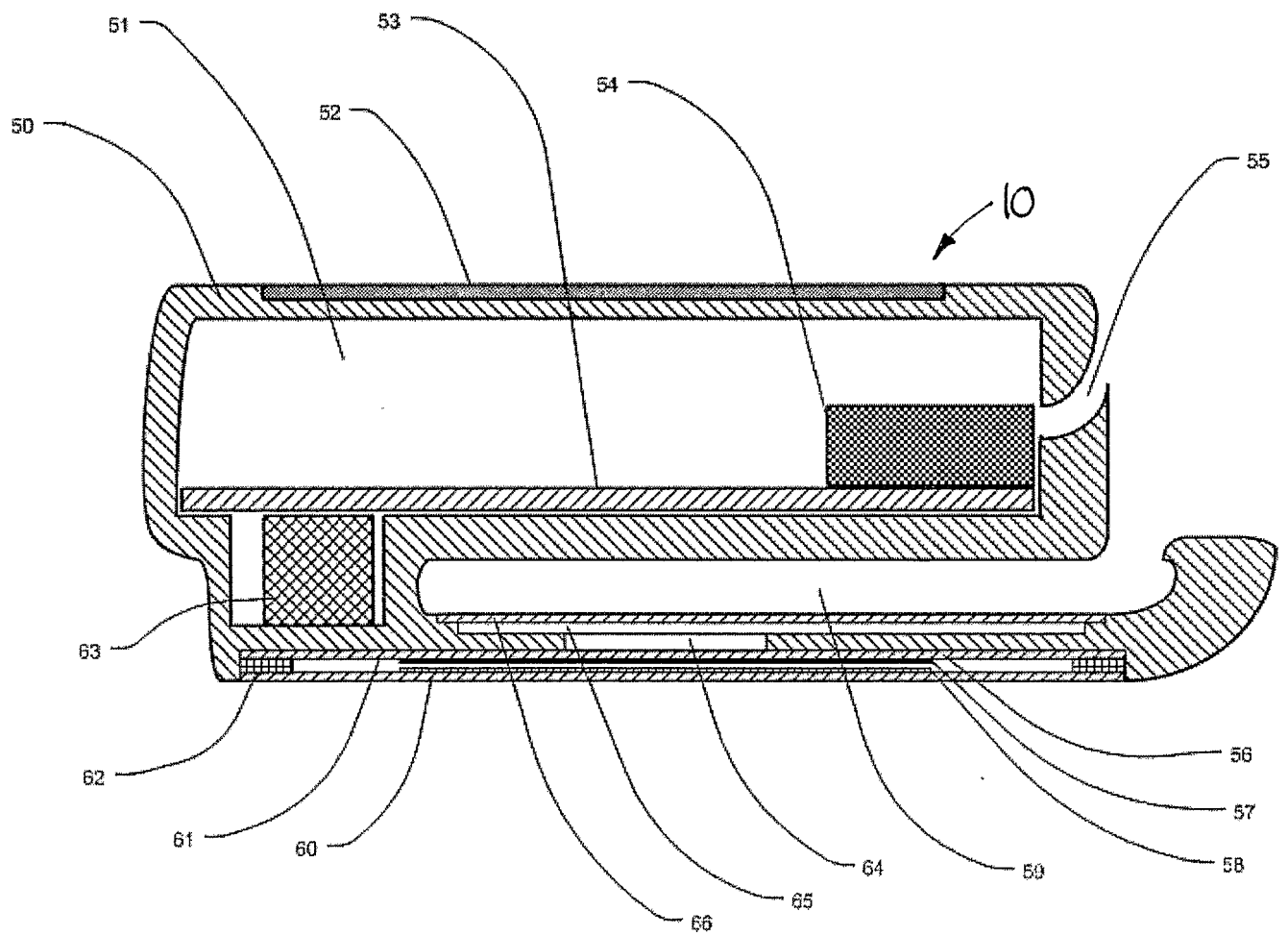

Figure 6

INTERNATIONAL SEARCH REPORT

International Application No
PCT/ZA2004/000091

A. CLASSIFICATION OF SUBJECT MATTER
IPC 7 A61B5/00 A61B5/0205

According to International Patent Classification (IPC) or to both national classification and IPC

B. FIELDS SEARCHED

Minimum documentation searched (classification system followed by classification symbols)
IPC 7 A61B

Documentation searched other than minimum documentation to the extent that such documents are included in the fields searched

Electronic data base consulted during the international search (name of data base and, where practical, search terms used)

EPO-Internal

C. DOCUMENTS CONSIDERED TO BE RELEVANT

Category *	Citation of document, with indication, where appropriate, of the relevant passages	Relevant to claim No.
X	US 2002/124295 A1 (HATCH GUY M ET AL) 12 September 2002 (2002-09-12) paragraphs '0013!, '0014! paragraph '0027! paragraphs '0062! - '0072!	1-3,5-7, 10-13, 20,22, 24-26
Y A		4,16,17, 21 8,9,14, 15,18, 19,23
X	----- US 6 450 168 B1 (NGUYEN KELLIE I) 17 September 2002 (2002-09-17) column 1, line 1 - column 5, line 25 ----- -/--	1,2,6,7, 10-13, 22,26

Further documents are listed in the continuation of box C.

Patent family members are listed in annex.

* Special categories of cited documents :

- *A* document defining the general state of the art which is not considered to be of particular relevance
- *E* earlier document but published on or after the international filing date
- *L* document which may throw doubts on priority claim(s) or which is cited to establish the publication date of another citation or other special reason (as specified)
- *O* document referring to an oral disclosure, use, exhibition or other means
- *P* document published prior to the international filing date but later than the priority date claimed

- *T* later document published after the international filing date or priority date and not in conflict with the application but cited to understand the principle or theory underlying the invention
- *X* document of particular relevance; the claimed invention cannot be considered novel or cannot be considered to involve an inventive step when the document is taken alone
- *Y* document of particular relevance; the claimed invention cannot be considered to involve an inventive step when the document is combined with one or more other such documents, such combination being obvious to a person skilled in the art.
- *&* document member of the same patent family

Date of the actual completion of the international search

24 November 2004

Date of mailing of the international search report

06/12/2004

Name and mailing address of the ISA

European Patent Office, P.B. 5818 Patentlaan 2
NL - 2280 HV Rijswijk
Tel. (+31-70) 340-2040, Tx. 31 651 epo nl,
Fax: (+31-70) 340-3016

Authorized officer

Rivera Pons, C

INTERNATIONAL SEARCH REPORT

International Application No
PCT/ZA2004/000091

C.(Continuation) DOCUMENTS CONSIDERED TO BE RELEVANT		
Category °	Citation of document, with indication, where appropriate, of the relevant passages	Relevant to claim No.
X	<p>US 5 749 365 A (MAGILL ALAN) 12 May 1998 (1998-05-12)</p> <p>column 3, line 23 - column 4, line 2 column 4, lines 42-56 column 5, line 4 - column 6, line 40</p>	1,2,6,7, 10-13, 20,22, 25,26
X	<p>DE 100 05 526 A (KOHR GMBH & CO DR ; KLASCHKA GMBH & CO (DE)) 30 August 2001 (2001-08-30)</p> <p>column 2, line 37 - column 3, line 3 column 3, line 40 - column 4, line 21 column 5, line 56 - column 7, line 24 column 7, line 67 - column 8, line 27 column 9, line 40 - column 10, line 3</p>	1,2,6,7, 10,12, 20,22, 23,25,26
Y	<p>DE 42 14 263 A (GALLASCH EUGEN DIPL ING ; MOSER MAXIMILIAN DR (AU); RAFOLT DIETMAR DIP) 4 November 1993 (1993-11-04) column 6, lines 42-53</p>	16,17
Y	<p>US 2002/008630 A1 (HALLECK MICHAEL D ET AL) 24 January 2002 (2002-01-24) paragraph '0037!; figure 1</p>	4,21

INTERNATIONAL SEARCH REPORT

International application No.
PCT/ZA2004/000091

Box II Observations where certain claims were found unsearchable (Continuation of item 2 of first sheet)

This International Search Report has not been established in respect of certain claims under Article 17(2)(a) for the following reasons:

1. Claims Nos.:
because they relate to subject matter not required to be searched by this Authority, namely:

2. Claims Nos.: 27-29
because they relate to parts of the International Application that do not comply with the prescribed requirements to such an extent that no meaningful International Search can be carried out, specifically;
see FURTHER INFORMATION sheet PCT/ISA/210

3. Claims Nos.:
because they are dependent claims and are not drafted in accordance with the second and third sentences of Rule 6.4(a).

Box III Observations where unity of invention is lacking (Continuation of item 3 of first sheet)

This International Searching Authority found multiple inventions in this international application, as follows:

1. As all required additional search fees were timely paid by the applicant, this International Search Report covers all searchable claims.

2. As all searchable claims could be searched without effort justifying an additional fee, this Authority did not invite payment of any additional fee.

3. As only some of the required additional search fees were timely paid by the applicant, this International Search Report covers only those claims for which fees were paid, specifically claims Nos.:

4. No required additional search fees were timely paid by the applicant. Consequently, this International Search Report is restricted to the invention first mentioned in the claims; it is covered by claims Nos.:

Remark on Protest

- The additional search fees were accompanied by the applicant's protest.
- No protest accompanied the payment of additional search fees.

Continuation of Box II.2

Claims Nos.: 27-29

The subject-matter matter of claims 27-29 has not been searched because of lack of clarity of the definition and the scope of protection of these claims.

The applicant's attention is drawn to the fact that claims relating to inventions in respect of which no international search report has been established need not be the subject of an international preliminary examination (Rule 66.1(e) PCT). The applicant is advised that the EPO policy when acting as an International Preliminary Examining Authority is normally not to carry out a preliminary examination on matter which has not been searched. This is the case irrespective of whether or not the claims are amended following receipt of the search report or during any Chapter II procedure. If the application proceeds into the regional phase before the EPO, the applicant is reminded that a search may be carried out during examination before the EPO (see EPO Guideline C-VI, 8.5), should the problems which led to the Article 17(2) declaration be overcome.

INTERNATIONAL SEARCH REPORT

Information on patent family members

International Application No
PCT/ZA2004/000091

Patent document cited in search report	Publication date	Patent family member(s)	Publication date
US 2002124295	A1	12-09-2002	NONE
US 6450168	B1	17-09-2002	WO 02082976 A2 24-10-2002
US 5749365	A	12-05-1998	CA 2123126 A1 13-05-1993 EP 0611288 A1 24-08-1994 WO 9308734 A1 13-05-1993 GB 2261290 A ,B 12-05-1993 JP 7500748 T 26-01-1995
DE 10005526	A	30-08-2001	DE 10005526 A1 30-08-2001
DE 4214263	A	04-11-1993	DE 4214263 A1 04-11-1993
US 2002008630	A1	24-01-2002	US 6307481 B1 23-10-2001 WO 02061704 A1 08-08-2002 AU 7586700 A 17-04-2001 BR 0014039 A 30-07-2002 CA 2385062 A1 22-03-2001 EP 1212736 A1 12-06-2002 JP 2003509781 T 11-03-2003 MX PA02002805 A 30-08-2002 TW 494368 B 11-07-2002 WO 0120571 A1 22-03-2001 US 2003088160 A1 08-05-2003 US 2003072458 A1 17-04-2003 US 2003146844 A1 07-08-2003 US 6147618 A 14-11-2000 US 6415033 B1 02-07-2002 US 6377185 B1 23-04-2002 US 2001000431 A1 26-04-2001 US 2001048368 A1 06-12-2001 WO 02061705 A1 08-08-2002 US 2002118121 A1 29-08-2002

专利名称(译)	用于监测人类状况的装置		
公开(公告)号	EP1653850A1	公开(公告)日	2006-05-10
申请号	EP2004785430	申请日	2004-08-04
[标]申请(专利权)人(译)	彼得森JOHANNES德克勒克		
申请(专利权)人(译)	彼得森, JOHANNES德克勒克		
当前申请(专利权)人(译)	彼得森, JOHANNES德克勒克		
[标]发明人	PIETERSEN JOHANNES DE KLERK		
发明人	PIETERSEN, JOHANNES DE KLERK		
IPC分类号	A61B5/00 A61B5/0205 A61F13/15		
CPC分类号	A61B5/02055 A61B5/0002 A61B5/01 A61B5/0205 A61B5/6804 A61F13/84		
优先权	200308285 2003-10-24 ZA 200306138 2003-08-08 ZA 200300949 2003-08-04 ZA		
其他公开文献	EP1653850B1		
外部链接	Espacenet		

摘要(译)

一种用于连续监测与人的健康或舒适度相关的一个或多个指示器的装置12包括一个或多个用于测量一个或多个所需指示器的值的传感装置和一个在测量值高于时传达警报信号的通信装置13或者低于预定值或值范围的范围,其中装置10适于附接到人12的衣服14。