



## INTERNATIONAL APPLICATION PUBLISHED UNDER THE PATENT COOPERATION TREATY (PCT)

<b>(51) International Patent Classification <sup>7</sup> :</b>  <b>A61B</b>	<b>A2</b>	<b>(11) International Publication Number:</b> <b>WO 00/67633</b>  <b>(43) International Publication Date:</b> 16 November 2000 (16.11.00)
<b>(21) International Application Number:</b> PCT/US00/12014 <b>(22) International Filing Date:</b> 3 May 2000 (03.05.00)  <b>(30) Priority Data:</b> 09/306,907                      7 May 1999 (07.05.99)                      US  <b>(71)(72) Applicant and Inventor:</b> TELLER, David [US/US]; Sun- nyside Ave., Mill Valley, CA 94941 (US).	<b>(81) Designated States:</b> AT, BR, CA, DE, ES, GB, IL, MX, NO, PL, PT, SE, TR, US, European patent (AT, BE, CH, CY, DE, DK, ES, FI, FR, GB, GR, IE, IT, LU, MC, NL, PT, SE).  <b>Published</b> <i>Without international search report and to be republished  upon receipt of that report.</i>	
<b>(54) Title:</b> METHOD AND APPARATUS FOR HEALTH SIGNS MONITORING		
<b>(57) Abstract</b>  A system for monitoring health signs of an individual detects at least one health sign characteristic of the individual with a sensor unit that is located proximate the individual, produces a health signal from the sensor that indicates at least one health sign of the individual, communicates the health signal from the individual to a receiving apparatus over a wireless connection, provides the communicated health signal to a network, and processes the provided signal at a destination node of the network to indicate if an emergency condition exists. The system sends the health signal to a receiving apparatus over a wireless transmission link and to a computer network, and processes the signal at a destination node to indicate if an emergency condition exists. The components associated with the wireless transmission link are sufficiently small and light weight that the components can be clipped to patient garment or on a harness, which can be worn by the patient without undue discomfort.		

*FOR THE PURPOSES OF INFORMATION ONLY*

Codes used to identify States party to the PCT on the front pages of pamphlets publishing international applications under the PCT.

AL	Albania	ES	Spain	LS	Lesotho	SI	Slovenia
AM	Armenia	FI	Finland	LT	Lithuania	SK	Slovakia
AT	Austria	FR	France	LU	Luxembourg	SN	Senegal
AU	Australia	GA	Gabon	LV	Latvia	SZ	Swaziland
AZ	Azerbaijan	GB	United Kingdom	MC	Monaco	TD	Chad
BA	Bosnia and Herzegovina	GE	Georgia	MD	Republic of Moldova	TG	Togo
BB	Barbados	GH	Ghana	MG	Madagascar	TJ	Tajikistan
BE	Belgium	GN	Guinea	MK	The former Yugoslav Republic of Macedonia	TM	Turkmenistan
BF	Burkina Faso	GR	Greece	ML	Mali	TR	Turkey
BG	Bulgaria	HU	Hungary	MN	Mongolia	TT	Trinidad and Tobago
BJ	Benin	IE	Ireland	MR	Mauritania	UA	Ukraine
BR	Brazil	IL	Israel	MW	Malawi	UG	Uganda
BY	Belarus	IS	Iceland	MX	Mexico	US	United States of America
CA	Canada	IT	Italy	NE	Niger	UZ	Uzbekistan
CF	Central African Republic	JP	Japan	NL	Netherlands	VN	Viet Nam
CG	Congo	KE	Kenya	NO	Norway	YU	Yugoslavia
CH	Switzerland	KG	Kyrgyzstan	NZ	New Zealand	ZW	Zimbabwe
CI	Côte d'Ivoire	KP	Democratic People's Republic of Korea	PL	Poland		
CM	Cameroon	KR	Republic of Korea	PT	Portugal		
CN	China	KZ	Kazakstan	RO	Romania		
CU	Cuba	LC	Saint Lucia	RU	Russian Federation		
CZ	Czech Republic	LI	Liechtenstein	SD	Sudan		
DE	Germany	LK	Sri Lanka	SE	Sweden		
DK	Denmark	LR	Liberia	SG	Singapore		
EE	Estonia						

## METHOD AND APPARATUS FOR HEALTH SIGNS MONITORING

### CROSS-REFERENCE TO RELATED APPLICATION

5           This application is a continuation-in-part of U.S. Patent Application No. 08/940,349 filed September 30, 1997.

### BACKGROUND OF THE INVENTION

#### 10           1. Field of the Invention

The present invention relates generally to monitoring the health of an individual and, more particularly, to remote monitoring of health signs such as temperature and heart rate.

#### 15           2. Description of the Related Art

It is known in a hospital setting to continuously monitor various health signs of a patient, such as temperature and heart rate, by utilizing relatively complicated and expensive equipment. For example, equipment routinely employed in hospital intensive care units includes temperature sensors  
20           that are thermally coupled to the skin of a patient with adhesive. One or more wires run from the patient to a display monitoring device. Such equipment may be more intrusive than is desired, as it can be annoying for the patient to deal with the sensor wires that extend from the hospital bed, but the need for continuous monitoring and rapid reaction to changes in patient condition make the intrusion necessary. This is particularly the case in a hospital setting, where changes in health signs  
25           such as temperature and heart rate can be critical. Nevertheless, the monitoring equipment can be sufficiently intrusive that the patient's rest can be disturbed. It would be advantageous if the monitoring system employed in the hospital setting was less intrusive to the patient's comfort.

-2-

In addition, monitoring equipment that transmits data by means of radio frequency (RF) signals can cause interference among multiple equipment units located near each other, as in a hospital environment. In addition, monitoring equipment should be readily usable from patient to patient, so that resources can be deployed exactly where needed and used by different patients.

5 There are situations in which continuous monitoring of vital health signs in a home setting may be desirable. The hospital-grade equipment does not represent a viable alternative for a home environment, as the equipment is usually quite expensive. Moreover, the hospital equipment is typically much more intrusive than is necessary in the home setting, where changes in condition are typically not so critical that the intrusiveness of hospital equipment is justified. In addition, hospital  
10 equipment typically includes complicated connections to warning displays or other monitoring equipment that do not exist in the home environment. The general populace is quite unprepared to operate such sophisticated equipment. Moreover, most homes lack any reliable patient assistance, such as an in-home caregiver, who could respond to any warning signals produced by such sophisticated equipment.

15 Other equipment typically used in the home environment is less intrusive and more simple to use, but is not generally suitable to the continuous monitoring of health signs. For example, thermometers are readily available for home use, but any thermometer reading must be manually taken each time an individual's temperature is needed. The same is true for heart rate, blood pressure, and other health-related information. As noted above, the continuous presence of health  
20 care assistance in the home cannot be reliably depended upon for performing such tasks. In addition, it can be difficult to properly interpret changes in health signs, or even be aware of changes over time that might indicate some form of health trouble for an individual. Finally, some monitoring systems are integrated with garments, that are not easily transferred as children grow or circumstances change.

25 From the discussion above, it should be apparent that there is a need for convenient and minimally intrusive monitoring of health signs, with dependable monitoring of the health signs for any indication of trouble. The present invention fulfills these needs.

-3-

**SUMMARY OF THE INVENTION**

In accordance with the present invention, a system for monitoring health signs of an individual detects at least one health sign characteristic of the individual with a health signs sensor unit that is located proximate the individual, produces a health signal from the health signs sensor that indicates at least one health sign of the individual, communicates the health signal from the individual to a receiving apparatus over a wireless connection, provides the communicated health signal to a network, and processes the provided signal at a destination node of the network to indicate if an emergency condition exists. The system preferably sends the health signal to a receiving apparatus over a wireless transmission link and to a computer network, and processes the signal to indicate if an emergency condition exists. The components associated with the wireless transmission link are sufficiently small and light weight that the components can be clipped to a patient garment or on a harness, which can be worn by the patient without undue discomfort. Unlike systems that connect a patient with wires to a monitor that then transmits information in a wireless link, the present invention needs no wired connection to any monitoring apparatus. In this way, health signs of an individual are dependably monitored in a relatively convenient and minimally intrusive manner for any indication of trouble. This monitoring technique is readily applied in both the hospital environment and in the home setting.

In one aspect of the invention, the sensor unit can process the health signs signal before transmitting to the receiving apparatus so as to reduce the amount of data that must be transmitted over the wireless link. The remote node of the computer network can comprise a multimedia server, such as a conventional Personal Computer or similar device with audio and video capabilities. If desired, the computer network can comprise a network such as the Internet, and the multimedia server can be placed in a remote location. The multimedia server can then communicate with other remote locations, such as health care monitoring facilities, to transmit the data generated by the health signs sensor, or can control a device or appliance.

-4-

In another aspect of the invention, each sensor unit is encoded with a unique identification number that is communicated whenever it transmits a signal, and the receiving apparatus registers the first identification number it receives when power is first applied to the receiving apparatus. The receiving apparatus will thereafter ignore health signs messages it detects from sensor units other than the one with which it is registered. This provides a convenient way to ensure that multiple sensor units can be used in close proximity without interference or interruptions in service.

Other features and advantages of the present invention should be apparent from the following description of the preferred embodiment, which illustrates, by way of example, the principles of the invention.

#### BRIEF DESCRIPTION OF THE DRAWINGS

Figure 1 is a schematic diagram of a health signs monitoring system constructed in accordance with the present invention.

Figure 2 is a representation of the sensor unit illustrated in Figure 1.

Figure 3 is a block diagram of the sensor unit illustrated in Figure 2.

Figure 4 is a block diagram of the display unit illustrated in Figure 1.

Figure 5 is a block diagram of the computer port unit illustrated in Figure 1.

Figure 6 is a block diagram of the computer illustrated in Figure 1.

Figure 7 is a block diagram of the network interface unit illustrated in Figure 1.

Figure 8 is a flow diagram showing the operating steps performed by the health signs monitoring system of Figure 1.

Figure 9 is a flow diagram that shows the operating steps executed in performing system initialization and registration of the transmitting unit with the receiving apparatus.

Figure 10 is a schematic diagram of a harness embodiment of the health signs monitoring system constructed in accordance with the present invention.

Figure 11 is a perspective view of the monitoring harness illustrated in Figure 1.

-5-

## DESCRIPTION OF THE PREFERRED EMBODIMENTS

Figure 1 illustrates a health signs monitoring system 100 constructed in accordance with the present invention. The system 100 includes a sensor unit 102 that is worn by a patient 104 whose health signs are to be monitored. The health signs may include a wide variety of patient characteristics that indicate the health of an individual, such as temperature, heart rate, blood pressure, respiration, blood oxygen, moisture, muscle response, and patient body position. The sensor unit 102 is sufficiently small and light that it can be clipped to a garment 106 worn by the patient. In this way, the sensor unit will minimally intrude on patient comfort and mobility. Sensors extend from the sensor unit to the skin of the patient, where they are fastened with tape or adhesive. The health signs information from the sensor unit 102 is sent by means of a wireless transmission 108 to a receiving apparatus 110. The receiving apparatus receives the health signs information and processes the information so that a health care provider or other assistance can determine if a response to the patient condition is required. In this way, the system 100 provides continuous health signs monitoring with minimal intrusion to the patient's lifestyle.

The wireless transmission 108 can involve a radio frequency (RF) signal or other wireless technologies, such as the "Personal Area Network" technique available from International Business Machines Corporation (IBM Corporation). The wireless transmission eliminates the hard-wired connection from the sensor unit to a base station receiver and frees the patient from negotiating bedside wires that tend to get entangled. In the case of RF technology, the sensor unit 102 includes a small transmitter.

The receiving apparatus 110 can comprise any one of a number of alternative receiving devices, including, for example, a display unit 112, a computer port unit 114, or a network interface unit 116. Any one of these devices can serve as a means to communicate health signs information to a health care provider or other assistance and to determine if an emergency condition exists. In

-6-

addition, these units 112, 114, 116 can be integrated into a single receiving apparatus to provide a multi-function receiving apparatus, if desired.

As described further below, a display unit 112 with no other functionality communicates the health signs information to a health care provider, such as a nurse or other assistant, by means of a display panel. The computer port unit 114 communicates the health signs information to a computer 118, such as from a data port 119 through an appropriate cable 120 to a serial port or parallel port connection 122 at the computer. The computer 118 includes a network interface 124 to connect the computer with a network link 126 to a multimedia server (MMS) 128. The MMS may comprise a server on a wide area network, such as the Internet, or on a local intranet. The network link 126 may be, for example, a computer connection to a telephone line, optic cable, high-speed wire, or other communications link. The network interface unit 116 communicates the health signs information over a network link 130, such as an Internet connection, to the MMS 128. The MMS may be connected to one or more response devices 132, including a pager, telephone, facsimile machine, computer, or a device or appliance located at a health care provider or in the household of the patient being monitored.

### Sensor Unit

Figure 2 is a perspective view of the sensor unit 102 illustrated in Figure 1, and shows that the sensor unit comprises a small transmitting card 202 from which extends a connecting wire 204 that ends in a sensor pad 206. The sensor pad is attached to a location on the patient that will permit optimal placement for sensing the patient health signs. The location depends on the design of the sensor and the health signs being measured. The sensor pad 206 is typically attached to the patient's skin using removable adhesives that will be known to those skilled in the art. Alternatively, the sensor pad may be attached with cuffs or bands that ensure optimal placement. For example, the sensor pad may comprise a cuff that wraps around an arm or wrist to provide a variety of health signs signals, such as blood pressure, hear rate, respiration rate, oximetry, and body temperature. The

-7-

sensor pad also may comprise a saliva analysis pad lodged in the patient's mouth. As described further below, a communications port 212 is optionally provided to permit interfacing the transmitting card 210 with one of the receiving apparatus 110 (Figure 1), if desired. A battery life indicator 214 is provided along the top edge of the card to indicate battery lifetime, as described further below.

The transmitting card 202 is preferably no larger than a typical pager or matchbook. The transmitting card is attached to a garment worn by the patient with a clip 208 that holds the garment between the clip and the back side 210 of the transmitting card. The small size of the transmitting card and the clip will permit attachment at the collar of a shirt, for example, so as to minimize intrusion into the patient's comfort and freedom of movement. The connecting wire 204 can be sized to provide desired flexibility in the placement of the sensor pad 206. A wire of approximately six inches in length has been found sufficient for optimal placement of the sensor pad with the transmitting card worn at the patient's collar. If desired, the transmitting card 202 may have a clip or other attachment device that produces an alarm signal if the transmitting card is removed from the garment.

Figure 3 is a block diagram of the sensor unit 102, showing the primary functional components. A control integrated circuit (IC) 302 receives the health signs sensor signal from the sensor pad connecting wire 204. The control IC performs any processing or signal conditioning necessary to process the signal and produce data before providing the health signs data to a transmitter 306. The transmitter continuously generates a wireless signal by which the health signs data is provided to any one of the receiving apparatus 110 shown in Figure 1. The wireless transmitter can make use of conventional radio frequency (RF) transmission techniques, which are well-known to those skilled in the art.

Alternatively, the transmitter can make use of so-called "Personal Area Network" technology that utilizes low-voltage of the human body to electrically transfer information from the body of an individual through physical contact or proximity with a receiving body. The Personal Area Network technology eliminates the need for electromagnetic over large distances. The health signs

-8-

monitoring system with Personal Area Network technology thereby is not affected by most RF energy, and will not interfere with the operation of RF-sensitive equipment. The transmission distance of the Personal Area Network technology is somewhat limited, so if the Personal Area Network technology is used with the sensor unit, then a patient covering such as a blanket may act as a receiving unit or antenna for the Personal Area Network transmitter. As an alternative to wireless transmission of the health signs data to a receiving apparatus, a wired link can be provided through the communications port 212, which is connected to the control IC 302. The communications port 212 receives a multi-pin connector (not shown) for a wire cable that is coupled to the receiving apparatus, and thereby permits the control IC to transmit the health signs data over a wired link.

Power for operation of the sensor unit 102 is provided by a battery 308 that is preferably small and with long service life. Typical batteries suitable for this purpose include camera batteries and watch batteries. Because of the health monitoring function of the system 100, it is critical that the sensor unit have a able and ready source of electrical power. Typically, such assurance would be provided by battery monitoring circuitry, with a battery charge display. A battery monitoring feature of the invention eliminates the need for battery charge circuitry to detect and display remaining battery life.

In accordance with the invention, the system 100 determines remaining battery life by programming executed by the control IC 302 that counts the number of signal transmissions from the sensor unit 102 to the receiving apparatus 110 (Figure 1). It should be noted that, in normal operation, the sensor unit continuously transmits health signs signals to the receiving apparatus. With the frequency of health signs transmission known (for example, one transmission every sixty seconds), and with the message length of each transmission known, it is relatively simple to determine the expected number of signal transmissions in a battery lifetime. The control IC keeps this lifetime count, and decrements the expected number of message transmissions in the remaining life of the battery. As soon as the lifetime count of remaining transmissions reaches a predetermined point, such as at zero transmissions left in the count, the battery is declared dead. The battery

-9-

lifetime indicator 214 can be, for example, a bright LED that glows steadily so long as time remains in the battery lifetime count. Once the lifetime count has been reached, the control IC 302 extinguishes the indicator light, even if there is still sufficient battery power to light the LED. In this way, battery lifetime can be indicated without relatively expensive battery charge circuitry.

5

### Display Unit

10

As shown in Figure 1, one of the receiving apparatus 110 that may receive the health signs signal from the sensor unit 102 is a display unit 112. Figure 4 shows details of the display unit construction.

15

20

Figure 4 shows that the display unit 112 includes a receiver 402 that is adapted to receive transmissions of the type sent by the transmitter 306 (see Figure 3). For example, if the transmitter produces radio frequency (RF) transmissions, then the receiver 402 can be a conventional RF receiver. The receiving unit 108 also includes a control panel 404 and a status display 406, which provide a control interface through which a user provides commands and views system operating indications. The status display 406 can be used to display the current health signs information, such as current patient temperature, and if desired can also display other useful information, such as clock time or desired health signs signal value. If desired, the display unit can store all display data in memory, including clock time of recording. In addition, the status display can be made to show selected messages upon the occurrence of particular health signs signals, such as a treatment for the emergency condition. For example, if a high patient temperature is indicated, then the displayed message might comprise an advertisement for a fever relief medicine. Warning messages also may be displayed.

25

The display unit 112 of Figure 4 is designed to be easily transported to any room in which it is needed and to be of minimum size. As a result, the display unit operates under control of a control IC chip 408. Thus, the display unit does not require a complicated operating system or other

-10-

peripheral resources that would increase the size and power requirements of the display unit. This ensures maximum transportability and flexibility of the system, and reduces costs.

5 The display unit 112 continuously receives health signs data from the sensor unit 102, but may store that data for processing. That is, the display unit control IC chip 408 can be programmed so that health signs data is stored in memory that is part of the chip and then is processed at regular intervals. As an example, the IC chip might be programmed so that health signs information sent to the display unit is stored in the control IC chip memory every ten minutes, to provide a long-term record of health signs information that can be analyzed to detect trends over time that might not be apparent over a more frequent recording schedule, or that might be tedious to review. This can accommodate analysis of temperature data, which might be affected by circadian rhythms or other factors. Thus, a temperature fluctuation that might otherwise indicate an alarm will instead be determined to be a result of normal circadian fluctuation. The data recording feature also provides data storage that is not readily accessible by unauthorized persons.

15 As an alternative to using a wireless transmission means such as RF signals, the receiver 402 can make use of the so-called "Personal Area Network" technology that utilizes low-voltage of the human body to electrically transfer information from the body of an individual through physical contact or proximity with a receiving body. The transmission distance of the Personal Area Network technology is somewhat limited, so if the Personal Area Network technology is used with the sensor unit, then a patient covering such as a blanket may act as a receiving unit for the Personal Area Network transmitter.

20 In addition, as an alternative to wireless reception of the health signs data, a wired link can be provided through the port 410, which is connected to the communications port 212 of the sensor unit 102 (Figure 2). Internally to the display unit 112 of Figure 4, the port 410 provides its signal to the control IC chip 408, and thereby permits the control IC chip to receive the health signs data over a wired link. Finally, the receiver 402 can be configured as a receiver for radio frequency identification (RFID) technology from Texas Instruments Incorporated, called "TIRIS". Those skilled in the art will recognize that TIRIS technology is currently deployed in oil company service

-11-

station payment systems, which include a very low power transmitter that is passed adjacent a compatible receiving sensor to download identification data for payment. In the health monitoring system described herein, such technology can be used to download identification information for health care personnel, such as nurses. This information can be incorporated into the health signs information that is transmitted to a receiving apparatus. In addition, the TIRIS technology can be used to force a particular receiving apparatus identification code into the health signs information, as described further below in connection with the system initialization processing of Figure 9.

If desired, the display unit 112 can incorporate an environmental sensor 412 that provides an ambient environmental signal with which to perform attenuation and adjudication of the health signs signal from the sensor unit 102. For example, the environmental sensor can comprise a microphone to subtract ambient noise from a sensor unit microphone signal, or can comprise a temperature probe to compensate the sensor unit signal for ambient temperature extremes that might otherwise provide an inaccurate or misleading signal.

#### Computer Port Unit

Another one of the Figure 1 receiving apparatus 110 that may receive the health signs signal from the sensor unit 102 is a computer port unit 114. Figure 5 shows details of the computer port unit construction.

Figure 5 shows that the computer port unit 114 includes a receiver 502 that is adapted to receive transmissions of the type sent by the transmitter 306 (see Figure 3). The computer port unit operates under control of a control IC chip 504. Thus, the computer port unit does not require a complicated operating system or other peripheral resources that would increase the size and power requirements of the display unit. This ensures maximum transportability and flexibility of the system, and also reduces cost of manufacture.

The computer port unit control IC chip 504 can be programmed so that health signs data is stored at regular intervals in memory that is part of the chip, such as every ten minutes, to provide

-12-

a long-term record of health signs information that can be analyzed to detect trends over time that might not be apparent over a more frequent recording schedule, or that might be tedious to review. The control IC chip can be programmed to download the stored data at a predetermined time or recording interval, in concert with the recording schedule or at a different interval, or the chip can be programmed to respond to a predetermined signal that initiates download. This feature also provides data storage that is not readily accessible by unauthorized persons.

As with the display unit, the health signs transmissions received by the computer port unit 114 may comprise RF transmissions, in which case the receiver 502 is a conventional RF receiver, or may comprise the "Personal Area Network" technology that utilizes low-voltage of the human body to electrically transfer information from the body of an individual through physical contact or proximity with a receiving body. The transmission distance of the Personal Area Network technology is somewhat limited, so if the Personal Area Network technology is used with the sensor unit, then a patient covering such as a blanket may act as a receiving unit for the Personal Area Network transmitter. As an alternative to wireless reception of the health signs data, a wired link to the sensor unit can be provided through a port 506, which is connected to the communications port 212 of the sensor unit 102 (Figure 2). Internally to the computer port unit 114 of Figure 5, the port 506 provides its signal to the control IC chip 504, and thereby permits the control IC chip to receive the health signs data over a wired link.

The computer port unit 114 also includes a control panel 508 and a status display 510, which provide a control interface through which a user provides commands and views system operating indications. The status display 508 can be an alphanumeric display to show the current health signs information, such as current patient temperature, and if desired can also show other useful information, such as clock time or desired health signs signal value. In addition, the status display can be made to show selected messages upon the occurrence of particular health signs signals, such as targeted advertising or warning messages, similar to those provided by the display unit 112.

In a similar fashion to the display unit 112, the computer port unit 114 can incorporate an environmental sensor 512 that provides an ambient environmental signal with which to perform

-13-

attenuation and adjudication of the health signs signal from the sensor unit 102, such as a microphone to subtract ambient noise or a temperature probe to compensate for ambient temperature extremes. In this way, the computer port unit 114 can be characterized as a receiving apparatus 110 that integrates the display unit with additional communications capability to interface with a computer 118. Moreover, the system can consider a combination of multiple health signs and ambient signals in determining if an emergency condition exists.

As shown in Figure 1, the computer port unit 114 interfaces to the computer 118 through a cable 120 that runs from a computer data port 119 to a serial port or parallel port connection 122 at the computer. Alternatively, the cable 120 can comprise a modem line or other analog or digital means of communicating with the computer. For example, the programming of the IC chip 504 can incorporate modem functionality and automatically call and obtain a modem line to the computer (if so connected) at regular intervals for transfer of health signs data. Those skilled in the art will recognize that such functionality is easily provided with the IC chip. The computer 118 is illustrated in greater detail in Figure 6.

Figure 6 shows that the computer 118 operates under control of a central processing unit (CPU) 602, such as a "Pentium" microprocessor manufactured by Intel Corporation. The CPU controls operation of the serial/parallel port 122 to communicate with the computer port unit 114 and controls operation of the computer network interface 124 to communicate with the MMS 128. Thus, the health signs data transmitted from the sensor unit 102 to the computer port unit 114 is sent to the computer 118 over the cable 120, and then to the MMS 128.

A user controls operation of the computer 118 through a keyboard 608 and display 610, which provide a means of communicating information and receiving commands from the user. The display may comprise, for example, a typical computer display screen such as a video monitor or flat panel display. The computer 118 also includes an audio player 612, which typically includes what is commonly referred to as a sound card, with appropriate sound drivers and loudspeakers. The audio player permits audible warnings to be played, for example, and can optionally include a sound microphone to receive audible requests from a user or from a patient.

-14-

The operating system and applications that are executed by the computer 118 are stored in memory 614. The memory may comprise a mixture of semiconductor memory and other storage media in which data, commands, and program instructions can be stored. The operating system of the computer may comprise, for example, the Windows 95/98/NT products from Microsoft Corporation or the MacIntosh operating system by Apple Computer Corporation. The executed memory instructions of the computer 118 implement the proper processing for communication between the computer port unit 114 and the MMS 128. The computer also includes a storage media reader 616, such as a hard disk drive or a removable media disk drive. If the storage media reader is a removable media disk drive, then it accepts external storage media 618 such as a floppy disk or an optical (CD or DVD) disk. Such media provide a convenient means of receiving data or new programming. If the storage media reader also has write capabilities, then it can also provide a convenient means of downloading data or programming to other computers.

From the computer 118, health signs information can be communicated to the MMS unit 128 shown in Figure 1. As noted above, the MMS may comprise a server on a wide area network, such as the Internet, or on a local intranet. The MMS may have a construction similar to that of the computer 118, so that the MMS preferably includes at least a CPU, keyboard, display, memory, serial/parallel port, and network interface. The construction details of the MMS are therefore similar to those of the computer 118. Additionally, the MMS includes whatever interfaces are necessary to support communication with the response devices 132 (Figure 1), such as a pager, telephone, facsimile machine, computer, or a device or appliance located at a health care provider or in the household of the patient being monitored.

#### Network Interface Unit

The last receiving apparatus shown in Figure 1 is the network interface unit 116, which receives signals from the sensor unit 102 and provides the health signs data to the MMS 128. Figure 7 shows construction details of the network interface unit.

-15-

Figure 7 shows that the network interface unit 116 includes a receiver 702 that is adapted to receive transmissions of the type sent by the transmitter 306 (see Figure 3). A network interface 703 permits the unit 116 to provide health signs data to the network connection 130. The network interface unit 116 operates under control of a control IC chip 704. Thus, the network interface unit  
5 does not require a complicated operating system or other peripheral resources that would increase the size and power requirements of the unit. This ensures maximum transportability and flexibility of the system, and also reduces cost of manufacture.

The network interface unit control IC chip 704 can be programmed so that health signs data is stored at regular intervals in memory that is part of the chip, such as every ten minutes, to provide  
10 a long-term record of health signs information that can be analyzed to detect trends over time that might not be apparent over a more frequent recording schedule, or that might be tedious to review. The control IC chip can be programmed to download the stored data at a predetermined time or recording interval, or the chip can be programmed to respond to a predetermined signal from the receiving unit that initiates download. This also provides data storage that is not readily accessible  
15 by unauthorized persons. As with the display unit and the computer port unit, the network interface unit can be programmed to automatically obtain a network connection and transfer health signs data at regular intervals.

As with the display unit, the transmissions received by the network interface unit 116 may comprise RF transmissions, in which case the receiver 702 is a conventional RF receiver, or may  
20 comprise the "Personal Area Network" technology that utilizes low-voltage of the human body to electrically transfer information from the body of an individual through physical contact or proximity with a receiving body. As noted above, the transmission distance of the Personal Area Network technology is somewhat limited, so if the Personal Area Network technology is used with the sensor unit, then a patient covering such as a blanket may act as a receiving unit for the Personal  
25 Area Network transmitter. As an alternative to wireless reception of the health signs data, a wired link to the sensor unit can be provided through a port 706, which is connected to the communications port 212 of the sensor unit 102 (Figure 2). Internally to the network interface unit 116, the port 706

-16-

provides its signal to the control IC chip 704, and thereby permits the control IC chip to receive the health signs data over a wired link.

The network interface unit 116 also includes a control panel 708 and a status display 710, which provide a control interface through which a user provides commands and views system operating indications. The status display 708 can be an alphanumeric display to show the current health signs information, such as current patient temperature, and if desired can also show other useful information, such as clock time or desired health signs signal value. In addition, the status display can be made to show selected messages upon the occurrence of particular health signs signals, such as targeted advertising or warning messages. If desired, the network interface unit 116 can incorporate an environmental sensor 712 that provides an ambient environmental signal with which to perform attenuation and adjudication of the health signs signal from the sensor unit 102. For example, the environmental sensor can comprise a microphone to subtract ambient noise from a sensor unit microphone signal, or can comprise a temperature probe to compensate the sensor unit signal for ambient temperature extremes that might otherwise provide an inaccurate or misleading signal.

### Operation of the Health Signs Monitoring System

Figure 8 is a flow diagram that shows the steps performed during operation of the health signs monitoring system constructed in accordance with the present invention. In the first step, represented by the flow diagram box numbered 802, the system is initialized as electrical power is applied. As described further below, initialization involves one or more sensor units making their presence known to a receiving unit. It should be understood that a health signs monitoring system in accordance with the present invention includes a sensor unit and one or more receiving apparatus, which transmits health signs data to a network computer such as the MMS. Each receiving apparatus incorporates a display. Thus, the processing of the initialization step (box 802) involves displaying

-17-

health signs information and establishing communications between the sensor unit and the receiving apparatus.

In the next step, represented by the flow diagram box numbered 804, health signs information is sent from the MMS unit to the network. The sending of information can occur at regular time intervals, or whenever there is a need to convey such information, such as when an emergency situation exists or when trouble is indicated. The network can comprise a wide area network, such as the Internet, or can comprise a local network such as an intranet. The network destination for the information may be a monitoring facility staffed by persons who can appropriately respond to the information, or may simply be a computer in another room of the household where the transmitting unit is located.

In the next step, represented by the decision box 806, the system determines whether an action should be performed in response to the health signs information. This decision must be made because it is contemplated that monitored health signs information will typically not require any action beyond normal recording functions that might be desired. Thus, if no such extraordinary action is required, a negative outcome at the decision box 806, then processing returns to the sending of health signs information at box 804. If the health signs information indicates that some action is necessary, a positive outcome at the decision box 806, then processing continues at the flow diagram box numbered 808, which involves responding to the health signs information.

The processing of the information sending at box 804, the decision making at box 806, and the response to information at box 808 may involve a variety of potential scenarios. If the health signs sensor includes a temperature sensor, for example, then the decision may involve a threshold temperature above which trouble is indicated, or a change in magnitude over a predetermined time that indicates trouble. The monitoring system may account for changes in circadian rhythm by checking time-of-day before indicating whether the body temperature of an individual is too high. That is, body temperature in the early afternoon might be expected to be higher than the body temperature in the late evening. Therefore, detected body temperatures might not trigger an alarm condition at certain times of the day, but might trigger an alarm at another time of day. If the health

-18-

signs sensor is a microphone, then the alarm decision may involve a predetermined volume level or a predetermined rate of change or magnitude of increase in volume, above which trouble is indicated. A noise level detected by the microphone that is greater than the threshold predetermined level will be interpreted as a sign of trouble. The health signs sensor may be a combination of position or  
5 movement sensors, in which case the threshold detection may involve sensor orientation, acceleration, or other position change that indicates an undesired change.

Thus, inputs from multiple sensors may be considered in determining if an emergency condition exists. A detected elevation in heart rate may be checked against body temperature, or vice versa, as the two are known to be interrelated. In addition to data values or magnitudes, the system  
10 may consider the magnitude of change or rate of change in a signal.

In the preferred embodiment, the sending of information at the flow diagram box numbered 804 from the MMS unit to the network may involve some decision making at the receiving unit or the MMS unit. The receiving unit or MMS unit may receive temperature data or heart rate data, for example, but might not send all such received data to the network. Rather, the receiving unit or  
15 MMS unit can first process the data to make an alarm or emergency condition determination. Similarly, the receiving unit or MMS unit may receive sound or position information, from which it will determine whether an alarm should be delivered. In this way, some level of operating intelligence would be present in the receiving unit or MMS unit to decide if the health signs information sent to the network (box 804) would consist of an alarm signal or a "clear" signal. Even  
20 in the absence of an alarm signal, the sensor unit sends health signs information to the receiving apparatus. For example, by default, health signs information is sent from the receiving apparatus to the MMS unit at least once every half hour. An emergency condition or other sign of trouble determined at the receiving apparatus results in an immediate transmission of information to the MMS. The data that is sent to the MMS comprises the prior half hour of health signs data. In the  
25 preferred embodiment, the MMS stores such data for each patient, so as to create and maintain a database of patient information.

-19-

In addition to operating intelligence at the receiving unit or MMS unit, there may be some level of operating intelligence at the transmitting unit. The intelligence included in the transmitting unit, for example, may be sufficient to screen or filter the temperature and heart rate data. In that circumstance, the transmitting unit might receive temperature data or heart rate data, but would not send all such data to the receiving unit. Rather, the transmitting unit itself might include operating intelligence, or programming, that would check for rate of change or magnitude of reading before sending health signs information to the receiving unit. In that case, the health signs information sent from the transmitting unit to the receiving unit indicates whether an alarm condition is present and does not necessarily include raw data. As above, this conserves transmission bandwidth and reduces energy consumption. This is especially important for the transmitting unit, which depends on battery power for operation.

The response to the health signs information at box 808 takes place after the information is sent over the network by the MMS unit to a destination network node. The response, however, may involve action at the site of the transmitting unit and receiving unit. For example, the health signs information may indicate that an individual's heart rate is elevated. The response at box 808 may involve controlling a home appliance such as by automatically reducing a home heating thermostat or turning on cooling equipment, or may involve contacting local paramedic or ambulance services. The intelligence to determine that a reduction in temperature is called for and to generate a command to make such a reduction may reside in the destination computer at a network node. Thus, the automatic response to the health signs information may include automatic adjustment of household appliances or systems. If such automatic response is desired, the receiving unit or MMS unit will be adapted to control such external devices.

-20-

### Initialization of Communications and Registration of Transmitting units

As noted above, initialization of the system involves the establishment of communications between a receiving unit and a transmitting unit. Figure 9 is a flow diagram that shows the operating steps executed in performing the initialization and subsequent operation.

In the first step, electrical power is applied to the receiving unit. This step is represented by the flow diagram box numbered 902. The receiving unit next waits to receive a transmitted message from a transmitting unit, as indicated by the flow diagram box numbered 904. In accordance with the preferred embodiment, the control IC chip of each transmitting unit is encoded with a unique identification number at the time of manufacture. Thus, the particular transmitting unit is easily identified during its operation life. The transmitting unit identification number is sent by the IC chip with every transmission, so that a receiving unit can immediately identify the source of a health signs information message. A receiving unit registers the first transmitting unit it identifies after electrical power is applied to the receiver. Upon each power initialization cycle, the receiver again performs the registration function to associate itself with a particular transmitting unit. This is useful for operation in a crowded environment, where multiple transmitter-receiver pairs may be in close proximity and may use the same communications channels. The identification number permits identification of appropriate transmitting units, and exclusion of messages from all others.

Thus, when a transmitted message is received at a receiving unit, the receiving unit determines if it should process the message by first checking to determine if it has registration information from any transmitter. This processing is represented by the decision box numbered 906. If no transmitting unit is registered, a negative outcome at the decision box 906, then the receiving unit registers the transmitter that sent the message, as represented by the flow diagram box numbered 908. To register the transmitting unit, the receiving unit obtains the control IC identification number of the transmitter from the received message and stores it in memory or a register of the receiving unit.

-21-

If there is a transmitting unit already registered, an affirmative outcome at the decision box 906, then the control IC identification number of the transmitter will already have been stored in memory or a register of the receiving unit, and the receiving unit therefore next checks to determine if the registered transmitting unit is the one that sent the received message. If the received message is from the registered transmitting unit, an affirmative outcome at the decision box 910, then the receiving unit processes the received message. This processing is represented by the flow diagram box numbered 912 and can comprise, for example, the actions described at box 808 above in conjunction with Figure 8. The system processing then continues with listening for more transmitted messages at the flow diagram box numbered 904. If the received message is not from a registered transmitter, a negative outcome at the decision box 910, then processing continues with listening at box 904 without processing the received or detected message.

#### Alternative Embodiment: Harness Unit

Rather than clipping the sensor unit illustrated in Figure 1 to a garment, a sensor unit can be integrated with a harness unit. Figure 10 shows a health signs monitoring system 1000 constructed in accordance with this alternative embodiment of the invention. The system 1000 includes a harness unit 1002 that is worn by a patient 1004 whose health signs are to be monitored. As with the clip-on system, the health signs may include patient temperature, heart rate, blood pressure, respiration, oximetry, and sounds or noises in the vicinity of the patient that might indicate trouble or the need for attention. Health signs information from the harness unit is sent by means of wireless transmission 1006 to a receiving apparatus 1008 that processes the information. The receiving apparatus may comprise, for example, any one of the apparatus 112, 114, 116 described above in conjunction with Figure 1.

Figure 11 shows the harness unit 1002 in greater detail. In normal use, a patient's arms are slipped into soft loops 1102, 1104 and a slip clasp 1106 is adjusted so the harness unit is comfortable

-22-

and yet sufficiently snug around the patient's chest so the patient will not disturb the placement of a health sign sensor unit 1108 that continuously measures a vital function or health sign, such as temperature or heart rate. The sensor unit 1108 may be a card unit like the unit 102 described above in conjunction with Figure 2. The soft loops 1102, 1104 include slip clasps 1110, 1112 respectively, 5 that can be adjusted to lengthen or shorten the soft loops to better fit the harness unit 102 to the patient comfortably. All together, the clasps 1106, 1110, 1112 ensure comfortable fitment of the harness to most patients.

Two elastic straps 1114, 1116 of the harness unit 1002 are joined by the first slip clasp 1106. The joined straps will tend to remain above the upper curve of the back, just below the neck, because 10 the straps will resist stretching over the bony hump caused by the physiognomy of the upper back. This helps ensure that the entire harness unit 102 will remain in a preferred position for best operation of the health sign sensor.

The harness unit 1002 may include multiple sensors or sensor units that produce signals that indicate the health signs that are to be monitored. In the preferred embodiment, for example, the first 15 health sensor 1108 comprises a temperature sensitive sensor, such as a thermistor. The sensor may be attached to one of the soft loops 1102 or straps 1114, 1116 so that a patient properly wearing the harness unit 102 will be able to attach the sensor so it is in continuous external contact with the patient's armpit. The temperature sensor is preferably of thin, elongated construction, and is secured at both ends to the loop 1102 with a soft, flexible connection. In this way, the harness unit and 20 temperature sensor can be worn in place comfortably for extended periods of time.

If desired, an additional health sign sensor 1120 can be located on the other soft loop 1104. The additional sensor can be another temperature sensor, or can be a heart rate sensor, or some other health signs sensor. For example, one or both of the sensors 1108, 1120 can provide sound 25 detection, because the presence or absence of sounds can indicate whether the patient is experiencing difficulty. The sensor may detect the absence of breathing sounds, or the cries of a baby, or a falling patient or object, for example. The sensors 1108, 1120 can provide patient orientation information as a health sign. That is, the sensors may comprise simple mercury switches that can indicate when

-23-

the patient has fallen or rolled over. Such patient position information can be critical under some circumstances, such as with small children or the elderly.

If the sensors 1108, 1120 are not constructed as sensor units 102 (Figure 1) with transmitters, then the harness unit 102 includes a transmitting unit 1122 that receives the health signal from the sensors 1108, 1120 and transmits the signal(s) to the receiving apparatus 1008 (Figure 10). The transmitting unit can be positioned on top of the individual's shoulder, or can be placed on the outside of one loop or the other, for greater comfort in wearing the harness. The transmitting unit can make use of conventional radio frequency (RF) transmission techniques, which are well-known to those skilled in the art. Alternatively, the transmitting unit can make use of so-called "Personal Area Network" technology that utilizes low-voltage of the human body to electrically transfer information from the body of an individual. That is, the wireless transmission link can comprise Personal Area Network technology that eliminates the need for electromagnetic transmission, such as radio frequency (RF) signals. The health signs monitoring system with Personal Area Network technology thereby is not affected by most RF energy, and does not interfere with the operation of RF-sensitive equipment.

The system described above provides convenient and minimally intrusive monitoring of health signs, with dependable monitoring of the health signs for any indication of trouble in the home environment and in the hospital environment. In accordance with the invention, health signs of an individual are detected with health signs sensor unit producing health sign characteristics of the individual, which sends health signals to a receiving apparatus over a wireless connection and to a computer network. The system then processes the signal at a remote node of the computer network to indicate if an emergency condition exists and thereby permits dependable monitoring of an individual's health signs in a relatively convenient and minimally intrusive manner.

Other features may be added to a health signs monitoring system without departing from the teachings of the invention. For example, the analysis of health signs may comprise analysis of detected sound that is displayed in a graphical format, with the graphical representation data transmitted over a network or via modem. An emergency condition may then be triggered, as

-24-

appropriate. One implementation of such an analysis feature may involve a microphone detecting heart and lung sounds, and producing a graphical display for analysis. The sound data can be stored and any anomaly can trigger an emergency condition notification. In addition to the monitoring function, the system can perform analysis of captured data on demand. For example, the system can  
5 be constructed to permit comparison of health signs data with data from a database to make a determination of emergency condition. In particular, the system may capture image data with a video camera and the image data can be compared to stored images to determine if a rash, for example, comprises an emergency condition. Other devices may physically initiate health signs data for analysis, such as a device that can be placed on the body to prompt a reflex action from the knee  
10 or ankle. Sound data can be collected, if desired, as described above.

The present invention has been described above in terms of presently preferred embodiments so that an understanding of the present invention can be conveyed. There are, however, many configurations for client-server computer systems not specifically described herein but with which the present invention is applicable. The present invention should therefore not be seen as limited  
15 to the particular embodiments described herein, but rather, it should be understood that the present invention has wide applicability with respect to client-server computer systems generally. All modifications, variations, or equivalent arrangements and implementations that are within the scope of the attached claims should therefore be considered within the scope of the invention.

-25-

## CLAIMS

### I CLAIM:

- 1           1.       A method for monitoring health signs of an individual, the method comprising:  
2           detecting at least one health sign characteristic of the individual with a health signs sensor  
3           unit that is located proximate the individual;  
4           producing a health signal from the health signs sensor unit that indicates at least one health  
5           sign of the individual;  
6           communicating the health signal from the individual to a receiving apparatus over a wireless  
7           connection;  
8           processing the health signal to determine if an emergency condition exists; and  
9           providing an indication of an emergency condition to a destination node of a network.
  
- 1           2.       A method as defined in claim 1, wherein the step of processing the health signal  
2           comprises receiving the signal at a multimedia server connected to the network, wherein the  
3           multimedia server determines if an emergency condition exists and, in response, transmits an  
4           emergency signal.
  
- 1           3.       A method as defined in claim 1, wherein the receiving apparatus processes the health  
2           signal with information from an ambient environmental sensor.
  
- 1           4.       A method as defined in claim 3, wherein the receiving apparatus processes the health  
2           signal by compensating for ambient temperature.
  
- 1           5.       A method as defined in claim 3, wherein the receiving apparatus processes the health  
2           signal by compensating for expected time of day fluctuation in the health signal.

-26-

1           6.     A method as defined in claim 1, wherein:  
2     the health signs sensor unit comprises a temperature sensor that is attached to the individual  
3             and produces a temperature signal;  
4     the temperature signal comprises a temperature indicator of whether the individual is in a  
5             safe or emergency temperature condition; and  
6     the step of producing a health signal comprises producing a temperature signal that indicates  
7             a temperature characteristic of the individual, in response to the temperature  
8             indication.

1           7.     A method as defined in claim 1, wherein:  
2     the health signs sensor unit includes a microphone that produces a sound signal in response  
3             to sound;  
4     the health sign characteristic comprises a relatively loud sound emanating from the  
5             individual or from the area immediately around the individual; and  
6     the step of producing a health signal comprises producing a loudness signal that indicates a  
7             sound characteristic, in response to the sound signal.

1           8.     A method as defined in claim 1, wherein:  
2     the health signs sensor unit comprises a position detector that is attached to the individual  
3             and produces a health signal;  
4     the health signal comprises a position indication of whether the individual is in an upright  
5             or a horizontal position; and  
6     the step of producing a health signal comprises producing a digital position signal that  
7             indicates a position characteristic of the individual, in response to the position  
8             indication.

-27-

1           9.     A method as defined in claim 1, further comprising:  
2           applying operating electrical power to the receiving unit in an initialization mode;  
3           waiting at the receiving apparatus for a received identification signal from the health signs  
4           sensor unit; and  
5           receiving a health signal only from a sensor unit having the received identification signal.

1           10.    A method as defined in claim 9, further comprising:  
2           halting the application of operating electrical power; and  
3           repeating the steps of waiting and receiving upon resuming the application of operating  
4           electrical power, until a next received identification signal is received.

1           11.    A method as defined in claim 9, further comprising the step of receiving a forced  
2           identification signal from an external transmitter and thereafter receiving a health signal only from  
3           a sensor unit having the received identification signal.

1           12.    A method as defined in claim 1, wherein the step of processing the provided signal  
2           comprises responding to an emergency condition and, in response, activating a sensor.

1           13.    A method as defined in claim 1, wherein the step of processing the provided signal  
2           comprises responding to an emergency condition and, in response, activating a response device.

1           14.    A method as defined in claim 1, wherein the sensor unit receives electrical power  
2           from a battery, and the method further includes the step of determining battery power by counting  
3           the number of health signals transmissions that have occurred since electrical power was last applied,  
4           and providing an indication of low battery power when a predetermined number of transmissions  
5           have occurred.

-28-

1           15.    A method for continuously monitoring health signs of a patient over an extended  
2 period of time, the method comprising:

3           attaching a sensor unit to the patient;

4           producing a patient signal that indicates the current status of a patient health sign;

5           wirelessly transmitting the patient signal to a receiving apparatus;

6           processing the patient signal to determine if the patient's current health sign status indicates  
7           an emergency condition and sending it over a network to a destination device; and

8           displaying the patient's current health sign status at the receiving apparatus.

1           16.    A method as defined in claim 15, wherein the step of processing the patient signal  
2 comprises receiving the patient signal at a multimedia server connected to the network, wherein the  
3 multimedia server determines if an emergency condition exists and, in response, transmits an  
4 emergency signal over the network.

1           17.    A method as defined in claim 15, wherein the receiving apparatus processes the health  
2 signal with information from an ambient environmental sensor before providing the communicated  
3 health signal to the network.

1           18.    A method as defined in claim 17, wherein the receiving apparatus processes the health  
2 signal by compensating for ambient temperature.

1           19.    A method as defined in claim 17, wherein the receiving apparatus processes the health  
2 signal by compensating for expected time of day fluctuation in the health signal.

1           20.    A method as defined in claim 16, wherein the step of processing the patient signal  
2 comprises responding to the existence of an emergency condition and, in response, activating a  
3 sensor.

-29-

1           21.    A method as defined in claim 16, wherein the step of processing the patient signal  
2 comprises responding to the existence of an emergency condition and, in response, activating a  
3 household appliance.

1           22.    A method as defined in claim 20, further comprising the step of receiving a forced  
2 identification signal from an external transmitter and thereafter receiving a health signal only from  
3 a sensor unit having the received identification signal.

1           23.    A method as defined in claim 15, wherein the sensor unit receives electrical power  
2 from a battery, and the method further includes the step of determining battery power by counting  
3 the number of health signals transmissions that have occurred since electrical power was last applied,  
4 and providing an indication of low battery power when a predetermined number of transmissions  
5 have occurred.

1           24.    A system that monitors health signs of an individual, the system comprising:  
2 a health signs sensor unit that is located proximate the individual and produces a health  
3 signal that indicates at least one health sign of the individual;  
4 a receiving apparatus that receives the health signs signal from the sensor unit over a wireless  
5 connection and determines if an emergency condition exists; and  
6 a multimedia server that communicates with the receiving apparatus and with a network,  
7 sends an indication of an emergency condition to a network destination node.

1           25.    A system as defined in claim 24, wherein:  
2 the health signs sensor unit comprises a temperature sensor that is attached to the individual  
3 and produces a temperature signal;  
4 the temperature signal comprises a temperature indicator of whether the individual is in a  
5 safe or emergency temperature condition; and

-30-

6 the sensor unit produces a temperature signal that indicates a temperature characteristic of  
7 the individual, in response to the temperature indication.

1 26. A system as defined in claim 24, wherein the receiving apparatus processes the health  
2 signal with information from an ambient environmental sensor before providing the communicated  
3 health signal to the network.

1 27. A system as defined in claim 26, wherein the receiving apparatus processes the health  
2 signal by compensating for ambient temperature.

1 28. A system as defined in claim 26, wherein the receiving apparatus processes the health  
2 signal by compensating for expected time of day fluctuation in the health signal.

1 29. A system as defined in claim 24, wherein:  
2 the health signs sensor comprises a microphone that produces a sound signal in response to  
3 sound;  
4 the health sign characteristic comprises a relatively loud sound emanating from the  
5 individual or from the area immediately around the individual; and  
6 the sensor unit produces a loudness signal that indicates a sound characteristic, in response  
7 to the sound signal.

1 30. A system as defined in claim 24, wherein:  
2 the health signs sensor comprises a position detector that is attached to the individual and  
3 produces a health signal;  
4 the health signal comprises a position indication of whether the individual is in an upright  
5 or a horizontal position; and

-31-

6 the sensor unit produces a position signal that indicates a position characteristic of the  
7 individual, in response to the position indication.

1 31. A system as defined in claim 24, wherein the receiving apparatus operates such that,  
2 upon the application of electrical power in an initialization mode, it waits for a received  
3 identification signal from the sensor unit and registers a sensor unit identification code, and  
4 thereafter responds to a health signal only from a sensor unit having the registered identification  
5 signal.

1 32. A system as defined in claim 31, wherein the receiving apparatus operates in the  
2 initialization mode at each application of electrical power, such that it registers a sensor unit  
3 identification code after each initialization.

1 33. A system as defined in claim 31, wherein the receiving apparatus receives a forced  
2 identification signal from an external transmitter and thereafter receives a health signal only from  
3 a sensor unit having the received identification signal.

1 34. A system as defined in claim 24, wherein the receiving apparatus processes the  
2 provided signal by activating a sensor.

1 35. A system as defined in claim 24, wherein the system determines an emergency  
2 condition by considering multiple health signs signals.

1 36. A system as defined in claim 24, wherein the sensor unit is attached to a harness worn  
2 by the patient.

-32-

1           37.    A system as defined in claim 24, wherein the sensor unit is attached to a garment  
2 worn by the patient.

1           38.    A system as defined in claim 37, wherein the system indicates an emergency  
2 condition if the sensor unit is removed from the garment.

1           39.    A system as defined in claim 24, wherein the receiving apparatus includes a display  
2 that provides a predetermined message in response to an emergency condition.

1           40.    A system as defined in claim 39, wherein the predetermined message comprises an  
2 advertisement for a product that may be used to treat the emergency condition.

1           41.    A system as defined in claim 24, wherein the receiving unit processes the provided  
2 signal by activating a household device.

1           42.    A system as defined in claim 24, wherein the sensor unit receives electrical power  
2 from a battery, and the method further includes the step of determining battery power by counting  
3 the number of health signals transmissions that have occurred since electrical power was last applied,  
4 and providing an indication of low battery power when a predetermined number of transmissions  
5 have occurred.

1           43.    A receiving apparatus for operation in a system that monitors health signs of an  
2 individual, the receiving apparatus comprising:

3           a receiver that receives a health signs signal from a sensor unit over a wireless connection,  
4 wherein the sensor unit is worn by an individual and includes a health signs sensor that is located  
5 proximate the individual and produces the health signal, which indicates at least one health sign of  
6 the individual;

-33-

7 a display that indicates operating status of the receiving apparatus;  
8 a control circuit that controls operation of the receiving apparatus for processing of the  
9 received health signs signal to determine if an emergency condition exists; and  
10 an interface to a multimedia server to which the receiving apparatus provides an indication  
11 of an emergency condition and, if one does, sends an indication to a network.

1 44. A receiving apparatus as defined in claim 43, wherein the health signal received by  
2 the receiving apparatus comprises a digital temperature signal that indicates a temperature  
3 characteristic of the individual, in response to a temperature signal of the health signs sensor unit.

1 45. A receiving apparatus as defined in claim 43, wherein the receiving apparatus  
2 processes the health signal with information from an ambient environmental sensor before providing  
3 the communicated health signal to the network.

1 46. A receiving apparatus as defined in claim 43, wherein the receiving apparatus  
2 processes the health signal by compensating for ambient temperature.

1 47. A receiving apparatus as defined in claim 45, wherein the receiving apparatus  
2 processes the health signal by compensating for expected time of day fluctuation in the health signal.

1 48. A receiving apparatus as defined in claim 43, wherein the health signal received by  
2 the receiving apparatus comprises a loudness signal that indicates a sound characteristic, in response  
3 to a sound signal of the health signs sensor unit.

1 49. A receiving apparatus as defined in claim 43, wherein the health signal received by  
2 the receiving apparatus comprises a position signal that indicates a position characteristic of the  
3 individual, in response to a position indication of the health signs sensor unit.

-34-

1           50.    A receiving apparatus as defined in claim 43, wherein the receiving apparatus  
2 operates such that, upon the application of electrical power in an initialization mode, it waits for a  
3 received identification signal from the sensor unit and registers a sensor unit identification code, and  
4 thereafter responds to a health signal only from a sensor unit having the registered identification  
5 signal.

1           51.    A receiving apparatus as defined in claim 50, wherein the receiving apparatus  
2 operates in the initialization mode at each application of electrical power, such that it registers a  
3 sensor unit identification code after each initialization.

1           52.    A receiving apparatus as defined in claim 50, further comprising the step of receiving  
2 a forced identification signal from an external transmitter and thereafter receiving a health signal  
3 only from a sensor unit having the received identification signal.

1           53.    A receiving apparatus as defined in claim 43, wherein the receiving apparatus  
2 processes the provided signal by activating a sensor.

1           54.    A receiving apparatus as defined in claim 43, wherein the receiving apparatus  
2 processes the provided signal by activating a device.

1           55.    A receiving apparatus as defined in claim 43, wherein the sensor unit receives  
2 electrical power from a battery, and the method further includes the step of determining battery  
3 power by counting the number of health signals transmissions that have occurred since electrical  
4 power was last applied, and providing an indication of low battery power when a predetermined  
5 number of transmissions have occurred.

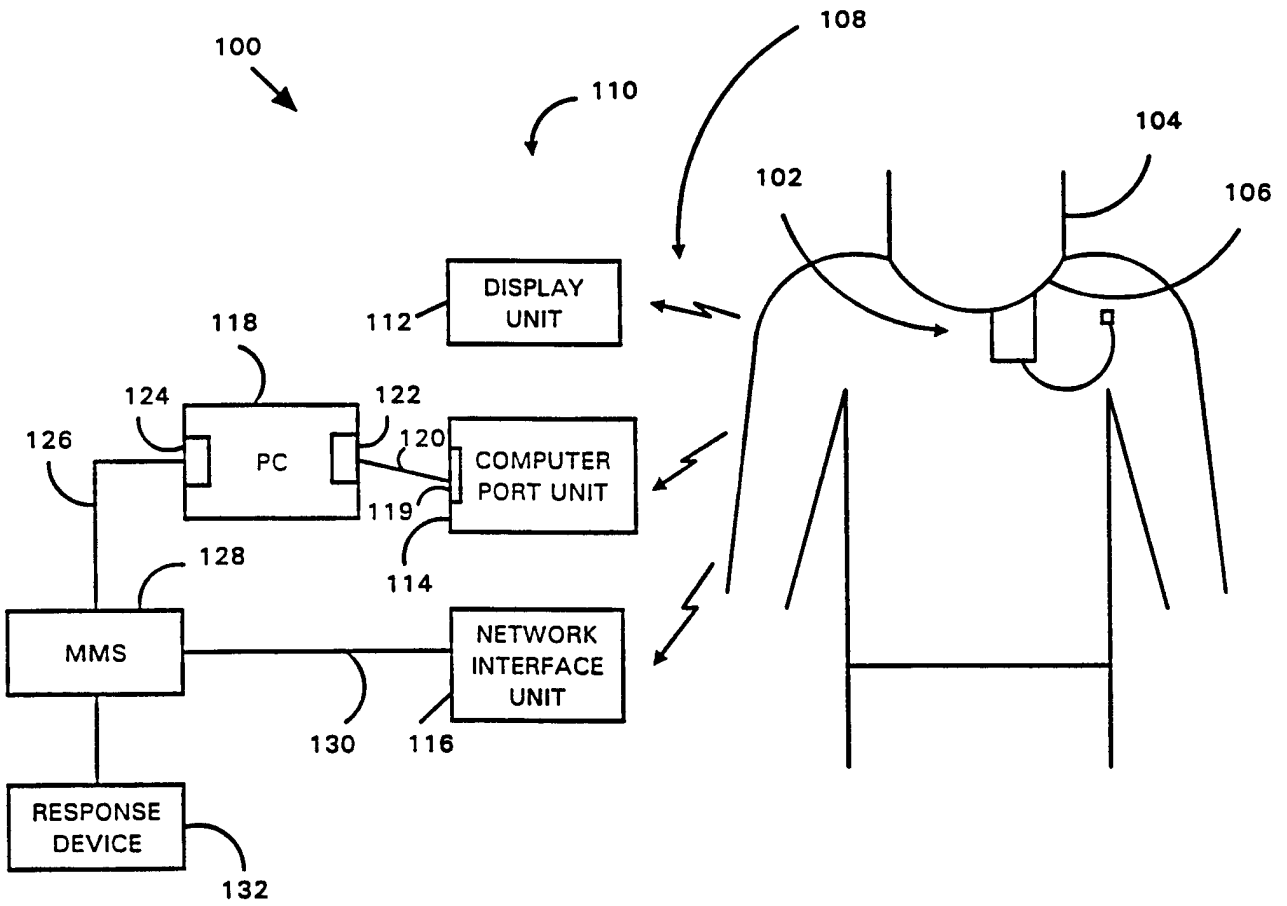

FIG. 1

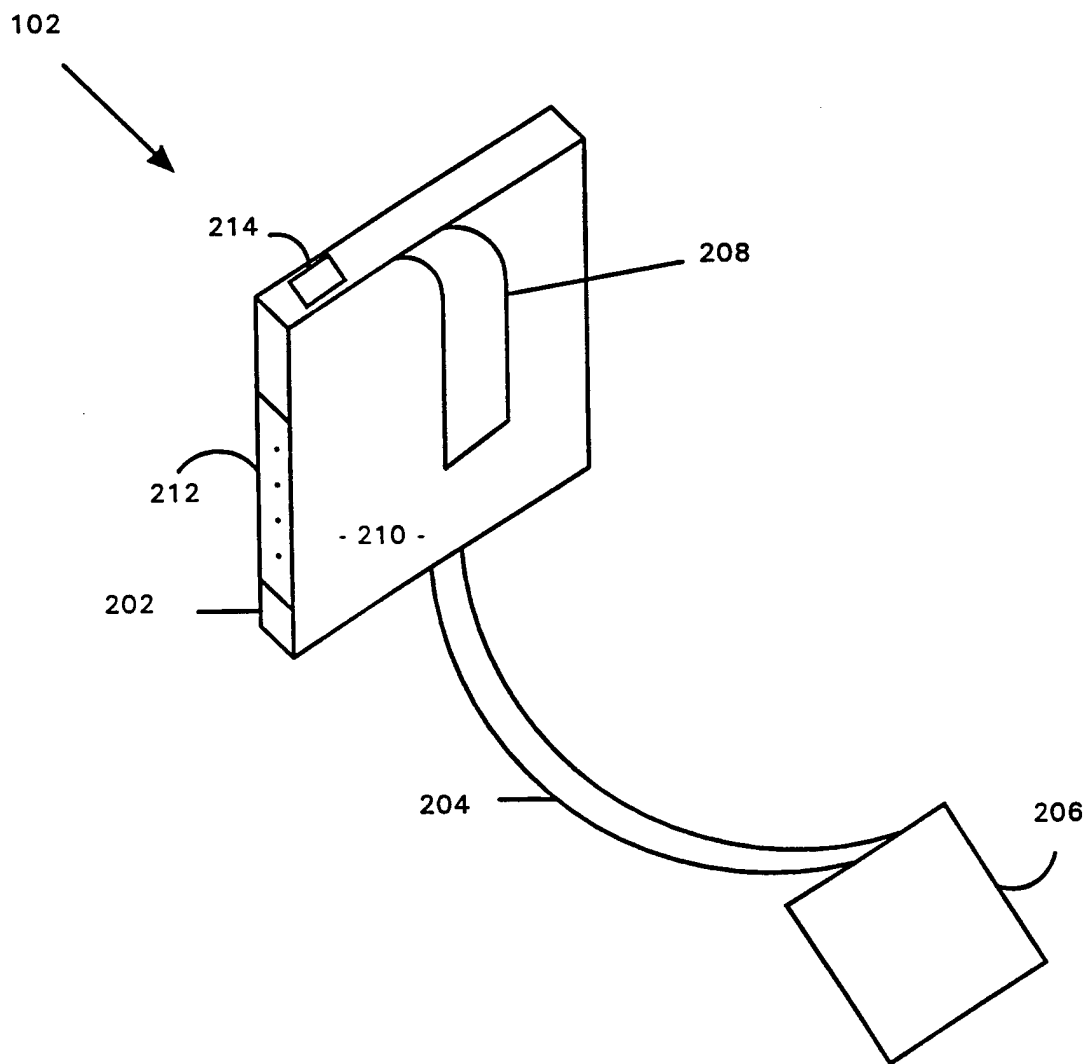

FIG. 2

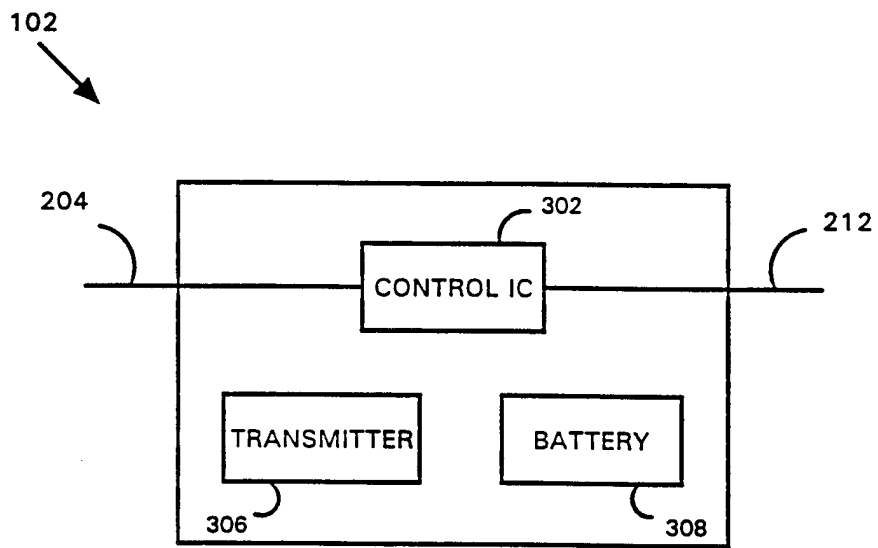

FIG. 3

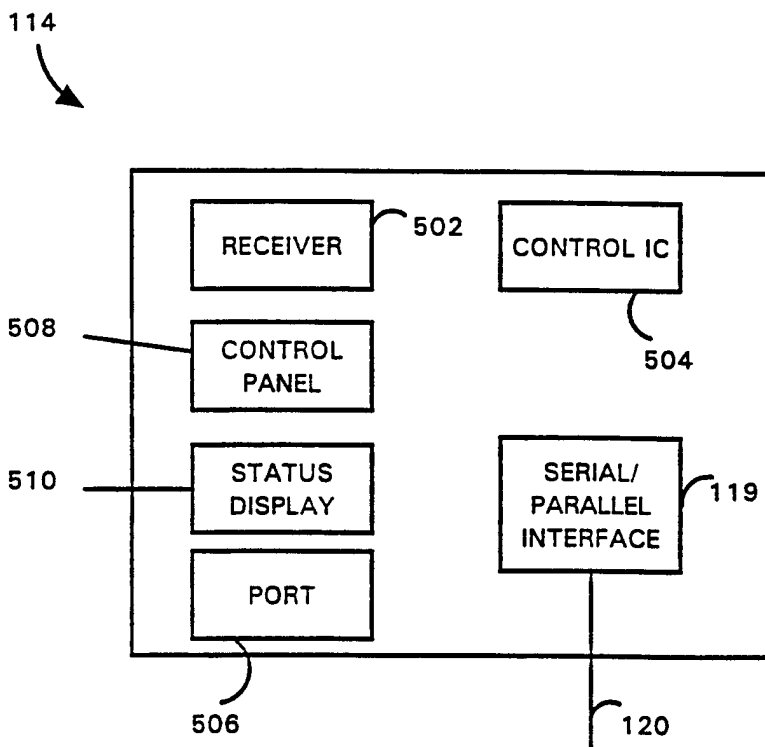

FIG. 5

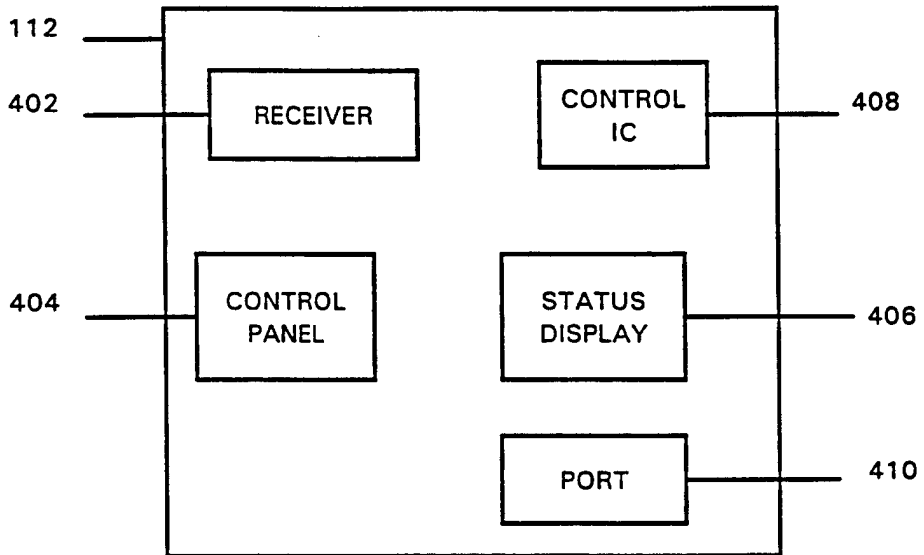

FIG. 4

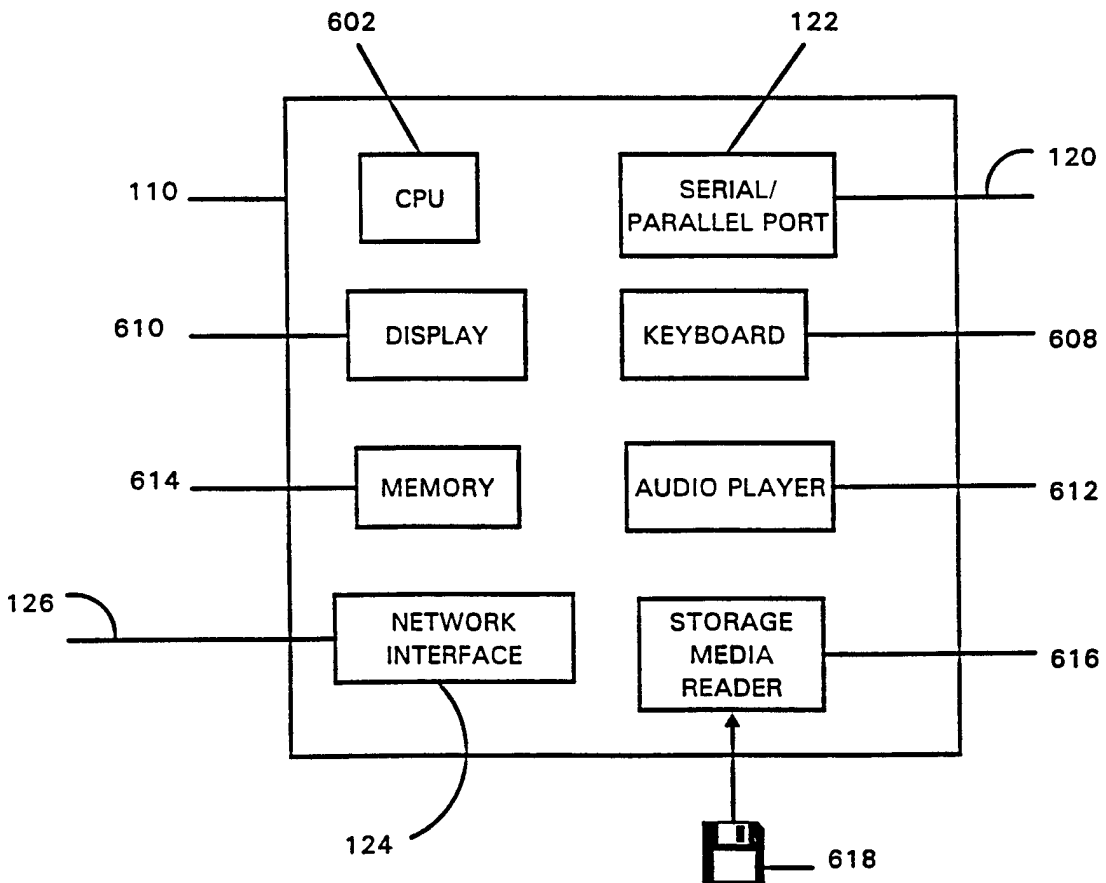

FIG. 6

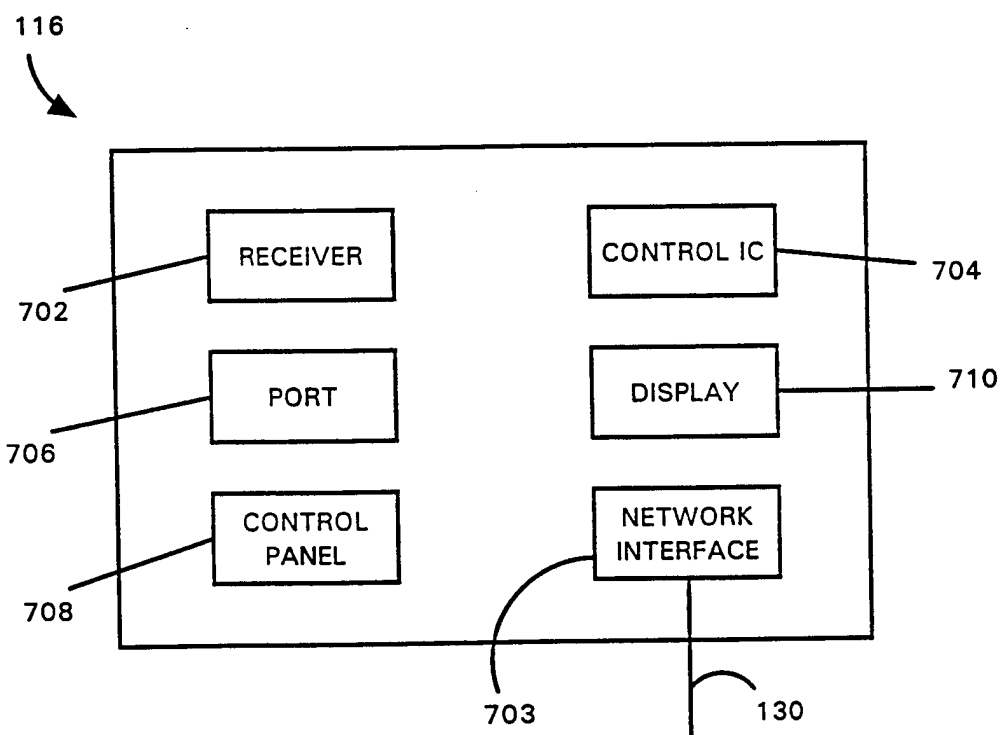
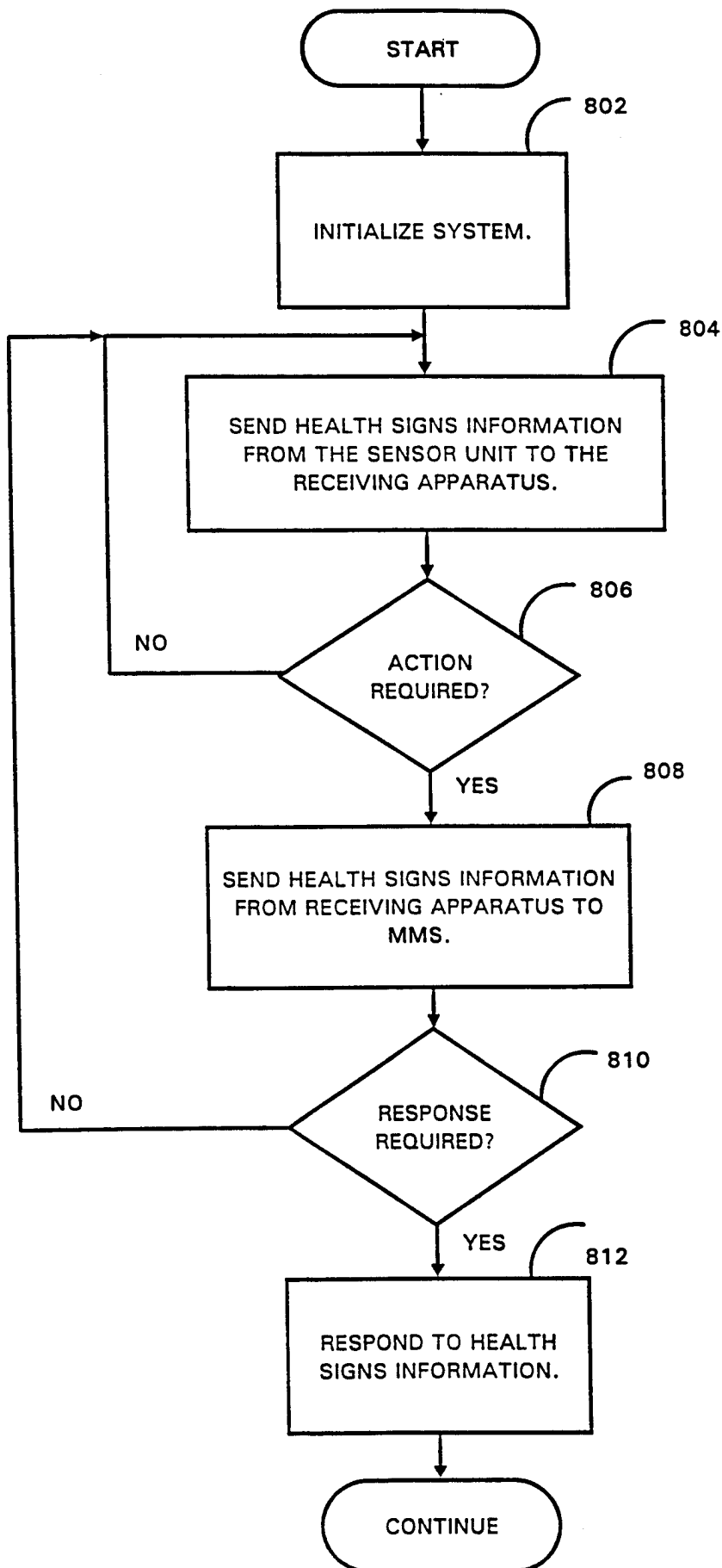

FIG. 7

6/8



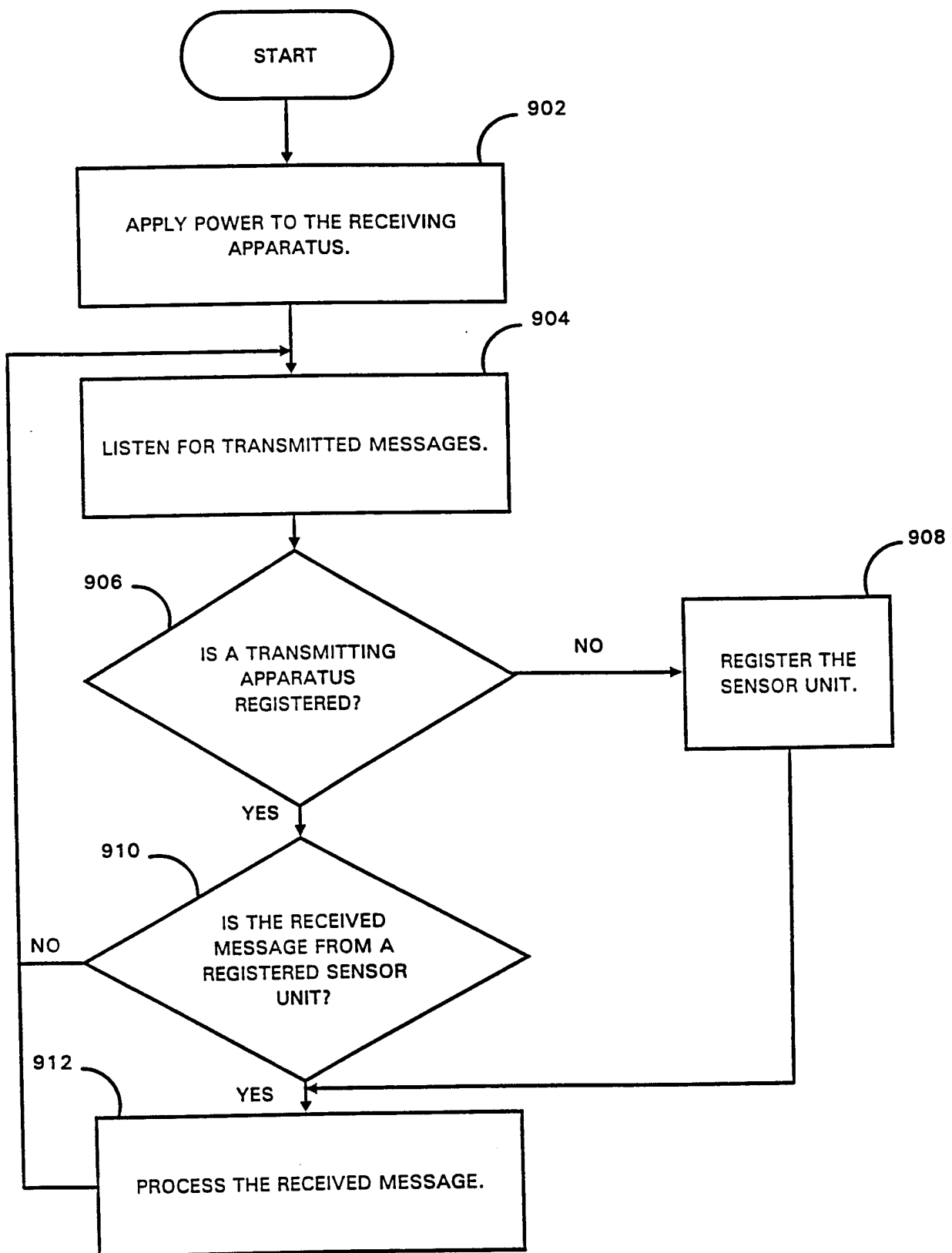

FIG. 9

1000

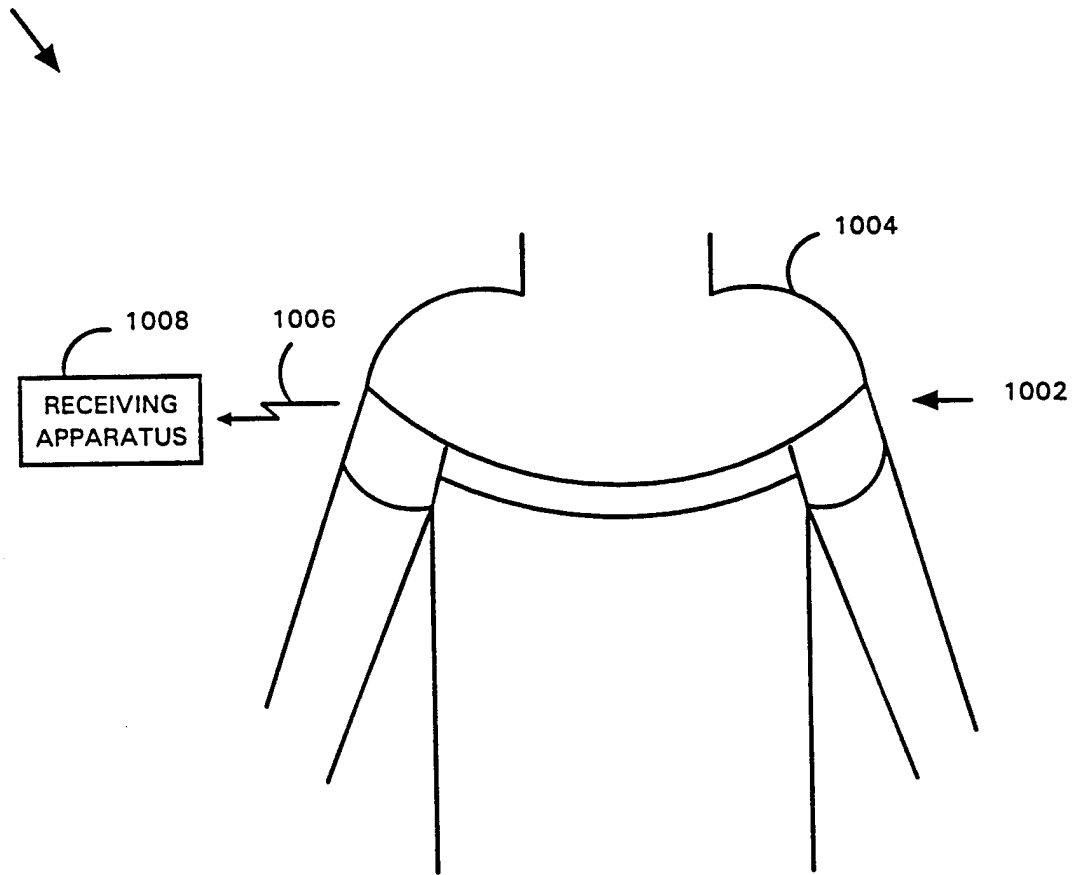

FIG. 10

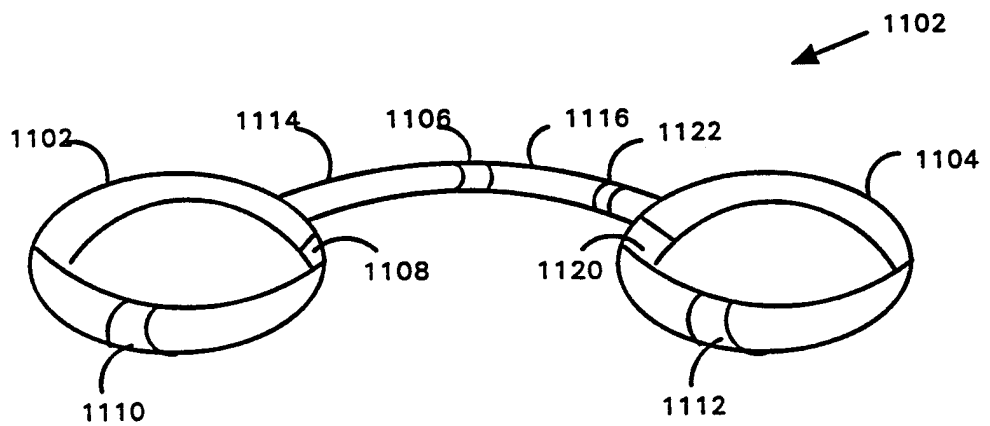

FIG. 11

专利名称(译)	用于健康标志监测的方法和设备		
公开(公告)号	<a href="#">EP1115325A2</a>	公开(公告)日	2001-07-18
申请号	EP2000930321	申请日	2000-05-03
[标]申请(专利权)人(译)	FEVER手表		
申请(专利权)人(译)	FEVER WATCH , LLC		
[标]发明人	FEVER WATCH LLC		
发明人	FEVER WATCH, LLC		
IPC分类号	A61B5/00 A61B1/00		
CPC分类号	A61B5/6831 A61B5/0002 A61B5/0024 A61B5/1117		
优先权	09/306907 1999-05-07 US		
外部链接	<a href="#">Espacenet</a>		

#### 摘要(译)

用于监测个体的健康体征的系统利用位于个体附近的传感器单元检测个体的至少一个健康体征特征，从传感器产生指示个体的至少一个健康体征的健康信号，传达通过无线连接从个人到接收设备的健康信号将所传送的健康信号提供给网络，并在网络的目的节点处处理所提供的信号以指示是否存在紧急情况。系统通过无线传输链路和计算机网络将健康信号发送到接收设备，并在目的地节点处处理该信号以指示是否存在紧急情况。与无线传输链路相关联的组件足够小并且重量轻，使得组件可以被夹在患者衣服上或在线束上，其可以由患者佩戴而没有过度的不适。