

(19)



(11)

**EP 3 420 991 A1**

(12)

**EUROPEAN PATENT APPLICATION**

(43) Date of publication:  
**02.01.2019 Bulletin 2019/01**

(51) Int Cl.:  
**A61B 18/00 (2006.01) A61B 18/14 (2006.01)**  
**A61B 5/00 (2006.01)**

(21) Application number: **18187012.2**

(22) Date of filing: **11.02.2015**

(84) Designated Contracting States:  
**AL AT BE BG CH CY CZ DE DK EE ES FI FR GB  
GR HR HU IE IS IT LI LT LU LV MC MK MT NL NO  
PL PT RO RS SE SI SK SM TR**

- **AUERBACH, Shmuel**  
**3084000 Kerem Maharal (IL)**
- **URMAN, Roy**  
**3706315 Karkur (IL)**
- **ZRIHAM, Yaniv Ben**  
**3051732 Binyamina (IL)**
- **PRESSMAN, Assaf**  
**3701015 Pardes Hanna-Karkur (IL)**

(30) Priority: **12.02.2014 US 201461938863 P**  
**23.01.2015 US 201514603415**

(62) Document number(s) of the earlier application(s) in  
accordance with Art. 76 EPC:  
**15154737.9 / 2 907 462**

(74) Representative: **Small, Gary James**  
**Carpmaels & Ransford LLP**  
**One Southampton Row**  
**London WC1B 5HA (GB)**

(71) Applicant: **Biosense Webster (Israel) Ltd.**  
**Yokneam 2066717 (IL)**

Remarks:

This application was filed on 02.08.2018 as a  
divisional application to the application mentioned  
under INID code 62.

- (72) Inventors:
- **ZINO, Eliahu**  
**3030000 Atlit (IL)**
  - **IGRA, Noam**  
**4668601 Herzelia (IL)**

(54) **CATHETER WITH TRANSVERSE BRANCHES**

(57) Apparatus, including a flexible insertion tube,  
having a distal segment that is configured to be inserted  
into a body organ. A plurality of elastic branches are con-  
nected to the distal segment of the insertion tube at dif-  
ferent, respective locations and extend transversely

away from the insertion tube at the respective locations.  
There are one or more respective electrodes disposed  
on each of the elastic branches and there are conductors  
traversing the elastic branches so as to couple the elec-  
trodes to the insertion tube.

**EP 3 420 991 A1**

**Description****CROSS-REFERENCE TO RELATED APPLICATION**

[0001] This application claims the benefit of U.S. Provisional Patent Application 61/938,883, filed February 12, 2014, which is incorporated herein by reference.

**FIELD OF THE INVENTION**

[0002] The present invention relates generally to a catheter having a number of electrodes, and specifically to the design and operation of such a catheter.

**BACKGROUND OF THE INVENTION**

[0003] Catheters with electrodes are used in a number of medical procedures, such as investigating or operating on a region of the heart. In these procedures the electrodes may be used, for example, to inject known currents (typically for catheter tracking purposes), to measure electropotentials of specific regions of the heart, and/or to ablate the regions. While catheters with a small number of electrodes, or even with a single electrode, may be used for such procedures, certain software algorithms may increase the value of having large number of electrodes on the catheter. Such an arrangement allows a physician using the catheter to select which of one or more of the electrodes may be used, and also to select if the electrodes are to be used simultaneously or not.

**SUMMARY OF THE INVENTION**

[0004] An embodiment of the present invention provides apparatus, including:

a flexible insertion tube, having a distal segment that is configured to be inserted into a body organ;  
 a plurality of elastic branches connected to the distal segment of the insertion tube at different, respective locations and extending transversely away from the insertion tube at the respective locations;  
 one or more respective electrodes disposed on each of the elastic branches; and  
 conductors traversing the elastic branches so as to couple the electrodes to the insertion tube.

[0005] Typically, each of the elastic branches consists of an elastic region and an inelastic region. The elastic region may be closer to the flexible insertion tube than the inelastic region. On application of a bending force to a branch, the inelastic region typically aligns to be parallel to the insertion tube. On removal of the bending force the inelastic region typically returns to extending transversely away from the insertion tube.

[0006] In a disclosed embodiment the different respective locations of a pair of the elastic branches lie on a cross-sectional circle of the flexible insertion tube.

[0007] In a further disclosed embodiment, for a cross-sectional circle of the flexible insertion tube only one of the elastic branches is connected to the circle.

[0008] In a yet further disclosed embodiment the elastic branches and the distal segment lie in a common flat plane. Alternatively, the elastic branches and the distal segment lie in a plurality of planes.

[0009] The elastic branches may be orthogonal to the distal segment. Alternatively, the elastic branches may extend non-orthogonally from the distal segment.

[0010] In an alternative embodiment the body organ consists of a heart, and the one or more respective electrodes are configured to acquire an electrocardiograph (ECG) signal from the heart. Alternatively or additionally the one or more respective electrodes are configured to ablate tissue of the heart.

[0011] The distal segment in a relaxed state may form a straight line or may form a curve.

[0012] There is further provided, according to an embodiment of the present invention, a method, including:

providing a flexible insertion tube, having a distal segment that is configured to be inserted into a body organ;  
 connecting a plurality of elastic branches to the distal segment of the insertion tube at different, respective locations so that the branches extend transversely away from the insertion tube at the respective locations;  
 disposing one or more respective electrodes on each of the elastic branches; and  
 arranging conductors to traverse the elastic branches so as to couple the electrodes to the insertion tube.

[0013] The present disclosure will be more fully understood from the following detailed description of the embodiments thereof, taken together with the drawings, in which:

**BRIEF DESCRIPTION OF THE DRAWINGS****[0014]**

Figs. 1A and 1B illustrate schematically a catheter distal portion in two states, according to an embodiment of the present invention;

Figs. 2A and 2B illustrate schematically a catheter distal portion in two states, according to an alternative embodiment of the present invention;

Fig. 3 illustrates schematically a distal portion of a flexible insertion tube, according to an embodiment of the present invention;

Fig. 4 illustrates schematically a distal portion of a flexible insertion tube, according to an alternative embodiment of the present invention; and

Fig. 5 is a schematic illustration of a medical procedure system, according to an embodiment of the

present invention.

## DETAILED DESCRIPTION OF EMBODIMENTS

### OVERVIEW

**[0015]** Catheters for performing a medical procedure typically have as small a diameter as possible so as to reduce trauma to a patient undergoing the procedure. However, the small diameter of the catheter limits the number of structures that may be attached to the shaft of the catheter. Furthermore, the catheter may be advanced through the body of the patient using an elongated sheath, and the sheath may restrict the structures which can be retracted back into the sheath. Thus, in the case of a catheter using a large number of electrodes, such as a catheter used for acquiring numbers of simultaneous electrocardiograph (ECG) signals, prior art catheters may be relatively large in order to accommodate the large number of electrodes.

**[0016]** Embodiments of the present invention solve these problems by providing a catheter with a relatively small diameter flexible insertion tube, which may be considered to act as the spine of the catheter. Connected to a distal segment of the tube are a plurality of elastic branches which extend transversely away from the tube. One or more electrodes are disposed on the branches, and conductors traverse the branches and the insertion tube, so as to couple the electrodes to a proximal end of the tube.

**[0017]** By configuring the catheter branches to be elastic, they are able to bend in towards the catheter spine. Thus, in operation, the catheter may be inserted into, and removed from, an organ such as the heart via a relatively small diameter sheath, which is prepositioned in the organ. While in the sheath, the branches bend in towards the spine. Once inside the organ, the branches can unbend and the electrodes of the branches may be used to transfer electrical signals to/from the organ.

### DETAILED DESCRIPTION

**[0018]** Figs. 1A and 1B illustrate schematically a distal portion 10 of a flexible insertion tube 11 in two states, according to an embodiment of the present invention. Fig. 1A illustrates the distal portion in an unfolded, relaxed, or unbent, state; Fig. 1B illustrates the distal portion in a folded, or bent, state. Tube 11 may be used as a catheter, and is also referred to herein as catheter 11. Distal portion 10 comprises a distal segment 12, which is typically generally cylindrical and which acts as a main spine of the flexible insertion tube, so that it is also referred to herein as main spine 12. In the relaxed state of tube 11, the spine forms a straight line. A plurality of generally similar elastic branch elements 14, also typically generally cylindrical, and also referred to herein as elastic branches 14, are connected to the distal segment. The connection of the branch elements to the main spine is

configured so that at any given junction the two entities, the element and the spine, are transverse to each other, so that the branch elements protrude from the distal segment.

**[0019]** As is illustrated in the figures, in distal portion 10 elements 14 are paired together, so that the locations of the junctions between any given pair of elements 14 with spine 12 lie on a cross-sectional circle 23 of the spine. (For clarity and simplicity, only one such cross-sectional circle is shown in the figures.) In some embodiments the branch elements are orthogonal to spine 12, so that, for example, if the junctions are on a diameter of the cross-sectional circle, elements 14 subtend an angle of 180° to each other. Alternatively, junctions of the orthogonal branch elements may lie on the cross-sectional circle, but the elements may subtend an angle other than 180° to each other, for example angles in the range of 45° - 179°. In other embodiments at least some of the branch elements are not orthogonal to the spine, but rather subtend an angle to the spine that is greater than, or less than, 90°.

**[0020]** Each branch element 14 comprises one or more, typically a multiplicity, of electrodes 16 that may be formed as a ring around the element. Alternatively or additionally, at least some of electrodes 16 may be formed as flat structures on the branch element. The material of spine 12, elements 14, and electrodes 16 are selected to be biocompatible. The electrodes are connected, at a proximal end of catheter 11, via respective conductors 13 in the elements and in the spine, to an operating console which is able to receive electrical signals from, and/or transmit electrical signals to, the electrodes. For simplicity only two conductors 13 are shown in Figs. 1A and 1B. A suitable operating console is provided in the Carto® system, produced by Biosense Webster, of Diamond Bar, CA. The console is typically configured to provide other functions for the distal portion, such as tracking the distal portion. The console is not shown in Figs. 1A and 1B, but is shown, and console functions are described, with reference to Fig. 3 below.

**[0021]** Typical dimensions of spine 12 are approximately 1 m in length and 1.5 mm - 2 mm in diameter (only the distal portion of the spine is shown in the figures), and in some embodiments ring electrodes 22 are also formed around spine 12. Ring electrodes 22 are connected via respective conductors 17 (only one of which is shown in the figures) to the operating console. Typical dimensions of elements 14 are approximately 1.5 cm - 2 cm in length and 1 mm diameter. However, the lengths and diameters of spine 12 and elements 14 may be larger or smaller than these values.

**[0022]** Distal portion 10 is configured to be inserted into an organ, such as the heart, of a patient, so that all parts of the distal portion are formed from biocompatible materials. In order to track the location and orientation of the distal portion during the insertion, the distal portion typically comprises one or more position-sensors 18. In some embodiments sensors 18 are operative by gener-

ating signals in response to external magnetic fields interacting with the sensor. Sensors of this type are provided in the Carto® system, referenced above.

**[0023]** As stated above, at the junction between elements 14 and spine 12 the elements and the spine are transverse to each other. In addition, close to the junction each element 14 comprises a region 20 which allows the element to elastically bend from its cylindrical state. Region 20 is configured to be more flexible and elastic than the remainder of element 14, which is relatively inelastic and comprises an inelastic region 21. Consequently, under a force such as that exemplified below with respect to the description of Fig. 1B, element 14 elastically bends at region 20 rather than at another section of the element. On release of the bending force, the elastic properties of region 20 cause the element to return to its cylindrical shape.

**[0024]** In order to insert distal portion 10 into the organ of the patient referred to above, typically a sheath 24 (Fig. 1B) is first inserted into the organ. Sheath 24 typically has an internal diameter up to approximately 4 mm, depending on the size of spine 12 and elements 14, so that the diameter of the sheath may be smaller than 4 mm. Distal portion 10 is then inserted into the sheath, and the diameter of the sheath constrains elements 14, by exerting a force on the elements, to bend. The flexible and elastic character of region 20 constrains the elements to bend at the region, so that distal portion 10, with elements 14 in their bent state, may traverse sheath 24. If sheath 24 has been inserted into the patient so that a sheath distal end 26 terminates at the patient's organ, then distal portion 10 traverses the sheath until it exits the sheath, and enters the organ. On exiting the sheath elements 14 recover their cylindrical form, by unbending at elastic region 20.

**[0025]** Fig. 1B illustrates the case of catheter distal portion 10 being withdrawn, in a direction of arrow 28, from the patient's organ. In this case the catheter distal portion 10 has been withdrawn via sheath distal end 26 into sheath 24. The withdrawal exerts a force on elements 14, causing the elements to elastically bend at region 20. In contrast to the situation where the catheter distal portion is inserted into the patient's organ, Fig. 1B illustrates the case where the catheter distal portion is being withdrawn from the organ, so that bent elements 14 typically "face towards" sheath distal end 26. As is illustrated in the figure, within the sheath inelastic region 21 is parallel to spine 12. In the case of catheter distal portion 10 entering into the patient's organ, elements 14 typically "face away from" sheath distal end 26.

**[0026]** Figs. 2A and 2B illustrate schematically a distal portion 30 of a flexible insertion tube 31 in two states, according to an alternative embodiment of the present invention. Fig. 2A illustrates distal portion 30 in an unbent state; Fig. 2B illustrates the distal portion in a bent state. Tube 31 may be used as a catheter, and is also referred to herein as catheter 31. Apart from the differences described below, the operation of distal portion 30 is gen-

erally similar to that of distal portion 10 (Figs. 1A and 1B), and elements indicated by the same reference numerals in both distal portions 10 and 30 are generally similar in construction and in operation. In contrast to distal portion 10, where elements 14 are arranged in pairs, each pair joining spine 12 at a common diameter of the spine, elements 14 in distal portion 30 are arranged in a staggered configuration along spine 12. In other words, each element 14 joins spine 12 at a unique diameter of the spine. The staggered arrangement of elements 14 in distal portion 30 may reduce the possibility of a blood clot forming at the junction, compared to the local junctions of distal portion 10.

**[0027]** In some embodiments elements 14 have approximately the same dimensions and numbers of electrodes, and in the unbent state of distal portions 10 and 30 the elements are in a common flat plane defined by spine 12, when the spine is a straight line. However, other embodiments of the present invention may have elements 14 differing from each other in dimensions, and/or may have differing numbers of electrodes 16 in each element 14, and/or may lie in more than one plane defined by spine 12.

**[0028]** Fig. 3 illustrates schematically a distal portion 40 of a flexible insertion tube 41 once it has exited sheath distal end 26, according to an embodiment of the present invention. For simplicity sheath 26 is not shown in Fig. 3. Tube 41 may be used as a catheter, and is also referred to herein as catheter 41. Apart from the differences described below, the operation of distal portion 40 is generally similar to that of distal portion 10 (Figs. 1A and 1B), and elements indicated by the same reference numerals in both distal portions 10 and 40 are generally similar in construction and in operation.

**[0029]** In contrast to distal portion 10, spine 12 of distal portion 40 in its relaxed state, i.e., when it is outside sheath 26, is in the form of a section of a circle, or other plane curved structure, so that catheter 41 may be in the form of a lasso catheter, available in the Carto® system, referenced above. By way of example, spine 12 and branches 14 are assumed to lie in a common plane, the plane of the paper.

**[0030]** Fig. 4 illustrates schematically a distal portion 50 of a flexible insertion tube 51 once it has exited sheath distal end 26, according to an alternative embodiment of the present invention. For simplicity sheath 26 is not shown in Fig. 4. Tube 51 may be used as a catheter, and is also referred to herein as catheter 51. Apart from the differences described below, the operation of distal portion 50 is generally similar to that of distal portion 40 (Fig. 3), and elements indicated by the same reference numerals in both distal portions 40 and 50 are generally similar in construction and in operation.

**[0031]** As for distal portion 40, spine 12 of distal portion 50 forms a plane curved figure in its relaxed state. However, in contrast to distal portion 40, branches 14 and spine 12 of distal portion 50 do not lie in a common plane, but rather lie in different planes. In one embodiment, at

least some of branches 14 are orthogonal to the plane of spine 12 in its relaxed state.

**[0032]** There are a number of possible structures for spine 12. For example, the shape of spine 12, and typically distal portion 10 or 30, may be configured to be variable by incorporating one or more wires into the spine, the wires terminating in a shape control at the proximal end of the catheter. Such a variably shaped catheter is available in the Carto® system, referenced above. Other possible structures for spine 12 will be apparent to those having ordinary skill in the art, and all such structures are assumed to be included in the scope of the present invention.

**[0033]** Reference is now made to Fig. 5, which is a schematic illustration of a medical procedure system 60 using catheter 11 or catheter 31, according to an embodiment of the present invention. For clarity, Fig. 3 has been drawn assuming that catheter 11 is used in a diagnostic medical procedure on a heart 64 of a patient 66. Those having ordinary skill in the art will be able to adapt the following description, *mutatis mutandis*, for the case of catheter 31 being used in a, medical procedure that is not diagnostic.

**[0034]** The following description assumes that electrodes 16 and/or 22 of catheter 11 sense intra-cardiac ECG (electrocardiograph) signals from heart 64. Alternatively or additionally, at least some of the electrodes may be configured to ablate tissue of the heart. The signal sensing and/or ablation is performed after insertion of distal portion 10 into the heart by a medical professional 70.

**[0035]** System 60 may be controlled by a system processor 74, comprising a processing unit 76 communicating with an ECG module 78 and an ablation module 80. The modules enable the processing unit to provide the ECG and ablation functionality described above, as well as other functionality such as analysis and collation of results. Processor 74 may be mounted in a console 84, which comprises operating controls which typically include a pointing device such as a mouse or trackball. Professional 74 uses the pointing device to interact with the processor, which, *inter alia*, may be used to present results produced by system 60 to the professional on a screen 86.

**[0036]** Processor 74 uses software stored in a memory of the processor to operate system 60. The software may be downloaded to processor 74 in electronic form, over a network, for example, or it may, alternatively or additionally, be provided and/or stored on non-transitory tangible media, such as magnetic, optical, or electronic memory.

**[0037]** Processor 74 typically comprises other modules, such as a probe tracking module that may be coupled to position sensors 18, and a force module that measures a force on distal portion 10. For simplicity, such modules are not shown in Fig. 1. The Carto® system referenced above uses such modules.

**[0038]** It will be appreciated that the embodiments de-

scribed above are cited by way of example, and that the present invention is not limited to what has been particularly shown and described hereinabove. Rather, the scope of the present invention includes both combinations and subcombinations of the various features described hereinabove, as well as variations and modifications thereof which would occur to persons skilled in the art upon reading the foregoing description and which are not disclosed in the prior art.

#### Aspects of the invention:

#### **[0039]**

Aspect 1. A method, comprising:

providing a flexible insertion tube, having a distal segment that is configured to be inserted into a body organ;

connecting a plurality of elastic branches to the distal segment of the insertion tube at different, respective locations so that the branches extend transversely away from the insertion tube at the respective locations;

disposing one or more respective electrodes on each of the elastic branches; and  
arranging conductors to traverse the elastic branches so as to couple the electrodes to the insertion tube.

Aspect 2. The method according to aspect 1, wherein the body organ comprises a heart, the method further comprising the one or more respective electrodes acquiring an electrocardiograph (ECG) signal from the heart.

Aspect 3. The method according to aspect 1, wherein the body organ comprises a heart, the method further comprising the one or more respective electrodes being configured to ablate tissue of the heart.

#### **Claims**

1. Apparatus, comprising:

a flexible insertion tube, having a distal segment that is configured to be inserted into a body organ;

a plurality of elastic branches connected to the distal segment of the insertion tube at different, respective locations and extending transversely away from the insertion tube at the respective locations;

one or more respective electrodes disposed on each of the elastic branches; and  
conductors traversing the elastic branches so as to couple the electrodes to the insertion tube.

2. The apparatus according to claim 1, wherein each of the elastic branches comprises an elastic region and an inelastic region.
3. The apparatus according to claim 2, wherein the elastic region is closer to the flexible insertion tube than the inelastic region. 5
4. The apparatus according to claim 2, wherein on application of a bending force to the each branch, the inelastic region aligns to be parallel to the insertion tube. 10
5. The apparatus according to claim 4, wherein on removal of the bending force the inelastic region returns to extending transversely away from the insertion tube. 15
6. The apparatus according to claim 1, wherein the body organ comprises a heart, and wherein the one or more respective electrodes are configured to acquire an electrocardiograph (ECG) signal from the heart. 20
7. The apparatus according to claim 1, wherein the body organ comprises a heart, and wherein the one or more respective electrodes are configured to ablate tissue of the heart. 25
8. A method, comprising: 30
- providing a flexible insertion tube, having a distal segment that is configured to be inserted into a body organ;
- connecting a plurality of elastic branches to the distal segment of the insertion tube at different, respective locations so that the branches extend transversely away from the insertion tube at the respective locations; 35
- disposing one or more respective electrodes on each of the elastic branches; and 40
- arranging conductors to traverse the elastic branches so as to couple the electrodes to the insertion tube. 45
9. The method according to claim 8, wherein each of the elastic branches comprises an elastic region and an inelastic region.
10. The method according to claim 8, wherein on application of a bending force to the each branch, the inelastic region aligns to be parallel to the insertion tube. 50
11. The apparatus according to claim 1 or the method according to claim 8, wherein the different respective locations of a pair of the elastic branches lie on a cross-sectional circle of the flexible insertion tube. 55
12. The apparatus according to claim 1 or the method according to claim 8, wherein for a cross-sectional circle of the flexible insertion tube only one of the elastic branches is connected to the circle.
13. The apparatus according to claim 1 or the method according to claim 8, wherein the elastic branches and the distal segment lie in a common flat plane, or lie in a plurality of planes.
14. The apparatus according to claim 1 or the method according to claim 8, wherein the elastic branches are orthogonal to the distal segment, or extend non-orthogonally from the distal segment.
15. The apparatus according to claim 1 or the method according to claim 8, wherein the distal segment in a relaxed state forms a straight line, or forms a curve.





FIG. 2A

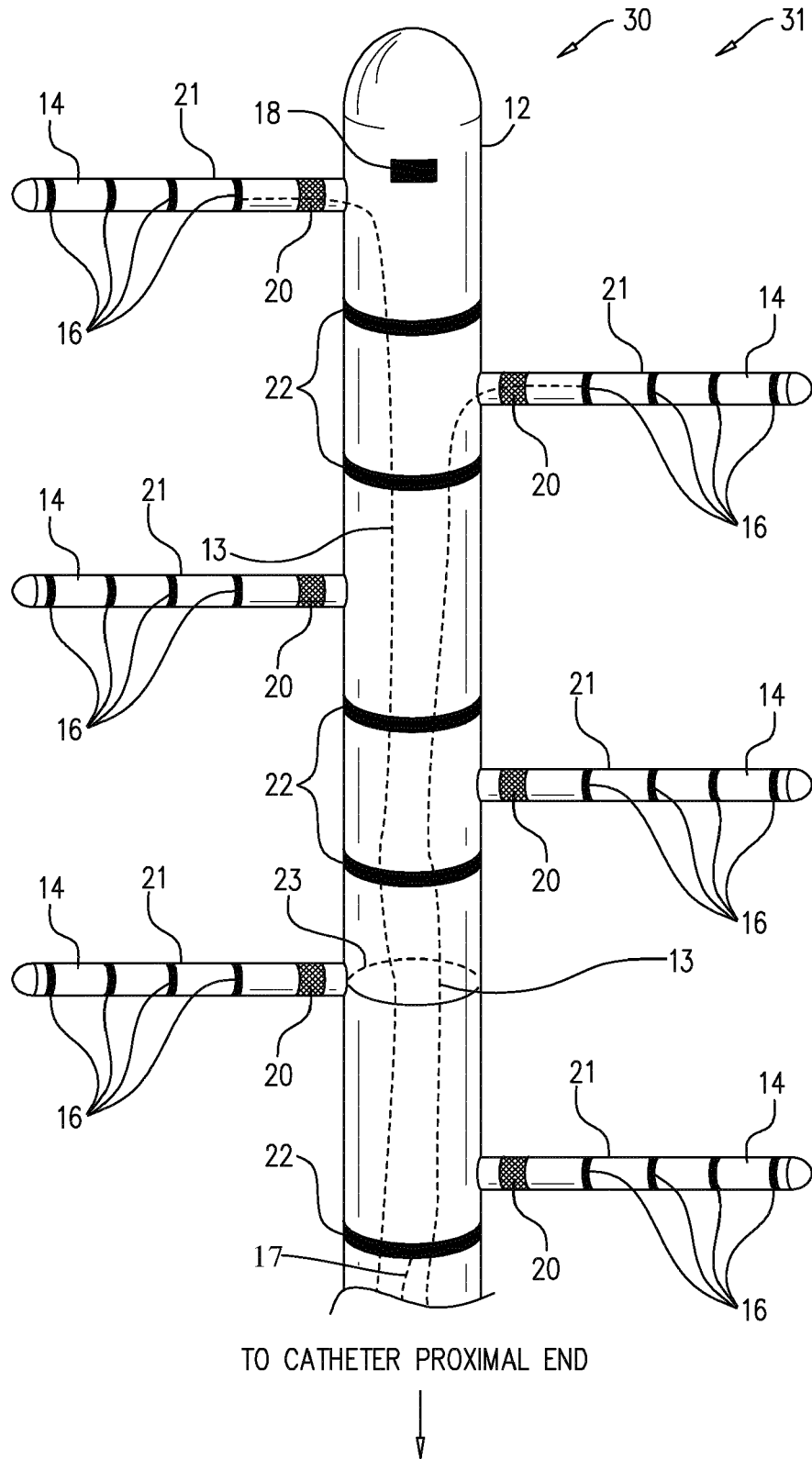

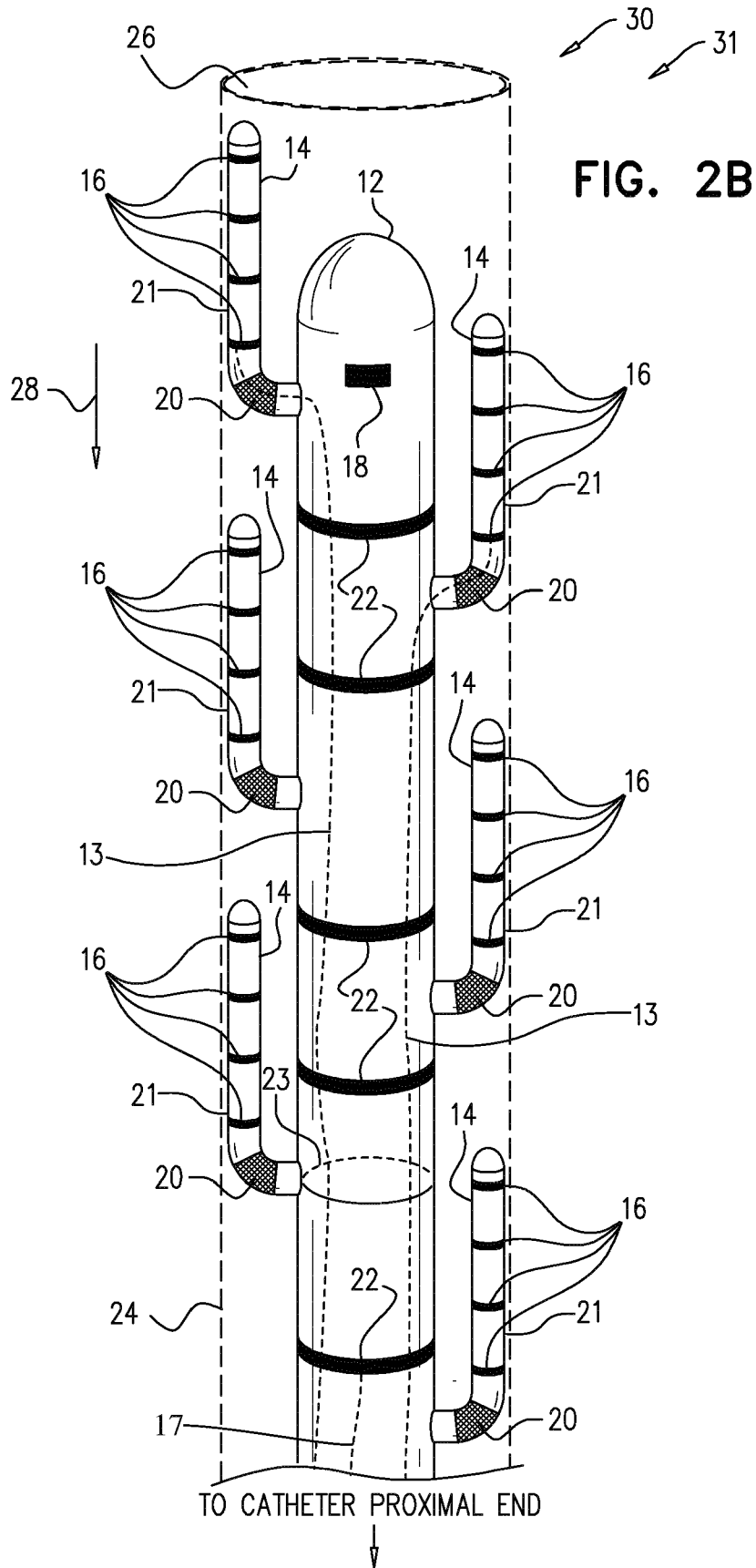

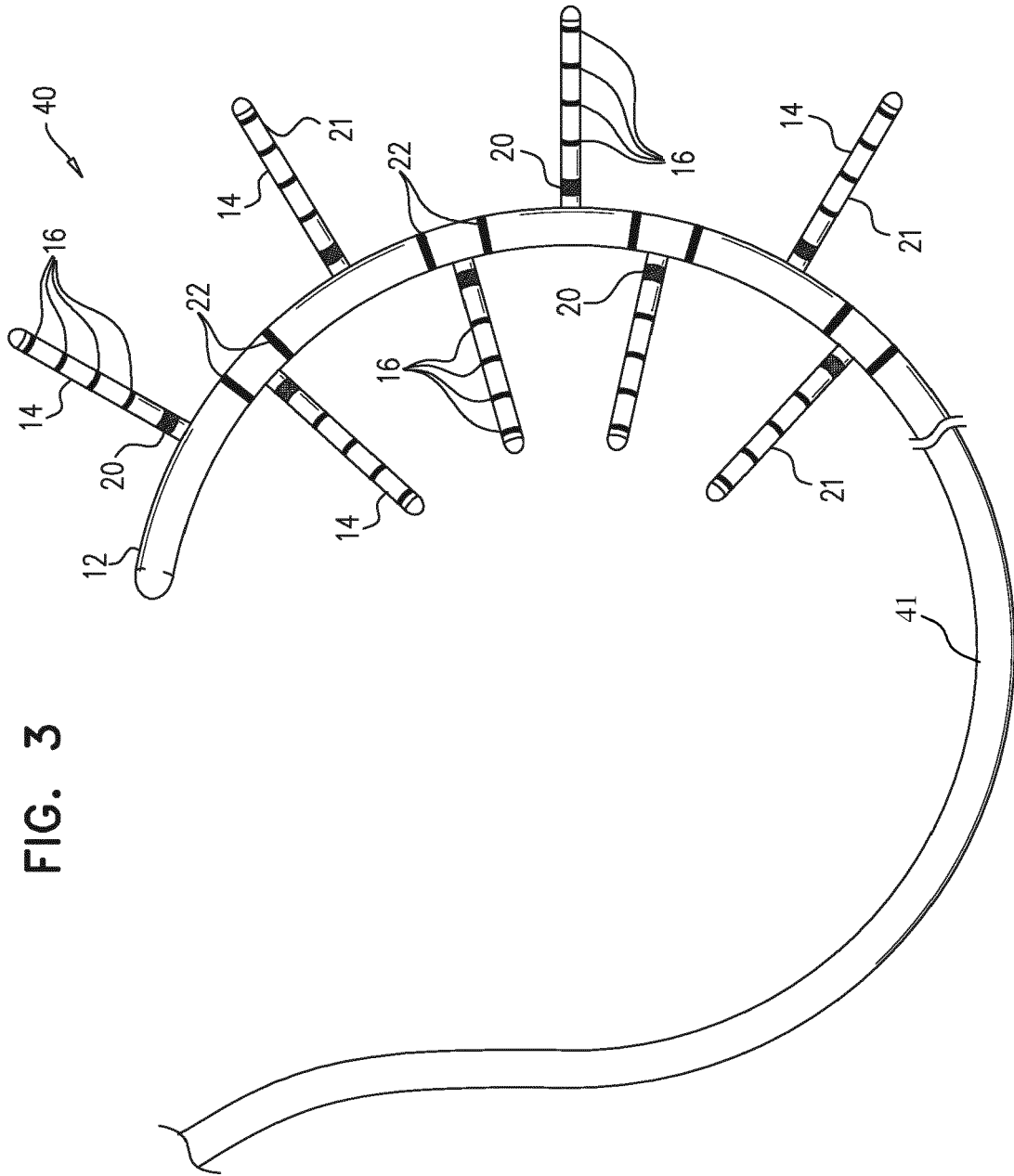

FIG. 3

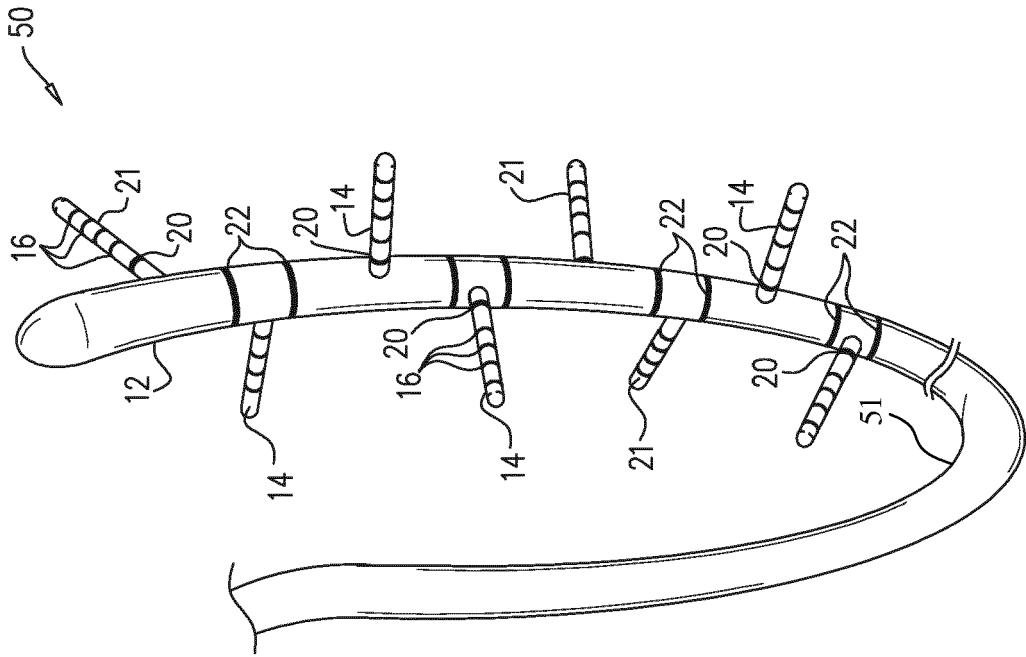
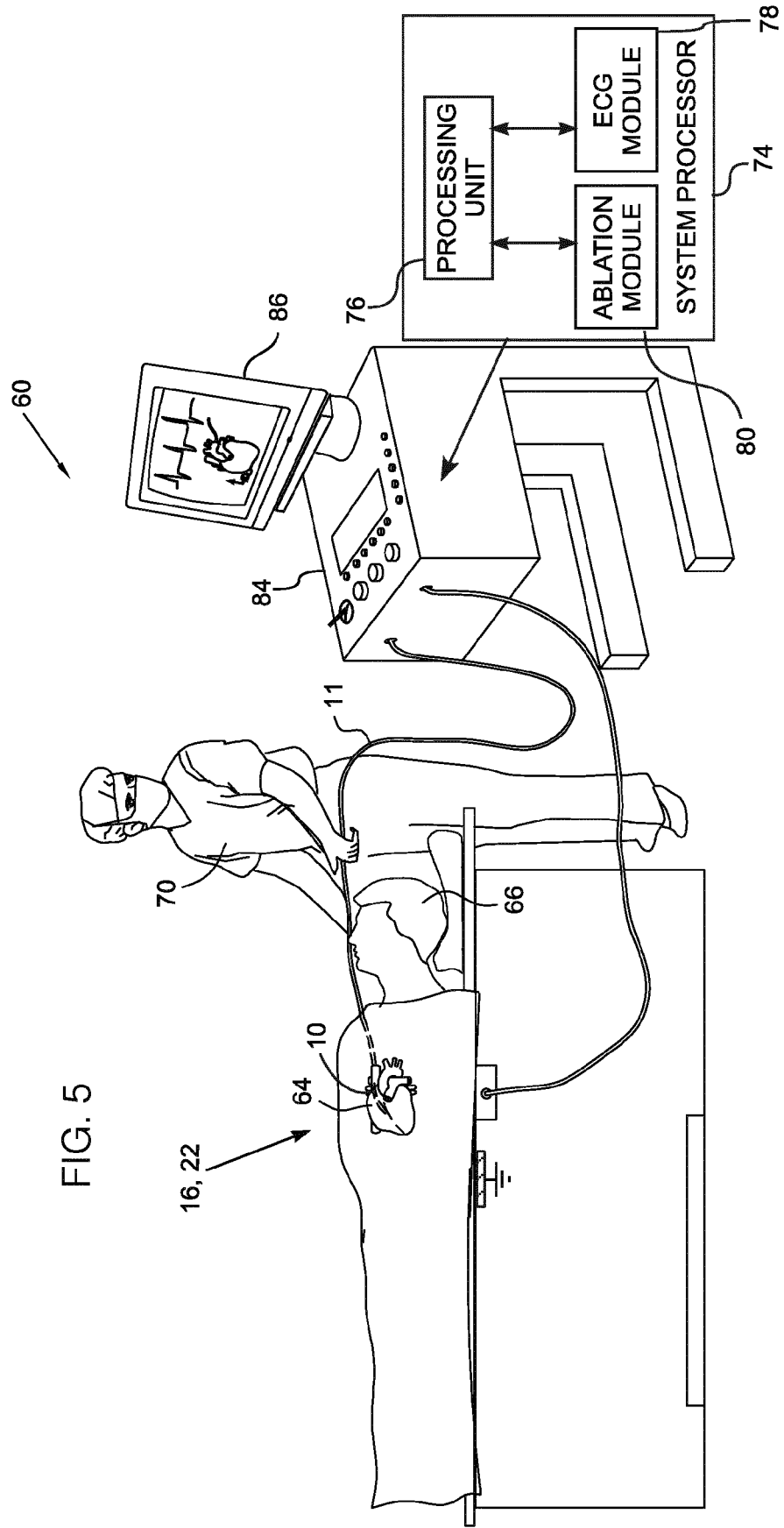

FIG. 4





EUROPEAN SEARCH REPORT

Application Number  
EP 18 18 7012

5

10

15

20

25

30

35

40

45

50

55

DOCUMENTS CONSIDERED TO BE RELEVANT			
Category	Citation of document with indication, where appropriate, of relevant passages	Relevant to claim	CLASSIFICATION OF THE APPLICATION (IPC)
X	US 6 029 091 A (DE LA RAMA ALAN [US] ET AL) 22 February 2000 (2000-02-22) * abstract; figures 1-7 * * column 1, lines 5-11 * * column 2, lines 25-39, 50-58 * * column 3, lines 8-11, 16-21, 40-43 * * column 4, line 52 - column 5, line 38 * * column 6, lines 9-18 *	1-11, 13-15	INV. A61B18/00 A61B18/14 A61B5/00
A	EP 2 641 556 A1 (BIOSENSE WEBSTER ISRAEL LTD [IL]) 25 September 2013 (2013-09-25) * abstract; figures 1-4, 6, 12, 13 * * paragraphs [0001], [0010] - [0013], [0035], [0038], [0039], [0042], [0051], [0059], [0061], [0074] *	1-11, 13-15	
A	EP 0 727 183 A1 (SORIN BIOMEDICA SPA [IT] SORIN BIOMEDICA CARDIO SPA [IT]) 21 August 1996 (1996-08-21) * abstract; figures 1,2,6,7 * * column 1, lines 3-4 * * column 2, lines 31-40 * * column 3, lines 18-31 * * column 3, line 50 - column 4, line 26 * * column 5, lines 24-52 * * column 6, lines 9-22, 44-49, 50-59 *	1,5-8, 12-15	
			TECHNICAL FIELDS SEARCHED (IPC)
			A61B
The present search report has been drawn up for all claims			
Place of search The Hague		Date of completion of the search 31 October 2018	Examiner Moualed, Laura
CATEGORY OF CITED DOCUMENTS X : particularly relevant if taken alone Y : particularly relevant if combined with another document of the same category A : technological background O : non-written disclosure P : intermediate document		T : theory or principle underlying the invention E : earlier patent document, but published on, or after the filing date D : document cited in the application L : document cited for other reasons ..... & : member of the same patent family, corresponding document	

EPO FORM 1503 03.82 (P04C01)

ANNEX TO THE EUROPEAN SEARCH REPORT  
ON EUROPEAN PATENT APPLICATION NO.

EP 18 18 7012

5

This annex lists the patent family members relating to the patent documents cited in the above-mentioned European search report. The members are as contained in the European Patent Office EDP file on The European Patent Office is in no way liable for these particulars which are merely given for the purpose of information.

31-10-2018

10

Patent document cited in search report	Publication date	Patent family member(s)	Publication date
US 6029091	A	22-02-2000	NONE
-----			
EP 2641556	A1	25-09-2013	AU 2013201681 A1 10-10-2013
			CA 2809464 A1 21-09-2013
			CN 103315806 A 25-09-2013
			EP 2641556 A1 25-09-2013
			IL 224948 A 30-04-2017
			JP 6165475 B2 19-07-2017
			JP 2013192948 A 30-09-2013
			RU 2013112613 A 27-09-2014
			US 2013253504 A1 26-09-2013
-----			
EP 0727183	A1	21-08-1996	AT 228333 T 15-12-2002
			DE 69624958 D1 09-01-2003
			DE 69624958 T2 17-07-2003
			EP 0727183 A1 21-08-1996
			ES 2187584 T3 16-06-2003
			IT T0950099 A1 14-08-1996
-----			

15

20

25

30

35

40

45

50

55

EPO FORM P0459

For more details about this annex : see Official Journal of the European Patent Office, No. 12/82

**REFERENCES CITED IN THE DESCRIPTION**

*This list of references cited by the applicant is for the reader's convenience only. It does not form part of the European patent document. Even though great care has been taken in compiling the references, errors or omissions cannot be excluded and the EPO disclaims all liability in this regard.*

**Patent documents cited in the description**

- US 6193883 A [0001]

专利名称(译)	导管有横向分支		
公开(公告)号	<a href="#">EP3420991A1</a>	公开(公告)日	2019-01-02
申请号	EP2018187012	申请日	2015-02-11
[标]申请(专利权)人(译)	韦伯斯特生物官能(以色列)有限公司		
申请(专利权)人(译)	生物传感韦伯斯特 (以色列) LTD.		
当前申请(专利权)人(译)	生物传感韦伯斯特 (以色列) LTD.		
[标]发明人	ZINO ELIAHU IGRA NOAM AUERBACH SHMUEL URMAN ROY ZRIHAM YANIV BEN PRESSMAN ASSAF		
发明人	ZINO, ELIAHU IGRA, NOAM AUERBACH, SHMUEL URMAN, ROY ZRIHAM, YANIV BEN PRESSMAN, ASSAF		
IPC分类号	A61B18/00 A61B18/14 A61B5/00		
CPC分类号	A61B5/0422 A61B5/6859 A61B18/1492 A61B2017/00044 A61B2017/00053 A61B2018/0016 A61B2018/00214 A61B2018/00351 A61B2018/00839 A61B2034/2051 A61B2562/125 Y10T29/49169 A61B2018/00577		
优先权	14/603415 2015-01-23 US 61/938883 2014-02-12 US		
其他公开文献	EP3420991B1		
外部链接	<a href="#">Espacenet</a>		

摘要(译)

装置，包括柔性插入管，具有远端段，该远端段构造成插入身体器官中。多个弹性分支在不同的相应位置处连接到插入管的远侧段，并且在相应位置处横向地远离插入管延伸。在每个弹性分支上设置有一个或多个相应的电极，并且有穿过弹性分支的导体，以便将电极连接到插入管。

