

(19)



(11)

**EP 3 151 773 B1**

(12)

**EUROPEAN PATENT SPECIFICATION**

(45) Date of publication and mention of the grant of the patent:

**04.04.2018 Bulletin 2018/14**

(51) Int Cl.:

**A61B 18/14** <sup>(2006.01)</sup>      **A61B 5/00** <sup>(2006.01)</sup>  
**A61B 5/0402** <sup>(2006.01)</sup>      **A61B 5/042** <sup>(2006.01)</sup>  
**A61B 17/00** <sup>(2006.01)</sup>      **A61B 18/00** <sup>(2006.01)</sup>

(21) Application number: **15736071.0**

(86) International application number:

**PCT/US2015/032753**

(22) Date of filing: **27.05.2015**

(87) International publication number:

**WO 2015/187430 (10.12.2015 Gazette 2015/49)**

(54) **ELECTRODE ASSEMBLY**

ELEKTRODENANORDNUNG

ENSEMBLE ÉLECTRODE

(84) Designated Contracting States:

**AL AT BE BG CH CY CZ DE DK EE ES FI FR GB GR HR HU IE IS IT LI LT LU LV MC MK MT NL NO PL PT RO RS SE SI SK SM TR**

- **HULTZ, Paul**  
Brookline, New Hampshire 03033 (US)
- **KOZLOWSKI, Michael C.**  
Reading, Massachusetts 01867 (US)
- **STEWART, Brian**  
North Reading, Massachusetts 01864 (US)

(30) Priority: **04.06.2014 US 201462007716 P**

(43) Date of publication of application:

**12.04.2017 Bulletin 2017/15**

(74) Representative: **Pfenning, Meinig & Partner mbB**

**Patent- und Rechtsanwälte  
Joachimsthaler Straße 10-12  
10719 Berlin (DE)**

(73) Proprietor: **Boston Scientific Scimed, Inc.**  
**Maple Grove, MN 55311 (US)**

(56) References cited:

**EP-A1- 2 269 505**      **WO-A1-97/25917**  
**WO-A1-2014/110579**      **US-A1- 2009 299 355**  
**US-A1- 2012 271 135**      **US-A1- 2014 018 880**

(72) Inventors:

- **MARECKI, Andrew T.**  
Shrewsbury, Massachusetts 01545 (US)

**EP 3 151 773 B1**

Note: Within nine months of the publication of the mention of the grant of the European patent in the European Patent Bulletin, any person may give notice to the European Patent Office of opposition to that patent, in accordance with the Implementing Regulations. Notice of opposition shall not be deemed to have been filed until the opposition fee has been paid. (Art. 99(1) European Patent Convention).

## Description

### TECHNICAL FIELD

**[0001]** The present disclosure generally relates to catheters and electrode assemblies for use in cardiac procedures and more particularly, to an electrode assembly that may be utilized in a cardiac mapping procedure.

### BACKGROUND

**[0002]** Mapping the electrical activity of the heart is a critical component for the diagnosis and treatment of heart disease. Many advanced therapies (such as ablation for the treatment of arrhythmias) require detailed electroanatomic mapping. Currently, mapping is performed in an electrophysiology (EP) lab, during which mapping catheters are inserted into the heart and carefully moved to various locations around the heart to map and identify the origins of the arrhythmia. Once the origin of the arrhythmia is identified, the specific tissue may be destroyed by ablation.

**[0003]** Document EP 2 269 505 A1 discloses an electrophysiology catheter including an elongate catheter body having an elastically-deformable distal region predisposed to assume a spiral shape and a first plurality of electrodes disposed thereon. Each of the first plurality of electrodes includes an electrically active region limited to the inner surface of the spiral shape for use in non-contact electrophysiology studies. A second plurality of electrodes may also be disposed on the distal region interspersed (e.g., alternating) with the first plurality of electrodes, with each of the second plurality of electrodes having an electrically active region extending into the outer surface of the spiral shape for use in contact electrophysiology studies. The distal region may be reformed into a straight configuration for insertion into and navigation through the patient's vasculature, for example via use of a tubular introducer. As the distal region deploys beyond the distal end of the introducer, it resumes the spiral shape.

**[0004]** Document US 2009/0299355 A1 is related to a method of ablating body tissue includes (a) locating an inflatable balloon portion of a cryotherapy balloon catheter at a treatment site interval to a patient's body, and inflating the inflatable balloon portion; (b) employing electrodes that are disposed on an expandable surface of the inflatable balloon portion to electrically characterize body tissue at the treatment site; (c) ablating the body tissue by supplying a cryotherapy agent to the inflatable balloon portion to cool the body tissue to a therapeutic temperature; (d) employing the electrodes to determine whether the ablating caused desired electrical changes in the body tissue; and (e) repeating (c) and (d) when it is determined that the ablating did not cause the desired electrical changes.

**[0005]** Document WO 97/25917 discloses systems and methods for heating body tissue places a multi-func-

tion structure having an exterior wall in contact with body tissue. The structure includes an array of electrically conducting electrode segments carried by the exterior wall. An electrically conductive network is coupled to the electrode segments, including at least one electrically conductive path (32) individually coupled to each electrode segment. The systems and methods operate in a first mode during which the network is electrically conditioned to individually sense at each electrode segment local electrical events in tissue, such as electrical potentials, resistivity, or impedance. The systems and methods operate in a second mode during which the network is electrically conditioned, based at least in part upon local electrical events sensed by the electrode segments, to couple at least two electrode segments together to simultaneously transmit electrical energy to heat or ablate a region of body tissue.

**[0006]** Document WO 2014/110479 A1 discloses medical devices for ablating nerves perivascularly and methods for making and using the same. An example medical device may include an expandable frame slidably disposed within a catheter shaft. The expandable frame may be configured to shift between a collapsed configuration and an expanded configuration. One or more electrodes may be disposed on a surface of the expandable frame. The one or more electrodes may be disposed radially inward relative to the greatest radial extent of the expandable frame when the expandable frame is in the expanded configuration.

**[0007]** Document US 2014/018880 A1 is related to methods and apparatus for monopolar neuromodulation, e.g., via a pulsed electric field. Such monopolar neuromodulation may effectuate irreversible electroporation or electrofusion, necrosis and/or inducement of apoptosis, alteration of gene expression, action potential attenuation or blockade, changes in cytokine up-regulation and other conditions in target neural fibers. In some embodiments, monopolar neuromodulation is applied to neural fibers that contribute to renal function. In some embodiments, such monopolar neuromodulation is performed bilaterally.

### SUMMARY

**[0008]** The present disclosure generally relates to catheter and electrode assemblies for use in cardiac procedures and more particularly, to an electrode assembly that may be utilized in a cardiac mapping procedure.

**[0009]** In one example, a catheter includes: an elongate catheter body extending from a proximal end to a distal end; and an expandable electrode assembly disposed at the distal end of the catheter body, the electrode assembly configured to transition from a collapsed configuration to an expanded configuration and comprising at least one flexible member having an outer surface and an inner surface, wherein the at least one flexible member comprises a first electrode disposed on the outer surface of the flexible member and a second electrode disposed

on the inner surface of the flexible member.

**[0010]** In addition or alternatively to any one or more of the above, and in another example, the first and second electrodes are configured to form a bipolar electrode pair.

**[0011]** In addition or alternatively to any one or more of the above, and in another example, the first electrode is located directly opposite the second electrode.

**[0012]** In addition or alternatively to any one or more of the above, and in another example, the first electrode is offset from the second electrode.

**[0013]** In addition or alternatively to any one or more of the above, and in another example, the flexible member comprises at least one flexible printed circuit.

**[0014]** In addition or alternatively to any one or more of the above, and in another example, the flexible member comprises a single, dual sided flexible printed circuit wherein the first electrode is formed on an outer surface of the flexible printed circuit and the second electrodes is formed on an inner surface of the flexible printed circuit.

**[0015]** In addition or alternatively to any one or more of the above, and in another example, the flexible member comprises a first flexible printed circuit defining the first electrode formed on an upper surface of a substrate and a second flexible printed circuit defining the second electrode formed on a lower surface of the substrate.

**[0016]** In addition or alternatively to any one or more of the above, and in another example, a distance between the first electrode and the second electrode is less than about 0.5 mm.

**[0017]** In addition or alternatively to any one or more of the above, and in another example, the flexible member comprises multiple bipolar electrode pairs defined by a first electrode disposed on the outer surface of the flexible member and a second electrode disposed on the inner surface of the flexible member.

**[0018]** In addition or alternatively to any one or more of the above, and in another example, further comprising two or more flexible members, each of the two or more flexible members comprising at least a first electrode disposed on the outer surface of the flexible member and at least a second electrode disposed on the inner surface of the flexible member.

**[0019]** In addition or alternatively to any one or more of the above, and in another example, wherein the first and second electrodes form a bipolar electrode pair across the outer and inner surface of the flexible member.

**[0020]** In another example, a method of forming a flexible electrode assembly includes: forming a flexible electrode assembly comprising at least one flexible member having an outer surface and an inner surface, wherein the at least one flexible member comprises a first electrode disposed on the outer surface of the flexible member and a second electrode disposed on the inner surface of the flexible member and wherein the flexible electrode assembly is configured to transition from a collapsed configuration to an expanded configuration; and coupling the flexible electrode assembly to a distal end of an elongate catheter body.

**[0021]** In addition or alternatively to any one or more of the above, and in another example, the method further includes: forming a flexible layered sheet comprising at least one flexible printed circuit defining a first electrode on an outer surface of the flexible layered sheet and a second electrode on an inner surface of the flexible layered sheet; separating the flexible layered sheet into two or more flexible members, each flexible member having a first electrode located on an outer surface and a second electrode located on an inner surface; and forming an expandable electrode assembly from at least one of the flexible members.

**[0022]** In addition or alternatively to any one or more of the above, and in another example, the method further includes forming an expandable electrode assembly from two or more flexible members by joining the two or more flexible members together at a first end of each of the two or more flexible members.

**[0023]** In addition or alternatively to any one or more of the above, and in another example, the method further includes joining the two or more flexible members together at a second end of each of the two or more flexible members.

**[0024]** In another example, a catheter includes an elongate catheter body extending from a proximal end to a distal end; and an expandable electrode assembly disposed at the distal end of the catheter body, the electrode assembly configured to transition from a collapsed configuration to an expanded configuration and comprising at least one flexible member having an outer surface and an inner surface, wherein the at least one flexible member comprises a first electrode disposed on the outer surface of the flexible member and a second electrode disposed on the inner surface of the flexible member.

**[0025]** In addition or alternatively to any one or more of the above, and in another example, the first and second electrodes are configured to form a bipolar electrode pair.

**[0026]** In addition or alternatively to any one or more of the above, and in another example, the first electrode is located directly opposite the second electrode.

**[0027]** In addition or alternatively to any one or more of the above, and in another example, the first electrode is offset from the second electrode.

**[0028]** In addition or alternatively to any one or more of the above, and in another example, the catheter further includes two or more flexible members, each of the two or more flexible members comprising at least a first electrode disposed on the outer surface of the flexible member and at least a second electrode disposed on the inner surface of the flexible member.

**[0029]** In addition or alternatively to any one or more of the above, and in another example, the flexible member comprises at least one flexible printed circuit.

**[0030]** In addition or alternatively to any one or more of the above, and in another example, the flexible member comprises a single, dual sided flexible printed circuit wherein the first electrode is formed on an outer surface of the flexible printed circuit and the second electrodes

is formed on an inner surface of the flexible printed circuit.

**[0031]** In addition or alternatively to any one or more of the above, and in another example, the flexible member comprises a first flexible printed circuit defining the first electrode formed on an upper surface of a substrate and a second flexible printed circuit defining the second electrode formed on a lower surface of the substrate.

**[0032]** In addition or alternatively to any one or more of the above, and in another example, a distance between the first electrode and the second electrode is less than about 0.5 mm.

**[0033]** In addition or alternatively to any one or more of the above, and in another example, the flexible member comprises multiple bipolar electrode pairs defined by a first electrode disposed on the outer surface of a flexible member and a second electrode disposed on the inner surface each of the flexible member.

**[0034]** In another example, a catheter includes: an elongate catheter body extending from a proximal end to a distal end; and an expandable electrode assembly disposed at the distal end of the catheter body, the electrode assembly configured to transition from a collapsed configuration to an expanded configuration and comprising two or more flexible splines having an outer surface and an inner surface, wherein at least one of the two or more flexible splines comprises at least a first electrode disposed on the outer surface of the flexible spline and at least a second electrode disposed on the inner surface of the flexible spline.

**[0035]** In addition or alternatively to any one or more of the above, and in another example, the first and second electrodes are configured to form a bipolar electrode pair.

**[0036]** In addition or alternatively to any one or more of the above, and in another example, the first electrode is located directly opposite the second electrode.

**[0037]** In addition or alternatively to any one or more of the above, and in another example, the first electrode is offset from the second electrode.

**[0038]** In addition or alternatively to any one or more of the above, and in another example, each of the two or more splines comprises multiple bipolar electrode pairs defined by a first electrode disposed on the outer surface of a flexible spline and a second electrode disposed on the inner surface of the flexible spline.

**[0039]** In addition or alternatively to any one or more of the above, and in another example, each of the two or more flexible splines comprises at least one flexible printed circuit.

**[0040]** In addition or alternatively to any one or more of the above, and in another example, the at least one flexible circuit is a single, dual sided flexible printed circuit having a first electrode is formed on an upper surface of the flexible printed circuit and a second electrode formed on a lower surface of the flexible printed circuit.

**[0041]** In addition or alternatively to any one or more of the above, and in another example, each of the two or more flexible splines comprises a first flexible printed circuit defining a first electrode formed on an upper surface

of a substrate and a second flexible printed circuit defining a second electrode formed on a lower surface of the substrate.

**[0042]** In yet another example, a method of forming a flexible electrode assembly includes: forming a flexible electrode assembly comprising at least one flexible member having an outer surface and an inner surface, wherein the at least one flexible member comprises a first electrode disposed on the outer surface of the flexible member and a second electrode disposed on the inner surface of the flexible member and wherein the flexible electrode assembly is configured to transition from a collapsed configuration to an expanded configuration; and coupling the flexible electrode assembly to a distal end of an elongate catheter body.

**[0043]** In addition or alternatively to any one or more of the above, and in another example, the method further includes forming a flexible layered sheet comprising at least one flexible printed circuit defining a first electrode on an outer surface of the flexible layered sheet and a second electrode on an inner surface of the flexible layered sheet; separating the flexible layered sheet into two or more flexible members, each flexible member having a first electrode located on an outer surface and a second electrode located on an inner surface; and forming the expandable electrode assembly from at least one of the flexible members.

**[0044]** In addition or alternatively to any one or more of the above, and in another example, the method further includes forming an expandable electrode assembly from two or more flexible members by joining the two or more flexible members together at least at a first end of each of the two or more flexible member.

**[0045]** In still another example, a method of forming a flexible electrode assembly is disclosed. The method includes: forming a first flexible printed circuit comprising one or more electrodes on an upper surface of a substrate and forming a second flexible printed circuit comprising one or more electrodes on a lower surface of the substrate to produce a flexible layered sheet; separating the flexible layered sheet into two or more splines extending longitudinally from a proximal end of the flexible layered sheet to a distal end of the flexible layered sheet, wherein the two or more splines are fully separated from one another such that they are not connected and wherein each of the two or more splines comprises at least one bipolar electrode pair defined by a first electrode from the first flexible printed circuit disposed on the upper surface of the substrate and a second electrode from the second flexible printed circuit disposed on the lower surface of the substrate, each electrode located on opposite sides of each of the two or more splines; mechanically joining the fully separated two or more flexible splines together to form an expandable electrode assembly.

**[0046]** In addition or alternatively to any one or more of the above, the substrate comprises Nitinol.

**[0047]** In addition or alternatively to any one or more of the above, the step of separating the flexible layered

sheet into two or more splines comprises laser cutting the flexible layered sheet into two or more splines.

**[0048]** In addition or alternatively to any one or more of the above, the step of separating the flexible layered sheet into two or more splines comprises die cutting the flexible layered sheet into two or more splines.

**[0049]** In addition or alternatively to any one or more of the above, the method further includes securing a second end of the first spline and a second end of the second spline to a distal end of a catheter body.

**[0050]** In addition or alternatively to any one or more of the above, wherein the fully separated splines are mechanically joined together by inserting their respective distal ends into corresponding slots provided in a distal cap.

**[0051]** The above summary of some embodiments is not intended to describe each disclosed embodiment or every implementation of the present disclosure. The Figures, and Detailed Description, which follow, more particularly exemplify these embodiments.

#### BRIEF DESCRIPTION OF THE DRAWINGS

**[0052]** The disclosure may be more completely understood in consideration of the following detailed description of various embodiments in connection with the accompanying drawings, in which:

Figure 1 is a schematic diagram showing a catheter in the context of a system;

Figures 2A-2B are schematic views of an exemplary catheter that may be utilized in the system shown in Figure 1;

Figures 3A-3G are schematic views of exemplary expandable electrode assemblies;

Figure 4A is an isometric view of an expandable electrode assembly shown in a collapsed configuration; Figure 4B is an isometric view of the expandable electrode assembly of Figure 4A shown in an expanded configuration;

Figure 4C is a close-up, isometric view of the expandable electrode assembly of Figure 4B in the expanded configuration;

Figure 4D is a top plan view of the expandable electrode assembly shown in Figures 4B and 4C in the expanded configuration;

Figures 5A and 5B are close-up schematic views of exemplary individual splines of an expandable electrode assembly including multiple bipolar electrode pairs;

Figure 6 is a side, cross-sectional view of an exemplary multi-layered flexible sheet including at least one flexible printed circuit used to construct an expandable electrode assembly;

Figures 7A and 7B are schematic views of the inner and outer surfaces, respectively, a portion of a flexible spline incorporating a single flexible printed circuit;

Figure 8A shows a top plan view of a multi-layered flexible sheet used to construct an electrode assembly;

Figure 8B is a bottom plan view of the multi-layered flexible sheet shown in Figure 8A; and

Figures 9A-9D provide a stepwise illustration of a method of constructing the expandable electrode assembly from a multi-layered flexible sheet including at least one flexible printed circuit.

**[0053]** While the disclosure is amenable to various modifications and alternative forms, specifics thereof have been shown by way of example in the drawings and will be described in detail. It should be understood, however, that the intention is not to limit aspects of the disclosure to the particular embodiments described. On the contrary, the intention is to cover all modifications, equivalents, and alternatives falling within the spirit and scope of the disclosure.

#### DETAILED DESCRIPTION

**[0054]** The following detailed description should be read with reference to the drawings in which similar elements in different drawings are numbered the same. The detailed description and the drawings, which are not necessarily to scale, depict illustrative embodiments and are not intended to limit the scope of the disclosure. The illustrative embodiments depicted are intended only as exemplary. Selected features of any illustrative embodiment may be incorporated into an additional embodiment unless clearly stated to the contrary.

**[0055]** For the following defined terms, these definitions shall be applied, unless a different definition is given in the claims or elsewhere in this specification.

**[0056]** All numeric values are herein assumed to be modified by the term "about", whether or not explicitly indicated. The term "about" generally refers to a range of numbers that one of skill in the art would consider equivalent to the recited value (i.e., having the same function or result). In many instances, the term "about" may be indicative as including numbers that are rounded to the nearest significant figure.

**[0057]** The recitation of numerical ranges by endpoints includes all numbers within that range (e.g., 1 to 5 includes 1, 1.5, 2, 2.75, 3, 3.80, 4, and 5).

**[0058]** Although some suitable dimensions, ranges and/or values pertaining to various components, features and/or specifications are disclosed, one of skill in the art, incited by the present disclosure, would understand desired dimensions, ranges and/or values may deviate from those expressly disclosed.

**[0059]** As used in this specification and the appended claims, the singular forms "a", "an", and "the" include plural referents unless the content clearly dictates otherwise. As used in this specification and the appended claims, the term "or" is generally employed in its sense including "and/or" unless the content clearly dictates oth-

erwise.

**[0060]** Mapping the electrophysiology of heart rhythm disorders often involves the introduction of a constellation catheter or other mapping/sensing device having a plurality of electrodes and/or sensors (e.g., CONSTELLATION®, commercially available from Boston Scientific) into a cardiac chamber. The sensors detect the electric activity of the heart at sensor locations. It may be desirable to have the electric activity processed into electrogram signals that accurately represent cellular excitation through cardiac tissue relative to the sensor locations. A processing system may then analyze and output the signal to a display device. Further, the processing system may output the signal as an activation or vector field map. The physician may use the activation or vector field map to perform a diagnostic procedure.

**[0061]** Figure 1 is a high level, schematic view of an overall system 2 that includes a physician, a patient, catheters, including a mapping catheter 10, and related electrophysiology equipment located within an operating room. A physician 16 introduces the catheter 10 into the vasculature of the patient 11 at the patient's leg and advances it along a blood vessel ultimately, entering the patient's heart 12. As will be described in greater detail herein, the catheter 10 may include an electrode assembly having multiple sensing electrodes for sensing the electrical activity of the heart. Other catheters that may be used in the procedure are represented by companion catheter 18. Each catheter 10, 18 is coupled to a processing system 20 using appropriate catheter cabling typified by connection cable 17. If the companion catheter 18 is an ablation catheter, then processing system 20 also forms an interface to an RF ablation unit (not illustrated).

**[0062]** Processing system 20 may include dedicated circuitry (e.g., discrete logic elements and one or more microcontrollers; a memory or one or more memory units, application-specific integrated circuits (ASICs); and/or specially configured programmable devices, such as, for example, programmable logic devices (PLDs) or field programmable gate arrays (FPGAs)) for receiving and/or processing the acquired activation signals. In at least some embodiments, processing system 20 includes a general purpose microprocessor and/or a specialized microprocessor (e.g., a digital signal processor, or DSP, which may be optimized for processing activation signals) that executes instructions to receive, analyze and display information associated with the received activation signals. In such implementations, processing system 20 can include program instructions, which when executed, perform part of the signal processing. Program instructions can include, for example, firmware, microcode or application code that is executed by microprocessors or microcontrollers. In addition, the processing system 20 may include suitable signal conditioning circuitry including signal amplifiers, rectifiers, filters, etc. for improving the quality of the incoming activation signal. The above-mentioned implementations are merely exemplary. A variety of processing systems 20 are contemplated.

plated.

**[0063]** In some embodiments, processing system 20 may be configured to measure the electrical activity in the myocardial tissue adjacent to one or more electrodes located on the electrode assembly. For example, in some embodiments, processing system 20 may be configured to detect electrical activity associated with a dominant rotor or divergent activation pattern in the anatomical feature being mapped. Dominant rotors and/or divergent activation patterns may have a role in the initiation and maintenance of atrial fibrillation, and ablation of the rotor path, rotor core, and/or divergent foci may be effective in terminating the atrial fibrillation. In either situation, processing system 20 processes the sensed activation signals to generate a display of relevant characteristics, such as an isochronal map, activation time map, action potential duration (APD) map, a vector field map, a contour map, a reliability map, an electrogram, a cardiac action potential, and/or the like. The relevant characteristics may be used by the physician to identify a site suitable for ablation therapy.

**[0064]** In use, the physician looks at a computer display 26. Present on the display 26 is a substantial amount of information. A large window presents an image of the heart chamber 13 along with an image of the catheter 10. The physician will manipulate and control the catheter 10 based in part on the images and other data presented on the display 26. The representation of the heart chamber 13 may use color, wire frame, or other techniques to depict the structure of the heart chamber 13 and to simultaneously portray electrical activity of the patient's heart. In some cases, it may be useful to display chamber geometry, catheter location, and electrical activity in an integrated fashion on the display 26. In use, the physician will observe the display 26 and interact with the workstation 24 and the catheters 10 and 18, to direct a medical procedure such as, for example, a cardiac mapping procedure.

**[0065]** Figures 2A and 2B are schematic views of an exemplary intravascular catheter 10 that may be utilized in the context of the system 2 shown in Figure 1. The catheter 10 may be deployed at a target location within a patient's heart. The catheter 10 may be used to map electro-anatomical characteristics of the heart and/or to locate and position other catheters within the heart. Electrode stability and the known spatial geometry of the electrodes may improve the accuracy of the mapping device. In some cases, the catheter 10 may include an expandable electrode assembly 30 including one or more electrodes that may be used for cardiac mapping or diagnosis, ablation and/or other therapies involving the application of energy to a patient's heart. The expandable one or more electrodes may be located on the inner and/or outer surfaces of at least one flexible member forming the expandable electrode assembly 30.

**[0066]** As shown in Figures 2A and 2B, the catheter 10 includes an elongate catheter body 34 extending from a proximal end 38 to a distal end 42. In addition, the

catheter body 34 may include a lumen (not shown) extending there through, but this is not required in all embodiments. The catheter body 34 may have sufficient flexibility so as to navigate the tortuous pathways of a patient's vasculature system. The catheter 10 can include a handle assembly 46 coupled to the proximal end 38 of the catheter body 34. A physician may manipulate the handle assembly 46 to deliver, steer, rotate, deploy and/or deflect the catheter 10 when performing a medical procedure.

**[0067]** In some cases, the handle assembly 46 may include a first actuation mechanism 48 that may be manipulated to transition the expandable electrode assembly 30 from a collapsed configuration (shown in Figure 2A) suitable for delivery of the catheter 10 to a target location within a patient's body (e.g. the heart) and an expanded configuration (shown in Figure 2B) suitable for use in a diagnostic procedure and/or delivery of a therapy. In some cases, the actuation mechanism 48 may include a pull wire that may be coupled to the expandable electrode assembly 30 that, when actuated in a proximal direction as indicated by the arrow shown in Figure 2B, causes the expandable electrode assembly 30 to transition from the collapsed configuration to the expanded configuration. In other cases, the actuation mechanism 48 may include a retractable sheath that, when retracted in a proximal direction as indicated by the arrow shown in Figure 2B, may permit the expandable electrode assembly 30 to self-expand from the collapsed configuration to the expanded configuration. These are just some examples of exemplary actuation mechanisms that may be utilized to facilitate expansion of the expandable electrode assembly 30 when the catheter 10 is in use. In some cases, the catheter body 34

may include a deflectable distal portion 52 that a physician may manipulate using a second actuation mechanism 54 provided in the handle assembly 46 to position the electrode assembly 30 nearer or adjacent to tissue of interest.

**[0068]** As discussed herein, the expandable electrode assembly 30 may include one or more electrodes that may be used for cardiac mapping or diagnosis, ablation and/or other therapies. In use, the expandable electrode assembly 30 may be expanded and used to position the one or more electrodes adjacent and/or in contact with the target tissue of interest to measure an electrical signal. The expandable electrode assembly 30 may include at least one flexible member or spline on which the one or more electrodes may be located. In some cases, the expandable electrode assembly may include two or more flexible members as the size and geometry of the expandable electrode assembly 30 may permit. For example, the expandable electrode assembly may include four, five, six, seven, and in some cases as many as eight flexible members, but not limited to this. In some cases, the size, geometry and number of flexible members or splines may be dependent the location of the body in which the device is to be deployed to investigate the tar-

get tissue of interest. One or more electrodes 64 may be disposed on at least one of the flexible members forming the expandable electrode assembly 30. The electrodes 64 may be located on an inner surface, an outer surface or both the inner and outer surfaces of the at least one flexible member. In some cases, at least a first electrode 64 is located on an outer surface and at least a second electrode 64 is located on an inner surface of a flexible member. In many cases, the at least one flexible member 60 is substantially planar or flat. Figures 3A-3G are schematic views of exemplary expandable electrode assemblies 30a-30g including at least one flexible member 60 that may be used to support a plurality of electrodes 64 as described herein according to the various embodiments.

**[0069]** Figures 4A-4D show different views of an exemplary expandable electrode assembly 30 that may be used to support a plurality of electrodes. As shown in Figures 4A and 4B, the expandable electrode assembly 30 is capable of being transitioned from a generally collapsed configuration (Figure 4A) suitable for delivery of the catheter 10 and the electrode assembly 30 to a target location within the patient's heart and an expanded configuration (Figure 4B) suitable for use in a desired cardiac procedure such as, for example, a cardiac mapping or ablation procedure.

**[0070]** As shown in Figures 4A and 4B, the expandable electrode assembly 30 may include two or more flexible members or splines 60 which may be capable of being flexed outwardly and away from a longitudinal axis of the electrode assembly 30. In some cases, as discussed herein, an actuation mechanism may be utilized to transition the electrode assembly 30 including the two or more flexible splines 60 from the collapsed configuration (Figure 4A) to the expanded configuration (Figure 4B). In other cases, the flexible splines 60 may incorporate a shape memory material that may facilitate self-expansion of the flexible splines 60 and consequently, the electrode assembly 30, from the collapsed configuration to the expanded configuration. The flexible splines 60 may be relatively stiff such that the electrode assembly 30 may be expanded into a set of known, reproducible shapes capable of retaining a known spatial geometry when in use which, in some cases, may be aided by the incorporation of a shape-memory material or other stiff polymeric material such as, for example, a polyimide or PEEK into the flexible splines 60. Alternatively, depending upon the desired application, the flexible splines 60 may be fabricated such that they are somewhat compliant so as to conform to a surface of a patient's heart when placed into intimate contact with the patient's heart. In addition, in some cases, the flexible members or splines 60 may be fabricated such that they are substantially planar or flat.

**[0071]** The expandable electrode assembly 30 may include a number of electrodes 64 located on each of the flexible splines 60 forming an electrode array. In many cases, the electrodes 64 may be sensing electrodes. In addition, the electrode assembly 30 may include at least

some current injection locator electrodes. The electrode assembly 30 may also include a tip electrode which may be used for cardiac stimulation, ablation or as a locator electrode.

**[0072]** Each electrode 64 may be electrically connected to the cabling in the handle assembly 46. In some cases, the signal from each individual electrode 64 may be independently available at the processing system 20 (Figure 1). This may be achieved by passing a conductor for each electrode through the connection cable 17 (Figure 1).

**[0073]** The number of electrodes 64 distributed throughout the electrode assembly 30 and the stability of the shape of electrode assembly 30, when expanded, may affect the overall performance of the mapping system. In some cases, the electrodes 64 may have a uniform and symmetrical distribution throughout the expandable electrode assembly 30. In other cases, the electrodes 64 may have an asymmetrical distribution throughout the expandable electrode assembly 30 which may be advantageous for non-contact cardiac mapping procedures. An electrode assembly 30 having an asymmetrical distribution of electrodes 64 throughout the expandable electrode assembly 30 may also be useful for contact mapping.

**[0074]** The electrodes 64 may be located on the outer surfaces 66 of each of the splines 60, the inner surfaces 68 of each of the splines 60, or both the outer and inner surfaces 66, 68 of each of the flexible splines 60 as shown in Figures 4B and 4C. In some cases, up to sixty-four sensing electrodes 64 may be distributed over and along the various splines 60 including both the outer and inner surfaces 66, 68 of the splines 60. Depending upon the application, the electrode assembly 30 may include fewer or greater than sixty-four electrodes.

**[0075]** In many cases, the electrodes 64 may form at least one bipolar electrode pair. In some cases, the electrodes 64 may form multiple bipolar electrode pairs. The bipolar electrode pairs may be distributed throughout the expandable electrode assembly 30. In some cases, the bipolar electrode pairs may be formed between first and second electrodes 64 located on the same surface of a flexible member or spline 60, between first and second electrodes 64 located on opposite surfaces of a flexible member or spline 60, or between a first electrode 64 located on a first spline 60 and a second electrode 64 located on a second spline 60. In the example in which the bipolar electrode pair is formed between electrodes 64 located on different splines 60, the individual electrodes 64 forming the bipolar electrode pair may be both located on the inner surface of their respective splines 60, the outer surface of their respective splines 60 or, alternatively, one electrode 64 may be located on an outer surface of its respective spline 60 and the other electrode 64 forming the bipolar electrode pair may be located on the inner surface of its respective spline 60. These are just some examples.

**[0076]** In some cases, each of the flexible splines 60

may include at least one bipolar electrode pair. In some cases, all of the electrodes 64 located on the flexible splines 60 may be paired together to form a plurality of electrode pairs distributed along the length of the individual flexible splines 60. In some cases, the electrode pairs may be located equidistant from one another along the length of each of the flexible splines 60. Alternatively, the electrode pairs may have a varied spacing forming an electrode array having an asymmetrical distribution. Up to thirty-two bipolar electrode pairs may be distributed throughout the electrode assembly 30 for a total of up to sixty-four electrodes 64 depending upon the overall size and geometry of the electrode assembly 30. However, it is contemplated that the electrode assembly 30 may be configured such that it is capable of carrying fewer or greater than thirty-two bipolar electrode pairs, depending upon the overall size and geometry of the electrode assembly 30 and the desired application.

**[0077]** Figures 5A and 5B are close-up schematic views of two illustrative individual flexible members or splines 60 including a plurality of bipolar electrode pairs 72 distributed along their length. The orientation of the dipole of the bipolar electrode pair 72 does not affect the ability of the bipolar electrode pair 72 in sensing local electrical activity of the heart. However, it may be useful for the clinical or other individual performing the procedure to know whether the positive or negative electrode of the bipolar pair is located on the outer surface 66 of the flexible splines. It will be generally understood by those skilled in the art that each bipolar electrode pair 72 formed across the flexible splines will have the same electrical orientation. In addition or alternatively, at least some bipolar electrode pairs may be formed between adjacent electrodes on the outer or inner surface 66, 68 of the splines 60 (not shown). It will be generally understood that each of the flexible splines 60 forming the electrode assembly 30 will have a similar if not, the same construction, and in some cases, may be substantially planar or flat.

**[0078]** As shown in Figures 5A and 5B, the bipolar electrode pairs 72 may be spaced an equal distance from one another along the length of the spline 60. In some cases, all of the bipolar electrode pairs 72 located along the length of each of the flexible splines 60 of the electrode assembly 30 include a first electrode 74a located on the outer surface 66 and a second electrode 74b located opposite the first electrode 74a on the inner surface 68 of the flexible splines 60. In some cases, as shown in Figure 5A, the electrodes 74a, 74b forming the bipolar electrode pair 72 may be located directly opposite one another across the spline 60. In addition or alternatively, as shown in Figure 5B, the electrodes 74a, 74b forming the bipolar electrode pair 72 may be offset from one another such that the electrodes 74a, 74b forming the bipolar electrode pairs 72 along the length of the flexible member or spline 60 have a staggered configuration. In some cases, a first electrode 74a located on an outer surface 66 of a spline 60 may be offset from a second

electrode 74b located on the inner surface 68 of the spline 60 by one half the measurable distance between adjacent electrodes 74b located on the inner surface of the spline 60. The reverse may also be true. A first electrode 74b located on the inner surface 68 of the spline 60 may be offset from a second electrode 74a located on the outer surface 66 of the spline 60 by one half the measurable distance between adjacent electrodes 74a located on the outer surface 66 of the spline 60. In other cases, a first electrode 74a, 74b of a bipolar electrode pair 72 may be offset from a second electrode 74a, 74b located on the opposite surface 66 or 68 of the spline 60 by one quarter, one third, two thirds or three quarters of the distance between two adjacent electrodes 74 or 74b located on the opposite surface 66 or 68 of the spline 60. These are just some examples.

**[0079]** Referring back to the example shown in Figure 5A, a number of advantages may be associated with utilizing multiple bipolar electrode pairs 72 located on each of the splines 60 of the electrode assembly 30 having a first electrode 74a located on the outer surface 66 and a second electrode 74b located opposite the first electrode 74a on the inner surface 68 of each of the flexible splines 60. Because the electrodes 74a, 74b forming a bipolar electrode pair 72 are located on opposite surfaces 66, 68 of the flexible spline 60, they may be spaced closely together, separated only by the thickness of the spline 60. In some cases, the distance between the two electrodes located on the outer and inner surfaces 66, 68 of the splines 60 may be less than about 1.5 mm, less than about 1.0 mm, less than about 0.8 mm, less than about 0.5 mm and more particularly, less than about 0.4 mm. Such minimal spacing between the electrodes 74a, 74b of a bipolar electrode pair 72 may be not be possible if the electrodes 74a, 74b are located on the same surface (outer or inner) of a spline 60.

**[0080]** Placing the electrodes 74a, 74b on opposite surfaces 66, 68 may avoid problems such as increased impedance and susceptibility to noise associated with reducing the size of the electrodes to minimize the distance between adjacent electrodes. For example, if the individual electrodes forming the bipolar pair are located on the same surface (outer or inner surface) of the spline 60, the spacing between the electrodes may be decreased by decreasing the size of the electrodes such that they may be spaced more closely together. However, the reduction in electrode surface area becomes problematic because the reduced electrode surface area results in an increase in impedance. Placing the electrodes on opposite surfaces of the splines may mitigate impedance concerns by allowing a suitable electrode surface area to be maintained while decreasing the spacing between electrodes.

**[0081]** Additionally, the reduced spacing between the electrodes of the bipolar electrode pair 72 resulting from their location on opposite surfaces of a spline 60 may improve the ability of the bipolar electrode pair 72 to reject far field noise, and may facilitate an improved reduction

in noise even from nearby, adjacent tissue. The ability to reject far field signals, even those generated by adjacent tissue, may improve the output signal generated by the bipolar pair of electrodes by reducing and localizing the sensing area to the tissue directly adjacent the bipolar electrode pair and more particularly, to the tissue adjacent the electrode located on the outer surface 66 of the spline 60. For example, when the electrodes 74a, 74b of a bipolar electrode pair 72 are located on opposite surfaces of a spline 60, they may sense nearly the identical far field signal such that when an activation signal sensed by the first electrode is subtracted from an activation signal generated by the second electrode of the bipolar electrode pair, any noise or other signal pollution resulting from the far field signal is removed from the resulting bipolar electrogram. In addition, any differences between the two activation signals sensed by the first and second electrodes 74a, 74b of the bipolar electrode pair may be emphasized such as when the electrode located on the outer surface 66 of the spline 60 is in contact with heart tissue. The remaining signal after subtraction may be indicative of the local electrical activation directly adjacent the electrode in contact with the heart tissue. Because the signal may be more localized, this may increase the spatial responsivity of the electrode system which includes multiple bipolar electrode pairs including a first electrode located on an outer surface opposite a second electrode located on an inner surface of spline which are used to sense multiple activation signals in a similar manner to produce a map of the electrical activity of the patient's heart. The improved output signal indicative of the sensed electrical activity generated by the bipolar electrode pair may, in turn, produce an improved bipolar electrogram, and may provide a better representation of the electrodes' location in a three-dimensional space for mapping the electrical activity of the patient's heart.

**[0082]** In addition, because each of the bipolar electrode pairs may be orientated substantially perpendicular to the direction of wavefront propagation which may reduce the sensitivity of the bipolar signal to the direction of wavefront propagation. Additionally, the perpendicular orientation to the direction of wavefront propagation may cause the electrode located on the outer surface of the spline to behave in a unipolar fashion with the electrode located on the inner surface serving substantially as a reference electrode. This phenomenon may be true for each bipolar electrode pair 72 located along the length of the spline 60. Finally, because each of the electrodes of the bipolar electrode pairs 72 are substantially co-located in space, this may result in an improved spatial response pattern to the intrinsic electrical activity of the patient's heart resulting in a more accurate representation (map) of the electrical activity of the patient's heart.

**[0083]** In use, according to some embodiments, bipolar electrograms measured using electrodes 74a, 74b on opposing surfaces 66, 68 of each of the splines 60 can also be used for detecting contact with viable tissue. When the tissue nearest the electrode 74a located on

the outer surface 66 is not electrically active or is located far away from the electrode 74a, the signals from the two opposing electrodes 74a, 74b may be substantially identical, and the bipolar electrogram generated by the bipolar electrode pair 72 will have a small amplitude. When tissue is nearest the electrode 74a located on the outer surface 66 and is electrically active, the rapid spatial decay of the local activation will result in a bipolar signal having a large amplitude.

**[0084]** In some embodiments, impedance measurements can also be used to detect and/or confirm tissue contact. The impedance measured separately through opposing electrodes of a bipolar electrode pair 72 may be different because of the medium through which the signal must travel to reach each sensing electrode of the bipolar electrode pair 72. For example, electrode 74a, located on the outer surface 66, may exhibit a greater impedance than electrode 74b, located on the inner surface 68, which may be in contact with mostly blood. A bipolar impedance measurement between the two electrodes may therefore rise sharply with tissue contact, providing a clear and localized indication of tissue contact.

**[0085]** In still other embodiments, to detect tissue proximity rather than just contact, opposing electrodes can be used for a four wire (or more) impedance measurement, with a first pair of electrodes driving current and a second pair of electrodes measuring voltage. For example, current can be driven between at least a first adjacent pair of interior electrodes, and a voltage drop can be measured across a second adjacent pair of exterior electrodes. Tissue proximity will increase the measured voltage due to the lower conductivity of tissue relative to blood. In another example, a current can be driven between a first pair of opposing electrodes and a voltage can be measured using one or more nearby opposing pair of electrodes. The impedance measurements may be repeated for different combinations of electrode pairs. These are just some examples.

**[0086]** The impedance measurements obtained according to the different methods as described herein may be used to determine a distance between the electrode assembly 30 and the heart tissue. Additionally or alternatively, the impedance measurements may be used to weight the different activation times obtained from the bipolar electrograms, and may be used to indicate which activation times correspond to good tissue contact. The impedance measurements also may be used to characterize the tissue being contacted by the different electrodes such as, for example, to confirm whether or not a tissue area of interest has been successfully ablated using the ablation catheter 18.

**[0087]** Figures 6-9D relate to a method of forming an electrode assembly 30 as described herein. In many cases, the expandable electrode assembly 30, including the flexible splines 60 having multiple electrodes located on the outer and inner surfaces 66, 68 may be constructed from a multi-layered flexible sheet 80 including a first flexible printed circuit 82 adhesively bonded to an upper sur-

face of a substrate and a second flexible printed circuit 84 bonded to a lower surface of the same substrate. The first and second flexible printed circuits 82, 84 define the outer and inner surfaces 66, 68 of each of the splines 60.

5 Figure 6 is a cross-sectional view of an exemplary multi-layered flexible sheet 80 including the first and second flexible printed circuits 82, 84 from which an expandable electrode assembly 30, as described herein, may be constructed. The total thickness L of the flexible sheet 80, including the two flexible printed circuits 82, 84, is less than about 0.4 mm and defines the thickness of each of the individual splines 60. It will be generally understood that the flexible sheet 80, including the two flexible printed circuits 82, 84, may be fabricated using a variety of suitable known techniques for producing circuits, including flexible printed circuits, having multiple layers. These techniques may include but are not limited to: laminating, masking, photolithography, etching, plating, sputtering, vapor deposition, and/or the like. Similar techniques or combination of techniques may be used to fabricate a single, dual sided flexible printed circuit as is also described herein.

**[0088]** In some cases, the multi-layered flexible sheet 80 may include a relatively stiff substrate 86. The substrate 86 may be constructed from Nitinol or some other stiff material such as a polyimide or polyether ether ketone (PEEK) that may facilitate shape retention of the electrode assembly 30. Alternative materials such as, for example, a compliant material may be used to form the substrate 86 to obtain the desired mechanical characteristics. A first flexible printed circuit 82 defining at least a first electrode may be formed on the upper surface of the substrate 86 and a second flexible printed circuit 84 defining at least a second electrode may be formed on the lower surface of the substrate. In forming each of the first and second flexible printed circuits 82, 84, first metallization layer 88a, 88b may be bonded to the upper and lower surfaces of the substrate 86 using an adhesive layer 92a, 92b. An insulating layer 96a, 96b may be deposited over the first metallization layer 88a, 88b. A second metallization layer 102a, 102b may be formed over the insulating layer 96a, 96b. A connection can be formed by constructing a via between the two metallization layers 88a and 102a and 88b, 102b. A via can be formed by creating a hole through both metallization layers 88, 102 and the insulating layer 96 and then plating the walls of the hole between the two metallization layers 88, 102, to form a metal connection 108a, 108b. A topcoat layer 110a, 110b may then be provided over the outer metallization layers 102a, 102b. The topcoat layer 110a, 110b serves to insulate portions of the outer metallization layer 102a, 102b from external contact. Portions of the topcoat layer 110a, 110b may be removed at selected locations along the flexible printed circuits 82, 84 and an additional metal layer 112a, 112b may be sputter-coated or plated onto the exposed portion of the outer metallization layers 102a, 102b to form the electrodes 64.

**[0089]** The material used to form the electrodes 64 may

be selected to reduce impedance of the electrochemical interface between the electrode 64 and blood. Reducing impedance may reduce overall system noise. Exemplary electrode materials include, but are not limited to gold, stainless steel, platinum, platinum-iridium, titanium nitride, platinum black or iridium oxide. In some cases, the electrodes 64 may be fabricated from a gold metal layer coated with iridium oxide.

**[0090]** In some cases, each flexible spline 60 used to form an expandable electrode assembly 30, such as described herein, may be formed from an individual flexible sheet having a first flexible printed circuit formed on an upper surface of substrate and a second flexible printed circuit formed on a lower surface of a substrate. The individual flexible splines 60 may be mechanically joined together to form an expandable electrode assembly 30, as described herein.

**[0091]** Alternatively, the flexible splines 60 may be formed from a single, dual-sided flexible printed circuit having an upper surface including a first electrode of at least one bipolar electrode pair formed therein and a lower surface including a second electrode of the bipolar electrode pair formed therein. It will be generally understood that the single, dual-sided flexible printed circuit may include multiple electrodes formed in the upper and lower surfaces thereof. The electrodes located on opposite surfaces of the splines may define multiple bipolar electrode pairs having a first electrode located on the upper surface of the spline and a second electrode located opposite the first electrode on the lower surface. In some cases, the single, dual-sided flexible printed circuit may include a stiffened core layer. The stiffened core layer may incorporate a shape memory material (e.g. Nitinol) or some other stiff material such as a polyimide or polyether ether ketone (PEEK) that may facilitate shape retention of the electrode assembly 30. Alternative materials such as, for example, a compliant material may be used to form the core layer to obtain the desired mechanical characteristics.

**[0092]** In other cases, the flexible members or splines can also be manufactured from a single, multilayered flexible printed circuit laminated to a mechanical stiffener. Figures 7A and 7B show schematic views of the inner and outer surfaces 166, 168 of a portion of a flexible spline 160 incorporating a single flexible printed circuit and a mechanical stiffener 172. The flexible printed circuit may have electrodes 164 formed on both sides of a substrate (e.g. polyimide or PEEK), and may contain multiple conductive layers (e.g. copper or gold or another suitable conductive metal or metal alloy) to route the signal lines from each electrode 160 along the spline 160. A mechanical stiffener 172, fabricated from a suitable metal or plastic material, may be laminated to one side of the flexible printed circuit. The stiffener 172 may feature openings 176 that correspond with the inside electrodes of the flexible circuit, allowing the electrodes 164 to be exposed to the blood pool in vivo and acquire electrical signals.

**[0093]** Figure 8A shows a top plan view and Figure 8B

is a bottom plan view of a multi-layered flexible sheet used to construct an electrode assembly. Figures 9A-9D provide a stepwise illustration of an exemplary method of constructing the expandable electrode assembly from a flexible sheet 80 including two flexible printed circuits 82, 84, as described herein. Starting with a planar, flexible sheet 80, as shown in Figure 9A, a series of apertures 124 may be formed in a distal region of the flexible sheet 80 using laser cutting, die cutting, chemical etching, or another precision cutting means. Together the plurality of apertures 124 forms a bonding region 116. A termination section 120 may be formed at the opposite end of the flexible sheet 80. The termination section 120 may be used to bond the electrode assembly 30 to the catheter body. Next, as shown in Figure 9B, the planar flexible sheet 80 may be wound around a major axis 130, bringing first edge 132 toward a second edge 134 of the flexible sheet 80. Figure 9C shows the two edges 132, 134 juxtaposed with both edges 132, 134 fixed to define a generally cylindrical structure. In some cases, the edges of the distal bonding region 116 may be secured by encapsulating the distal bonding region 116 with an adhesive, and the edges of termination section 120 may be secured by anchoring or bonding it to a distal portion of the catheter body. In some cases, as shown in Figures 9A-9D, the termination band may include first and second tabs 136, 138 which may be inserted into a lumen or slot provided in the catheter body and then secured within and adhesive or other suitable bonding technique, and which may include electrical connections to route the electrode signals to the processing system 20 (Figure 1). Figure 9D shows the completed electrode assembly 30.

**[0094]** In some cases, the flexible splines 60 may be fully separated from one another such that they are not connected. The distal ends of each of the flexible splines may be mechanically joined together using a band, ring or cap provided for that purpose. In one example, each of the distal ends of the separated splines may be inserted into a corresponding slot provided in a distal cap. The distal ends of the separated splines may be mechanically interlocked with the cap by a locking feature formed at the distal end of the spline. The cap may form an atraumatic tip of the electrode assembly. The proximal ends of the separated splines may be anchored or bonded to a distal end of a catheter body. In some cases, the proximal ends of the separated splines may be first joined together using a band or ring before anchoring or bonding the splines to the distal end of catheter body using an adhesive or potting material.

**[0095]** Those skilled in the art will recognize that the present disclosure may be manifested in a variety of forms other than the specific embodiments described and contemplated herein. Accordingly, departure in form and detail may be made without departing from the scope of the present disclosure as described in the appended claims.

## Claims

1. A catheter (10) comprising:
  - an elongate catheter body (34) extending from a proximal end (38) to a distal end (42); and
  - an expandable electrode assembly (30) disposed at the distal end (42) of the catheter body (34), the electrode assembly (30) configured to transition from a collapsed configuration to an expanded configuration and comprising at least one flexible member having an outer surface (66) and an inner surface (68), wherein the at least one flexible member (60) comprises a first electrode (74a) disposed on the outer surface (66) of the flexible member (60) and a second electrode (74b) disposed on the inner surface (68) of the flexible member (60),
  - characterized in that** the first and second electrodes (74a, 74b) are configured to connect to separate poles of a generator to form a bipolar electrode pair and wherein a distance between the first and second electrodes (74a, 74b) is less than 0.5mm.
2. The catheter (10) of claim 1, wherein the first electrode (74a) is located directly opposite the second electrode (74b).
3. The catheter (10) of any one of claims 1 or 2, wherein the first electrode (74a) is offset from the second electrode (74b).
4. The catheter (10) of any one of claims 1-3, wherein the flexible member (60) comprises at least one flexible printed circuit.
5. The catheter (10) of any one of claims 1-4, wherein the flexible member (60) comprises a single, dual sided flexible printed circuit wherein the first electrode (74a) is formed on an outer surface of the flexible printed circuit and the second electrode (74b) is formed on an inner surface of the flexible printed circuit.
6. The catheter (10) of any one of claims 1-5, wherein the flexible member (60) comprises a first flexible printed circuit (82) defining the first electrode (74a) formed on an upper surface of a substrate (86) and a second flexible printed circuit (84) defining the second electrode (74b) formed on a lower surface of the substrate (86).
7. The catheter (10) of any one of claims 1-6, wherein the flexible member (60) comprises multiple bipolar electrode pairs defined by a first electrode (74a) disposed on the outer surface (66) of a flexible member (60) and a second electrode (74b) disposed on the inner surface (68) each of the flexible member (60).
8. The catheter (10) of any one of claims 1-7, further comprising two or more flexible members (60), each of the two or more flexible members (60) comprising at least a first electrode (74a) disposed on the outer surface (66) of the flexible member (60) and at least a second electrode (74b) disposed on the inner surface (68) of the flexible member (60).
9. The catheter (10) of claim 8, wherein the first and second electrodes (74a, 74b) are configured to form a bipolar electrode pair across the outer and inner surface (68) of the flexible member (60).
10. A method of fanning a flexible electrode assembly (30), the method comprising:
  - forming a flexible electrode assembly (30) comprising at least one flexible member (60) having an outer surface (66) and an inner surface (68), wherein the at least one flexible member (60) comprises a first electrode (74a) disposed on the outer surface (66) of the flexible member (60) and a second electrode (74b) disposed on the inner surface (68) of the flexible member (60) and wherein the flexible electrode assembly (30) is configured to transition from a collapsed configuration to an expanded configuration, coupling the flexible electrode assembly to a distal end of an elongate catheter body, **characterized in that** the first electrode (74a) and the second electrode (74b) are configured to form a bipolar electrode pair and wherein a distance between the first electrode (74a) and the second electrode (74b) is less than 0.5mm;
11. The method of claim 10, further comprising:
  - forming a flexible layered sheet (80) comprising at least one flexible printed circuit defining a first electrode (74a) on an outer surface of the flexible layered sheet (80) and a second electrode (74b) on an inner surface of the flexible layered sheet (80);
  - separating the flexible layered sheet (80) into two or more flexible members (60), each flexible member having a first electrode (74a) located on an outer surface and a second electrode (74b) located on an inner surface; and
  - forming an expandable electrode assembly (30) from at least one of the flexible members (60).
12. The method of any one of claims 10-11, further comprising forming an expandable electrode assembly (30) from two or more flexible members (60) by joining the two or more flexible members (60) together at a first end of each of the two or more flexible mem-

bers (60).

13. The method of any one of claims 10-12, further comprising joining the two or more flexible members (60) together at a second end of each of the two or more flexible members (60).

### Patentansprüche

1. Katheter (10), welcher aufweist:

einen länglichen Katheterkörper (34), der sich von einem proximalen Ende (38) zu einem distalen Ende (42) erstreckt; und  
 eine erweiterbare Elektrodenanordnung (30), die an dem distalen Ende (42) des Katheterkörpers (34) angeordnet ist, wobei die Elektrodenanordnung (30) konfiguriert ist, aus einer zusammengeklappten Konfiguration in eine erweiterte Konfiguration überzugehen, und zumindest ein flexibles Teil mit einer äußeren Oberfläche (66) und einer inneren Oberfläche (68) aufweist, wobei das zumindest eine flexible Teil (60) eine erste Elektrode (74a), die auf der äußeren Oberfläche (66) des flexiblen Teils (60) angeordnet ist, und eine zweite Elektrode (74b), die auf der inneren Oberfläche (68) des flexiblen Teils (60) angeordnet ist, aufweist,  
**dadurch gekennzeichnet, dass**  
 die erste und die zweite Elektrode (74a, 74b) konfiguriert sind, getrennte Pole eines Generators zu verbinden, um ein bipolares Elektrodenpaar zu bilden, wobei ein Abstand zwischen der ersten und der zweiten Elektrode (74a, 74b) kleiner als 0,5 mm ist.

2. Katheter (10) nach Anspruch 1, bei dem die erste Elektrode (74a) direkt gegenüber der zweiten Elektrode (74b) angeordnet ist.
3. Katheter (10) nach einem der Ansprüche 1 oder 2, bei dem die erste Elektrode (74a) gegenüber der zweiten Elektrode (74b) versetzt ist.
4. Katheter (10) nach einem der Ansprüche 1- 3, bei dem das flexible Teil (60) zumindest eine flexible Leiterplatte aufweist.
5. Katheter (10) nach einem der Ansprüche 1- 4, bei dem das flexible Teil (60) eine einzelne, doppelseitige flexible Leiterplatte aufweist, wobei die erste Elektrode (74a) auf einer äußeren Oberfläche der flexiblen Leiterplatte gebildet ist und die zweite Elektrode (74b) auf einer inneren Oberfläche der flexiblen Leiterplatte gebildet ist.
6. Katheter (10) nach einem der Ansprüche 1- 5, bei

dem das flexible Teil (60) eine erste flexible Leiterplatte (82), die auf einer oberen Oberfläche eines Substrats (86) gebildete erste Elektrode (74a) definiert, und eine zweite flexible Leiterplatte (84), die auf einer unteren Oberfläche des Substrats (86) gebildete zweite Elektrode (74b) definiert, aufweist.

7. Katheter (10) nach einem der Ansprüche 1- 6, bei dem das flexible Teil (60) mehrere bipolare Elektrodenpaare aufweist, die durch eine erste Elektrode (74a), die auf der äußeren Oberfläche (66) eines flexiblen Teils (60) angeordnet ist, und eine zweite Elektrode (74b), die auf der inneren Oberfläche (68) jeweils des flexiblen Teils (60) angeordnet ist, definiert sind.
8. Katheter (10) nach einem der Ansprüche 1- 7, weiterhin aufweisend zwei oder mehr flexible Teile (60), wobei jedes der zwei oder mehr flexiblen Teile (60) zumindest eine erste Elektrode (74a), die auf der äußeren Oberfläche (66) des flexiblen Teils (60) angeordnet ist, und zumindest eine zweite Elektrode (74b), die auf der inneren Oberfläche (68) des flexiblen Teils (60) angeordnet ist, aufweist.
9. Katheter (10) nach Anspruch 8, bei dem die erste und die zweite Elektrode (74a, 74b) konfiguriert sind, ein bipolares Elektrodenpaar über die äußere und die innere Oberfläche (68) des flexiblen Teils (60) hinweg zu bilden.
10. Verfahren zum Bilden einer flexiblen Elektrodenanordnung (30), welches Verfahren aufweist:

Bilden einer flexiblen Elektrodenanordnung (30), die zumindest ein flexibles Teil (60) mit einer äußeren Oberfläche (66) und einer inneren Oberfläche (68) aufweist, wobei das zumindest eine flexible Teil (60) eine erste Elektrode (74a), die auf der äußeren Oberfläche (66) des flexiblen Teils (60) angeordnet ist, und eine zweite Elektrode (74b), die auf der inneren Oberfläche (68) des flexiblen Teils (60) angeordnet ist, aufweist, und wobei die flexible Elektrodenanordnung (30) konfiguriert ist, aus einer zusammengeklappten Konfiguration in eine erweiterte Konfiguration überzugehen, und Koppeln der flexiblen Elektrodenanordnung mit einem distalen Ende eines länglichen Katheterkörpers,  
**dadurch gekennzeichnet, dass**  
 die erste Elektrode (74a) und die zweite Elektrode (74b) konfiguriert sind, ein bipolares Elektrodenpaar zu bilden, wobei ein Abstand zwischen der ersten Elektrode (74a) und der zweiten Elektrode (74b) kleiner als 0,5 mm ist.

11. Verfahren nach Anspruch 10, welches weiterhin aufweist:

Bilden einer flexiblen geschichteten Platte (80), die zumindest eine flexible Leiterplatte, die eine erste Elektrode (74a) auf einer äußeren Oberfläche der flexiblen geschichteten Platte (80) und eine zweite Elektrode (74b) auf einer inneren Oberfläche der flexiblen geschichteten Platte (80) definiert, aufweist;

Trennen der flexiblen geschichteten Platte (80) in zwei oder mehr flexible Teile (60), wobei jedes flexible Teil eine erste Elektrode (74a), die auf einer äußeren Oberfläche angeordnet ist, und eine zweite Elektrode (74b), die auf einer inneren Oberfläche angeordnet ist, hat; und  
Bilden einer erweiterbaren Elektrodenanordnung (30) aus zumindest einem der flexiblen Teile (60).

12. Verfahren nach einem der Ansprüche 10-11, weiterhin aufweisend das Bilden einer erweiterbaren Elektrodenanordnung (30) aus zwei oder mehr flexiblen Teilen (60) durch Verbinden der zwei oder mehr flexiblen Teile (60) an einem ersten Ende jedes der zwei oder mehr flexiblen Teile (60) miteinander.
13. Verfahren nach einem der Ansprüche 10-12, weiterhin aufweisend das Verbinden der zwei oder mehr flexiblen Teile (60) an einem zweiten Ende von jedem der zwei oder mehr flexiblen Teile (60) miteinander.

## Revendications

1. Cathéter (10) comprenant :

un corps de cathéter allongé (34) qui s'étend depuis une extrémité proximale (38) jusqu'à une extrémité distale (42) ; et

un ensemble d'électrode(s) pouvant être déployé (30) qui est disposé au niveau de l'extrémité distale (42) du corps de cathéter (34), l'ensemble d'électrode(s) (30) étant configuré de manière à ce qu'il réalise une transition depuis une configuration repliée jusqu'à une configuration déployée et comprenant au moins un élément flexible qui comporte une surface externe (66) et une surface interne (68), dans lequel l'au moins un élément flexible (60) comprend une première électrode (74a) qui est disposée sur la surface externe (66) de l'élément flexible (60) et une seconde électrode (74b) qui est disposée sur la surface interne (68) de l'élément flexible (60) ;

**caractérisé en ce que :**

les première et seconde électrodes (74a, 74b) sont configurées de manière à ce qu'elles soient connectées à des pôles sé-

parés d'un générateur de manière à ce qu'elles forment une paire d'électrodes bipolaires et dans lequel une distance entre les première et seconde électrodes (74a, 74b) est inférieure à 0,5 mm.

2. Cathéter (10) selon la revendication 1, dans lequel la première électrode (74a) est située directement à l'opposé de la seconde électrode (74b).
3. Cathéter (10) selon l'une quelconque des revendications 1 et 2, dans lequel la première électrode (74a) est décalée par rapport à la seconde électrode (74b).
4. Cathéter (10) selon l'une quelconque des revendications 1 à 3, dans lequel l'élément flexible (60) comprend au moins un circuit imprimé flexible.
5. Cathéter (10) selon l'une quelconque des revendications 1 à 4, dans lequel l'élément flexible (60) comprend un unique circuit imprimé flexible double face, dans lequel la première électrode (74a) est formée sur une surface externe du circuit imprimé flexible et la seconde électrode (74b) est formée sur une surface interne du circuit imprimé flexible.
6. Cathéter (10) selon l'une quelconque des revendications 1 à 5, dans lequel l'élément flexible (60) comprend un premier circuit imprimé flexible (82) qui définit la première électrode (74a) qui est formée sur une surface supérieure d'un substrat (86) et un second circuit imprimé flexible (84) qui définit la seconde électrode (74b) qui est formée sur une surface inférieure du substrat (86).
7. Cathéter (10) selon l'une quelconque des revendications 1 à 6, dans lequel l'élément flexible (60) comprend de multiples paires d'électrodes bipolaires qui sont définies par une première électrode (74a) qui est disposée sur la surface externe (66) d'un élément flexible (60) et par une seconde électrode (74b) qui est disposée sur la surface interne (68) de l'élément flexible (60).
8. Cathéter (10) selon l'une quelconque des revendications 1 à 7, comprenant en outre deux éléments flexibles ou plus (60), chacun des deux éléments flexibles ou plus (60) comprenant au moins une première électrode (74a) qui est disposée sur la surface externe (66) de l'élément flexible (60) et au moins une seconde électrode (74b) qui est disposée sur la surface interne (68) de l'élément flexible (60).
9. Cathéter (10) selon la revendication 8, dans lequel les première et seconde électrodes (74a, 74b) sont configurées de manière à ce qu'elles forment une paire d'électrodes bipolaires sur les surfaces externe

et interne (68) de l'élément flexible (60).

10. Procédé de formation d'un ensemble d'électrode(s) flexible (30), le procédé comprenant :

5

la formation d'un ensemble d'électrode(s) flexible (30) qui comprend au moins un élément flexible (60) qui comporte une surface externe (66) et une surface interne (68), dans lequel l'au moins un élément flexible (60) comprend une première électrode (74a) qui est disposée sur la surface externe (66) de l'élément flexible (60) et une seconde électrode (74b) qui est disposée sur la surface interne (68) de l'élément flexible (60) et dans lequel l'ensemble d'électrode(s) flexible (30) est configuré de manière à ce qu'il réalise une transition depuis une configuration repliée jusqu'à une configuration déployée, l'ensemble d'électrode(s) flexible étant couplé à une extrémité distale d'un corps de cathéter allongé, **caractérisé en ce que** la première électrode (74a) et la seconde électrode (74b) sont configurées de manière à ce qu'elles forment une paire d'électrodes bipolaires et dans lequel une distance entre la première électrode (74a) et la seconde électrodes (74b) est inférieure à 0,5 mm.

10

15

20

25

11. Procédé selon la revendication 10, comprenant en outre :

30

la formation d'une feuille en couche flexible (80) qui comprend au moins un circuit imprimé flexible qui définit une première électrode (74a) sur une surface externe de la feuille en couche flexible (80) et une seconde électrode (74b) sur une surface interne de la feuille en couche flexible (80) ;

35

la séparation de la feuille en couche flexible (80) selon deux éléments flexibles ou plus (60), chaque élément flexible comportant une première électrode (74a) qui est située sur une surface externe et une seconde électrode (74b) qui est située sur une surface interne ; et

40

la formation d'un ensemble d'électrode(s) pouvant être déployé (30) à partir d'au moins l'un des éléments flexibles (60).

45

12. Procédé selon l'une quelconque des revendications 10 et 11, comprenant en outre la formation d'un ensemble d'électrode(s) pouvant être déployé (30) à partir de deux éléments flexibles ou plus (60) en joignant les deux éléments flexibles ou plus (60) ensemble au niveau d'une première extrémité de chacun des deux éléments flexibles ou plus (60).

50

55

13. Procédé selon l'une quelconque des revendications 10 à 12, comprenant en outre la jonction des deux

éléments flexibles ou plus (60) ensemble au niveau d'une seconde extrémité de chacun des deux éléments flexibles ou plus (60).

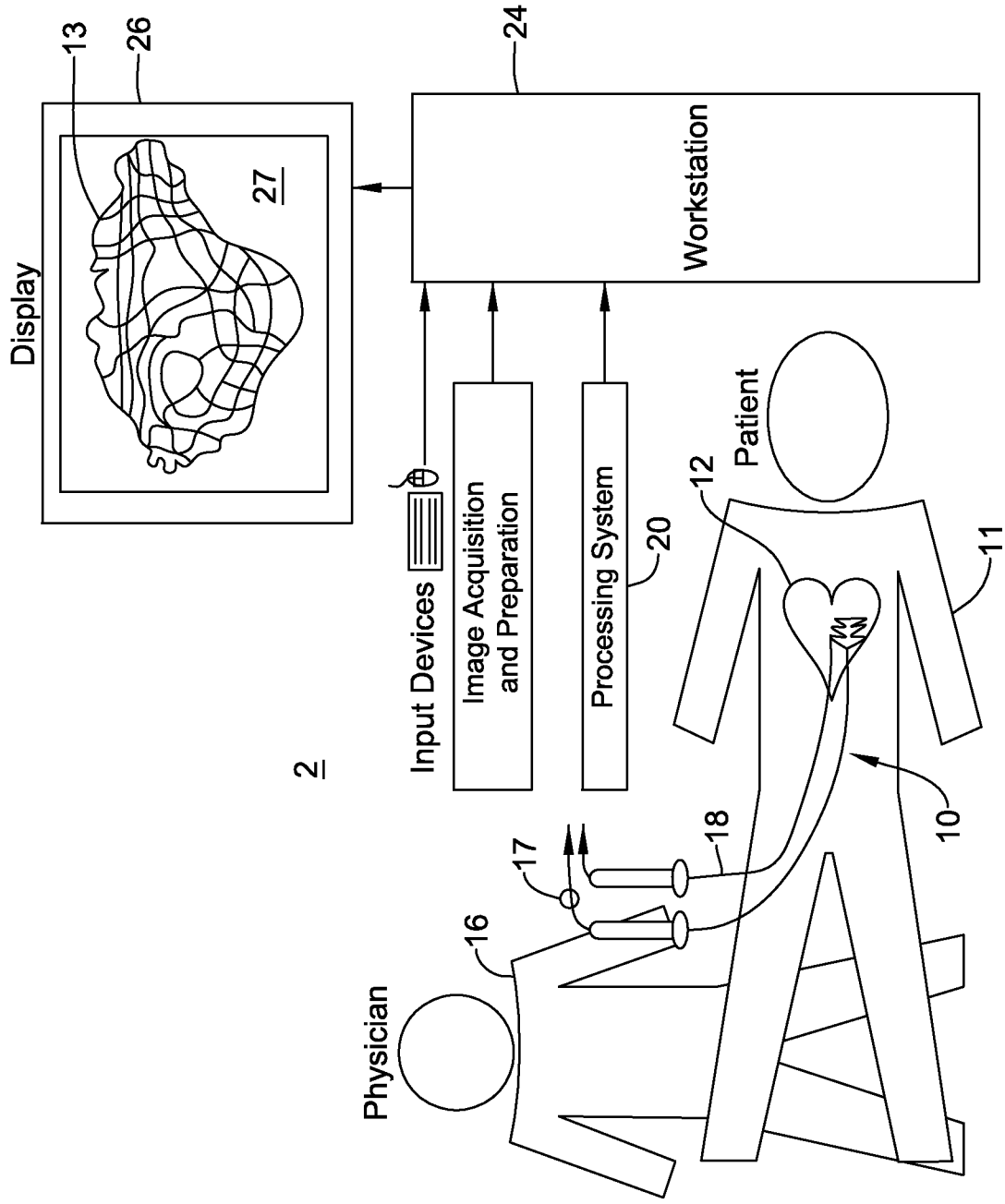

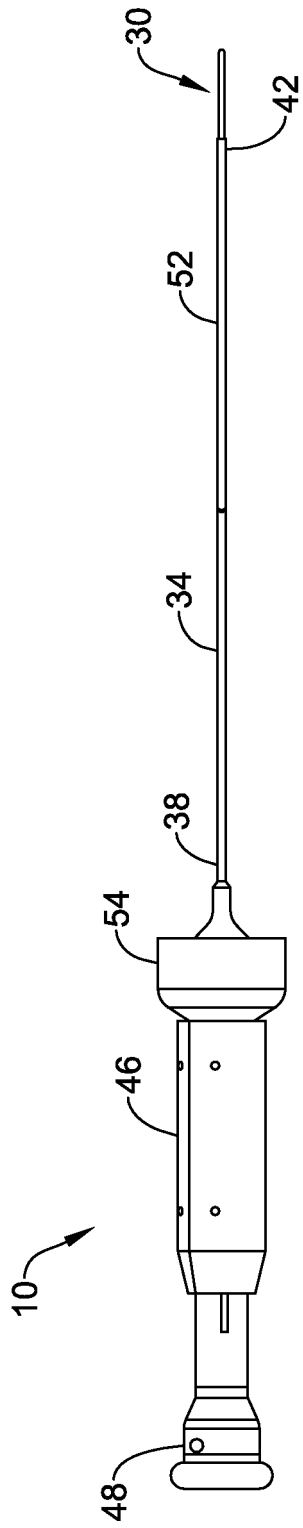

FIG. 2A

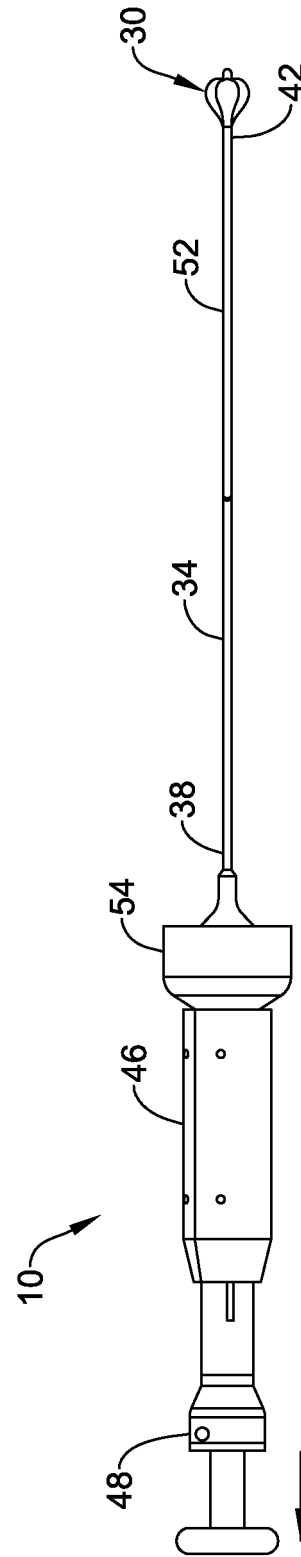
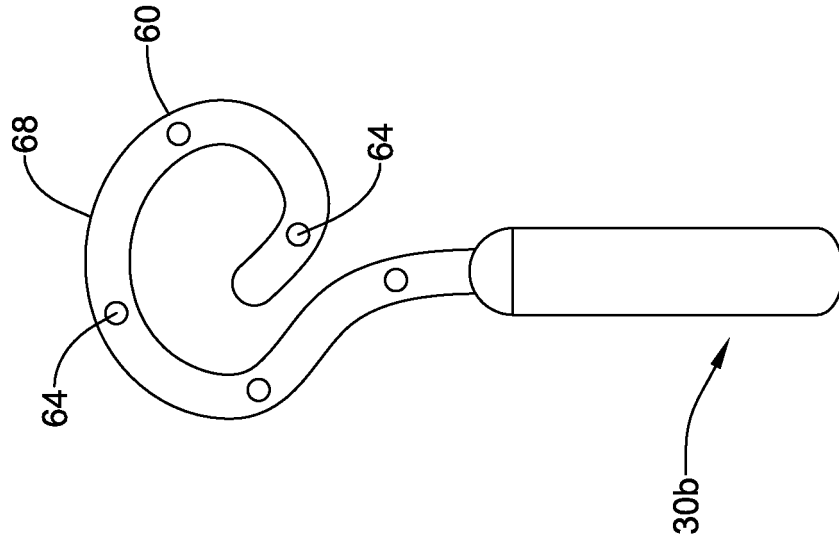
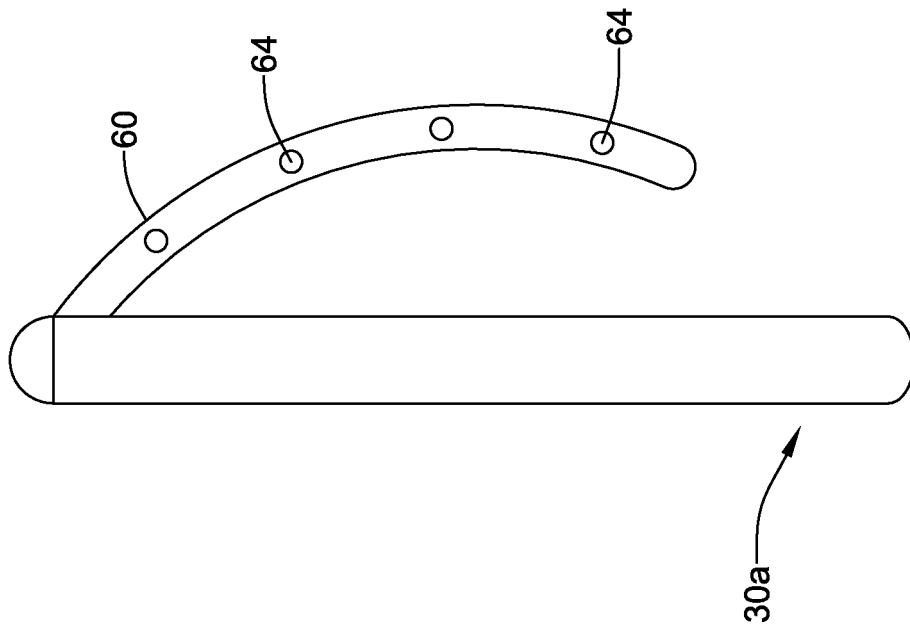

FIG. 2B



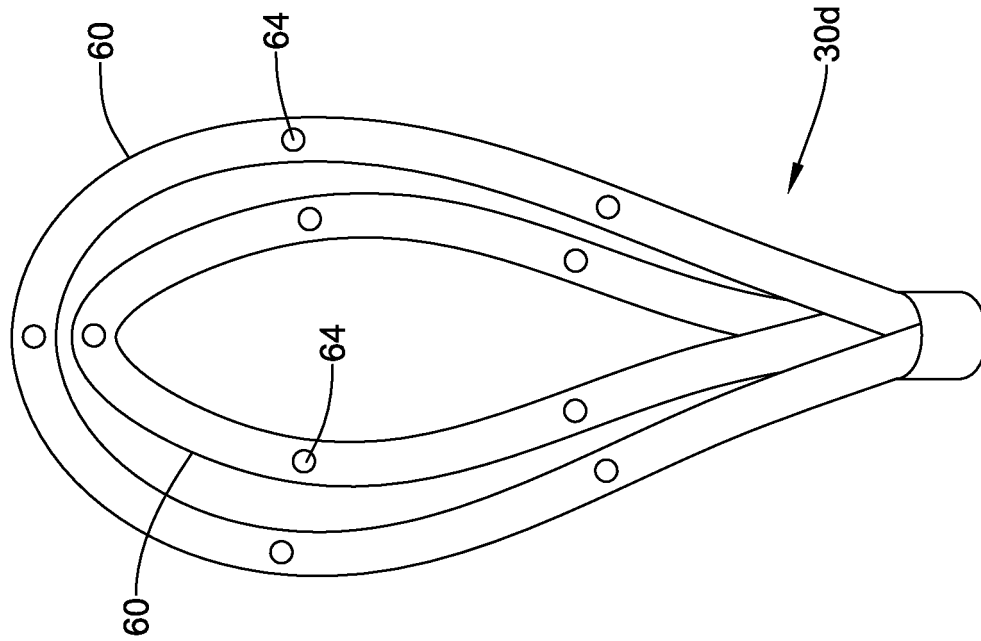

FIG.3D

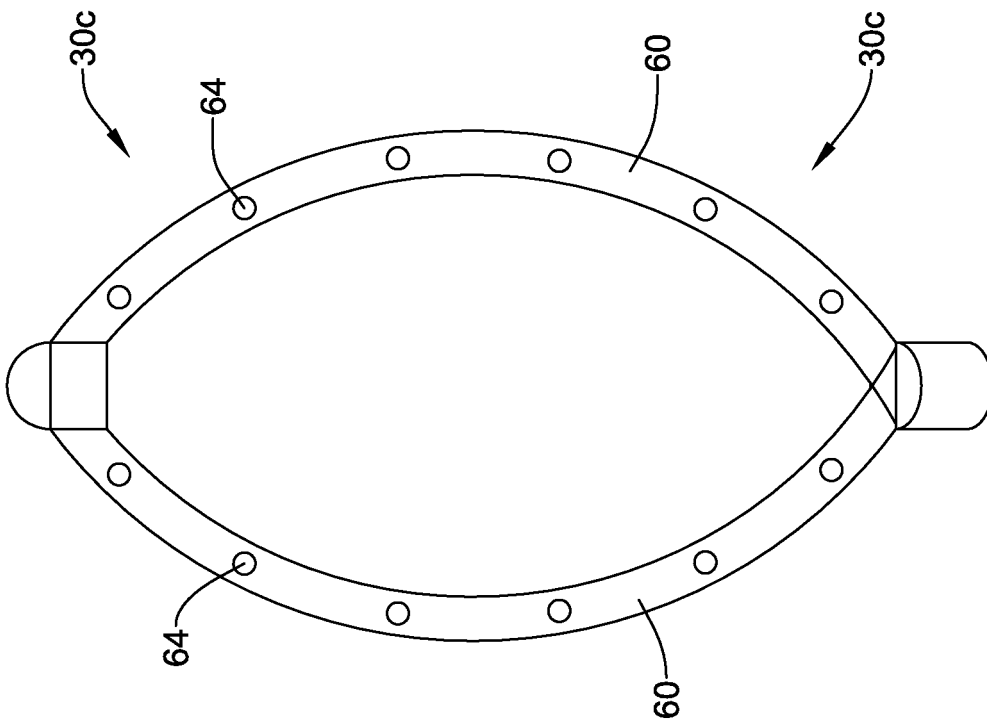

FIG.3C

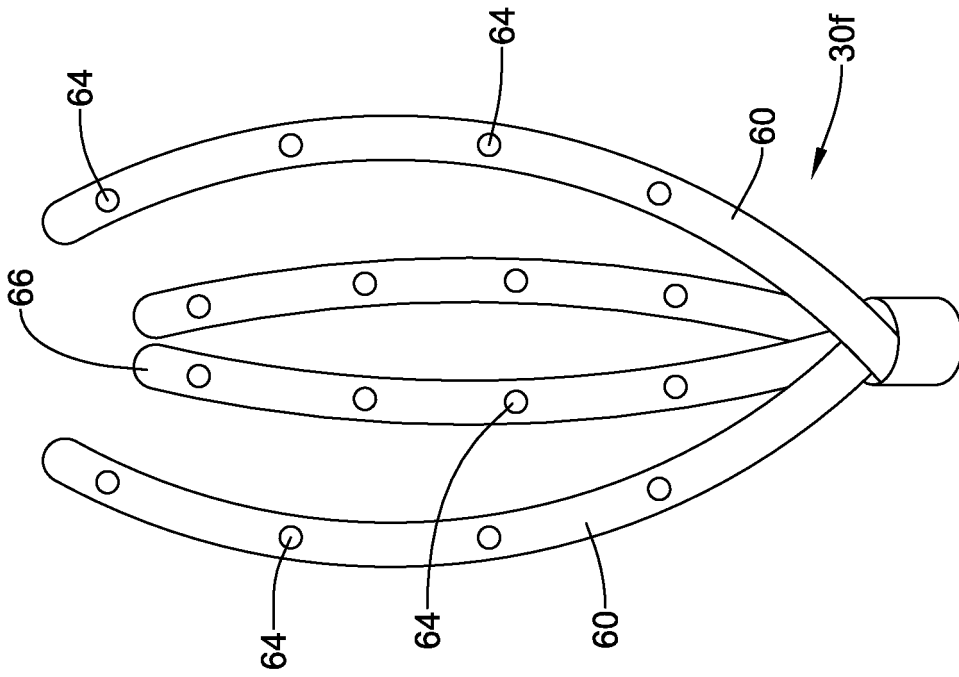

FIG.3F

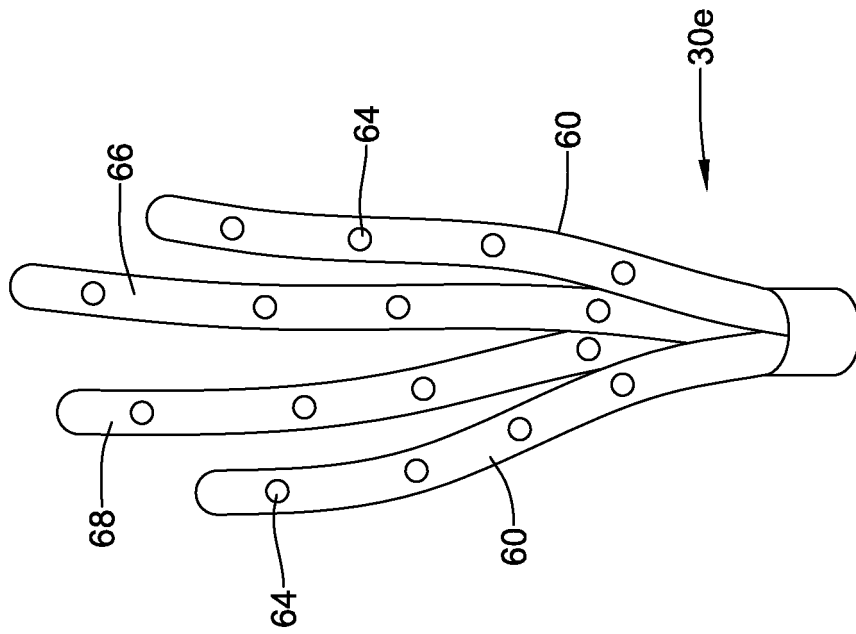

FIG.3E

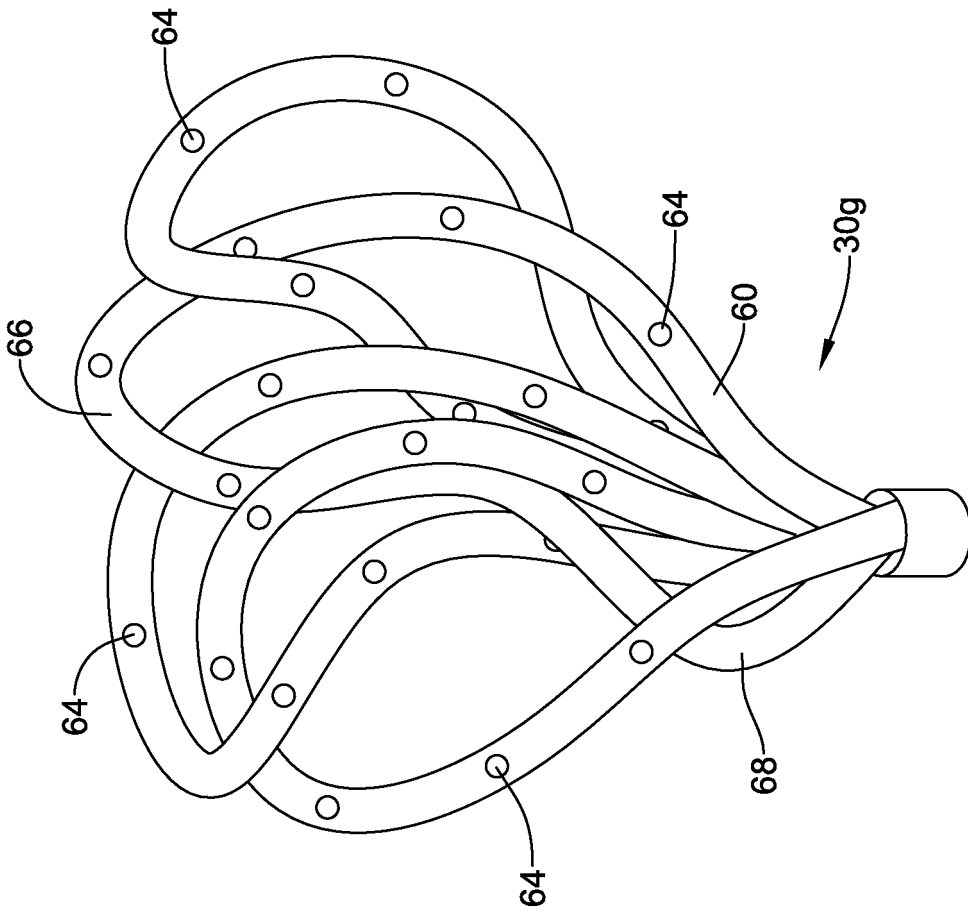

FIG.3G

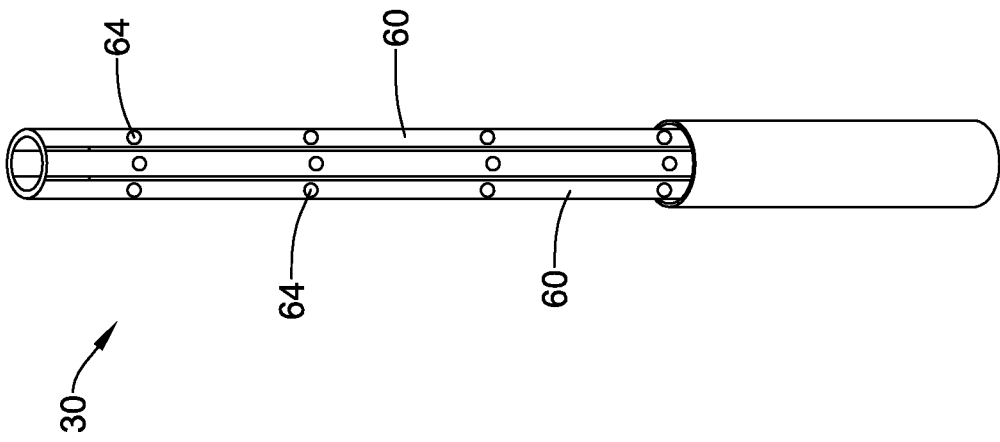

FIG. 4A

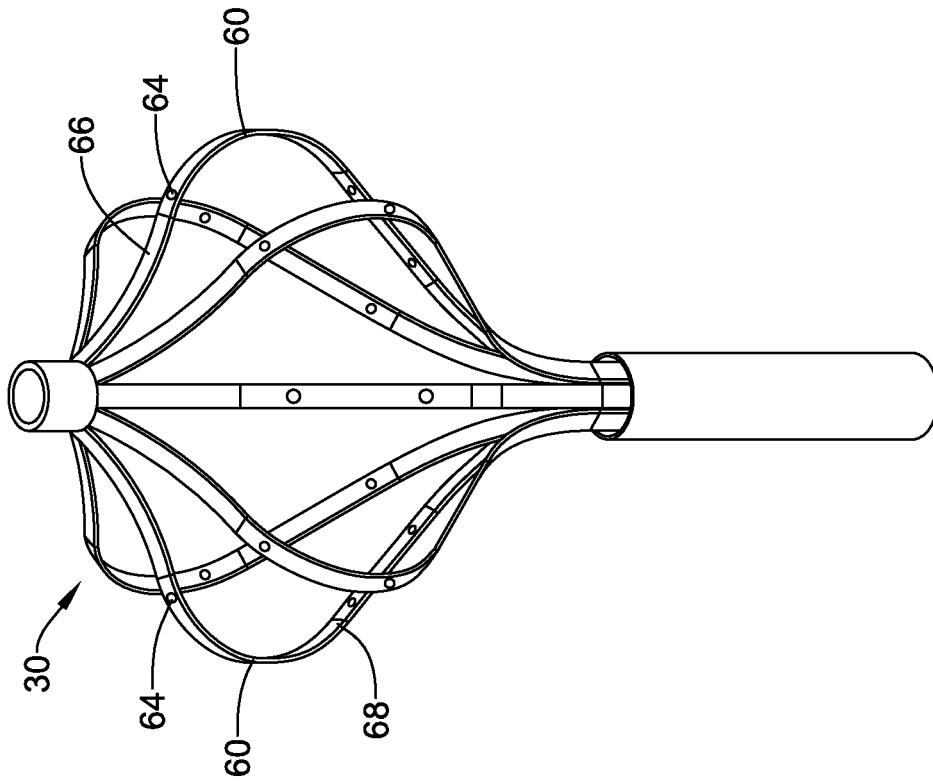

FIG.4B

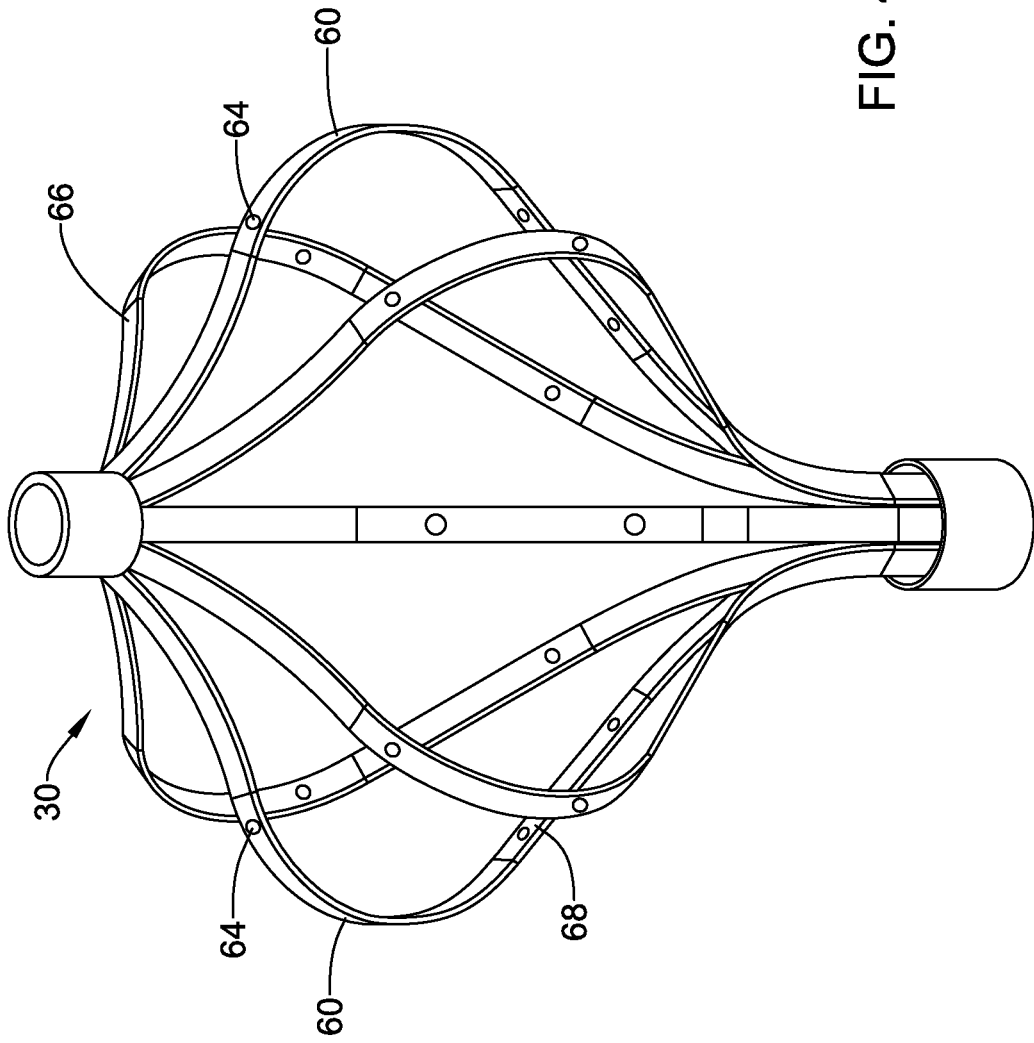

FIG. 4C

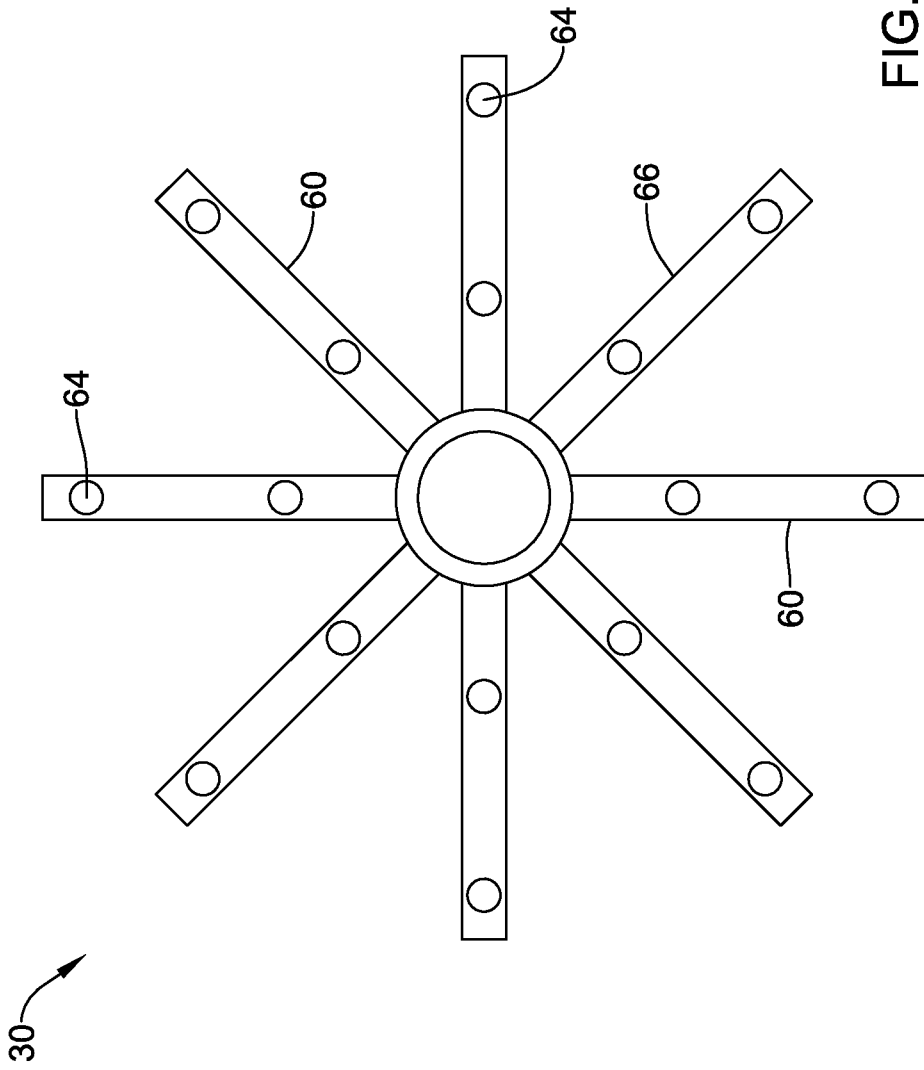

FIG. 4D

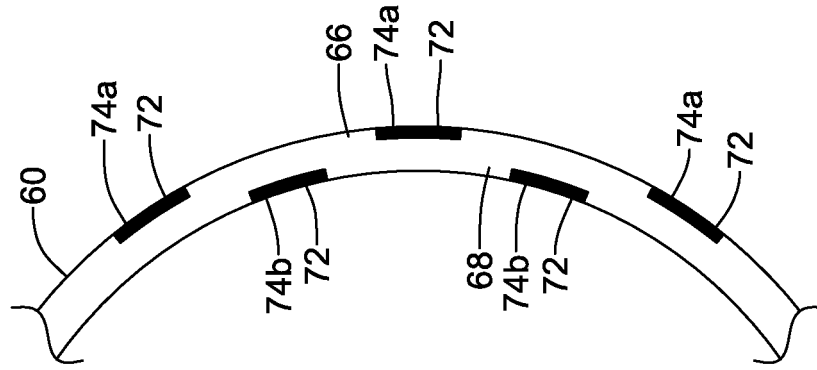

FIG. 5B

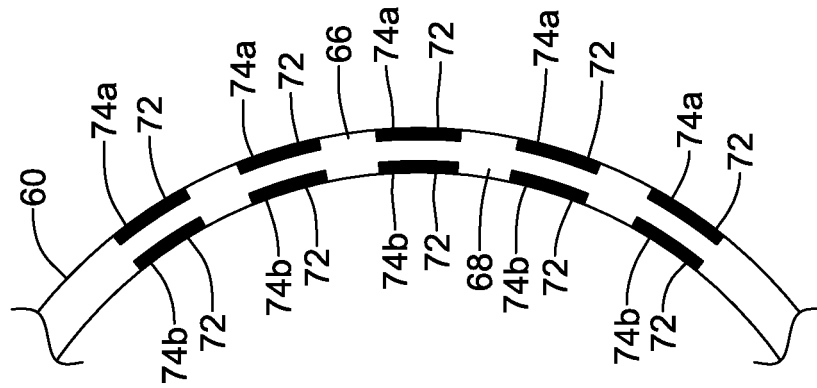

FIG. 5A

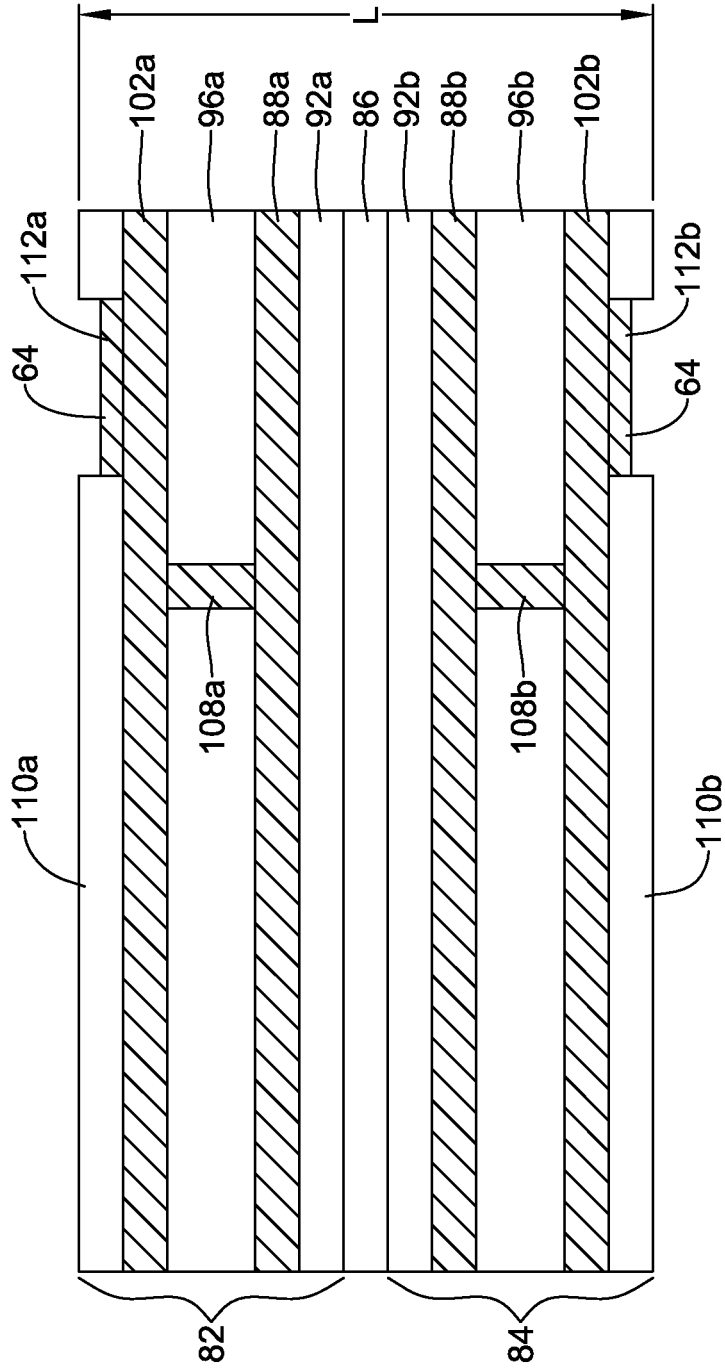

FIG. 6

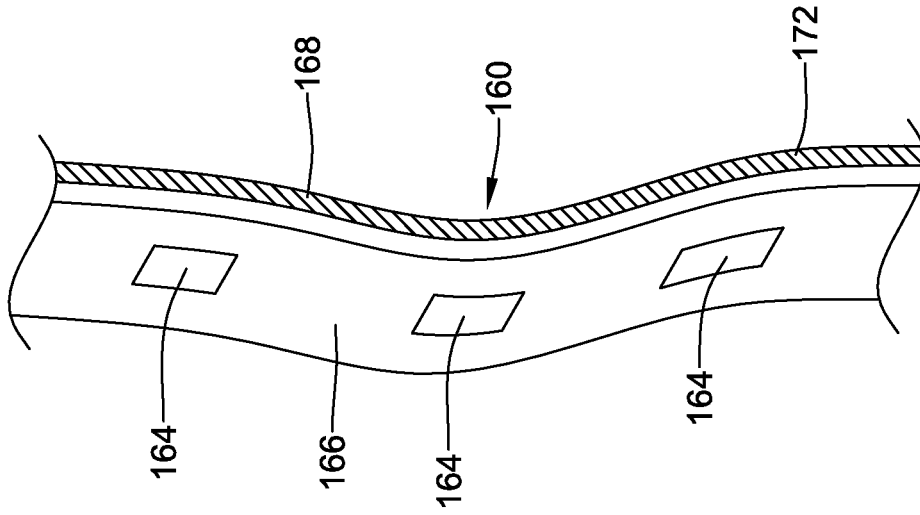

FIG. 7B

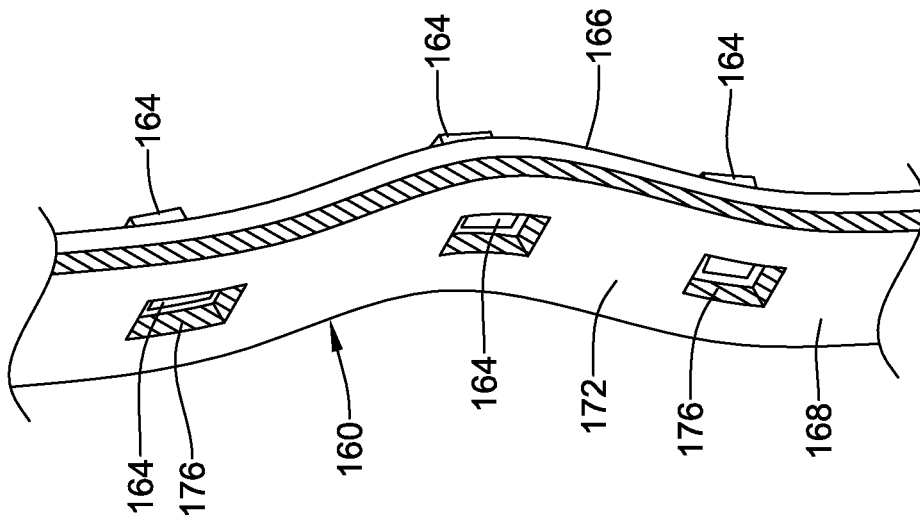

FIG. 7A

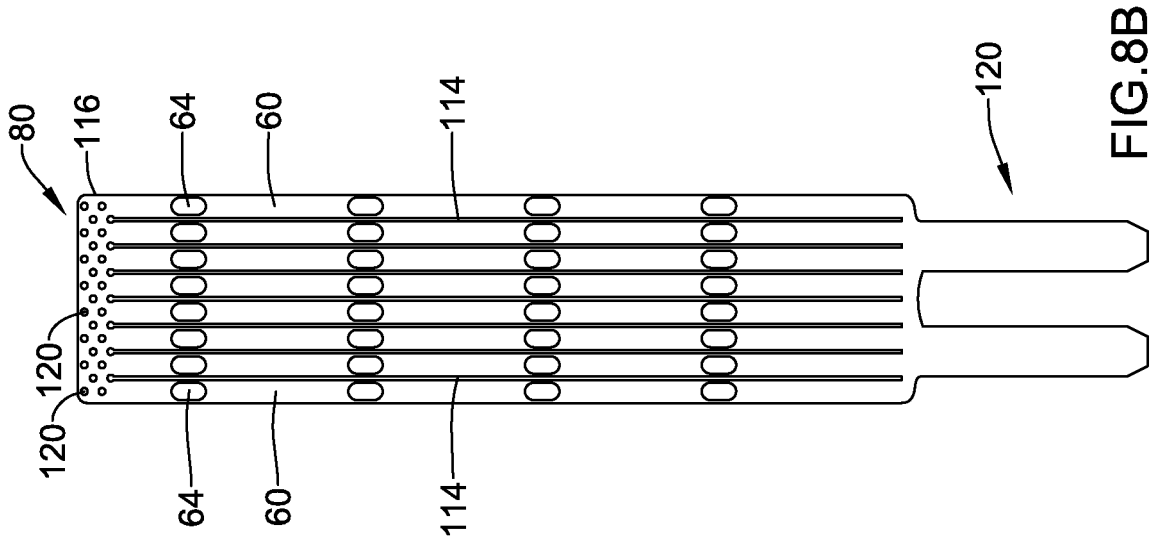

FIG. 8B

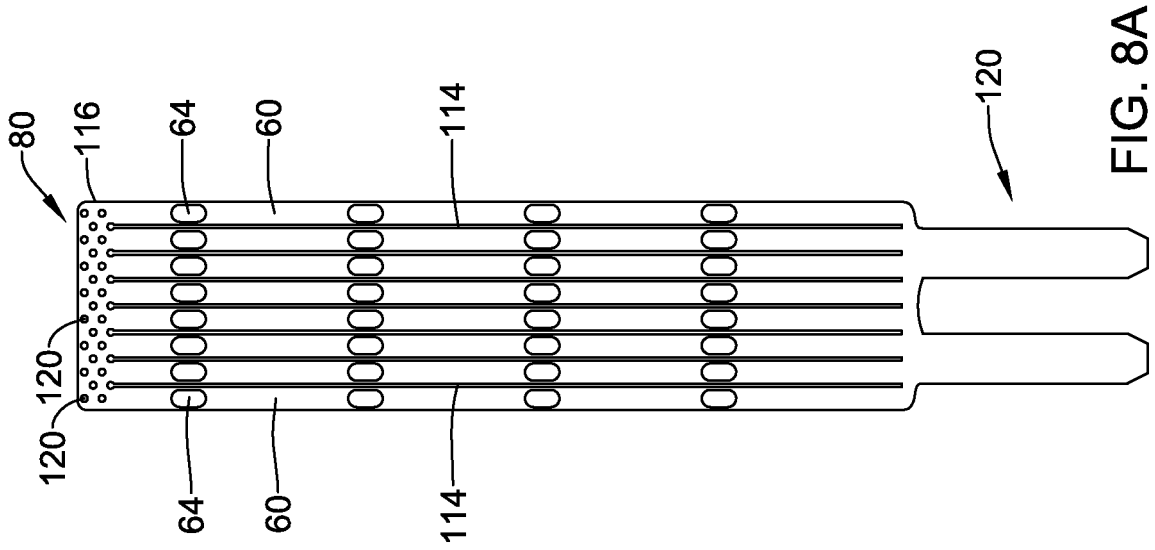

FIG. 8A

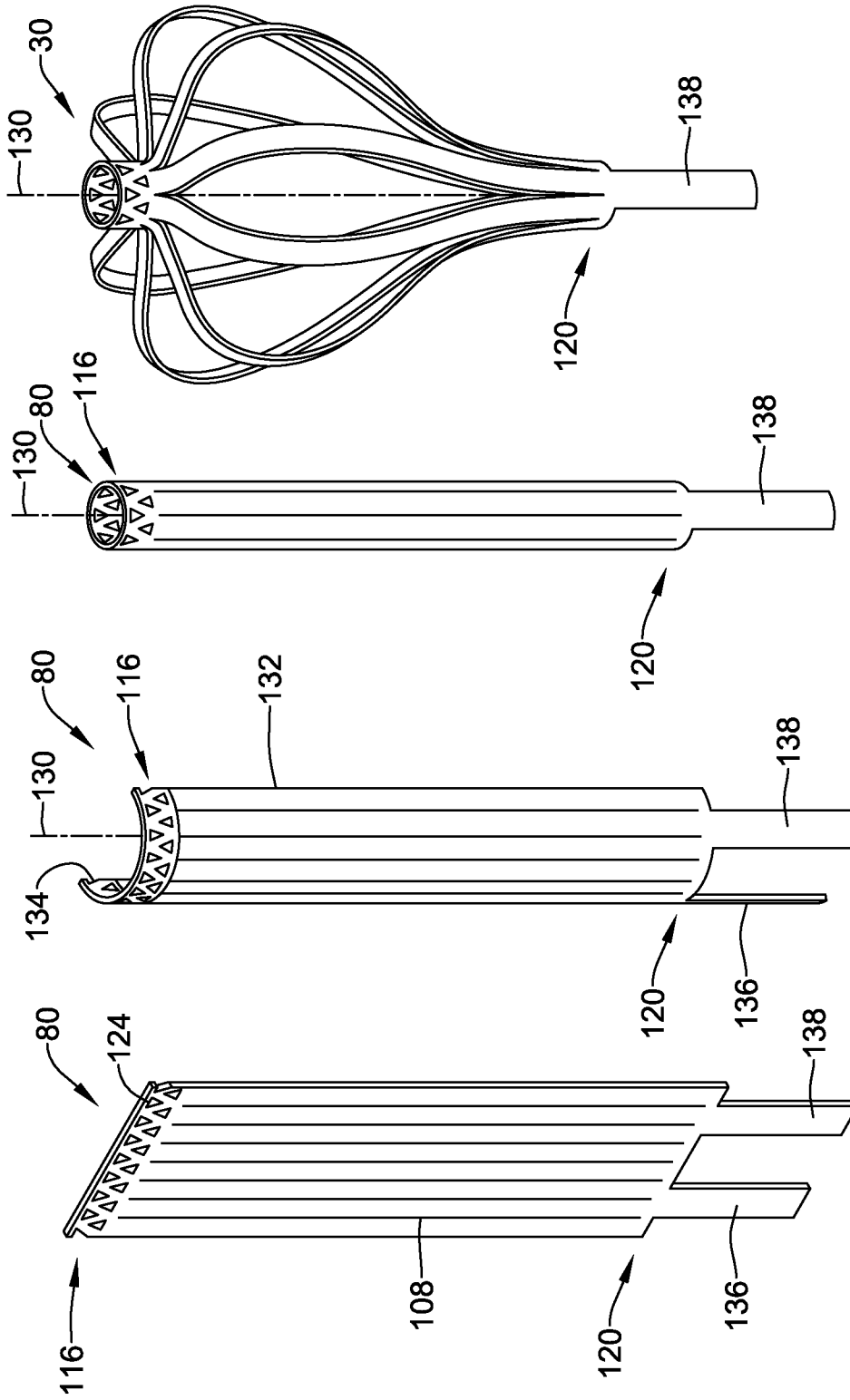

FIG. 9D

FIG. 9C

FIG. 9B

FIG. 9A

**REFERENCES CITED IN THE DESCRIPTION**

*This list of references cited by the applicant is for the reader's convenience only. It does not form part of the European patent document. Even though great care has been taken in compiling the references, errors or omissions cannot be excluded and the EPO disclaims all liability in this regard.*

**Patent documents cited in the description**

- EP 2269505 A1 [0003]
- US 20090299355 A1 [0004]
- WO 9725917 A [0005]
- WO 2014110479 A1 [0006]
- US 2014018880 A1 [0007]

专利名称(译)	电极组装		
公开(公告)号	<a href="#">EP3151773A2</a>	公开(公告)日	2017-04-12
申请号	EP2015736071	申请日	2015-05-27
[标]申请(专利权)人(译)	波士顿科学西美德公司		
申请(专利权)人(译)	BOSTON SCIENTIFIC SCIMED , INC.		
当前申请(专利权)人(译)	BOSTON SCIENTIFIC SCIMED , INC.		
[标]发明人	MARECKI ANDREW T HULTZ PAUL KOZLOWSKI MICHAEL C STEWART BRIAN		
发明人	MARECKI, ANDREW T. HULTZ, PAUL KOZLOWSKI, MICHAEL C. STEWART, BRIAN		
IPC分类号	A61B18/14 A61B5/00 A61B5/0402 A61B5/042 A61B17/00 A61B18/00		
CPC分类号	A61B5/0422 A61B5/6855 A61B5/6856 A61B5/6857 A61B5/6858 A61B5/6859 A61B18/1492 A61B2017/00044 A61B2018/0016 A61B2018/00267 A61B2562/125 A61B2562/164 A61B2562/166 Y10T29/49119 Y10T29/49126		
优先权	62/007716 2014-06-04 US		
其他公开文献	EP3151773B1		
外部链接	<a href="#">Espacenet</a>		

#### 摘要(译)

一种用于心脏标测过程的可扩展电极组件，包括多个双极电极对，包括位于外表面上的第一电极和位于形成可扩展电极组件的各个花键的内表面上的第二电极。这种电极布置可以产生改进的电激活信号，其可以用于产生患者心脏的电活动的更准确的图。