

(19)



(11)

EP 3 092 033 B1

(12)

EUROPEAN PATENT SPECIFICATION

(45) Date of publication and mention of the grant of the patent:
24.04.2019 Bulletin 2019/17

(51) Int Cl.:
A61N 1/36 (2006.01) **A61B 5/0488** (2006.01)
A61B 5/08 (2006.01) **A61F 5/56** (2006.01)
A61B 5/00 (2006.01) **A61N 1/05** (2006.01)

(21) Application number: **15734842.6**

(86) International application number:
PCT/US2015/010367

(22) Date of filing: **06.01.2015**

(87) International publication number:
WO 2015/105811 (16.07.2015 Gazette 2015/28)

(54) **APPARATUS FOR TREATING SLEEP APNEA**

VORRICHTUNG ZUR BEHANDLUNG VON SCHLAFAPNOE

APPAREIL DE TRAITEMENT DE L'APNÉE DU SOMMEIL

(84) Designated Contracting States:
AL AT BE BG CH CY CZ DE DK EE ES FI FR GB GR HR HU IE IS IT LI LT LU LV MC MK MT NL NO PL PT RO RS SE SI SK SM TR

- **HARTER, Laurence Wylie**
Santa Clara, CA 95054 (US)
- **KENT, Harold Byron**
Santa Clara, CA 95054 (US)
- **PULDON, Karena Yadira**
Santa Clara, CA 95054 (US)

(30) Priority: **07.01.2014 US 201414149689**

(43) Date of publication of application:
16.11.2016 Bulletin 2016/46

(74) Representative: **Boult Wade Tennant LLP**
Verulam Gardens
70 Gray's Inn Road
London WC1X 8BT (GB)

(60) Divisional application:
18214728.0

(73) Proprietor: **Invicta Medical, Inc.**
Santa Clara, CA 95054 (US)

(56) References cited:
EP-B1- 1 128 868 **WO-A2-2013/172935**
CA-A1- 2 477 540 **US-A1- 2004 073 272**
US-A1- 2012 192 874 **US-A1- 2012 197 340**
US-A1- 2012 234 331

(72) Inventors:
 • **KENT, Steven Thomas**
Santa Clara, CA 95054 (US)

EP 3 092 033 B1

Note: Within nine months of the publication of the mention of the grant of the European patent in the European Patent Bulletin, any person may give notice to the European Patent Office of opposition to that patent, in accordance with the Implementing Regulations. Notice of opposition shall not be deemed to have been filed until the opposition fee has been paid. (Art. 99(1) European Patent Convention).

DescriptionTECHNICAL FIELD

[0001] The present embodiments relate generally to sleep apnea, and specifically to non-invasive techniques for treating one or more underlying causes of sleep apnea.

BACKGROUND OF RELATED ART

[0002] Obstructive sleep apnea (OSA) is a medical condition in which a patient's upper airway is repeatedly occluded during sleep. These repeated occlusions of the upper airway may cause sleep fragmentation, which in turn may result in sleep deprivation, daytime tiredness, and malaise. More serious instances of OSA may increase the patient's risk for stroke, cardiac arrhythmias, high blood pressure, and/or other disorders.

[0003] OSA may be characterized by the tendency of the soft tissues of the upper airway to collapse during sleep, thereby occluding the upper airway. More specifically, OSA is typically caused by the collapse of the patient's soft palate and/or by the collapse of the patient's tongue (e.g., onto the back of the pharynx), which in turn may obstruct normal breathing.

[0004] There are many treatments available for OSA including, for example, surgery, constant positive airway pressure (CPAP) machines, and the electrical stimulation of muscles associated with moving the tongue. Surgical techniques include tracheotomies, procedures to remove portions of a patient's tongue and/or soft palate, and other procedures that seek to prevent collapse of the tongue into the back of the pharynx. These surgical techniques are very invasive. CPAP machines seek to maintain upper airway patency by applying positive air pressure at the patient's nose and mouth. However, these machines are uncomfortable and may have low compliance rates.

[0005] Some electrical stimulation techniques seek to prevent collapse of the tongue into the back of the pharynx by causing the tongue to protrude forward (e.g., in an anterior direction) during sleep. For one example, U.S. Patent 4,830,008 to Meer discloses an invasive technique in which electrodes are implanted into a patient at locations on or near nerves that stimulate the Genioglossus muscle to move the tongue forward (e.g., away from the back of the pharynx). For another example, U.S. Patent 7,711,438 to Lattner discloses a non-invasive technique in which electrodes, mounted on an intraoral device, electrically stimulate the Genioglossus muscle to cause the tongue to move forward during respiratory inspiration. In addition, U.S. Patent 8,359,108 to McCreery teaches an intraoral device that applies electrical stimulation to the Hypoglossal nerve to contract the Genioglossus muscle, which as mentioned above may prevent tongue collapse by moving the tongue forward during sleep.

[0006] Moving a patient's tongue forward during sleep may cause the patient to wake, which is not desirable. In addition, existing techniques for electrically stimulating the Hypoglossal nerve and/or the Genioglossus muscle may cause discomfort and/or pain, which is not desirable. Further, invasive techniques for electrically stimulating the Hypoglossal nerve and/or the Genioglossus muscle undesirably require surgery and introduce foreign matter into the patient's tissue, which is undesirable.

[0007] Thus, there is a need for a non-invasive treatment for OSA that does not disturb or wake-up the patient during use. An example of existing prior art includes EP 1,128,868, which relates to an intraoral electro-muscular stimulation device, and method to treat a breathing disorder.

SUMMARY

[0008] This Summary is provided to introduce in a simplified form a selection of concepts that are further described below in the Detailed Description. This Summary is not intended to identify key features or essential features of the claimed subject matter, nor is it intended to limit the scope of the claimed subject matter.

[0009] A method and apparatus for reducing the occurrence and/or severity of a breathing disorder, such as OSA, are disclosed herein. In accordance with the present embodiments, a non-invasive and removable oral appliance is disclosed that may provide electrical stimulation to a lateral and/or sublingual portion of a patient's oral cavity (mouth) in a manner that prevents a collapse of the patient's tongue and/or soft palate during sleep without disturbing (e.g., without waking) the patient. For at least some embodiments, an electric current induced by the appliance may stimulate the patient's Palatoglossus muscle in a manner that causes the Palatoglossus muscle to stiffen and shorten, which in turn may pull the patient's soft palate and/or palatal arches in a downward direction towards a base of the patient's tongue so as to prevent the soft palate from collapsing and/or from flapping against the back of the patient's throat. Stiffening and/or shortening the Palatoglossus muscle may also cause the patient's tongue to contract and/or stiffen in a manner that prevents collapse of the tongue in a posterior direction (e.g., towards the patient's pharynx). In addition, stimulating the Palatoglossus muscle using techniques described herein may also lower a superior surface of the tongue T, thereby causing the tongue to cinch downward (e.g., to "hunker down") in a manner that further prevents obstruction of the patient's upper airway. By simultaneously preventing collapse of the patient's soft palate and tongue, patency of the patient's upper airway may be maintained in a non-invasive manner. For some embodiments, the appliance may stimulate the patient's Palatoglossus muscle without moving the patient's tongue in an anterior direction. For at least one embodiment, stimulation of the patient's Palatoglossus muscle may also elevate a posterior portion

of the patient's tongue, which in turn may further prevent collapse of the tongue onto the back of the patient's pharynx.

BRIEF DESCRIPTION OF THE DRAWINGS

[0010] The present embodiments are illustrated by way of example and are not intended to be limited by the figures of the accompanying drawings, where like reference numerals refer to corresponding parts throughout the drawing figures.

FIG. 1A is a side sectional view depicting a patient's upper airway.

FIG. 1B is a front plan view of the patient's oral cavity.

FIG. 1C is an elevated sectional view of the patient's tongue.

FIG. 1D is a side sectional view of the patient's tongue.

FIG. 2A is a top plan view of an oral appliance, situated over a patient's teeth, in accordance with some embodiments.

FIG. 2B is an elevated perspective view of the oral appliance of FIG. 2A.

FIG. 2C is a top plan view of an oral appliance, situated over a patient's teeth, in accordance with other embodiments.

FIG. 2D is an elevated perspective view of the oral appliance of FIG. 2C.

FIG. 3A is a side sectional view depicting a patient's upper airway during disturbed breathing.

FIG. 3B is a side sectional view depicting the patient's upper airway response to electrical stimulation provided in accordance with the present embodiments.

FIG. 4 is a block diagram of the electrical components of the oral appliance of FIGS. 2A-2B.

FIG. 5 is a circuit diagram illustrating an electrical model of the patient's tongue.

FIG. 6 is an illustrative flow chart depicting an exemplary operation in accordance with some embodiments.

FIG. 7A is an elevated perspective view of an oral appliance in accordance with other embodiments.

FIG. 7B is an elevated perspective view of the oral appliance of FIG. 7A situated over a patient's teeth.

FIG. 7C is a rear plan view of the oral appliance of FIG. 7A situated over a patient's teeth.

FIG. 7D is a front plan view of the oral appliance of FIG. 7A situated over a patient's teeth.

DETAILED DESCRIPTION

[0011] A non-invasive method and apparatus for treating sleep disorders, such as obstructive sleep apnea (OSA) and/or snoring, are disclosed herein. In the following description, numerous specific details are set forth to provide a thorough understanding of the present disclosure. Also, in the following description and for purposes of explanation, specific nomenclature is set forth to provide a thorough understanding of the present embodiments. However, it will be apparent to one skilled in the art that these specific details may not be required to practice the present embodiments. In other instances, well-known circuits and devices are shown in block diagram form to avoid obscuring the present disclosure. The term "coupled" as used herein means connected directly to or connected through one or more intervening components, circuits, or physiological matter. Any of the signals provided over various buses described herein may be time-multiplexed with other signals and provided over one or more common buses. Additionally, the interconnection between circuit elements or software blocks may be shown as buses or as single signal lines. Each of the buses may alternatively be a single signal line, and each of the single signal lines may alternatively be buses, and a single line or bus might represent any one or more of a myriad of physical or logical mechanisms for communication between components. Further, the logic levels and timing assigned to various signals in the description below are arbitrary and/or approximate, and therefore may be modified (e.g., polarity reversed, timing modified, etc.) as desired.

[0012] As used herein, the term "substantially lateral direction" refers to a direction across the patient's oral cavity in which the direction's lateral components are larger than the direction's anterior-to-posterior components (e.g., a substantially lateral direction may refer to any direction that is less than approximately 45 degrees from the lateral direction, as defined below with respect to the drawing figures). Further, as used herein, the term "reversible current" means a current that changes or reverses polarity from time to time between two controllable voltage potentials.

[0013] To more fully understand the present embodiments, the dynamics of OSA are first described with respect to an illustration 100 of a patient's oral cavity shown in FIGS. 1A-1D, which illustrate the anatomical elements of a patient's upper airway (e.g., including the nasal cavity, oral cavity, and pharynx of the patient). Referring first

to FIGS. 1A-1B, the hard palate HP overlies the tongue T and forms the roof of the oral cavity OC (e.g., the mouth). The hard palate HP includes bone support BS, and thus does not typically deform during breathing. The soft palate SP, which is made of soft material such as membranes, fibrous material, fatty tissue, and muscle tissue, extends rearward (e.g., in a posterior direction) from the hard palate HP towards the back of the pharynx PHR. More specifically, an anterior end 1 of the soft palate SP is anchored to a posterior end of the hard palate HP, and a posterior end 2 of the soft palate SP is unattached. Because the soft palate SP does not contain bone or hard cartilage, the soft palate SP is flexible and may collapse onto the back of the pharynx PHR and/or flap back and forth (e.g., especially during sleep).

[0014] The pharynx PHR, which passes air from the oral cavity OC and nasal cavity NC into the trachea TR, is the part of the throat situated inferior to (below) the nasal cavity NC, posterior to (behind) the oral cavity OC, and superior to (above) the esophagus ES. The pharynx PHR is separated from the oral cavity OC by the Palatoglossal arch PGA, which runs downward on either side to the base of the tongue T.

[0015] Although not shown for simplicity, the pharynx PHR includes the nasopharynx, the oropharynx, and the laryngopharynx. The nasopharynx lies between an upper surface of the soft palate SP and the wall of the throat (i.e., superior to the oral cavity OC). The oropharynx lies behind the oral cavity OC, and extends from the uvula U to the level of the hyoid bone HB. The oropharynx opens anteriorly into the oral cavity OC. The lateral wall of the oropharynx consists of the palatine tonsil, and lies between the Palatoglossal arch PGA and the Palatopharyngeal arch. The anterior wall of the oropharynx consists of the base of the tongue T and the epiglottic vallecula. The superior wall of the oropharynx consists of the inferior surface of the soft palate SP and the uvula U. Because both food and air pass through the pharynx PHR, a flap of connective tissue called the epiglottis EP closes over the glottis (not shown for simplicity) when food is swallowed to prevent aspiration. The laryngopharynx is the part of the throat that connects to the esophagus ES, and lies inferior to the epiglottis EP.

[0016] Referring also to FIGS. 1C-1D, the tongue T includes a plurality of muscles that may be classified as either intrinsic muscles or extrinsic muscles. The intrinsic muscles, which lie entirely within the tongue T and are responsible for altering the shape of the tongue T (e.g., for talking and swallowing), include the superior longitudinal muscle SLM, the inferior longitudinal muscle ILM, the vertical muscle VM, and the transverse muscle TM. The superior longitudinal muscle SLM runs along the superior surface SS of the tongue T under the mucous membrane, and may be used to elevate, retract, and deviate the tip of the tongue T. The inferior longitudinal muscle ILM lines the sides of the tongue T, and is attached to the Styloglossus muscle SGM. The vertical muscle VM is located along the midline of the tongue T, and

connects the superior and inferior longitudinal muscles together. The transverse muscle TM divides the tongue at the middle, and is attached to the mucous membranes that run along the sides of the tongue T.

[0017] The extrinsic muscles, which attach the tongue T to other structures and are responsible for re-positioning (e.g., moving) the tongue, include the Genioglossus muscle GGM, the Hyoglossus muscle HGM, the Styloglossus muscle SGM, and the Palatoglossus muscle PGM. The Genioglossus muscle GGM may be used to protrude the tongue T and to depress the center of the tongue T. The Hyoglossus muscle HGM may be used to depress the tongue T. The Styloglossus muscle SGM may be used to elevate and retract the tongue T. The Palatoglossus muscle PGM may be used to depress the soft palate SP and/or to elevate the back (posterior portion) of the tongue T. Referring also to FIGS. 1A and 1B, the Palatoglossus muscle PGM connects the tongue T to both sides of the Palatoglossus arch PGA, and inserts into lateral posterior regions 101 of the base of the tongue T.

[0018] It is noted that all of the muscles of the tongue T, except for the Palatoglossus muscle PGM, are innervated by the Hypoglossal nerve (not shown for simplicity); the Palatoglossus muscle PGM is innervated by the pharyngeal branch of the vagus nerve (not shown for simplicity).

[0019] During awake periods, the muscles of the upper airway (as well as the hypoglossal nerve) are active and stimulated, and may maintain upper airway patency by preventing the soft palate SP from collapsing and/or by preventing the tongue T from prolapsing onto the back of the pharynx PHR. However, during sleep periods, a relative relaxed state of the soft palate SP may allow the soft palate SP to collapse and obstruct normal breathing, while a relative relaxed state of the tongue T may allow the tongue T to move in a posterior direction (e.g., onto the back of the pharynx PHR) and obstruct normal breathing.

[0020] Accordingly, conventional electrostimulation treatments for OSA typically involve causing the tongue T to move forward in the anterior direction during apnea episodes so that the tongue T does not collapse in the posterior direction. More specifically, some conventional techniques (e.g., disclosed in U.S. Patents 5,190,053 and 6,212,435) electrically stimulate the Genioglossus muscle to move the tongue forward in an anterior direction during apnea episodes, while other conventional techniques (e.g., disclosed in U.S. Patent 8,359,108) electrically stimulate the Hypoglossal nerve, which in turn causes the tongue to move forward in the anterior direction by innervating the Genioglossus muscle.

[0021] Unfortunately, repeatedly moving the tongue T forward (e.g., in the anterior direction) to prevent its prolapse into the back of the pharynx PHR may undesirably wake-up the patient, which defeats the very purpose of OSA treatments and may also abrade the tongue on the teeth. Indeed, electrically stimulating the relatively large

Genioglossus muscle may cause discomfort or pain. In addition, because the Hypoglossal nerve innervates every tongue muscle except the Palatoglossus muscle PGM, electrically stimulating the Hypoglossal nerve may stimulate not only the Genioglossus muscle GGM but also the superior longitudinal muscle SLM, the inferior longitudinal muscle ILM, the vertical muscle VM, the transverse muscle TM, the Hyoglossus muscle HPM, and/or the Styloglossus muscle SGM. Stimulating multiple tongue muscles at the same time, in an attempt to move the tongue forward during apnea episodes, may not only over-stimulate the patient's tongue muscles but may also cause the tongue T to behave erratically (e.g., repeatedly protruding and retracting). For example, simultaneously stimulating the Genioglossus muscle GGM and the Styloglossus muscle SGM may cause the tongue T to repeatedly protrude and retract, respectively, which is likely to disturb the patient's sleep patterns or even wake-up the patient.

[0022] Applicant has discovered that OSA may be more effectively treated by targeting the Palatoglossus muscle PGM for electrical stimulation (e.g., rather than targeting the Genioglossus muscle GGM or the Hypoglossal nerve for electrical stimulation). More specifically, Applicant has discovered that application of one or more voltage differentials across selected portions of the patient's lateral or sublingual tissue may induce a current across the tongue to electrically stimulate the Palatoglossus muscle PGM in a manner that causes the Palatoglossus muscle PGM to shorten (e.g., to decrease its length). For at least some embodiments, the induced current may flow in a lateral direction across a base portion of the patient's tongue (e.g., proximate to the lateral points at which the Palatoglossus muscle inserts into the tongue T). Shortening the Palatoglossus muscle, using techniques described herein, may (1) stiffen and reduce the volume of the tongue T and (2) may cause the Palatoglossal arch PGA to pull down (e.g., in a downward direction) towards the base of the tongue T.

[0023] As described in more detail below, reducing the volume of the tongue T using techniques described herein may prevent the tongue T from prolapsing onto the back of the pharynx PHR, and pulling down the Palatoglossal arch PGA using techniques described herein may prevent the soft palate SP from collapsing onto the back of the pharynx PHR. In addition, stimulating the Palatoglossus muscle PGM using techniques described herein may also lower the superior surface SS of the tongue T, thereby causing the tongue to cinch downward (e.g., to "hunker down") in a manner that further prevents obstruction of the patient's upper airway.

[0024] Perhaps equally important, because the present embodiments do not target either the Hypoglossal nerve or the Genioglossus muscle GGM for electrical stimulation, the present embodiments may not cause the tongue T to move forward in the anterior direction during application of the electrical stimulation, which in turn may reduce the likelihood of undesirably waking-up the pa-

tient. Indeed, for at least some embodiments, the voltage differential may be applied across the patient's sublingual tissues in a manner that maintains the patient's tongue in a substantially stationary position while shortening the patient's Palatoglossus muscle PGM. In this manner, the present embodiments may maintain a patient's upper airway patency in a subtle yet therapeutic manner. Although electrical stimulation of the Palatoglossus muscle PGM using techniques described herein is not intended to stimulate the Genioglossus muscle GGM, any inadvertent stimulation of the Genioglossus muscle GGM will be relatively small and, at most, may serve to maintain the tongue T in a substantially stationary position.

[0025] FIGS. 2A-2B show a removable oral appliance 200 that, in accordance with at least some embodiments, may be used to treat OSA by using electrical stimulation of the Palatoglossus muscle PGM to prevent collapse of the tongue T and soft palate SP into the back of the pharynx PHR. The appliance 200 is shown in FIGS. 2A-2B as including an appliance body 205 upon which a number of electrodes 210(1)-210(2), a control circuit 220, and a power supply 230 may be mounted (or otherwise attached to) so as to form a unitary and removable device that may fit generally within a patient's oral cavity OC (see also FIGS. 1A-1B). For such embodiments, there are no components external to the patient's body, and therefore the appliance 200 may not be associated with wires or other connectors that protrude from the patient's mouth or body. For some embodiments, the oral appliance 200 may be fitted over a patient's lower teeth and positioned to fit within a sublingual portion of the patient's oral cavity OC, for example, as depicted in FIG. 2A. For other embodiments, appliance 200 may be of other suitable configurations or structures, and the electrodes 210(1)-210(2) may be provided in other suitable positions. For some embodiments, there may be a minor portion of the oral appliance that protrudes slightly outside the lips or mouth.

[0026] Although only two electrodes 210(1)-210(1) are shown in FIGS. 2A-2B, it is to be understood that the appliance 200 may, in other embodiments, include a greater or fewer number of electrodes. For example, in other embodiments, the appliance 200 may include four or another number of electrodes 210 arranged in opposing (e.g., "X") patterns with respect to the patient's sublingual tissues, wherein pairs of the electrodes may be selectively enabled and disabled in a manner that alternately induces two or more currents across the patient's sublingual tissues. For such other embodiments, each of such electrodes may be turned on and/or off independently of the other electrodes, for example, to determine a pair (or more) of electrodes that, at a particular moment for the patient, correlate to optimum electrical stimulation. The determined pair of electrodes may be dynamically selected either by (1) directly correlating electrical stimulation and immediate respiratory response or by (2) indirectly using the oral appliance 200 "to look for" the lowest impedance electrode "pair(s)." The determined elec-

trodes may or may not be at the ends of an "X" pattern, and may be opposing one another.

[0027] The first electrode 210(1) and the second electrode 210(2), which may be formed using any suitable material and may be of any suitable size and/or shape, are connected to the control circuit 220 by wires 221. The control circuit 220 and electrodes 210(1)-210(2) are electrically coupled to power supply 230 via wires 221. Note that the wires 221 may be positioned either within or on an outside surface of the appliance body 205, and therefore do not protrude into or otherwise contact the patient's tongue or oral tissue. The power supply 230 may be mounted in any of several locations and may be any suitable power supply (e.g., a battery) that provides power to control circuit 220 and/or electrodes 210(1)-210(2). Bi-directional gating techniques may be used to control voltages and/or currents within wires 221, for example, so that wires 221 may alternately deliver power to electrodes 210(1)-210(2) and exchange electrical signals (e.g., sensor signals) between electrodes 240(1)-240(2) and control circuit 220.

[0028] For the exemplary embodiment of FIGS. 2A-2B, the first electrode 210(1) may include or also function as a sensor 240(1), and the second electrode 210(2) may include or also function as a sensor 240(2), which could sense respiration or other functions of interest. In other words, for some embodiments, one or both of electrodes 210(1)-210(2) may also function as sensors such as respiration sensors. For such embodiments, the active function of the electrodes 210(1)-210(2) may be controlled using bi-directional gating techniques. For example, when the first electrode 210(1) is to function as a driven electrode, the bi-directional gating technique may connect the first electrode 210(1) to the output of a circuit such as a voltage and/or current driver (e.g., included within or associated with control circuit 220), for example, to provide a first voltage potential at the first electrode 210(1); conversely, when the first electrode 210(1) is to function as the respiration sensor or other sensor 240(1), the bi-directional gating technique may connect sensor 240(1) to the input of a circuit such as an amplifier and/or an ADC (analog to digital) converter (e.g., included within or associated with control circuit 220), for example, to sense a respiratory function of the patient. Similarly, when the second electrode 210(2) is to function as a driven electrode, the bi-directional gating technique may connect the second electrode 210(2) to the output of a circuit such as a voltage and/or current driver (e.g., included within or associated with control circuit 220), for example, to provide a second voltage potential at the second electrode 210(2); conversely, when the second electrode 210(2) is to function as the respiration sensor or other sensor 240(2), the bi-directional gating technique may connect sensor 240(2) to the input of a circuit such as an amplifier and/or an ADC (analog to digital) converter (e.g., included within or associated with control circuit 220), for example, to sense a respiratory function of the patient.

[0029] The respiration sensors or other sensors 240(1)-240(2), as provided within or otherwise associated with the electrodes 210(1)-210(2), may be any suitable sensors that measure any physical, chemical, mechanical, electrical, neurological, and/or other characteristics of the patient which may indicate or identify the presence and/or absence of disturbed breathing. These respiration sensors 240(1)-240(2) may also be used to detect snoring. For at least some embodiments, one or both of electrodes 210(1)-210(2) may include electromyogram (EMG) sensors that, for example, detect electrical activity of the muscles within, connected to, or otherwise associated with the patient's tongue T. For at least one embodiment, one or both of electrodes 210(1)-210(2) may include a microphone (or any other sensor to sense acoustic and/or vibration energy) to detect the patient's respiratory behavior. For other embodiments, one or both of electrodes 210(1)-210(2) may include one or more of the following non-exhaustive list of sensors: accelerometers, piezos, capacitance proximity detectors, capacitive sensing elements, optical systems, EMG sensors, etc.

[0030] For other embodiments, electrodes 210(1)-210(2) may not include any sensors. For at least one of the other embodiments, the electrodes 210(1)-210(2) may continuously provide electrical stimulation to the patient's Palatoglossus muscle PGM via the sublingual tissues. For an alternative embodiment, a timer (not shown for simplicity) may be provided on appliance body 205 or within control circuit 220 and configured to selectively enable/disable electrodes 210(1)-210(2), for example, based upon a predetermined stimulation schedule. In another closed-loop embodiment, the electrodes 210(1)-210(2) may be selectively enabled/disabled based upon one or more sources of sensor feedback from the patient.

[0031] For the exemplary embodiment of FIGS. 2A-2B, the first and second electrodes 210(1)-210(2) may be mounted on respective lateral arms 205(1) and 205(2) of the body 205 of appliance 200 such that when appliance 200 is placed within a sublingual portion of the patient's oral cavity OC, the first and second electrodes 210(1)-210(2) are positioned on opposite sides of the posterior sublingual region 207 of the patient's oral cavity OC. For other embodiments, the first and second electrodes 210(1)-210(2) may be separate from appliance body 205 but connected to respective lateral arms 205(1)-205(2), for example, so as to "float" beneath or on either side of the patient's tongue T, or alternatively oriented so as to be positioned on opposite sides of the superior surface of the tongue T. For some embodiments, the first and second electrodes 210(1)-210(2) are positioned in the posterior sublingual region 207 of the oral cavity OC such that at least a portion of each of the first and second electrodes 210(1)-210(2) is proximal to a molar 209 of the patient. In this manner, the first and second electrodes 210(1)-210(2) may be in physical contact with the patient's sublingual tissues proximate to the lateral posterior regions 101 at which the Palatoglossus muscle

PGM inserts into the tongue T (see also FIGS. 1A-1B). Further, as depicted in FIGS. 2A-2B, the first and second electrodes 210(1)-210(2) may be angularly oriented with respect to the floor of the mouth such that the first and second electrodes 210(1)-210(2) substantially face and/or contact opposite sides of the tongue T proximate to the lateral posterior regions 101 at which the Palatoglossus muscle PGM inserts into the tongue T (see also FIGS. 1A-1B). For other embodiments, the first and second electrodes 210(1)-210(2) may be provided in one or more other positions and/or orientations.

[0032] The control circuit 220 may provide one or more signals to the first and second electrodes 210(1)-210(2) to create a voltage differential across the patient's sublingual tissues (e.g., across the base of the tongue) in the lateral direction. For purposes of discussion herein, the first electrode 210(1) may provide a first voltage potential V1, and the second electrode 210(2) may provide a second voltage potential V2. The voltage differential (e.g., V2-V1) provided between the first and second electrodes 210(1)-210(2) may induce a current 201 in a substantially lateral direction across the patient's sublingual tissues. For some embodiments, the current 201 is induced in a substantially lateral direction across the patient's tongue. The current 201, which for some embodiments may be a reversible current (as described in more detail below), electrically stimulates the patient's Palatoglossus muscle PGM in a manner that shortens the Palatoglossus muscle PGM.

[0033] When the Palatoglossus muscle PGM is stimulated and/or shortened in response to the current 201 induced by the first and second electrodes 210(1)-210(2), the Palatoglossus muscle PGM causes the tongue T to stiffen in a manner that decreases the tongue's volume, and that may also slightly cinch a portion of the tongue T closer to the floor of the oral cavity OC. One or more of decreasing the tongue's volume and slightly cinching the tongue T downward towards the floor of the oral cavity OC may prevent the tongue T from prolapsing onto the back of the pharynx PHR, thereby maintaining patency of the patient's upper airway (e.g., without moving the tongue forward in the anterior direction). The shortening of the Palatoglossus muscle PGM may also pull the patient's Palatoglossal arch PGA in a downward direction towards the base of the tongue T, which in turn may prevent the soft palate SP from collapsing and obstructing the patient's upper airway.

[0034] For example, FIG. 3A shows a side view 300A of a patient depicting the collapse of the patient's tongue T and soft palate SP in a posterior direction towards the back of the pharynx PHR during disturbed breathing. As depicted in FIG. 3A, the patient's upper airway is obstructed by the tongue T prolapsing onto the back wall of the pharynx PHR and/or by the soft palate SP collapsing onto the back wall of the pharynx PHR.

[0035] In contrast, FIG. 3B shows a side view 300B of the patient depicting the patient's upper airway response to electrical stimulation provided in accordance with the

present embodiments. More specifically, electrical stimulation provided by one or more embodiments of the appliance 200 may cause the Palatoglossus muscle PGM to stiffen and shorten, which in turn may pull the patient's soft palate SP and/or palatal arches in a downward direction, thereby preventing the soft palate SP from collapsing onto the back wall of the pharynx PHR. In addition, stiffening and/or shortening the Palatoglossus muscle PGM may also cause the patient's tongue T to contract and/or cinch downward in a manner that prevents collapse of the tongue T towards the back of the pharynx PHR without substantially moving the tongue T forward in the anterior direction.

[0036] The control circuit 220 may be any suitable circuit or device (e.g., a processor) that causes electrical stimulation energy to be provided to areas proximate to the base of the patient's tongue T via the electrodes 210(1)-210(2). More specifically, the control circuit 220 may generate one or more voltage waveforms that, when provided as signals and/or drive signals to the first and second electrodes 210(1)-210(2), primarily induces a current across (e.g., in a substantially lateral direction) the sublingual portion of the patient's tongue T in a manner that causes the patient's Palatoglossus muscle PGM to shorten. The waveforms provided by control circuit 220 may include continuous voltage waveforms, a series of pulses, or a combination of both. The control circuit 220 may be formed using digital components, analog components, or a combination of analog and digital components.

[0037] For some embodiments, the control circuit 220 may vary or modify the waveform in a manner that induces a reversible current across the sublingual portion of the patient's tongue T (e.g., across the base of the tongue). Applicant has discovered that inducing a reversible current across the sublingual portion of the tongue T may decrease the likelihood of patient discomfort (e.g., as compared with providing a constant current or current in a single direction). More specifically, Applicant notes that when a current is induced in the sublingual tissues of the patient, the sublingual tissues may experience carrier depletion, which in turn may require greater voltage differentials and/or greater current magnitudes to maintain a desired level of electrical stimulation of the Palatoglossus muscle PGM. However, inducing greater voltage and/or current magnitudes to offset increasing levels of carrier depletion may create patient discomfort. Thus, to prevent carrier depletion of the patient's sublingual tissues, the control circuit 220 may limit the duration of pulses that induce the current 201 across the sublingual tissues and/or may from time to time reverse the direction (e.g., polarity) of the current 201 induced across the patient's sublingual tissues.

[0038] For some embodiments, control circuit 220 may generate and/or dynamically adjust the waveform and/or drive waveform provided to the first and second electrodes 210(1)-210(2) in response to one or more input signals indicative of the patient's respiratory behavior

and/or inputs from other characteristics and sensing methods. The input signals may be provided by one or more of the sensors 240(1)-240(2) integrated within respective electrodes 210(1)-210(2).

[0039] For other embodiments, sensors other than the sensors 240(1)-240(2) integrated within respective electrodes 210(1)-210(2) may be used to generate the input signals. For example, FIGS. 2C-2D show a removable oral appliance 270 in accordance with other embodiments. Appliance 270 may include all the elements of the appliance 200 of FIGS. 2A-2B, plus additional sensors 240(3)-240(4). For the exemplary embodiment of FIGS. 2C-2D, the sensor 240(3) may be an oxygen saturation (O₂ sat) sensor that provides a signal indicative of the patient's oxygen saturation level, and the sensor 240(4) may be a vibration sensor that provides a signal indicative of the patient's respiratory activity (as measured by vibrations detected within the patient's oral cavity). For other embodiments, sensors 240(3)-240(4) may be other types of sensors including, for example, sensors that measure air composition (especially O₂ and CO₂), heart rate, respiration, temperature, head position, snoring, pH levels, and others.

[0040] FIG. 4 shows a block diagram of the electrical components of an appliance 400 that is one embodiment of the appliance 200 of FIGS. 2A-2B. Appliance 400 is shown to include a processor 410, a plurality of electrodes 210(1)-210(n), power supply 230, sensors 240, and an optional transceiver 420. Processor 410, which is one embodiment of the control circuit 220 of FIGS. 2A-2B, includes a waveform generator 411, a memory 412, and a power module 413. The power supply 230, which as mentioned above may be any suitable power supply (e.g., a battery), provides power (PWR) to processor 410. For some embodiments, the processor 410 may use power module 413 to selectively provide power to sensors 240, for example, only during periods of time that the sensors 240 are to be active (e.g., only when it is desired to receive input signals from sensors 240). Selectively providing power to sensors 240 may not only reduce power consumption (thereby prolonging the battery life of power supply 230) but may also minimize electrical signals transmitted along wires 221 to the processor 410. For other embodiments, power supply 230 may provide power directly to sensors 240.

[0041] The sensors 240, which may include sensors 240(1)-240(2) of FIGS. 2A-2B and/or sensors 240(3)-240(4) of FIGS. 2C-2D, may provide input signals to processor 410. The input signals may be indicative of the respiratory behavior or other functions of the patient and may be used to detect the presence and/or absence of disturbed breathing, for example, as described above with respect to FIGS. 2A-2D.

[0042] The processor 410 may receive one or more input signals from sensors 240, or sensors located elsewhere, and in response thereto may provide signals and/or drive signals (DRV) to a number of the electrodes 210(1)-210(n). As described above, the signals and/or

drive signals (e.g., voltage and/or current waveforms) generated by waveform generator 411 may cause one or more of the electrodes 210(1)-210(n) to electrically stimulate sublingual portions of the patient's oral cavity OC in a manner that shortens the patient's Palatoglossus muscle PGM. Shortening the Palatoglossus muscle PGM in response to electrical stimulation provided by one or more of the electrodes 210(1)-210(n) may (1) stiffen and reduce the volume of the tongue T, (2) may cause the tongue to cinch downward, and (3) may cause the Palatoglossal arch PGA to pull down (e.g., in a downward direction) towards the base of the tongue T. In this manner, the electrical stimulation provided by the one or more electrodes 210(1)-210(n) may prevent the tongue T from prolapsing onto the back of the pharynx PHR and/or may prevent the soft palate SP from collapsing onto the back of the pharynx PHR.

[0043] As mentioned above, the waveforms generated by the waveform generator 411, when provided as signals and/or drive signals to the electrodes 210(1)-210(n), primarily induce a current across the patient's sub-lingual tissues in a manner that causes the patient's Palatoglossus muscle PGM to shorten. The waveforms generated by the waveform generator 411 may include continuous (analog) voltage waveforms, any number of pulses that may vary in shape and duration as a pulse train, or the pulses may be combined to simulate an analog waveform or a combination of both, and may be dynamically modified by the waveform generator 411.

[0044] The optional transceiver 420 may be used to transmit control information (CTL) and/or data, and/or receive control information and/or data from an external device via a suitable wired or wireless connection. The external device (not shown for simplicity) may be any suitable display device, storage device, distribution system, transmission system, and the like. For one example, the external device may be a display (e.g., to display the patient's respiratory behavior or patterns, to alert an observer to periods of electrical stimulation, to indicate an alarm if breathing stops, and so on).

[0045] For another example, the external device may be a storage device that stores any data produced by appliance 200, perhaps including the patient's respiratory behavior, the electrical stimulation provided by appliance 200, the waveforms provided by waveform generator 411, and/or relationships between two or more of the above. More specifically, for some embodiments, the external device may store data for a plurality of patients indicating, for example, a relationship between the application of electrical stimulation to the patient and the patient's respiratory response to such electrical stimulation, and may include other information. Such relationship data for large numbers of patients may be aggregated, and thereafter used to identify trends or common components of OSA across various population demographics. The storage device may be a local storage device, or may be a remote storage device (e.g., accessible via one or more means and/or networks including but not

limited to such as a wide area network (WAN), a wireless local area network (WLAN), a virtual private network (VPN), and/or the Internet). The data and information may be made available and/or manipulated locally and/or remotely, and may be utilized immediately and/or preserved for later utilization and/or manipulation.

[0046] Memory 412 may include a non-transitory computer-readable storage medium (e.g., one or more non-volatile memory elements, such as EPROM, EEPROM, Flash memory, a hard drive, etc.) that may store the following software modules and/or information:

- a function select module to selectively switch an active function of the electrodes 210 between an electrode mode (e.g., provided by one or more of electrodes 210 and a sensor mode (e.g., provided by one or more of sensors 240);
- a control module to selectively provide signals and/or drive signals to the electrodes 210, for example, to induce an electric current across a portion of the patient's oral cavity in accordance with the present embodiments and/or to receive input signals from the sensors 240; and
- a data collection module to record data indicative of the patient's respiratory or other behavior and/or to transmit such data to an external device.

[0047] Each software module may include instructions that, when executed by the processor 410, may cause appliance 400 to perform the corresponding function. Thus, the non-transitory computer-readable storage medium of memory 412 may include instructions for performing all or a portion of the operations described below with respect to FIG. 6. The processor 410 may be any suitable processor capable of executing scripts of instructions of one or more software programs stored in the appliance 400 (e.g., within memory 412). For at least some embodiments, memory 412 may include or be associated with a suitable volatile memory, for example, to store data corresponding to the patient's respiratory functions and/or corresponding to the electrical stimulation provided by the appliance 200.

[0048] As mentioned above, the control circuit 220 may control the duration of pulses that induce the current 201 across the patient's sublingual tissues, for example, to minimize carrier depletion within the patient's sublingual tissues and/or may from time to time reverse the direction of the induced current 201, for example, to provide a zero sum drive waveform (e.g., to minimize or preclude electrochemical activity and/or to minimize the patient's awareness of any electrical activity related to oral appliance 200). For at least one embodiment, the control circuit 220 may select the pulse lengths based upon a resistive-capacitive (RC) time constant model of the patient's tongue T. For example, FIG. 5 shows an RC time constant model 500 of the patient's tongue T. The model

500 is shown to include a capacitor C and two resistors, R1 and R2. For an exemplary embodiment, the capacitor C may be approximately 0.5uF, the resistor R1 may be approximately 600 ohms, and the resistor R2 may be approximately 4,000 ohms. Thus, for the exemplary embodiment, the time constant $\tau = R1 * C$ may be a value approximately equal to 300μs. The resistor R2 represents minor "DC current" flow in the model, where the current stabilizes at a small but non-zero value after more than 5 time constants or when DC is applied to the electrodes.

[0049] More specifically, Applicant has discovered that a typical patient's tongue T is most receptive to a current "pulse duration" that is equal to or shorter than a time period approximately equal to $\tau = R1 * C \approx 300\mu s$. After the time period $3\tau \approx 1ms$ expires, the patient's tongue T may exhibit an even greater increase in impedance, or perhaps experience carrier depletion, which in turn requires greater voltage levels to continue inducing the current 201 across the patient's sublingual tissues. As noted above, increasing the voltage levels to continue inducing the current 201 across the patient's sublingual tissues may not only waste battery or wired power but also may cause discomfort (or even pain) to the patient. Indeed, because current regulators typically utilize their available voltage "headroom" to increase the drive voltage and maintain a constant current flow when the load impedance increases or when the effective drive voltage otherwise decreases, it is important to dynamically manage the effective drive voltage provided by the electrodes 210(1)-210(2).

[0050] The effective drive voltage may decrease when there is an increased impedance, or perhaps carrier depletion, in the patient's tongue, and the drive resistance may increase when one (or both) of the electrodes 210(1)-210(2) loses contact with the patient's sublingual tissues, generally causing the control circuit 220 to increase its drive voltage in an attempt to maintain a prescribed current flow. Thus, for at least some embodiments, the control circuit 220 may be configured to limit the drive voltage and/or the current to levels that are known to be safe and comfortable for the patient, even if the drive impedance becomes unusually high. In addition, the control circuit 220 may be configured to from time to time reverse the polarity or direction of the induced current 201. The reversal of the current 201 can be performed at any time. The timing of the reversal of current 201 may be selected such that there is no net transfer of charge across the patient's sublingual tissues (e.g., a zero sum waveform).

[0051] FIG. 6 is a flow chart 600 depicting an exemplary operation for providing electrical stimulation to a patient in accordance with the present embodiments. Although the flow chart 600 is discussed below with respect to appliance 200 of FIGS. 2A-2B, the flow chart 600 is equally applicable to other embodiments discussed herein. Prior to operation, the appliance 200 is positioned within a sublingual portion of the patient's oral cavity, for example,

so that the electrodes 210(1)-210(2) are positioned on opposite sides of the patient's tongue proximate to the lateral posterior regions 101 at which the Palatoglossus muscle PGM inserts into the tongue T (see also FIGS. 1A-1B). Once the appliance 200 is properly fitted within the patient's oral cavity, the appliance 200 accepts zero or more input signals using a number of sensing circuits provided on or otherwise associated with appliance 200 (601). As discussed above, the input signals may be indicative of the respiratory state or other behavior of the patient, and may be derived from or generated by any suitable sensor. The control circuit 220 generates a number of control and/or drive signals based on the input signals. (602).

[0052] In response to the signals and/or drive signals, the electrodes 210(1)-210(2) induce a current in a lateral direction across a sublingual portion of the patient's tongue (603). The current induced across the sublingual portion of the patient's tongue electrically stimulates the patient's Palatoglossus muscle (604). As described above, electrically stimulating the patient's Palatoglossus muscle may shorten the Palatoglossus muscle (604A), may pull down the patient's soft palate towards the base of the tongue (604B), may decrease the volume of the tongue (604C), and/or may prevent anterior movement of the tongue (604D).

[0053] For some embodiments, the induced current may be a reversible current. For at least one embodiment, the reversible current may be a zero-sum waveform. For such embodiments, the control circuit 220 may from time to time reverse a polarity of the reversible current (605), and/or may adjust the duration and/or amplitude of voltage and/or current pulses and/or waveforms based on the RC time constant model of the patient's tongue (606).

[0054] FIGS. 7A-7D show a removable oral appliance 700 in accordance with other embodiments. The oral appliance 700, which may be used to treat OSA by providing electrical stimulation to a patient's sublingual tissues in a manner that causes the Palatoglossus muscle to shorten, is shown to include an appliance body 705 (which includes portions 705(1)-703(3), as shown in the FIGS.) upon which electrodes 210(1)-210(2), control circuit 220, and power supply 230 may be mounted (or otherwise attached to) so as to form a unitary and removable device that may fit entirely within a patient's oral cavity OC (see also FIGS. 1A-1B). The oral appliance 700, which may operate in a similar manner as the oral appliance 200 of FIGS. 2A-2B, includes appliance body 705 instead of appliance body 205 of FIGS. 2A-2B. Specifically, appliance body 705 includes two anchor portions 705(1)-705(2) and a support wire 705(3). The anchor portions 705(1)-705(2) may be fitted over opposite or approximately opposite molars of the patient, with the support wire 705(3) connected between anchor portions 705(1)-705(2) and extending along the patient's gum line.

[0055] More specifically, for the exemplary embodiments described herein, the first electrode 210(1) may be attached to or otherwise associated with the first an-

chor portion 705(1), and the second electrode 210(2) may be attached to or otherwise associated with the second anchor portion 705(2). The control circuit 220 may be attached to support wire 705(3) and/or the second anchor portion 705(2), and the power supply 230 may be attached to support wire 705(3) and/or the first anchor portion 705(1) and/or the second anchor portion 705(2). Wires 221 (not shown in FIGS. 7A-7D for simplicity) may be attached to or provided within the support wire 705(3).

[0056] In the foregoing specification, the present embodiments have been described with reference to specific exemplary embodiments thereof. It will, however, be evident that various modifications and changes may be made thereto without departing from the broader scope of the disclosure as set forth in the appended claims. The specification and drawings are, accordingly, to be regarded in an illustrative sense rather than a restrictive sense.

Claims

1. A device configured to provide electrical stimulation to an oral cavity (OC) of a patient, the device comprising:

an appliance (200) configured to fit within the oral cavity (OC); and

a number of electrodes (210), coupled to the appliance (200) and adapted to be positioned on opposite sides of the patient's tongue (T), configured to induce a current in a lateral direction across the tongue (T), the electrical stimulation configured to target a palatoglossus muscle (PGM) of the patient;

wherein the device further comprises a control circuit, coupled to the appliance, to generate a signal, wherein the electrodes are responsive to the signal; a power supply (230), mounted on the appliance (200), to provide power to the control circuit (220); wherein the appliance (200), the electrodes (210), the control circuit (220), and the power supply (230) comprise a unitary device adapted to fit entirely within the patient's oral cavity (OC).

2. The device of claim 1, wherein the number of electrodes (210) are configured to induce the current by providing a voltage differential across the tongue (T).

3. The device of claim 1, wherein at least a portion of two of the electrodes (210) are adapted to be positioned posterior to a last molar location of the patient.

4. The device of claim 1, wherein the number of electrodes (210) are adapted to be in physical contact with lateral points at which the Palatoglossus muscle (PGM) inserts into the tongue (T).

5. The device of claim 1, wherein the induced current comprises one or more reversible currents configured to flow in one or more substantially lateral directions across the tongue (T).
6. The device of claim 5, wherein at least one of the reversible currents comprises a zero-sum waveform.
7. The device of claim 5, wherein a pulse length of at least one of the reversible currents is configured according to a resistive-capacitive (RC) time constant model associated with the tongue (T).
8. The device of claim 1, wherein the induced current is configured to shorten the Palatoglossus muscle (PGM) without targeting the patient's Hypoglossal nerve.
9. The device of claim 1, wherein the induced current is configured to pull the patient's Palatoglossal arch (PGA) in a downward direction towards a base of the tongue (T).
10. The device of claim 1, wherein the induced current is configured to decrease a volume of the tongue (T) without moving the tongue (T) in an anterior direction.
11. The device of claim 1, wherein at least one of the electrodes (210) comprises a respiration sensor (240).

Patentansprüche

1. Vorrichtung, die konfiguriert ist, um eine elektrische Stimulation einer Mundhöhle (OC) eines Patienten bereitzustellen, wobei die Vorrichtung Folgendes umfasst:

eine Vorrichtung (200), die konfiguriert ist, um in die Mundhöhle (OC) zu passen; und
 eine Anzahl von Elektroden (210), die mit dem Gerät (200) gekoppelt und dazu ausgelegt sind, auf gegenüberliegenden Seiten der Zunge (T) des Patienten positioniert zu werden, die dazu ausgelegt sind, einen Strom in einer Lateralrichtung über die Zunge (T) zu induzieren, wobei die elektrische Stimulation dazu ausgelegt ist, sich auf einen Palatoglossus-Muskel (PGM) des Patienten zu richten;
 wobei die Vorrichtung ferner eine Steuerschaltung umfasst, die mit dem Gerät gekoppelt ist, um eine Signal zu erzeugen, wobei die Elektroden auf das Signal reagieren; eine Stromversorgung (230), die an dem Gerät (200) montiert ist, um die Steuerschaltung (220) mit Strom zu versorgen; wobei das Gerät (200), die Elektroden

(210), die Steuerschaltung (220) und die Stromversorgung (230) eine einheitliche Vorrichtung umfassen, die ausgelegt ist, um vollständig in die Mundöffnung (OC) des Patienten zu passen.

5

10

15

20

25

30

35

40

45

50

55

2. Vorrichtung nach Anspruch 1, wobei die Anzahl der Elektroden (210) konfiguriert ist, um den Strom durch Bereitstellen einer Spannungsdifferenz über der Zunge (T) zu induzieren.
3. Vorrichtung nach Anspruch 1, wobei mindestens ein Teil von zwei der Elektroden (210) dazu ausgelegt ist, um posterior zu einer letzten molaren Position des Patienten positioniert zu werden.
4. Vorrichtung nach Anspruch 1, wobei die Anzahl der Elektroden (210) so ausgelegt ist, dass sie in physischem Kontakt mit den Lateralpunkten steht, an denen der Palatoglossus-Muskel (PGM) in die Zunge (T) übergeht.
5. Vorrichtung nach Anspruch 1, wobei der induzierte Strom einen oder mehrere reversible Ströme umfasst, die konfiguriert sind, um in einer oder mehreren im Wesentlichen lateralen Richtungen über die Zunge (T) zu fließen.
6. Vorrichtung nach Anspruch 5, wobei mindestens einer der reversiblen Ströme eine Nullsummenwellenform umfasst.
7. Vorrichtung nach Anspruch 5, wobei eine Impulslänge von mindestens einem der reversiblen Ströme gemäß einem der Zunge (T) zugeordneten resistivkapazitiven (RC) Zeitkonstantenmodell konfiguriert ist.
8. Vorrichtung nach Anspruch 1, wobei der induzierte Strom konfiguriert ist, um den Palatoglossus-Muskel (PGM) zu verkürzen, ohne auf den Hypoglossus-Nerv des Patienten zu zielen.
9. Vorrichtung nach Anspruch 1, wobei der induzierte Strom konfiguriert ist, um den Palatoglossalbogen (PGA) des Patienten in eine Abwärtsrichtung zu einer Basis der Zunge (T) zu ziehen.
10. Vorrichtung nach Anspruch 1, wobei der induzierte Strom konfiguriert ist, um ein Volumen der Zunge (T) zu verringern, ohne die Zunge (T) in eine vordere Richtung zu bewegen.
11. Vorrichtung nach Anspruch 1, wobei mindestens eine der Elektroden (210) einen Atmungssensor (240) umfasst.

Revendications

1. Dispositif configuré pour fournir une stimulation électrique à une cavité buccale (OC) d'un patient, le dispositif comprenant :
- un appareil (200) configuré pour s'ajuster dans la cavité buccale (OC) ; et
un certain nombre d'électrodes (210), couplées à l'appareil (200) et adaptées pour être positionnées sur les côtés opposés de la langue (T) du patient, configurées pour induire un courant dans une direction latérale à travers la langue (T), la stimulation électrique étant configurée pour cibler un muscle palatoglosse (PGM) du patient ;
dans lequel le dispositif comprend en outre un circuit de commande, couplé à l'appareil, pour générer un signal, dans lequel les électrodes sont sensibles au signal ; une alimentation électrique (230) montée sur l'appareil (200) pour alimenter le circuit de commande (220) ; dans lequel l'appareil (200), les électrodes (210), le circuit de commande (220) et l'alimentation (230) comprennent un dispositif unitaire adapté pour s'ajuster entièrement dans la cavité buccale du patient.
2. Dispositif selon la revendication 1, dans lequel le certain nombre d'électrodes (210) est configuré pour induire le courant en fournissant un différentiel de tension à travers la langue (T).
3. Dispositif selon la revendication 1, dans lequel au moins une partie de deux des électrodes (210) est adaptée pour être positionnée en arrière d'un emplacement de dernière molaire du patient.
4. Dispositif selon la revendication 1, dans lequel le certain nombre d'électrodes (210) est adapté pour être en contact physique avec des points latéraux au niveau desquels le muscle palatoglosse (MGP) s'insère dans la langue (T).
5. Dispositif selon la revendication 1, dans lequel le courant induit comprend un ou plusieurs courants réversibles configurés pour circuler dans une ou plusieurs directions sensiblement latérales à travers la langue (T).
6. Dispositif selon la revendication 5, dans lequel au moins l'un des courants réversibles comprend une forme d'onde à somme nulle.
7. Dispositif selon la revendication 5, dans lequel une longueur d'impulsion d'au moins l'un des courants réversibles est configurée selon un modèle de constante de temps résistif-capacitif (RC) associé à la langue (T).
8. Dispositif selon la revendication 1, dans lequel le courant induit est configuré pour raccourcir le muscle palatoglosse (PGM) sans cibler le nerf hypoglosse du patient.
9. Dispositif selon la revendication 1, dans lequel le courant induit est configuré pour tirer l'arc palatoglosse (PGA) du patient dans une direction descendante vers une base de la langue (T).
10. Dispositif selon la revendication 1, dans lequel le courant induit est configuré pour diminuer un volume de la langue (T) sans déplacer la langue (T) dans une direction antérieure.
11. Dispositif selon la revendication 1, dans lequel au moins l'une des électrodes (210) comprend un capteur de respiration (240).

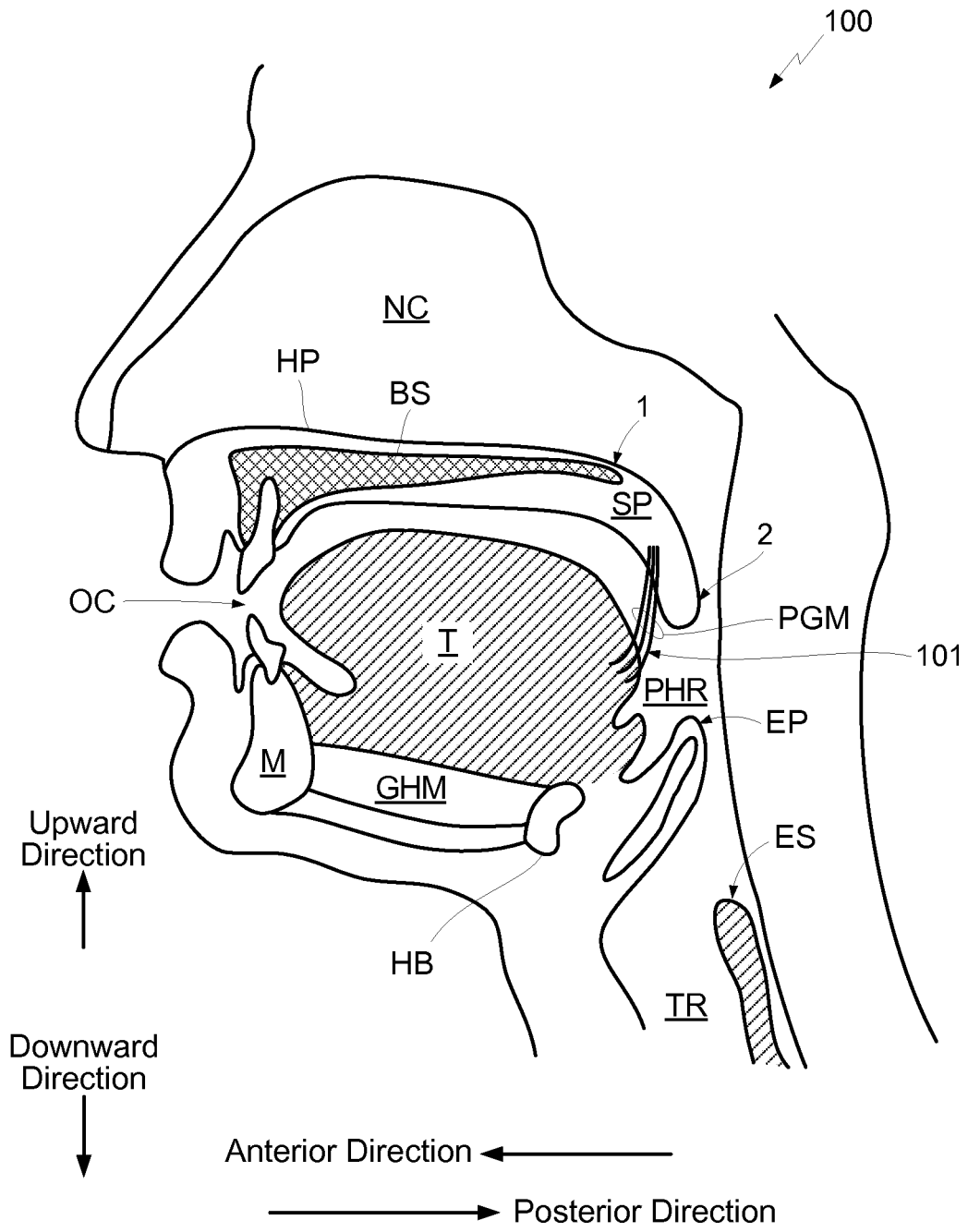

FIG. 1A

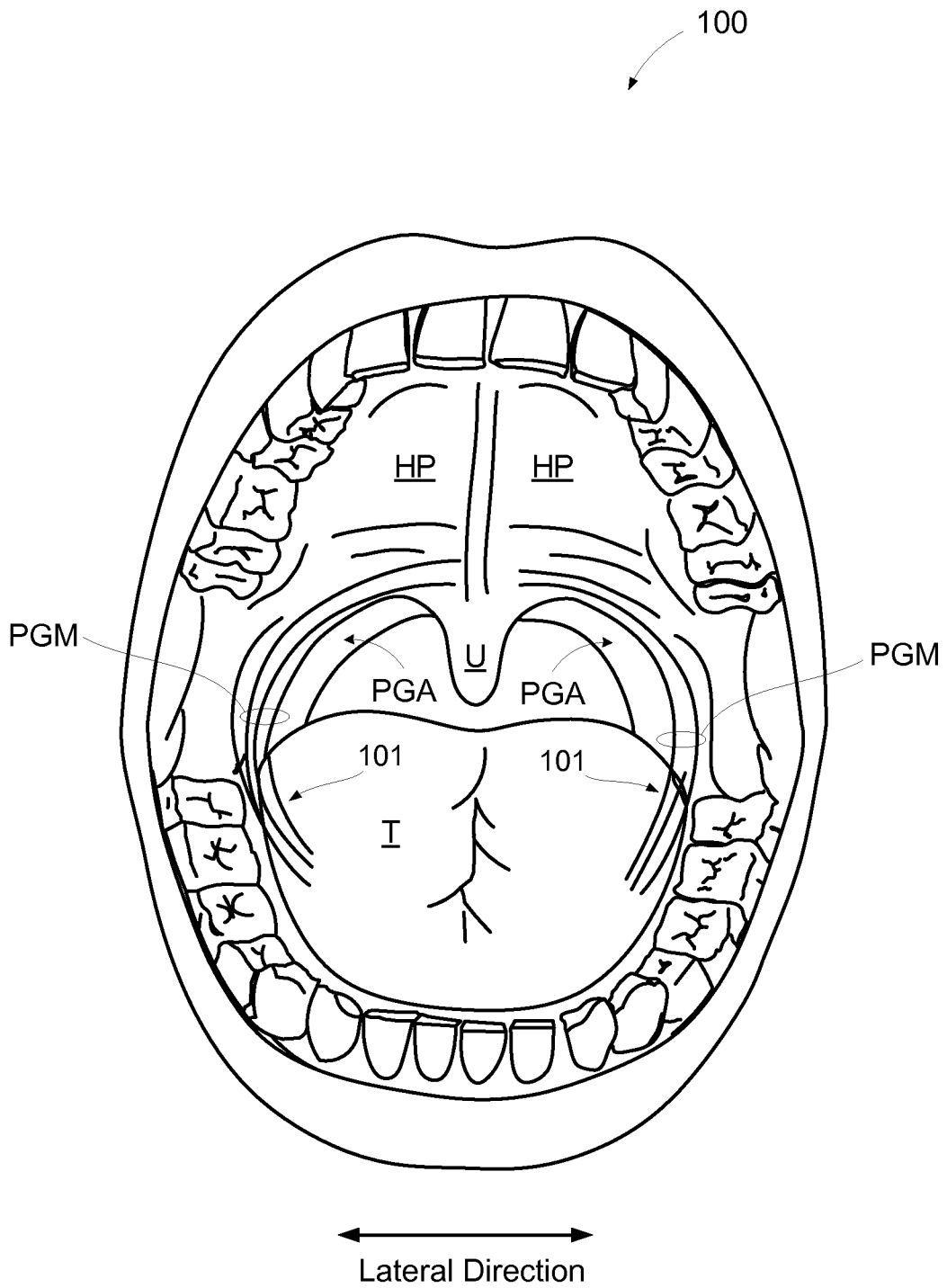

FIG. 1B

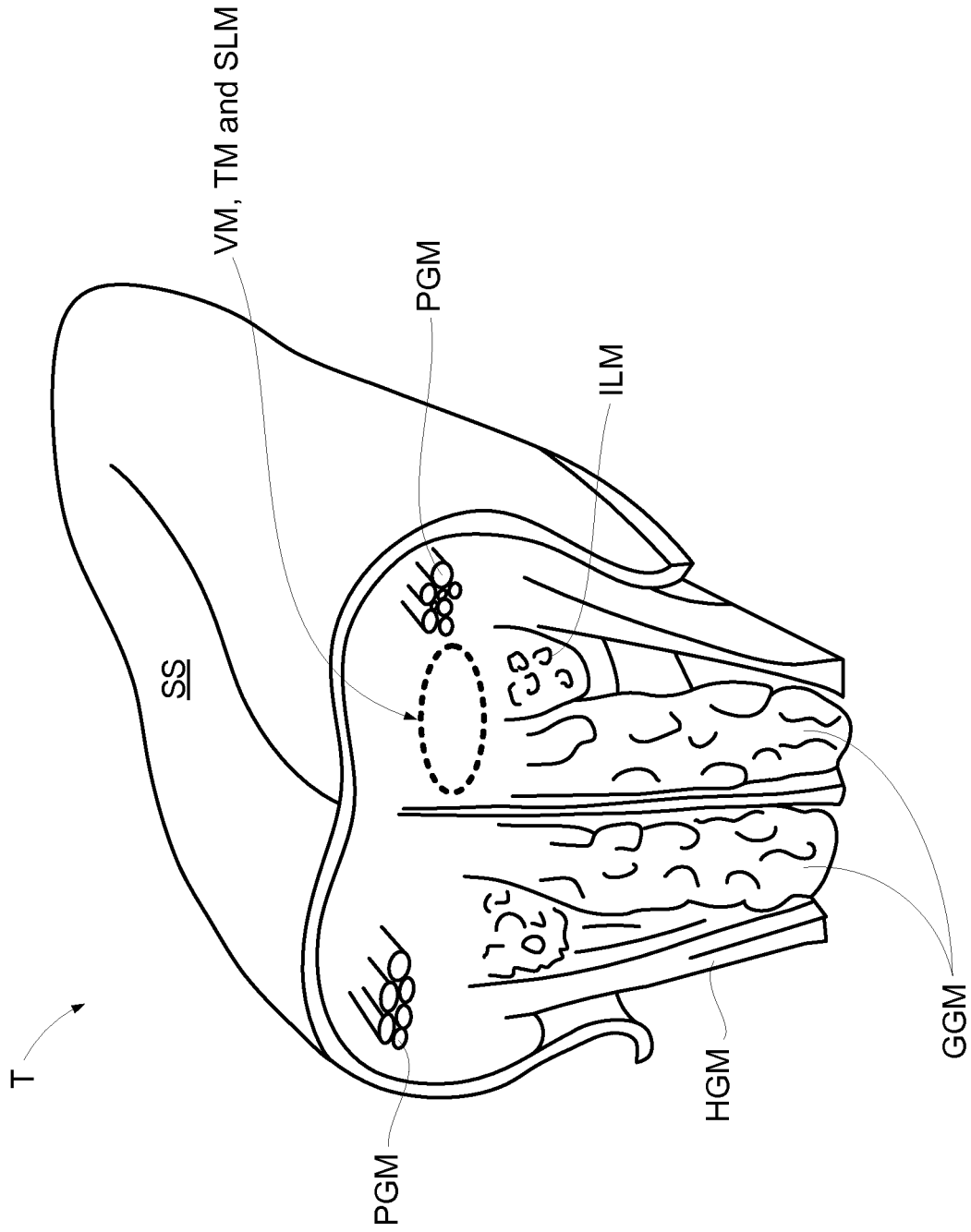

FIG. 1C

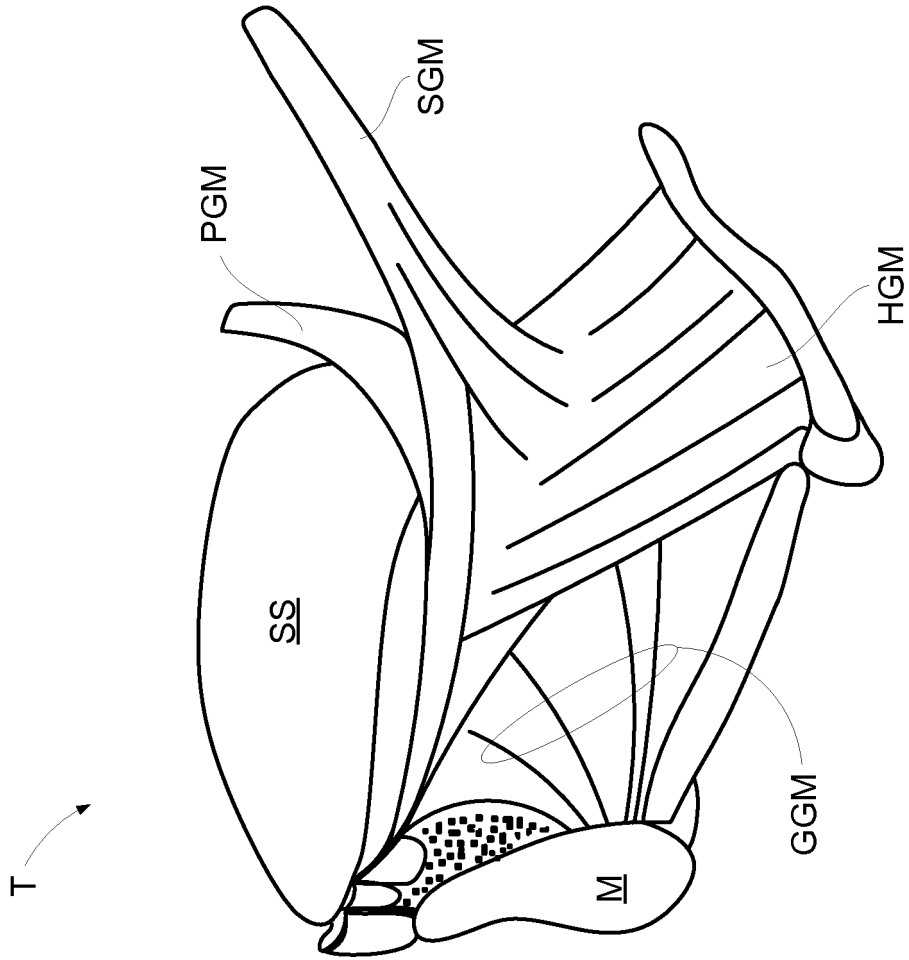

FIG. 1D

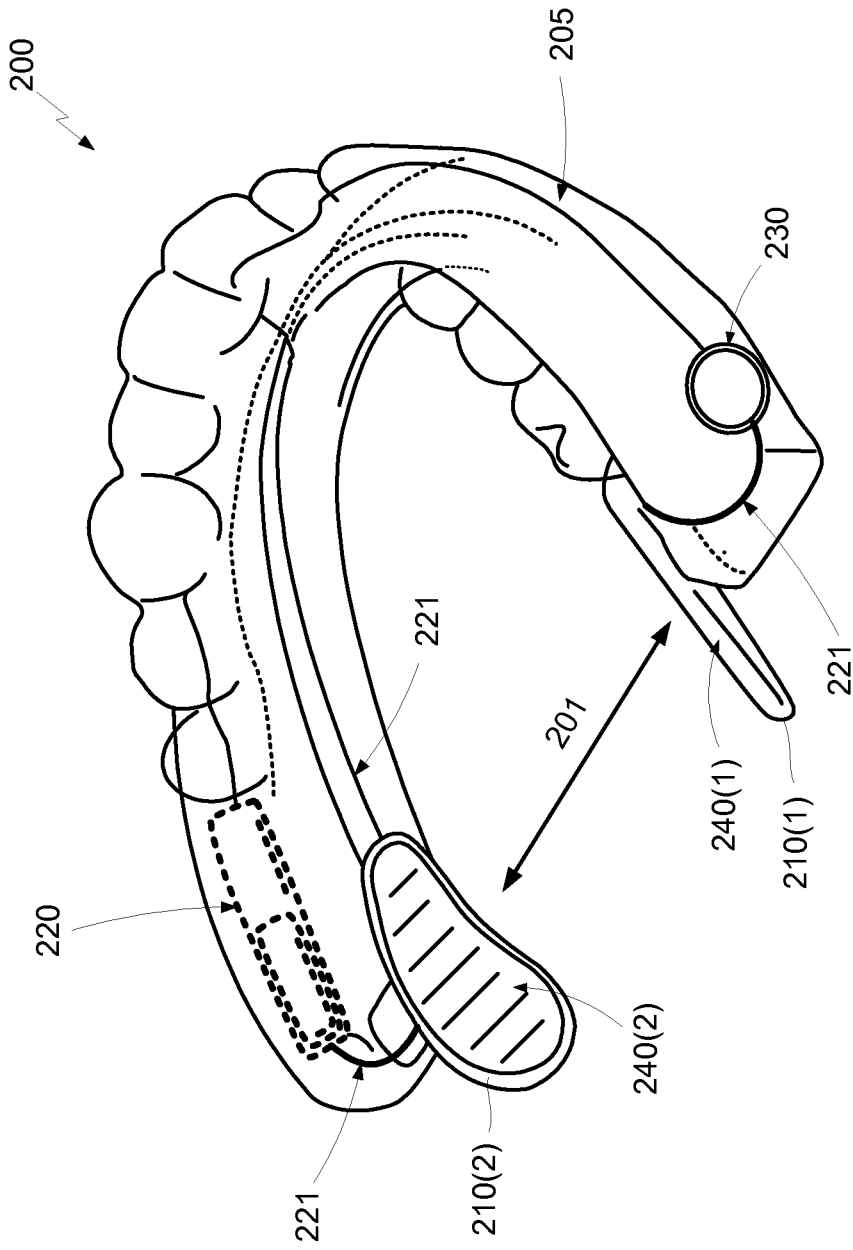

FIG. 2B

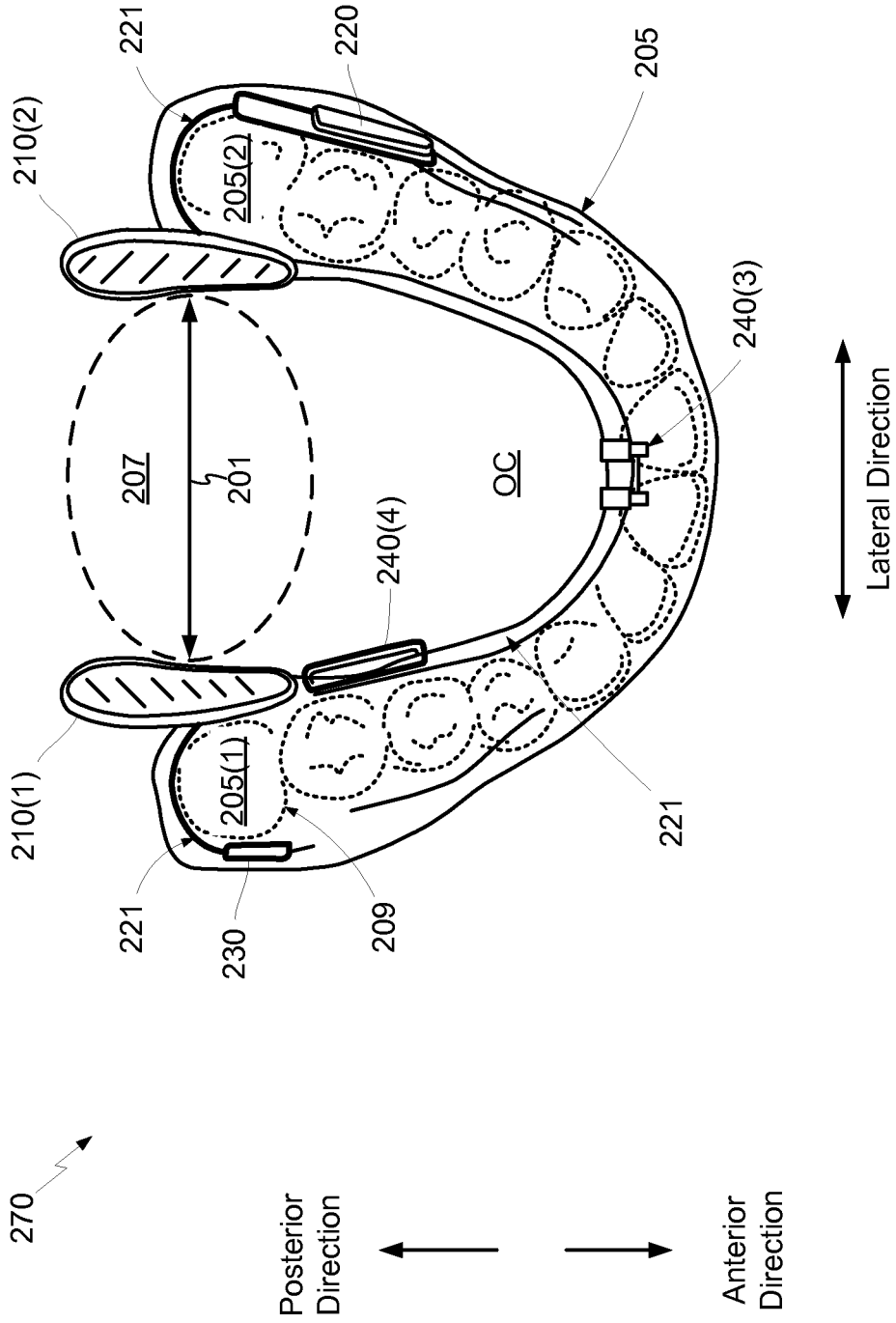

FIG. 2C

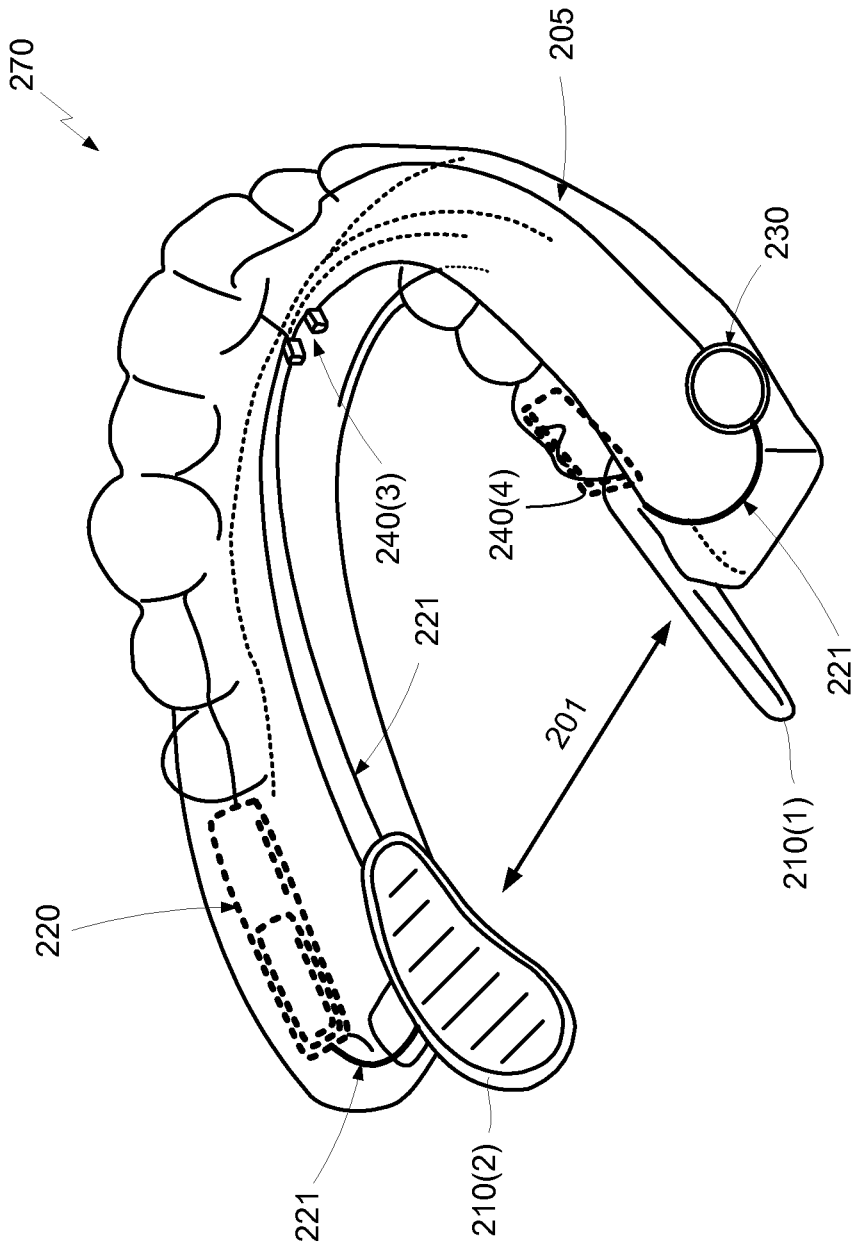

FIG. 2D

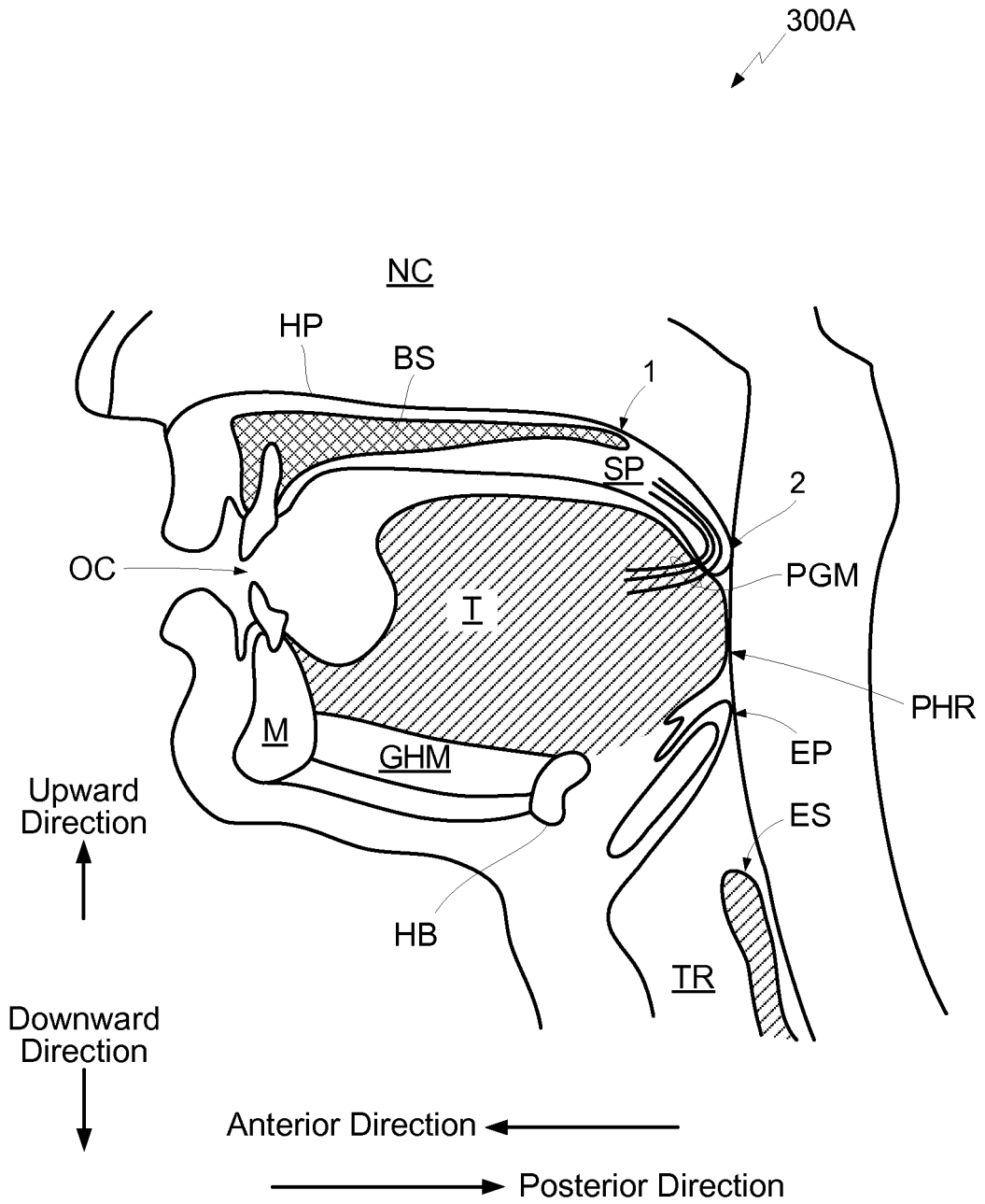

FIG. 3A

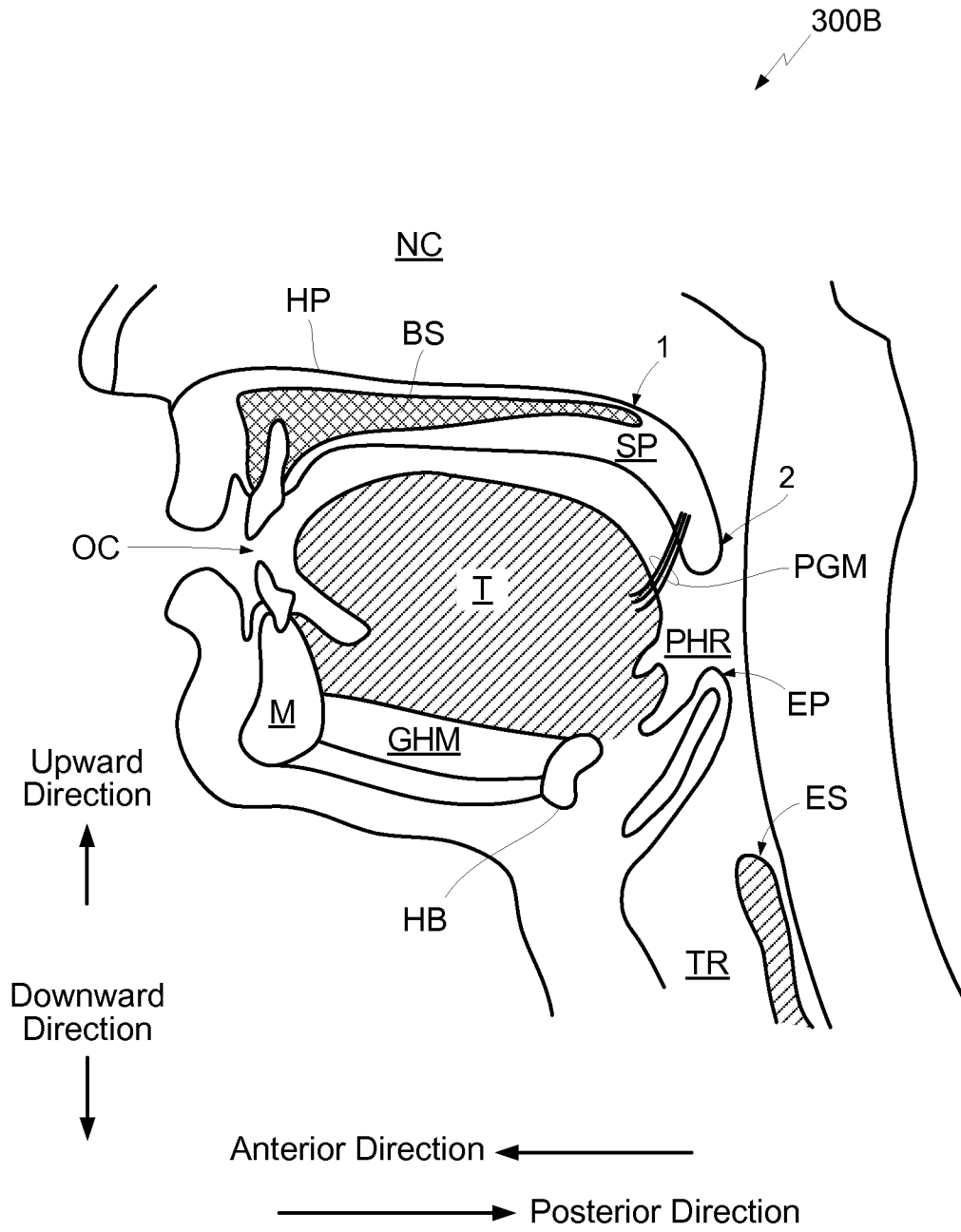

FIG. 3B

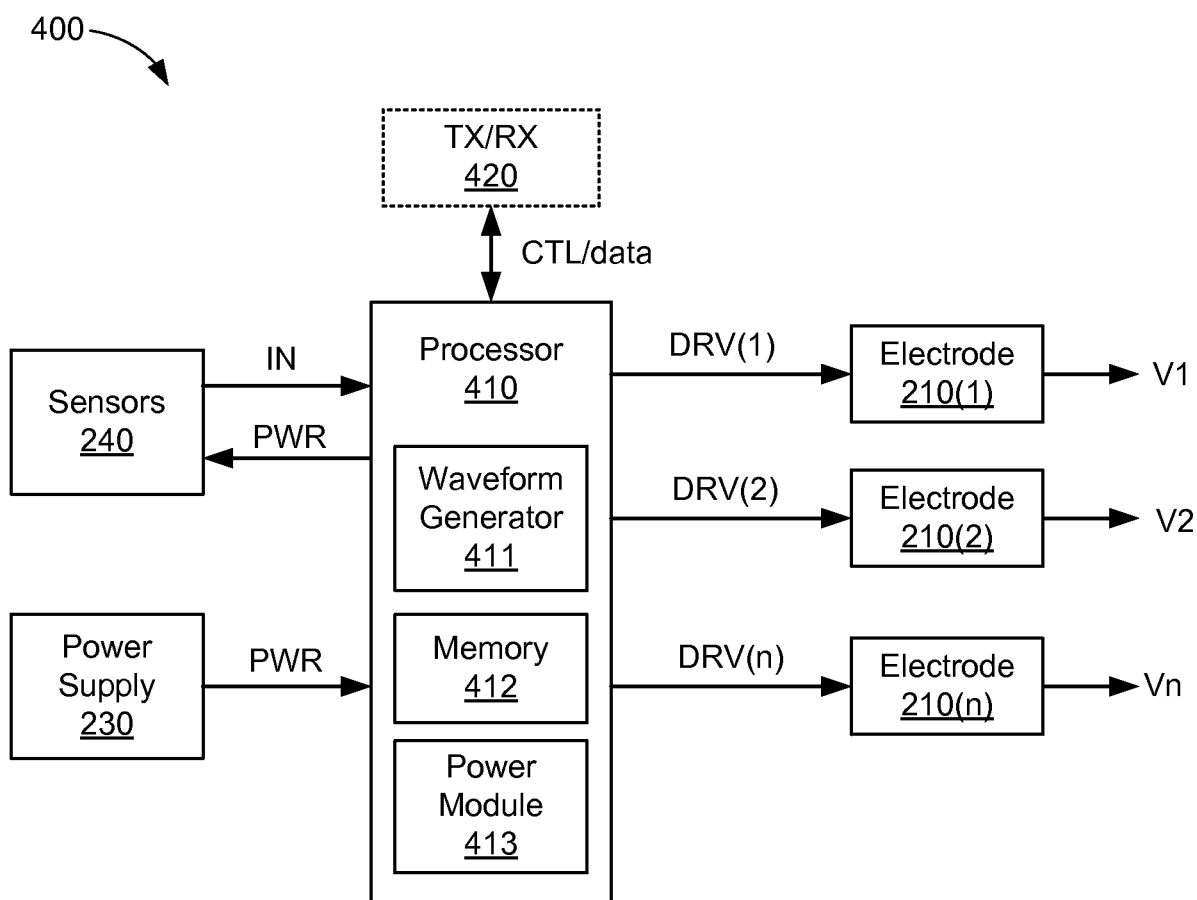

FIG. 4

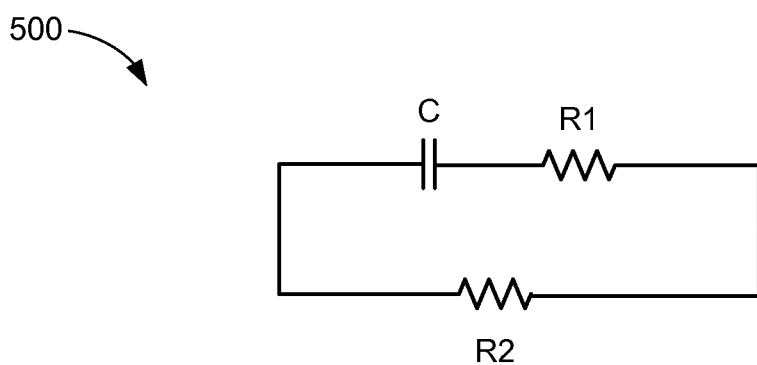

FIG. 5

600 →

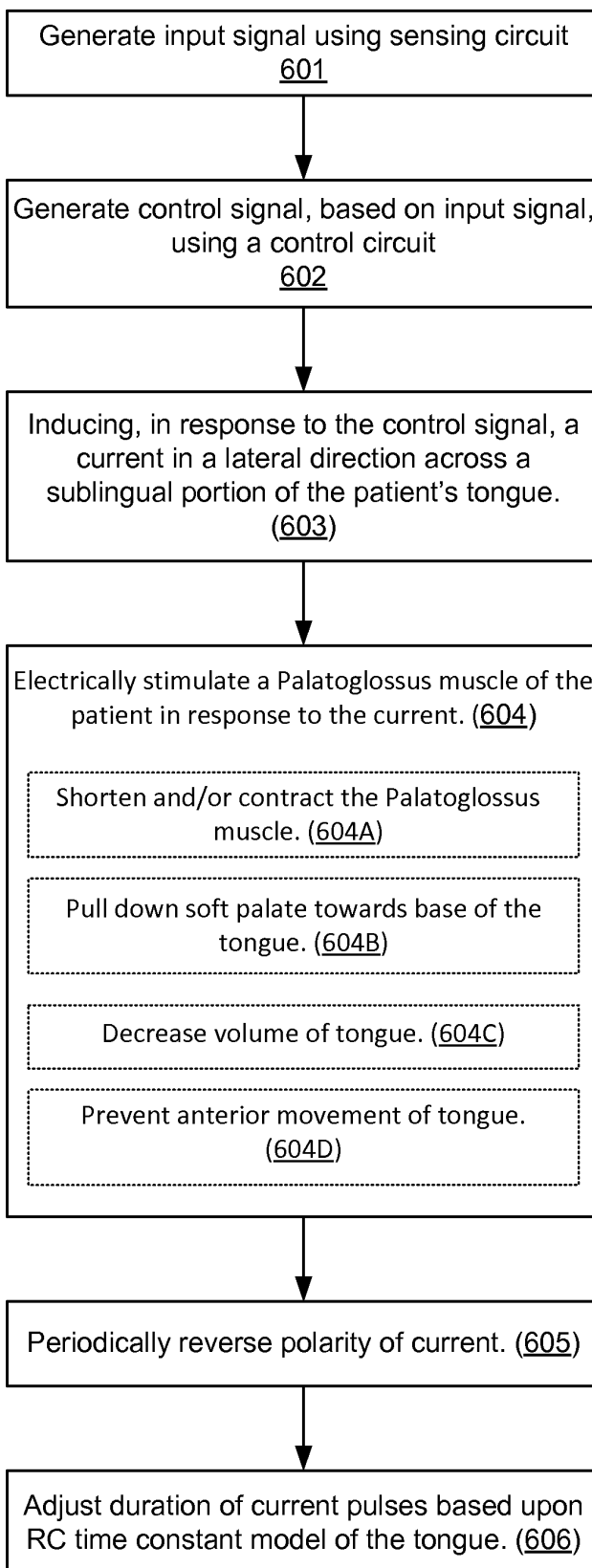

FIG. 6

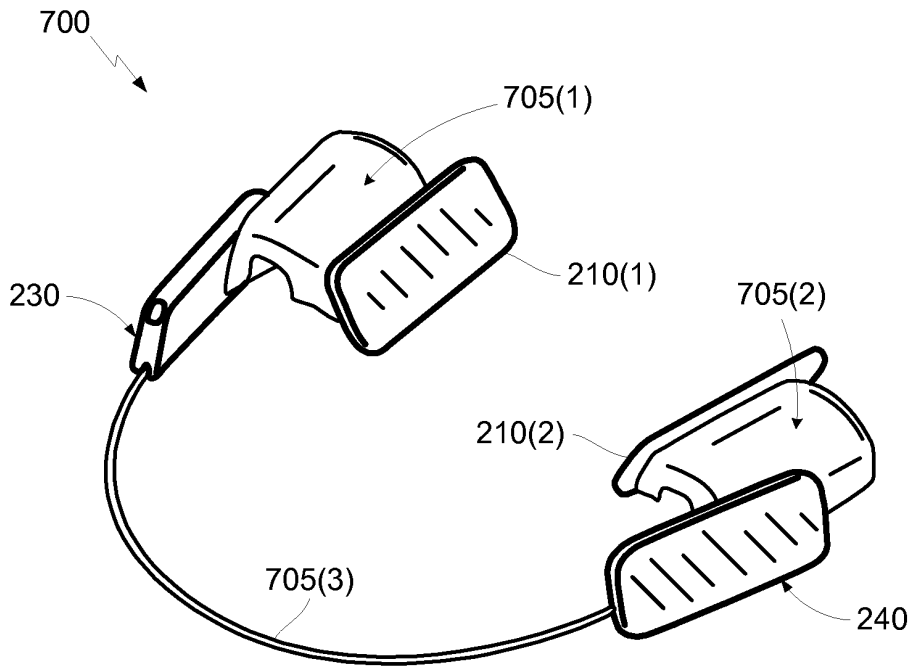

FIG. 7A

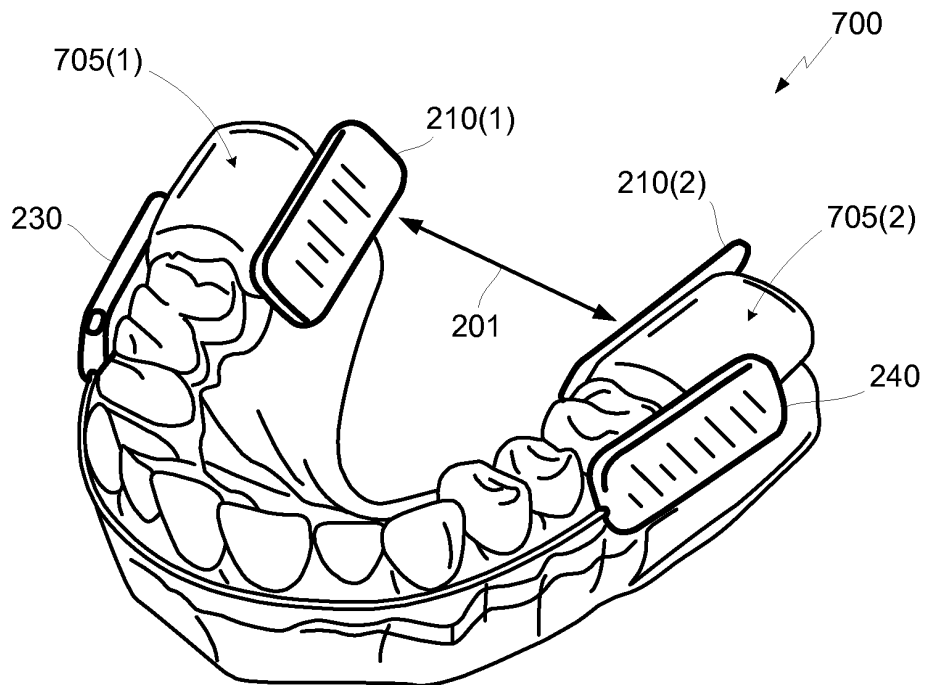

FIG. 7B

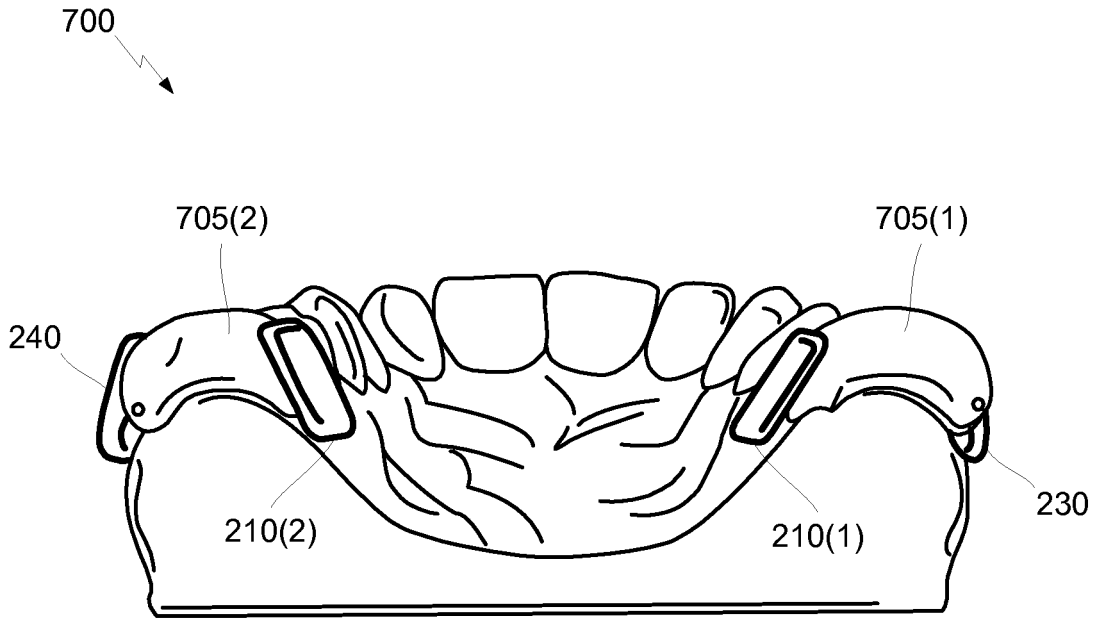

FIG. 7C

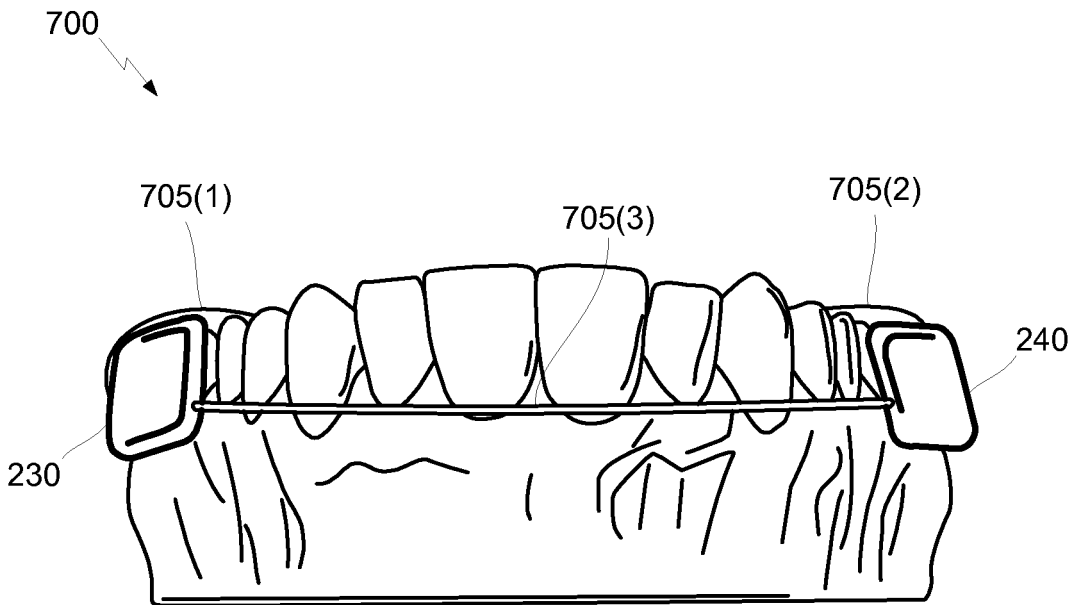

FIG. 7D

REFERENCES CITED IN THE DESCRIPTION

This list of references cited by the applicant is for the reader's convenience only. It does not form part of the European patent document. Even though great care has been taken in compiling the references, errors or omissions cannot be excluded and the EPO disclaims all liability in this regard.

Patent documents cited in the description

- US 4830008 A, Meer [0005]
- US 7711438 B, Lattner [0005]
- US 8359108 B, McCreery [0005] [0020]
- EP 1128868 A [0007]
- US 5190053 A [0020]
- US 6212435 B [0020]

专利名称(译)	治疗睡眠呼吸暂停的装置		
公开(公告)号	EP3092033B1	公开(公告)日	2019-04-24
申请号	EP2015734842	申请日	2015-01-06
[标]申请(专利权)人(译)	因维克塔医药公司		
申请(专利权)人(译)	该医疗公司		
当前申请(专利权)人(译)	INVICTA MEDICAL , INC.		
[标]发明人	KENT STEVEN THOMAS HARTER LAURENCE WYLIE KENT HAROLD BYRON PULDON KARENA YADIRA		
发明人	KENT, STEVEN THOMAS HARTER, LAURENCE WYLIE KENT, HAROLD BYRON PULDON, KARENA YADIRA		
IPC分类号	A61N1/36 A61B5/0488 A61B5/08 A61F5/56 A61B5/00 A61N1/05		
CPC分类号	A61B5/0488 A61B5/0826 A61B5/4818 A61F5/56 A61F5/566 A61N1/0548 A61N1/3601 A61N1/36078 A61N1/0452 A61N1/3603		
优先权	14/149689 2014-01-07 US		
其他公开文献	EP3092033A4 EP3092033A1		
外部链接	Espacenet		

摘要(译)

公开了一种口腔器具，其以防止睡眠期间舌头和/或软腭塌陷的方式向患者的舌头提供电刺激。更具体地，器具可以以缩短患者的腭舌肌的方式在舌头的横向方向上引起可逆电流或电流，这反过来将患者的软腭向下拉向舌根和/或减小体积。舌头

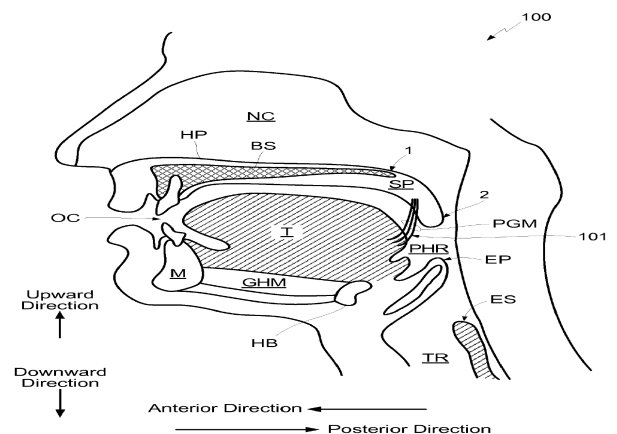

FIG. 1A