



(11) **EP 1 443 855 B1**

(12) **EUROPEAN PATENT SPECIFICATION**

(45) Date of publication and mention of the grant of the patent:
26.03.2008 Bulletin 2008/13

(51) Int Cl.:
A61B 5/00 (2006.01) **A61B 5/22** (2006.01)
A61N 5/06 (2006.01) **G02B 26/08** (2006.01)

(21) Application number: **02789052.4**

(86) International application number:
PCT/SE2002/002050

(22) Date of filing: **11.11.2002**

(87) International publication number:
WO 2003/041575 (22.05.2003 Gazette 2003/21)

(54) **THERAPY AND DIAGNOSIS SYSTEM WITH DISTRIBUTOR FOR DISTRIBUTION OF RADIATION**
THERAPIE- UND DIAGNOSESYSTEM MIT VERTEILER ZUM VERTEILEN VON STRAHLUNG
SYSTEME DE THERAPIE ET DE DIAGNOSTIC A L'AIDE D'UN DISTRIBUTEUR DE RAYONNEMENTS

(84) Designated Contracting States:
AT BE BG CH CY CZ DE DK EE ES FI FR GB GR IE IT LI LU MC NL PT SE SK TR
Designated Extension States:
AL LT LV MK RO SI

• **SVANBERG, Katarina**
S-224 65 Lund (SE)

(30) Priority: **14.11.2001 SE 0103771**

(74) Representative: **Krahbichler, Erik**
Krahbichler Intellectual Property Advisors AB
Kungsgatan 6, 4th floor
252 21 Helsingborg (SE)

(43) Date of publication of application:
11.08.2004 Bulletin 2004/33

(56) References cited:
EP-A- 0 195 375

(73) Proprietor: **Spectracure AB**
223 70 Lund (SE)

• **PATENT ABSTRACTS OF JAPAN** vol. 012, no. 280 (P-739), 2 August 1988 (1988-08-02) & JP 63 060421 A (FUJIKURA LTD), 16 March 1988 (1988-03-16)
• **PATENT ABSTRACTS OF JAPAN** vol. 017, no. 197 (P-1523), 16 April 1993 (1993-04-16) & JP 04 343317 A (FURUKAWA ELECTRIC CO LTD:THE), 30 November 1992 (1992-11-30)

(72) Inventors:
• **SVANBERG, Sune**
S-224 65 Lund (SE)
• **ANDERSSON-ENGELS, Stefan**
S-243 35 Höör (SE)

EP 1 443 855 B1

Note: Within nine months from the publication of the mention of the grant of the European patent, any person may give notice to the European Patent Office of opposition to the European patent granted. Notice of opposition shall be filed in a written reasoned statement. It shall not be deemed to have been filed until the opposition fee has been paid. (Art. 99(1) European Patent Convention).

Description

[0001] The invention relates to a system for photodynamic therapy and/or photothermal therapy and/or diagnosis of a site on and/or in a body, wherein radiation is conducted to the site for reaction with the radiation, wherein the system comprises a distributor of radiation from at least one source of radiation to a reaction site, and from the reaction site to at least one radiation sensor, respectively, and wherein the reaction site preferably is a tumour site.

[0002] Within the field of medical therapy of tumour diseases, a plurality of treatment modalities has been developed for the treatment of malignant tumour diseases, e.g. a tumefaction. Operation, cytostatics treatment, treatment with ionising radiation (gamma or particle radiation), isotope therapy and brachy therapy employing radioactive needles are examples of common treatment modalities. In spite of great progress within therapy, the tumour diseases continue to account for much human suffering, and are responsible for a high percentage of deaths in Western countries. A relatively new treatment modality, photodynamic therapy, commonly abbreviated PDT, provides an interesting complement or alternative in the treatment field. A tumour-seeking agent, normally referred to as a sensitiser, is administered to the body intravenously, orally or topically. It accumulates in malignant tumours to a higher extent than in the surrounding healthy tissue. The tumour area is then irradiated with non-thermal red light, normally from a laser, leading to excitation of the sensitiser to a more energetic state. Through energy transfer from the activated sensitiser to the oxygen molecules of the tissue, the oxygen is transferred from its normal triplet state to the excited singlet state. Singlet oxygen is known to be particularly toxic to tissue; cells are eradicated and the tissue goes in necrosis. Because of the localisation of the sensitiser to tumour cells a unique selectivity is obtained, where surrounding healthy tissue is spared. The initial clinical experience, using in particular haematoporphyrin derivative (HPD) and delta amino levulinic acid (ALA) are good.

[0003] Sensitisers also exhibit a further useful property; to yield a characteristic red fluorescence signal when the substance is excited with violet or ultraviolet radiation. This signal clearly appears in contrast to the autofluorescence of the tissue and can be used to localise tumours and for quantifying the size of the uptake of the sensitiser in the tissue.

[0004] The limited penetration in the tissue of the activating red radiation is a big drawback of PDT. The result is that only tumours up to about 5 mm thickness can be treated by surface irradiation. In order to treat thicker and deep-lying tumours, interstitial PDT (IPDT) can be utilised. Here, light-conducting optical fibres are brought into the tumour using, e.g. a syringe needle, in the lumen of which a fibre has been placed.

[0005] In order to achieve an efficient treatment, several fibres have been used to ascertain that all tumour

cells are subjected to a sufficient dose of light so that the toxic singlet state is obtained. It has been shown to be achievable to perform dose calculations of the absorptive and scattering properties of the tissue. E.g., in the Swedish patent SE 503 408 an IPDT system is described, where six fibres are used for treatment as well as for measurement of the light flux which reaches a given fibre in the penetration through the tissue from the other fibres. In this way an improved calculation of the correct light dose can be achieved for all parts of the tumour.

[0006] In the equipment described in SE 503 408 the light from a single laser is divided up in six different parts using a beamsplitter system comprising a large number of components. The light is then focused into each of the six individual treatment fibres. One fibre is used as a transmitter while the other fibres are used as receivers of radiation penetrating the tissue. For light measurement light detectors are swung into the beam path which thus is blocked, and the weak light, which originates from the fibres that collected the light which is administered to the tissue, is measured.

[0007] However, such open beam paths result in a strongly lossy beamsplitting and the resulting losses of light drastically impair the light distribution as well as the light measurement. Furthermore, such a system must often be adjusted optically, which is also an important consideration in connection with clinical treatments.

[0008] EP 0195375 discloses a catheter for laser angioplasty. A laser catheter is disclosed wherein optical fibers carrying laser light are mounted in a catheter for insertion into an artery to provide controlled delivery of a laser beam for percutaneous intravascular laser treatment of atherosclerotic disease. Multiple optical fibers in the catheter allow the selection of tissue that is to be removed. A computer controlled system automatically aligns fibers with the laser and controls exposure time. However, the system does not provide interstitial interactive treatment of tumours.

[0009] JP 04343317 discloses a switch for optical elements adapted for use in lighting devices or systems thereof, which switch may be operated by rotating two ferrules in respect of each other. To ensure correct positioning the device according to JP 04343317 needs positioning pins since this device is in need of very exact positioning of the fibers to be connected. This way of operating such a switch demands rotational as well as translational movement. Switching is thus cumbersome and slow.

[0010] The purpose of the invention is to eliminate the drawbacks mentioned above, which can be achieved by assigning to the system characteristics according to claim 1, wherein a very practical and efficient implementation of interactive IPDT is achieved in that different optical measurements for diagnostics and dosimetry can be performed in an integrated and simple way. An important application of the invention is interactive, interstitial photodynamic therapy, and/or interactive photothermal tumour therapy.

[0011] In order to more closely explain the invention a number of embodiments of the invention will be described in the following with reference to the figures, wherein

FIG 1 is a schematic perspective view of a first embodiment of the system according to the invention, wherein light conductors arranged in said invention are interstitially inserted in a tumour,

FIG 2 is a view similar to FIG 1, where the discs of the distributor are brought apart,

FIG 3 is a planar view from above of the turnable distributor disc with holes arranged in said disc,

FIG 4 is a fragmentary cross section view of the turnable disc of said distributor, wherein a spring-loaded ball is provided,

FIG 5 is a schematic perspective view illustrating the use of the system according to the invention with the distributor in the mode of tumour diagnostics,

FIG 6 is a view similar to FIG 5 and FIG 2, where two distributors are arranged on the same single axis, and

FIG 7 is a schematic perspective view illustrating the use of the system according to the invention, with the distributor in the mode of photodynamic treatment of a tumour.

[0012] A preferred embodiment of the distributor of the system according to the invention is now described with reference to FIG 1-4. The distributor 1 comprises two flat and in proximity lying discs made of, e.g. 1 cm thick steel. The discs are hereby arranged on an axis 2, wherein one of the discs is a fixed disc 3 and the other one is a turnable disc 4. The discs 3 and 4 are abutting against each other in FIG 1 and separated from each other in FIG 2.

[0013] Evenly distributed holes 5 lying on a circle are arranged in both discs (FIG 3) for fixation of radiation conductors 6, 7. Preferably the diameter of the holes is 0.3 - 0.7 mm. In order to attain a high precision, allowing the light conductors to be arranged exactly face to face, the holes of the two discs can be drilled together, maybe with a centring tube. Then the common axis 2 is utilised. It is thus possible to achieve a very high precision when making the series of holes.

[0014] By employing discs drilled together, radiation conductors can be fixed in said discs, wherein an extra, thinner disc then can be turned slightly, preferably spring-loaded, so that all light conductors are simultaneously pinched in their positions without the need for any glue or other fixation means. Alternatively, the diameter of the holes is made larger than the diameter of the light conductors, wherein the holes can be dressed with an appropriate piece of tubing, or the ends of the light conductors can be supplied with a fitted hose. Alternatively, the ends of the light conductors can be flared or flanged into the holes.

[0015] Preferably the light conductors are optical fibres, wherein different types of hoses or flexible tubes containing a light-conducting material are included. The

light conductors should have such a length and be arranged in such a way that the turnable disc 4 can be turned without problems a full turn (360 degrees). The direction of movement can be reversed to avoid the light conductors forming a spiral.

[0016] According to the invention a plurality of first light conductors 6 in a system are arranged in the fixed disc 3 for conduction of radiation to and from a reaction site 8. By a reaction site we in the present context mean a site where photodynamically active compounds will react in a tumour when subject to therapy. E.g., by being forwarded through the lumen of injection needles which are placed in the tumour, these radiation conductors 6 are then fixed in the reaction site 8. Then the radiation conductors are moved forward to arrive outside the distal end of the needle. The same light conductor 6 is used all the time for integrated diagnostics and dosimetry, to avoid that the patient be subjected to multiple pricks.

[0017] The holes 6 in the fixed disc 3 as well as in the turnable disc 4 are arranged on a circular line, wherein the circle radius on one disc equals the circle radius on the other disc. The holes on one disc are equally distributed along the circle line with an angular separation $v_1 = (360/n_1)$ degrees, where n_1 equals the number of holes, and the holes of the other disc are equally distributed along the circle line with an angular separation v_2 equaling $(360/n_2)$ degrees. The first ends of the first radiation conductors 6 are fixed in the holes of the fixed disc 3, and first ends of the second radiation conductors 7 are fixed in the holes of the turnable disc 4. In order to make the holes, and thereby the radiation conductors in both discs connectable to each other in different constellations by turning of the turnable disc 4, n_2 is selected to be a multiple of n_1 , in such a way that n_2 is obtained as an integer larger or equal to 1. Suitably the number of holes in the fixed disc is chosen from two to more than six.

[0018] Preferably six holes are arranged in the fixed disc 3 and twelve holes are arranged in the turnable disc 4. With six first radiation conductors 6 the angular separation will accordingly become 60 degrees in the fixed disc 3 and with twelve holes arranged in the turnable disc 4 the angular separation will become 30 degrees for the second radiation conductors 7.

[0019] In order to facilitate the comprehension of the invention the following description of a preferred embodiment of the distributor of the system according to the invention relates to six first radiation conductors 6 arranged in the fixed disc 3 for conduction of radiation to and from the reaction site 8.

[0020] Thus, the turnable disc 4, as well as the fixed disc 3, have six holes 5 for corresponding second radiation conductors 7, and, in addition, six further holes for second radiation conductors 7. All these radiation conductors 7 can release radiation to the reaction site 8 and receive radiation from said site. Thus, several spectra can be recorded and read out simultaneously.

[0021] By turning the turnable disc 4 the first and the second radiation conductors become connectable to

each other in different constellations. An exact positioning of the opposing radiation conductors in the distributor 1 is facilitated by arranging means for stopping the turnable disc 4 in pre-determined angular positions. E.g., grooves 10 can be arranged in the axis 2 for catching a spring-loaded ball 11 arranged in the turnable disc 4 (FIG 4).

[0022] In order to allow a fast and efficient switching between a diagnostic mode and a therapeutic mode, every second of the second light conductors of the distributor 1 according to the invention, are divided into a first and into a second series. Both series of holes are arranged on the same circle, but displaced by 30 degrees with regard to each other. A specific light conductor 7a' in the first series of every other second light conductor is arranged for emitting radiation from at least one radiation source 9a. The other, non specific radiation conductors 7a in the first series of second radiation conductors are arranged for conduction of radiation to at least one radiation sensor 12. The second series of every other second radiation conductor 7b is for therapeutical purposes arranged to emit radiation to the reaction site 8 from at least one radiation source 9b.

[0023] In the preferred embodiment of the invention, the radiation conductors are optical fibres, which in the distributor 1 shown in FIG 1 and 2 are connected to the fixed disc 3 as well as the turnable disc 4. Out of the fibres, which are connected to the turnable disc 4, six fibres can be used for diagnostic purposes and six can be used of therapeutical purposes. However, in the diagnostic mode, from one to more than three modalities can be employed.

[0024] With reference to FIG 5-7 only the presently described radiation conductors which are coupled to a turnable disc are for clarifying purposes shown; the other radiation conductors are not shown although they are coupled to said disc.

[0025] By turning the turnable disc 5 by 30 degrees the fibres 6 which are optically coupled to the tissue of the patient can be employed for therapy as well as diagnostics and measurements. One out of every second radiation conductor 7 is in the diagnostic mode connected to different radiation sources for diagnostics, while the other five radiation conductors receive signals, which are related to the interaction of these radiation sources with the tissue.

[0026] Since intensity as well as spectral resolution is of interest, the distal ends of these five radiation conductors are arranged in a slit-like arrangement so that they overlap the entrance slit and/or constitute the entrance slit of the radiation sensor 12, which is a compact spectrometer and is supplied with a two-dimensional detector array. The recording range of the spectrometer is preferably within the range 400 to 900 nm. Each of the radiation conductors 7a can of course be connected to an individual radiation detector 12 in the form of a spectrometer or another type of detector, e.g. a compact integrated spectrometer.

[0027] With reference to FIG 5 the specific radiation conductor 7a' is connected to an arrangement similar to the distributor 1, which comprises a second fixed disc 13 and a second turnable disc 14 which are arranged on a common axis 15. All fixed and turnable discs can also be arranged on one single axis as is shown in FIG 6. A more compact and robust construction is obtained in this way.

[0028] More specifically the radiation conductor 7a' is arranged in a single hole on the second fixed disc 13. Further light conductors 17 are arranged on a circle in said second turnable disc 14; in this case three conductors which are connected to different radiation sources 9a, and which each are connectable to the radiation conductor 7a' and further on to the different first radiation conductors 6.

[0029] Preferably the radiation source 9a is a laser of the same wavelength as the one utilised for the laser irradiation for photodynamic tumour therapy, but of substantially lower output power. Suitable filters can be arranged on the second turnable disc 14, to be turned into the light path of the radiation sensor 12 in order to secure that the correct dynamic range is utilised for all measurement tasks.

[0030] Certain of the radiation sources 9a are utilised in order to study how radiation (light) of the corresponding wavelength is penetrating through the tissue of the tumour. When light from a radiation source 9a is transmitted through the particular radiation conductor 7a' via the discs 14, 13, 4, 3 into the tissue, one of the first radiation conductors 6, which is the one opposing the radiation conductor 6' in the distributor 1, will function as a transmitter in the tumour, and the other five radiation conductors 6 in the tumour will act as receivers and collect the diffuse flux of light reaching them. The light collected is again conducted via the discs 3, 4, 13, 14 to the radiation sensor 12 and five different light intensities can be recorded on the detector array.

[0031] When the turnable disc 4 is turned by 60 degrees, the next radiation conductor 6 to the patient will get the role as transmitter, and the five others become the receivers for a new light distribution. After four further turns of the turnable disc 4, each by 60 degrees to the following radiation conductor 6 in the patient, light flux data for all remaining combinations of transmitters/receivers have been recorded. Thus, in total $6 \times 5 = 30$ measurement values are obtained and can be used as input data for a tomographic modelling of the optical dose build up in the different parts of the tumour during the course of the treatment.

[0032] As an alternative to a specific wavelength, radiation from a white light source can be coupled into the particular light conductor 7a'. On passage through the tissue to the receiving light conductor 6 in the patient, the well-defined spectral distribution of the radiation source 9a will be modified by the tissue absorption. Then, oxygenated blood yields a different signature than non oxygenated blood, allowing a tomographic determination of the oxygen distribution utilising the thirty different spectral

distributions which are read out, five spectra at a time in the six possible different constellations on rotation of the turnable disc 4 during a diagnostic investigation. Such a determination of the oxygenation in the tumour is important, since the PDT process requires access to oxygen in the tissue.

[0033] Finally, a light source for blue/violet or ultraviolet light, e.g. a laser, can be coupled to the particular radiation conductor 7a'. Then fluorescence is induced in the tissue, and a sensitiser administered to the tissue displays a characteristic red fluorescence distribution in the red/near-infrared spectral region. The strength of the corresponding signal allows a quantification of the concentration of the sensitiser in the tissue.

[0034] Since the short wavelength light has a very low penetration into the tissue, the induced fluorescence must be measured locally at the tip of the radiation conductor. For this task there is in this case for the corresponding radiation source 9a at the distal end of the particular radiation conductor 7a' a beamsplitter 18, connected via the radiation conductor 18 and which is preferably dichroitic, transmitting the exciting light but reflecting the red-shifted fluorescence light. This reflected light is focused into the distal end of a conveying radiation conductor 19, the other end of which is connected to the radiation sensor 12, which records the fluorescence light distribution. A suitable self-contained fluorosensor is described in Rev. Sci. Instr. 71, 3004 (2000).

[0035] By rotating the turnable disc 4, the fluorescence which is proportional to the concentration of the sensitiser, can be measured sequentially at the tips of the six radiation conductors. Since the sensitiser is bleached by the strong red treatment light, being particularly strong just around the tip of the radiation conductor 6', it is essential to make this measurement before the start of the treatment.

[0036] If the tips of the radiation conductors 6 in addition are treated with a material, the fluorescence properties of which are temperature dependent, sharp fluorescence lines are obtained upon excitation, and the intensity of the lines and their relative strength depend on the temperature of the tip of the radiation conductor 6' being employed for treatment. Examples of such materials are salts of the transition metals or the rare earth metals. Thus also the temperature can be measured at the six positions of the six radiation conductors, one at a time. The measured temperatures can be utilised to find out if blood coagulation with an associated light attenuation has occurred at the tip of the radiation conductor 6 and for studies regarding the utilisation of possible synergy effects between PDT and thermal interaction. Since the lines obtained are sharp, they can be lifted off the more broad-banded fluorescence distribution from the tissue.

[0037] The concentration of the sensitiser can for certain substances be measured in an alternative way. Then the red light used for the light propagation studies is used to induce near-infrared fluorescence. This fluorescence penetrates through the tissue to the tips of the receiving

radiation conductors 6, and are displayed simultaneously as spectra obtained in the radiation sensor 12. A tomographic calculation of the concentration distribution can be performed based on in total thirty measurement values.

[0038] After diagnostic measurements and calculations have been performed, the fibres 6 optically coupled to the tissue of the patients can be utilised for therapy by rotation of the turnable disc 4 by 30 degrees. Referring to FIG 7, the second series of every other second radiation conductor 7b is utilised, now connected to the opposing radiation conductors 6 via the distributor 1. Each or the six radiation conductors 7b is connected to an individual second radiation source 9b, which preferably is a laser source with a wavelength which is adapted to the absorption band of the sensitiser. At the photodynamic tumour treatment a dye laser or a diode laser is preferably used, with a wavelength which is selected with regard to the sensitiser employed. For Photofrin® the wavelength is 630 nm, for δ amino levulinic acid (ALA) it is 635 and for phthalocyanines it is around 670 nm. The individual lasers are regulated during the treatment to a desirable individual output power. If desired, they may have built-in monitoring detectors.

[0039] The therapeutical treatment can be interrupted and new diagnostic data can be processed in an interactive method till an optimal treatment has been reached. This method can include synergy between PDT and hyperthermia, where an increased temperature is reached at increased fluxes of laser radiation. The whole process is controlled using a computer, which does not only perform all the calculations but also is utilised for regulation.

Claims

1. A system for interactive interstitial photodynamic tumour therapy and/or photothermal tumour therapy and tumour diagnosis, comprising at least one radiation source (9a, 9b), at least one radiation sensor (12) and a radiation conductor (6, 6') which are brought to a tumour site (8), wherein the radiation conductor is in use employed as a transmitter and/or a receiver for conduction of radiation to and/or from the tumour site (8) for diagnosis and therapy of a tumour at the tumour site (8), said system comprising a distributor (1) adapted to distribute radiation from at least one radiation source (9a, 9b) to the tumour site (8), and from the tumour site (8) to at least one radiation sensor (12), wherein the distributor (1) comprises a plurality of first radiation conductors (6, 6') arranged for conducting radiation to and from the tumour site (8), a plurality of second radiation conductors (7, 7a', 7a', 7b) arranged for delivering radiation from the radiation source (9a, 9b) and/or conduction of radiation

- to the radiation sensor (12),
two flat discs (3,4) abutting against each other,
wherein a first of said discs is fixed (3) and the second
of said discs is turnable (4) relatively to the other disc,
each disc has holes (5) arranged on a circular line,
wherein the circle radius on one disc equals the circle
radius on the other disc and where the holes in one
disc are equally distributed on the circle line with an
angular separation of $v_1=(360/n_1)$ degrees, n_1 being
the number of holes, and the holes in the other disc
are equally distributed on the circle line with an angular
separation of $v_2=(360/n_2)$ degrees, wherein n_2
 $= m \times n_1$, and wherein m is a multiple, which yields
 n_2 as an integer ≥ 1 , and
wherein the first ends of the first radiation conductors
(6, 6') are fixed in the holes of the fixed disc (3) and
first ends of the other radiation conductors (7, 7a,
7a', 7b) are fixed in the holes of the turnable disc (4),
whereby the first and the second radiation conductors
by rotation of the turnable disc are connectable
to each other in different constellations related to different
modes of tumour diagnostics and therapy of the system.
2. A system according to claim 1, **characterised by** n_1
being the number of holes in the fixed disc (3) of the
distributor (1), $n_1 = 6$ and $m = 2$, yielding $n_2 = 12$
holes in the turnable disc (4) of the distributor (1).
 3. A system according to claim 1 or 2, **characterised
by** every other second radiation conductor (7) being
part of a first series of second radiation conductors
and that a radiation conductor (7a') in said first series
of second radiation conductors being arranged for
emitting radiation from the radiation source (9a) and
the other radiation conductors (7a) in said first series
of second radiation conductors being arranged for
conduction of radiation to the radiation sensor (12).
 4. A system according to claim 3, **characterised by**
the radiation source (9a) being a light source for
white, red, blue/violet or ultraviolet light.
 5. A system according to claim 4, **characterised by**
the light source comprising a beamsplitter (18).
 6. A system according to claim 5, **characterised by** a
transferring radiation conductor (19) being arranged
between the dichroic beamsplitter (18) and the radi-
ation sensor (12).
 7. A system according to claim 4, **characterised by**
the first radiation conductors (6, 6') second ends be-
ing treated by a material with temperature sensitive
fluorescence emission.
 8. A system according to any of the claims 1-7, **char-
acterised by** the radiation sensor (12) being a spec-
- trometer with a two-dimensional detector array and
the other ends of said other radiation conductors (7a)
of said first series of second radiation conductors
being arranged in the entrance slit of the spectrom-
eter.
9. A system according to claim 1 or 2, **characterised
by** every second other radiation conductor (7) being
part of a second series of second radiation conduc-
tors arranged for emission of radiation from the ra-
diation source (9b).
 10. A system according to any of the claims 1-9, **char-
acterised by** the radiation source (9a, 9b) being a
light source for coherent light of a single fixed wave-
length.
 11. A system according to claim 1, **characterised by**
the distributor including means (10,11) arranged for
locking the turnable disc (4) into pre-determined an-
gular positions.
 12. A system according to claims 1-11, **characterised
by** the radiation conductors (6, 6', 7, 7b) being optical
fibres.
 13. A system according to claims 4-6, **characterised by**
fluorescence being recorded through the same ra-
diation conductor (6') as the one transmitting radi-
ation to the tumour site (8),
 14. A system according to claim 7, **characterised in
that** for interactive photodynamic therapy one or
several of the radiation conductors (6, 6') which are
treated with the material with a temperature sensitive
fluorescence emission are measuring the tempera-
ture at the tumour site (8),
that the radiation which is sent to the tumour site (8)
heats the tumour site (8),
that the intensity of the radiation is controlled by the
measured temperature in order to regulate the tem-
perature of the tumour site (8) at the individual radi-
ation conductors (6, 6').

Patentansprüche

1. System zur interaktiven interstitiellen photodynami-
schen Tumorthherapie und/oder photothermischen
Tumorthherapie und Tumordiagnostik, bestehend
aus mindestens einer Strahlungsquelle (9a, 9b),
mindestens einem Strahlungssensor (12) und einem
Strahlungsleiter (6, 6'), die zu einer Tumorstelle (8)
gebracht werden, wobei der Strahlungsleiter als
Sender und/oder Empfänger für das Leiten der
Strahlung zu und/oder von der Tumorstelle (8) zur
Diagnostik und Therapie eines Tumors an der Tu-
morstelle (8) eingesetzt wird, wobei

das besagte System einen Verteiler (1) umfasst, der die Strahlung von mindestens einer Strahlungsquelle (9a, 9b) zu der Tumorstelle (8) und von der Tumorstelle (8) zu mindestens einem Strahlungssensor (12) verteilt, wobei der Verteiler (1) mehrere erste Strahlungsleiter (6, 6') umfasst, die so angeordnet sind, daß sie die Strahlung zu und von der Tumorstelle (8) leiten, sowie mehrere zweite Strahlungsleiter (7, 7a', 7a'', 7b) umfasst, die so angeordnet sind, daß sie die Strahlung von der Strahlungsquelle (9a, 9b) senden und/oder die Strahlung zu dem Strahlungssensor (12) leiten, sowie zwei flache Scheiben (3, 4) aufweist, die aneinander gereiht sind, wobei die erste der besagten Scheiben fest (3) ist und die zweite der besagten Scheiben im Verhältnis zu der anderen Scheibe drehbar (4) ist, und wobei beide Scheiben Löcher (5) haben, die kreisförmig angeordnet sind, wobei der Kreisradius auf einer Scheibe dem Kreisradius auf der anderen Scheibe gleicht und die Löcher in einer Scheibe gleichmäßig auf der Kreislinie verteilt sind, mit einem Winkelabstand von $v_1 = (360/n_1)$ Grad, wobei n_1 die Anzahl der Löcher darstellt, und die Löcher in der anderen Scheibe gleichmäßig auf der Kreislinie verteilt sind, mit einem Winkelabstand von $v_2 = (360/n_2)$ Grad, wobei $n_2 = m \times n_1$, und wobei m ein Vielfaches ist, wodurch n_2 eine Ganzzahl ≥ 1 ergibt, und wobei die ersten Enden der ersten Strahlungsleiter (6, 6') in den Löchern der festen Scheibe (3) befestigt sind und die ersten Enden der anderen Strahlungsleiter (7, 7a, 7a', 7b) in den Löchern der drehbaren Scheibe (4) befestigt sind, wobei die ersten und zweiten Strahlungsleiter durch Rotation der drehbaren Scheibe miteinander in verschiedenen Konstellationen, bezüglich der verschiedenen Arten der Tumordiagnostik und Therapie des Systems, verbunden werden können.

2. Ein System gemäß des Anspruches 1, **dadurch gekennzeichnet, daß** n_1 die Anzahl der Löcher in der festen Scheibe (3) des Verteilers (1) ist und sich mit $n_1 = 6$ und $m = 2$ eine Anzahl von $n_2 = 12$ Löchern in der drehbaren Scheibe (4) des Verteilers (1) ergibt.
3. Ein System gemäß des Anspruches 1 oder 2, **dadurch gekennzeichnet, daß** jeder zweite der zweiten Strahlungsleiter (7) Teil einer ersten Serie zweiter Strahlungsleiter ist und daß ein Strahlungsleiter (7a') der besagten ersten Serie zweiter Strahlungsleiter zur Aussendung von Strahlung von der Strahlungsquelle (9a) ausgebildet ist und die anderen Strahlungsleiter (7a) der besagten ersten Serie zweiter Strahlungsleiter so angeordnet sind, daß die Strahlung zu dem Strahlungssensor (12) geleitet wird.

4. Ein System gemäß des Anspruches 3, **dadurch gekennzeichnet, daß** die Strahlungsquelle (9a) eine Lichtquelle für weißes, rotes, blaues/violettes oder ultraviolettes Licht ist.
5. Ein System gemäß des Anspruches 4, **dadurch gekennzeichnet, daß** die Lichtquelle einen Strahlungsteiler (18) umfasst.
6. Ein System gemäß des Anspruches 5, **dadurch gekennzeichnet, daß** ein übertragender Strahlungsleiter (19) zwischen dem dichroitischen Strahlungsteiler (18) und dem Strahlungssensor (12) angeordnet ist.
7. Ein System gemäß des Anspruches 4, **dadurch gekennzeichnet, daß** die zweiten Enden der ersten Strahlungsleiter (6, 6') mit einem Material mit temperaturempfindlicher Fluoreszenzemission behandelt sind.
8. Ein System gemäß einem der Ansprüche 1-7, **dadurch gekennzeichnet, daß** der Strahlungssensor (12) ein Spektrometer mit einem zweidimensionalen Detektorarray ist und die anderen Enden der besagten anderen Strahlungsleiter (7a) der besagten ersten Serie zweiter Strahlungsleiter in dem Eingangsspalt des Spektrometers angeordnet sind.
9. Ein System gemäß der Ansprüche 1 oder 2, **dadurch gekennzeichnet, daß** jeder zweite der zweiten Strahlungsleiter (7) Teil einer zweiten Serie zweiter Strahlungsleiter ist, und zur Emission von Strahlung der Strahlungsquelle (9b) ausgebildet ist.
10. Ein System gemäß einem der Ansprüche 1-9, **dadurch gekennzeichnet, daß** die Strahlungsquelle (9a, 9b) eine Lichtquelle für kohärentes Licht einer einzigen feststehenden Wellenlänge ist.
11. Ein System gemäß des Anspruches 1, **dadurch gekennzeichnet, daß** der Verteiler ein Element (10, 11) zur Verrastung der drehbaren Scheibe (4) in einer vorbestimmten Winkelposition umfasst.
12. Ein System gemäß der Ansprüche 1-11, **dadurch gekennzeichnet, daß** die Strahlungsleiter (6, 6', 7, 7b) optische Lichtwellenleiter sind.
13. Ein System gemäß der Ansprüche 4-6, **dadurch gekennzeichnet, daß** Fluoreszenz durch den gleichen Strahlungsleiter (6')

erfasst wird, der die Strahlung auch zu der Tumorstelle (8) sendet.

14. Ein System gemäß des Anspruches 7,

dadurch gekennzeichnet, daß

für die interaktive photodynamische Therapie eine oder mehrere Strahlungsleiter (6, 6'), die mit dem Material mit temperaturempfindlicher Fluoreszenzmission behandelt sind, die Temperatur an der Tumorstelle (8) messen,

daß die Strahlung, die zur Tumorstelle (8) gesendet wird, die Tumorstelle (8) erhitzt,

daß die Intensität der Strahlung durch die gemessene Temperatur kontrolliert wird, um die Temperatur der Tumorstelle (8) an den einzelnen Strahlungsleitern (6, 6') zu regulieren.

Revendications

1. Système destiné à la thérapie de tumeur photodynamique interstitielle interactive et/ou thérapie de tumeur photothermique et au diagnostic de tumeur, comprenant au moins une source de rayonnement (9a, 9b), au moins un capteur de rayonnement (12) et un conducteur de rayonnement (6, 6') qui sont amenés sur un site de tumeur (8), dans lequel le conducteur de rayonnement est, en utilisation, employé comme un émetteur et/ou un récepteur pour conduire le rayonnement vers et/ou depuis le site de tumeur (8) pour le diagnostic et la thérapie d'une tumeur au niveau du site de tumeur (8), ledit système comprenant un distributeur (1) adapté pour distribuer un rayonnement depuis au moins une source de rayonnement (9a, 9b) vers le site de tumeur (8), et depuis le site de tumeur (8) vers au moins un capteur de rayonnement (12), dans lequel le distributeur (1) comprend une pluralité de premiers conducteurs de rayonnement (6, 6') agencés pour conduire le rayonnement vers et depuis le site de tumeur (8), une pluralité de seconds conducteurs de rayonnement (7, 7a', 7a', 7b) agencés pour délivrer un rayonnement depuis la source de rayonnement (9a, 9b) et/ou conduire le rayonnement vers le capteur de rayonnement (12), deux disques plats (3, 4) s'appuyant l'un sur l'autre, dans lequel un premier desdits disques est fixe (3) et le second desdits disques peut tourner (4) par rapport à l'autre disque, chaque disque comporte des trous (5) agencés sur une ligne circulaire, dans lequel le rayon du cercle sur un disque est égal au rayon du cercle sur l'autre disque et où les trous dans un disque sont répartis de manière égale sur la ligne circulaire avec une séparation angulaire de $v_1 = (360/n_1)$ degrés, n_1 étant le nombre de trous, et les trous dans l'autre disque sont répartis de manière égale sur la ligne

circulaire avec une séparation angulaire de $v_2 = (360/n_2)$ degrés, où $n_2 = m \times n_1$, et où m est un multiple, qui produit n_2 en tant qu'entier ≥ 1 , et dans lequel les premières extrémités des premiers conducteurs de rayonnement (6, 6') sont fixées dans les trous du disque fixe (3) et les premières extrémités des autres conducteurs de rayonnement (7, 7a, 7a', 7b) sont fixées dans les trous du disque pouvant tourner (4), moyennant quoi les premiers et seconds conducteurs de rayonnement par la rotation du disque pouvant tourner peuvent être raccordés les uns aux autres dans différentes constellations liées à différents modes de diagnostic et thérapie de tumeur du système.

2. Système selon la revendication 1, **caractérisé en ce que** n_1 est le nombre de trous dans le disque fixe (3) du distributeur (1), $n_1 = 6$ et $m = 2$, produisant $n_2 = 12$ trous dans le disque pouvant tourner (4) du distributeur (1).
3. Système selon la revendication 1 ou 2, **caractérisé en ce qu'**un second conducteur de rayonnement (7) sur deux fait partie d'une première série de seconds conducteurs de rayonnement, et **en ce qu'**un conducteur de rayonnement (7a') dans ladite première série de seconds conducteurs de rayonnement est agencé pour émettre un rayonnement depuis la source de rayonnement (9a) et les autres conducteurs de rayonnement (7a) dans ladite première série de seconds conducteurs de rayonnement sont agencés pour conduire le rayonnement vers le capteur de rayonnement (12).
4. Système selon la revendication 3, **caractérisé en ce que** la source de rayonnement (9a) est une source de lumière pour la lumière blanche, rouge, bleue/violette ou ultraviolette.
5. Système selon la revendication 4, **caractérisé en ce que** la source de lumière comprend un séparateur de faisceau (18).
6. Système selon la revendication 5, **caractérisé en ce qu'**un conducteur de rayonnement par transfert (19) est agencé entre le séparateur de faisceau dichroïque (18) et le capteur de rayonnement (12).
7. Système selon la revendication 4, **caractérisé en ce que** les secondes extrémités des premiers conducteurs de rayonnement (6, 6') sont traitées par un matériau avec une émission de fluorescence sensible à la température.
8. Système selon l'une quelconque des revendications 1 à 7, **caractérisé en ce que** le capteur de rayonnement (12) est un spectromètre avec un ensemble détecteur bidimensionnel et les autres extrémités

desdits autres conducteurs de rayonnement (7a) de ladite première série de seconds conducteurs de rayonnement sont agencées dans la fente d'entrée du spectromètre.

5

9. Système selon la revendication 1 ou 2, **caractérisé en ce qu'**un second conducteur de rayonnement (7) sur deux fait partie d'une seconde série de seconds conducteurs de rayonnement agencés pour l'émission de rayonnement depuis la source de rayonnement (9b). 10
10. Système selon l'une quelconque des revendications 1 à 9, **caractérisé en ce que** la source de rayonnement (9a, 9b) est une source de lumière pour la lumière cohérente d'une seule longueur d'onde fixe. 15
11. Système selon la revendication 1, **caractérisé en ce que** le distributeur comprend un moyen (10, 11) agencé pour bloquer le disque pouvant tourner (4) dans des positions angulaires prédéterminées. 20
12. Système selon les revendications 1 à 11, **caractérisé en ce que** les conducteurs de rayonnement (6, 6', 7, 7b) sont des fibres optiques. 25
13. Système selon les revendications 4 à 6, **caractérisé en ce que** la fluorescence est enregistrée par le biais du même conducteur de rayonnement (6') que celui émettant le rayonnement vers le site de tumeur (8). 30
14. Système selon la revendication 7, **caractérisé en ce que**, pour une thérapie photodynamique interactive, un ou plusieurs des conducteurs de rayonnement (6, 6') qui sont traités avec le matériau avec une émission de fluorescence sensible à la température mesurent la température au niveau du site de tumeur (8), 35
en ce que le rayonnement qui est envoyé vers le site de tumeur (8) chauffe le site de tumeur (8), 40
en ce que l'intensité du rayonnement est commandée par la température mesurée afin de réguler la température du site de tumeur (8) au niveau des conducteurs de rayonnement individuels (6, 6'). 45

45

50

55

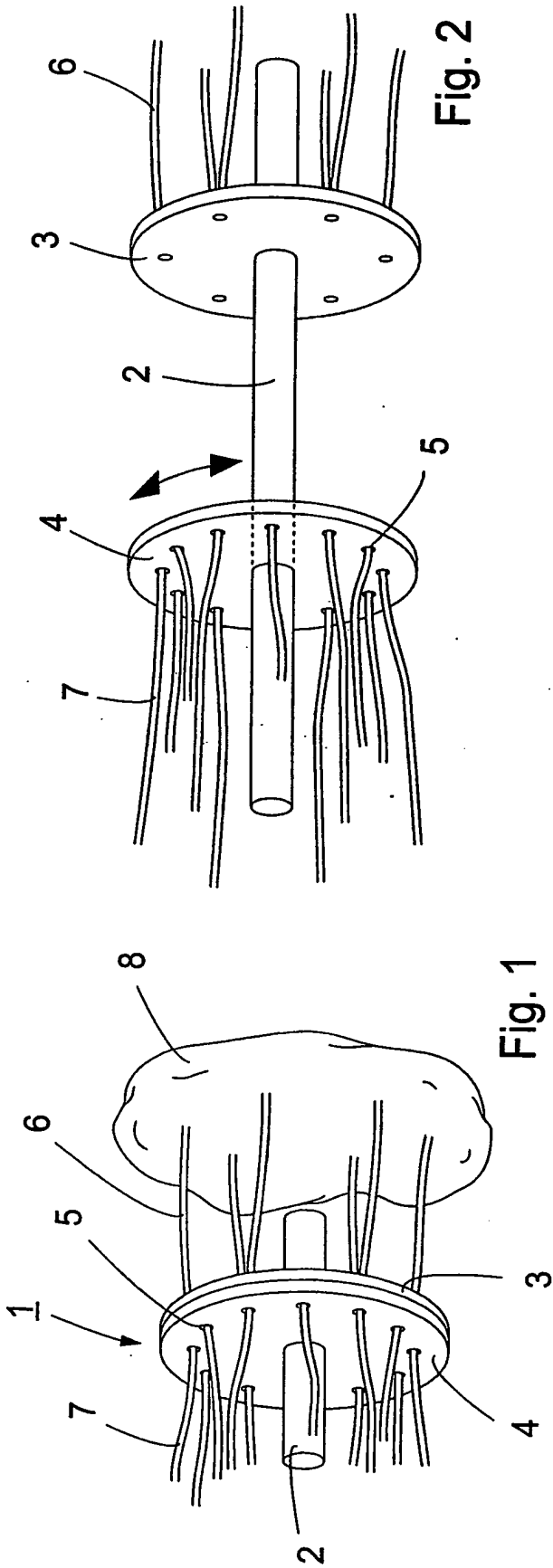

Fig. 2

Fig. 1

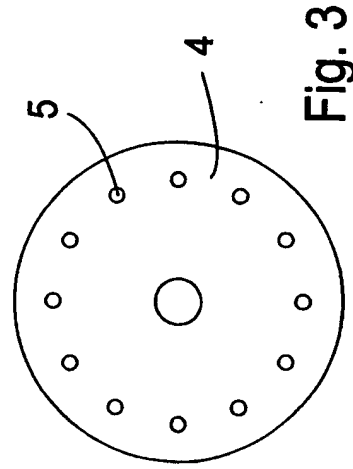

Fig. 3

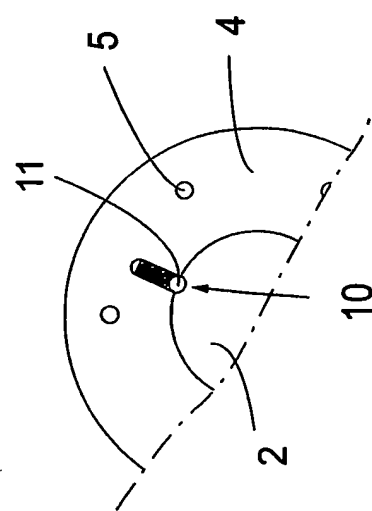
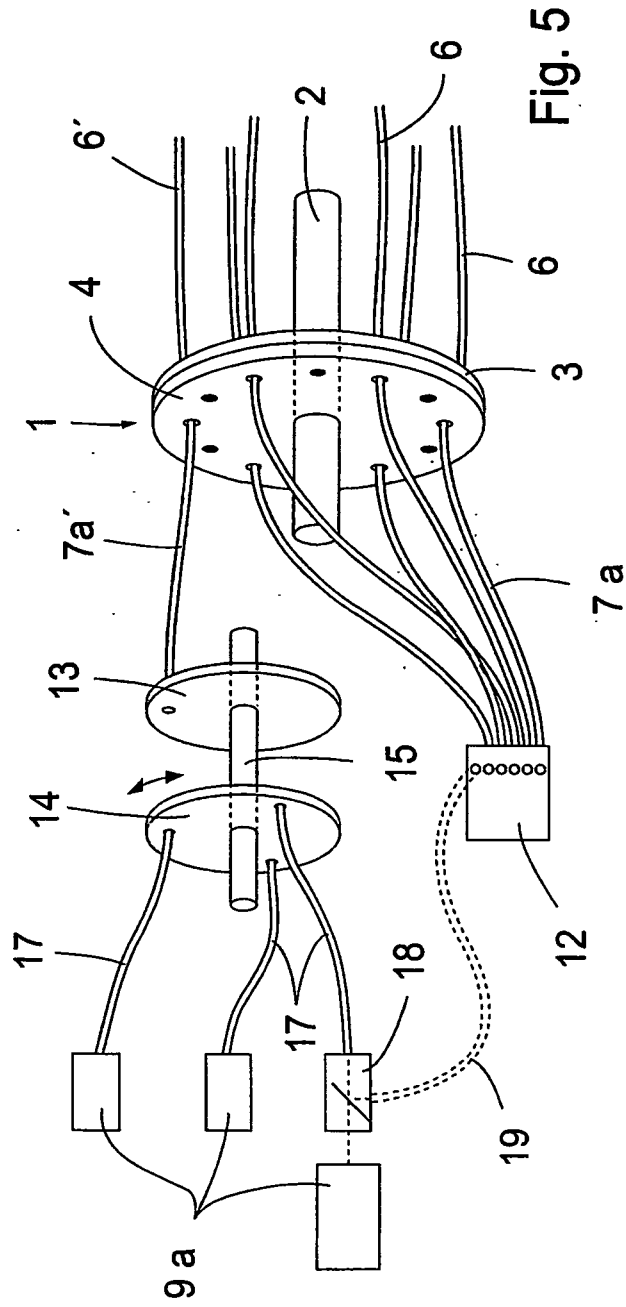
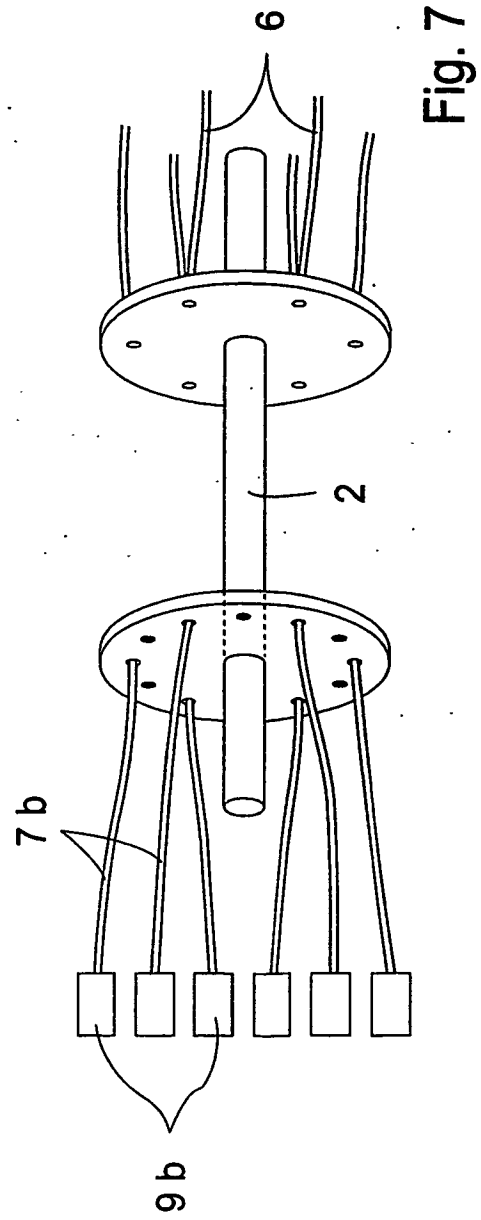
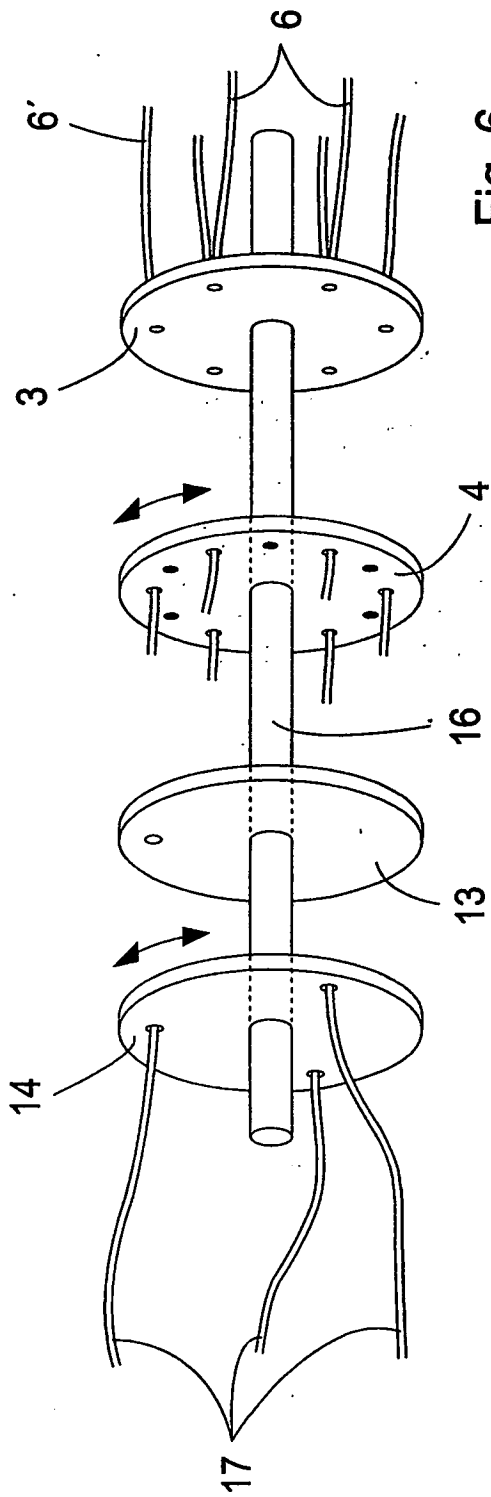

Fig. 4





REFERENCES CITED IN THE DESCRIPTION

This list of references cited by the applicant is for the reader's convenience only. It does not form part of the European patent document. Even though great care has been taken in compiling the references, errors or omissions cannot be excluded and the EPO disclaims all liability in this regard.

Patent documents cited in the description

- SE 503408 [0005] [0006]
- EP 0195375 A [0008]
- JP 04343317 B [0009] [0009]

Non-patent literature cited in the description

- *Rev. Sci. Instr.*, 2000, vol. 71, 3004 [0034]

专利名称(译)	带分配器的治疗和诊断系统用于辐射分布		
公开(公告)号	EP1443855B1	公开(公告)日	2008-03-26
申请号	EP2002789052	申请日	2002-11-11
申请(专利权)人(译)	SPECTRACURE AB		
当前申请(专利权)人(译)	SPECTRACURE AB		
[标]发明人	SVANBERG SUNE ANDERSSON ENGELS STEFAN SVANBERG KATARINA		
发明人	SVANBERG, SUNE ANDERSSON-ENGELS, STEFAN SVANBERG, KATARINA		
IPC分类号	A61B5/00 A61B5/22 A61N5/06 G02B26/08 A61B10/00		
CPC分类号	A61N5/062 A61B5/1455 A61N5/0601 A61N2005/0612 A61N2005/063 G02B6/3504 G02B6/3556 G02B6/4298		
代理机构(译)	KRAHBICHLER, ERIK		
优先权	0103771 2001-11-14 SE		
其他公开文献	EP1443855A1		
外部链接	Espacenet		

摘要(译)

用于交互式，间质光动力学和/或光热肿瘤治疗的系统和方法，所述系统包括分配器1，用于将辐射从至少一个辐射源9a，9b分配到反应部位8，或从反应部位8分配到至少多个第一辐射导体6,6'；布置成用于将辐射传导到反应部位8和从反应部位8传导辐射，并且多个第二辐射导体7,7a，7a'；7b布置成用于从辐射传感器发射辐射。辐射源9a，9b和/或辐射传导到辐射传感器12。分配器包括两个彼此邻接安装的平面盘3,4，一个固定而另一个相对于第一个可转动，每个圆盘具有均匀分开的孔在圆形线上，可转动盘中的孔数是固定盘中孔数的倍数。第一辐射导体6,6'的一端固定在固定盘3的孔中，第二辐射导体7,7a，7a'；7b的一端固定在可转动盘的孔中。

