



(51) International Patent Classification:

A61B 5/107 (2006.01) A61B 5/053 (2006.01)  
A61B 5/00 (2006.01)

(21) International Application Number:

PCT/EP2018/064386

(22) International Filing Date:

31 May 2018 (31.05.2018)

(25) Filing Language:

English

(26) Publication Language:

English

(30) Priority Data:

62/512,992 31 May 2017 (31.05.2017) US

(71) Applicant: **FOUNDRY INNOVATION & RESEARCH 1, LTD.** [IE/IE]; Arthur Cox Building, Earlsfort Centre Earlsfort Terrace, Dublin 2 (IE).

(72) Inventors: **SUTTON, Douglas S.**; Pacifica, California (US). **GIFFORD III, Hanson S.**; Woodside, California (US). **SWEENEY, Fiachra M.**; Dublin (IE). **WILFLEY, Brian**; Sunnyvale, California (US). **MCKENNA, Edward**; Sebastapool, California (US). **ZHOU, Xuance**; Newark, California (US). **CALLAS, Peter**; Castro Valley, California (US). **FAN, Daniel**; Palo Alto, California (US).

(74) Agent: **TOMKINS & CO**; 5 Dartmouth Road, Dublin, 6 (IE).

(81) Designated States (unless otherwise indicated, for every kind of national protection available): AE, AG, AL, AM, AO, AT, AU, AZ, BA, BB, BG, BH, BN, BR, BW, BY, BZ, CA, CH, CL, CN, CO, CR, CU, CZ, DE, DJ, DK, DM, DO, DZ, EC, EE, EG, ES, FI, GB, GD, GE, GH, GM, GT, HN, HR, HU, ID, IL, IN, IR, IS, JO, JP, KE, KG, KH, KN, KP,

KR, KW, KZ, LA, LC, LK, LR, LS, LU, LY, MA, MD, ME, MG, MK, MN, MW, MX, MY, MZ, NA, NG, NI, NO, NZ, OM, PA, PE, PG, PH, PL, PT, QA, RO, RS, RU, RW, SA, SC, SD, SE, SG, SK, SL, SM, ST, SV, SY, TH, TJ, TM, TN, TR, TT, TZ, UA, UG, US, UZ, VC, VN, ZA, ZM, ZW.

(84) Designated States (unless otherwise indicated, for every kind of regional protection available): ARIPO (BW, GH, GM, KE, LR, LS, MW, MZ, NA, RW, SD, SL, ST, SZ, TZ, UG, ZM, ZW), Eurasian (AM, AZ, BY, KG, KZ, RU, TJ, TM), European (AL, AT, BE, BG, CH, CY, CZ, DE, DK, EE, ES, FI, FR, GB, GR, HR, HU, IE, IS, IT, LT, LU, LV, MC, MK, MT, NL, NO, PL, PT, RO, RS, SE, SI, SK, SM, TR), OAPI (BF, BJ, CF, CG, CI, CM, GA, GN, GQ, GW, KM, ML, MR, NE, SN, TD, TG).

Published:

— with international search report (Art. 21(3))

(54) Title: IMPLANTABLE SENSORS FOR VASCULAR MONITORING

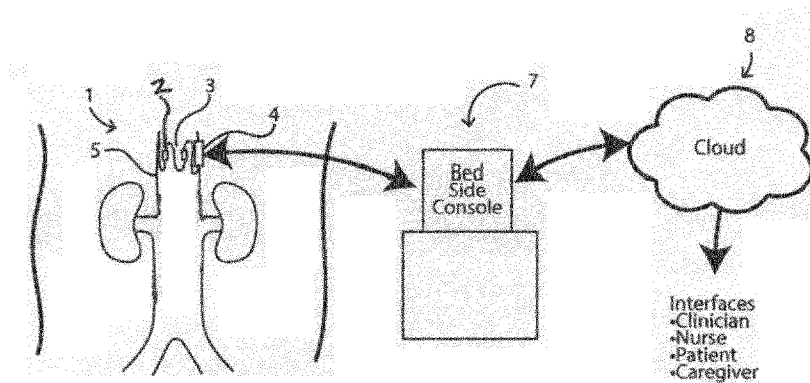

Fig.1

(57) Abstract: An implantable sensor for implantation in a vessel, comprising a plurality of electrodes for placement on, in or adjacent a vessel wall, means for providing a drive signal to the electrodes, means for measuring at least one of impedance and capacitance between at least two of the plurality of electrodes, and means for wirelessly communicating data from the sensor and a blood vessel monitoring system comprising same.



## IMPLANTABLE SENSORS FOR VASCULAR MONITORING

## RELATED APPLICATIONS

5 WO2016/131020 and WO2017/024051 are filed by the present Assignee and are incorporated by reference herein in their entirety.

## FIELD OF THE DISCLOSURE

10 The present disclosure generally relates to the field of medical devices and methods for monitoring patient blood vessels (or “vascular lumen”), such as the inferior vena cava (“IVC”).

## BACKGROUND

Conditions which may be monitored by IVC or other blood vessel monitoring

15 Heart failure is one of the most significant chronic conditions afflicting adult populations. In the United States, 5.7 million Americans have heart failure, with 870,000 new cases annually. As the population ages, this number is growing, as approximately 10% of the population over 80 suffers from heart failure.

20 In patients with chronic heart failure, significant costs are due to hospitalization to manage acutely decompensated heart failure (ADHF). Each re-hospitalization can last up to a week. ADHF is very often a result of some combination of a downturn in the heart’s performance, a downturn in the kidney’s removal of fluid from the bloodstream, and/or excessive intake of fluids and/or salt. This leads to a buildup of fluid in the vascular system, resulting in increased blood volume in the left atrium at higher pressure. This eventually leads to fluid filling the lungs and an inability to breathe. Managing these patients to prevent the need for re-hospitalization is extremely challenging. Non-  
25 invasive approaches to monitoring patients have been tried, such as weighing patients daily to detect fluid weight gain, or having a nurse call them daily to assess their health status, but these approaches have only modest effectiveness.

30 Although measurement of left atrial pressure, typically by measuring pulmonary artery wedge pressure, is commonly considered the most direct way to measure congestion in heart failure, there are other areas where congestion can be detected. When additional blood volume is added to the circulatory system, the IVC is one of the first places for that added volume to have an effect. The diameter of the IVC has demonstrated correlation with central venous pressure and right atrial pressure (as a proxy for left atrial pressure) as it flows directly into the right atrium

(and by extension left atrial pressure through the connection through the pulmonary circulation), and it may correlate with renal function and renal sodium retention, which are also very important prognostic factors of heart failure. Therefore, increasing IVC volume and/or pressure may be a very effective early indicator of worsening heart condition.

5 In addition to heart failure patients, hemodialysis patients have a chronic need for careful volume management. Since their kidneys are not excreting fluid, they are constantly becoming overloaded with fluid. Furthermore, large volumes of fluid are involved in the hemodialysis process, and managing patients so that they do not end up hypovolemic or overloaded with fluid requires careful management.

10 There are other groups of patients who might benefit from such a monitor. For example, patients in septic shock or acute shock due to trauma are subject to hypoperfusion.

#### Current approaches to monitoring the IVC or other blood vessels

15 Prior studies of IVC dimensions have been conducted using external ultrasound imaging. This typically requires a highly trained physician or ultrasound technician to manage the ultrasound machine, ensure an appropriate connection of the transducer to the skin, position the ultrasound transducer in the appropriate location, identify the IVC, and take accurate measurements. This is not something that heart failure patients or their caregivers could typically be trained to do predictably and accurately with existing equipment. Moreover, these systems typically include large, complex, and expensive pieces of equipment which are not suitable for use outside of a specialized medical facility and are therefore not designed for serial measurements for chronic monitoring purposes.

25 Recent studies have indicated that the variation in IVC diameter over the respiratory cycle may be a more sensitive measurement of fluid overload and/or heart failure than simple measurement of average IVC diameter, volume, or pressure. During inspiration, intrathoracic pressure decreases, thereby increasing venous return and causing collapse of the IVC. During expiration, intrathoracic pressure increases, decreasing venous return and causing an increase in the diameter of the IVC.

30 While vessel dimensions may be measurable using external ultrasound, magnetic resonance imaging, computerized axial tomography, or other technologies, these imaging procedures must be administered in a hospital or other specialized facility. Furthermore, such procedures do not

permit continuous monitoring and do not allow for monitoring of the patient at their home or other remote location. As a result, the condition of a heart failure patient can worsen into a critical state before care providers become aware of it, dramatically increasing the mortality risk and cost of treatment for the patient.

- 5 PCT publication numbers WO2016/131020 and WO2017/024051, assigned to the assignee of the present disclosure, describe approaches involving implanted and catheter-based devices for real time monitoring of IVC dimensions for the diagnosis and treatment of heart failure and other conditions.
- 10 The present disclosure is directed towards providing improved apparatus for blood vessel dimension monitoring.

#### SUMMARY OF THE DISCLOSURE

- 15 In accordance with the present invention there is provided an implantable sensor for implantation in a vessel, comprising:

- a plurality of electrodes for placement on, in or adjacent a vessel wall;
- means for providing a drive signal to the electrodes;
- means for measuring at least one of impedance and capacitance between at least two of the plurality of electrodes; and
- 20 means for wirelessly communicating data from the sensor.

The implantable sensor may further comprise means for calculating distance between the electrodes based on the measured impedance or the measured capacitance.

- 25 The implantable sensor may further comprise means for estimating vessel diameter based on measurements of impedance or capacitance between at least two of the plurality of electrodes.

The implantable sensor may further comprise means for determining cross-sectional area of the vessel's lumen based on said impedance or capacitance.

- 30 The implantable sensor may further comprise means for selecting a pair of electrodes from the plurality of electrodes to which drive signals are to be delivered.

The implantable sensor may further comprise means for estimating blood velocity from the calculated distance between the electrodes.

5 The implantable sensor may further comprise means for estimating a pressure gradient from the calculated distance between the electrodes.

The implantable sensor may further comprise at least one reference electrode maintained at a fixed distance from one of the electrodes and means for measuring at least one of impedance or capacitance between said electrode and said reference electrode.

10 The implantable sensor may further comprise means for calibrating measurements between the plurality of electrodes using a measurement of impedance or capacitance between said electrode and said reference electrode.

The implantable sensor may further comprise means for processing the measured electrical parameter to monitor variations in the conductivity of the intervening media and to apply a  
15 correction factor accordingly.

The implantable sensor may further comprise means for wirelessly communicating data from the sensor, the means being configured to wirelessly communicate the measured impedance and/or  
20 capacitance.

The implantable sensor may further comprise a memory for storing the measurements.

The implantable sensor may further comprise processing means for processing the measured  
25 data.

The implantable sensor may further comprise means for wirelessly receiving data from a remote transmitter.

The implantable sensor may further comprise means for biasing the plurality of electrodes  
30 against the vessel wall.

The plurality of electrodes may be anchorable to or within the vessel wall.

The plurality of electrodes may comprise a circumferential array of electrodes.

The plurality of electrodes may comprise a plurality of pairs of electrodes.

5 The implantable sensor may further comprise a support structure with sufficient elasticity to collapse and expand with the vessel without constraining the vessel's natural physiological shape changes, on which the electrodes are mounted. In other words, in use, the electrodes move with the vessel wall. A movement of the vessel wall in a radial direction would impart a corresponding movement of the electrodes in a radial direction.

10 The implantable sensor may further comprise a support structure having an anchored part configured to engage the vessel wall and wherein each electrode is coupled to the support structure by a connecting strut extending from the anchored part of the support structure, the connecting strut being configured to bias the electrode into engagement with the vessel wall. In some embodiments each electrode is coupled to the inside of a connecting strut. This is an example of each electrode being placeable on the vessel wall. In other embodiments each  
15 electrode is coupled to the outside of a connecting strut. This is an example of each electrode being placeable adjacent the vessel wall.

20 The at least one connecting strut may be cantilevered from the anchored part of the support structure.

The support structure may comprise a stent-like flexible, elastic, cylindrical structure comprised of a slotted tube, interconnecting struts, or mesh, and/or having a continuous zig-zag or sinusoidal geometry.

25 The at least one strut may comprise an anchor for engagement directly with a vessel wall.

At least part of the sensor may be configured to endothelialize on a vessel wall. This is an example of each electrode being placeable in the vessel wall.

30 At least one electrode may have an anti-fouling surface to prevent endothelialization on a vessel wall.

The anti-fouling surface may include one or more material selected from carbon nanotubes, conductive polymers, hydrogels, conductive hydrogels, bioactive coatings, and a tissue engineered neural interface.

- 5 The implantable sensor may be configured for untethered retention in a vessel. In other words, there is no catheter attached to the implant after implantation.

The implantable sensor may be configured for retention in a vessel following withdrawal of a deployment catheter.

10

The implantable sensor may further comprise means for executing an algorithm to reduce effects of fouling and/or endothelialisation on electrode surfaces.

- 15 The algorithm may include one or more of the steps of performing impedance-to-distance calibration based on resting dimensions; salinity recalibration with scales impedance measurements with reference change, geometric reconstruction with elliptical assumption, fouling detection and rejection according to electrode geometry, preferably with data from three or more electrodes to reconstruct an ellipse, additional data used to detect and reject fouling.

- 20 The implantable sensor may further comprise means for performing data correction with parallelogram edge and diagonal correction, by averaging opposed parallelogram sides.

The implantable sensor may further comprise means for performing ellipse reconstruction to model a vessel shape, based on chordal lengths such as parallelogram side calculations.

25

The implantable sensor may further comprise means for applying a correction to compensate for change from a round to elliptical cross-sectional shape of the vessel.

- 30 The implantable sensor may further comprise means for comparing a parameter between multiple pairs of electrodes.

The implantable sensor may further comprise means for determining a pair of electrodes which is most closely aligned with a selected axis of the vessel.

The implantable sensor may be adapted to determine vessel collapsibility or deformity over at least one respiratory cycle.

5 The implantable sensor may further comprise at least one radiation-detectable marker and/or physical features to allow deployment with at least one pair of electrodes separated in an anterior-posterior dimension.

10 The means for providing a drive signal may be configured to deliver a sinusoidal waveform and the sensor further comprises means for cycling through each electrode pair taking impedance measurements or capacitive measurements.

15 The implantable sensor may further comprise means for performing an impedance to distance calibration based on initial resting dimensions of the electrodes, and to perform a geometric reconstruction based on the assumption that the blood vessel has an elliptical shape.

At least two electrodes may be spaced apart in the longitudinal direction of the vessel.

20 The implantable sensor may further comprise means for processing data from the electrodes on the basis of impedance planimetry.

The implantable sensor may further comprise means for applying an alternating current, AC, across an outer pair of the plurality of electrodes.

25 The implantable sensor may further comprise means for measuring AC voltage between an inner pair of the plurality of electrodes, the inner pair positioned between the outer pair of electrodes.

30 In accordance with the present invention there is further provided a blood vessel monitoring system comprising at least one implantable sensor of any preceding claim, and a remote processor configured to receive the communicated data and calculate distance between the electrodes based on the measured impedance or the measured capacitance.

The remote processor may be further configured to estimate vessel diameter based on measurements of impedance and capacitance between at least two of the plurality of electrodes.

The remote processor may be further configured to determine cross-sectional area at a mid-point between said electrodes.

5 The remote processor may be further configured to select a pair of electrodes from the plurality of electrodes to which drive signals are to be delivered.

The remote processor may be further configured to estimate blood velocity from the calculated distance between the electrodes.

10 The remote processor may be further configured to estimate a pressure gradient from the calculated distance between the electrodes.

In accordance with the present invention there is further provided a blood vessel monitoring system comprising:

15 a plurality of implantable electromagnetic beacon transponders for placement in a blood vessel, on, adjacent or in a blood vessel wall, the transponders adapted to emit a signal when excited;  
an electromagnetic source for exciting the transponders; and  
a sensing array to receive emitted signals and monitor relative positions of the implanted  
20 transponders.

The sensor array may be configured to detect a resonant frequency of each transponder to differentiate the transponders.

25 The blood vessel monitoring system may further comprise means for determining a cross sectional area of the vessel.

The blood vessel monitoring system may further comprise means for determining the blood vessel diameter based on the relative positions of the implanted transponders.

30 In accordance with the present invention there is further provided an implantable sensor for implantation in a vessel, comprising:

a plurality of electromagnetic beacon transponders for placement on, adjacent or in a vessel wall, the electromagnetic beacon transponders adapted to emit a signal when excited by electromagnetic radiation.

5 The implantable sensor may further comprise a battery power source.

The implantable sensor may further comprise a data processing subsystem.

The implantable sensor may further comprise a communications subsystem.

10 In accordance with the present invention there is further provided a vascular monitoring method comprising:

implanting a plurality of electrodes within a vessel, on, in or adjacent a vessel wall;  
providing a drive signal to the electrodes;

15 measuring at least one of impedance and capacitance between at least two of the plurality of electrodes; and  
wirelessly communicating data from within the vessel.

20 The method may further comprise calculating the distance between the electrodes based on the measured impedance or the measured capacitance.

The method may further comprise estimating vessel diameter based on measurements of impedance or capacitance between at least two of the plurality of electrodes.

25 The method may further comprise determining cross-sectional area of the vessel's lumen based on said impedance or capacitance.

The method may further comprise selecting a pair of electrodes from the plurality of electrodes and delivering drive signals to the selected pair.

30 The method may further comprise estimating blood velocity from the calculated distance between the electrodes.

The method may further comprise estimating a pressure gradient from the calculated distance between the electrodes.

5 The method may further comprise maintaining at least one reference electrode at a fixed distance from one of the electrodes and measuring at least one of impedance or capacitance between said electrode and said reference electrode.

The method may further comprise calibrating measurements between the plurality of electrodes using a measurement of impedance or capacitance between said electrode and said reference electrode.

10 The method may further comprise processing the measured electrical parameter to monitor variations in the conductivity of the intervening media and to apply a correction factor accordingly.

The method may further comprise wirelessly communicating the measured impedance and/or capacitance.

15

The method may further comprise storing the measurements.

The method may further comprise processing the measured data.

20 The method may further comprise wirelessly receiving data from a remote transmitter.

The method may further comprise executing an algorithm to correct the measurements for effects of fouling and/or endothelialisation on electrode surfaces.

25 Executing the algorithm may include one or more of the steps of performing impedance-to-distance calibration based on resting dimensions; salinity recalibration with scales impedance, measurements with reference change, geometric reconstruction with elliptical assumption, fouling detection and rejection according to electrode geometry, preferably with data from three or more electrodes to reconstruct an ellipse, additional data used to detect and reject fouling.

30

The method may further comprise performing data correction with parallelogram edge and diagonal correction, by averaging opposed parallelogram sides.

The method may further comprise performing ellipse reconstruction to model a vessel shape, based on chordal lengths such as parallelogram side calculations.

5 The method may further comprise applying a correction to compensate for change from a round to elliptical cross-sectional shape of the vessel.

The method may further comprise comparing a parameter between multiple pairs of electrodes.

10 The method may further comprise determining a pair of electrodes which is most closely aligned with a selected axis of the vessel.

The method may further comprise determining vessel collapsibility or deformity over at least one respiratory cycle.

15 The method may further comprise delivering a sinusoidal waveform and cycling through each electrode pair taking impedance measurements or capacitive measurements.

20 The method may further comprise performing an impedance to distance calibration based on initial resting dimensions of the electrodes, and performing a geometric reconstruction based on the assumption that the blood vessel has an elliptical shape.

The method may further comprise processing data from the electrodes on the basis of impedance planimetry.

25 The method may further comprise applying an alternating current, AC, across an outer pair of the plurality of electrodes.

30 The method may further comprise measuring AC voltage between an inner pair of the plurality of electrodes, the inner pair positioned between the outer pair of electrodes.

In accordance with the present invention there is further provided a blood vessel monitoring method comprising:

implanting a plurality of implantable electromagnetic beacon transponders in a blood vessel, on, adjacent or in a blood vessel wall, the transponders adapted to emit a signal when excited;

exciting the transponders; and

5 receiving emitted signals and monitoring relative positions of the implanted transponders.

The method may further comprise detecting a resonant frequency of each transponder to differentiate the transponders.

10 The method may further comprise determining a cross sectional area of the vessel.

The method may further comprise determining the blood vessel diameter based on the relative positions of the implanted transponders.

15 We describe in various embodiments a blood vessel monitoring system comprising:

a support structure configured to engage a vessel wall,

a plurality of electrodes supported by the support structure,

a drive circuit for delivering drive signals to the electrodes,

a signal processing circuit for processing electrode parameters resulting from the drive

20 signals to determine distance between the electrodes and estimate a vessel dimension,

a communications circuit for communication with an external component.

Preferably, the signal processing circuit is configured to monitor impedance between electrodes as representative of vessel deformation.

25

Alternatively, the signal processing circuit is configured to determine capacitance between the electrodes, and the signal processing circuit is configured to monitor capacitance between electrodes as representative of a vessel dimension.

30 The support structure may be configured with a radial elasticity and compliance to have insignificant impact on the motion of the vessel wall. Alternatively, the support structure may be configured to alter normal physiologic motion of the vessel in a consistent and predictable manner and the signal processing circuitry is configured to apply a correction factor to the determination of vessel diameter or collapsibility.

35

In one aspect, the electrodes are arranged to engage a vessel wall at a first location and the support structure is arranged to engage a vessel wall at a second location, the first location being longitudinally separated from the second location by a distance selected such that natural movement of the vessel wall at the first location is not constrained by the support structure.

5 Preferably, each electrode is coupled to the support structure by a connecting strut extending from an anchored part of the structure, the connecting strut being flexible or biodegradable and configured to bias the electrode into engagement with the vessel wall.

10 In other embodiments, the electrodes are mounted to a compliant support structure with sufficient elasticity to collapse and expand with the vessel without constraining the vessel's natural physiological shape changes. The support structure may be a stent-like flexible, elastic, cylindrical structure comprised of a slotted tube, interconnecting struts, or mesh, and/or having a continuous zig-zag or sinusoidal geometry. Notably, the support structure does not provide a scaffold to maintain luminal patency as does a stent, but rather is designed to minimize any interference with  
15 the natural collapsing of the vessel in correlation with fluid volume. In some embodiments the support structure will alter natural vessel collapse or expansion by a known factor which can be accounted for by the processing circuit in determining vessel diameter or collapsibility.

20 Preferably, at least one connecting strut may be cantilevered from the anchored part of the structure.

Preferably, at least one strut may comprise an anchoring feature for engagement directly with a vessel wall, such as a barb or hook, or is configured to endothelialize on a vessel wall.

25 In one example, at least some of the electrodes may have an anti-fouling surface.

Preferably, the anti-fouling surface may include one or more selected from carbon nanotubes, conductive polymers, hydrogels, conductive hydrogels, bioactive coatings, and a tissue engineered neural interface.

30 Preferably, the system may comprise reference electrodes mounted to be a fixed distance apart, and the drive circuit and the signal processing circuit are configured to drive the reference electrodes and process resultant electrical parameters to monitor variations in the conductivity of the intervening media (blood, tissue etc.) and to apply a correction factor accordingly.

35 The reference electrodes may be mounted to be spaced apart in a longitudinal direction.

There may be a plurality of pairs of electrodes mounted circumferentially, and the circuits may be configured to estimate distances across different diagonals or chords.

5 Preferably, at least two electrodes are spaced apart in the longitudinal direction and the signal processing circuit is configured to drive and process data from the electrodes on the basis of impedance planimetry.

10 The electrodes may be mounted and the signal processing circuit is configured to determine cross-sectional area at a mid-point between said electrodes.

Preferably, the signal processing circuit is configured to estimate vessel diameter based on measured chordal distances.

15 Preferably, the signal processing circuit is configured to estimate a parameter value derived from distance, for example blood velocity and/or pressure gradient across a vessel. Preferably, the signal processing circuit is configured to provide real time measurements.

20 Preferably, the signal processing circuit is configured to execute an algorithm to reduce effects of fouling and/or endothelialisation on electrode surfaces.

Preferably, the algorithm includes one or more of the steps of performing impedance-to-distance calibration based on resting dimensions, salinity recalibration with scales impedance  
25 measurements with reference change; geometric reconstruction with elliptical assumption, fouling detection and rejection according to electrode geometry, preferably with data from three or more electrodes to reconstruct an ellipse, additional data used to detect and reject fouling.

Preferably, the signal processing circuit is configured to perform data correction with  
30 parallelogram edge and diagonal correction, by averaging opposed parallelogram sides.

Preferably, the signal processing circuit is configured to perform ellipse reconstruction to model a vessel shape, based on chordal lengths such as parallelogram side calculations. The circuits may be configured to apply a correction to compensate for change from a round to elliptical shape of  
35 the support structure in end view.

The circuits may be configured to allow selection of various pairs of electrodes to which drive signals are delivered. The signal processing circuit may be configured to compare a parameter between the various pairs of electrodes.

5 Preferably, the signal processing circuit is configured to determine a pair of electrodes which is most closely aligned with a selected axis of the vessel, preferably an anterior-posterior axis. The circuits may be configured to perform said processing by determining a major axis of an ellipse modelling shape of a blood vessel.

10 Preferably, the signal processing circuit is configured to determine vessel collapsibility or deformity over at least one respiratory cycle.

The support structure may be arranged with radiation-detectable markers and/or physical features to allow deployment with at least one pair of electrodes separated in an anterior-posterior  
15 dimension.

Preferably, the drive circuit is configured to deliver a sinusoidal waveform for at least one contact electrode pair and at least one capacitive electrode pair, and the drive and signal processing circuit is configured to cycle through each electrode pair taking impedance measurements and capacitive  
20 measurements.

Preferably, the signal processing circuit is configured to perform an impedance to distance calibration based on initial resting dimensions of the electrodes, and to perform a geometric reconstruction based on the assumption that the blood vessel has an elliptical shape.  
25

The electrodes may include at least two passive electromagnetic transponders, and the system may comprise external drive coils and a sensing array to monitor relative positions of the implanted transponders. Preferably, the sensor array is configured to detect a resonant frequency of each transponder to differentiate the transponders.  
30

Preferably, there are greater than two transponders, and the data processor is configured to determine cross sectional area of the vessel.

In another aspect, the disclosure provides a non-transitory computer readable medium comprising  
35 software executable by a digital processor to perform operations of a signal processing circuit of a system of any embodiment.

## BRIEF DESCRIPTION OF THE DRAWINGS

The disclosure will be more clearly understood from the following description of some embodiments thereof, given by way of example only with reference to the accompanying drawings in which:

Fig. 1 is a schematic diagram showing a system of the disclosure incorporating an implantable device;

Fig. 2 is a block diagram showing a circuit of the implantable device;

Fig. 3 is a perspective view of the implantable device;

Fig. 4 is a perspective view of an alternative implantable device, without longitudinal struts;

Fig. 5 is a diagrammatic end view showing how the electrodes are arranged circumferentially and how they can be driven and signals processed for different permutations of pairs;

Fig. 6 is a diagrammatic side view of an alternative device, in which the sensing electrodes are distributed longitudinally along the vessel wall, for impedance planimetry measurements;

Fig. 7 is a circuit diagram of a switching array for the sensing electrodes of the devices of any embodiment;

Fig. 8 is a plot of impedance vs. time for a test using the device of Figs. 1 to 3;

Fig. 9 is a plot of the conductivity of blood as it changes with velocity;

Fig. 10 is a diagram showing the velocity profile across the vessel;

Fig. 11 is a flow diagram showing operation of a signal processor for processing data from the sensing electrodes;

5 Figs. 12 to 16 are sets of diagrams and equations for data processing with computation and correction;

Fig. 17 is a diagrammatic side view of a device having capacitance sensing;

10 Fig. 18 is a diagram illustrating an alternative system of the disclosure for monitoring IVC diameter and collapsibility, in this case involving electromagnetic devices;

Fig. 19 is a diagram showing operating principle of the Fig. 18 system, using low frequency magnetic techniques, in this case wireless;

15 Fig. 20 is a diagram showing a further device also using low frequency magnetic techniques, in this case wired;

Fig. 21 is a pair of diagrams illustrating some operating parameters; and

20 Fig. 22 is a diagram showing antennas for RFID type sensing; and

Fig. 23 is a plot of phase difference vs. time.

#### DETAILED DISCLOSURE

25 In various embodiments blood vessel monitoring systems are described which include implantable devices with a number of electrodes, a data processing subsystem, a communications subsystem, and a battery power source. The implantable device has a stent-like support structure for both anchoring and positioning the device within a vessel such as the IVC, and supporting the electrodes and some internal electronics for driving the electrodes and routing data externally. The support  
30 structure is flexible and elastic, preferably having little influence on the normal movement and shape of the IVC. In most cases the implantable device is deployed in a manner similar to a stent, within a catheter, and it expands radially to engage the blood vessel upon withdrawal of a sheath.

### Implantable Devices

Referring to Figs. 1 to 3, a system of the disclosure is shown. The system comprises an implantable device 1 having sensing electrodes 2 coupled to a stent-like support or anchor structure 3. One of the struts 5 also has a reference electrode 9, for use in correcting for variations in blood conductivity. There are electrical connections to an electronic circuit in a housing 4, containing power 4(a), microcontroller 4(b) and communications 4(c) components as shown in Fig. 2, all mounted on the anchor structure 3. The implantable device 1 communicates wirelessly to an external console 7, which includes data processing circuitry as well as circuits for communication to cloud servers 8. Remote interfaces are provided for use by care providers, nurses, physicians, and the patient which can receive and/or transmit data from the external console 7 via a cloud server 8.

Referring especially to Fig. 3, in the implantable device 1 the multiple electrodes 2 and 9 are mounted on the cantilevered longitudinal struts 5 extending from the support structure 3. There are active and reference electrodes 2 and 9 mounted a short distance apart on one strut 5 in a manner whereby their separation is fixed. This allows calibration to detect changes in conductivity between the electrodes, so that impedance measurements between electrodes having a variable separation can be corrected.

However, in another embodiment shown in Figs. 1 and 4 there may be electrodes 2 and 9 mounted directly on a structure 21. The anchor structure 21 has a sinusoidal wave-like pattern for radial expansion and collapse. In this case the structure 21 has a low radial force to avoid 'stenting' the vessel and preventing the vessel from moving (and thus negating the sensing). Where particularly low radial force is required, then additional means of anchoring are preferably incorporated to prevent the device from migrating, such as one or more of the following:

- Anchor spikes such as sharp spikes to interact with the vessel wall.
- Anchor features to anchor or hang the device from the renal vein or veins.
- High friction surfaces to interact with the wall.
- Ingrowth-promoting material, such as a polyester, to accelerate tissue ingrowth.
- Oversizing – low radial force could be maintained while still setting the natural uncompressed diameter of the device to much greater than the maximum diameter of the vessel.

An implantable device may have an arrangement of electrodes mounted directly to the support structure 21 as shown in Fig. 4 in addition to electrodes mounted on longitudinal struts as shown

in Fig. 3, the two sets being used at the same time or in an alternating manner for redundancy, calibration, comparison or averaging for higher accuracy, or other purposes.

Because the electrodes 2 of the implantable device 1 are insulated from or arranged outside of the support structure 3, any potential electrical interference from the structure and electronics is minimized, thereby allowing measurements to be taken in a portion of the vessel not affected by the support structure 3. Advantageously, there is physical separation of the electrodes from the support structure so that any distortion of vessel shape/collapsibility by the support does not influence the vessel shape where electrodes are located.

In various examples, the electrodes 2 are disposed at the tips of elongated flexible struts (numbering between two and eight) which are biased outwardly in a cantilevered manner into contact with the vessel wall and are sufficiently flexible to allow the electrodes 2 to move inwardly and outwardly with the natural collapse and expansion of the vessel. The struts preferably have a length selected such that the electrodes 2 are positioned far enough from the support structure 3 that in the region engaged by the electrodes 2 the vessel undergoes its natural collapse and expansion without being constrained or distorted by the support structure 3, which is preferably at least about 30 mm in length.

The support structure 3 is preferably stent-like and may take any suitable stent or anchor type form, as is well known in the art, providing support for the electrodes in a secure manner within the blood vessel. The support structure properties may be of the type known for supporting IVC filters for example. The structure 3 supports the electronics unit 4 containing the circuit which provides electrode drive signals, and performs signal processing from them and wireless delivery of data to the external console 7. If the support does influence vessel shape, it preferably has a known and predictable amount that can be characterised empirically in testing and corrected for in the calculation of vessel diameter, and the system is preferably programmed to compensate for it. The stent may be either super flexible/compliant so that it does not influence vessel shape significantly, or the amount of distortion should be predictable and included in the calculation.

Some or all electrodes may be mounted to the inside of the support structure (closer to the centre of the lumen) in which case the thickness of the support structure would be corrected for. Alternatively, at least some may be mounted to lie alongside the members, at the same radial

position. In a further example, at least some may be radially outside the members and hence in contact with the vessel wall in use.

5 The support structure may have one, two, or more rings or hoops and interconnecting longitudinal members.

Each longitudinal strut 5 has a Nitinol spine, coupled to which are insulated leads for the electrodes 2.

10 In some embodiments, the electrodes 2 and/or the longitudinal strut 5 may be configured to be fixed to the vessel wall to ensure that the electrode moves with it. For example, the electrode 2 and/or the longitudinal strut 5 may have barbs, hooks, or other features on its outer side that penetrate or engage the wall tissue. The electrode 2 and/or longitudinal strut 5 may alternatively or additionally be coated with a material that adheres to tissue or encourages tissue growth around  
15 or into these components. In other embodiments the longitudinal strut 5 may have a tip extending beyond the electrode 2 and configured to penetrate into the vessel wall.

The structure 3 diameter is preferably in the range of 5 mm to 40 mm, and the length is preferably in the range of 10 mm to 40 mm.

20 In various embodiments, the support structure 2 may have one, two, or more rings or hoops and interconnecting longitudinal members or struts between the hoops, the hoops being resiliently biased radially outwardly in a stent-like manner to engage the vessel wall and securely anchor the device 1 in the vessel. The rings or hoops may have a sinusoidal, zig-zag, or other radially  
25 collapsible configuration to facilitate delivery through the vessel to the desired location of placement and to impart a relatively consistent radial fixation force against the vessel wall over a wide range of diameters.

The support structure may also have other anchoring features such as those which are known for  
30 IVC filters and commonly known in the art.

The microcontroller, measurement circuitry, the communication sub-system, and the battery are located within the electronics enclosure 4, which is hermetically sealed. An alternating current is sequentially applied between pairs of electrodes 2 and the measurement circuitry determines an

impedance measurement between at least two of the electrodes 2. If it is assumed that the blood conductivity is constant, the impedance measurement between the active electrodes is related to distance between them. It is therefore possible to obtain information on the relative distances between electrodes, allowing IVC diameter and possibly also other data such as cross-sectional area and shape to be determined. The inclusion of a reference electrode 9 enables the system to accommodate changes in the conductance of blood as the reference electrode 9 is at a known distance from a sensing electrode 2 and internal calibration is performed automatically. The reference electrode 9 also facilitates some calculations to reject or correct for any changes with endothelialisation and the resulting changes in conductance.

Measurement of IVC diameter or collapsibility has certain unique considerations and challenges not present in the measurement of other blood vessels. One such challenge is the asymmetrical shape and dynamics of the vessel as it collapses and expands. The IVC tends to collapse in the anterior-posterior direction, moving from a more circular cross-section at higher blood volumes to a flattened, oval cross-section at lower blood volumes. Thus the direction of measurement is an important factor. The device 1 may be specially configured to enable the determination of the vessel dimensions and/or collapsibility in a desired direction (e.g. anterior-posterior). For example, the support structure 3 may have radiopaque or ultrasonic markers to guide the user during placement so that it may be oriented with electrodes 2 along the desired axis. Alternatively, the support structure 3 may be configured to self-orient by means of varying circumferential radial force, into a desired rotational position in the IVC upon deployment such that a pair of the electrodes 2 are disposed along the anterior-posterior axis.

In various embodiments, the implantable device has a circumferential array of electrodes disposed at a predetermined circumferential spacing from each other as shown in Figs. 3 and 4. For example, three, four, five, six or more electrodes may be arranged around the circumference of the device 1. The system may be configured to allow selection of various pairs of electrodes between which impedance or other parameters may be measured. The maximum and minimum distances between various electrode pairs may thus be determined so that the pair most closely aligned with the anterior-posterior axis may be selected. Such selection may be performed manually by the user, or the system may be configured to automatically sample various electrode pairs and determine through software which pair is oriented closest to the desired axis of measurement, and/or between which pair the diameter variation or collapsibility is greatest or lowest. This embodiment could

also be utilized to estimate irregular shapes of IVC cross section which may be useful in understanding particular blood volume patient states.

## 5 Sensing and Blood Conductivity Correction

The presence of multiple electrodes facilitates numerous pairs to be selected and impedance measurements taken and subsequently converted into distances and then derived parameter values. As can be seen in Fig. 5, with six electrodes 2, there are multiple ways to calculate the position of any one electrode. All or a portion of the distances between an electrode and each other electrode on the implant may be calculated. This over-constrained problem provides redundancy in the system and allows for errors or drift to be corrected for in the algorithms.

However, blood conductivity is reliant on a number of blood properties which may vary over the course of the day/year:

- 15 – Glucose may vary over the day by 50-100%. It has a direct effect on conductivity, different ranges for normal/ diabetes patients.
- Orientation of Erythrocyte cells affects conductivity and dielectric properties.
- Environmental factors, such as exposure to pollutants (e.g. Benzene), can cause 40% variation.
- 20 – Blood Type: Dielectric properties can vary by up to 50% depending on A, B, AB and O Blood type.
- Haematocrit may vary annually by approximately 15% due to blood loss.
- Support structure material may also affect electrical conductivity.

25 Given blood conductivity variability, it is preferred that the measurements have an empirical correction factor accounting for blood conductivity. This is achieved by use of the reference electrodes 9 within the structure or on a linked structure which maintains them at a fixed separation from an adjacent sensing electrode 2.

30 The correction factor is preferably obtained by fixing two electrodes a set distance apart, measuring blood impedance and using this as a correction. Such reference electrodes are preferably spaced-apart in the longitudinal direction because it is simpler to maintain a fixed separation in this direction. However, they may alternatively be radially spaced-apart.

The IVC contracts and expands with each respiration (and to a lesser extent with each heart beat). Regular IVC diameter measurements are thus taken over multiple respiratory cycles allowing for the recording of maximum and minimum diameters, with which a measure of collapsibility can be determined.

5 The recorded data may be stored in a memory device within electronics enclosure 4, and transmitted via Radio Frequency (RF) communication to the external console for processing and display. Alternatively raw measured signals may be transmitted upon measurement directly to the external console where they are stored and processed.

10 Impedance Planimetry Approach  
In other embodiments, at least some of electrodes 2 are arranged longitudinally and in-line, at fixed distances apart. Fig. 6 shows a device 30 having a stent-like support 31, a substrate 32, power electrodes 33, and sensor electrodes 34. The IVC cross-sectional area measurement technique is based on impedance planimetry. An alternating current (AC) is applied across the outer powered pair of electrodes 33 while AC voltage measurements are made between the inner pair of sensor electrodes 34 positioned mid-way between the powered electrodes. The AC voltage measurement is inversely related to the cross-sectional area of the IVC, assuming a constant AC power source and a medium of constant conductivity.

20 This embodiment is advantageous because it uses impedance planimetry without the use of a balloon filled with media within which to set up the electric field. In the present disclosure, the existing blood flow within the vessel is used to do this. A constant current source is applied at the power electrodes shown and the sensing is done between them using the sensor electrodes shown.  
25 An advantage of this system is that it gives an actual area of the lumen (irrespective of shape), it could also be deployed over a larger / longer area, and it may require less processing power and post processing.

The AC voltage measurements allow estimation of the extent of the diameter of the vessel at the mid-point between the power electrodes 33. It is important that the voltage drop across the medium is generated from a constant AC current source. The fact that the conductivity of the blood is not constant may give rise for a need to apply a correction factor (and potentially using the electrode array as a set of reference electrodes) as described above.

### Switching Array

Fig. 7 shows a switching array 40 for driving electrodes of any embodiment. In the switching array 40 the switching controller runs through the combinations of source detector pairs by using a series of programmable solid state switches to create an electrical path between the source and an electrode and also creating an electrical path from the opposite paired electrode current detection path to ground to close the circuit.

The switching array 40 is connected to impedance measurement circuitry, which preferably includes an impedance analyser chip, and a SoC (System on chip) for the main data processing within the electronics enclosure 4, and from there data is communicated wirelessly to the external console.

In exemplary embodiments the microcontroller 4(b) (Fig. 2) delivers a 100kHz sinusoidal waveform that consumes 2 mW for the contact electrodes, and 2  $\mu$ W for capacitive electrodes. The algorithm cycles through each electrode 2 pair taking impedance measurements.

The drive frequency is preferably at least 100 kHz.

### Data Processing

In executing an algorithm to determine collapsibility the following factors and considerations are applied by the data processor:

- expected respiration and cardiac cycle periods;
- expected maximum and minimum IVC diameters;
- corrections for blood conductivity and conductivity changes due to gradual endothelialisation using reference electrode measurements;
- any calibrations that may be required at implantation; and
- corrections facilitated due to the over constrained nature of the solution set and multiple measurements for each dimension.

The recorded data is stored and transmitted via Radio Frequency (RF) communication to the external console 7. Some data processing may be done with a processor or processing circuitry in the implant prior to transmission externally. Optionally the data may be stored in a memory device on the implant. Alternatively, only raw electrode signals correlated with measured electric parameters such as impedance or capacitance are transmitted wirelessly, and the required data

processing is performed by processing circuitry in the console 7, which may be a computer, or a smartphone, or any other computing device.

5 It will be understood that in any of the embodiments described herein, the terms “signal processing circuit”, “processing circuitry,” and the like may refer to circuitry and/or processors within the electronics housing 4 on the implant, in the external console 7, or combinations thereof, and the data processing and calculations performed by the processing circuitry may be performed entirely within the implant, entirely in the external console, or partially in each. Further, in some  
10 Bluetooth, wireless or wired communication, and some or all of the data processing referred to herein may be performed on such remote systems.

The impedance to distance calibration is based on the initial resting dimensions of the electrodes. If the impedance of the blood changes with respect to time, all of the impedance measurements  
15 are scaled with respect to the reference electrode set. A geometric reconstruction may be performed based on the assumption that the IVC has an elliptical shape. Fouling detection and compensation may be performed with either of two methods, geometric or time-dependent, as described more fully below.

20 Fig. 8 is a plot of impedance vs. time for an animal study using the device shown in Fig. 4, showing the impedance between the pairs of electrodes 2 varying in synchronism with the IVC distension. It may be seen that the impedance between pairs of electrodes varies as the wall of the IVC moves. The frequency of the variation in the wall of the IVC and therefore the signal, is determined by the rate set on the mechanical ventilator (11 breaths per minute in this case). When the ventilator is  
25 stopped (simulating breath hold) the variation in the impedance stops and recommences when respiration is restarted, again demonstrating that the signal seen is a direct result of the IVC wall motion induced by the ventilator.

In diagnosing and monitoring heart failure, it may be valuable to determine other parameters such  
30 as blood flow velocity and/or pressure gradient, or  $\Delta P/\Delta x$ . Fig. 9 shows the relationship of blood conductivity as a function of flow velocity. It may be seen that conductivity increases with flow velocity. This relationship presents the opportunity to determine blood flow velocity based upon the determination of impedance between electrodes. From blood flow velocity and vessel radius, pressure gradient may be calculated.

Fig. 10 shows several of the key parameters for the data processing performed by the system when calculating the blood flow from the individual velocities inferred between pairs of electrodes. It will be seen that the radius “R” at any point in time is a parameter in calculation of the velocity for any radial position “r”, which in turn is related to the pressure gradient  $\Delta P/\Delta x$ . In more detail:

$$v_m = \frac{1}{4n} \frac{\Delta P}{\Delta x} R^2$$

where  $\frac{\Delta P}{\Delta x}$  = pressure gradient, and  $n$  = viscosity and,

$$v(r) = v_m \left[ 1 - \frac{r^2}{R^2} \right]$$

gives the velocity profile.

This information may be used in combination to compute the blood flow rate. Vessel diameter may be determined using the impedance and, using different chords as shown in Fig. 5 through the cross section and the variation of conductance with velocity, each chord could be assigned a velocity. These velocity profiles could then be combined to compute a blood flow rate, or pressure gradient, or flow velocity.

The switching array sequentially connects each pair of electrodes to the impedance analyser chip within the electronics enclosure 4, which determines the impedance measurement for that pair of electrodes. Each of these results is then recorded on the SoC (which is part of the communications block 4(c)) which also performs the communications function to transmit the stream of data to the external console 7.

One approach for this device is to allow the electrodes to endothelialize and therefore reduce the risk of thrombus or embolization. This does however bring the challenge of managing the potential changes in impedance due to the varying media and tissue thickness between the electrodes. A reference electrode may be utilized as a solution to this issue as described above. An alternative option is to prevent the electrodes from being incorporated into the vessel wall. In this situation the electrodes are exposed to blood and may be subject to fouling due to thrombus formation. Anti-fouling coatings may be used for the implanted electrode surfaces. The coatings may comprise one or some of carbon nanotubes, conductive polymers, hydrogels, conductive hydrogels, bioactive coatings, and a tissue engineered neural interface.

One or more of the following approaches may be used to compensate or correct for the effects of fouling.

- Impedance to distance calibration based on resting dimensions
- Salinity recalibration- scales impedance measurements with reference change
- 5 – Geometric reconstruction with elliptical assumption
- Fouling detection and rejection
  - Geometric
    - Requires data from 3 electrodes to reconstruct ellipse, and compensation data used to detect and reject fouling
  - 10 • Time-Dependent
    - Uses varying time scales to detect fouling

Fig. 11 is a flow diagram for the overall data processing. Initially, the current signals are read from between each successive pair of electrodes in a drive scheme set by the microcontroller and the switching array. As shown in Fig. 5 there may be trans-vessel flow chords 27, mid-vessel flow chords 26, and/or wall flow chords 25. As a known voltage is applied between the electrodes of each pair and the current is detected, the resistance and hence distance can be determined by comparing the reference impedance to the impedances calculated from each electrode pair adjusted for any fouling correction.

20 The system processes derived data to recognize the asymmetrical shape change in the IVC, specifically the use of multiple electrodes to get dimensional measurement in multiple axes and reconstructs an ellipse from these dimensions.

25 There are preferably a sufficient number of electrodes to minimize the error of being oriented off-axis (i.e. not aligned with anterior-posterior axis of the vessel). There is preferably a minimum of four electrodes, but preferably at least six, arranged circumferentially around the implant, and the sampling is preferably of all possible electrode combinations in order to model the ellipse. The fouling detection and correction in software is very advantageous, and eliminates outliers in the  
30 detected data.

Also, advantageously in some embodiments the data processor is programmed to determine flow rate and/or pressure gradient in addition to vessel dimension, as described above.

The length of the structure helps it to conform to IVC or other blood vessel, and this is preferably in the range of 10 mm to 50 mm. For optimum performance, there is preferably one structure peak per electrode.

- 5 The processor is programmed to sweep through frequencies for fouling elimination/correction, as fouling will be detected more for some frequencies than others.

In the next step there is a fouling check, in which any outliers are eliminated. There is then edge and diagonal correction, followed by ellipse reconstruction.

10 Fig. 12 shows the construction of a parallelogram from chordal lengths  $l_{12}$ ,  $l_{34}$ ,  $l_{14}$ , and  $l_{23}$  as determined by the impedance between two pairs of electrodes. A correction is then applied to both parallelogram edges and diagonals, in which opposed lengths are added and the sum divided by two. The parallelogram edge correction is thus based on the fact that the opposing parallelogram  
15 edges are equal to each other. Basic geometrical expressions as illustrated are used to determine the diagonals of the parallelogram. The subsequent diagonal correction is based on the minimal correction needed such that the intrinsic geometric relationship between parallelogram edges and diagonals can be satisfied.

20 Fig. 13 shows ellipse reconstruction from the parallelogram, in which there is correction applied to compensate for change from a round (top left diagram) to elliptical (top right) shape of the support structure in end view. Two criteria for reconstructing the ellipse are:

- The reconstructed ellipse must encompass the parallelogram (the ellipse outline needs to pass through the four corners of the parallelogram). There is a stretch in an “X” direction,  
25 the longer diagonal or major axis of the parallelogram.
- When the reconstructed ellipse is transformed to its un-deformed circular shape, the diagonals of the corresponding parallelogram need to form an angle of  $90^\circ$ .

With the two criteria above, the reconstructed ellipse is uniquely defined.

30 The ellipse reconstruction algorithm is as follows, in which:  
 a and b are the parallelogram long and short side lengths, and c and d are the major and minor axes;  
 the electrodes are referred to as electrodes 1, electrode 2, electrode 3, and electrode 4 in sequence circumferentially around the vessel.

Define the included angle of the diagonals as:

$$\Phi = \frac{a \cos(d^2 + c^2 - 4a^2)}{2dc}$$

Define the point 1 position and point 2 position as  $\begin{bmatrix} x_1 \\ y_1 \end{bmatrix} = \begin{bmatrix} \frac{c}{2} \\ 0 \end{bmatrix}$ ,  $\begin{bmatrix} x_2 \\ y_2 \end{bmatrix} = \begin{bmatrix} \frac{d}{2} \cos(\Phi) \\ \frac{d}{2} \sin(\Phi) \end{bmatrix}$ ,

5 respectively.

Define an unknown  $\Theta$  to be solved later.

Two virtual positions which used to help reconstruct the ellipse are:

$$10 \quad \begin{bmatrix} x_1' \\ y_1' \end{bmatrix} = \begin{bmatrix} \cos(\Theta) & \sin(\Theta) \\ -\sin(\Theta) & \cos(\Theta) \end{bmatrix} \begin{bmatrix} x_1 \\ y_1 \end{bmatrix} \quad \begin{bmatrix} x_2' \\ y_2' \end{bmatrix} = \begin{bmatrix} \cos(\Theta) & \sin(\Theta) \\ -\sin(\Theta) & \cos(\Theta) \end{bmatrix} \begin{bmatrix} x_2 \\ y_2 \end{bmatrix}$$

Based on the position relationship of electrode 1 and electrode 2 at unreformed position, the following relationship needs to be satisfied:

$$15 \quad x_1' y_1' + x_2' y_2' = 0$$

$\Theta$  can be solved by the equation above.

The corresponding major and minor axis of the ellipse are solved by

$$20 \quad \text{Major axis} = \max\left(\sqrt{x_1'^2 + x_2'^2}, \sqrt{y_1'^2 + y_2'^2}\right)$$

$$\text{Minor axis} = \min\left(\sqrt{x_1'^2 + x_2'^2}, \sqrt{y_1'^2 + y_2'^2}\right)$$

Fig. 14 shows the effects of noise and fouling on the ellipse.

25 Referring to Figs. 15 and 16, if the two edges associated with Electrode  $i$  ( $l_{i-1}$  and  $l_{i+1}$ ) are significantly larger than their corresponding opposite edges, the processor assumes that there is fouling on electrode. This may be corrected using the parallelogram edge and diagonal correction procedure described with reference to Fig. 12.

30 Fig. 17 shows a further embodiment in which the implantable device 100 has capacitance electrodes or pads. The device 100 consists of conductor pads (electrodes 102), a data processing subsystem, a communications subsystem, and a battery power source contained in a housing 103. The components are housed and incorporated into a stent-like support structure 101 for both anchoring and positioning the device within the IVC, in a manner as described above in any

embodiment. The support structure is flexible and elastic, having little influence on the normal movement and shape of the IVC.

5 The electrodes are positioned such that they lie on the endothelium of the IVC wall on directly opposing interior wall. The electrode is arranged such that it extends outside of the stent support, thus minimising any electrical interference from the structure.

10 The drive circuitry may apply an alternating voltage across the two conductive electrodes, thus creating an effective capacitor with the blood as a dielectric material. The measurement circuit, e.g. an analyser chip, can then measure the capacitance between the electrodes. If it is assumed that the blood dielectric value is constant, the distance (corresponding to the IVC diameter) between the plates can be estimated accurately by measuring the capacitance. It is expected that the use of a capacitance measure may be less influenced by any intervening material (endothelial / blood / other cells).

15 Some or all of the features described above for the embodiments with sensing electrodes to measure impedance apply to this embodiment with capacitive electrodes.

#### Electromagnetic Aspect

20 In other embodiments, power may be provided to sensing electrodes by electromagnetism, and relative movement of beacon transponders may be tracked.

In these embodiments blood vessel monitoring systems include an implantable device with at least one electrode in the form of an electromagnetic beacon transponder, a data processing subsystem, 25 a communications subsystem, and a battery power source. The electrodes are supported by a stent-like support structure for both anchoring and positioning the device within a vessel such as the IVC. The support structure is flexible and elastic, having little influence on the normal movement and shape of the IVC. Some or all of the features described above for the other embodiments may apply for the embodiments with beacon transponders, the transponders being mounted in a manner 30 akin to the mounting of the sensing electrodes of any embodiment.

Referring to Fig. 18 a system 200 is described for providing measurement of IVC lumen diameter and collapsibility. An implantable device 201 comprises a stent-like support structure 202 with peaks 204, and a number of passive beacon transponders arranged 203 around the structure's

periphery. There is an external electromagnetic coil and sensor array 205 linked with a data processing console 206. There is a communications subsystem and power source within one of the transponders 203, or alternatively in a separate hermetically sealed capsule mounted to the support structure.

5 The electromagnetic beacon transponder electrodes 203 are coupled to the stent-like support structure 202 such that they are positioned along the circumference of the IVC endothelium.

10 Each transponder 203 consists of a miniature electrical circuit contained in a sealed glass capsule, measuring approximately 1.85 mm in diameter and 8.0 mm in length. The transponders are preferably passive having no power source and, thus, are excited externally by the flat panel array 205 on which the patient lies. The flat panel 205 houses both a series of electromagnetic source coils and a sensor array. The transponders 203 are excited via the electromagnetic source coils of the array 205 with each transponder emitting a unique resonant frequency signal. The spatial  
15 profile of each resonant signal is detected by the multiple channel sensors, allowing for the position of each transponder to be determined.

Accordingly, the diameter of the IVC may be determined as the distance between opposing transponders 3, the spatial resolution of which is less than 0.25mm. Alternatively, where multiple  
20 beacons are incorporated into the stent support structure 202, it may be possible to infer IVC cross-sectional area.

The data processing functions described above may be applied in any desired combination to this embodiment.

25 Referring to Fig. 19, coils 250 are within the beacon transponders 203 and the magnetic field between them is monitored at the “B amplitude” location. This is in response to a low frequency stimulus. There may be more than two coils, giving multiple axes for 3 dimensional (3D) positions. In this case the communication is wireless to a host which performs the data processing. The coils  
30 may have a 19 kHz resonant frequency, and the external stimulating array may have 32 coils to reconstruct position

Referring to Fig. 20, in another embodiment an implanted device 300 has coils 301 and a sensing coil 303 is connected by a wired link 305 with an amplifier connected to signal processing circuits. In this case it is expected that a stronger external magnetic field may be applied.

5 Referring to Fig. 20, in another embodiment an implanted device configuration 300 has a pair of coils 301 used for excitation (transmission) and an implanted sensing coil 303. The sensing coil 303 is connected by a wired link 305 to the outside circuit with an amplifier connected to the signal processing circuits. The excitation magnetic field generated by the excitation coils 301 is assumed to vary linearly across the range of possible sensing coil locations and, in order to  
10 induce a measurable voltage in the sensing coil, the excitation current in the coils 301 is varied using a known resonance frequency (e.g. 19kHz). The variation of the excitation magnetic field across space causes spatially-dependent magnitude shifts in the sensing coil 303 and hence the location of the sensing coil 303 within the body can be resolved. Pre-amplification is used to improve the signal-to-noise-ratio of the sensed signal in the sensing coil 303 and in order to  
15 reduce the necessary magnetic field strength to be created by the excitation coils 301. The same may be achieved through use of multiple array detectors.

Referring to Fig. 21, in an implantable device 350 transponders 351 are mounted around the periphery of an implantable support structure 352. There is an externally-applied magnetic field,  
20 operating at a frequency in the range of 100MHz to 300MHz. In one example, a 1mm difference in separation of two opposing electrodes 351 gives a phase shift of  $0.36^\circ$ . The electrodes 352 are in this case passive, being powered by the external RF field.

A variation on this embodiment is shown in Figs. 22-23, in which an implantable device has  
25 multiple separated antennas 400 and phase difference from the antennas is measured. An external oscillator detects the phases  $\phi_1$ ,  $\phi_2$ ,  $\phi_3$  and in one example operates at 300 MHz, giving a  $0.36^\circ$  phase shift for a 1mm change in position.

The disclosure is not limited to the embodiments described but may be varied in construction and  
30 detail. The term “electrode” in this specification is intended to mean in the relevant context an electrode for either impedance or capacitive measurements or a passive electromagnetic transponder. Various embodiments may include one or more of any of the physical, electrode, of electronic features of any embodiment to achieve the desired result of monitoring a vessel dimension. It is also envisaged that the processor operations to perform re-construction or

modelling of vessel dimensions based on parallelograms and/or ellipses may be performed based on monitoring chords by sensors other than electrodes, such as for example by way of ultrasonic transducers in which time of flight for echo signals or direct transfers across a vessel are monitored.

## CLAIMS

1. An implantable sensor for implantation in a vessel, comprising:
  - a plurality of electrodes for placement on, in or adjacent a vessel wall;
  - 5 means for providing a drive signal to the electrodes;
  - means for measuring at least one of impedance and capacitance between at least two of the plurality of electrodes; and
  - means for wirelessly communicating data from the sensor.
- 10 2. The implantable sensor of claim 1, further comprising means for calculating distance between the electrodes based on the measured impedance or the measured capacitance.
3. The implantable sensor of any preceding claim, further comprising means for estimating vessel diameter based on measurements of impedance or capacitance between at least two  
15 of the plurality of electrodes.
4. The implantable sensor of any preceding claim further comprising means for determining cross-sectional area of the vessel's lumen based on said impedance or capacitance.
- 20 5. The implantable sensor of any preceding claim, further comprising means for selecting a pair of electrodes from the plurality of electrodes to which drive signals are to be delivered.
6. The implantable sensor of any of claims 2 to 6 further comprising means for estimating  
25 blood velocity from the calculated distance between the electrodes.
7. The implantable sensor of any of claims 2 to 6 further comprising means for estimating a pressure gradient from the calculated distance between the electrodes.
- 30 8. The implantable sensor of any preceding claim, further comprising at least one reference electrode maintained at a fixed distance from one of the electrodes and means for measuring at least one of impedance or capacitance between said electrode and said reference electrode.

9. The implantable sensor of any preceding claim, further comprising means for calibrating measurements between the plurality of electrodes using a measurement of impedance or capacitance between said electrode and said reference electrode.
- 5 10. The implantable sensor of any preceding claim, further comprising means for processing the measured electrical parameter to monitor variations in the conductivity of the intervening media and to apply a correction factor accordingly.
- 10 11. The implantable sensor of any preceding claim, wherein the means for wirelessly communicating data from the sensor is configured to wirelessly communicate the measured impedance and/or capacitance.
12. The implantable sensor of any preceding claim, further comprising a memory for storing the measurements.
- 15 13. The implantable sensor of any preceding claim, further comprising processing means for processing the measured data.
- 20 14. The implantable sensor of any preceding claim, further comprising means for wirelessly receiving data from a remote transmitter.
15. The implantable sensor of any preceding claim, further comprising means for biasing the plurality of electrodes against the vessel wall.
- 25 16. The implantable sensor of any preceding claim, wherein the plurality of electrodes are anchorable to or within the vessel wall.
17. The implantable sensor of any preceding claim, wherein the plurality of electrodes comprises a circumferential array of electrodes.
- 30 18. The implantable sensor of any preceding claim, wherein the plurality of electrodes comprises a plurality of pairs of electrodes.

19. The implantable sensor of any preceding claim, further comprising a support structure with sufficient elasticity to collapse and expand with the vessel without constraining the vessel's natural physiological shape changes, on which the electrodes are mounted.
- 5 20. The implantable sensor of any preceding claim, further comprising a support structure having an anchored part configured to engage the vessel wall and wherein each electrode is coupled to the support structure by a connecting strut extending from the anchored part of the support structure, the connecting strut being configured to bias the electrode into engagement with the vessel wall.
- 10 21. The implantable sensor of claim 20, wherein at least one connecting strut is cantilevered from the anchored part of the support structure.
- 15 22. The implantable sensor of any of claims 20 or 21, wherein the support structure comprises a stent-like flexible, elastic, cylindrical structure comprised of a slotted tube, interconnecting struts, or mesh, and/or having a continuous zig-zag or sinusoidal geometry.
- 20 23. The implantable sensor of any of claims 20 to 22, wherein at least one strut comprises an anchor for engagement directly with a vessel wall.
- 25 24. The implantable sensor of any preceding claim, wherein at least part of the sensor is configured to endothelialize on a vessel wall.
- 30 25. The implantable sensor of any preceding claim, wherein at least one electrode has an anti-fouling surface to prevent endothelialization on a vessel wall.
26. The implantable sensor of claim 25, wherein the anti-fouling surface includes one or more material selected from carbon nanotubes, conductive polymers, hydrogels, conductive hydrogels, bioactive coatings, and a tissue engineered neural interface.
27. The implantable sensor of any preceding claim, wherein the implantable sensor is configured for untethered retention in a vessel.

28. The implantable sensor of any preceding claim, wherein the implantable sensor is configured for retention in a vessel following withdrawal of a deployment catheter.
- 5 29. The implantable sensor of any preceding claim, further comprising means for executing an algorithm to reduce effects of fouling and/or endothelialisation on electrode surfaces.
- 10 30. The implantable sensor of claim 29, wherein the algorithm includes one or more of the steps of performing impedance-to-distance calibration based on resting dimensions; salinity recalibration with scales impedance measurements with reference change; geometric reconstruction with elliptical assumption, fouling detection and rejection according to electrode geometry, preferably with data from three or more electrodes to reconstruct an ellipse, additional data used to detect and reject fouling.
- 15 31. The implantable sensor of any preceding claim, further comprising means for performing data correction with parallelogram edge and diagonal correction, by averaging opposed parallelogram sides.
- 20 32. The implantable sensor of any preceding claim, further comprising means for performing ellipse reconstruction to model a vessel shape, based on chordal lengths such as parallelogram side calculations.
- 25 33. The implantable sensor of any preceding claim, further comprising means for applying a correction to compensate for change from a round to elliptical cross-sectional shape of the vessel.
- 30 34. The implantable sensor of any preceding claim, further comprising means for comparing a parameter between multiple pairs of electrodes.
35. The implantable sensor of any preceding claim, further comprising means for determining a pair of electrodes which is most closely aligned with a selected axis of the vessel.
36. The implantable sensor of any preceding claim, adapted to determine vessel collapsibility or deformity over at least one respiratory cycle.

37. The implantable sensor of any preceding claim, further comprising at least one radiation-detectable marker and/or physical features to allow deployment with at least one pair of electrodes separated in an anterior-posterior dimension.
- 5 38. The implantable sensor of any preceding claim, wherein the means for providing a drive signal is configured to deliver a sinusoidal waveform and the sensor further comprises means for cycling through each electrode pair taking impedance measurements or capacitive measurements.
- 10 39. The implantable sensor of any preceding claim, further comprising means for performing an impedance to distance calibration based on initial resting dimensions of the electrodes, and to perform a geometric reconstruction based on the assumption that the blood vessel has an elliptical shape.
- 15 40. The implantable sensor of any of claims 1 to 16 wherein at least two electrodes are spaced apart in the longitudinal direction of the vessel.
41. The implantable sensor of claim 40, further comprising means for processing data from the electrodes on the basis of impedance planimetry.
- 20 42. The implantable sensor of claim 40, further comprising means for applying an alternating current, AC, across an outer pair of the plurality of electrodes.
43. The implantable sensor of claim 40, further comprising means for measuring AC voltage  
25 between an inner pair of the plurality of electrodes, the inner pair positioned between the outer pair of electrodes.
44. A blood vessel monitoring system comprising at least one implantable sensor of any preceding claim, and a remote processor configured to receive the communicated data and  
30 calculate distance between the electrodes based on the measured impedance or the measured capacitance.

45. The blood vessel monitoring system of claim 44, wherein the remote processor is further configured to estimate vessel diameter based on measurements of impedance and capacitance between at least two of the plurality of electrodes.
- 5 46. The blood vessel monitoring system of claim 44, wherein the remote processor is further configured to determine cross-sectional area at a mid-point between said electrodes.
47. The blood vessel monitoring system of claim 44, wherein the remote processor is further configured to select a pair of electrodes from the plurality of electrodes to which drive  
10 signals are to be delivered.
48. The blood vessel monitoring system of claim 44, wherein the remote processor is further configured to estimate blood velocity from the calculated distance between the electrodes.
- 15 49. The blood vessel monitoring system of claim 44, wherein the remote processor is further configured to estimate a pressure gradient from the calculated distance between the electrodes.
50. A blood vessel monitoring system comprising:
- 20 a plurality of implantable electromagnetic beacon transponders for placement in a blood vessel, on, adjacent or in a blood vessel wall, the transponders adapted to emit a signal when excited;
- an electromagnetic source for exciting the transponders; and
- a sensing array to receive emitted signals and monitor relative positions of the  
25 implanted transponders.
51. The blood vessel monitoring system of claim 50, wherein the sensor array is configured to detect a resonant frequency of each transponder to differentiate the transponders.
- 30 52. The blood vessel monitoring system of any of claims 50 to 51, further comprising means for determining a cross sectional area of the vessel.

53. The blood vessel monitoring system of any of claims 50 to 52, further comprising means for determining the blood vessel diameter based on the relative positions of the implanted transponders.
- 5 54. An implantable sensor for implantation in a vessel, comprising:  
a plurality of electromagnetic beacon transponders for placement on, adjacent or in a vessel wall, the electromagnetic beacon transponders adapted to emit a signal when excited by electromagnetic radiation.
- 10 55. The implantable sensor of claim 54 further comprising a battery power source.
56. The implantable sensor of claim 54 further comprising a data processing subsystem.
57. The implantable sensor of claim 54 further comprising a communications subsystem.
- 15 58. A vascular monitoring method comprising  
implanting a plurality of electrodes within a vessel, on, in or adjacent a vessel wall;  
providing a drive signal to the electrodes;  
measuring at least one of impedance and capacitance between at least two of the plurality  
20 of electrodes; and  
wirelessly communicating data from within the vessel.
59. The method of claim 58, further comprising calculating the distance between the electrodes based on the measured impedance or the measured capacitance.
- 25 60. The method of claim 58 or 59, further comprising estimating vessel diameter based on measurements of impedance or capacitance between at least two of the plurality of electrodes.
- 30 61. The method of any of claims 58 to 60 further comprising determining cross-sectional area of the vessel's lumen based on said impedance or capacitance.
62. The method of any of claims 58 to 61, further comprising selecting a pair of electrodes from the plurality of electrodes and delivering drive signals to the selected pair.

63. The method of any of claims 59 to 62, further comprising estimating blood velocity from the calculated distance between the electrodes.
- 5 64. The method of any of claims 59 to 63, further comprising estimating a pressure gradient from the calculated distance between the electrodes.
65. The method of any of claims 58 to 64, further comprising maintaining at least one reference electrode at a fixed distance from one of the electrodes and measuring at least  
10 one of impedance or capacitance between said electrode and said reference electrode.
66. The method of any of claims 58 to 65, further comprising calibrating measurements between the plurality of electrodes using a measurement of impedance or capacitance between said electrode and said reference electrode.  
15
67. The method of any of claims 58 to 66, further comprising processing the measured electrical parameter to monitor variations in the conductivity of the intervening media and to apply a correction factor accordingly.
- 20 68. The method of any of claims 58 to 67, further comprising wirelessly communicating the measured impedance and/or capacitance.
69. The method of any of claims 58 to 68, further comprising storing the measurements.
- 25 70. The method of any of claims 58 to 69, further comprising processing the measured data.
71. The method of any of claims 58 to 70, further comprising wirelessly receiving data from a remote transmitter.
- 30 72. The method of any of claims 58 to 71, further comprising executing an algorithm to correct the measurements for effects of fouling and/or endothelialisation on electrode surfaces.

73. The method of claim 72, wherein executing the algorithm includes one or more of the steps of performing impedance-to-distance calibration based on resting dimensions; salinity recalibration with scales impedance measurements with reference change; geometric reconstruction with elliptical assumption, fouling detection and rejection according to electrode geometry, preferably with data from three or more electrodes to reconstruct an ellipse, additional data used to detect and reject fouling.
74. The method of any of claims 58 to 73, further comprising performing data correction with parallelogram edge and diagonal correction, by averaging opposed parallelogram sides.
75. The method of any of claims 58 to 74, further comprising performing ellipse reconstruction to model a vessel shape, based on chordal lengths such as parallelogram side calculations.
76. The method of any of claims 58 to 75, further comprising applying a correction to compensate for change from a round to elliptical cross-sectional shape of the vessel.
77. The method of any of claims 58 to 76, further comprising comparing a parameter between multiple pairs of electrodes.
78. The method of any of claims 58 to 77, further comprising determining a pair of electrodes which is most closely aligned with a selected axis of the vessel.
79. The method of any of claims 58 to 78, further comprising determining vessel collapsibility or deformity over at least one respiratory cycle.
80. The method of any of claims 58 to 79, further comprising delivering a sinusoidal waveform and cycling through each electrode pair taking impedance measurements or capacitive measurements.
81. The method of any of claims 58 to 80, further comprising performing an impedance to distance calibration based on initial resting dimensions of the electrodes, and performing a geometric reconstruction based on the assumption that the blood vessel has an elliptical shape.

82. The method of any of claims 58 to 81, further comprising processing data from the electrodes on the basis of impedance planimetry.
- 5 83. The method of any of claims 58 to 82, further comprising applying an alternating current, AC, across an outer pair of the plurality of electrodes.
84. The method of any of claims 58 to 83, further comprising measuring AC voltage between an inner pair of the plurality of electrodes, the inner pair positioned between the outer pair  
10 of electrodes.
85. A blood vessel monitoring method comprising:
- implanting a plurality of implantable electromagnetic beacon transponders in a blood vessel, on, adjacent or in a blood vessel wall, the transponders adapted to emit a  
15 signal when excited;
- exciting the transponders; and
- receiving emitted signals and monitoring relative positions of the implanted transponders.
- 20 86. The method of claim 85, further comprising detecting a resonant frequency of each transponder to differentiate the transponders.
87. The method of claim 85 or 86, further comprising determining a cross sectional area of the vessel.
- 25 88. The method of any of claims 85 to 87, further comprising determining the blood vessel diameter based on the relative positions of the implanted transponders.
- 30

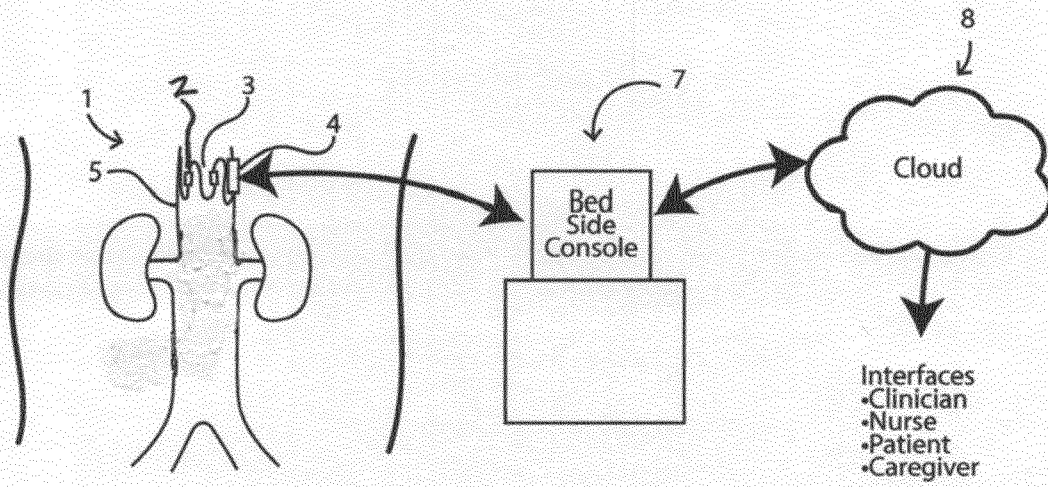

Fig.1

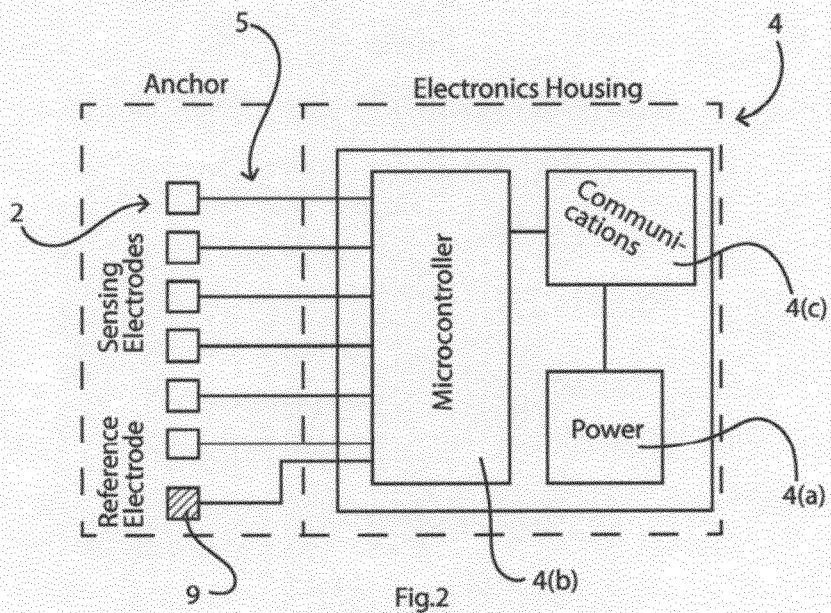

Fig.2

2/14

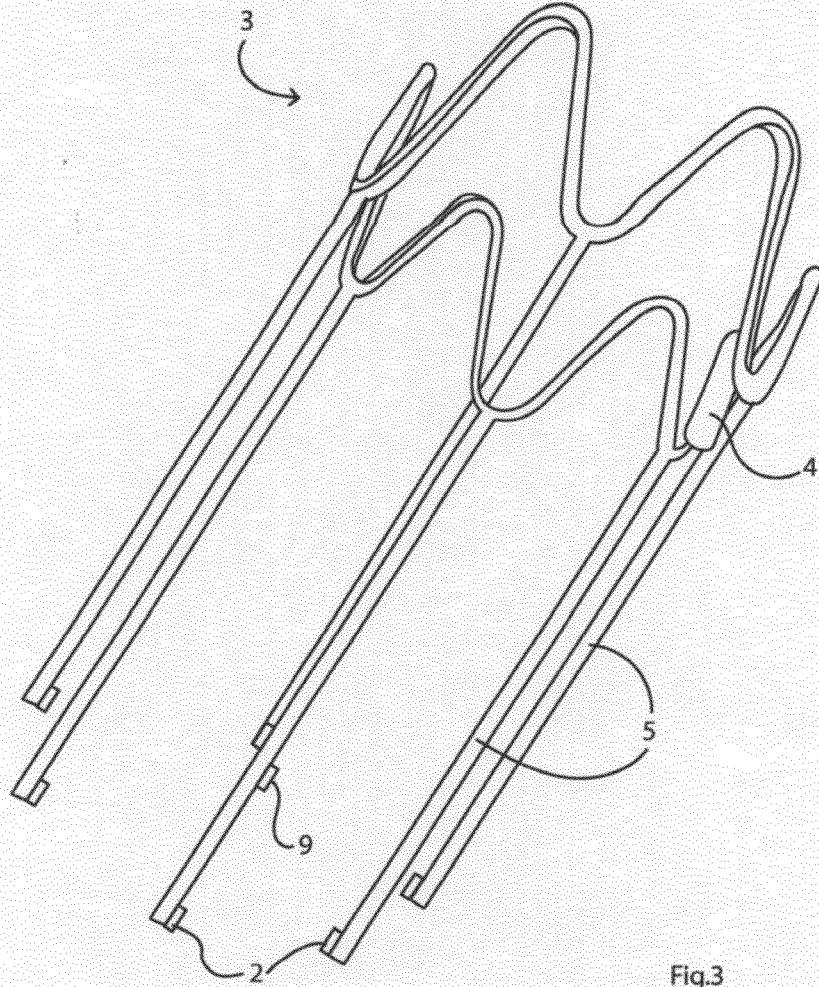

Fig.3

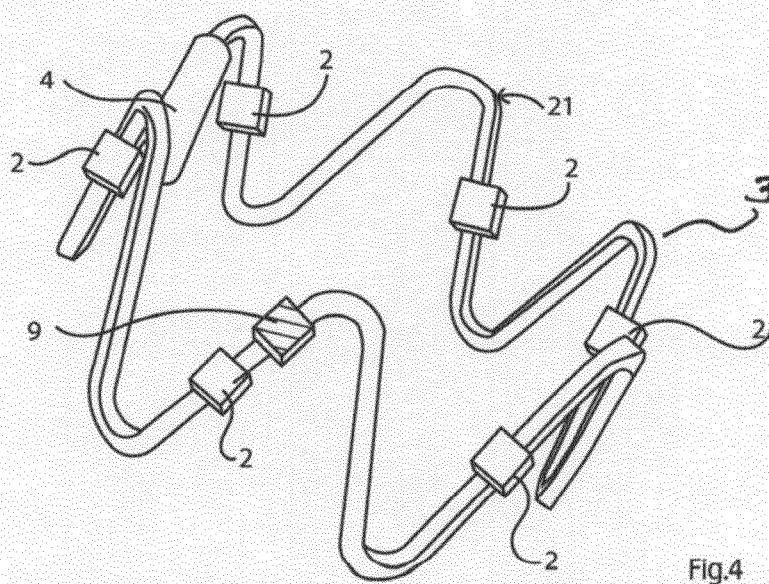

Fig.4

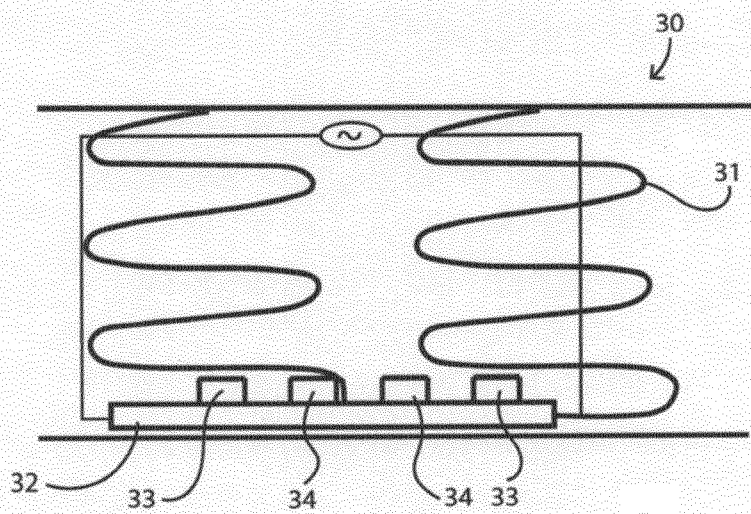
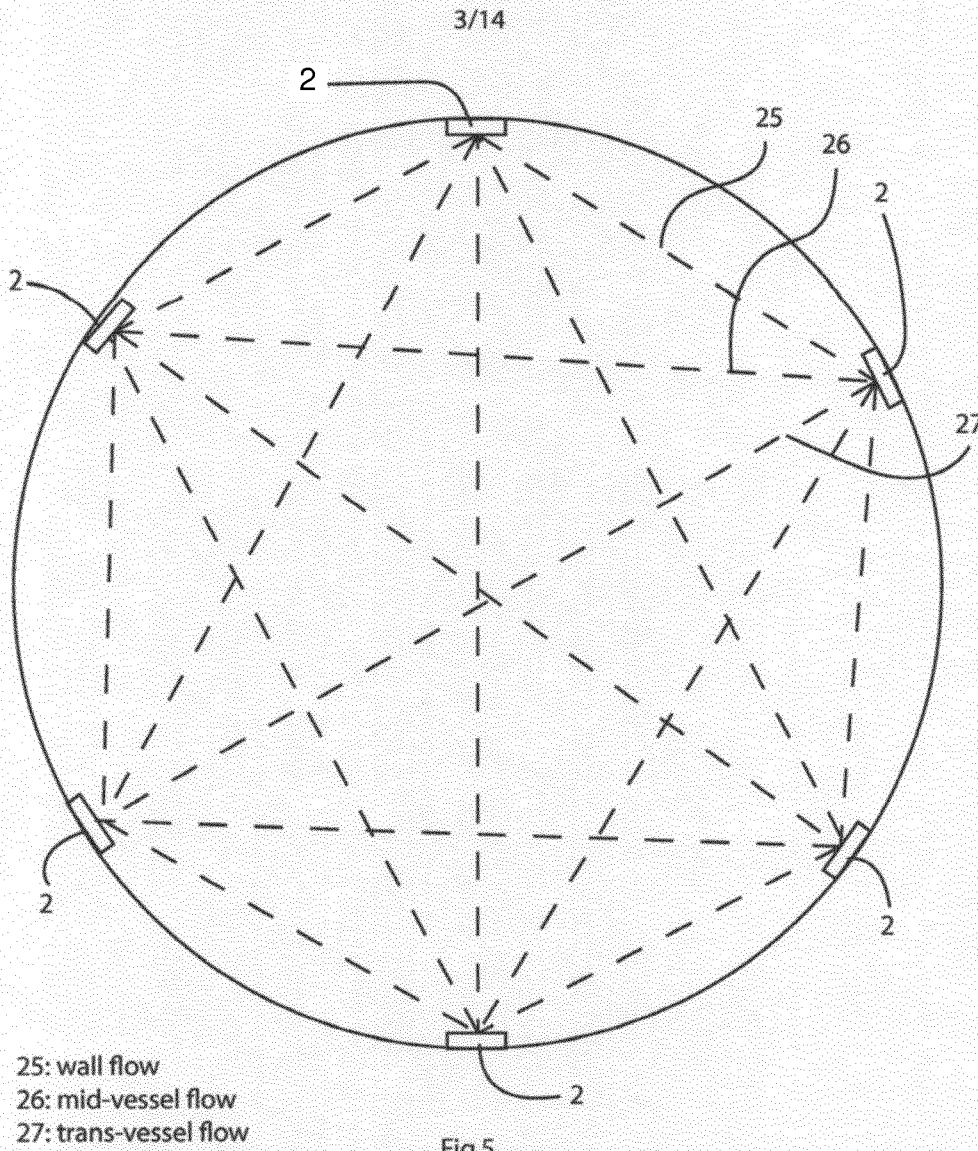

Fig.6

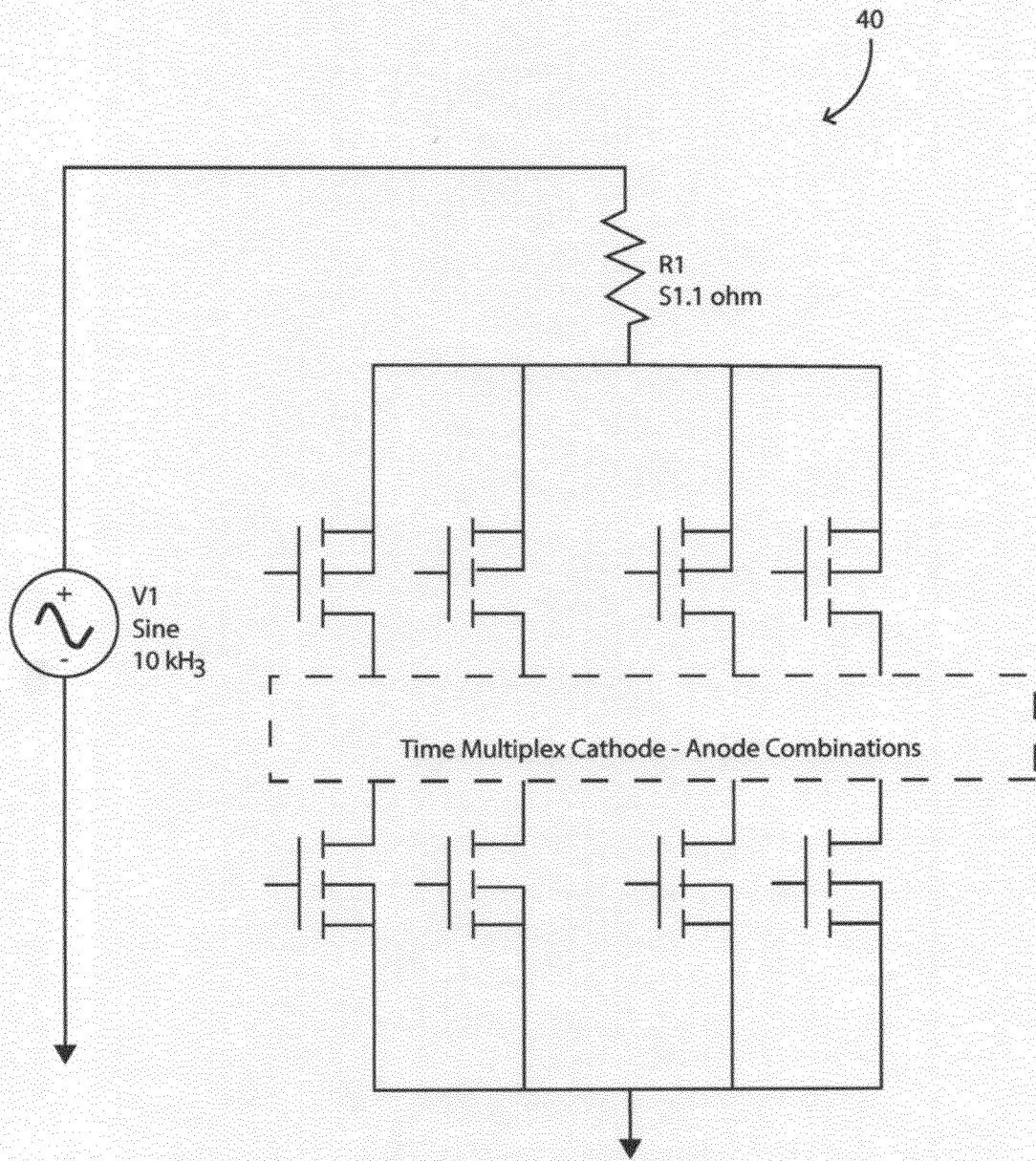

Fig.7

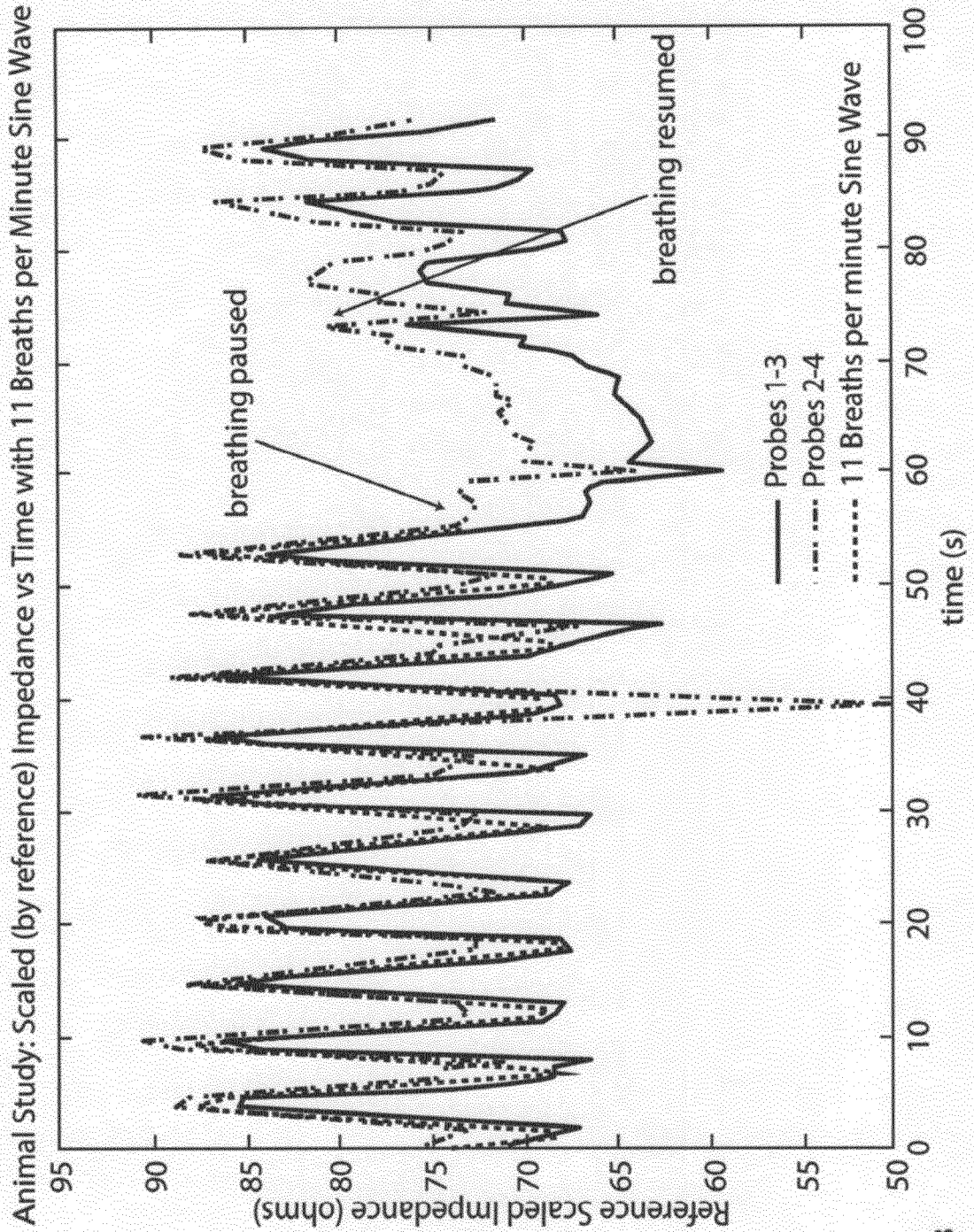

Fig.8

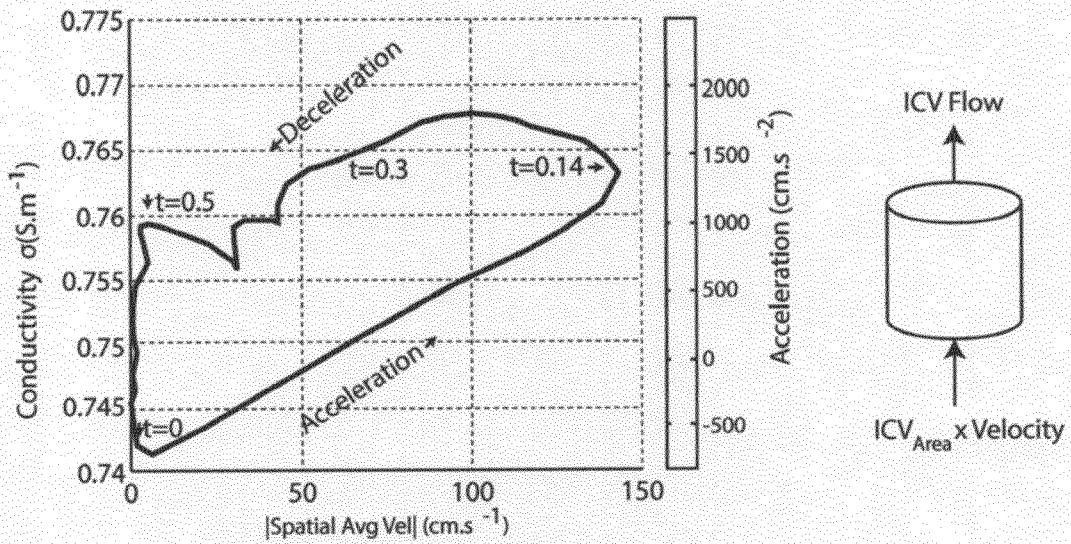

Fig.9

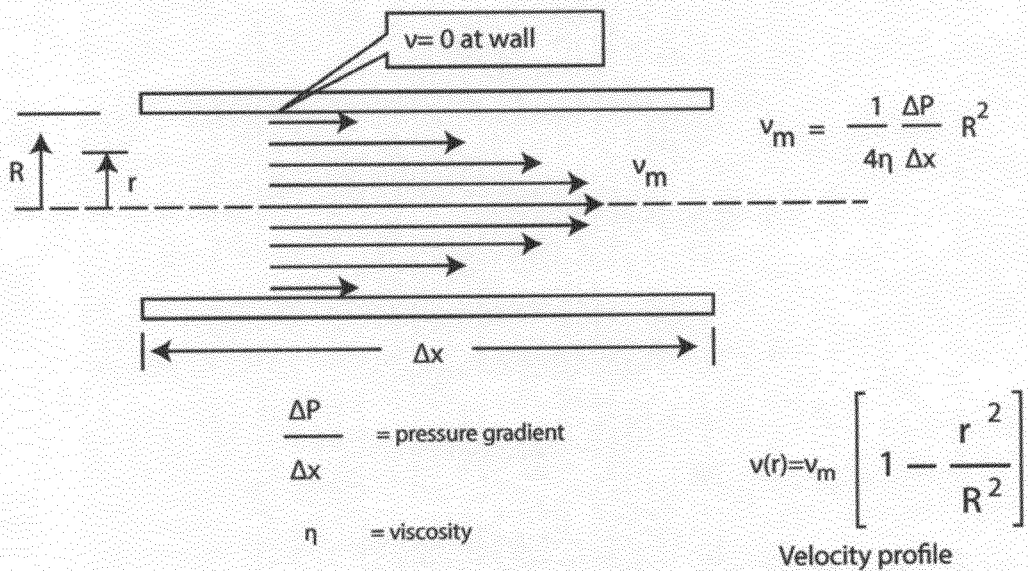

Fig.10

7/14

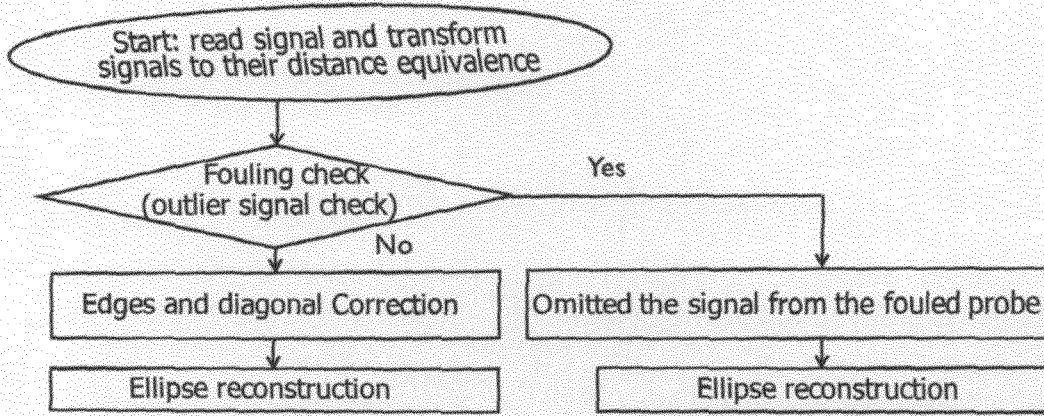
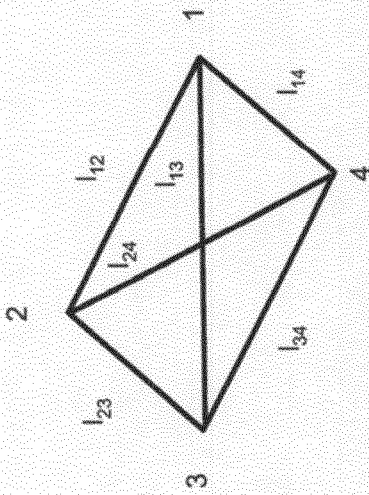

Fig.11

1 Measured Data (parallelogram)



3 Parallelogram Edge Correction

$$a = (l_{12} + l_{34}) / 2$$

$$b = (l_{23} + l_{41}) / 2$$

2 Expected Correction (parallelogram)

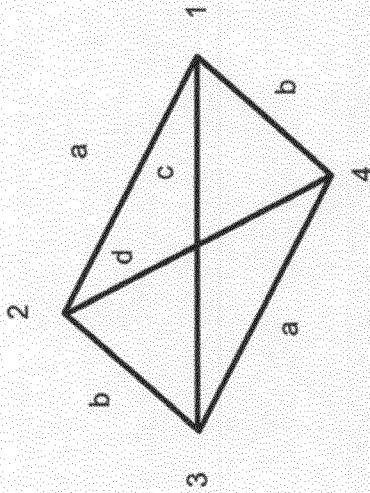

4 Parallelogram Diagonal Correction

$$c = l_{13} + x, d = l_{24} + y$$

(x, y here are the correction terms)

The correction is reduced to an optimization problem:  $\min x^2 + y^2$

$$\text{S. t. } (l_{13} + x)^2 + (l_{24} + y)^2 = 2(a^2 + b^2)$$

(Geometric constraint for Parallelogram)

Solving the optimization problem above:

$$c = 2l_{13}^2 (a^2 + b^2) / (l_{13}^2 + l_{24}^2)$$

$$d = 2l_{24}^2 (a^2 + b^2) / (l_{13}^2 + l_{24}^2)$$

Fig.12

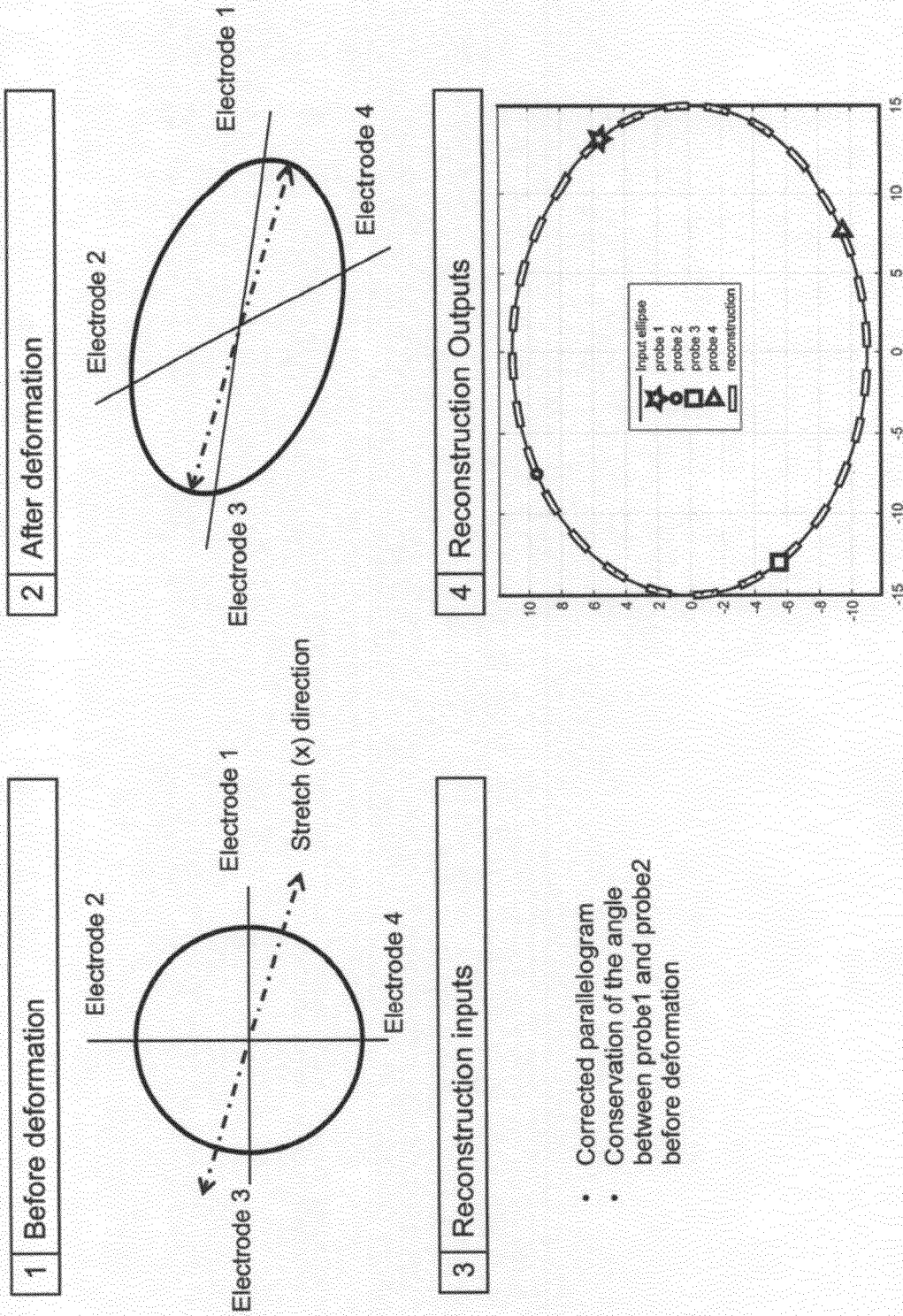

- Corrected parallelogram
- Conservation of the angle between probe1 and probe2 before deformation

Fig.13

2 Fouling Rejection

1 Noise Rejection

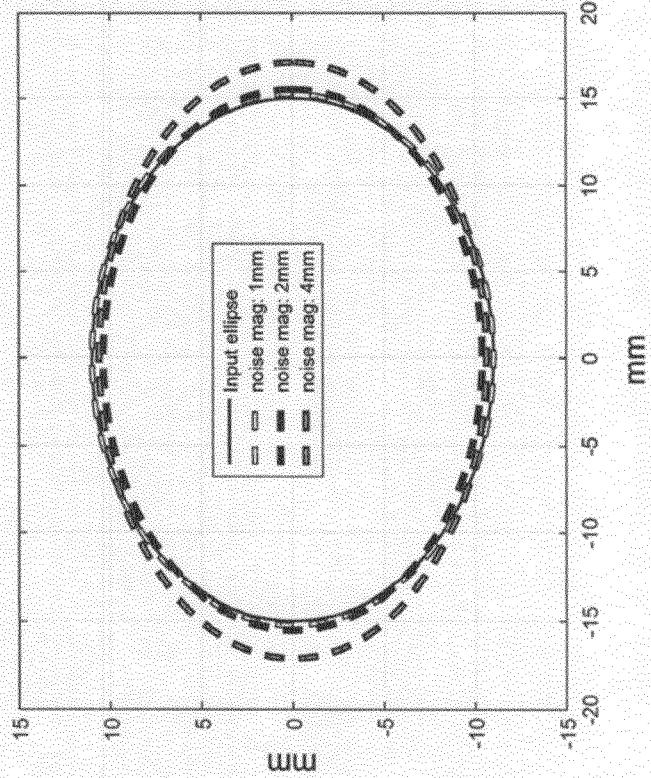
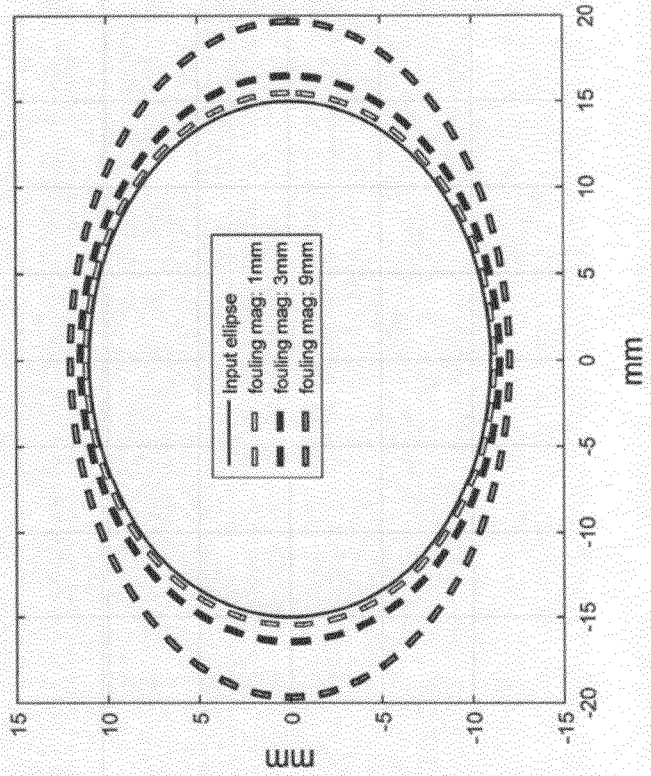

Fig.14

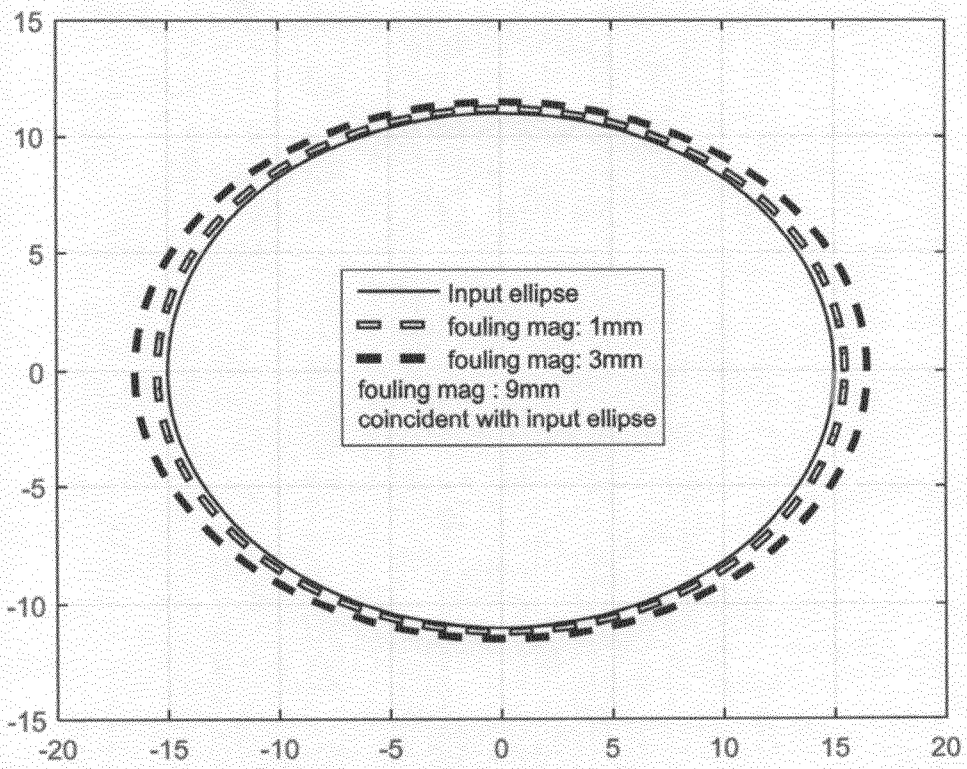
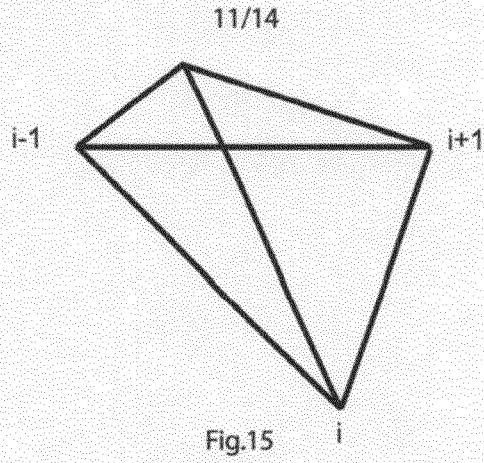

Fig.16

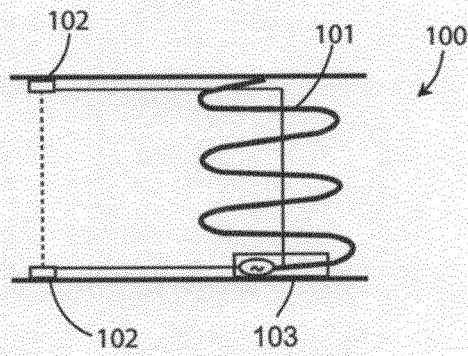

Fig.17

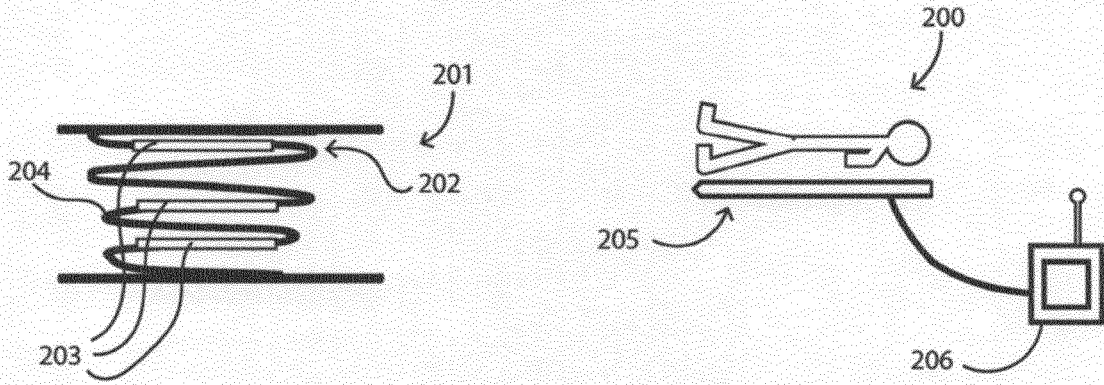

Fig.18

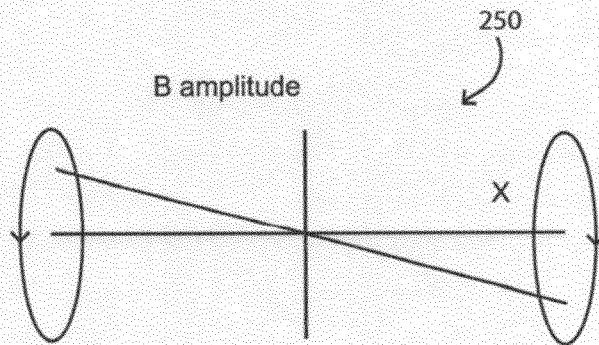

Fig.19

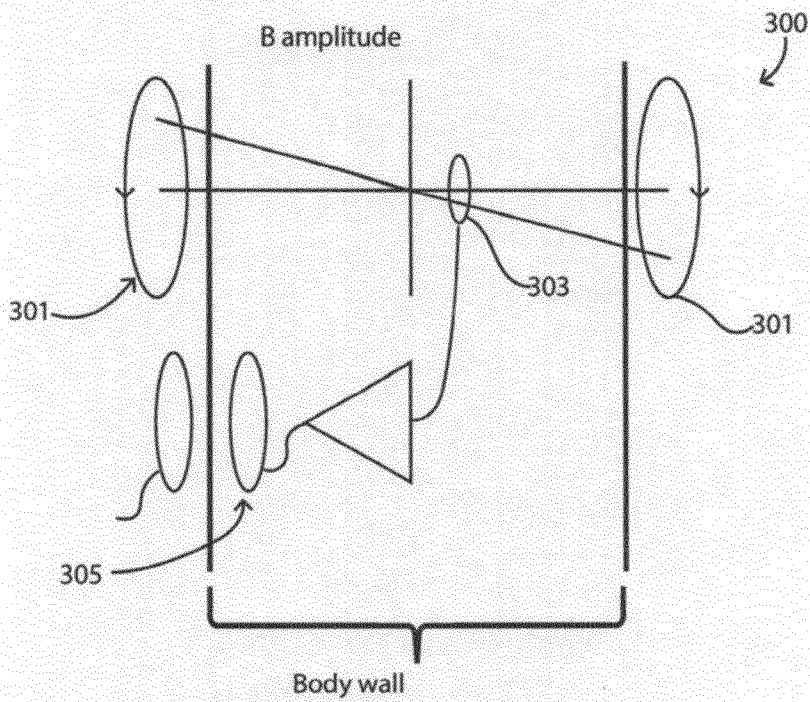

Fig.20

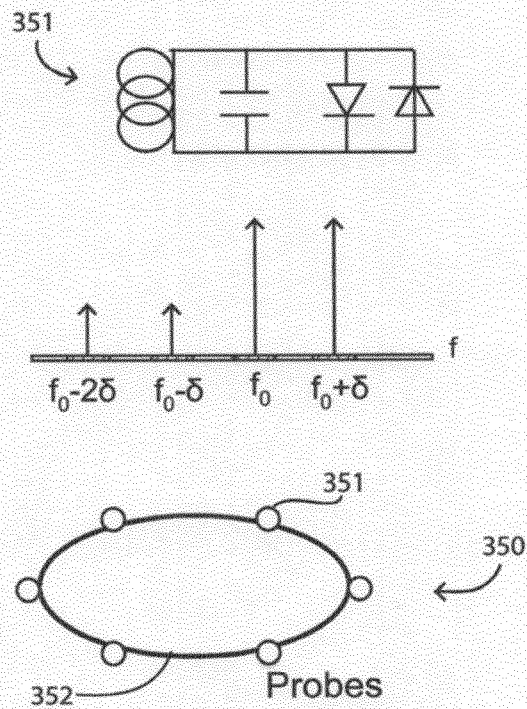

Fig.21

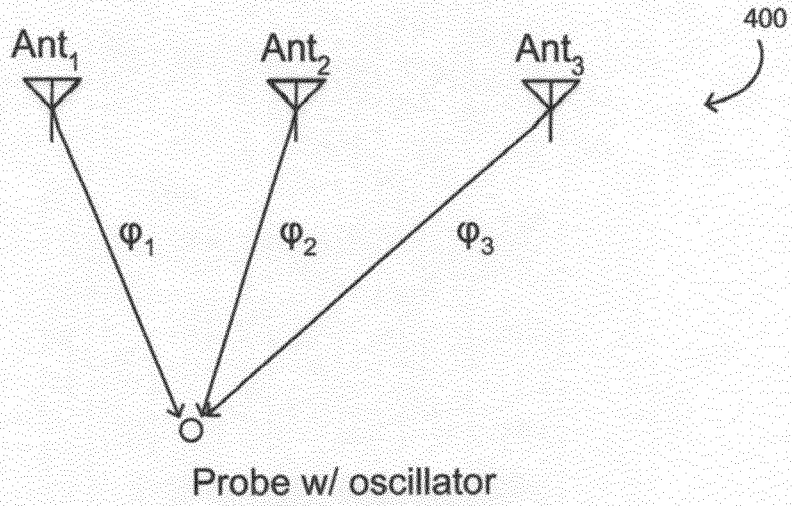

Fig.22

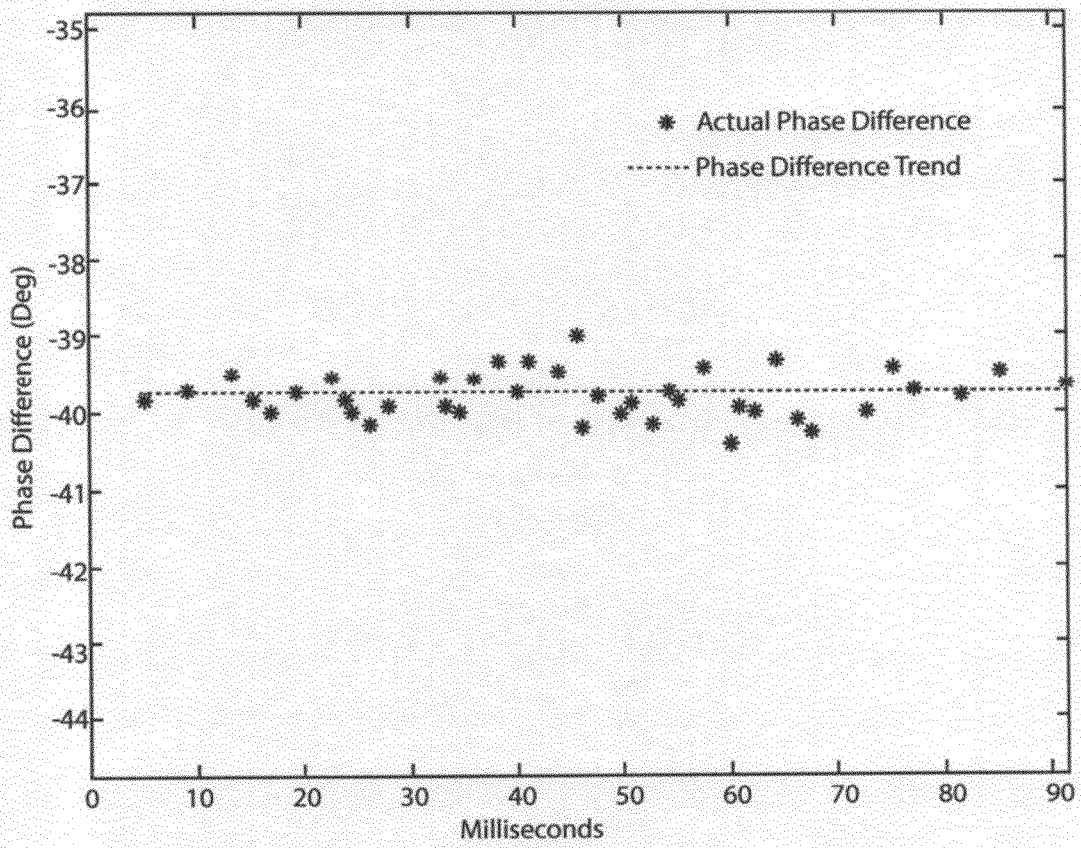

Fig.23

INTERNATIONAL SEARCH REPORT

International application No  
PCT/EP2018/064386

A. CLASSIFICATION OF SUBJECT MATTER  
INV. A61B5/107 A61B5/00 A61B5/053  
ADD.  
According to International Patent Classification (IPC) or to both national classification and IPC

B. FIELDS SEARCHED  
Minimum documentation searched (classification system followed by classification symbols)  
A61B

Documentation searched other than minimum documentation to the extent that such documents are included in the fields searched

Electronic data base consulted during the international search (name of data base and, where practicable, search terms used)  
EPO-Internal, WPI Data

C. DOCUMENTS CONSIDERED TO BE RELEVANT

Category*	Citation of document, with indication, where appropriate, of the relevant passages	Relevant to claim No.
X	WO 2007/028035 A2 (PROTEUS BIOMEDICAL INC [US]; ZDEBLICK MARK [US]; ROBERTSON TIMOTHY [US] 8 March 2007 (2007-03-08) figures 1, 19, 23 page 48, line 16 - page 49, line 14 -----	1-57
X	US 2003/158584 A1 (CATES ADAM W [US] ET AL) 21 August 2003 (2003-08-21) figure 20 paragraphs [0143], [0144], [0159] -----	1-57
X	US 2013/041244 A1 (WOIAS PETER [DE] ET AL) 14 February 2013 (2013-02-14) paragraphs [0011], [0026], [0028] - [0030] -----	1-57

Further documents are listed in the continuation of Box C.

See patent family annex.

\* Special categories of cited documents :

"A" document defining the general state of the art which is not considered to be of particular relevance	"T" later document published after the international filing date or priority date and not in conflict with the application but cited to understand the principle or theory underlying the invention
"E" earlier application or patent but published on or after the international filing date	"X" document of particular relevance; the claimed invention cannot be considered novel or cannot be considered to involve an inventive step when the document is taken alone
"L" document which may throw doubts on priority claim(s) or which is cited to establish the publication date of another citation or other special reason (as specified)	"Y" document of particular relevance; the claimed invention cannot be considered to involve an inventive step when the document is combined with one or more other such documents, such combination being obvious to a person skilled in the art
"O" document referring to an oral disclosure, use, exhibition or other means	"&" document member of the same patent family
"P" document published prior to the international filing date but later than the priority date claimed	

Date of the actual completion of the international search <b>17 August 2018</b>	Date of mailing of the international search report <b>29/08/2018</b>
--	---

Name and mailing address of the ISA/ European Patent Office, P.B. 5818 Patentlaan 2 NL - 2280 HV Rijswijk Tel. (+31-70) 340-2040, Fax: (+31-70) 340-3016	Authorized officer <b>Brendemühl, S</b>
--	--

# INTERNATIONAL SEARCH REPORT

International application No.  
PCT/EP2018/064386

## Box No. II Observations where certain claims were found unsearchable (Continuation of item 2 of first sheet)

This international search report has not been established in respect of certain claims under Article 17(2)(a) for the following reasons:

1.  Claims Nos.: **58-88**  
because they relate to subject matter not required to be searched by this Authority, namely:  
**see FURTHER INFORMATION sheet PCT/ISA/210**
  
2.  Claims Nos.:  
because they relate to parts of the international application that do not comply with the prescribed requirements to such an extent that no meaningful international search can be carried out, specifically:
  
3.  Claims Nos.:  
because they are dependent claims and are not drafted in accordance with the second and third sentences of Rule 6.4(a).

## Box No. III Observations where unity of invention is lacking (Continuation of item 3 of first sheet)

This International Searching Authority found multiple inventions in this international application, as follows:

1.  As all required additional search fees were timely paid by the applicant, this international search report covers all searchable claims.
  
2.  As all searchable claims could be searched without effort justifying an additional fees, this Authority did not invite payment of additional fees.
  
3.  As only some of the required additional search fees were timely paid by the applicant, this international search report covers only those claims for which fees were paid, specifically claims Nos.:
  
4.  No required additional search fees were timely paid by the applicant. Consequently, this international search report is restricted to the invention first mentioned in the claims; it is covered by claims Nos.:

### Remark on Protest

- The additional search fees were accompanied by the applicant's protest and, where applicable, the payment of a protest fee.
- The additional search fees were accompanied by the applicant's protest but the applicable protest fee was not paid within the time limit specified in the invitation.
- No protest accompanied the payment of additional search fees.

**FURTHER INFORMATION CONTINUED FROM PCT/ISA/ 210**

Continuation of Box II.1

Claims Nos.: 58-88

Claims 58-88 relate to a method for treatment of the human or animal body by surgery, contrary to Rule 39.1(iv) PCT. Independent claim 58 discloses "A vascular monitoring method comprising implanting a plurality of electrodes within a vessel". Implanting electrodes in a (vascular) vessel is considered to be surgery. Independent claim 85 discloses "A blood vessel monitoring method comprising implanting a plurality of implantable electromagnetic beacon transponders in a blood vessel". Implanting transponders in a blood vessel is considered to be surgery. Claims 59-84 and 86-88 depend on one of the independent claims 58 or 85. They thus also disclose the surgical method step and therefore also relate to a surgical method.

# INTERNATIONAL SEARCH REPORT

Information on patent family members

International application No PCT/EP2018/064386
---

Patent document cited in search report	Publication date	Patent family member(s)	Publication date	
WO 2007028035	A2	08-03-2007	EP 1920418 A2	14-05-2008
			JP 5714210 B2	07-05-2015
			JP 2009506838 A	19-02-2009
			JP 2014176753 A	25-09-2014
			JP 2016144696 A	12-08-2016
			US 2008306359 A1	11-12-2008
			US 2014051965 A1	20-02-2014
			WO 2007028035 A2	08-03-2007
-----				
US 2003158584	A1	21-08-2003	NONE	
-----				
US 2013041244	A1	14-02-2013	DE 102010010348 A1	08-09-2011
			EP 2542149 A1	09-01-2013
			US 2013041244 A1	14-02-2013
			WO 2011107247 A1	09-09-2011
-----				

专利名称(译)	用于血管监视的可植入传感器		
公开(公告)号	<a href="#">EP3629921A1</a>	公开(公告)日	2020-04-08
申请号	EP2018728627	申请日	2018-05-31
申请(专利权)人(译)	FOUNDRY创新及研究1. , LTD.		
当前申请(专利权)人(译)	FOUNDRY创新及研究1. , LTD.		
[标]发明人	SUTTON DOUGLAS S GIFFORD III HANSON S SWEENEY FIACHRA M WILFLEY BRIAN MCKENNA EDWARD ZHOU XUANCE CALLAS PETER		
发明人	SUTTON, DOUGLAS S. GIFFORD III, HANSON S. SWEENEY, FIACHRA M. WILFLEY, BRIAN MCKENNA, EDWARD ZHOU, XUANCE CALLAS, PETER FAN, DANYANG		
IPC分类号	A61B5/107 A61B5/00 A61B5/053		
CPC分类号	A61B5/0538 A61B5/1076 A61B5/6876 A61B5/6862 A61B5/6886		
代理机构(译)	TOMKINS & CO.		
优先权	62/512992 2017-05-31 US		
外部链接	<a href="#">Espacenet</a>		

#### 摘要(译)

一种用于植入血管中的可植入传感器，包括：多个电极，用于放置在血管壁上，血管壁中或血管壁附近；向电极提供驱动信号的装置；用于测量至少两个电极之间的阻抗和电容中的至少一个的装置。多个电极，以及用于无线传输来自传感器的数据的装置以及包括该电极的血管监测系统。