

(19) World Intellectual Property Organization  
International Bureau



(43) International Publication Date  
9 September 2005 (09.09.2005)

PCT

(10) International Publication Number  
WO 2005/083940 A1

- (51) International Patent Classification<sup>7</sup>: **H04L 12/28**
- (21) International Application Number:  
PCT/IB2005/050427
- (22) International Filing Date: 1 February 2005 (01.02.2005)
- (25) Filing Language: English
- (26) Publication Language: English
- (30) Priority Data:  
60/545,819 19 February 2004 (19.02.2004) US
- (71) Applicant (for all designated States except US): **KONINKLIJKE PHILIPS ELECTRONICS, N.V.** [NL/NL]; Groenewoudseweg 1, NL-5621 BA Eindhoven (NL).
- (72) Inventors; and
- (75) Inventors/Applicants (for US only): **WITTENBER, Jan** [US/US]; 595 Miner Road, Cleveland, OH 44143 (US). **BARGA, John** [US/US]; 595 Miner Road, Cleveland, OH 44143 (US). **ROSNOV, Brian, S.** [US/US]; 595 Miner Road, Cleveland, OH 44143 (US). **KOSCHEK, Andrew, G.** [US/US]; 595 Miner Road, Cleveland, OH 44143 (US).
- (74) Common Representative: **KONINKLIJKE PHILIPS ELECTRONICS, N.V.**; c/o LUNDIN, Thomas, M., 595 Miner Road, Cleveland, OH 44143 (US).

- (81) Designated States (unless otherwise indicated, for every kind of national protection available): AE, AG, AL, AM, AT, AU, AZ, BA, BB, BG, BR, BW, BY, BZ, CA, CH, CN, CO, CR, CU, CZ, DE, DK, DM, DZ, EC, EE, EG, ES, FI, GB, GD, GE, GH, GM, HR, HU, ID, IL, IN, IS, JP, KE, KG, KP, KR, KZ, LC, LK, LR, LS, LT, LU, LV, MA, MD, MG, MK, MN, MW, MX, MZ, NA, NI, NO, NZ, OM, PG, PH, PL, PT, RO, RU, SC, SD, SE, SG, SK, SL, SM, SY, TJ, TM, TN, TR, TT, TZ, UA, UG, US, UZ, VC, VN, YU, ZA, ZM, ZW.
- (84) Designated States (unless otherwise indicated, for every kind of regional protection available): ARIPO (BW, GH, GM, KE, LS, MW, MZ, NA, SD, SL, SZ, TZ, UG, ZM, ZW), Eurasian (AM, AZ, BY, KG, KZ, MD, RU, TJ, TM), European (AT, BE, BG, CH, CY, CZ, DE, DK, EE, ES, FI, FR, GB, GR, HU, IE, IS, IT, LT, LU, MC, NL, PL, PT, RO, SE, SI, SK, TR), OAPI (BF, BJ, CF, CG, CI, CM, GA, GN, GQ, GW, ML, MR, NE, SN, TD, TG).

**Declaration under Rule 4.17:**

— as to applicant's entitlement to apply for and be granted a patent (Rule 4.17(ii)) for the following designations AE, AG, AL, AM, AT, AU, AZ, BA, BB, BG, BR, BW, BY, BZ, CA, CH, CN, CO, CR, CU, CZ, DE, DK, DM, DZ, EC, EE, EG, ES, FI, GB, GD, GE, GH, GM, HR, HU, ID, IL, IN, IS,

[Continued on next page]

(54) Title: METHOD AND ASSOCIATED SYSTEM FOR WIRELESS MEDICAL MONITORING AND PATIENT MONITORING DEVICE

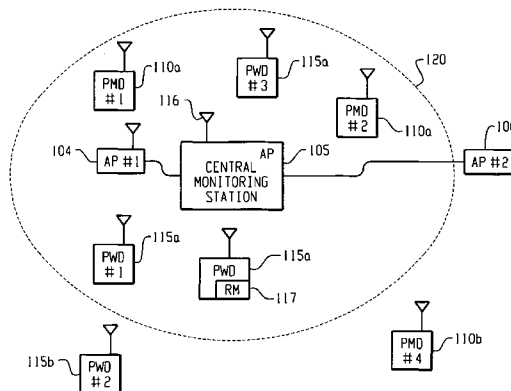

(57) Abstract: A method for paging/finding a wireless patient-monitoring device in a WLAN network includes the steps of determining the status of a radio module (RM) (117) of one or more wireless monitoring devices comprising one of a Patient-Wearable Device (PWD) (115a, 115b) and a Patient-Monitoring Device (PMD) (110a, 110b) that are adapted for dual-communication with one of or more Access Points (104, 106) and a central-monitoring station in a WLAN. The overall status of the PWD/PMD can be a plurality of meta-states including standby, inactive, active, sleep. After the status is determined, there is a selection of a particular PWD/PMD for receipt of wireless transmission of a signal that is adapted for changing a meta-state of the device to a desired state if the current state of the particular wireless monitoring device is not the desired state. An aural-code function of the particular wireless monitoring device is activated by transmitting an instructional signal to the particular wireless patient-monitoring device to emit a predetermined first aural-code that can be heard at least by a patient being monitored by the particular PWD/PMD, so that the patient is instructed to contact the nurse's station. Alternatively, or in addition thereto, a second aural tone may be broadcast that is emitted at a volume loud enough to permit a clinic or facility personnel to walk around and locate the device by the sound.

WO 2005/083940 A1



*JP, KE, KG, KP, KR, KZ, LC, LK, LR, LS, LT, LU, LV, MA, MD, MG, MK, MN, MW, MX, MZ, NA, NI, NO, NZ, OM, PG, PH, PL, PT, RO, RU, SC, SD, SE, SG, SK, SL, SM, SY, TJ, TM, TN, TR, TT, TZ, UA, UG, UZ, VC, VN, YU, ZA, ZM, ZW, ARIPO patent (BW, GH, GM, KE, LS, MW, MZ, NA, SD, SL, SZ, TZ, UG, ZM, ZW), Eurasian patent (AM, AZ, BY, KG, KZ, MD, RU, TJ, TM), European patent (AT, BE, BG, CH, CY, CZ, DE, DK, EE, ES, FI, FR, GB, GR, HU, IE, IS, IT, LT, LU, MC, NL, PL, PT, RO, SE, SI, SK, TR), OAPI patent (BF, BJ, CF, CG, CI, CM, GA, GN, GQ, GW, ML, MR, NE, SN, TD, TG)*

**Published:**

— *with international search report*

*For two-letter codes and other abbreviations, refer to the "Guidance Notes on Codes and Abbreviations" appearing at the beginning of each regular issue of the PCT Gazette.*

METHOD AND ASSOCIATED SYSTEM FOR WIRELESS MEDICAL MONITORING AND PATIENT MONITORING DEVICE

### DESCRIPTION

The present invention relates to data communications protocol used for wireless medical telemetry systems (WMTS) device management. More particularly, the present invention relates to the functional management of Internet and DECT-based protocols.

Digital Enhanced Cordless Telecommunication (DECT), which originated as a European initiative, has become popular around the world to provide efficient access to many different types of applications and services. DECT based systems are becoming increasingly popular, particularly in the field of wireless medical telemetry systems, with Patient-Wearable Devices (PWD) that are capable of monitoring, for example, patient vital signs, and reporting wirelessly to a host or monitoring station.

Preserving battery power is a desirable goal, and of all the operational functions of the PWD, the wireless transmission function utilizes the most power. Thus, such devices can be engineered with sleep modes, where the devices do not have to be fully powered up and receive a wakeup signal to become fully activated. Ideally, a range of low-power states above that of a sleep mode would be desirable so that a patient wearing a PWD could quickly contact a member of the nursing staff or a misplaced device could be easily located.

However, present generation telemetry infrastructures are not capable of advanced functions regarding reduced power modes. The present state of the art "TeleVision" technology provides only unidirectional "simplex" capability (i.e. from the device to a central site) and the infrastructures lack the AP proxy functions and/or wireless bidirectional capability, as well as a built-in control protocol or associated application meta-state machine model.

25

The present invention provides a data communications protocol that enables several medical device management functions using specialized Internet and DECT-based protocols. In particular, the present invention permits a wireless medical device in a very low power state to resume normal operation after being paged from a "standby" mode, and/or by emitting audial indications if not resuming normal operation, based on its persistent meta-state.

One way the present invention can function is that an Internet control directs the Access Point (AP) in a wireless network to issue a DECT "call" to the wireless medical device. Upon receipt of the DECT call, the device either resumes normal operation from standby mode or makes audial indications that facilitate clinicians to find the device in the event such device was "misplaced" and/or lost. It is a common occurrence in busy clinical settings that wireless medical devices can become misplaced, thus detracting from the ability of clinicians to render direct patient care.

In addition, another aspect of the present invention is that clinicians are enabled to prompt the patients having ambulatory medical telemetry devices so as to immediately contact the nursing staff (directly or by pressing a button on the patient-worn device).

The present invention also automates and increases the range and the scale (in terms of the number of devices concurrently managed) in ambulatory and portable device standby-mode management applications through the use of bidirectional, wireless data communication technology, thereby enabling clinicians to remotely control these operations rather than spending time traversing between the device and the nurse's station or spending time and energy unproductively (relative to rendering direct patient medical care) finding devices or patients.

Fig. 1 is an illustration of a system according to the presently claimed invention.

Fig. 2A is an illustration of some of the meta-states that can be used to classify the status of a patient medical device according to the presently claimed invention.

Fig. 2B shows how the meta-states change during typical transitions of a device as it moves through a standby-resume “life-cycle.”

Fig. 3 is a detailed view of some the components that comprise a patient wearable device/patient-monitoring device according to the present invention.

5

It is to be understood that the following descriptions, which are presented in conjunction with the drawings, are provided for purposes of illustration, not for limitation. A person of ordinary skill in the art will appreciate that there are many variations of the present invention that lie not only within the spirit of the invention but also within the scope of the appended claims.

Several definitions must be expressed in order to truly appreciate the capabilities of the presently claimed invention, particularly the “page/find” and “standby” capabilities of WMTS-WLAN-based devices. These capabilities are made possible by and are so intended to take advantage of the “bi-directional (“duplex”) communication capability of WMTS- WLAN DECT-based technology.

“Page/find” is a capability in which a telemetric medical device can be reached (if within range of an AP) in order to cause it to emit audial indications from the device to facilitate determining the device’s location. Alternatively, the page/find capability can be used to prompt a patient to perform a nurse-call function. In either case, the device will respond if its radio module (RM) is in a suitable mode (i.e. in the range of some AP and is not “inactive”). A specialized WMTS-DECT-level function can be used for this function.

“Standby” mode is a capability in which a device can be placed in a sub-operational mode to support “dynamic” care. Stand-by mode occurs only after it has received a confirmation of the request. If the device does not receive the confirmation, then it retries, and if the retries fail, it is assumed that the control failed, and the device should send another “MDS Status ADEdevice” message so as to determine whether the lack of response is because the device is now out-of-range. While in a standby mode, a power-conserving feature of some devices permits a very-low power

25

consumption mode (sleep mode), wherein the device interface's receptivity to messages on the WLAN is effectively limited to being "called" by the AP to wake up. If a device can afford the power, it should try to maintain association even while in Standby mode in order to minimize the time required to "resume latency"; for such purposes only Alert Status updates need to be  
5 maintained.

Some of the uses for Standby mode are:

(1) Patient Monitoring Devices (PMD) are typically placed in a standby mode while awaiting a new patient to be assigned to a given bed. Manual resumption of the operational mode, typically initiated from a central is, is acceptable if not required;

10 (2) Animation Devices are typically placed in standby mode when a patient is ambulating to/from ancillary labs, which may result in Out-of-Range conditions, thus making it more important but complicated to provide automated Page/Find and Resume capabilities, especially when devices are in a power-saving (sleep) mode. In addition, these device are routinely "lost" (i.e. misplaced), sometimes while in standby mode, which further complicates the design.

15 "Auto-resume" describes a feature of a device that resumes an operational mode from a standby mode. This auto resume would occur typically at the device's end, as opposed to a manual resumption of an operational mode, and typically would be initiated from a central station. However, the device may set a count down timer upon being placed in standby mode, so that when the timer expires, the device automatically resumes a normal mode and sends an MDS status to  
20 PIC.

"Auto-reconnect" is a feature that describes a device capability that can respond to a "page/find" message when in-range, and when the device goes out-of-range and has come back in-range, an automatic reconnection takes place because the device periodically seeks connection to the PIC so as to receive a resume control instruction from the PIC when the device is back in-  
25 range. Auto-reconnect does not require manual reconnect triggering when the device comes back into range.

Fig. 1 shows a central-monitoring station 105, which might constitute, for example, a nurse's station in a cardiac-care unit, a central medical unit inside a nursing home or hospice facility, or even an emergency room of a hospital. While an emergency room might not initially seem like the environment for the invention, in fact people are serviced according to priority in an emergency room and Patient Wearable Devices could be assigned upon registration to "keep an electronic eye" on the patient's condition, which could unexpectedly worsen.

Patient Monitoring Devices (PMD #'s 1-4) 110 contain wireless telemetry so that in addition to one or more specific physiological responses being measured, the wireless telemetry allows transmission via a protocol such as DECT, TDMA and/or WMTS back to the central-monitoring station 105.

In addition, Patient Wearable Devices (PWD #1-4) 115 also contain wireless telemetry to report physiological data. However, a PWD is worn by the patient, and may comprise, for example, a wristband and/or armband to monitor blood pressure, portable cardiac monitor, temperature sensor, etc. A PWD contrasts with, for example, a bedside heart monitor that is not worn by the patient, but is connected to the patient; such a device would comprise a PMD.

Alternatively, the central-monitoring station may comprise nothing more than an Access Point in a WLAN that is keeping track of nodes within its broadcasting range, and the AP itself could be hardwired, fiber-optically connected, or wirelessly connected to a proxy server, main server or controller.

It is to be understood that the PMD's 110 are somewhat large devices next to a patient's bed, and generally are portable. Should the doctor decide that the patient needs, for example, an MRI, the orderlies can wheel the patient to that area along with the PMD 110 (the PMD has a battery back-up to keep working while being moved).

The dashed line 120 around a portion of Fig. 1 constitutes the RF range of the central-monitoring site 105. The PWD #2 and PMD #4 are out of range of the central-monitoring station 105. If the central-monitoring station 105 is an AP, it is possible that these devices were "handed off" to another AP in the WLAN.

Each of the PMDs and PWDs each has a radio module (RM) that is adapted to be in one of several meta-states (sub-states), such as standby, active, locked, seeking, or inactive. Similarly, the PWD and/or PMDs themselves have an overall status comprising a plurality of meta-states (shown in Fig. 2B and discussed, *infra*). It is from these different categories of meta-states that the WMTS-  
5 WLAN DECT-based protocol determines the appropriate action.

Fig. 2A shows a list of the major sub-states, and their status alternatives. With regard to standby, the device status can be in an operational mode, or on standby. With regard to (Point of Call) PIC-Association, the device could be pic-associated, pic-disassociated, or in the process of pic-associating. With regard to PIC-Connection, the device could be pic-connected, pic-  
10 disconnected, or pic-connecting. With regard to booting, the devices can be IP-aware (preserving IP allocated addresses), unaware, booting, or rebooting. With regard to range, the devices can be in-range or out-of-range. With regard to Access Points, the devices may be AP associated, or AP-disassociated.

Fig. 2B illustrates some of the various meta-states that can be used by the present  
15 invention. For example box 250 represents an initial state of a PWD device, with the particular state and the status of each state listed. At 255, the standby status is operational, the PIC is associated, the PIC is connected, the boot state is IP Aware, the device is in range of transmission from the PIC. In addition, the Radio Module (RM) state is active, and the timing is inactive.

At box 260 the PWD goes into standby mode, with the RM state locked in the sleep mode.  
20 Note that the timing is active because there can be, for example, a count-down timer so that after a predetermined period the PWD device times out and may connect with the PIC so that a page/find capability would activate the PWD, which a central host might be looking to locate. It should be noted that in box 260 the PWD is PIC-unassociated, the PIC is unconnected, the boot status is IP-Unaware and the RM state is locked. The PWD is still in-range.

25 There are various time-out cases, depending, for example, as to whether or not the PWD is in-range or out-of-range. As the PWD in box 260 is in-range, after timing it may wake up and answer the page/find, thus enabling the device to auto-resume as shown in Box 275. It is noted that

by auto-resuming, the RM status is now active, the PIC is associated and connected, and the AP is associated. The PWD may then go back to the initial state while transmitting requested patient-physiological information back to an AP, PIC and/or central host.

However, a different scenario occurs if the PWD goes out-of-range, as in Box 265. Here, 5 if the device times out, it will not be able to receive/respond to a page/find. In box 265 it is shown that the RM-state is inactive. The out of range case shown would allow a device to go to a locked state when in-range and still timing, then allow the device to auto-resume when timed out.

Box 270 shows what happens when the PWD that was out of range comes back into range. In this case, the PWD had not yet timed out. Upon timeout, an auto-restart occurs. The device 10 particularly needs to manage power in this state. In order to facilitate page/find capability, the PWD device may periodically go to a locked or even an active state; otherwise it would be inactive and unable to respond to page/find requests. Such a device is referred to as an orphan device.

The states described in Fig. 2B require that the PWD contain a timeout mechanism in addition to the DECT-level page/find capability. Moreover, an automatic page/find mechanism 15 may be required if the PIC optimizes latency during the finding of orphan devices or auto-resume from a standby mode.

Fig. 3 provides some detail about how a wireless medical device according to the present invention may be constructed. This drawing is provided only for purposes of illustration and does not limit the invention to the device shown, and there can be many equivalents or different 20 arrangements of the invention.

The Radio module (RM) 116 includes an transmission capability, an antenna (which does not have to be manually extended from the unit), a transmitter, and a receiver. A physical-monitor module 118 can be adapted for the specific physiological response to be measured, for example, pulse. A microprocessor (not shown) may control the RM, the physical-monitor module 118, and 25 other functions of the device. The device can include any or all of a speaker 113, vibrator 119, and light 120, all of which can be used to notify the patient of a nurse call. The nurse-call

acknowledgement 112 can be pressed by the patient to let the central-monitoring station 105 be aware that the patient knows he is to contact them or the nurses as soon as possible.

The DECT-based level page/find method can determine the status of the device either by polling the AP's 104 and 106, or central monitoring station 105. Typically, this method requires multi-AP unicasting or PIC-based broadcasting. It is presumed that if one is looking for a particular device it may be unknown as to which AP is currently associated with, and if the device is non-active, a given AP may be unaware that the device is within its transmission range. The portability of the devices while inactive would account for how a given AP may not be aware that an inactive device has moved to within the AP's transmission field. Network-loading impacts would have to be considered, particularly when a PIC-based periodic polling is used when the device comes back in range.

An example of the way to implement the methodology is to integrate a meta-state model, a specialized AP "proxy" function, and a wireless link "device call" function such that a single device-call control can cause the device to:

- 15 (1) Change to the desired state, i.e., to resume from standby (if the device is in a standby mode); and/or
- (2) Indicate a distinct audial code to the patient to have the patient either press the "nurse call" button or to contact the nursing staff (if the device is not in a standby mode but is associable with the central monitoring system 105); and/or
- 20 (3) Indicate a distinct audial code to facilitate its being locatable by the clinical or bioengineering staff.

For example, in the illustration shown in Fig. 1, patient "Smith" with coronary problems is wearing PWD #1 and resides at a rest home for senior citizens. PWD #1 is fully operational and reporting a variation in heartbeat that is of concern, although not yet a full-fledged emergency. The nursing staff is aware that patient Smith is supposed to take nitroglycerin tablets every 8 hours to stabilize his heartbeat. The central-monitoring station can send out a page/find message to PWD #1. This message activates an audial tone, and during orientation, the patient has been told when

he hears this tone to contact the nurses station immediately. Alternately, or in addition thereto, the terminal audial tone includes a buzzing sound (and sensation). In conjunction with the tone, or instead of the tone, a light may flash.

Alternatively, instead of a tone, the PWD may broadcast a pre-recorded message saying  
5 “call the nurse.” When patient Smith calls the nurse, they can verify with him if he took his medication at its last scheduled time and ask him how he feels. The PWD itself may have a switch that is pressed by the user to acknowledge receipt of the tone/message, which may or may not be transmitted back to the central site. If the patient fails to acknowledge after a certain predetermined time period, or successive tries, the PWD may automatically display an emergency audial tone so  
10 that clinicians can find patient Smith quickly, as he may be unable to communicate with the nurse’s station.

In order to individually communicate with the central monitoring station bi-directionally, the PWD should have a transmission capability so that when the patient presses the acknowledge button, or activates the nurse-call button, communication between the designated AP and the  
15 nurse’s station (e.g central-monitoring station) occurs. Thus, the patient and the doctor or nurse at the central-monitoring station can communicate with each other quickly and easily. Each of the PWDs may use TDMA, CDMA, GSM, FMDA, etc., to differentiate between patients in a WMTS or DECT-frequency spectrum.

In a variation of the above example, the Radio Module of PWD#1 is in a standby mode,  
20 as this PWD only contacts the central monitoring station when the patient’s physiological measurement are out of range and/or a certain period of time has passed. In this case, PWD#1 has not been in communication with the central-monitoring station in three and a half hours. The central-monitoring station is programmed to send out a page to the PWD #1 if four hours have passed without any communication to check the status. As patient Smith may have walked  
25 anywhere along the hospital, all the APs may broadcast a page/find message, which in this case may be a “wake up” signal, followed by a message to the PWD to have the patient call the central-monitoring station.

Of course, if the PWD#1 is out of range of the broadcast message for the patient, there is a possibility that the device remains on the out-of-range/failing lists. In order to reduce the time a device may be unaccounted for, the device may periodically report its status. One way would be according to a timer output. For example, the device could report once for each predetermined  
5 time interval. If there is no return response, the report could be repeated immediately, or at shorter intervals until the device is back within range.

Thus, a series of method steps for the present invention may include:

a) determining the status of a radio module (RM) of one or more wireless-monitoring devices comprising one of a Patient-Wearable device (PWD) and a Patient Monitoring Device  
10 (PMD) that are adapted for dual-communication with one of or more Access Points and a central-monitoring station in a WLAN, wherein the status of the RM comprises one of a plurality of meta-states;

(b) selecting a particular wireless monitoring device for receipt of wireless transmission of a signal that is adapted for changing a meta-state of the device to a desired state if the current state  
15 of the particular wireless monitoring device is not the desired state; and

(c) activating an audial-code function of the particular wireless monitoring device by transmitting an instruction signal to the particular wireless patient-monitoring device to emit a predetermined audial code that can be heard at least by a patient being monitored by the particular  
20 wireless monitoring device, wherein the audial code in step (c) may cause the particular patient-monitoring device to emit a specific tone that indicates to a patient a nurse-call function has been broadcast so that the patient contacts a member of a nursing staff, or to play a prerecorded/preprogrammed message to a patient that requests the patient to contact a member of a nursing staff.

An additional advantage of the present invention is that the audial code comprises a  
25 page/find function so that the audial code played by the particular wireless patient-monitoring device is of a volume sufficient to permit personnel that are unaware of the wireless device's

location to locate the wireless device by listening for the auidial code while walking through the hospital, clinic, nursing home, hospice, medical facility, etc.

Various modifications may be made to the present invention that do not depart from the spirit of the invention or the scope of the appended claims. For example, while one protocol for wireless transmission is WMTS DECT-based protocol, any type of CDMA, TDMA, GSM, FDMA, etc., can be used for transmissions. The medical monitoring device may be worn by a patient, implanted into the patient, or externally arranged on a user's skin. The type of auidial code, volume, and frequency by which it is broadcast can be suited to specific need. Visual aids can be emitted instead of or in conjunction with the auidial code; for example, the device may flash a light when a page/find function is performed. The APs and the devices may communicate under WIFI such as 802.11, and the APs and the central-monitoring station may be linked by wire, fiber, Ethernet, broadband, etc., to name some of the possible connections.

### CLAIMS

1. A method for paging/finding a wireless patient-monitoring device in a WLAN network, comprising the steps of:

(a) determining a status of a radio module (RM) (117) of one or more wireless monitoring devices comprising one of a Patient-Wearable Device (PWD) (115a,115b) and a Patient-Monitoring Device (PMD) (110a,110b) that are adapted for dual-communication with one or more Access Points (104,106) and a central-monitoring station (105) in a WLAN, wherein an overall status of the PWD/PMD comprises one of a plurality of meta-states;

(b) selecting a particular PWD/PMD (115a,115b/110a,110b) for receipt of wireless transmission of a signal that is adapted for changing a meta-state of the device to a desired state if a current state of the particular PWD/PMD (115a,115b/110a,110b) is not in the desired state; and,

(c) activating an audial-code function of the particular PWD/PMD by transmitting an instruction signal to the particular PWD/PMD (115a,115b/110a,110b) to emit a predetermined first audial-code that can be heard at least by a patient being monitored by the particular PWD/PMD (115a,115b/110a,110b).

2. The method according to claim 1, wherein the audial code in step (c) causes the particular PWD/PMD (115a,b/110a,b) to emit a specific tone which provides an instruction for a patient to contact a nurse.

3. The method according to claim 1, wherein the audial code in step (c) causes the particular PWD/PMD (115a,115b/110a,110b) to play a prerecorded/preprogrammed message to a patient that requests the patient to contact a member of a nursing staff.

4. The method according to claim 1, wherein the audial code in step (c) comprises a page/find function comprising a second audial code played by the particular PWD/PMD (115a,115b/110a,110b) wherein said second audial code is of a volume sufficient to permit personnel that are unaware of the wireless device's location to locate the wireless device by listening for the second audial code.

5. The method according to claim 1, wherein determining of the status in step (a) of an RM (117) of one or more wireless devices occurs by polling the one or more Access Points (104,106) via unicasting.

6. The method according to claim 1, wherein determining of the status in step (a) of an RM (117) of one PWD/PMD (115a,115b/110a,110b) occurs by polling the one or more Access Points (104,106) via PIC (Point In Cell) based broadcasting.

7. The method according to claim 1, wherein the RM (117) of one or more PWD/PMDs (115a,115b/110a,110b) uses a Wireless Medical Telemetry System WLAN DECT-based protocol.

8. The method according to claim 7, wherein the overall status of the plurality of meta-states of the PWD/PMD (115a,115b/110a,110b) in step (a) includes operational, standby, sleep, active, locked, seeking, inactive, PIC-associated, PIC-unassociated, PIC-connected, PIC-Unconnected, AP-associated, AP-unassociated, active timing, inactive timing and a designated out-of-range state if the particular PWD/PMD selected in step (a) does not respond.

9. The method according to claim 8, wherein the meta-state in step (b) of the RM (117) of the particular PWD/PMD (115a,115b/110a,110b) is changed to an active state.

10. The method according to claim 8, wherein the meta-states further include: IP-aware, IP-unaware, booting and rebooting.

11. The method according to claim 7, wherein the PWD/PMD 115a,b/110a,b periodically broadcasts the status to the one or more Access Points if the device has not been polled by a predetermined amount of time.

12. A page/find system for wireless medical monitoring devices comprising:  
at least one of a central-monitoring station (105) and a plurality of Access Points (104,106);

a plurality of wireless medical monitoring devices comprising one of a patient wearable device (PWD) (115a, 115b) and a Patient Monitoring Device (PMD) (110a, 110b) that are adapted for dual-communication with the plurality of Access Points (104,106) and the central-monitoring station (105) in a WLAN, wherein the PWD/PMD devices include a plurality of meta-states;

wherein at least said one central monitoring station and plurality of Access Points are adapted for broadcasting a page/find message to a particular PWD/PMD (115a,115b/110a,110b) that signals the particular wireless medical-monitoring device to emit an audial tone at a predetermined volume that can be heard by the patient.

13. The system according to claim 12, wherein the first audial tone emitted by the particular PWD/PMD (115a,115b/110a,110b) comprises a tone that indicates a call nurse function.

14. The system according to claim 12, wherein the predetermined volume is sufficiently loud enough to permit personnel within a facility to locate the particular PWD/PMD (115a,115b/110a,110b).

15. The system according to claim 12, wherein the central station 105 and plurality of AP's (104,106) communicate with the PWD/PMD (115a,115b/110a,110b) by a Wireless Medical Telemetry System using a WLAN DECT-based protocol.

16. The system according to claim 12, wherein the central station 105 and the plurality of AP's (104,106) poll a status of the PWD/PMD (115a,115b/110a,110b) via a PIC (Point In Cell) based broadcast.

17. A patient monitoring device comprising:  
means for monitoring (118) certain physiological responses of a patient;  
a radio module (RM) (117) being adapted for communication with one of a central-monitoring station (105) or a plurality of Access Points (104,106);  
audial-code emission means (113), wherein in response to receipt of a signal, said device emits an audial-code indicating a nurse-call function.

18. A patient monitoring device comprising:  
means for monitoring (118) certain physiological responses of a patient;  
a radio module (RM) (117) adapted for communication (116) with one of a central-monitoring station (105) or a plurality of Access Points (104,106); and

audial-code emission unit (113), wherein in response to receipt of a signal, said device activates a transducer that emits a first audial code at a volume sufficient for a patient to become aware that a nurse-call function has occurred; and,

an acknowledgement button (112) that when activated indicates that a nurse-call function has been acknowledged by the patient.

19. The patient-monitoring device according to claim 18, wherein the audial-emission unit 113 emits a second audial code relatively louder than the first audial code to permit the personnel in a facility to locate the device by listening for the second audial-code.

20. The patient-monitoring device according to claim 18, wherein the audial-emission unit includes a vibrator (119) and a light (120).

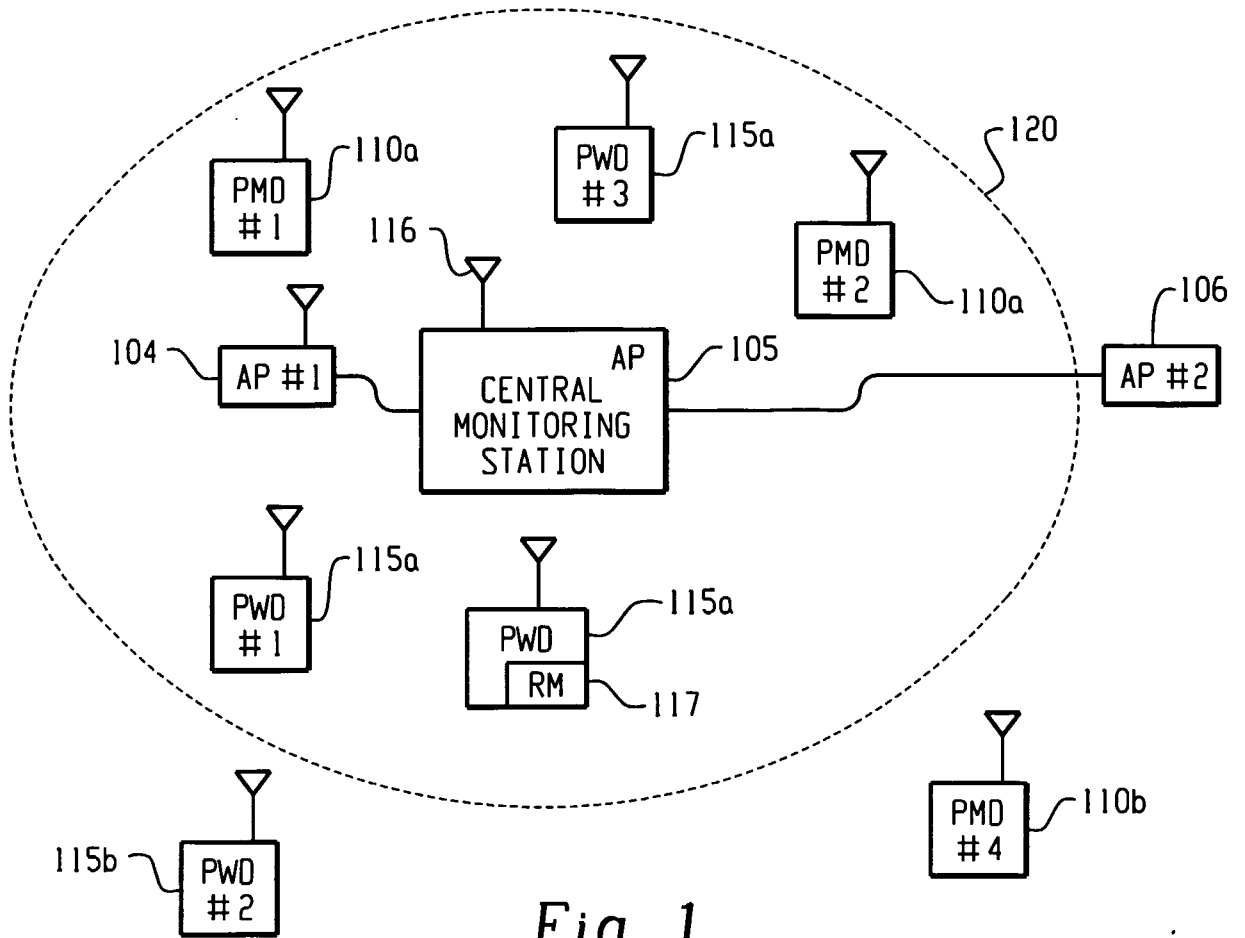

Fig. 1

[Sub-] State	Status alternatives (modeled; related)
Standby	Operational, Standby
PIC-Association	PIC-Associated, PIC-UnAssociated; PIC-Associating
PIC-Connection	PIC-Connected, PIC-UnConnected; PIC-Connecting
Boot	IP-Aware, IP-UnAware; Booting; Rebooting
Range	In-Range, Out-of-Range
AP-Association	AP-Associated, AP-UnAssociated; AP-Associating
RM-State	Active, Locked, Seeking, Inactive
Timeout	--(Not Applicable), Not Timing, Timing, Timed Out

Fig. 2A

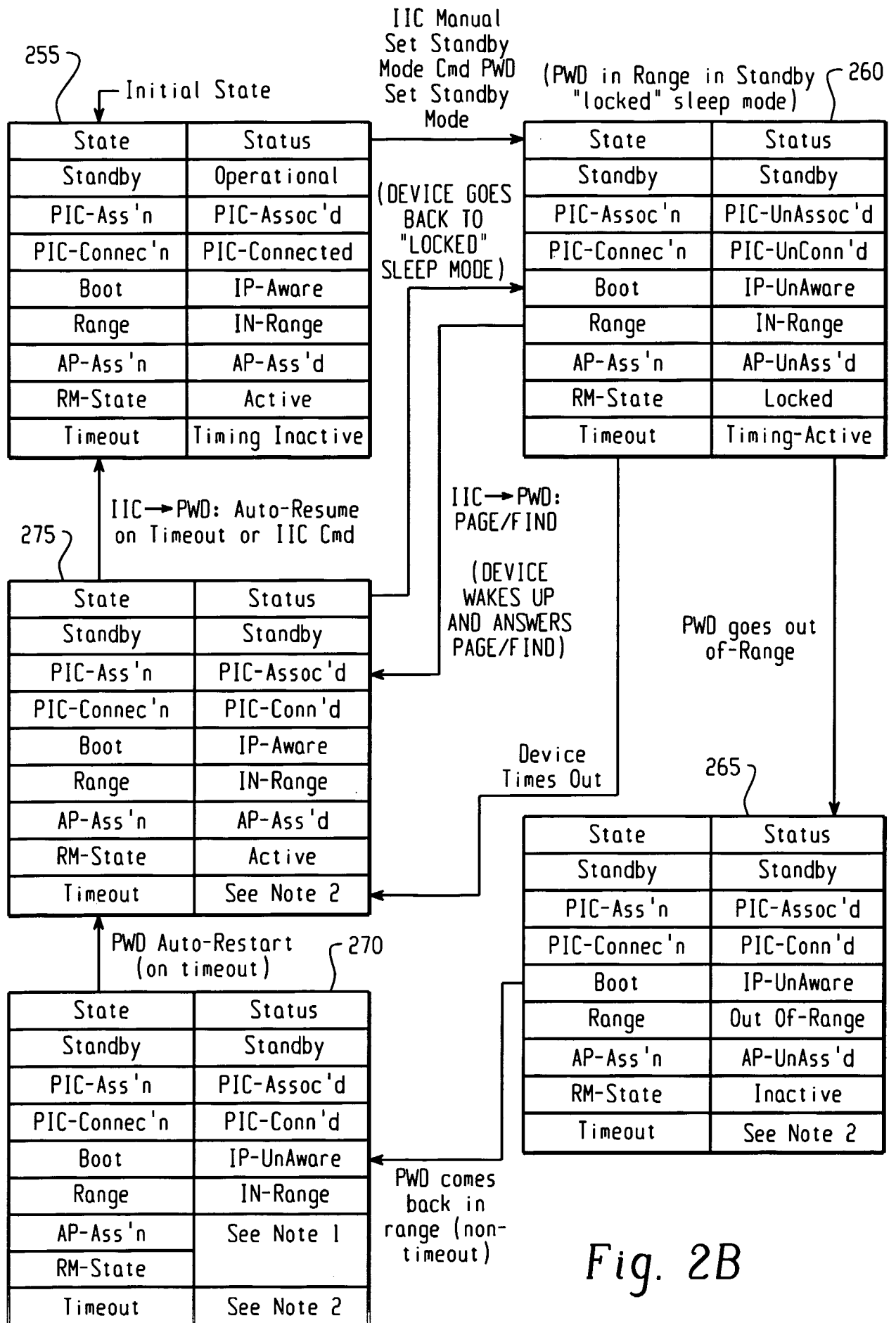

Fig. 2B

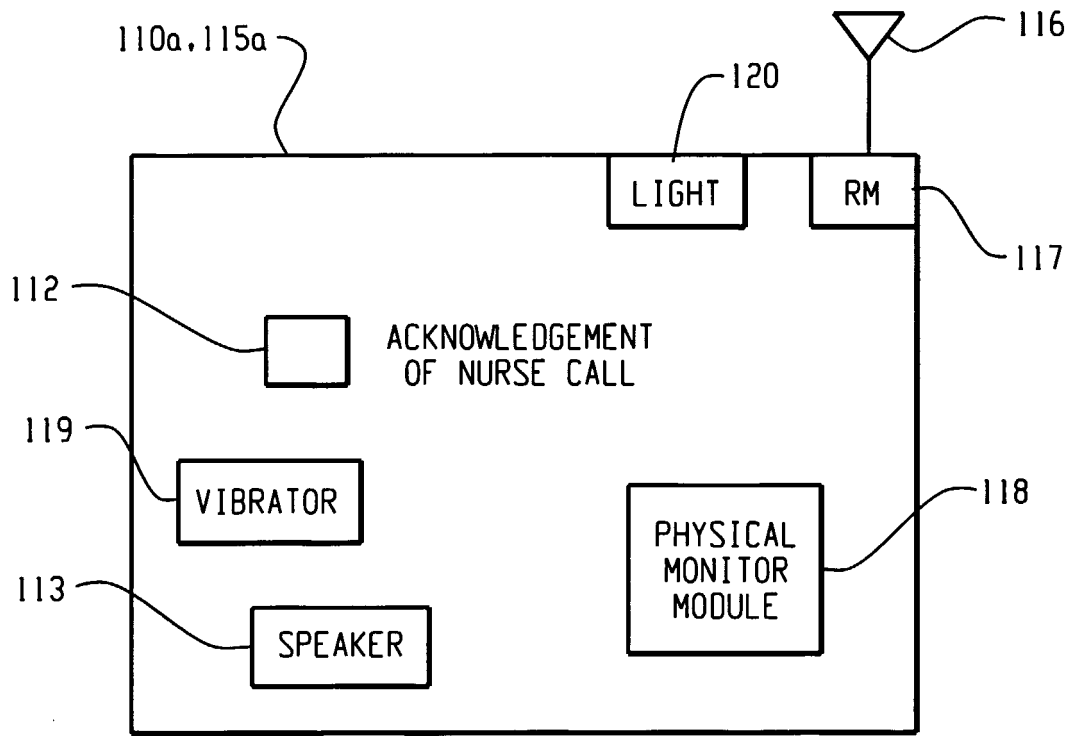

Fig. 3

## INTERNATIONAL SEARCH REPORT

International Application No  
PCT/IB2005/050427

**A. CLASSIFICATION OF SUBJECT MATTER**  
IPC 7 H04L12/28

According to International Patent Classification (IPC) or to both national classification and IPC

**B. FIELDS SEARCHED**

Minimum documentation searched (classification system followed by classification symbols)  
IPC 7 H04L A61B

Documentation searched other than minimum documentation to the extent that such documents are included in the fields searched

Electronic data base consulted during the international search (name of data base and, where practical, search terms used)

EPO-Internal, WPI Data, PAJ

**C. DOCUMENTS CONSIDERED TO BE RELEVANT**

Category °	Citation of document, with indication, where appropriate, of the relevant passages	Relevant to claim No.
X	US 2002/013517 A1 (WEST KENNETH G ET AL) 31 January 2002 (2002-01-31) abstract paragraphs '0002! - '0005!, '0033!, '0036!, '0041! paragraphs '0043!, '0048!, '0052!, '0053!, '0056! paragraphs '0062!, '0063!, '0067!, '0069! - '0075! paragraphs '0081! - '0083!, '0085! - '0087!, '0090! paragraphs '0097! - '0103!, '0115!, '0117!, '0118! paragraphs '0135! - '0147! figures 2,20 ----- -/--	1-20

Further documents are listed in the continuation of box C.

Patent family members are listed in annex.

° Special categories of cited documents:

- \*A\* document defining the general state of the art which is not considered to be of particular relevance
- \*E\* earlier document but published on or after the international filing date
- \*L\* document which may throw doubts on priority claim(s) or which is cited to establish the publication date of another citation or other special reason (as specified)
- \*O\* document referring to an oral disclosure, use, exhibition or other means
- \*P\* document published prior to the international filing date but later than the priority date claimed

- \*T\* later document published after the international filing date or priority date and not in conflict with the application but cited to understand the principle or theory underlying the invention
- \*X\* document of particular relevance; the claimed invention cannot be considered novel or cannot be considered to involve an inventive step when the document is taken alone
- \*Y\* document of particular relevance; the claimed invention cannot be considered to involve an inventive step when the document is combined with one or more other such documents, such combination being obvious to a person skilled in the art.
- \* & \* document member of the same patent family

Date of the actual completion of the international search

24 May 2005

Date of mailing of the international search report

07/06/2005

Name and mailing address of the ISA

European Patent Office, P.B. 5818 Patentlaan 2  
 NL - 2280 HV Rijswijk  
 Tel. (+31-70) 340-2040, Tx. 31 651 epo nl,  
 Fax: (+31-70) 340-3016

Authorized officer

Alonso Maleta, J

C.(Continuation) DOCUMENTS CONSIDERED TO BE RELEVANT		
Category °	Citation of document, with indication, where appropriate, of the relevant passages	Relevant to claim No.
X	<p>WO 02/27640 A (LIFELINK, INC) 4 April 2002 (2002-04-04) abstract page 7, lines 1-28 page 9, lines 4-18 page 12, line 2 - page 13, line 6 page 16, lines 1-14 page 20, lines 5-27 page 24, lines 14-17 figures 3-8</p>	1-20
A	<p>----- IEEE: "Part 11: Wireless LAN Medium Access Control (MAC) and Physical Layer (PHY) Specifications" ANSI/IEEE STD 802.11, 1999 EDITION (R2003), 'Online! 12 June 2003 (2003-06-12), pages 86-137, XP002329193 Retrieved from the Internet: URL:<a href="http://grouper.ieee.org/groups/802/11/">http://grouper.ieee.org/groups/802/11/</a> &gt; 'retrieved on 2005-05-23! page 86, lines 10-27 page 90, lines 1-28 page 92, line 19 - page 93, line 37 page 100, lines 18-30 page 109, line 12 - page 110, line 3 page 111, lines 7,8 page 113, lines 3,4 page 128, line 20 - page 133, line 2 page 135, lines 4-17 page 136, line 15 - page 137, line 16</p>	1-20
A	<p>----- GENERIC: "selection of papers 2002" 'Online! 2002, pages 1-27, XP002329194 Retrieved from the Internet: URL:<a href="http://www.generics.co.uk/uploads%5Cdocs%5Cpublications%5Cpapers202.pdf">http://www.generics.co.uk/uploads%5Cdocs%5Cpublications%5Cpapers202.pdf</a> &gt; 'retrieved on 2005-05-23! abstract page 10, line 9 - page 11, line 13 page 12, lines 16-21 page 15, line 1 - page 17, line 11 table 1 figure 1</p> <p>-----</p>	1-20

## INTERNATIONAL SEARCH REPORT

International Application No  
PCT/IB2005/050427

Patent document cited in search report		Publication date	Patent family member(s)	Publication date
US 2002013517	A1	31-01-2002	AU 6465401 A	03-12-2001
			EP 1404213 A2	07-04-2004
			WO 0189362 A2	29-11-2001
			US 2003206116 A1	06-11-2003
			US 2002013518 A1	31-01-2002
			US 6616606 B1	09-09-2003
<hr/>				
WO 0227640	A	04-04-2002	AU 1182202 A	08-04-2002
			WO 0227640 A2	04-04-2002
<hr/>				

专利名称(译)	用于无线医疗监测和患者监测设备的方法和相关系统		
公开(公告)号	<a href="#">EP1719293A1</a>	公开(公告)日	2006-11-08
申请号	EP2005702865	申请日	2005-02-01
[标]申请(专利权)人(译)	皇家飞利浦电子股份有限公司		
申请(专利权)人(译)	皇家飞利浦电子N.V.		
当前申请(专利权)人(译)	皇家飞利浦N.V.		
[标]发明人	WITTENBER JAN BARGA JOHN ROSNOV BRIAN S KOSCHEK ANDREW G		
发明人	WITTENBER, JAN BARGA, JOHN ROSNOV, BRIAN, S. KOSCHEK, ANDREW, G.		
IPC分类号	H04L12/28 A61B5/00 A61B5/0205		
CPC分类号	A61B5/02055 A61B5/002 A61B2560/0209		
优先权	60/545819 2004-02-19 US		
外部链接	<a href="#">Espacenet</a>		

#### 摘要(译)

用于在WLAN网络中寻呼/寻找无线患者监测设备的方法包括确定包括患者可穿戴设备(PWD)之一的一个或多个无线监测设备的无线电模块(RM)(117)的状态的步骤。(115a, 115b)和患者监测设备(PMD)(110a, 110b),其适于与WLAN中的一个或多个接入点(104,106)和中央监测站进行双重通信。PWD/PMD的总体状态可以是多个元状态,包括待机,不活动,活动,睡眠。在确定状态之后,存在用于接收信号的无线传输的特定PWD/PMD的选择,该信号适于在特定无线监测设备的当前状态下将设备的元状态改变为期望状态。不是理想的状态。通过将指令信号发送到特定无线患者监测设备以发出预定的第一听力代码来激活特定无线监测设备的听力代码功能,该预定的第一听力代码至少可由特定PWD监测的患者听到/PMD,以便指示患者联系护士站。作为另外一种选择或除此之外,可广播第二音频音调,其以足够大的音量发射以允许诊所或设施人员四处走动并通过声音定位该设备。