

(19) World Intellectual Property Organization
International Bureau



(43) International Publication Date
27 December 2001 (27.12.2001)

PCT

(10) International Publication Number
WO 01/98935 A2

(51) International Patent Classification⁷: G06F 17/00

10021 (US). RICE, John, Jeremy; 1534 Kimble Avenue, Mohegan Lake, NY 10547 (US).

(21) International Application Number: PCT/US01/19918

(74) Agent: RESTAINO, Leslie, Gladstone; Brown Raysman Millstein Felder & Steiner LLP, 55 Madison Avenue, Morristown, NJ 07960 (US).

(22) International Filing Date: 22 June 2001 (22.06.2001)

(25) Filing Language: English

(81) Designated States (national): AE, AG, AL, AM, AT, AU, AZ, BA, BB, BG, BR, BY, BZ, CA, CH, CN, CO, CR, CU, CZ, DE, DK, DM, DZ, EE, ES, FI, GB, GD, GE, GH, GM, HR, HU, ID, IL, IN, IS, JP, KE, KG, KP, KR, KZ, LC, LK, LR, LS, LT, LU, LV, MA, MD, MG, MK, MN, MW, MX, MZ, NO, NZ, PL, PT, RO, RU, SD, SE, SG, SI, SK, SL, TJ, TM, TR, TT, TZ, UA, UG, UZ, VN, YU, ZA, ZW.

(26) Publication Language: English

(30) Priority Data:
09/599,128 22 June 2000 (22.06.2000) US

(71) Applicant: PHYSIOME SCIENCES, INC. [US/US];
150 College Road West, Princeton, NJ 08540-6604 (US).

(84) Designated States (regional): ARIPO patent (GH, GM, KE, LS, MW, MZ, SD, SL, SZ, TZ, UG, ZW), Eurasian patent (AM, AZ, BY, KG, KZ, MD, RU, TJ, TM), European patent (AT, BE, CH, CY, DE, DK, ES, FI, FR, GB, GR, IE, IT, LU, MC, NL, PT, SE, TR), OAPI patent (BF, BJ, CF, CG, CI, CM, GA, GN, GW, ML, MR, NE, SN, TD, TG).

(72) Inventors: COLATSKY, Thomas, J.; 825 Springbank Lane, Wayne, PA 19087 (US). MUZIKANT, Adam, L.; 211 North Harrison, Princeton, NJ 08540 (US). ROUNDS, Donna; Apt. No. 11M, 201 East 69th Street, New York, NY

[Continued on next page]

(54) Title: COMPUTATIONAL SYSTEM FOR MODELLING PROTEIN EXPRESSION IN AN ORGAN

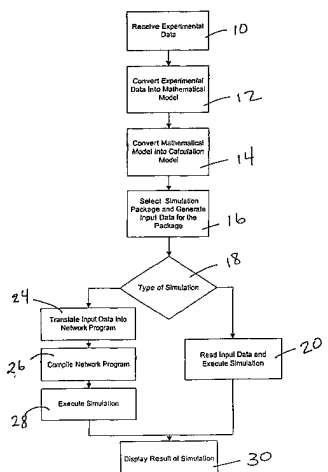

(57) Abstract: A computational model of an organ is disclosed along with a process for assessing the microscopic and whole organ impact of genetic differences that occur in single cells comprising the organ. The genetic differences in the model are based on changes on protein function or distribution associated with genetic mutations, gender, disease or allele based variations in the pattern of gene expression.

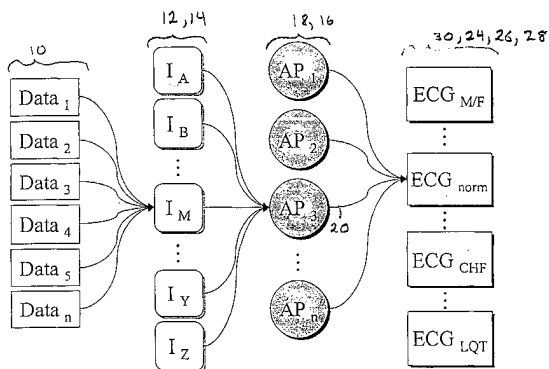

WO 01/98935 A2





Published:

— *without international search report and to be republished upon receipt of that report*

For two-letter codes and other abbreviations, refer to the "Guidance Notes on Codes and Abbreviations" appearing at the beginning of each regular issue of the PCT Gazette.

**COMPUTATIONAL SYSTEM FOR MODELING
PROTEIN EXPRESSION IN AN ORGAN**

CROSS REFERENCE TO RELATED APPLICATIONS

5 The present invention claims the benefit of provisional application 60/140416, filed 6/22/1999 with the same title. The application incorporates by reference the disclosure of co pending U.S. Patent Application Serial No. 09/305,188 filed May 04, 1999 in its entirety.

FIELD OF THE INVENTION

10

The present invention relates to computer models of organs implemented in software and more particularly to an organ model that enables one to study the effects of protein expression on organ performance and biofunctionality.

BACKGROUND OF THE INVENTION

15

U.S Patent 5,947,899 shows how to create a computational model of a complete organ. That disclosure is set forth in the context of a whole heart model where the anatomic relationships between cardiac cells are modeled by a set of coupling relationships between nodes of a network. Each node represents a physical subunit of tissue. A separate set of equations define the electrophysiology of the individual cardiac cells and these equations are used to compute an action potential (AP) at each node. The time course of the action potential may be represented graphically and compared with physical measurements made experimentally.

20

In this architecture, each node of the model has two computationally separate types of information associated with it. A distinct advantage of the model is the ability to compute the local and global portions of the model simultaneously and independently while allowing the local and global processes to interact.

25

Since the network itself reflects the global anatomic relationships between cells or groups of cells and the nodes represent the metabolic actions at the local level the model paradigm allows for the integration of interaction between the local physiological data and the global coupling relationships. As a consequence the cellular activity is propagated in a realistic way over the whole organ and whole organ behavior flow directly from the model.

30

This methodology allows one to compute the gross macroscopic biofunctionality at the organ level arising out of discrete populations of single cell models. The gross behavior of the model can be compared with physical experiments for verification and the detailed cellular modeling can be compared with
5 electrophysiologic experiments as well.

However, in spite of these advances, there is a continuing need to expand the generality of the model to other organs and systems, and to extend the model to simulate the impact of other cellular, subcellular, genetic and molecular processes.

SUMMARY OF THE INVENTION

10

In the present invention, a partial organ model is described which can be used to explore and model the impact of genetic and sex linked cellular changes on the organ. Genetic differences in the model are modeled by noting and modeling the changes in protein function or distribution or transportation associated with genetic
15 mutations, sex differences, disease or allele based variations in the pattern of gene expression.

In general, experimental measurements of molecular properties, single cell activity or protein function in normal or genetically altered cellular systems are gathered and expressed as equations which describe the observed action potential of
20 isolated cells or tissues.

This information is combined with anatomic data in the model. In general, virtual "cells" are constructed and then assembled together into the network. Each node location in the network reflects a different physical location. The virtual cells that occupy various sections of the model network will typically differ in the node
25 equations that describe the action potential. It is also common that the coupling relationships differ between regions of the network.

The protein computations impact the action potential of all cells but depending on the actual location in the network the actual time course of an individual's cells action potential may vary dramatically from its neighbors.

30

This technique is useful for determining the impact of a mutation or sex on the performance of an otherwise equivalent organ. The ability to model some sex based changes and to ignore others within the model domain is a very useful and a feature not easily available in physical models.

The utility of this modeling process is the ability to determine mutation induced changes in response to disease, drugs, or other perturbations in transmembrane potential. The organ model is also useful for determining differences in the response to drugs, genetic mutations, or disease expression related to sex and allelic variations in cellular background.

The invention is illustrated in the context of a heart wedge model and the node computations take into account sex based differences in protein expression as well as variations in cell type. At the organ level the model simulates sex based reactions to drugs. In this model the initial conditions are perturbed by a simulated stimulus which is propagated at the network level and which influences the time course of the action potentials computed at each node.

The cells types illustrated are excitable cells which signal by changing their transmembrane potentials. The invention may be utilized to model other system with excitable cells and the heart wedge illustration is exemplary and not intended to be limiting.

BRIEF DESCRIPTION OF THE DRAWINGS

Throughout the various figures of the drawing identical reference numerals indicate identical structures or processes. The embodiments of the invention shown are illustrative and should not be taken as limiting the scope of the invention, wherein:

FIG. 1 has a panel 1A that is a simplified flow chart describing the creation and computation of the model, panel 1B is an alternate schematic representation of the model and the model building process;

FIG. 2 includes panel 2A which is a schematic representation of an organ, and panel 2B which is a schematic representation of a network model showing a lattice of nodes and relationships between nodes;

FIG. 3 is graphic representation of action potentials presented as panel 3A and panel 3B;

FIG. 4 includes panels 4A, panel 4B, and panel 4C, which are computed action potentials related to sex;

FIG. 5 is a computed action potential related to sex based differences in the effect of a drug;

FIG. 6 is presented as panel 6A that shows experimental data and panel 6B that represents simulation; and

FIG. 7 is a series of panels that represent in panel 7A and panel 7B action potentials of mutation based variations in protein expression, panels 7C and 7D show the variation of action potential as a function of cell type.

5

DETAILED DESCRIPTION

Overview

The invention is both a computation model and related methods for modeling a biologic organ, the steps of the process are carried out on a general purpose computer. The computer is not shown in the figures explicitly. However the figures are the result of the computations carried out according to the software processes described.

The method of the invention begins with the collection of experimental data related to the molecular properties and physiology of cells with normal and mutant gene expression. The most interesting interactions are the protein interactions that involve the transmembrane ionic currents. In the case of gene mutations specifically, the impact of mutation on protein function, and secondarily, the impact on the transmembrane potentials and other features of cell activity are explored in detail, including biophysical changes in the ion pumps, transmembrane channels, receptors and signaling pathways. Experimental data provide the parameters needed to model a single cell containing proteins having both "normal" and "aberrant" functionality. The profile of cellular functionality is thus developed and the general set of equations is extended to model complex behaviors of the cell.

In this step of the process, molecular properties of the gene or protein are measured and alterations in expression levels or patterns of expression for a particular gene or protein are noted. For example certain proteins appear to increase the number of channels that are open. Other proteins are responsible for the magnitude of the current across the membrane.

The resulting physiological properties of the mutation are characterized by alterations in the time course of the membrane current, transmembrane potential, ion flux, or biochemical reaction rate. At the conclusion of this data collection and representation step the impact of protein function on the action potential can be shown graphically and used computationally.

These data and information are used to create or modify single cell models. The network model is an ensemble of the single cell models that integrates these changes in the biofunctionality of the cells into a whole organ or portion of an organ. Gender may be modeled in a similar fashion in that sex-specific differences associated with protein type, location, and other molecular and physiological properties are used to modify the cellular models.

The anatomic detail is required to model disease accurately and the incorporated organ model is required to allow this spatial distribution of cells into nodes and subsequently intact tissue. With the node locations and local equations defined, the model is solved and results displayed. It is a convenient property of the model methodology that the node computations can be performed simultaneously and independently of each other, thus allowing the model to be implemented effectively on parallel computers. Heterogeneity in the spatial distribution of the mutation or mutations can also be modeled, as well as altered gene or protein expression patterns in the organ, by specifying different cellular, subcellular, and molecular properties at individual nodes within the complex model. Various aspects of the modeling process are also presented in U.S. Patent 5,947,899.

Data Collection

FIG. 1 is a flowchart that shows a stepwise sequence for both a single cell model and an organ level model. In general, processes 10 through 16 represent the data collection and construction of a single cell model. Processes 24 through 28 involve the creation of the network model of the organ or a part of the organ, while process 20 reflects the computation of a single cell model. Process 30 reflects the output of either simulation and typically both graphic data and data in tabular form are created. Although process 18 represents a choice between single cell and multi cell models it should be understood that simulations at the cellular level may be used to validate the single cell model against experimental data while network level organ simulations can be used to validate the organ level description against experimental tissue experiments.

In process 10 experimental data concerning the behavior of the altered cell type, and the specific functional properties of the target protein are collected. This is a very labor intensive step because the data are presented in various formats and may require substantial searching to uncover the appropriate literature or source for the

experimental data. It is common for wet lab experiments to be reported both on line and in paper journals. In any given instance the investigator or author may show a measured action potential from an isolated cell or group of cells. Gene sequencing may show which proteins are active at the time of the electrophysiologic measurement.

5 The data may be available to other investigators in the form of computer files representing raw measurements and the protein expression data may be accompanied with a wealth of ancillary data. However, the quality of the data is always problematic. A generalized set of acceptance criteria may be developed. At present “in specie” as opposed to “outside specie” work is preferred. Although many protein

10 interactions are similar across cell lines there is no way to determine a priori whether this is true for a particular study. Nominal data taken in “usual” circumstances is preferred to data taken during “unusual” metabolic conditions. It is likely that “trusted” sources of data taken in accord with a defined protocol will be preferred.

15 Model Building

In process 12 those data collected in step 10 are used to modify the system of nonlinear ordinary differential equations (ODEs) defined at each node of the lattice, and to modify the ionic currents of the cellular model. These equations define the biophysical processes giving rise to the unique properties of cardiac tissue and the various cardiac cells. In general, this system includes: a) equations defining properties

20 of nonlinear, voltage-gated transmembrane currents; b) equations describing properties of ion pumps, exchangers and other features in the cell; c) equations describing the buffering, uptake, storage, transfer, and release of calcium ions by intracellular organelles; d) equations describing time-varying changes of intracellular ion

25 concentration, and e) equations describing the effects of neurotransmitters, hormones and second messengers on these components.

A useful paradigm for modeling cellular dynamics is a battery/resistor/capacitor model where the membrane currents are the sum of a set of voltage sources in parallel with a capacitance. The voltage sources are modeled as

30 a battery in series with a resistor. The battery represents the driving force for ionic flux through the channel provided by the ionic gradient across the membrane. The resistor represents the resistance to ionic flow through the pore of the channel. Mathematical models for most ionic currents can be taken directly from data collected in step 10. The general form of the equation is $I_{\text{channel}} = I_{\text{openchannel}}(V) * P_{\text{open}}$ where the

desired channel current is a function of a voltage dependant open channel current and the state of the pore as opened or closed. Various methodologies known in the literature including Hodgkin-Huxley and Markov state modeling can be used to estimate the open channel and closed channel currents. The simple electrical model
5 allows easy accommodation of additional current values and estimates. This electrical circuit analogy mates easily with the network node portion of the model used to represent anatomy. It is important to note that this methodology models each ionic current separately and independently. This means that the ionic currents may be added to the model without revising other portions of the model. This independence allows
10 modularity in construction and facilitates model refinement. In general mutation or sex based expression will result in differing amounts of protein available for modulation of transmembrane currents. The cell level model computes action potentials based on the availability of the requisite proteins.

Another significant value of this methodology is the ability to validate the
15 cellular model alone. In essence, predictions based upon data and modeled currents can be compared to experimental data to verify the predictive value of the cell model before inclusion into the organ and system model. Fine tuning of the model can be accomplished more easily because of this partitioning and architecture.

Process step 14 relates to making the ionic current calculations
20 computationally efficient. Many techniques are available to compute sets of ordinary differential equations. Process 16 relates to the selection of the particular simulation methodology used to analyze the data. For example, some a priori knowledge may allow the user to ignore some variable or make other simplifying assumptions for a particular simulation. In a typical setting a user may have several "single cell" model
25 available and each will "work". The specific choice for a particular study may be simply a user preference.

In process 18 a single cell or network model is selected. Users may begin with a series of single cell simulations and then select a network model without redesigning the single cell model.

30 Processes 24 through 28 relate directly to structuring the network model by defining the location of altered cells in the physical representation of the organ. Typically a finite difference lattice work of nodes are preferred to represent physical structure of the heart and the physical locations for mutated cells. This spatial placement is based upon anatomic knowledge. It is important to note that all or just

some cells may have the altered properties. FIG. 2 address this aspect of the model in more detail.

The output data from the simulation are available in process 30. Various figures such as FIG. 2A, FIG. 3, FIG. 4, FIG. 5, and FIG. 7 represent examples of the
5 output from process 30. Both graphic and tabular data is available.

The extension of the model to a specialized tissue preparation and the operation of the model are facilitated by a brief discussion of FIG. 2. FIG. 2A is schematic representation of three groups of cells or tissues in a portion of a "wedge"
10 of cardiac tissues. The tissue group typified by cell 42 (A) is on the interior of the "wedge" and represents an endocardial surface. Cells typified by cell 44 (B) occupy the interior of the wedge while cells typified by cell 46 (C) lie on the outer surface of the wedge and are representations of the epicardial surface. In general these autonomous cell layers will have characteristics action potentials depicted in panel
15 for the corresponding tissue type. The wide variation in the duration of the action potentials is demonstrating the dynamic behavior of the organ model when paced at various rates. The dispersion in duration of action potentials mimics or models a similar behavior seen in physical wedge preparations. The longest duration corresponding to trace 43 are the result of pacing at about 5s intervals and the shorter duration typified by trace 41 represents "fatigue" and non linear behaviors at faster
20 pacing rates corresponding to about 500ms intervals.

The A, B and C types of tissue can depolarize giving rise to a voltage. Currents associated with this voltage can be communicated to the companion tissue groups. This coupling relationship is the fundamental requirement of the organ model. The relationship between the tissues is represented in the Figure can give rise to
25 superficial or surface waveforms that follow the surface of the tissue wedge. In this fashion local events in tissue groups are communicated to neighboring tissues. It is common to begin the model at time $T=0$ with a current stimulus to initiate depolarization of one or more cells. This initial perturbation causes the dynamic features of the model presentation seen as the depolarization waveform 47 in FIG. 2A.
30 The duration of the response is extremely sensitive to the time between stimuli. Once the model is running the states of the various virtual cells diverge in a manner that may be difficult to predict under some circumstances. The various displayed durations for the activation potentials seen in panel 2A "B" for example reflect cycle to cycle variations. Each of the different traces of action potential seen in the figure arises at a

different cycle length. This figure shows how a simple single cell model buried in a dynamic organ model can exhibit realistic cycle to cycle variation in action potential.

FIG. 2b shows the network model used to model the physical specimen of FIG. 2a. In FIG. 2b the node 54 is receiving activation from the neighbor node 52. However the communication is not symmetrical and the coupling relationship is diode-like. Symmetrical communication is allowed between node 54 and node 56 as indicated by the double arrow head configuration of coupling relationship 58. The loop 55 represents the iterative calculation of the local biophysical equations used to model the action potential of the tissues represented by the node 54. It is the value of the model that it can solve local equations and compute the interaction of the local data to give rise to overall activity of the organ. The family of coupling relationships shown in FIG. 2b allow the construction of heterogeneous tissue structures using identical cell types. Heterogeneity can also be achieved by varying the cell type in various locations in the model. Anatomic linkages and pathways can be accurately reproduced by selecting the correct coupling relationship.

FIG. 3 shows a first panel 3A that represents the action potential 60 of a male cell and an action potential 62 of a female cell. In this modeling experiment the sex based differences in protein expression, uptake and transport has related in a substantially different action potentials waveforms. The female trace 62 shows an extended repolarization time. Panel 3B is labeled with the name of the current tracked for sex based differences in protein expression. There are no uniformly followed naming conventions for proteins although the labels in the figure are in common usage. The B.Ito current is the transient outward current. The C.IKr current is the delayed rectifier current. The D.IK1 current is the inward rectifier current. E.IKs current is the slow delayed rectifier current. The disparity between male 66 and female 68 in the IKr channel provides an insight into the morphology of the tissue electrophysiology seen in panel 3A. This output represents the ability of the model to display important electrophysiologic consequences of modest allele or sex based variations in protein expression.

FIG. 4 illustrates the impact of cell type on the cardiac action potential for "male" 71 and "female" 69 cells of various cells within the wedge model. The wedge model accurately displays significant variations in action potential duration and morphology based on differences in protein to expression in cells which differ solely by "sex". This illustration points out that the simulation allows the user to "fix" a set

variables and allow only specific sex linked or allele based variation to drive the model. In this fashion subtle variations in protein expression can be revealed.

Figure 5 shows the effects of sex-based differences in the expression of specific ion channels on the computed action potential for "male" and "female" cardiac ventricular cells. In each complex in the figure typified by complex 77 the "male" duration is the shorter of the two durations as typified by trace 75. In this complex 77 the longer trace 73 is "female". The figure shows the differential impact of a drug acting on these cells. As the drug dose increases, the percent of channel blockage increases, resulting in a proarrhythmic response as indicated by the appearance of early depolarizations especially in females. The alternans exhibited in the 60% blocked channel shows up in the female model but not the male model. The alternans is noted by comparing the sequence of complexes 79, 81, 83, 85 and 77. The long potentials followed by short potentials is the hallmark of the arrhythmia. Although this illustration is modeled with d-sotalol it is likely valid for all potassium blocking drugs. The figure shows multiple events paced at an interval of approximately 2.5 seconds. The multi-dimensional impact of these gender-based differences, alone and in combination with drug, can be illustrate using a simulated electrocardiogram as the read-out. This illustration shows channel blockages corresponding to an "overdose" of drug. The computer model is substantially more tolerant of overdose than an experimental preparation. The results provide a mechanistic explanation for the prolonged electrocardiographic QT, and for the increased incidence of drug-induced proarrhythmia interval typically observed in females vs. males.

Figure 6 shows in panel 6A classic data of the type collected in process step 10. The data show variations in myocytes based on location and based on pacing rate. The simulations of panel 6B are taken under the same conditions and they show good agreement with the experimental data thus validating the model. The ability to test the model and various scales in time and space is an important attribute of the architecture of the model.

Figure 7 has a panel 7A which represents a normal (wild) genotype ECG 96 taken from a network model. Corresponding panel 7C shows the action potentials of myocyte at various levels in the simulated wedge epicardial cells are shown by trace 90, midmyocardial cells are shown by trace 91 and endocardial cells are shown at 92. Panel 7B shows a mutation that impacts the surface ECG 97. The individual behavior

of the corresponding myocytes seen in trace 93, 94, and 95 in panel 7D shows the corresponding action potentials for the myocyte locations.

CLAIMS

1. A method of computer modeling a portion of an organ comprising:
defining a first set of nodes and a second set of nodes;
5 said first set of nodes representing a first physical subunit of the organ;
said second set of nodes representing a second physical subunit of the
organ different from said first physical subunit;
said first set of nodes having a first set of biophysical equations expressing
the transmembrane currents associated with action potentials related directly to the
10 expression of protein modeled at the node;
each node having a set of coupling current equations representing the
anatomy of the organ at the location of the node;
defining a network having a node at each vertex of the network lattice
whereby the node location and coupling current equations represent the location of the
15 node in the organ;
activating the model by simulating a stimulation current activation event at
a set of nodes, said set of nodes being a subset of all nodes in the network;
solving said sets of biophysical equations to determine node currents for
each node;
20 summing said node currents to determine the voltage present at each node;
and
displaying a representation of said computed voltage.
2. The method of claim 1 wherein the solving step iterates the model
25 over computation cycles that model the time course of the action potential including
depolarization events and repolarization events extending from the initial activation
event.
3. The method of claim 2 wherein each action potential is used to define
30 a single computation cycle.
4. The method of claim 1 wherein said activation event is applied at a
single node.

5. The method of claim 1 wherein said activation event is applied to a set of nodes at the exteriors of said network lattice.

6. The method of claim 1 wherein said first set of nodes represents
5 epicardial cardiac cells and said second set of nodes represents midmyocardial cells.

7. The method of claim 1 wherein said first set of nodes represents endocardial cardiac cells and said second set of nodes represents midmyocardial cells.

10 8. The method of claim 6 wherein said first set of nodes represents epicardial cardiac cells and said second set of nodes represents midmyocardial cells.

9. A computational model of a portion of the heart comprising:
a three dimensional network representing a cross section tissue wedge of a
15 ventricle of a heart;

said network having a set of nodes, each node forming the vertex of the network;

a first set of nodes representing epicardial cells located in a first portion of the network;

20 a second set of nodes representing midmyocardial cells located in a second portion of the network contiguous with said first portion of the network;

a third set of nodes representing endocardial cells located in a third portion of the network contiguous with said second set of nodes of the network;

25 a set of node coupling relationships that share current and voltage variations between adjacent nodes;

a set of node transmembrane current equations that represent the role of allele based variations in protein expression on transmembrane current computed for each node;

30 a computer process for calculating the node current equations and for computing the node coupling relationships and for summing the resultant currents and voltages over all the nodes; and

a computer process for displaying the results of the summing calculation.

10. A method of computer modeling a portion of an organ comprising:
35 defining a first set of nodes;

said first set of nodes representing a first physical subunit of the organ;
defining a first set of biophysical equations for said first set of nodes
expressing the transmembrane currents associated with action potentials related
directly to the expression of protein modeled at the node;

5 collecting said first set of nodes into a lattice like network, said network
having a node at each vertex of the network lattice whereby the node location and
coupling current equations represent the location of the node in the organ;

 activating the model by simulating a stimulation current activation event at
one of said nodes, said activation event defining the start of a computation interval of a
10 selected duration;

 solving said sets of biophysical equations to determine node currents for
each node;

 summing said node currents to determine the voltage present at each node;
and

15 displaying a representation of said computed voltage at said nodes
evolving as a time course over said computation interval.

11. The method of claim 10 wherein said activation step is repeated at the
conclusion of said computation interval.

20 12. A computational model of a portion of the heart comprising:

 a three dimensional network representing a cross section tissue wedge of a
ventricle of a heart;

25 said network having a set of nodes, each node forming the vertex of the
network;

 a first set of nodes representing epicardial cells located in a first portion of
the network;

 a second set of nodes representing midmyocardial cells located in a second
portion of the network contiguous with said first portion of the network;

30 a third set of nodes representing endocardial cells located in a third portion
of the network contiguous with said second set of nodes of the network;

 a set of node coupling relationships that share current and voltage
variations between adjacent nodes;

a set of node transmembrane current equations that represent the role of sex based variations in protein expression on transmembrane current computed for each node;

5 a computer process for calculating the node current equations and for computing the node coupling relationships and for summing the resultant currents and voltages over all the nodes; and

a computer process for displaying the results of the summing calculation.

13. A computational model of a portion of the heart comprising:

10 a three dimensional network representing a cross section tissue wedge of a ventricle of a heart;

said network having a set of nodes, each node forming the vertex of the network;

15 a first set of nodes representing epicardial cells located in a first portion of the network;

a second set of nodes representing midmyocardial cells located in a second portion of the network contiguous with said first portion of the network;

a third set of nodes representing endocardial cells located in a third portion of the network contiguous with said second set of nodes of the network;

20 a set of node coupling relationships that share current and voltage variations between adjacent nodes;

a set of node transmembrane current equations that represent the role of sex based variations in protein expression and drug based variations on transmembrane current computed for each node;

25 a computer process for calculating the node current equations and for computing the node coupling relationships and for summing the resultant currents and voltages over all the nodes; and

a computer process for displaying the results of the summing calculation.

30 14. A computational model of a portion of the heart comprising:

a three dimensional network representing a cross section tissue wedge of a ventricle of a heart;

said network having a set of nodes, each node forming the vertex of the network;

a first set of nodes representing epicardial cells located in a first portion of the network;

a second set of nodes representing midmyocardial cells located in a second portion of the network contiguous with said first portion of the network;

5 a third set of nodes representing endocardial cells located in a third portion of the network contiguous with said second set of nodes of the network;

a set of node coupling relationships that share current and voltage variations between adjacent nodes;

10 a set of node transmembrane current equations that represent the role of drug dose variations in protein expression on transmembrane current computed for each node;

a computer process for calculating the node current equations and for computing the node coupling relationships and for summing the resultant currents and voltages over all the nodes; and

15 a computer process for displaying the results of the summing calculation.

FIG. 1A

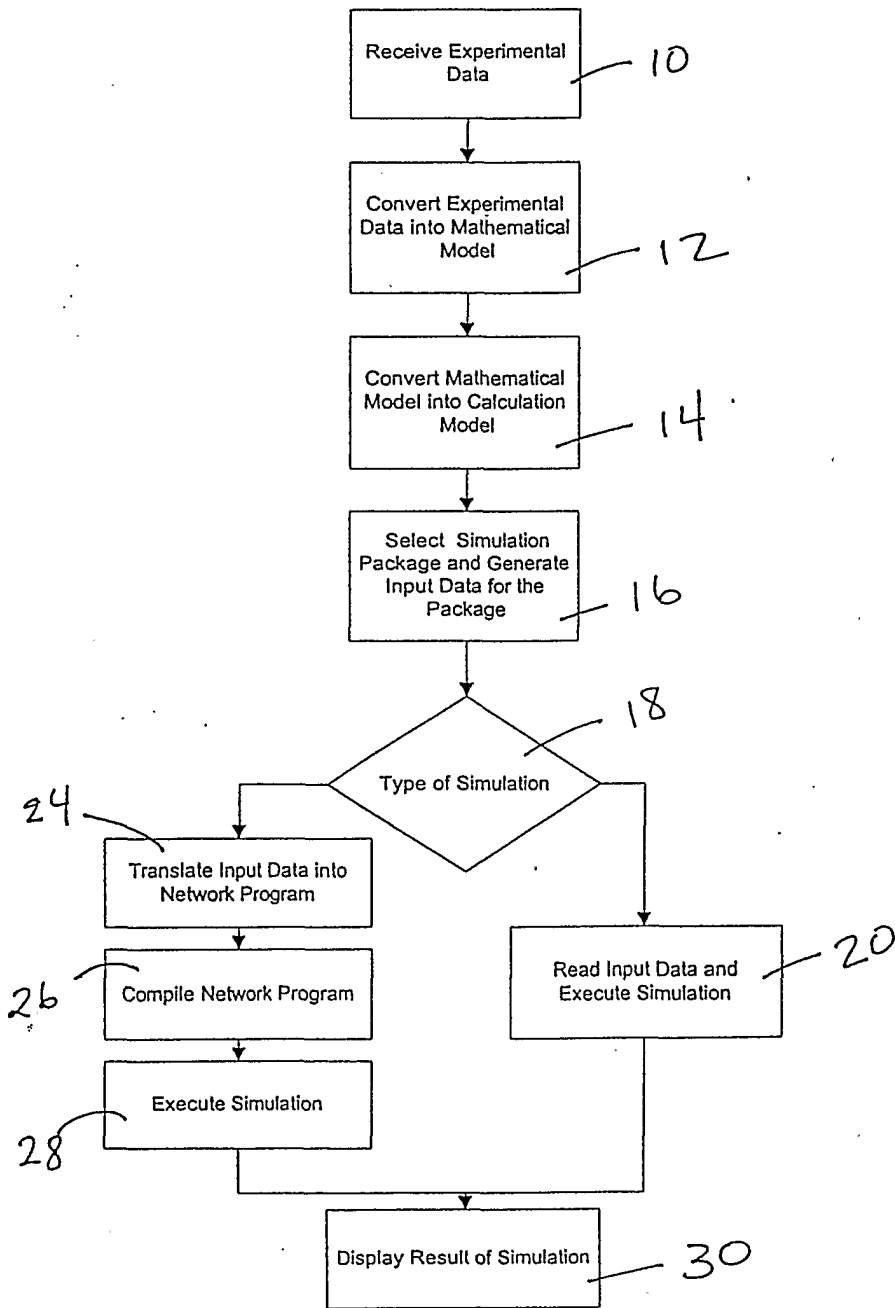
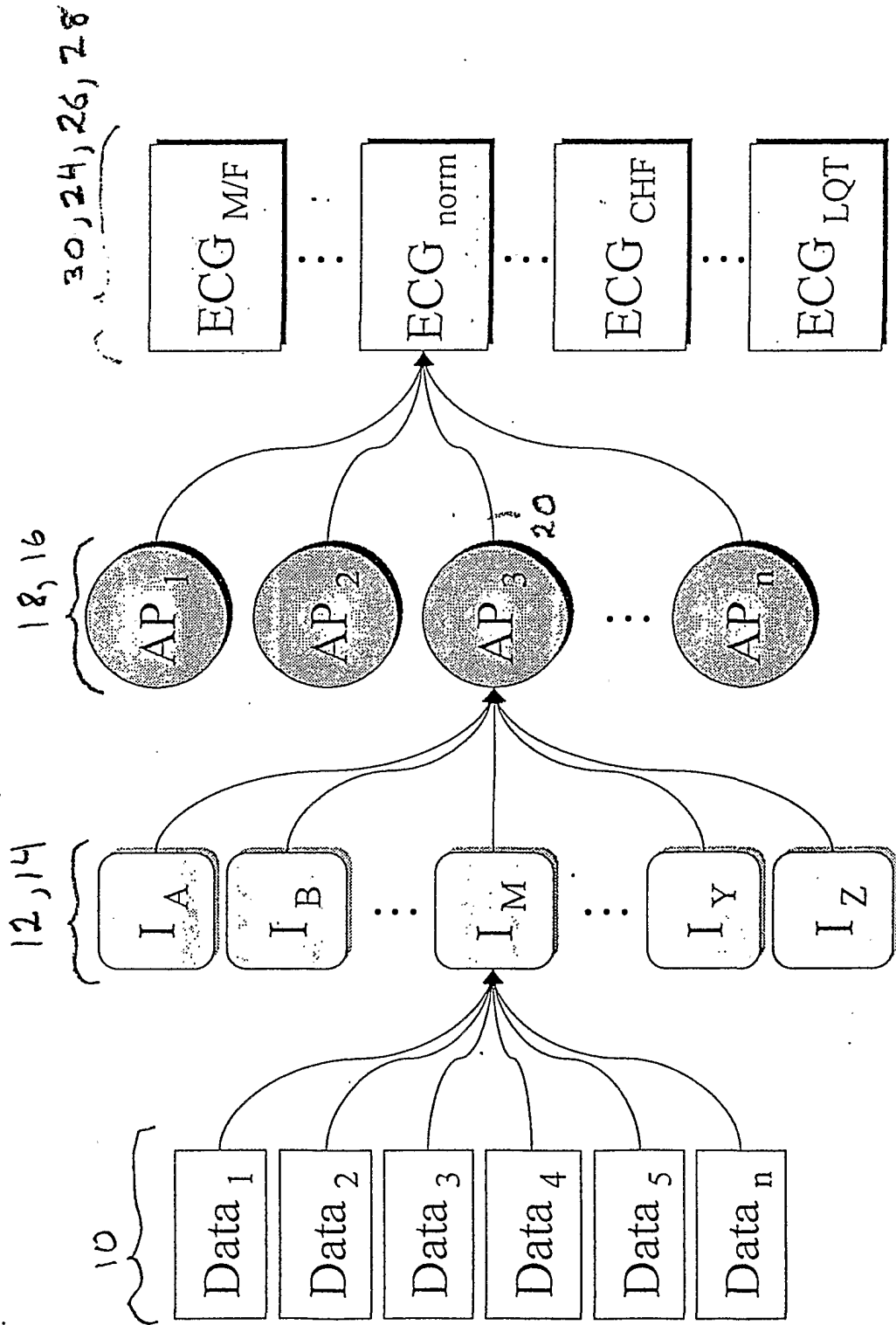

FIG. 1B



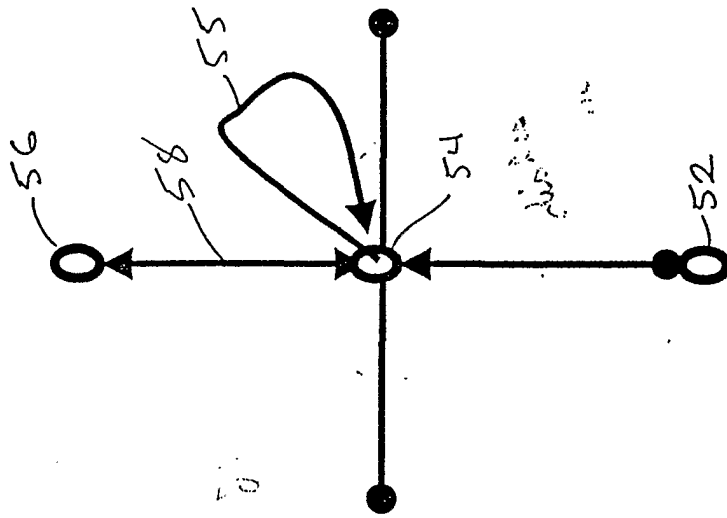
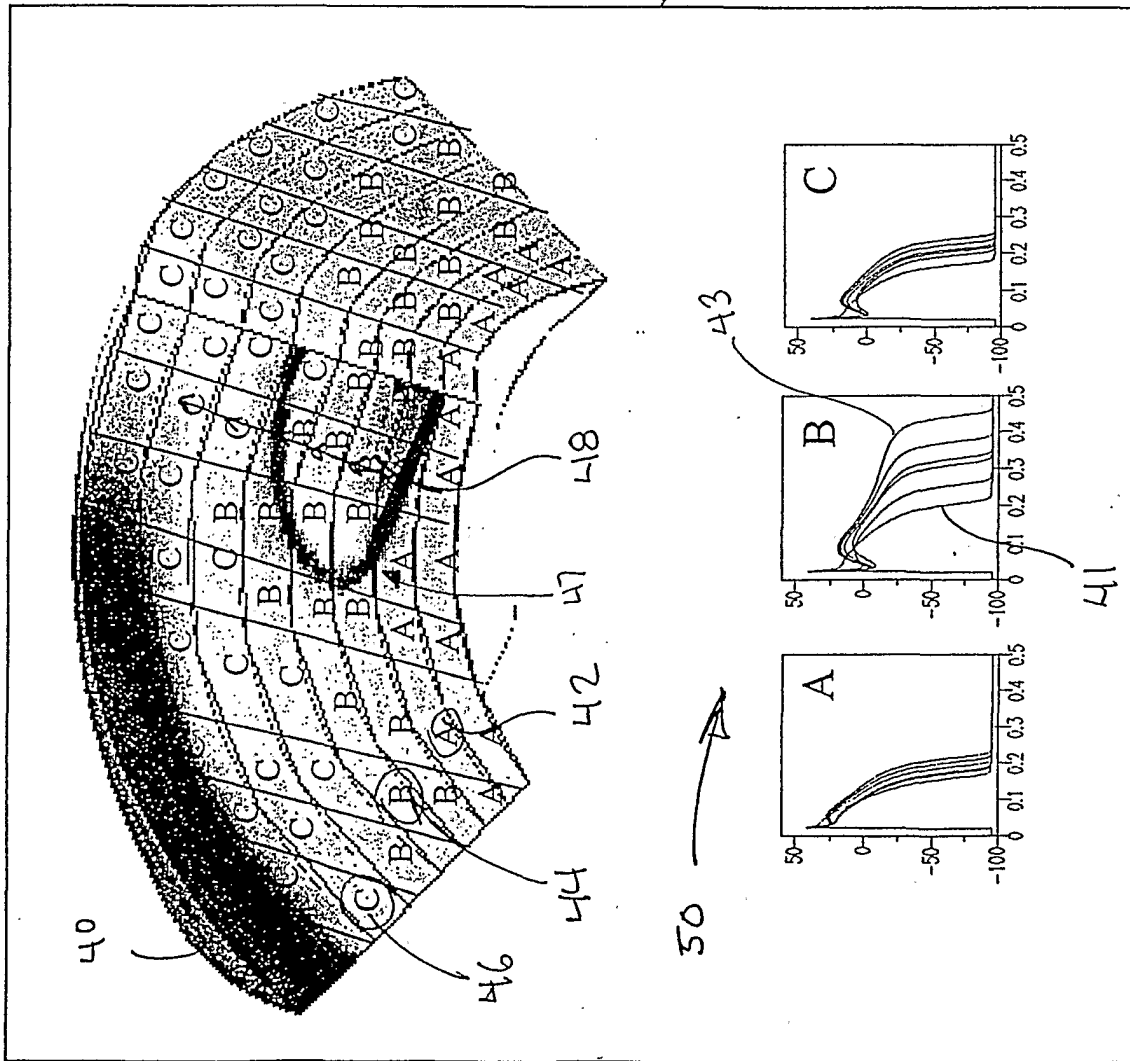
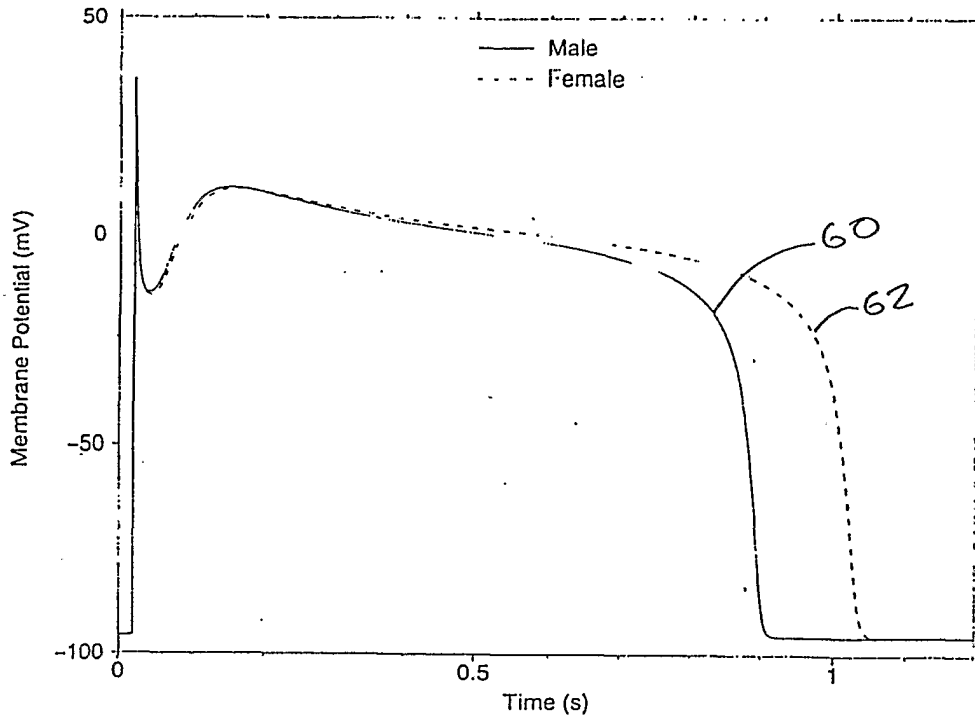

FIG. 3

A. Action Potential



3A

B. Ito

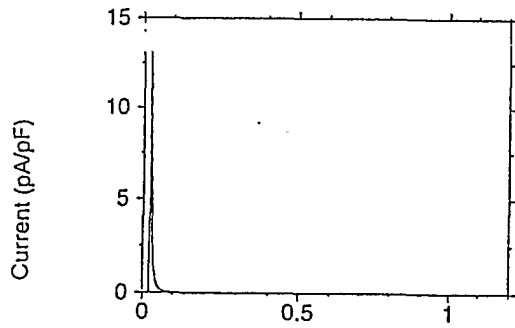

C. IKr

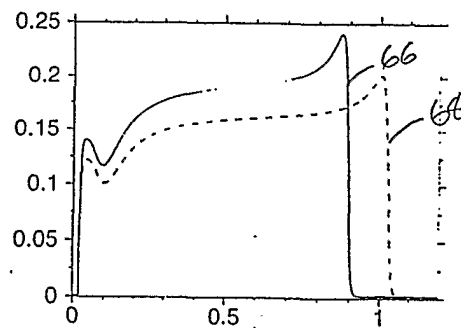

D. IK1

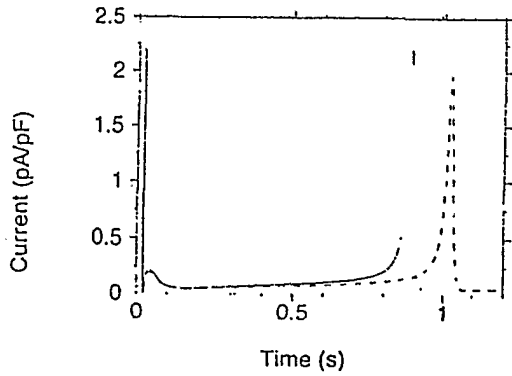

E. IKs

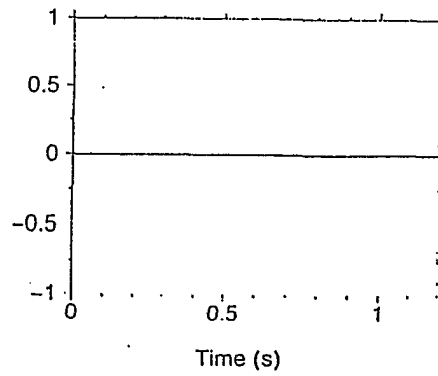

3B

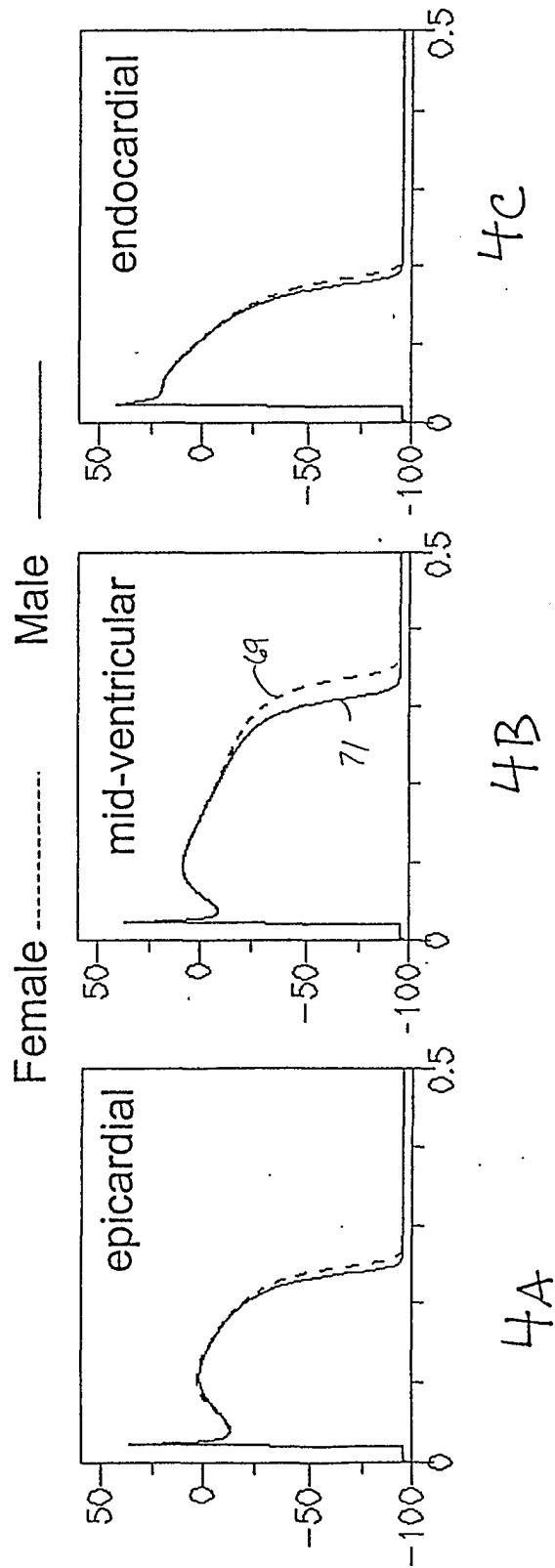

FIG. 4

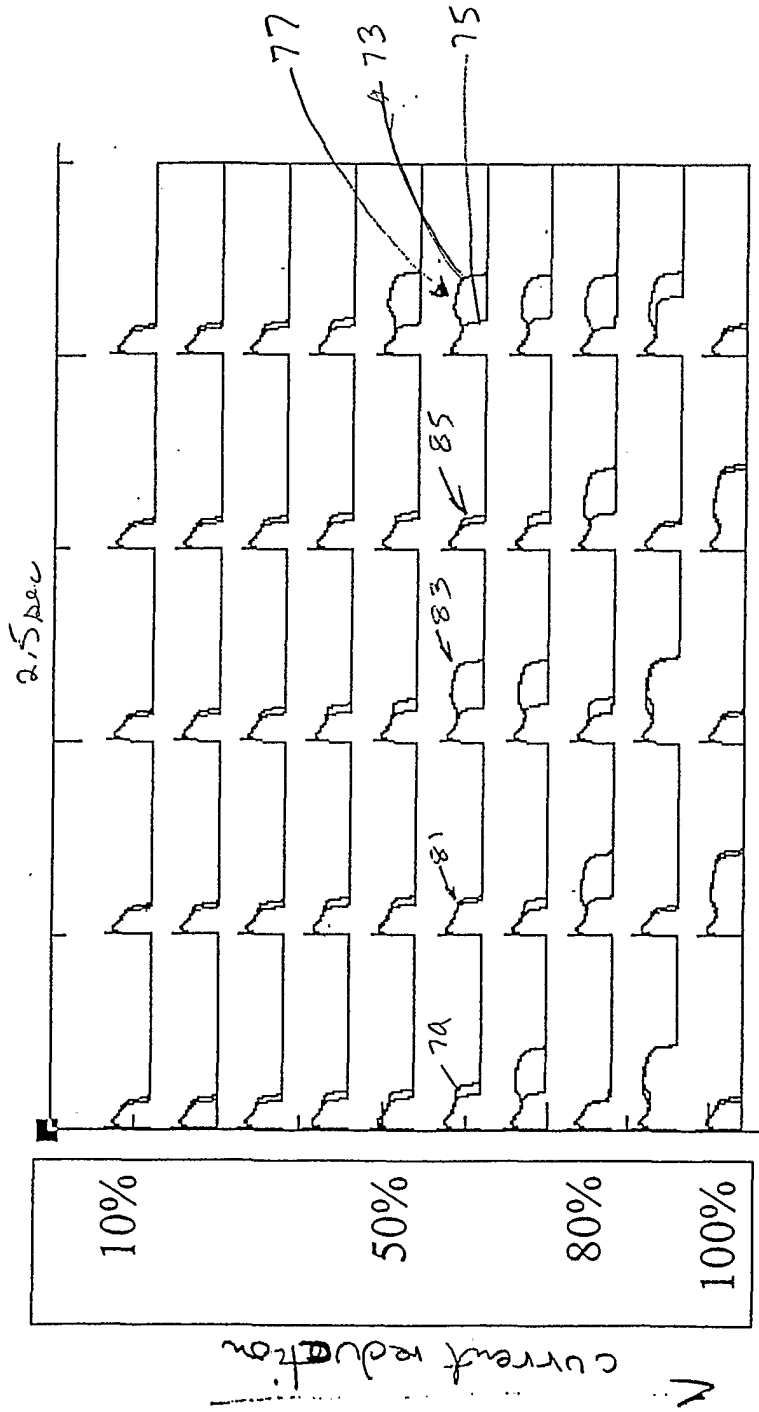
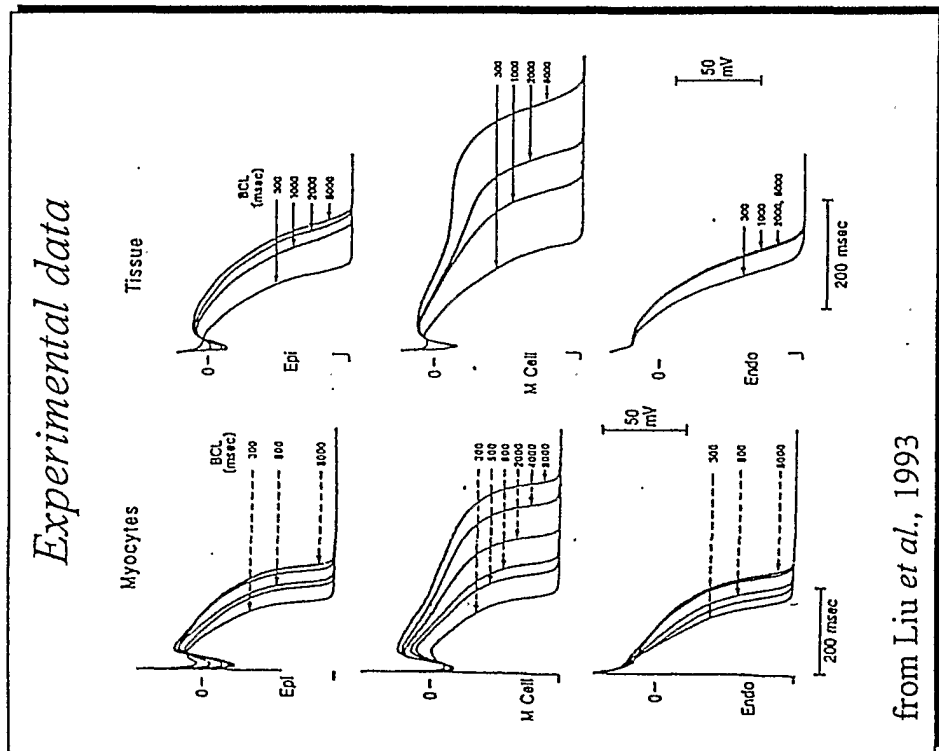

FIG. 5

FIG. 6

6A



6B

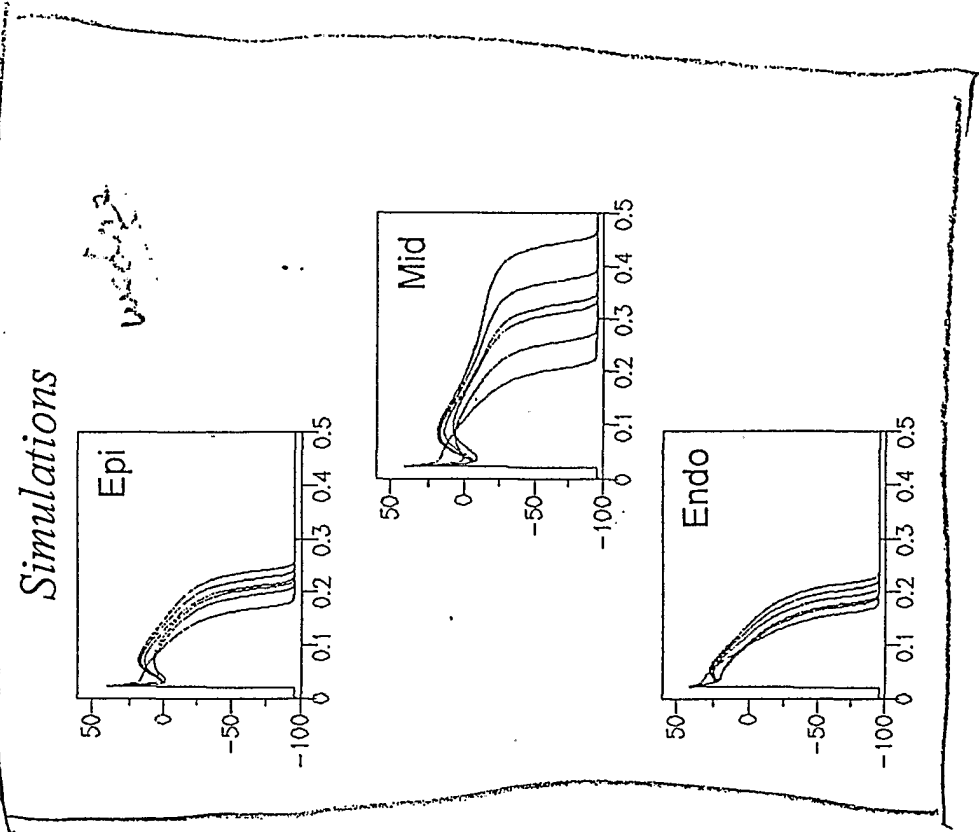

from Liu et al., 1993

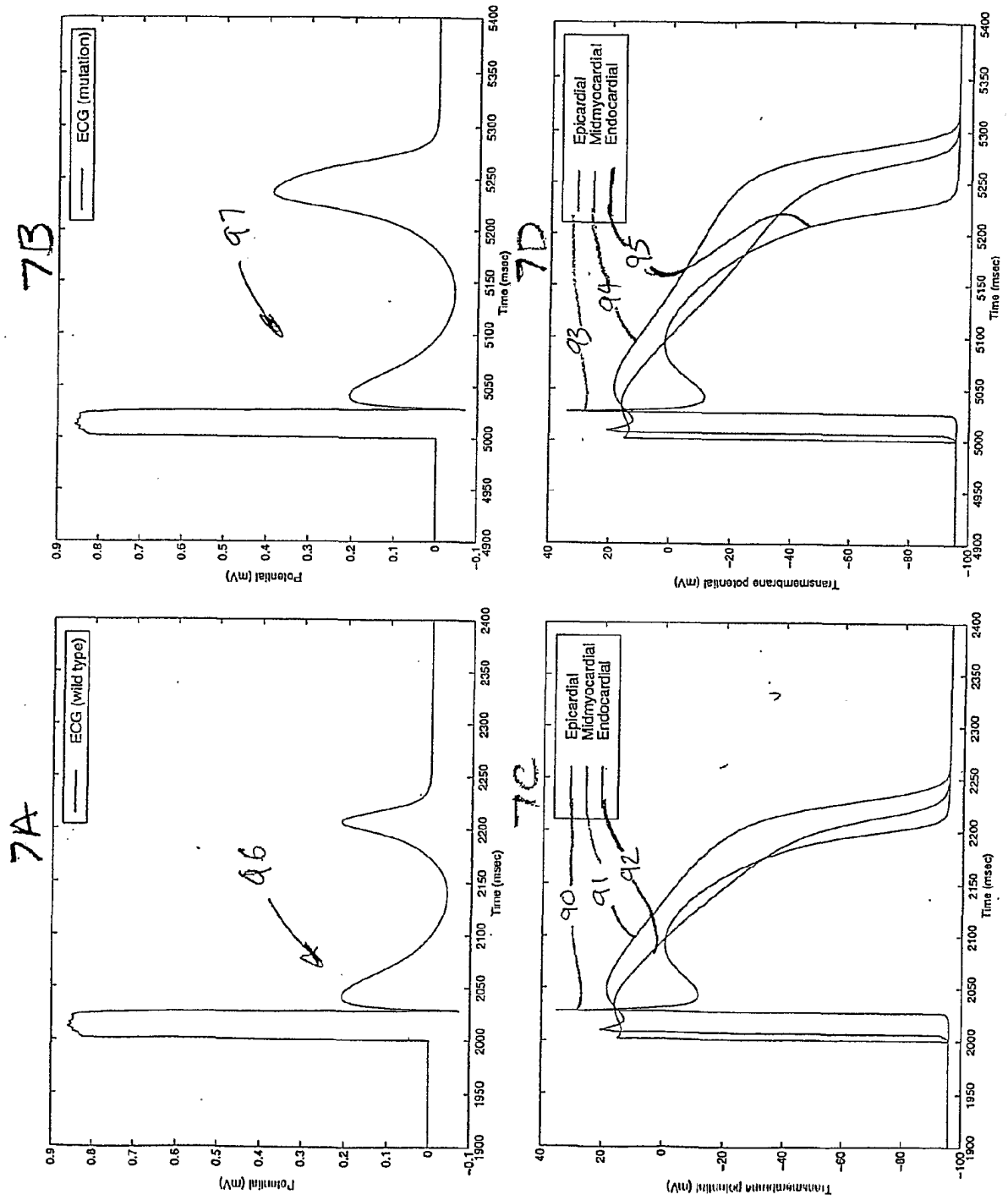

FIG. 7

专利名称(译)	用于模拟器官中蛋白质表达的计算系统		
公开(公告)号	EP1311972A2	公开(公告)日	2003-05-21
申请号	EP2001946650	申请日	2001-06-22
[标]申请(专利权)人(译)	PHYSIOME SCI		
申请(专利权)人(译)	PHYSIOME科学, INC.		
当前申请(专利权)人(译)	PHYSIOME科学, INC.		
[标]发明人	COLATSKY THOMAS J MUZIKANT ADAM L ROUNDS DONNA RICE JOHN JEREMY		
发明人	COLATSKY, THOMAS, J. MUZIKANT, ADAM, L. ROUNDS, DONNA RICE, JOHN, JEREMY		
IPC分类号	G01N33/48 A61B5/00 G01N33/68 G06F17/13 G06F19/00 G06F17/00		
CPC分类号	G16H50/50		
优先权	09/599128 2000-06-22 US		
外部链接	Espacenet		

摘要(译)

公开了器官的计算模型以及用于评估在包括器官的单个细胞中发生的遗传差异的微观和整个器官影响的过程。模型中的遗传差异基于蛋白质功能的变化或与基因表达模式中基因突变, 性别, 疾病或基于等位基因的变异相关的分布。