



(11) **EP 1 084 676 B1**

(12) **EUROPEAN PATENT SPECIFICATION**

(45) Date of publication and mention of the grant of the patent:  
**25.04.2007 Bulletin 2007/17**

(51) Int Cl.:  
**A61B 5/05<sup>(2006.01)</sup> A61B 5/00<sup>(2006.01)</sup>**  
**A61B 10/00<sup>(2006.01)</sup>**

(21) Application number: **00119415.8**

(22) Date of filing: **12.09.2000**

(54) **Apparatus making decision on the monthly physiological condition of a femal body**

Entscheidungsfindungsgerät für die monatliche physiologische Kondition eines weiblichen Körpers

Appareil de prise de décision mensuelle pour un corps femelle

(84) Designated Contracting States:  
**DE ES FR GB IT**

(30) Priority: **13.09.1999 JP 25853899**

(43) Date of publication of application:  
**21.03.2001 Bulletin 2001/12**

(73) Proprietor: **TANITA CORPORATION**  
**Tokyo (JP)**

(72) Inventors:  
• **Kodama, Miyuki**  
**Itabashi-ku,**  
**Tokyo (JP)**

• **Sato, Hitoshi**  
**Itabashi-ku,**  
**Tokyo (JP)**

(74) Representative: **Müller-Boré & Partner**  
**Patentanwälte**  
**Grafinger Strasse 2**  
**81671 München (DE)**

(56) References cited:  
**EP-A- 0 339 092 EP-A- 0 344 770**  
**EP-A- 0 498 303 US-A- 4 784 155**  
**US-A- 5 499 631**

**EP 1 084 676 B1**

Note: Within nine months from the publication of the mention of the grant of the European patent, any person may give notice to the European Patent Office of opposition to the European patent granted. Notice of opposition shall be filed in a written reasoned statement. It shall not be deemed to have been filed until the opposition fee has been paid. (Art. 99(1) European Patent Convention).

**Description**

Field of the Invention:

5 **[0001]** The present invention relates to a use of an apparatus for making a decision on the monthly physiological condition of a female body, such as ovulation, PMS (premenstrual syndrome), menstruation, fertilizable condition or other female physical conditions which appear in a monthly cycle. Also, it relates to an apparatus which makes a decision on the monthly physiological condition of a female body, and an apparatus which produces some useful data in making such a decision.

10 Prior Art:

**[0002]** As seen from Fig.1, the monthly physiological condition of a female body is closely related with the basal body temperature as for instance follows: the basal body temperature transfers from the low temperature phase to the high temperature phase on the day of ovulation, and from the high temperature phase to the low temperature phase on the menstruation start day. Women, therefore, measure their basal body temperature with a gynecological thermometer for the purpose when they wake up every morning, so that a record of basal body temperature may be prepared for making a required decision on their physiological conditions.

20 Problems to be solved by the invention:

**[0003]** It, however, takes about five or more minutes to measure their basal body temperature while they lay in bed every day without moving. This is bothersome more or less, and they are apt to fall a sleep before without knowing it, sometimes even oversleeping.

25 **[0004]** Also, the record of basal body temperature makes it possible as described above to determine only some of physiological condition of a female body, which are usually used for birth control, such as ovulation, menstruation or fertilizable condition. A decision as to whether or not they are suffering PMS cannot be made from the record of basal body temperature. Nowadays women have been increasingly interested in the adverse effect on their daily lives caused by PMS, which are likely to start seven days earlier than the start of menstruation. Some examples of such adverse effect are: headache, restlessness, abdominal pain, edema or other unpleasing condition. As a psychological treatment for PMS their realizing that they are put in condition of "PMS" can reduce effectively their sufferings.

30 **[0005]** EP 0 498 303 A1 discloses a method for determining the fertile and infertile periods in the monthly cycle of females and a device for carrying out such measurements. In the described method a probe is inserted into the vagina for measuring the interface impedance.

35 **[0006]** It is the object of the invention to provide an apparatus which produces some data for making a decision on the monthly physiological condition of a female body which is easy to use.

**[0007]** This object is fulfilled by an apparatus having the features disclosed in claim 1. Preferred embodiments are defined in the dependent claims.

40 **[0008]** Preferably, the apparatus which produces some data for making a decision on the monthly physiological condition of a female body comprises: a bioelectric impedance meter; a weight meter; a processor which makes a modification of each bioelectric impedance in terms of the weight; a weight-modified bioelectric impedance memory which stores a historical record of weight-modified bioelectric impedance, and a display having a function of showing the historical record of weight-modified bioelectric impedance, representing how it has been varying.

**[0009]** Said display has another function of showing the present weight of the female body.

45 **[0010]** The apparatus may further comprise a temperature meter and a temperature memory which stores a historical record of temperature, said display having another function of showing the historical record of temperature, representing how it has been varying.

**[0011]** The apparatus may further comprise an arithmetic unit which determines the body fat percentage in terms of the bioelectric impedance, said display having another function of showing the body fat percentage thus determined.

50 **[0012]** Preferably, the apparatus which makes a decision on the monthly physiological condition of a female body comprises: a bioelectric impedance meter; a bioelectric impedance memory which stores a historical record of bioelectric impedance; a decision making unit which makes a required decision by comparing the present bioelectric impedance with the historical record of bioelectric impedance; and a display which has a function of showing the result of the decision thus made.

55 **[0013]** The apparatus comprises a weight meter, said display having another function of showing the present weight of the female body.

**[0014]** The apparatus may further comprise a temperature meter and a temperature memory which stores a historical record of temperature, thus permitting said decision making unit to make a required decision by comparing the present

temperature with the historical record of temperature in addition to the comparison of the present bioelectric impedance with the historical record of bioelectric impedance.

5 [0015] Preferably the apparatus which makes a decision on the monthly physiological condition of a female body comprises: a bioelectric impedance meter; a weight meter; a processor which makes a modification of each bioelectric impedance in terms of the weight; a weight-modified bioelectric impedance memory which stores a historical record of weight-modified bioelectric impedance; a decision making unit which makes a required decision by comparing the present weight-modified bioelectric impedance with the historical record of weight-modified bioelectric impedance; and a display which has a function of showing the result of the decision thus made.

[0016] Said display has another function of showing the present weight of the female body.

10 [0017] The apparatus may further comprise a temperature meter and a temperature memory which stores a historical record of temperature, thus permitting said decision making unit to make a required decision by comparing the present temperature with the historical record of temperature in addition to the comparison of the present weight-modified bioelectric impedance with the historical record of weight-modified bioelectric impedance.

[0018] Said monthly physiological condition of the female body may pertain to the PMS.

15 [0019] The apparatus may further comprise an input device which inputs extra data pertaining to the menstrual period, thus permitting said decision making unit to take such extra data into account.

[0020] Said extra data may include the starting date of the menstrual period and/or the ending date of the menstrual period.

20 [0021] Said display may have another function of showing an advisory message pertaining to the decision on the monthly physiological condition.

[0022] Said advisory message may include advise pertaining to the manner of living, including dieting.

[0023] The apparatus may further comprise an arithmetic unit which determines a body fat percentage in terms of the bioelectric impedance, said display having another function of showing the body fat percentage thus determined.

25 Brief Description of the Drawings:

[0024] Other objects and advantages of the present invention will be understood from the following description of some preferred embodiments, which are shown in accompanying drawings:

30 Fig.1 illustrates how basal body temperature, secretion of hormones (ordinate) and the monthly physiological condition of a female body vary with time (abscissa);

Fig.2 illustrates how the BI and the basal body temperature (ordinate) vary with time (abscissa);

Fig.3 shows how the weight (ordinate) varies with time (abscissa);

Fig.4 shows how the BI (ordinate) is correlated with the weight (abscissa);

35 Fig.5 shows how the weight-modified BI and the basal body temperature (ordinate) vary with time (abscissa);

Fig.6 shows how the weight-modified BI (ordinate) is correlated with the basal body temperature(abscissa);

Fig.7 illustrates how the weight-modified BI, the basal body temperature (ordinate) and the monthly physiological condition of a female body vary with time (abscissa);

40 Fig.8 illustrates how the weight-modified BI (ordinate), the basal body temperature and the monthly physiological condition of a female body vary with time (abscissa);

Fig.9 is a frontal view of an apparatus which makes a decision on the monthly physiological condition of a female body according to a first embodiment of the present invention;

Fig.10 illustrates the arrangement of major elements of the decision making apparatus of Fig.9;

45 Fig.11 is a flowchart illustrating a series of actions for making a decision on the monthly physiological condition of a female body; and

Fig.12 is a perspective view of a decision making apparatus according to a second embodiment of the present invention.

Detailed Description of the Invention:

50 [0025] Before entering the description of the present invention the relation between the monthly physiological condition of a female body and the bioelectric impedance (hereinafter referred to as "BI") of the female body is described.

55 [0026] After making similar tests repeatedly on a plurality of subjects or female bodies, the inventor found that the BI is correlated closely with the monthly physiological condition, and he had the idea of using the correlation therebetween in making a decision on the monthly physiological condition of a female body. Some accompanying drawings (Figs. 1 to 8) show examples of measurements , which were conducted on a selected subject when waking up every morning. As for the BI of the subject it appeared between two selected points on the subject's both feet.

[0027] Fig.2 shows how the BI and the basal body temperature change cyclically. Specifically the curves of the BI and

the basal body temperature are given by plotting the averages of every two adjacent measurements according to the method of moving averages. As a general tendency both the BI and the basal body temperature vary cyclically, the correlation between these respective cyclical variations being as follows: the basal body temperature remains at low values (called "low temperature phase") while the BI remains at high values, the BI remains at low values while the basal body temperature remains at high values (called "high temperature phase"), and the sudden rise and fall of the BI appear for the relatively short length of time beginning with the start of premenstruum and ending with the end of the first half of the following menstrual period.

**[0028]** Now, the correlation between the weight and the BI of the selected subject is described by referring to data shown Figs.3 and 4. While the measurement was conducted on the selected subject the weight continued to change gradually with time, as seen from Fig.3. Fig.4 shows how the BI is correlated with the weight. It can be seen that there is a significant negative correlation between the BI and the weight (the correlation coefficient "R" being equal to 0.527). Specifically the BI increases as the weight decreases, or the BI reduces as the weight increases. Such correlation may be justly considered to come from the findings or confirmed facts of: first, the water content of the body increasing in proportion to the increase of the weight; and second, the BI decreasing in proportion to the increase of the water content of the body. From this recognition it is concluded that the BI graph of Fig.2 be affected more or less by the continuous change of the weight as seen from Fig.3. To provide a correct graphic representation, therefore, it is necessary to modify the BI graph of Fig.2 with the weight.

**[0029]** Fig.5 is a graph of Fig.2 modified with weight, showing that the weight-modified BI and the basal body temperature change cyclically. The measured BI can be modified with the weight by adding to the measured BI the decrement of BI which is proportional inversely to the increment of weight or by subtracting from the measured BI the increment of the BI which is proportional inversely to the decrement of the weight, thus eliminating the influence on the graphic representation by the continuous change of the weight. Such weight-modified BI can be calculated from the following equation 1 or 2:

$$\text{weight-modified BI} = \text{BI} + A \times \text{difference of weight from the first weight} \quad (1)$$

or

$$\text{weight-modified BI} = \text{BI} + B \times \text{difference of weight from the preceding weight} \quad (2),$$

where A and B stand for modification coefficients. Comparison with Fig. 2 reveals that the graphic representation of Fig. 5 is conspicuous by its cyclic change of the BI, which curve is now free of the influence by the weight change.

**[0030]** Next, the manner in which the BI, the basal body temperature and the PMS are correlated is described. As seen from Figs.2 and 5, in general, the BI exhibits high values during the low temperature phase, and exhibits low values during the high temperature phase. As a noticeable change, the BI exhibits low values for the extra period beginning with the start of the premenstruum and ending with the end of the first half of the following menstrual period. The extra period is a substantial part of the low temperature phase of the basal body temperature. In the low temperature phase there appear two peaks and the intervening valley point in the BI curve, implying that the basal body temperature is not substantially correlated with the BI. The least correlation between the basal body temperature and the BI can be confirmed from Fig.6 (correlation coefficient  $R=0.424$ ).

**[0031]** Low values of the BI appearing for the extra period of the low temperature phase may be justly attributable to the fact that the female body contains as much water as the edema appears, the edema is getting worse as the water content increases, and accordingly the BI decreases. Thus, the BI appears to be closely related with the edema: the BI exhibits low values when the edema appears, and the BI exhibits high values when the edema disappears. Observation of the BI over an elongated term permits the making of a decision on the subject suffering from the edema. Such decision has been hitherto impossible so far as the measurement of the basal body temperature is used. Also, it is well known that the edema appearing in the premenstruum has a close connection with PMS: the edema is getting worse, and the PMS is getting worse in unison. This suggests that a decision on the suffering from PMS be made on the basis of the continuous change of the BI.

**[0032]** Next, reference is made to Figs.7 and 8, describing the relation between the weight-modified BI (or the BI) and the monthly physiological condition of the selected female body. These figures definitely show that the weight-modified BI curve varies cyclically, and that it is so related with the monthly physiological condition of the female body that a decision on the monthly physiological condition of the female body may be made on the basis of the continuous change of the weight-modified BI curve. Specifically the high-to-low value transition of weight-modified BI appearing at the

boundary between the low temperature phase and the high temperature phase indicates that the ovulation has occurred. The high-to-low value transition of weight-modified BI is followed by the level off-and-sudden rise of the weight-modified BI. The sudden rise shows entrance into the premenstruum, indicating that the edema and the PMS appear soon. The sudden rise is followed by the sudden fall, which indicates the start of menstruation. The sudden fall is followed by the gradual rise-and-level off. The gradual rise indicates the end of PMS, and the beginning of the level-off indicates the end of menstruation.

**[0033]** The same inclination as described above with respect to one selected subject was observed in each of the other subjects, and may be presumably observed in women in general. In the experiments the BI appearing between two selected points on both feet of each subject was measured. Other BIs measured between two points selected on a female body can be used equally, but the BI appearing between two selected points on both feet shows a clearly discernible cyclic change compared with other BIs, thus facilitating the making of a decision on physiological condition of a female body.

**[0034]** Now, an apparatus which makes a decision on the monthly physiological condition of a female body according to a first embodiment of the present invention is described.

**[0035]** Referring to Fig.9 the decision making apparatus comprises a weighing scale type of bioelectric impedance meter 20, and a control box 40 connected to the bioelectric impedance meter 20 via a cable 30. Instead of the cable 30, wireless communication such as infrared communication may be used.

**[0036]** The bioelectric impedance meter 20 has a pair of constant-current applying electrodes 21a and 21b and a pair of voltage measuring electrodes 22a and 22b applied to its top surface. The control box 40 has a display screen 42a on its front. The display screen 42a includes an advisory message display area 42b. On the front of the control box 40 there appear a set of operation keys, including a power switch 41a, a measurement-start-command inputting key 41b, a scroll-up key 41c, a scroll-down key 41d, a menstruation-start-day inputting key 41 e, and a menstruation-end-day inputting key 41f.

**[0037]** Fig.10 illustrates the arrangement of major elements of the decision making apparatus of Fig.9. As shown, the bioelectric impedance meter 20 comprises: a high-frequency constant current circuit 23 which supplies the pair of constant current applying electrodes 21 a and 21 b with a weak constant current; a voltage measuring circuit 24 which measures the voltage between the opposite voltage measuring electrodes 22a and 22b; a weight meter which measures the weight of a subject 25; and an A/D converter 28 which converts analog voltage-and weight-representative signals in digital form.

**[0038]** The control box 40 comprises a data input device 41 including the operation keys 41a to 41f as described above, a display device 42, a timer 43, a memory 44 and a CPU 45. The display device 42 is capable of showing the measured BI curve, the determined monthly physiological condition, and so forth on its display screen 42a. The timer 43 is used in determining at what time or day the measurement is conducted. The memory 44 stores the measured BIs, the time and date on which a required measurement is made, and so forth. Finally, the CPU 45 makes a decision on the monthly physiological condition of a female body on the basis of the menstrual period data inputted at Steps 10 to 14 (later described), the measured BIs, the weights and other data. Also, the CPU controls the memory 44, the display device 42 and other components in the coordinated way.

**[0039]** Some selected components may be changed in position, as for instance the CPU 45 is shifted to the bioelectric impedance meter 20. The weighing scale type of bioelectric impedance meter 20 may be so designed as to incorporate the control box 40, as in a decision making apparatus according to a second embodiment (later described).

**[0040]** Next, a method of making a decision on the monthly physiological condition is described below by referring to the manner in which the decision making apparatus just described works accordingly.

**[0041]** Fig.11 is a flowchart illustrating a series of actions for making a required decision. At Step 1 a subject depresses the power switch 41a to turn the decision making apparatus 10 on. At Step 2 depression of the measuring switch 41b allows the proceeding to go to Step 3, in which the decision making apparatus is put in the measuring mode. The measuring switch 41b being not depressed, the proceeding is allowed to go to Step 10 in which the decision making apparatus is put in the data-presetting mode in which the menstrual length of time is inputted and recorded for the use of decision making.

**[0042]** At Step 3 the decision making apparatus starts working in the measuring mode. The subject stands on the bioelectric impedance meter 20, the toes and balls of both feet being laid on the opposite constant-current applying electrodes 21a and 21b, and the heels of both feet being laid on the opposite voltage measuring electrodes 22a and 22b. The weight meter 25 is responsive to the weight for measuring it automatically. At Step 4 a weak constant current is directed from the high-frequency constant current circuit 23 to both toes and balls via the opposite constant-current applying electrodes 21a and 21b, thus allowing the constant current to flow between both legs through the abdominal region. Then, the voltage appearing between the opposite voltage measuring electrodes 22a and 22b is determined, and the BI is calculated from the so determined voltage and the current flowing in the abdominal part of the subject. At Step 5 the BI thus obtained is modified according to either equation as described above, thereby normalizing the BI with respect to a given reference value of weight. Thus, the weight-modified BI is free of the influence by the present weight change.

**[0043]** At Step 6 a decision as to which monthly physiological condition of the female body the subject has been in, as for instances, she has been in ovulatory condition or has been suffering from PMS, is made from the present weight-modified BI (as measured at Step 5) and from the record both of the previous weight-modified BI and the menstrual lengths of time (retrieved from the memory 44) in the light of the correlation between the weight modified BI curve and the monthly physiological condition of a female body. At Step 7 the weight modified BI curve and other data appear in the display screen 42a. Specifically, the so made decision and the advisory message pertaining thereto appear on the advisory display area 42b. Some examples of the decisions appearing in the display are: physical conditions such as ovulation, PMS, menstruation, fertilizable condition, and edema, and accompanying mental conditions such as a feeling of unhealthy condition or of restlessness. As one example of the advisory message the manner of living, including dieting is advised as for instance follows:

"you are involved in premenstruum, so that you may suffer from PMS and edema. Calm yourself lest you should be impatient. Take Vitamin B rich foods.";

"You are in menstrual period. You will get rid of the unpleasant condition soon. Take enough iron lest you should be anemia.";

"Menstrual period has finished, and you are now in the best physical condition. You had better take good exercise."; or  
 "You are involved in the ovulatory period, and you are pleasing less and less. Don't overeat yourself."

**[0044]** At Step 8 the weight-modified BI, the weight and so on, which are measured this time, are stored in the memory 44. Subsequently at Step 9 the decision making apparatus 10 turns off automatically, thus finishing the series of measurements.

**[0045]** As described above, if the measuring switch 41b is not depressed at Step 2, the proceeding is allowed to go to Step 10, in which the decision making apparatus is put in the data-presetting mode in which the menstrual length of time is inputted and recorded for use of decision making.

**[0046]** At Step 10 the starting or ending date of the menstrual period is selected by depressing the scroll-up key 41c or the scroll-down key 41d. Assume that the starting date of the menstrual period is selected, and then, at Step 11 the menstruation-start-day inputting key 41e is depressed to allow the proceeding to go to Step 12, where the starting date of the menstrual period selected at Step 10 is stored in the memory 44.

**[0047]** Assume that the ending date of the menstrual period is selected at Step 10, and then, at Step 11 the menstruation-start-day inputting key 41e is not depressed to allow the proceeding to go to Step 13. There, the menstruation-end-day key 41f is depressed to allow the proceeding to go to Step 14, permitting the ending date of the menstrual period to be stored in the memory 44.

**[0048]** Subsequent to the action taken at Step 12 or 14 or in the negative outcome at Step 13 the proceeding goes to Step 9 wherein the decision making apparatus 10 turns off automatically, terminating the inputting of data.

**[0049]** Next, a decision making apparatus according to a second embodiment of the present invention is described. Referring to Fig.12, the decision making apparatus 50 is different from the decision making apparatus 10 of Fig.9 in that: the decision making apparatus 50 has its control box built therein, such a control box 40 being physically separated from the weighing scale type apparatus 20 in Fig.9; and the decision making apparatus 50 permits body temperature to be measured. The decision making apparatus 50 has a pair of constant-current applying electrodes 51a and 51b, a pair of voltage measuring electrodes 52a and 52b, an operation button 53, and a display screen 54 arranged on its top surface. Each constant-current applying electrode 51a or 51b has a temperature measuring sensor 55a or 55b on its front side. The subject can measure her temperature by pinching each sensor between the large and adjacent toes of each foot. Any other temperature meter which measures the temperature of the subject may be used. For example, a measuring-at-ear type of thermometer may be used by communicating with the decision making apparatus 50 via infrared rays. A sublingual measuring type of gynecological thermometer may be used for measurement of the temperature with precision. When a decision is made on the monthly physiological condition of a female body, relying on the BI along with the so measured temperature, such decision is more reliable than that made with recourse to the BI alone.

**[0050]** While embodiments of the present invention have been described above, the present invention should not be understood as being restricted thereto. The BI appearing between two selected points on both feet is measured in the above embodiments, but the BI appearing elsewhere may be measured, for example between two selected points on both hands, or either hand and either foot.

**[0051]** The decision making apparatus may be so modified as to permit an access to the memory for retrieving some data pertaining to a selected subject among others, thereby allowing a plurality of subjects to use one and same decision making apparatus in common.

**[0052]** Also, the decision making apparatus may be so modified as to determine the body fat percentage in terms of the measured BI, showing it in the display. Furthermore, the body temperature, the weight and other factors used in making a decision on the monthly physiological condition of a female body may be displayed. This single decision making apparatus thus modified can perform a variety of functions useful for healthcare, including those functions which have

been performed hitherto by different conventional apparatuses such as a weighing scale, a thermometer and a body fat meter.

Advantages:

5  
 [0053] As may be understood from the above, the decision making method and apparatus the BI as the major factor can make a required decision much quicker and easier than the conventional method and apparatus using the body temperature as the major factor, taking say several seconds to several tens of seconds. Also, there is no worry about falling a sleep unconsciously as would often occur in the conventional way wherein the subject needs to lay in bed without moving only for the sake of measuring one's basal body temperature. In contrast the BI can be measured while the subject is standing. Thanks to use of the BI as the major factor the decision making method and apparatus can be applied to diagnoses of PMS. Thus, the decision making method and apparatus facilitate a woman's daily healthcare as well as birth control, which the application of the conventional method and apparatus has been limited to.

10  
 [0054] The reliability of the decision making can be improved by adding extra factors of weight and body temperature to the major factor of BI. Still another advantage of the decision making apparatus is that it can be modified to display the body temperature or the weight or to determine the body fat percentage in terms of the measured BI to be able to display this information, whereby this single apparatus alone can perform a variety of functions useful for healthcare, including those functions which have been performed hitherto by different conventional apparatuses such as a weighing scale, a thermometer and a body fat meter.

20  
**Claims**

25  
 1. An apparatus which produces some data for making a decision on the monthly physiological condition of a female body comprising:

30  
 a bioelectric impedance meter (20) comprising a pair of constant-current applying electrodes (21 a, 21 b; 51 a, 51 b) and a pair of voltage measuring electrodes applied to its top surface (22a, 22b; 52a, 52b) which can be applied to the outer layer of the skin of the female body, said a bioelectric impedance meter (20) being suitable for measuring the bioelectric impedance appearing between said pairs of electrodes (21 a, 21b, 22a, 22b; 51a, 51b, 52a, 52b);

35  
 a bioelectric impedance memory (44) which stores a historical record of bioelectric impedance;  
 a display (42; 54) which has a function of showing the historical record of bioelectric impedance, representing how it has been varying; **characterized in that** the apparatus further comprises a weight meter (25),  
 said display (42; 54) having another function of showing the present weight of the female body.

40  
 2. An apparatus which produces some data for making a decision on the monthly physiological condition of a female body according to claim 1 wherein it further comprises:

45  
 a processor (45) which makes a modification of each bioelectric impedance in terms of the weight; and  
 a weight-modified bioelectric impedance memory (44) which stores a historical record of weight-modified bioelectric impedance;  
 said data shown by said display (42; 54) representing how said historical record of weight-modified bioelectric impedance has been varying.

50  
 3. An apparatus which produces some data for making a decision on the monthly physiological condition of a female body according to claim 1 or 2, wherein it further comprises a temperature meter (55a, 55b) and a temperature memory (44) which stores a historical record of temperature, said display (54) having another function of showing the historical record of temperature, representing how it has been varying.

55  
 4. An apparatus which produces some data for making a decision on the monthly physiological condition of a female body according to any of claims 1 to 3, wherein it further comprises an arithmetic unit which determines the body fat percentage in terms of the bioelectric impedance, said display (42; 54) having another function of showing the body fat percentage thus determined.

5. An apparatus which makes a decision on the monthly physiological condition of a female body according to claim 1 wherein it further comprises:

a decision making unit (45) which makes a decision on the condition of the female body by comparing the present bioelectric impedance with the historical record of bioelectric impedance;  
said display (42; 54) having another function of showing the result of the decision thus made.

5 6. An apparatus which makes a decision on the monthly physiological condition of a female body according to claim 5 wherein it further comprises a temperature meter (55a, 55b) and a temperature memory (44) which stores a historical record of temperature, thus permitting said decision making unit (45) to make a required decision by comparing the present temperature with the historical record of temperature in addition to the comparison of the present bioelectric impedance with the historical record of bioelectric impedance.

10 7. An apparatus which makes a decision on the monthly physiological condition of a female body according to claim 1 wherein it further comprises:

15 a processor (45) which makes a modification of each bioelectric impedance in terms of the weight;  
a weight-modified bioelectric impedance memory (44) which stores a historical record of weight-modified bioelectric impedance; and  
a decision making unit (45) which makes a decision on the condition of the female body by comparing the present weight-modified bioelectric impedance with the historical record of weight-modified bioelectric impedance; and  
20 said display (42; 54) having another function of showing the result of the decision thus made.

25 8. An apparatus which makes a decision on the monthly physiological condition of a female body according to claim 7, wherein it further comprises a temperature meter (55a, 55b) and a temperature memory (44) which stores a historical record of temperature, thus permitting said decision making unit (45) to make a decision on the condition of the female body by comparing the present temperature with the historical record of temperature in addition to the comparison of the present weight-modified bioelectric impedance with the historical record of weight-modified bioelectric impedance.

30 9. An apparatus which makes a decision on the monthly physiological condition of a female body according to any of claims 5 to 8, wherein said monthly physiological condition of the female body pertains to the PMS.

35 10. An apparatus which makes a decision on the monthly physiological condition of a female body according to any of claims 5 to 8, wherein it further comprises an input device (41) which inputs extra data pertaining to the menstrual period, thus permitting said decision making unit (45) to take such extra data into account.

11. An apparatus which makes a decision on the monthly physiological condition of a female body according to claim 10, wherein said extra data includes the starting date of the menstrual period and/or the ending date of the menstrual period.

40 12. An apparatus which makes a decision on the monthly physiological condition of a female body according to any of claims 5 to 11, wherein said display (42; 54) has another function of showing an advisory message pertaining to the decision on the monthly physiological condition.

45 13. An apparatus which makes a decision on the monthly physiological condition of a female body according to claim 12, wherein said advisory message includes advice pertaining to the manner of living, including dieting.

50 14. An apparatus which makes a decision on the monthly physiological condition of a female body according to any of claims 5 to 13, wherein it further comprises an arithmetic unit which determines a body fat percentage in terms of the bioelectric impedance, said display (42; 54) having another function of showing the body fat percentage thus determined.

### Patentansprüche

55 1. Vorrichtung, welche einige Daten zum Durchführen einer Entscheidung über den monatlichen physiologischen Zustand eines weiblichen Körpers erzeugt, umfassend:

einen bioelektrischen Impedanz- bzw. Widerstandsmesser (20), der ein Paar Konstant- bzw. Dauerstrom an-

wendende Elektroden (21a, 21 b; 51 a, 51 b) und ein Paar auf seiner Oberseite angebrachte spannungsmessende Elektroden (22a, 22b; 52a, 52b) umfasst, die auf die äußere Schicht der Haut des weiblichen Körpers aufgesetzt bzw. angebracht werden können, wobei der bioelektrische Impedanz- bzw. Widerstandsmesser (20) zum Messen der bioelektrischen Impedanz bzw. des bioelektrischen Widerstandes geeignet ist, die bzw. der zwischen den Elektrodenpaaren (21 a, 21 b, 22a, 22b; 51 a, 51 b, 52a, 52b) auftritt; einen bioelektrischen Impedanz- bzw. Widerstandsspeicher (44), der die bisher gemessenen bioelektrischen Impedanz- bzw. Widerstandswerte bzw. eine historische Aufstellung von bioelektrischer Impedanz speichert; ein Display bzw. eine Anzeige (42; 54) mit der Funktion, die bisher gemessenen bioelektrischen Impedanz- bzw. Widerstandswerte anzuzeigen und darzustellen, wie sie sich verändert haben bzw. verändern;

**dadurch gekennzeichnet** das die Vorrichtung weiter umfasst

einen Gewichtsmesser bzw. eine Waage (25),

das Display bzw. die Anzeige (42; 54) eine weitere Funktion des Anzeigens des gegenwärtigen bzw. momentanen Gewichts des weiblichen Körpers aufweist.

2. Vorrichtung, welche einige Daten zum Durchführen einer Entscheidung über den monatlichen physiologischen Zustand eines weiblichen Körpers erzeugt, nach Anspruch 1, wobei sie ferner umfasst:

einen Prozessor (45), der eine Modifikation jeder bioelektrischen Impedanz bzw. jedes bioelektrischen Widerstandes bezüglich des Gewichts vornimmt; und

einen gewichtsmodifizierten bioelektrischen Impedanz- bzw. Widerstandsspeicher (44), der die bisher gemessenen gewichtsmodifizierten bioelektrischen Impedanz- bzw. Widerstandswerte bzw. eine historische Aufstellung von gewichtsmodifizierter bioelektrischer Impedanz speichert;

die vom Display bzw. der Anzeige (42; 54) angezeigten Daten, die darstellen, wie sich die bisher gemessenen gewichtsmodifizierten bioelektrischen Impedanz- bzw. Widerstandswerte verändert haben bzw. verändern.

3. Vorrichtung, welche einige Daten zum Durchführen einer Entscheidung über den monatlichen physiologischen Zustand eines weiblichen Körpers erzeugt, nach Anspruch 1 oder 2, wobei sie ferner einen Temperaturmesser (55a, 55b) und einen Temperaturspeicher (44) umfasst, welcher die bisher gemessenen Temperaturwerte bzw. eine historische Aufstellung der Temperatur speichert, wobei das Display bzw. die Anzeige (54) eine weitere Funktion des Anzeigens der bisher gemessenen Temperaturwerte, die darstellen, wie sich die Temperatur verändert hat bzw. verändert.

4. Vorrichtung, welche einige Daten zum Durchführen einer Entscheidung über den monatlichen physiologischen Zustand eines weiblichen Körpers erzeugt, nach einem der Ansprüche 1 bis 3, wobei sie ferner eine arithmetische Einheit umfasst, die den Körperfettprozentatz bezüglich der bioelektrischen Impedanz bzw. des bioelektrischen Widerstandes bestimmt, wobei das Display bzw. die Anzeige (42; 54) eine weitere Funktion des Anzeigens des so bestimmten Körperfettprozentatzes aufweist.

5. Vorrichtung, welche eine Entscheidung über den monatlichen physiologischen Zustand eines weiblichen Körpers durchführt, nach Anspruch 1, wobei sie ferner umfasst:

eine Entscheidungsfindungs- bzw.-durchführungseinheit (45), die durch Vergleichen der gegenwärtigen bzw. momentanen bioelektrischen Impedanz bzw. des bioelektrischen Widerstandes mit den bisher gemessenen bioelektrischen Impedanz- bzw. Widerstandswerten eine Entscheidung über den Zustand des weiblichen Körpers trifft;

wobei das Display bzw. die Anzeige (42; 54) eine weitere Funktion des Anzeigens des Ergebnisses der so getroffenen Entscheidung aufweist.

6. Vorrichtung, welche eine Entscheidung über den monatlichen physiologischen Zustand eines weiblichen Körpers durchführt, nach Anspruch 5, wobei sie ferner einen Temperaturmesser (55a, 55b) und einen Temperaturspeicher (44) umfasst, der die bisher gemessenen Temperaturwerte bzw. eine historische Aufstellung der Temperatur speichert, wodurch es der Entscheidungsfindungseinheit (45) ermöglicht wird durch Vergleichen der gegenwärtigen bzw. momentanen Temperatur mit den bisher gemessenen Temperaturwerten zusätzlich zum Vergleich der gegenwärtigen bzw. momentanen bioelektrischen Impedanz bzw. dem bioelektrischen Widerstand mit den bisher gemessenen bioelektrischen Impedanz- bzw. Widerstandswerten die erforderliche Entscheidung zu treffen .

7. Vorrichtung, welche eine Entscheidung über den monatlichen physiologischen Zustand eines weiblichen Körpers durchführt, nach Anspruch 1, wobei sie ferner umfasst:

einen Prozessor (45), der eine Modifikation jeder bioelektrischen Impedanz bzw. jedes bioelektrischen Widerstandes bezüglich des Gewichts vornimmt; und  
 einen gewichtsmodifizierten bioelektrischen Impedanz- bzw. Widerstandsspeicher (44), der die bisher gemessenen gewichtsmodifizierten bioelektrischen Impedanz- bzw. Widerstandswerte bzw. eine historische Aufstellung von gewichtsmodifizierter bioelektrischer Impedanz speichert; und  
 eine Entscheidungsfindungseinheit (45), die durch Vergleichen der gegenwärtigen gewichtsmodifizierten bioelektrischen Impedanz bzw. des bioelektrischen Widerstandes mit den bisher gemessenen gewichtsmodifizierten bioelektrischen Impedanz- bzw. Widerstandswerten eine Entscheidung über den Zustand des weiblichen Körpers trifft; und

wobei das Display bzw. die Anzeige (42; 54) eine weitere Funktion des Anzeigens des Ergebnisses der so getroffenen Entscheidung aufweist.

8. Vorrichtung, welche eine Entscheidung über den monatlichen physiologischen Zustand eines weiblichen Körpers durchführt, nach Anspruch 7, wobei sie ferner einen Temperaturmesser (55a, 55b) und einen Temperaturspeicher (44) umfasst, der die bisher gemessenen Temperaturwerte bzw. eine historische Aufstellung der Temperatur speichert, wodurch es der Entscheidungsfindungseinheit (45) ermöglicht wird durch Vergleichen der gegenwärtigen bzw. momentanen Temperatur mit den bisher gemessenen Temperaturwerten zusätzlich zum Vergleich der gegenwärtigen bzw. momentanen gewichtsmodifizierten bioelektrischen Impedanz mit den bisher gemessenen bioelektrischen Impedanz- bzw. Widerstandswerten die Entscheidung über den Zustand des weiblichen Körpers zu treffen .

9. Vorrichtung, welche eine Entscheidung über den monatlichen physiologischen Zustand eines weiblichen Körpers durchführt, nach einem der Ansprüche 5 bis 8, wobei der monatliche physiologische Zustand des weiblichen Körpers das PMS betrifft.

10. Vorrichtung, welche eine Entscheidung über den monatlichen physiologischen Zustand eines weiblichen Körpers durchführt, nach einem der Ansprüche 5 bis 8, wobei sie ferner ein Eingabegerät (41) umfasst, das Zusatzdaten, die die Menstruationsperiode betreffen, eingibt, wodurch es der Entscheidungsfindungseinheit (45) ermöglicht wird diese Zusatzdaten zu berücksichtigen .

11. Vorrichtung, welche eine Entscheidung über den monatlichen physiologischen Zustand eines weiblichen Körpers durchführt, nach Anspruch 10, wobei die Zusatzdaten das Start- bzw. Anfangsdatum der Menstruationsperiode und/oder das Enddatum der Menstruationsperiode beinhalten.

12. Vorrichtung, welche eine Entscheidung über den monatlichen physiologischen Zustand eines weiblichen Körpers durchführt, nach einem der Ansprüche 5 bis 11, wobei das Display bzw. die Anzeige (42; 54) eine weitere Funktion des Anzeigens einer beratenden Mitteilung bzw. eines Ratschlags , die bzw. der die Entscheidung über den monatlichen physiologischen Zustand, aufweist.

13. Vorrichtung, welche eine Entscheidung über den monatlichen physiologischen Zustand eines weiblichen Körpers durchführt, nach Anspruch 12, wobei die beratende Mitteilung bzw. der Ratschlag einen Rat beinhaltet, der die Lebensweise einschließlich gesunde Ernährung bzw. Durchführen einer Diät betrifft.

14. Vorrichtung, welche eine Entscheidung über den monatlichen physiologischen Zustand eines weiblichen Körpers durchführt, nach einem der Ansprüche 5 bis 13, wobei sie ferner eine arithmetische Einheit umfasst, die den Körperfettprozentsatz bezüglich der bioelektrischen Impedanz bzw. dem bioelektrischen Widerstand bestimmt, wobei das Display bzw. die Anzeige (42; 54) eine weitere Funktion des Anzeigens des so bestimmten Körperfettprozentsatz aufweist.

## Revendications

1. Appareil produisant des données destinées à prendre une décision sur l'état physiologique mensuel d'un corps de femme comprenant :

un appareil de mesure d'impédance bioélectrique (20) comprenant une paire d'électrodes appliquant un courant constant (21a, 21b ; 51a, 51b) et une paire d'électrodes de mesure de tension (22a, 22b ; 52a, 52b) appliquées à sa surface supérieure qui peuvent être appliquées à la couche extérieure de la peau du corps de femme, ledit appareil de mesure d'impédance bioélectrique (20) étant adapté pour mesurer l'impédance bioélectrique se produisant entre lesdites paires d'électrodes (21a, 21b, 22a, 22b ; 51a, 51b, 52a, 52b) ;  
 une mémoire d'impédance bioélectrique (44) qui stocke un enregistrement historique de l'impédance bioélectrique ;  
 un affichage (42 ; 54) qui a une fonction consistant à afficher l'enregistrement historique de l'impédance bioélectrique, représentant la manière dont elle a varié ; **caractérisé en ce que** l'appareil comprend en outre une balance (25),  
 ledit affichage (42 ; 54) ayant une autre fonction consistant à afficher le présent poids du corps de femme.

2. Appareil produisant des données destinées à prendre une décision sur l'état physiologique mensuel d'un corps de femme selon la revendication 1, comprenant en outre :

un processeur (45) qui effectue une modification de chaque impédance bioélectrique en terme du poids ; et une mémoire d'impédance bioélectrique modifiée en terme du poids (44) qui stocke un enregistrement historique de l'impédance bioélectrique modifiée en terme du poids ;  
 lesdites données affichées par ledit affichage (42 ; 54) représentant la manière dont ledit enregistrement historique de l'impédance bioélectrique modifiée en terme du poids a varié.

3. Appareil produisant des données destinées à prendre une décision sur l'état physiologique mensuel d'un corps de femme selon la revendication 1 ou 2, comprenant en outre un thermomètre (55a, 55b) et une mémoire de température (44) qui stocke un enregistrement historique de la température, ledit affichage (54) ayant une autre fonction consistant à afficher l'enregistrement historique de la température, représentant la manière dont elle a varié.

4. Appareil produisant des données destinées à prendre une décision sur l'état physiologique mensuel d'un corps de femme selon l'une quelconque des revendications 1 à 3, comprenant en outre une unité arithmétique qui détermine le pourcentage de graisse corporelle en terme de l'impédance bioélectrique, ledit affichage (42 ; 54) ayant une autre fonction consistant à afficher le pourcentage de graisse corporelle ainsi déterminé.

5. Appareil de prise de décision sur l'état physiologique mensuel d'un corps de femme selon la revendication 1, comprenant en outre :

une unité de prise de décision (45) qui prend une décision sur l'état du corps de femme en comparant la présente impédance bioélectrique à l'enregistrement historique de l'impédance bioélectrique ;  
 ledit affichage (42 ; 54) ayant une autre fonction consistant à afficher le résultat de la décision ainsi prise.

6. Appareil de prise de décision sur l'état physiologique mensuel d'un corps de femme selon la revendication 5, comprenant en outre un thermomètre (55a, 55b) et une mémoire de température (44) qui stocke un enregistrement historique de la température, permettant ainsi à ladite unité de prise de décision (45) de prendre la décision requise en comparant la présente température à l'enregistrement historique de la température en plus de la comparaison de la présente impédance bioélectrique à l'enregistrement historique de l'impédance bioélectrique.

7. Appareil de prise de décision sur l'état physiologique mensuel d'un corps de femme selon la revendication 1, comprenant en outre :

un processeur (45) qui effectue une modification de chaque impédance bioélectrique en terme du poids ;  
 une mémoire d'impédance bioélectrique modifiée en terme du poids (44) qui stocke un enregistrement historique de l'impédance bioélectrique modifiée en terme du poids ; et  
 une unité de prise de décision (45) qui prend une décision sur l'état du corps de femme en comparant la présente impédance bioélectrique modifiée en terme du poids à l'enregistrement historique de l'impédance bioélectrique modifiée en terme du poids ; et  
 ledit affichage (42 ; 54) ayant une autre fonction consistant à afficher le résultat de la décision ainsi prise.

8. Appareil de prise de décision sur l'état physiologique mensuel d'un corps de femme selon la revendication 7, comprenant en outre un thermomètre (55a, 55b) et une mémoire de température (44) qui stocke un enregistrement historique de la température, permettant ainsi à ladite unité de prise de décision (45) de prendre une décision sur

## EP 1 084 676 B1

l'état du corps de femme en comparant la présente température à l'enregistrement historique de la température en plus de la comparaison de la présente impédance bioélectrique modifiée en terme du poids à l'enregistrement historique de l'impédance bioélectrique modifiée en terme du poids.

- 5     **9.** Appareil de prise de décision sur l'état physiologique mensuel d'un corps de femme selon l'une quelconque des revendications 5 à 8, dans lequel ledit état physiologique mensuel du corps de femme se rapporte au syndrome prémenstruel.
- 10    **10.** Appareil de prise de décision sur l'état physiologique mensuel d'un corps de femme selon l'une quelconque des revendications 5 à 8, comprenant en outre un dispositif d'entrée (41) qui entre des données supplémentaires concernant la menstruation, permettant ainsi à ladite unité de prise de décision (45) de prendre en compte de telles données supplémentaires.
- 15    **11.** Appareil de prise de décision sur l'état physiologique mensuel d'un corps de femme selon la revendication 10, dans lequel lesdites données supplémentaires comprennent la date de début de la menstruation et/ou la date de fin de la menstruation.
- 20    **12.** Appareil de prise de décision sur l'état physiologique mensuel d'un corps de femme selon l'une quelconque des revendications 5 à 11, dans lequel ledit affichage (42 ; 54) a une autre fonction consistant à afficher un message de conseil relatif à la décision sur l'état physiologique mensuel.
- 25    **13.** Appareil de prise de décision sur l'état physiologique mensuel d'un corps de femme selon la revendication 12, dans lequel ledit message de conseil comprend des conseils relatifs à l'hygiène de vie, y compris le régime alimentaire.
- 30    **14.** Appareil de prise de décision sur l'état physiologique mensuel d'un corps de femme selon l'une quelconque des revendications 5 à 13, comprenant en outre une unité arithmétique qui détermine un pourcentage de graisse corporelle en terme de l'impédance bioélectrique, ledit affichage (42 ; 54) ayant une autre fonction consistant à afficher le pourcentage de graisse corporelle ainsi déterminé.

30

35

40

45

50

55

FIG.1

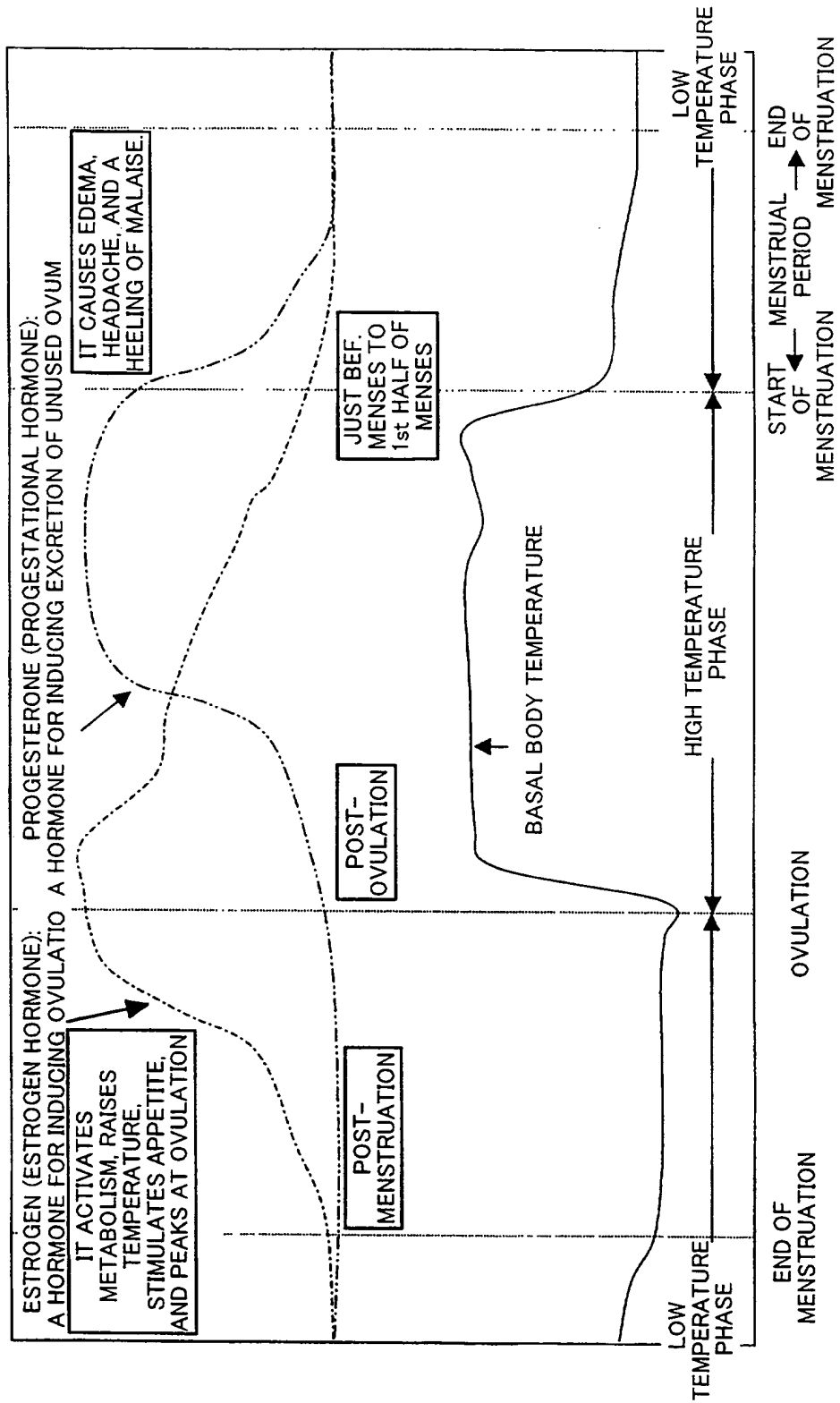

FIG.2

SUBJECT A: CHANGE OF BASAL BODY TEMPERATURE AND BI APPEARING BETWEEN BOTH FEET (NO MODIFICATION)

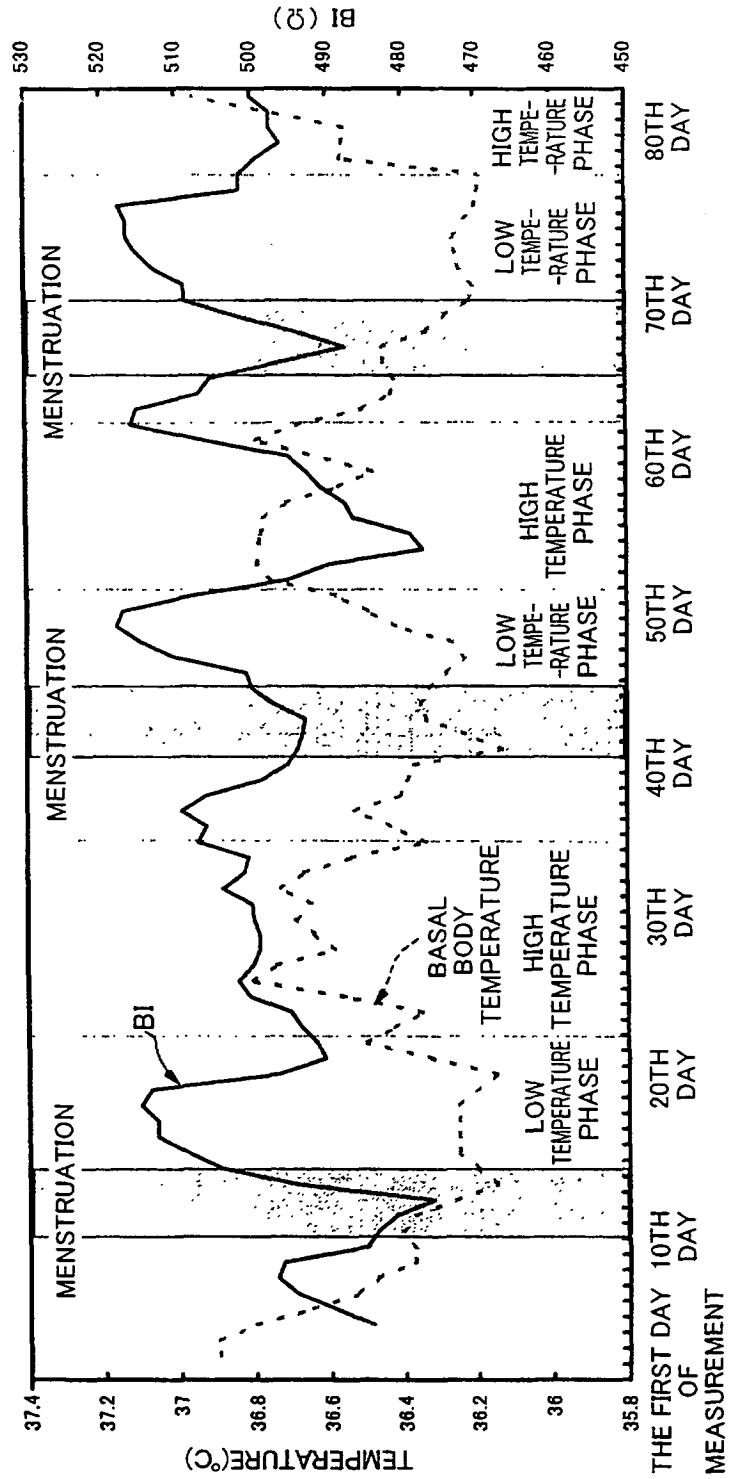

FIG.3

SUBJECT A: CHANGE OF WEIGHT

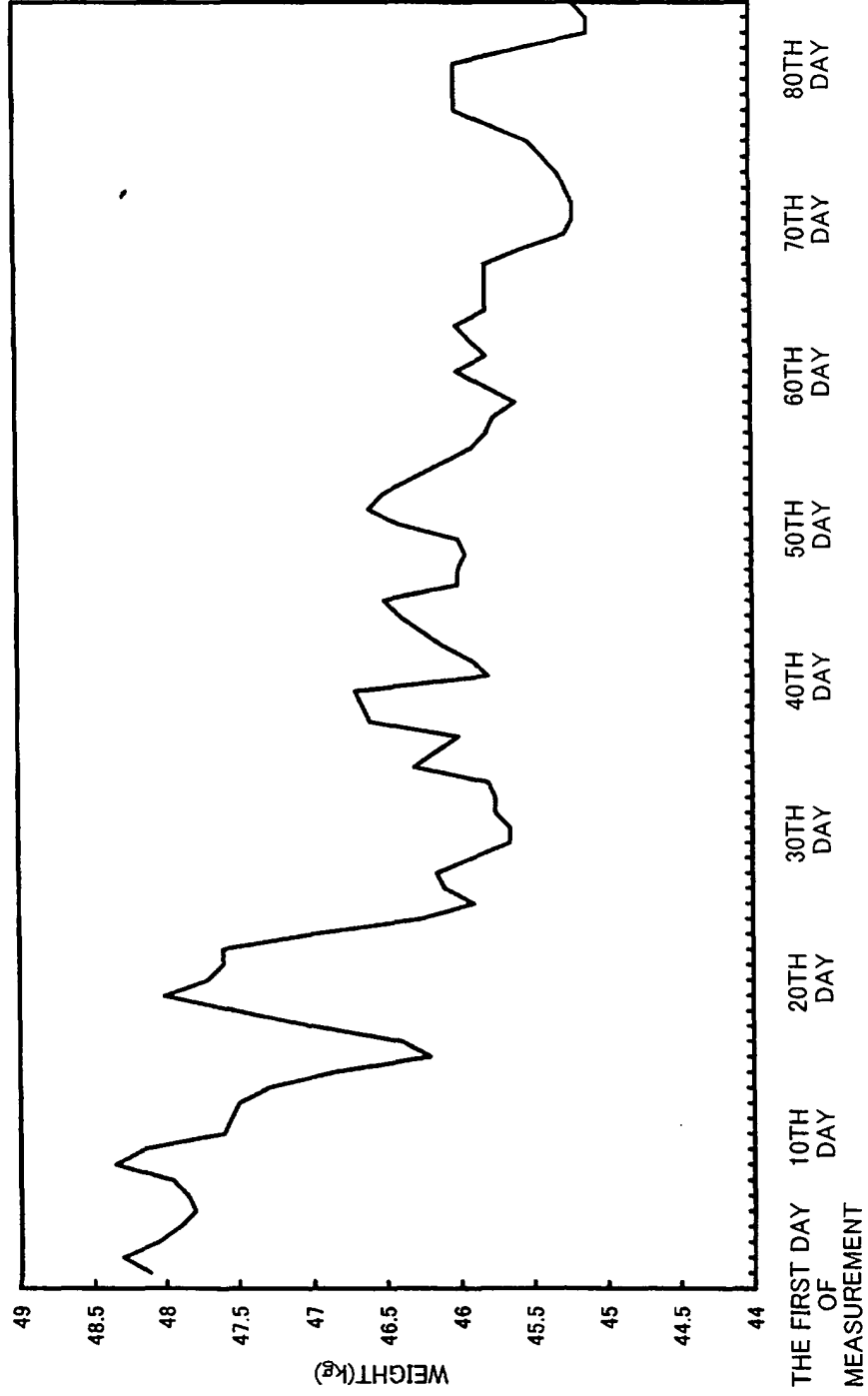
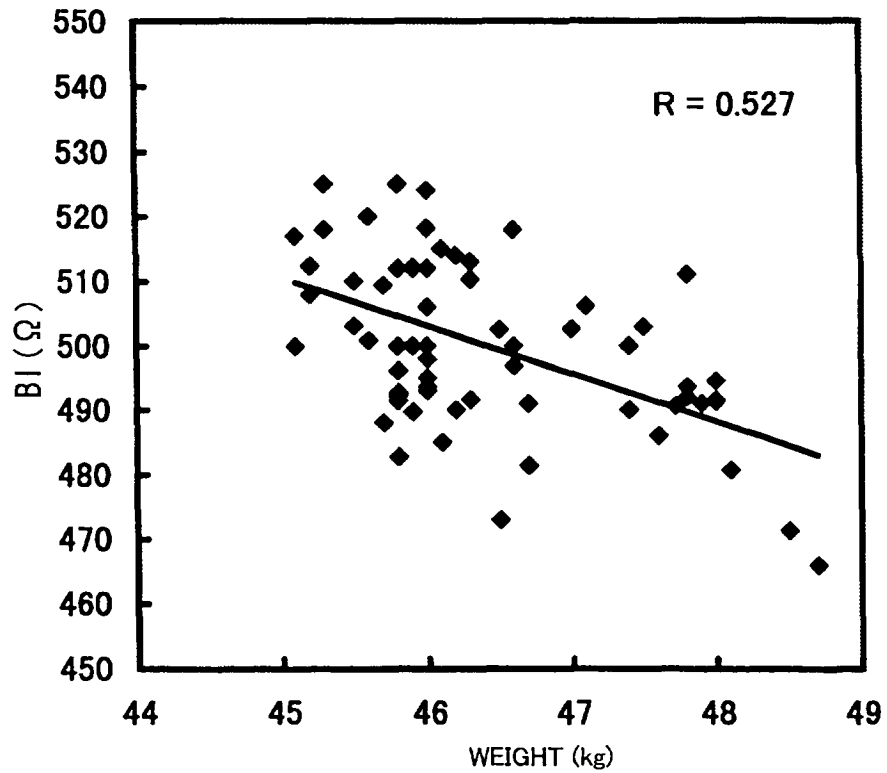

FIG.4

SUBJECT A: CORRELATION BETWEEN WEIGHT AND BI APPEARING BETWEEN BOTH FEET (NO MODIFICATION)



R: CORRELATION COEFFICIENT  
IT REPRESENTS THE DEGREE TO WHICH TWO VARIABLES CORRELATE.  
IT CAN REPRESENT ANY NUMBER FROM 0.0 TO 1.0. THE HIGHER THE VALUE IS,  
THE STRONGER THE CORRELATION IS. (R=0.0 MEANS THERE IS NO  
CORRELATION, AND R=1.0 INDICATES A STRAIGHT LINE OF X=Y.)

FIG.5

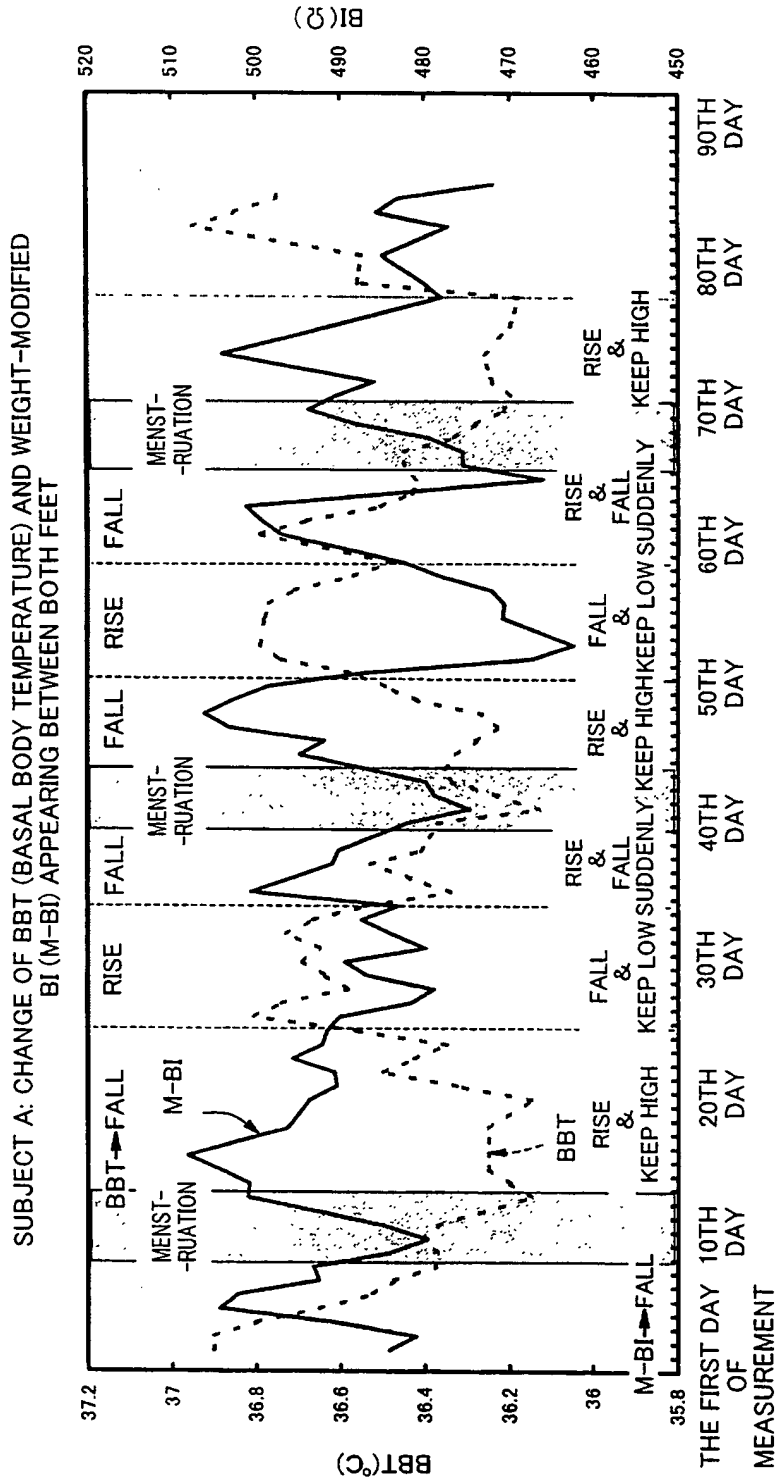
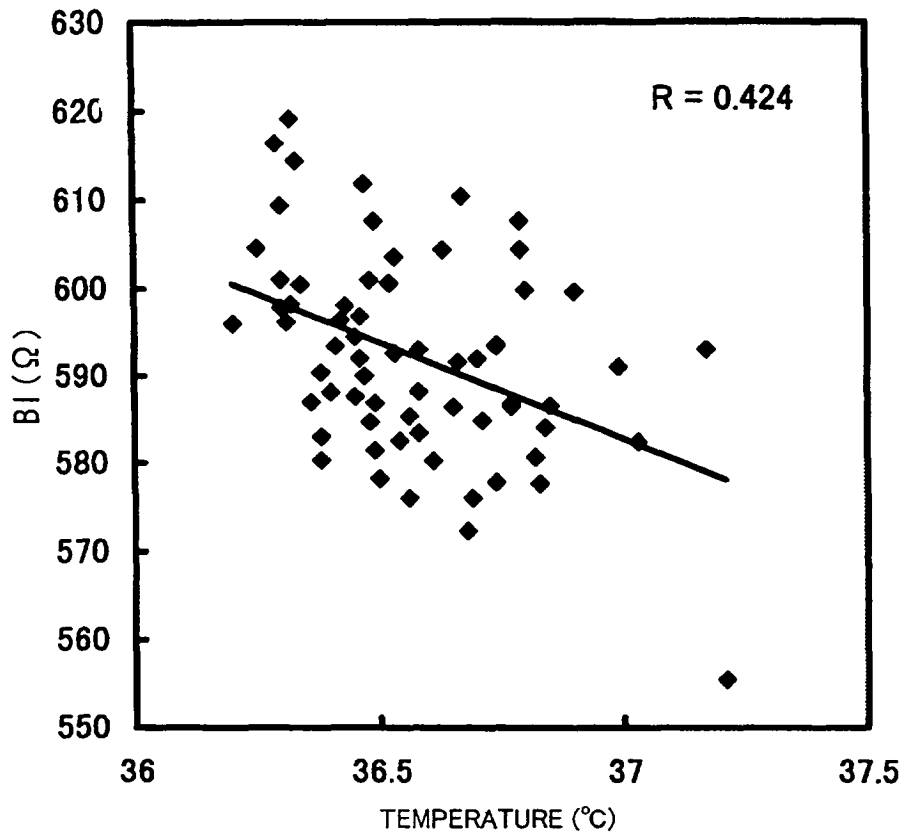

FIG.6

SUBJECT A: CORRELATION BETWEEN BASAL BODY TEMPERATURE AND WEIGHT-MODIFIED BI APPEARING BETWEEN BOTH FEET



R: CORRELATION COEFFICIENT

FIG.7

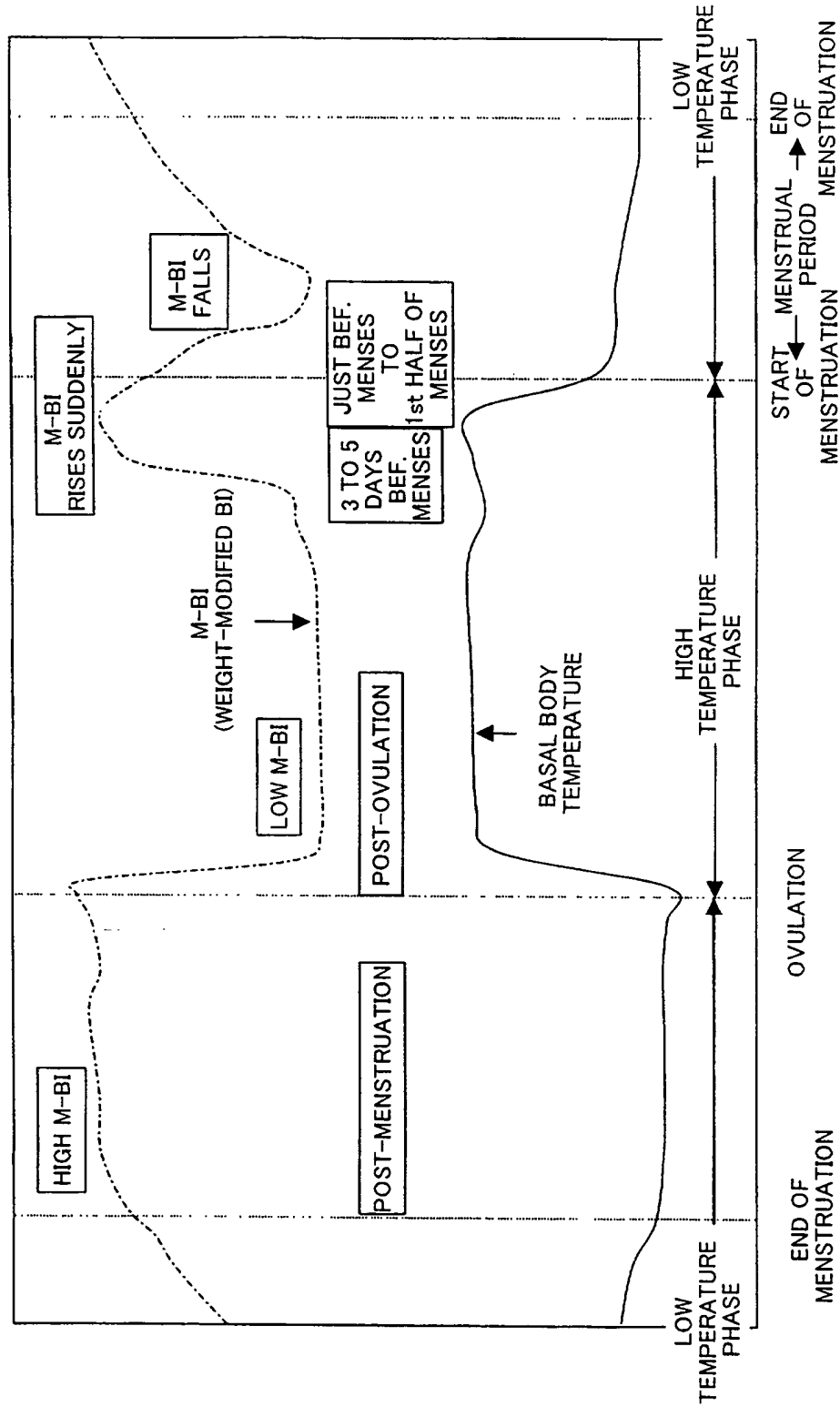

FIG.8

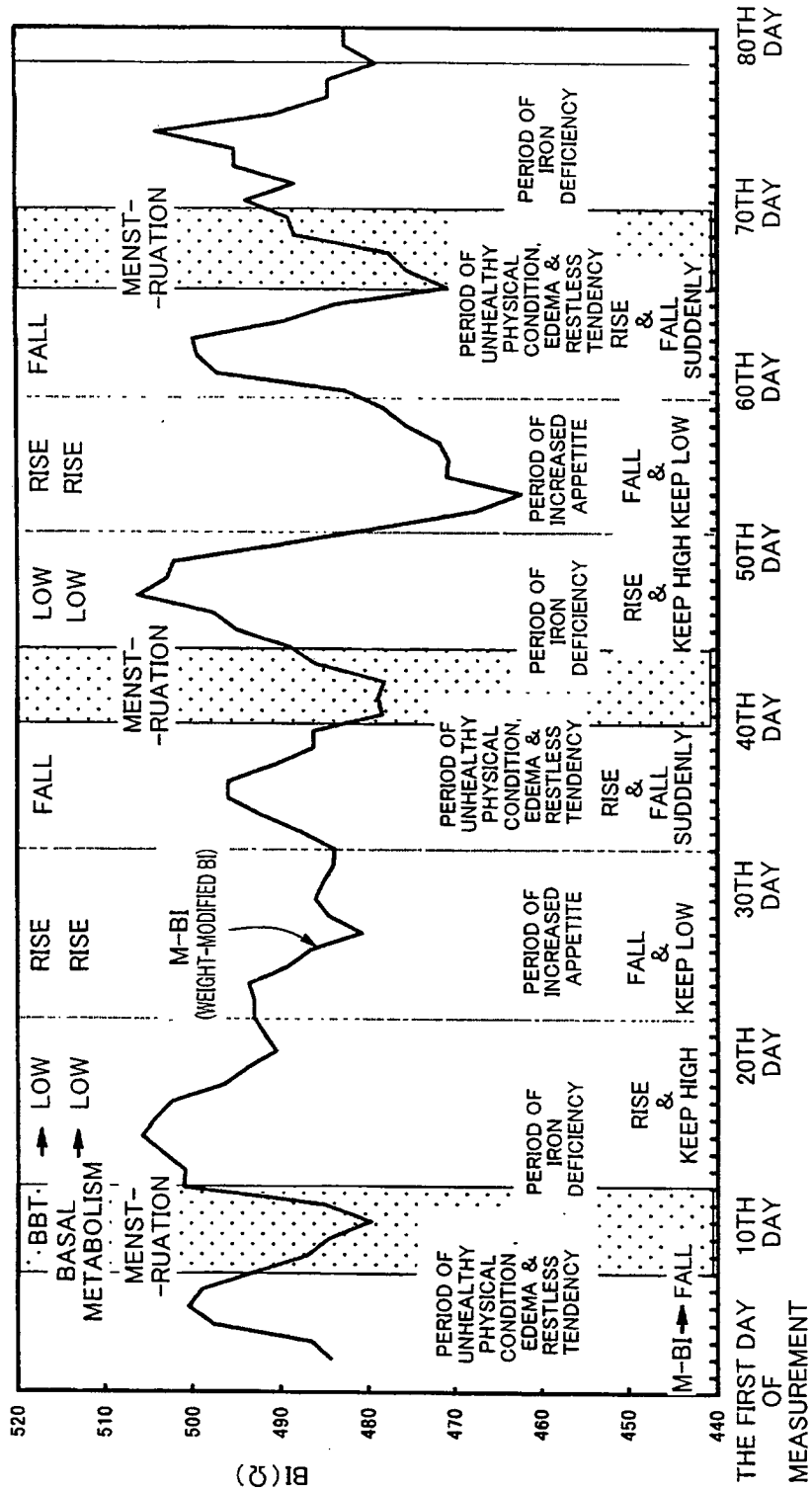

FIG.9

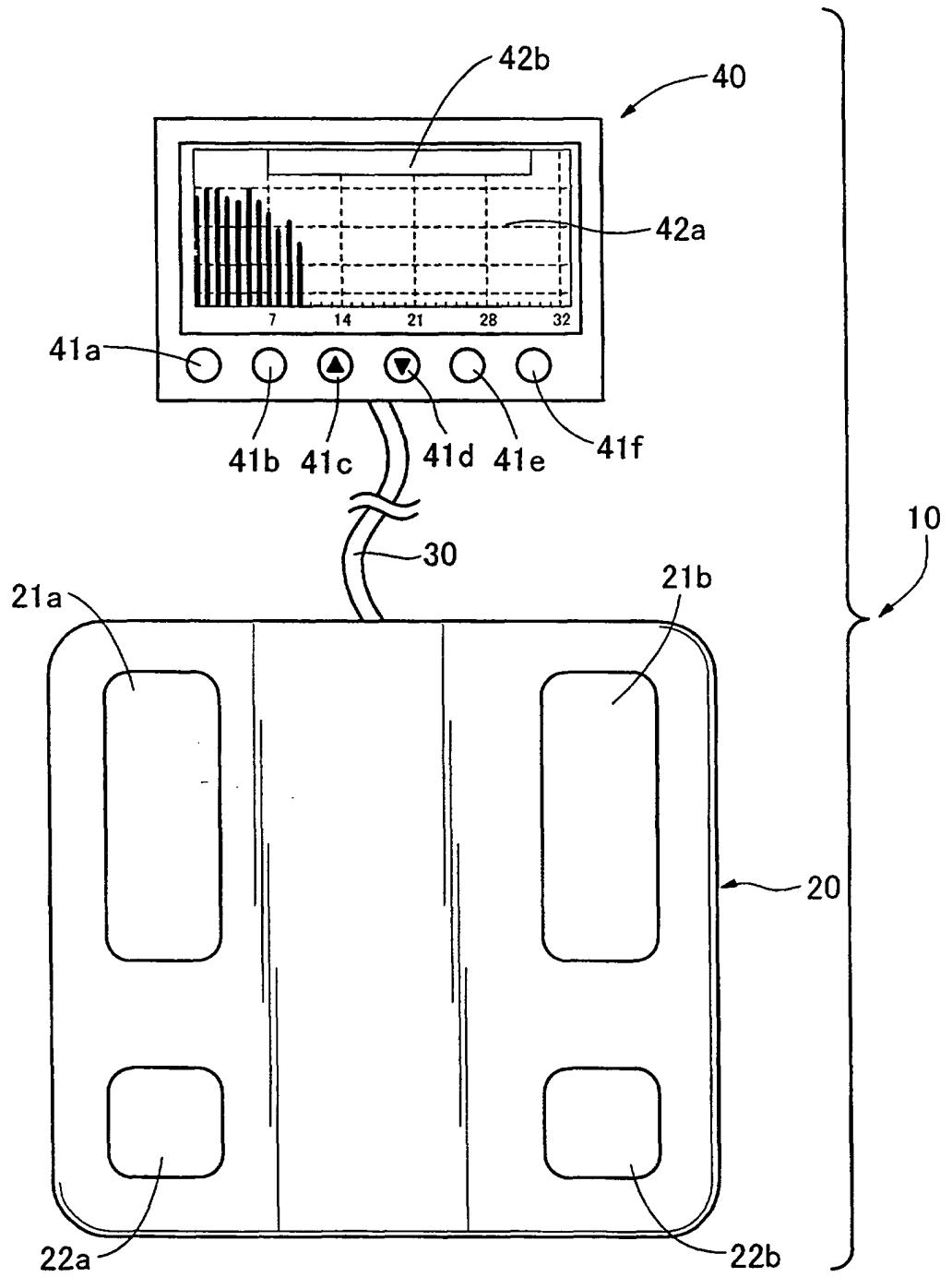

FIG.10

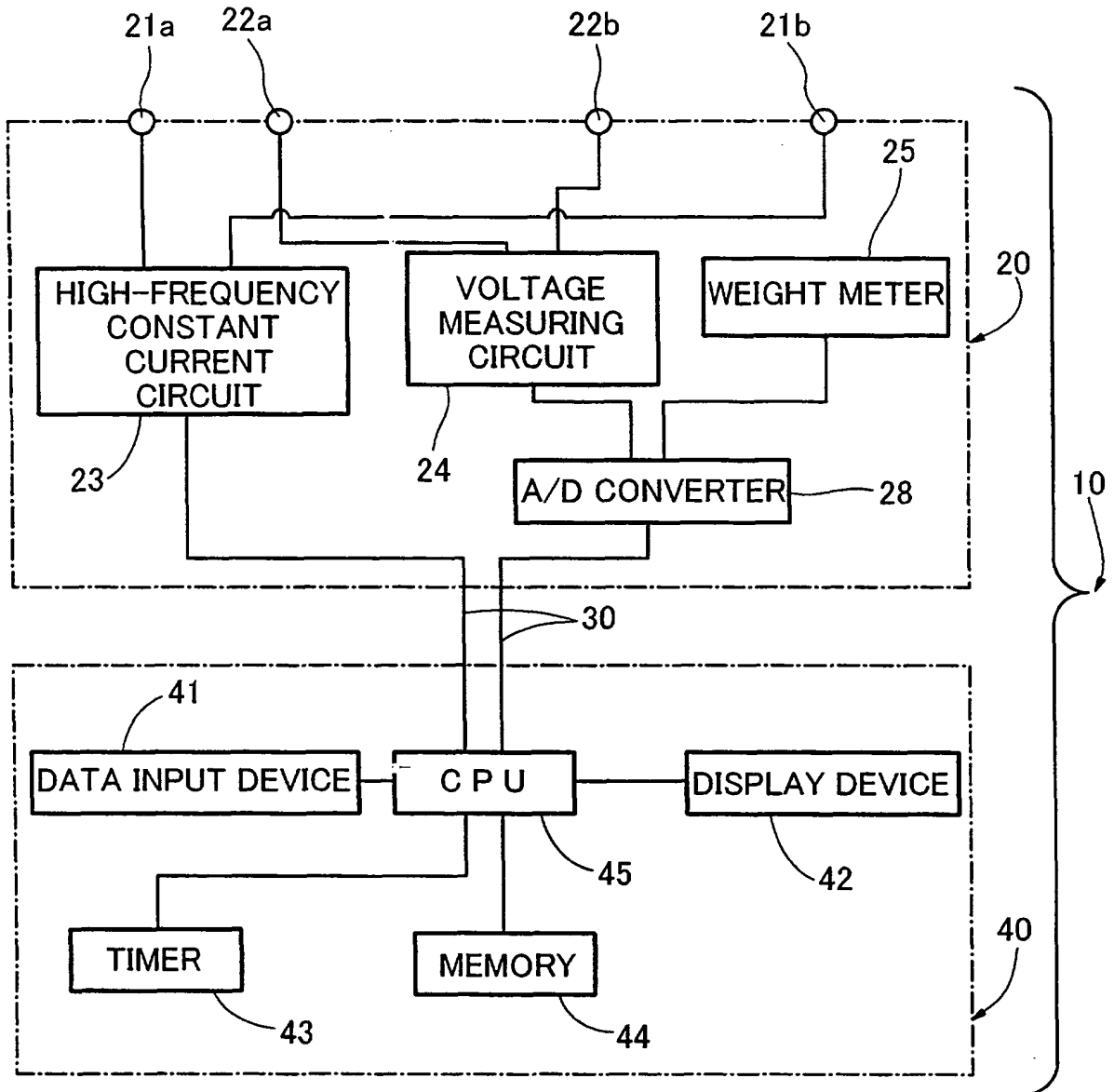

FIG.11

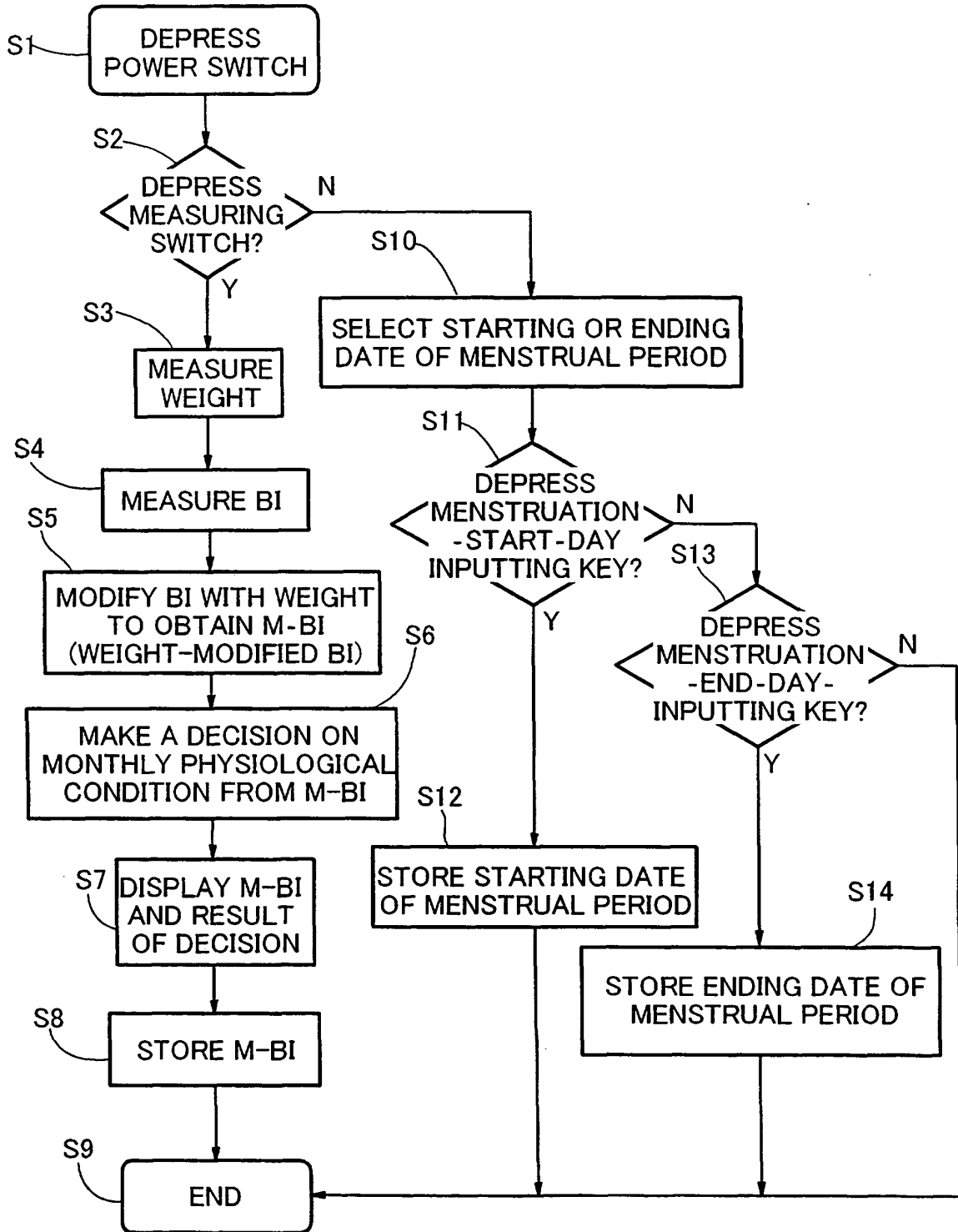
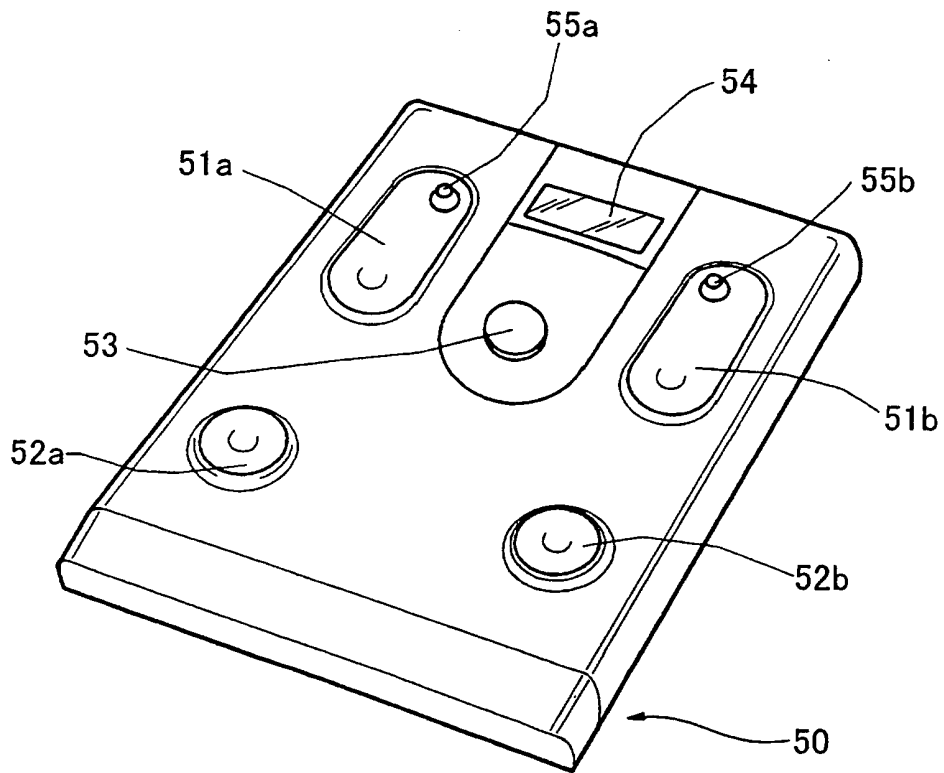

FIG.12



专利名称(译)	决定女性身体每月生理状况的装置		
公开(公告)号	<a href="#">EP1084676B1</a>	公开(公告)日	2007-04-25
申请号	EP2000119415	申请日	2000-09-12
[标]申请(专利权)人(译)	株式会社百利达		
申请(专利权)人(译)	TANITA CORPORATION		
当前申请(专利权)人(译)	TANITA CORPORATION		
[标]发明人	KODAMA MIYUKI SATO HITOSHI		
发明人	KODAMA, MIYUKI SATO, HITOSHI		
IPC分类号	A61B5/05 A61B5/00 A61B10/00 A61B5/053		
CPC分类号	A61B10/0012 A61B5/0537 A61B5/4869 A61B5/4872 A61B5/6887 A61B2010/0016 A61B2010/0019 A61B2560/0468		
优先权	1999258538 1999-09-13 JP		
其他公开文献	EP1084676A1		
外部链接	<a href="#">Espacenet</a>		

摘要(译)

本发明涉及一种对诸如排卵和PMS的女性身体的每月生理状况作出决定的方法，作出这种决定的装置以及产生用于这种决定的一些数据的装置。为了能够做出这样的决定，定期地确定女性身体的生物电阻抗，以提供代表其如何变化的生物电阻抗的历史记录；并且通过将当前生物电阻抗与生物电阻抗的历史记录进行比较来进行所需的决定，或者显示生物电阻抗的历史记录，表示其如何变化。

