



(51) International Patent Classification:

A61B 5/00 (2006.01) A61B 5/026 (2006.01)
A61B 5/0205 (2006.01) A61B 5/042 (2006.01)
A61B 5/0215 (2006.01) A61F 2/24 (2006.01)

(21) International Application Number:

PCT/IB2015/055240

(22) International Filing Date:

10 July 2015 (10.07.2015)

(25) Filing Language:

English

(26) Publication Language:

English

(30) Priority Data:

62/023,891 13 July 2014 (13.07.2014) US
62/039,952 21 August 2014 (21.08.2014) US

(71) Applicant: **THREE RIVERS CARDIOVASCULAR SYSTEMS INC.** [CA/CA]; 21 Cremorne Avenue, Toronto, Ontario M8Z 3L6 (CA).

(72) Inventor: **CARON, Eric**; 21 Cremorne Avenue, Toronto, Ontario M8Z 3L6 (CA).

(72) Inventor: **BILODEAU, Luc** (deceased).

(74) Agent: **DE WILTON, Angela**; de Wilton Intellectual Property Inc., 499 Tillbury Avenue, Ottawa, Ontario K2A 4G8 (CA).

(81) Designated States (unless otherwise indicated, for every

kind of national protection available): AE, AG, AL, AM, AO, AT, AU, AZ, BA, BB, BG, BH, BN, BR, BW, BY, BZ, CA, CH, CL, CN, CO, CR, CU, CZ, DE, DK, DM, DO, DZ, EC, EE, EG, ES, FI, GB, GD, GE, GH, GM, GT, HN, HR, HU, ID, IL, IN, IR, IS, JP, KE, KG, KN, KP, KR, KZ, LA, LC, LK, LR, LS, LU, LY, MA, MD, ME, MG, MK, MN, MW, MX, MY, MZ, NA, NG, NI, NO, NZ, OM, PA, PE, PG, PH, PL, PT, QA, RO, RS, RU, RW, SA, SC, SD, SE, SG, SK, SL, SM, ST, SV, SY, TH, TJ, TM, TN, TR, TT, TZ, UA, UG, US, UZ, VC, VN, ZA, ZM, ZW.

(84) Designated States (unless otherwise indicated, for every

kind of regional protection available): ARIPO (BW, GH, GM, KE, LR, LS, MW, MZ, NA, RW, SD, SL, ST, SZ, TZ, UG, ZM, ZW), Eurasian (AM, AZ, BY, KG, KZ, RU, TJ, TM), European (AL, AT, BE, BG, CH, CY, CZ, DE, DK, EE, ES, FI, FR, GB, GR, HR, HU, IE, IS, IT, LT, LU, LV, MC, MK, MT, NL, NO, PL, PT, RO, RS, SE, SI, SK, SM, TR), OAPI (BF, BJ, CF, CG, CI, CM, GA, GN, GQ, GW, KM, ML, MR, NE, SN, TD, TG).

Declarations under Rule 4.17:

- as to the identity of the inventor (Rule 4.17(i))
- as to applicant's entitlement to apply for and be granted a patent (Rule 4.17(ii))
- as to the applicant's entitlement to claim the priority of the earlier application (Rule 4.17(iii))

[Continued on next page]

(54) Title: SYSTEM AND APPARATUS COMPRISING A MULTISENSOR GUIDEWIRE FOR USE IN INTERVENTIONAL CARDIOLOGY

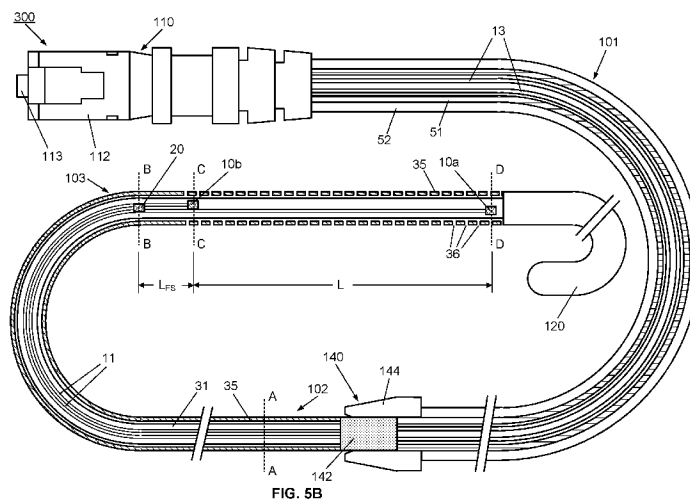

(57) Abstract: A system (1) and apparatus comprising a multisensor guidewire (100/200/300) for use in interventional cardiology, e.g., Transcatheter Valve Therapies (TVT), comprises a plurality of optical sensors (10/20) for direct measurement of cardiovascular parameters, e.g. transvalvular blood pressure gradients and flow. A conventional outer coil wire (35) contains a shaped core wire (31) having a cross-section defining a channel surface (132), e.g. grooves (32), extending along its length, to position optical fibers (11) and optical sensors (10/20) in a channel (33). Advantageously, the core wire has a diameter that provides sufficient stiffness to the guidewire for use as a support guidewire for TVT, e.g. Transcatheter Aortic Valve Implantation (TAVI), while accommodating multiple sensors and fibers within a guidewire of outside diameter ≤ 0.89 mm. An optical connector (112) couples the guidewire to a control system (150). Optionally, the guidewire includes a contact force sensor (60), a pre-formed tip (400-1/400-2) and a separable micro-connector (140).

WO 2016/009317 A1

— *of inventorship (Rule 4.17(iv))*

Published:

— *with international search report (Art. 21(3))*

— *before the expiration of the time limit for amending the claims and to be republished in the event of receipt of amendments (Rule 48.2(h))*

**SYSTEM AND APPARATUS COMPRISING A MULTISENSOR GUIDEWIRE
FOR USE IN INTERVENTIONAL CARDIOLOGY**

CROSS-REFERENCE TO RELATED APPLICATIONS

[001] This application claims priority from United States provisional patent application
5 no. 62/023,891, entitled “System And Apparatus Comprising a Multisensor Support
Guidewire for Use in Trans-Catheter Heart Valve Therapies”, filed July 13, 2014 and
from United States provisional patent application no. 62/039,952, entitled “System And
Apparatus Comprising a Multisensor Support Guidewire for Use in Trans-Catheter Heart
Valve Therapies”, filed August 21, 2014; both applications are incorporated herein by
10 reference in their entirety.

[002] This application is related to PCT International Application no.
PCT/IB2012/055893, entitled “Apparatus, system and methods for measuring a blood
pressure gradient”, filed October 26, 2012, which claims priority from United States
provisional patent application no. 61/552,778 entitled “Apparatus, system and methods
15 for measuring a blood pressure gradient”, filed October 28, 2011 and from United States
provisional patent application no. 61/552,787 entitled “Fluid temperature and flow sensor
apparatus and system for cardiovascular and other medical applications”, filed October
28, 2011, all of which are incorporated herein by reference, in their entirety.

TECHNICAL FIELD

20 [003] The present invention relates to a system and apparatus comprising a guidewire
for use in interventional cardiology, e.g. for Transcatheter heart Valve Therapies (TVT),
such as, for Trans-catheter Aortic Valve Implantation (TAVI) and for related diagnostic
measurements.

BACKGROUND

25 [004] If a heart valve is found to be malfunctioning because it is defective or diseased,
minimally invasive methods are known for repair and replacement of the heart valve.
Transcatheter Valve Therapies (TVT) include procedures referred to as Transcatheter
Aortic Valve Implantation (TAVI) and Transcatheter Mitral Valve Implantation (TMVI).

[005] TVT provides methods for replacing diseased valves which avoid the need for open heart surgery. Procedures such as TAVI have been developed over the last decade and have become more common procedures in recent years. While there have been many recent advances in systems and apparatus for TVT and for related diagnostic procedures, 5 interventional cardiologists who perform these procedures have identified the need for improved apparatus for use in TVT, such as, heart valve replacement. They are also seeking improved diagnostic equipment that provides direct measurements of important hemodynamic cardiovascular parameters before, during and after TVT.

[006] The above referenced related PCT application no. PCT/IB2012/055893 10 (Publication no. WO/2013/061281), having common inventorship and ownership with the present application, discloses a multisensor micro-catheter or guidewire which comprises a distal end portion containing multiple optical sensors arranged for measuring blood pressure at several sensor locations simultaneously in real-time, and optionally also blood flow. In particular, the multisensor micro-catheter or guidewire is designed for use 15 in minimally invasive surgical procedures for measurement of intra-vascular pressure gradients, and in particular, for direct measurement of a transvalvular pressure gradient within the heart.

[007] To obtain accurate measurements of hemodynamic parameters such as blood pressure, blood flow, a blood pressure gradient, or other parameters within the heart, it is 20 desirable that the sensor guidewire does not interfere with normal operation of the heart and the heart valves. Thus, beneficially, a fine diameter guidewire, e.g. ≤ 0.89 mm diameter, with a flexible tip, facilitates insertion through a heart valve without trauma, and reduces interference with valve operation. That is, when the sensor guidewire is inserted through the valve, it preferably causes minimal interference with the movement 25 of the valve and/or does not significantly perturb the transvalvular pressure gradient or other parameters. For example, in use, a multisensor guidewire may be introduced via the aorta, through the aortic valve, and positioned so that the optical pressure sensors are located both upstream and downstream of the aortic valve, for direct measurement of the transvalvular blood pressure gradient, and optionally also blood flow, with minimal 30 disruption of the normal operation of the aortic valve. Accordingly, a fine gauge

guidewire minimizes disruption of the heart valve activity during measurement, to obtain accurate measurements of the transvalvular pressure gradient or other parameters.

[008] A reliable measurement of a transvalvular pressure gradient through several cardiac cycles is an important parameter to assess whether the heart valve is functioning well or malfunctioning. An optical multisensor pressure sensing guidewire of this structure provides a valuable tool that an interventional cardiologist can use to facilitate direct measurements of cardiovascular parameters, including a transvalvular pressure gradient. Such measurements provide information relating to parameters, such as, an aortic regurgitation index, stenotic valve orifice area and cardiac output.

[009] As described in the above referenced related patent applications, typically, a support guidewire used for TVT comprises an outer layer in the form of a flexible metal coil, and a central metal core wire or mandrel. The outer metal coil and inner core wire act together to provide a suitable combination of flexibility and stiffness, which, together with a suitably shaped tip, allow the guidewire to be directed or guided through the blood vessels into the heart. In the multisensor guidewire disclosed in the above referenced PCT International Application no. PCT/IB2012/055893, the optical sensors, e.g. 3 or 4 optical pressure sensors are located in a distal end portion of the sensor guidewire, and coupled by respective individual optical fibers to an optical input /output at the proximal end of the guidewire. It will be appreciated that to fit a plurality of optical sensors and optical fibers within a guidewire comprising a small gauge ($\leq 0.89\text{mm}$) outer coil, the diameter of core wire is made as small as possible, i.e. to allow sufficient space around the core wire to accommodate the optical fibers and sensors. However, use of a smaller diameter core wire significantly reduces the stiffness of the multisensor guidewire. That is, the optical fibers and sensors take up space within the micro-catheter or guidewire coil but do not contribute significantly to the stiffness.

[010] In testing of prototype multisensor guidewires, it has been found that the strong blood flow and turbulence within the heart can be sufficient to displace a small-gauge flexible guidewire, and tends to push the guidewire back into the aorta. Thus, during measurement of a transvalvular pressure gradient, movement of the guidewire may create difficulty in positioning the sensors and the cardiologist may need to readjust the

positioning of the guidewire to maintain the pressure sensors each side of the heart valve. On the other hand, in a multisensor guidewire of this structure, to accommodate a plurality of optical sensors and respective optical fibers around a larger diameter stiffer core wire would require a larger outside diameter outer coil, i.e. larger than 0.89mm.

5 While a larger gauge, stiffer guidewire would be less easily displaced during measurements, for measurement of transvalvular pressure gradients, it would tend to interfere more with normal heart valve operation, and may increase the risk of tissue damage. Accordingly, a need for further improvements has been identified.

[011] If diagnostic measurements of hemodynamic/cardiac parameters indicate the need
10 for valve replacement, minimally invasive TAVI procedures, such as TAVI, can be performed to insert a replacement or prosthetic valve, e.g. comprising leaflets made of biologic tissue supported within an expandable metal frame.

[012] Examples of current prosthetic valves and valve delivery systems are illustrated and described and illustrated in an article entitled “Current Status of Transcatheter Aortic
15 Valve Replacement”, by John G. Webb, MD, David A. Wood, M, Vancouver, British Columbia, Canada; *Journal of the American College of Cardiology*, Vol. 60, No. 6, 2012.

[013] Very briefly, the procedure requires that a support guidewire, which is relatively stiff guidewire (TAVI guidewire) with a flexible tip, is introduced into the heart and through the aortic valve. For example, the interventional cardiologist introduces the
20 support guidewire through a catheter inserted into the femoral artery, i.e. in the groin, and moves it up through the aorta into the heart. The tip of the TAVI guidewire is introduced into the aorta, through the malfunctioning aortic valve, and into the left ventricle of the heart. Once the support guidewire is anchored within the ventricle, a delivery device holding the replacement valve is passed over the support guidewire. The cardiologist
25 guides the delivery device carrying the replacement valve over the support guidewire and manoeuvres the valve into position within the aortic valve. The replacement valve is expanded, so that the patient’s malfunctioning aortic valve is pushed out of the way. The valve frame may be self-expandable or balloon-expandable, depending on the valve type and the delivery system. Once expanded, the metal frame engages the wall of the aorta
30 and holds the replacement valve in position. When the delivery system is withdrawn, the

leaflets on the replacement valve are able to unfold and then function in a manner similar to the leaflets of the natural aortic valve.

[014] Commercial availability of an optical multisensor guidewire as described in the above referenced co-pending patent application would provide the interventional cardiologist with a useful tool for directly measuring a pressure gradient before and after such a procedure for valve repair or replacement, e.g. for TAVI. For example, it is envisaged that the interventional cardiologist would introduce the fine gauge multisensor guidewire to measure a transvalvular pressure gradient, and optionally blood flow, to assess pre-implantation functioning of the heart and the damaged or malfunctioning aortic valve. After withdrawing the multisensor guidewire, the cardiologist would perform a transcatheter heart aortic valve implantation procedure using a specialized, more robust and stiffer, support guidewire (TAVI guidewire) to deliver the valve implant into the heart and perform the implantation. Subsequently after completing the TAVI procedure the TAVI guidewire would be withdrawn. The multisensor guidewire would then be reintroduced to measure a transvalvular pressure gradient and flow, to assess post-implant functioning of the replacement valve.

[015] For TAVI, a relatively stiff support guidewire, typically .035 inch or 0.89 mm in diameter, is required. For example, guidewire manufacturers may use a descriptive term, such as, "stiff" or "super stiff" to provide an indication of the guidewire stiffness. Based on experience, an interventional cardiologist will select a guidewire with an appropriate stiffness and/or other mechanical characteristics to suit a particular TVT procedure. Such a description of stiffness or flexibility can be related in mechanics to a measurement of a flexural modulus, which is a ratio of stress to strain in flexural deformation, or, what may be described as the tendency for a material to bend.

[016] During a TAVI procedure, the support guidewire must be firmly anchored within the left ventricle so that the replacement valve can be accurately positioned and held firmly in place while it is expanded. When such a guidewire is introduced into the left ventricle of the heart through the aortic valve, if too much force is applied to the guidewire or it is pushed too far, there is some risk that the guidewire could cause damage or trauma to the heart tissues, e.g. damage to the aortic wall or ventricular

perforation and pericardial effusion resulting in pericardial tamponade. Moreover, there is increased risk of trauma or damage to the heart wall in a diseased, weakened or calcified heart. To reduce risk of trauma or ventricular perforation, typically the tip of the support guidewire is relative soft and flexible. It may be pre-formed as a J-tip or it
5 may be resiliently deformable so that it can be manually shaped as required by the cardiologist. Recently, specialized TAVI guidewires have become commercially available with pre-formed curved tips of other forms. For example, the Boston Scientific Safari™ pre-shaped TAVI guidewire has a double curve tip, and the Medtronic Confida™ Brecker Curve™ guidewire has a spiral tip. Reference is also made, by way
10 of example, to structures described in US patent publication no. US2012/0016342 and PCT Publication no. WO2010/092347, each to Brecker, entitled “Percutaneous Guidewire”; PCT Publication no. WO2014/081942, to Mathews et al., entitled “Preformed Guidewire”; and PCT Publication no.2004/018031 to Cook, entitled “Guidewire”. See also, an article by D.A. Roy *et al.*, entitled “First-in-man assessment
15 of a dedicated guidewire for transcatheter aortic valve implantation”, EuroIntervention 2013; 8, pp.1019-1025.

[017] While significant advances have recently been made, interventional cardiologists have identified a need for further improvements or alternatives to available guidewires and diagnostic tools for use in minimally invasive cardiac procedures, such as TAVI, or
20 other TVT. In particular, it is desirable to have improved apparatus to simplify or facilitate TVT procedures, including apparatus that will assist in reducing the risk of tissue trauma, e.g. damage to the aorta, the valve or the ventricular wall when much force is exerted on the support guidewire. Additionally, improved systems and apparatus that would provide for direct (*in situ*) diagnostic measurements before and after TVT
25 procedures would potentially assist in understanding factors that contribute to successful outcomes and/or issues that may contribute to mortality or need for re-intervention.

[018] Thus, an object of the present invention is to provide for improvements or alternatives to known cardiovascular support guidewires for TVT and/or to multisensor guidewires for that enable direct measurements of cardiovascular parameters, such as a
30 transvalvular pressure gradient.

SUMMARY OF INVENTION

[019] The present invention seeks to mitigate one or more disadvantages of known systems and apparatus for measuring cardiovascular parameters, and/or for performing interventional cardiac procedures, including transcatheter valve therapies (TVT), such as transcatheter aortic valve implantation (TAVI).

[020] A first aspect of the invention provides multisensor guidewire for diagnostic measurements in interventional cardiology comprising:

an outer flexible coil wire (coil) having a length extending between a proximal end and a distal end, an outside diameter of ≤ 1 mm, and a core wire extending within the coil from the proximal end to the distal end, the distal end comprising a flexible distal tip;

a sensor arrangement comprising a plurality of optical sensors and a plurality of optical fibers; a sensor end of each optical fiber being attached (i.e. integral with or bonded to) and optically coupled to an individual one of the plurality of optical sensors; the plurality of optical fibers extending within the coil from the proximal end to sensor locations within a distal end portion of the coil, proximal to the distal tip;

the core wire having a cross-sectional profile defining a channel means along a length of the core wire, the channel means comprising part of a surface of the core wire providing at least one channel, between a channel surface of the core wire and the coil, accommodating therein the plurality of optical sensors and their respective optical fibers;

a proximal end of each of the plurality of optical fibers being coupled to an optical input/output connector at the proximal end of the guidewire for connection to an optical control system; and

the plurality of optical sensors of the sensor arrangement including two or more optical pressure sensors at respective sensor locations spaced apart along a length of the distal end portion of the core wire.

[021] Thus a specially shaped core wire is provided which is grooved or otherwise surface channelled to position the optical fibers and their respective sensors. The

plurality of optical fibers and optical sensors sit within the channel or recess formed by the channel surface of the core wire, preferably within a diameter D_{core} of the core wire. For example, the channel surface comprises one groove or a plurality of grooves defined in the surface of the core wire along its length. Each groove may accommodate a single
5 fiber and sensor, or, alternatively each groove may accommodate a plurality of fibers and sensors, within a diameter D_{core} of the core wire.

[022] The core wire may have a simpler cross-sectional profile in which the channel surface is defined by removal of a minor segment of a generally circular cross-sectional profile of the core wire, e.g. formed by grinding or wire rolling or wire drawing, to
10 provide a cross-section having a generally D-shape or lune-shape. The optical fibers and optical sensors thus sit against, and may be bonded adhesively to the channel surface, and within the diameter D_{core} of the core wire along its length.

[023] If required, e.g. if the sensors are of larger diameter than the optical fibers, at sensor positions in the distal end portion, recesses or cavities may be formed in the core
15 wire at sensor locations to accommodate the optical sensors. The cavities may also accommodate radiopaque markers for locating the sensors in use, e.g., by conventional radio-imaging techniques.

[024] In an embodiment, the channel surface comprises a single contoured groove, e.g. with a shape and dimensions large enough to be formed by conventional wire-drawing or
20 wire-rolling processes, which positions and accommodates several fibers within the diameter D_{core} of the core wire.

[025] The optical fibers are preferably adhesively bonded or otherwise fixed to the channel surface of the core wire at one or more points along the length of the core wire. Preferably, the plurality of optical sensors including two or more optical pressure sensors
25 at sensor locations spaced apart along a length of the distal end portion of the core wire, for placement upstream and downstream of a heart valve for measuring a transvalvular pressure gradient. Optionally, the plurality of optical sensors further comprises an optical flow sensor, for measurement of blood flow.

[026] Preferably, the material and diameter D_{core} of the core wire, in at least the distal end portion, provides a flexural modulus of a predetermined stiffness to the guidewire. Typically, this stiffness may be described by guidewire manufactures using descriptors such as “stiff” or “super stiff”. The stiffness may be quantified by a flexural modulus, e.g. as described in an article by G. J. Harrison et al., entitled “Guidewire Stiffness: What’s in a Name?” J. Endovasc. Ther. 2011, pp. 797-801. As an example, for, a stainless steel coil and core wire providing a guidewire having an outside diameter of 0.89mm (0.035inch), a TAVI guidewire desirably provides a flexural modulus of at least 60GPa or 65GPa. That would be similar to that of an Amplatz Super StiffTM or Ultra StiffTM guidewires (0.89mm or 0.035 inch) which were reported in the above referenced article to have a flexural modulus of 60GPa and 65GPa, respectively. For some procedures, the operator may require or prefer a guidewire in the range 60GPa±10%, or alternatively may require a significantly stiffer guidewire. For some procedures, a more flexible guidewire may be preferred.

[027] Where the channel surface comprises one or more grooves along the length of the core wire, the optical fibers and optical sensors preferably sit within the one or more grooves of the core wire without protruding beyond the diameter D_{core} of the core wire. If required, at sensor positions in the distal end portion, the grooves may be enlarged to accommodate the optical sensors. In an embodiment, the channel means comprises a plurality of grooves spaced apart and extending along the length of the core wire. The grooves may be substantially straight along the length of the core wire. In an embodiment, the grooves comprise helical grooves, for example, helical grooves having a pitch of at least 25mm (1 inch). Accordingly, a multisensor guidewire is provided with a grooved core wire that can accommodate multiple fibers and optical sensors while optimizing the stiffness for a guidewire of a particular diameter D_{core} of the core wire and overall outside diameter of the multisensor guidewire.

[028] For measurement of transvalvular pressure gradients, the guidewire comprises two or more optical pressure sensors. For example, it may comprise three sensors. In one embodiment, the first and second optical pressure sensors are located at more distal sensor positions spaced apart by a first distance L_1 and the third optical pressure sensors

being at a more proximal sensor position spaced from the second optical sensor a second distance L_2 , where $L_2 > L_1$. For example L_1 may be about 20mm and L_2 may be about 50mm or 60mm for placement upstream and downstream of the aortic valve, with the two more closely spaced sensors placed in the left ventricle and the other sensor placed in
5 the aorta.

[029] Optionally, the plurality of optical sensors further comprises an optical flow sensor for monitoring blood flow in addition to measurement of blood pressure and blood pressure gradients, e.g. to enable computation of the valve area. In one embodiment, the optical flow sensor is positioned proximally of the pressure sensors, i.e. to measure blood
10 flow in the ascending aorta downstream of the aortic valve and before the branches from the aorta, e.g. about 50mm to 80mm from the aortic valve or a distance L_{FS} of about 20mm upstream from the most proximal optical pressure sensor. Multisensor guidewires of alternative embodiments, comprising other spacings of two or more pressure sensors and a flow sensor, are also disclosed.

15 [030] Beneficially, the plurality of optical sensors further comprises a contact force sensor for monitoring a contact force applied to a length of the distal end portion of the guidewire, e.g. to provide feedback to the interventional cardiologist when a threshold contact force is reached and to assist in avoiding tissue trauma or perforation.

[031] In some embodiments, to accommodate a plurality of optical sensors within a
20 guidewire of diameter $\leq 0.89\text{mm}$ ($\leq 0.035\text{inch}$) and with a core wire providing a required stiffness, the number sensors may be limited to a maximum of two, three or four sensors. For example, for some applications, if only three sensors can be accommodated, it may be preferred to provide two optical pressure sensors and one flow sensor to enable measurements of a transvalvular pressure gradient and blood flow. If a fourth sensor can
25 be accommodated, while still providing sufficient stiffness, it may be another pressure sensor, or a contact force sensor.

[032] Where the multisensor guidewire is to be used as a support guidewire for TVT and similar procedures, to enable over-the-wire delivery of components, the multisensor guidewire comprises separable distal and proximal parts connected by a micro-optical

coupler. The multisensor guidewire forms the distal part and the proximal part comprises a flexible optical coupling to the control system. Thus, distal part comprises a male connector of the optical coupler and the proximal part comprises a female connector of the optical coupler, the male connector having an outside diameter no greater than the
5 outside diameter of the coil of the guidewire. For example, a proximal end of the core wire comprises a tapered portion that extends to form a core of the male connector and the plurality of optical fibers emerge from the grooves and extend around the tapered portion, around the core, and through a surrounding body or ferrule of the male connector which has an outside diameter of no greater than 0.89mm. The optical coupler may
10 further comprise alignment means and/or fastening means.

[033] Beneficially, to assist in anchoring of the guidewire during TVT, e.g. anchoring the guidewire within the left ventricle for TAVI, the flexible distal tip comprises an atraumatic tip such as a J-tip or other pre-formed curved tip. The tip may be a pre-formed three dimensional curved structure, such as a flexible helical structure (resembling a
15 pigtail or coiled phone cord) or a tapered helix resembling a snail shell.

[034] Another aspect of the invention provides a sensor support guidewire apparatus comprising at least one optical sensor, wherein the guidewire comprises a separable micro-optical coupler coupling proximal and distal parts of the guidewire, to enable on/over the guidewire delivery of components. The micro-optical coupler preferably has
20 an outside diameter no larger than the outside diameter of the guidewire coil, e.g. $\leq 0.89\text{mm}$.

[035] Thus in an embodiment, the multisensor support guidewire apparatus for use in TVT, comprises separable distal and proximal parts connected by an optical coupler, wherein

25 the distal part comprises a multisensor support guidewire;

the proximal part comprises a flexible tubular member containing a plurality of optical fibers, and having at its proximal end an optical connector for coupling to the optical controller and having at its distal end the female connector of the optical coupler;

the optical input/output connector at the proximal end of the distal part forming the male part of the optical coupler and having an outside diameter no greater than that of the coil of the guidewire; and

5 the optical coupler providing coupling of the plurality of individual optical fibers of the distal part to respective ones of the plurality of individual optical fibers of the proximal part.

[036] Yet another aspect of the invention provides a sensor guidewire comprising another sensor, e.g. another optical sensor, located within or near a distal end of the guidewire for monitoring a contact force applied to a length of a distal end portion.

10 [037] Thus, in an embodiment, a sensor support guidewire for use in TVT comprises:

a flexible coil having an outside diameter of $\leq 0.89\text{mm}$ and a core wire extending within the coil from a proximal end to a distal end, the distal end comprising a flexible distal tip;

an optical contact force sensor comprising a Fabry-Pérot MOMS optical sensor located within a distal end portion of the guidewire;

15 the Fabry-Pérot MOMS optical sensor being coupled by a first optical fiber to an optical input/output connector at a proximal end of the guidewire for connection to a control system, and a diaphragm of the Fabry-Pérot MOMS optical sensor being coupled to a second optical fiber which extends through a length of the distal end portion for monitoring a contact force applied to said length of the distal end portion;

20 the core wire having a groove defined in its surface along a length of the core wire, the groove accommodating therein the Fabry-Pérot MOMS optical sensor and the first and second optical fibers. A system comprising a sensor guidewire with a contact force sensor allows for a control system to monitor the contact force applied to said length of the distal end portion and provides feedback to the user indicative of the contact force. The
25 system may provide an alert when the contact force exceeds a predetermined threshold value, e.g. during insertion of the support guidewire into the left ventricle for TAVI, to assist the cardiologist in avoiding tissue trauma.

[038] Another aspect of the invention provides a support guidewire for use in TVT having a flexible distal tip comprising a pre-formed three dimensional curved structure. The pre-formed three dimensional curved structure assists in placement and anchoring of the support guidewire in the region of interest. It may comprise a pre-formed helix or a tapered helix resembling a snail shell.

[039] Another aspect of the present invention provides core wire for a sensor guidewire comprising an outer flexible coil wire of outside diameter of 1mm or less, the core wire having a diameter D_{core} to fit within the outer flexible coil wire, and the core wire having a cross-section profiled defining a channel means along a length of the core wire, the channel means comprising part of a surface of the core wire comprising a channel surface recessed within the diameter D_{core} and extending along the length of the core wire for accommodating one or more optical fibers within the diameter D_{core} of the core wire. The core wire preferably comprises a suitable medical grade stainless steel having appropriate mechanical properties for a core wire. In axial cross-section, core wire has a generally circular cross section of outer radius R_1 . The channel surface may be a plurality of straight or helical grooves along the length of the core wire, having dimensions which accommodate one or more optical fibers within the outer radius R_1 of the core wire. In other embodiments, the channel surface may comprise a single groove along the wire for accommodating multiple fibers and sensors, e.g. a core wire having a D-shaped profile formed by grinding a round wire, or a cross-sectional profile defined by wire-rolling or wire-drawing. The groove may be contoured to accommodate multiple fibers. For example, the cross-sectional structure of the wire may be generally circular, having a major portion (circle sector) of outer radius R_1 and a minor portion (circle sector) of outer radius R_2 , where $R_2 < R_1$ and $R_1 - R_2 \geq D_F$ the diameter of the fiber to be accommodated, allowing for a clearance C_L for radii tolerances. The arc or width w of the minor portion is sufficient to accommodate the plurality of fibers side by side circumferentially. In one embodiment, the radius of the boundary or edge between the major and minor portions is defined by a curved surface with an external edge radius R_{ext} which meets a minimum, e.g. 0.005 inch, for formation of the channel surface by known wire rolling and wire drawing processes.

[040] The contoured groove may alternatively be described as comprising ridges and furrows to accommodate the plurality of optical fibers. The ridges and furrows are radiused to position the optical fibers side by side, with centres of the optical fibers at similar radii relative to the centre of the core wire, and with the fibers accommodated
5 within the outer diameter of the core wire. The ridges and furrows are also radiused to meet a minimum requirement for manufacturing by wire rolling or wire drawing. For example, as shown in the cross-sectional view through the guidewire, to accommodate three optical fibers, the groove has two furrows to accommodate two of the fibres and the third fiber rests on ridge in between. Preferably, the center ridge, outer ridges, and
10 furrows are suitably radiused to enable the shape of the channel surface to be manufactured economically using known wire forming processes.

[041] A core wire of this structure can be more readily manufactured using existing wire rolling equipment and thus can be manufactured at a more reasonable cost for use in disposable multisensor guidewires. A core wire of this shape can be used with
15 conventional outer flexible coils. A plurality of small diameter optical fibers can thus be adhesively bonded to the core wire along its length, and accommodated within the inner diameter of the outer flexible coil, while still providing a core wire of a required stiffness. The channel surface may comprise a plurality of grooves along the length of the core wire, each groove accommodating an individual optical fiber. The plurality of grooves
20 may be generally straight, or have some rotation along the length of the core wire, e.g. be helical grooves. Alternatively the channel surface may be a single groove that accommodates the plurality of optical fibers, e.g. side by side. For example, for three optical pressure sensors and three optical fibers, in embodiments of the invention, the core wire has a channel surface having a simple ground groove or a contoured groove,
25 e.g. comprising two furrows and a ridge in between. The channel surface may be generally straight and parallel to the length of the wire, or have some rotation about the axis along the length of the core wire, e.g. depending on manufacturing constraints.

[042] Thus, apparatus, systems and methods are provided that mitigate one or more problems with known systems and apparatus for TVT, and in particular, some
30 embodiments provide a multisensor guidewire which can be used for both TVT

procedures and for direct measurement of hemodynamic parameters such as intravascular or transvalvular pressure gradients and flow, before and after TVT procedures.

[043] The foregoing and other objects, features, aspects and advantages of the present invention will become more apparent from the following detailed description, taken in conjunction with the accompanying drawings, of embodiments of the invention, which description is by way of example only.

BRIEF DESCRIPTION OF THE DRAWINGS

[044] In the drawings, identical or corresponding elements in the different Figures have the same reference numeral.

10 [045] **Fig. 1** illustrates schematically a system according to a first embodiment, comprising a multisensor guidewire apparatus optically coupled to a control unit;

[046] **Fig. 2** illustrates schematically a longitudinal cross-sectional view of an apparatus comprising a multisensor guidewire comprising a plurality of optical sensors according to a first embodiment of the present invention;

15 [047] **Fig. 3** illustrates schematically an enlarged longitudinal cross-sectional view showing details of the distal end portion of the multisensor guidewire illustrated in **Fig. 2**;

[048] **Figs. 4A, 4B, 4C and 4D** show enlarged axial cross-sectional views of the multisensor guidewire illustrated in **Fig. 2** taken through planes A-A, B-B, C-C and D-D respectively;

[049] **Fig. 5A** illustrates schematically a longitudinal cross-sectional view of an apparatus comprising a multisensor guidewire comprising a plurality of optical sensors according to a second embodiment of the present invention;

25 [050] **Fig. 5B** illustrates schematically a longitudinal cross-sectional view of an apparatus comprising a multisensor guidewire comprising a plurality of optical sensors according to a third embodiment of the present invention;

[051] **Fig. 6** illustrates schematically an enlarged longitudinal cross-sectional view showing details of the distal end portion of the multisensor guidewire illustrated in **Fig. 5A**;

[052] **Figs. 7A, 7B, 7C and 7D** show enlarged axial cross-sectional views of the multisensor guidewire illustrated in **5A and 6** taken through planes A-A, B-B, C-C and D-D respectively for a core wire of another embodiment;

[053] **Fig. 8** shows the same cross-section as **Fig. 7B** with some relative dimensions marked;

[054] **Figs. 9A, 9B, 9C and 9D** show enlarged axial cross-sectional views of the multisensor guidewire illustrated in **Figs. 5B** for a core wire of the third embodiment, the view being taken through planes A-A, B-B, C-C and D-D respectively;

[055] **Figs. 10A, 10B, 10C and 10D** show enlarged axial cross-sectional views of core wires of other alternative embodiments, having different cross-sectional profiles;

[056] **Fig. 11A** shows a schematic diagram of a human heart to illustrate placement within the left ventricle of a multisensor guidewire, similar to that shown in **Fig. 2**, for use as: a) a guidewire during a TAVI procedure; and b) for directly measuring a blood pressure gradient across the aortic heart valve before and after the TAVI procedure;

[057] **Fig. 11B** shows a schematic diagram of a human heart to illustrate placement within the left ventricle of a multisensor guidewire, similar to that shown in **Fig. 5**, for use as: a) a guidewire during a TAVI procedure; and b) for directly measuring a blood pressure gradient across the aortic heart valve before and after the TAVI procedure, wherein a flow sensor is provided for measuring blood flow upstream of the aortic valve.

[058] **Figs. 12A, 12B and 12C** show corresponding schematics of a human heart illustrating three potential approaches for placement of the multisensor guidewire of **Fig. 5** through the mitral valve, for use as: a) a support guidewire during a TAVI procedure; and b) as a diagnostic tool for directly measuring a blood pressure gradient across the heart valve before and after the TAVI procedure;

[059] **Fig. 13** shows a corresponding schematic of a human heart illustrating placement of the multisensor guidewire through the tricuspid valve, for use as: a) a guidewire during a TVT procedure; and b) for directly measuring a blood pressure gradient across the heart valve before and after the TVT procedure;

5 [060] **Fig. 14** shows a corresponding schematic of a human heart illustrating placement of the multisensor guidewire through the pulmonary valve, for use as: a) a guidewire during a TVT procedure; and b) for directly measuring a blood pressure gradient across the heart valve before and after the TVT procedure;

[061] **Fig. 15** shows a chart, known as a Wiggers diagram, showing typical cardiac
10 blood flow and pressure curves during several heart cycles, for a healthy heart;

[062] **Figs. 16A, 16B** and **16C** show simplified schematics representing the aortic heart valve and left ventricle in a healthy heart, with the multisensor guidewire inserted through the aortic valve with first and second optical pressure sensors P1 and P2 positioned within the ventricle and the third optical pressure sensor P3 positioned within
15 the aorta for measurement of a transvalvular pressure gradient through the aortic valve in a healthy heart, with the heart valve in closed, semi-closed/open and open positions respectively;

[063] **Figs. 17A, 17B** and **17C** show similar simplified schematics representing the aortic heart valve and left ventricle, in which shaded areas represent stenoses, with the
20 multisensor guidewire inserted through the aortic valve with first and second optical pressure sensors P1 and P2 positioned within the ventricle and the third optical pressure sensor P3 positioned within the aorta for measurement of a transvalvular pressure gradient through the aortic valve in a diseased heart, with the heart valve in closed, semi-closed/open and open positions respectively;

25 [064] **Fig. 18** shows a chart showing typical variations to the blood flow or pressure curves, during several cardiac cycles, due to cardiac stenosis;

[065] **Fig. 19** illustrates schematically a view of the male and female connectors of the micro-optical coupler for optically coupling the distal and proximal parts of the multisensor guidewire;

[066] **Fig. 20** illustrates schematically an enlarged longitudinal cross-sectional view of the male part of the multisensor guidewire optical connector illustrated in **Fig. 19**;

[067] **Figs. 21A, 21B, 21C and 21D** show enlarged axial cross-sectional views of the multisensor guidewire optical connector illustrated in **Fig. 20** taken, respectively, through planes A-A, B-B, C-C and D-D indicated in **Fig. 20**;

[068] **Fig. 22** illustrates schematically a side perspective view an optical contact force sensor (strain gauge) for use in a multisensor guidewire for cardiovascular use such as for TVT;

[069] **Fig. 23** illustrates a longitudinal cross sectional view of the optical contact force sensor (strain gauge) of **Fig. 22**;

[070] **Fig. 24** illustrates schematically a longitudinal cross-sectional view showing details of the distal end portion of a multisensor guidewire of a third embodiment comprising a contact force sensor such as illustrated in **Fig. 22**;

[071] **Figs. 25A and 25B** show enlarged axial cross-sectional views of the multisensor guidewire comprising a contact force sensor illustrated in **Fig. 23** taken, respectively, through planes A-A and B-B indicated in **Fig. 24**;

[072] **Fig. 26** shows a schematic diagram of a human heart to illustrate placement within the left ventricle of a multisensor guidewire, similar to that shown in **Fig. 23**, for sensing a contact force, e.g. during a TAVI procedure or during measurement of cardiovascular parameters before, during and after the TAVI procedure;

[073] **Figs. 27A and 27B**, show enlarged views of the distal end of a guidewire wherein the tip comprises pre-formed helical tip of a first embodiment;

[074] **Fig. 28** shows a schematic diagram of a human heart to illustrate placement of within the left ventricle of a guidewire comprising a flexible pre-formed helical tip as shown in **Figs. 27A** and **27B**;

[075] **Figs. 29A** and **29B** show enlarged views of views of the distal end of a guidewire wherein the tip comprises a pre-formed helical tip of another embodiment; and

[076] **Fig. 30** shows a schematic diagram of a human heart to illustrate placement within the left ventricle of a multisensor support guidewire, comprising a pre-formed helical tip as shown in **Figs. 29A** and **29B**.

DETAILED DESCRIPTION OF EMBODIMENTS

10 [077] A system and apparatus comprising a multisensor guidewire for use in interventional cardiology, which may include diagnostic measurements of cardiovascular parameters and/or TAVI, according to an embodiment of the present invention will be illustrated and described, by way of example, with reference to a system for use in a TAVI procedure, for aortic valve replacement.

15 [078] Firstly, referring to **Fig. 1**, this schematic represents a system **1** comprising an apparatus **100** comprising a multisensor guidewire for use in TAVI procedures, coupled to a control system **150**, which houses a control unit **151** and user interface, such as the illustrated touch screen display **152**. The apparatus **100** comprises a proximal part **101** and distal part **102**. The distal part **102** takes the form of a multisensor guidewire and
20 comprises components of a conventional guidewire comprising an outer layer in the form of a flexible fine metal coil **35** and an inner mandrel or core wire **31** within the outer coil **35**. The outer coil **35** and the core wire **31** each have a diameter and mechanical properties to provide the required stiffness to act as a “support guidewire” for TAVI, i.e. for over-the-wire delivery of a replacement valve. Typically, for TAVI, the coil has an
25 outside diameter of 0.035 inch or 0.89mm or less, the guidewire has a suitable stiffness for transcatheter or intra-vascular insertion, and extends to distal tip **120**, such as a flexible J-tip, or other atraumatic curved tip, to facilitate insertion. To provide the appropriate stiffness and mechanical properties, coil **35** and core wire **31**, are typically stainless steel, although other suitable metals or alloys may alternatively be used. The

distal part **102** differs from a conventional guidewire in that internally, it also contains a sensor arrangement **130** (not visible in **Fig. 1**) comprising a plurality of optical sensors **10**, i.e. **10a, 10b and 10c**, located within a length **L** of the distal end portion **103**, near the distal tip **120**. For example, as will be described in detail with reference to **Figs. 2** and **3**, three optical sensors may be provided in the distal end portion **103** spaced by distances **L₁** and **L₂**. Thus, internally, the distal part **102** also provides optical coupling of the optical sensors, through a plurality of optical fibers **11**, to an optical coupler **140** at its proximal end, as will also be described in detail with reference to **Figs. 2, 3, 4A, 4B, 4C** and **4D**.

[079] The proximal part **101** of the apparatus **100** provides for optical coupling of the distal part **102** to the control unit **151**. The proximal part **101** has at its proximal end **110** an optical input/output **112**, such as a standard type of optical fiber connector which connects to a corresponding optical input/output connector **153** of the control unit **151**. Thus the proximal part **101** is effectively an elongate, flexible optical coupler, e.g. a tubular flexible member containing a plurality of optical fibers, with the optical coupler **140** at its distal end for optical coupling of the distal part **102**, i.e. the multisensor guidewire. The control unit **151** houses a control system comprising a controller with appropriate functionality, e.g. including an optical source and an optical detector, a processor, data storage, and optical source and optical detector, and provides a user interface, e.g. a keypad **154**, and touch screen display **152**, suitable for tactile user input, and for graphical display of sensor data. The user interface cable **155** (typically a standard USB cable) is used to transfer data between the control unit **151** to the touch screen display **152**.

[080] The internal structure of the multisensor guidewire apparatus **100** will now be described in more detail with reference to **Figs. 2** and **3**.

[081] **Fig. 2** illustrates schematically a longitudinal cross-sectional view of the apparatus **100** according to the first embodiment of the invention, comprising a multisensor guidewire. The apparatus **100** extends from the optical input/output connector **112** at the proximal end **110** through the proximal part **101** to the distal part

102 which extends to the distal tip **120**. If required, the outer coil of guidewire may have a coating of a suitable biocompatible hydrophobic coating such as PTFE or silicone.

[082] The distal part **102** takes the form of a multisensor guidewire and comprises components of a conventional guidewire comprising an outer layer in the form of a flexible fine metal coil **35** and an inner mandrel or core wire **31** within the outer coil **35**.
5 The outer coil **35** and the core wire **31** each have a diameter and mechanical properties to provide the required stiffness to act as a guidewire for TAVI. Typically, for TAVI, the coil has an outside diameter of 0.035 inch or 0.89mm or less. To provide the appropriate stiffness and mechanical properties, coil **35** and core wire **31**, are typically stainless steel,
10 although other suitable metals or alloys may alternatively be used.

[083] In this embodiment, the sensor arrangement **130** (not visible in **Fig. 2**) comprises a plurality of optical sensors, i.e. three optical pressure sensors **10a**, **10b**, **10c** arranged along a length **L** of a distal end portion **103** near the distal tip **120**. Each of the optical pressure sensors is optically coupled to a respective individual optical fiber **11**.
15 Optionally, another type of optical sensor, e.g. an optical flow sensor **20**, may be provided in or near the distal end portion **103**, and coupled to another respective optical fiber **11**.

[084] For example, for measuring a transaortic pressure gradient, the optical pressure sensors **10a**, **10b**, **10c** are arranged spaced apart by distances L_1 and L_2 , e.g. 20mm and
20 50mm to 60mm respectively, for placement of the sensors upstream and downstream of the aortic valve. Optionally, a flow sensor **20** (see **Figs. 2** and **5B**) is positioned to measure flow in the aorta before the main branches from the aorta, e.g. in the ascending aorta, about 50mm to 80mm downstream of the aortic valve **511** or a distance L_{FS} of about 20mm from the nearest pressure sensor **10b** or **10c** (see **Figs. 2**, **5B**, **11A** and **11B**).

[085] To accommodate the plurality of optical sensors **10a**, **10b**, **10c** and **20** and their respective optical fibers **11** while maintaining the required stiffness to the guidewire, the core wire is provided with a corresponding plurality of helical grooves **32**. The helical grooves **32** extend along the length of the core wire **31** from the optical coupler **140** to
25 near the distal tip **120**. The helical grooves **32** are sized to accommodate the optical fibers

along the length of the distal part **102** and accommodate the optical sensors at sensor locations spaced apart along the length **L** of the distal end portion **103**, as shown in more detail in **Fig. 3**.

[086] **Fig. 3** shows an enlarged longitudinal cross-sectional view of the distal end portion **103** of the multisensor guidewire **100** illustrated in **Fig. 2**. As illustrated, the multisensor guidewire **100** is capable of measuring blood pressure simultaneously at several points, in this case three points, using the three optic fiber-based pressure sensors **10a**, **10b**, **10c** arranged along the length **L** of the distal end portion **103** of the multisensor guidewire. For TAVI, the sensor locations are arranged to allow for the optical pressure sensors to be placed upstream and downstream of the aortic valve during measurements.

[087] Accordingly, in this embodiment, the two more distal sensors **10a** and **10b** are spaced apart by a distance L_1 and sensors **10b** and **10c** are spaced apart by a distance L_2 , where $L_2 > L_1$. The dimensions and pitch/angle of the helical grooves **32** in the surface of the core wire **31** are selected to accommodate the fibers **11** in channels between the core wire **31** and coil **35**. Preferably, the grooves are sized so that the optical sensors **10a** and **10b** and the optical fibers **11** do not protrude beyond the external diameter of the core wire **31**. Each sensor and optical fiber may be fixed to the core wire, e.g. adhesively fixed to the core wire, at one or more points. For example, during assembly, optical fibers **11** are inserted into the grooves **32** and held in place in the grooves **32** in the core wire **31**, e.g. with a suitable biocompatible and hemocompatible adhesive, before the core wire is inserted into the coil wire **35**. To accommodate the sensors **10a**, **10b**, **10c** and **20**, which may be larger in diameter than the optical fibers **11** themselves, if required, each groove **32** may be enlarged in the region where the sensor is located, i.e. at each sensor location. The guidewire coil **35** may be more loosely coiled, or otherwise structured, in the distal end portion **103** to provide apertures **36** between the coils of the wire of the guidewire coil near each of the optical pressure sensors that allow for fluid contact with the optical pressure sensors **10** (i.e. **10a**, **10b**, **10c**).

[088] Also, a marker, such as a radiopaque marker **14** is provided near each sensor, e.g. placed in the helical groove **32** distally of the sensor, to assist in locating and positioning the sensors in use, i.e. using conventional radio-imaging techniques when introducing the

guidewire and positioning the sensors in a region of interest, e.g. upstream and downstream of the aortic valve. The radiopaque markers **14** are preferably of a material that has a greater radiopacity than the material of the core wire. For example, if the core wire **31** and outer coil **35** are stainless steel, a suitable heavy metal is used as a radiopaque marker, e.g. barium or tantalum. If required, the guidewire may have a coating of a suitable biocompatible hydrophobic coating such as PTFE or silicone.

[089] **Figs. 4A, 4B, 4C and 4D** show enlarged axial cross-sectional views of the multisensor guidewire **100** taken through planes A-A, B-B, C-C and D-D respectively, of **Fig. 2**. **Fig. 4A** shows the optical fibers **13** with tubing **51** and jacket **52** of the proximal part **101**. **Figs. 4B, 4C and 4D** show the core wire **31** within the outer coil **35** to illustrate the location of the optical fibers **11** in grooves **32**, and the location of pressure sensors **10a, 10b, 10c** within enlarged groove portion **34** of the grooves **32** in the core wire **31**.

[090] Since the optical fibers do not contribute significantly to the stiffness of the guidewire, for superior stiffness required for a support guidewire of a given outside diameter, e.g. 0.89mm, the outside diameter core wire is preferably as large as can be reasonably be accommodated within the inside diameter of the outer coil of the guidewire, allowing the required clearance between the core wire and the outer flexible coil. Accordingly, the helical grooves **32** in the core wire preferably have a minimal size to accommodate the optical fibers and sensors within the grooves and within the diameter **D_{core}** of the core wire. In this context, by convention, the wire gauge or diameter **D** of a wire refers to the diameter **D** of the circle into which the wire will fit. It will be appreciated that the maximum diameter **D_{core}** must also fit within the inside diameter of the outer flexible coil of the guidewire, with an appropriate clearance between the core wire and optical fibers and sensors and the coil, which is, for example, at least 1 mil or 25 microns.

[091] The helical form of the grooves **32** reduces longitudinal and point stresses/strains in the individual fibers when the guidewire is flexed. For example, if the grooves were straight along the length of the fiber, when the guidewire is flexed, fibers on the inside curve of the bend would be subject to more compressive forces and fibers on the outside of the curve would be subject to more tensile forces. While the ends of the fibers and the

sensors may be adhesively fixed to the core wire within the grooves **32**, or at one or more intermediate points, when the guidewire is flexed, the helical structure of the grooves tends to spread compressive and tensile forces over a length of each fiber and reduces localized stresses and strains. Desirably, to optimize the core wire stiffness relative to the outside diameter of the guidewire, i.e. of the outer coil, there is a minimal required spacing between the core wire **31** and the coil **35** and so the helical grooves accommodate the optical fibers and sensors without protruding beyond the diameter D_{core} of the core wire, as illustrated in the schematic cross-sectional view shown in **Fig. 4B**. As mentioned above, if needed, the grooves are enlarged to form a recess or cavity **34** in the sensor locations, as illustrated schematically in **Figs. 4C** and **4D**. **Fig. 4A** shows a corresponding cross-sectional view through the proximal portion **101**, which comprises the bundle of optical fibers **13** contained within flexible tubing **51** and jacket **52**.

[092] Since the proximal part **101** simply provides a flexible optical coupling to the control unit **150**, it does not have the same stiffness as the distal part **102** comprising the guidewire, and thus does not need to include a core wire. Although in **Fig. 2** the structure of the multisensor assembly is shown in cross-section along its length from the connector **112** to the distal tip **120**, for simplicity, the internal structure of the connector **112** is not shown. It will be appreciated that the optical fibers **13** of the proximal part **101** extend through the connector **112** to optical inputs/outputs **113** of the connector, as is conventional.

[093] The optical pressure sensors **10a**, **10b** and **10c** are preferably Fabry-Pérot Micro-Opto-Mechanical-Systems (FP MOMS) pressure sensors. As an example, a suitable commercially available FP MOMS pressure sensor is the Fiso FOP-M260. These FP MOMS sensors meet specifications for an appropriate pressure range and sensitivity for blood pressure measurements. They have an outside diameter of 0.260mm (260 μ m). Typically, they would be coupled to an optical fiber with an outside diameter of 0.100 (100 μ m) to 0.155mm (155 μ m). Accordingly, the helical grooves would have a depth of 0.155mm along their length with an enlarged depth of 0.260mm at each sensor location. The pitch of the helical grooves is 25mm (1 inch) or more to reduce stress on the optical fibers.

[094] The optional optical flow sensor **20** preferably comprises an optical thermoconvection flow sensor, e.g. as described in United States patent application no. 14/354,588.

[095] As illustrated schematically in **Figs. 4B to 4D**, assuming the coil **35** has an
5 outside diameter of 0.89mm (0.035 inch) including any coating, and is formed from 0.002 inch thick coil wire, to provide an inside diameter of about 0.787mm (0.031 inch), then a core wire having a maximum outside diameter of about 0.736mm (0.029 inch) could be accommodated within. Preferably the coil and the core of the guidewire are made from stainless steel having high stiffness, e.g. 304V stainless steel, or other types of
10 stainless steel for medical applications. Other biocompatible metal alloys with suitable mechanical characteristics may alternatively be used.

[096] The helical grooves **32** will somewhat reduce the stiffness of the core wire relative to a conventional cylindrical core wire structure, but the grooved core wire structure accommodates multiple optical fibers and sensors while optimizing the stiffness
15 for a given diameter guidewire.

[097] By comparison, to accommodate a plurality of similarly sized optical fibers and sensors in a cylindrical space between a conventional core wire and the outer coil, the core wire diameter would have to be reduced to about 0.5mm to accommodate the fibers, and even further reduced in the sensor locations to accommodate the sensors. Since the
20 stiffness of a core wire varies as the fourth power of the diameter, such a reduction in the core wire diameter significantly reduces the stiffness of the guidewire. While the helical grooves in the core will somewhat reduce the stiffness of the core wire, they will do so by a far less significant factor than using a smaller diameter core wire.

[098] When helical grooves are provided to accommodate the fibers and the optical
25 sensors, and the pitch of the helix may be 25mm (1 inch) or more, for example. In alternative embodiments (not illustrated) the grooves in the guidewire run straight along the length of the guidewire.

[099] The multisensor support guidewire apparatus **100** is preferably also capable of measuring blood flow, since quantification of blood flow restriction is related to the

pressure difference/gradient and the blood flow velocity. Thus, optionally, it includes an integral fiber-optic flow sensor **20** (see **Figs. 2** and **5B**) at a suitable position in or near the distal end portion **103** to measure the blood flow velocity. The optical flow sensor may for example comprise an optical thermoconvection sensor or other suitable optical flow sensor.

[100] The guidewire coil **35** together with the mandrel or core wire **31** provide the torquable characteristics of the multisensor guidewire **100** so that is capable of being shaped or flexed to traverse vascular regions in the same manner as a conventional guidewire.. To facilitate insertion, the distal tip **120** extends beyond the distal end portion **103** containing the pressure sensors **10a**, **10b**, **10c** and optional flow sensor **20**, and the tip **120** may be a flexible pre-formed J tip or other appropriate atraumatic tip such as a resiliently deformable or flexible curved tip which is preformed or can be manually shaped. Typically the tip is contiguous with the guidewire. That is, the fine wire coil **35** extends along the length of the tip to a rounded end, and the core wire **31** is thinned within the tip to increase the flexibility of the tip relative to the main part of the support guidewire **102**. The tip **120** may comprise a coating that can be pre-formed into a desired curved shape, e.g. a thermoplastic coating that can be thermoformed into a desired shape. The core wire **31** has a maximum possible diameter within the coil **35** within distal end portion **103** that contains the sensors (e.g. see **Figs. 4B**, **4C**, and **4D**) so that the distal part **102** of the guidewire has sufficient stiffness to act as a support guidewire for TVT.

[101] For operation of the optical sensors, the micro-coupler **140** couples the distal part **102** forming the multisensor guidewire to the proximal part **101** which provides optical coupling to the control unit **151** for controlling operation of the optical sensors **10** and **20**. The proximal part **101** simply provides a flexible optical coupling of the distal part of the guidewire **102** to the control unit **151**. Thus the proximal part **101** can have any suitable diameter and flexibility. It is not required to have guidewire elements, i.e. a coil **35** and core wire **31** to provide specific mechanical properties of a guidewire. Thus the proximal part may be more similar to a lower cost optical fiber cable, e.g. a bundle of plurality of optical fibers **13** enclosed within a tubular covering layer **51**, e.g. single layer or multilayer tubing similar to catheter tubing. If required, it is protected by a thicker

protective outer jacket or sleeve **52** for mechanical strength/reinforcement and to facilitate handling. The optical fibers **13** in the proximal part are optically coupled to connector **112** at the proximal end **110** and to micro optical coupler **140** at the distal end.

[102] The optical fibers **11** in the distal part **102** reduce the cross-section area of the core wire **31** therefore significantly reducing stiffness of the guidewire **102**. It will be appreciated that the use of specialized higher cost optical fibers **11** with a smaller diameter improves the stiffness of the guidewire **102**. While, the use of standard lower cost optical fibers **13** with a larger diameter, e.g. optical fibers used for telecommunication, in the proximal part **101** reduces the guidewire **100** total cost without limiting its capabilities and performance for TVT procedures.

[103] A multisensor guidewire **200** of a second embodiment is illustrated in **Fig. 5A**. Many elements of the multisensor guidewire **200** are similar to those of the multisensor guidewire **100** illustrated in **Figs. 2** and **3** described above, and like parts are numbered with the same reference numeral. However, in this embodiment, the core wire **31** has a cross-sectional profile which comprises a channel surface **132** in the form of a contoured or grooved structure along its length to provide a guidewire having an axial cross-section as illustrated in **Fig. 7B, 7C and 7D**. The grooved structure **132** accommodates a plurality of sensors **10a, 10b, 10c** coupled to respective optical fibers **11**, within the diameter D_{core} of the core wire.

[104] Referring to **Fig. 5A**, the apparatus **200** comprises a proximal part **101** and distal part **102**. The distal part **102** takes the form of a multisensor guidewire and comprises components of a conventional guidewire comprising an outer layer in the form of a flexible fine metal coil **35** and an inner mandrel or core wire **31** within the outer coil **35**. The outer diameter and mechanical properties of both the outer coil **35** and the core wire **31** are selected to provide the required stiffness to act as a guidewire for TAVI. Typically, for TAVI, the coil has an outside diameter of 0.035 inch or 0.89mm or less, the guidewire has a suitable stiffness for transcatheter or intra-vascular insertion, and extends to distal tip **120**, such as a flexible J-tip, or other atraumatic curved tip, to facilitate insertion. To provide the appropriate stiffness and mechanical properties, coil

35 and core wire **31**, are typically stainless steel, although other suitable metals or alloys may alternatively be used.

[105] The distal part **102** contains a sensor arrangement comprising a plurality of optical sensors **10a**, **10b**, **10c** located within a length **L** of the distal end portion **103**, near the distal tip **120**. Internally, the distal part **102** provides optical coupling of the optical sensors, through a plurality of optical fibers **11**, to an optical coupler **140** at its proximal end, as will also be described in detail with reference to **Figs. 6, 7A, 7B, 7C** and **7D**.

[106] The proximal part **101** of the apparatus **200** provides for optical coupling of the distal part **102** to the control unit **151** (e.g. see **Fig. 1**). The proximal part **101** has at its proximal end **110** an optical input/output **112**, such as a standard type of optical fiber connector which connects to a corresponding optical input/output connector port **153** of the control unit **151**. Thus the proximal part **101** is effectively an elongate, flexible optical coupler, e.g. a tubular flexible member containing a plurality of optical fibers, with the optical coupler **140** at its distal end for optical coupling of the distal part **102**, i.e. the multisensor guidewire.

[107] As shown in more detail in the enlarged longitudinal cross-sectional view in **Fig. 6** the three optical sensors **10a**, **10b** and **10c**, coupled to respective optical fibers, are located in the distal end portion **103**, near the distal tip **120**. The sensors **10a**, **10b** and **10c** are spaced by distances L_1 and L_2 . Also, a marker, such as a radiopaque marker **14** is provided near each sensor, to assist in locating and positioning the sensors in use, i.e. using conventional radio-imaging techniques when introducing the guidewire and positioning the sensors in a region of interest, e.g. upstream and downstream of the aortic valve. The radiopaque markers **14** are preferably of a material that has a greater radiopacity than the material of the core wire. For example, if the core wire **31** and outer coil **35** are stainless steel, a suitable heavy metal is used as a radiopaque marker, e.g. barium or tantalum. If required, the outer coil of guidewire may have a coating of a suitable biocompatible hydrophobic coating such as PTFE or silicone.

[108] For example, for measuring a transaortic pressure gradient, the optical pressure sensors **10a**, **10b**, **10c** are arranged spaced apart by distances L_1 and L_2 , e.g. 20mm and

60mm respectively, for placement of the sensors upstream and downstream of the aortic valve. Optionally, a flow sensor **20** (see **Fig. 2**) is positioned to measure flow in the aorta before the main branches from the aorta, e.g. in the ascending aorta, about 50mm to 80mm downstream of the aortic valve **511** or a distance L_{FS} of about 20mm from the
5 nearest pressure sensor **10b** or **10c** (see **Figs. 2, 5B, 11A** and **11B**).

[109] Alternatively, as illustrated in **Fig. 5B**, a guidewire **300** of a third embodiment when three optical sensors can be fitted within the required diameter, the sensors comprise two optical pressure sensors **10a** and **10b**, and a flow sensor **20**, proximal to the pressure sensors **10a** and **10b**. This embodiment will be described in more detail
10 below with reference cross-sectional views shown in **Figs. 9A, 9B, 9C** and **9D**.

[110] Referring back to the multisensor guidewire **200** of the second embodiment shown in **Fig. 5A**, the optical pressure sensors **10a, 10b, 10c** and their respective optical fibers **11** lie in the grooved structure **132** as illustrated schematically in the cross-sectional views shown in **Figs. 7B, 7C** and **7D**. To accommodate optical sensors **10a, 10b, 10c** and their respective optical fibers **11**, while maintaining the required stiffness to the guidewire, the core wire has a grooved structure **132** as shown in the axial cross-sectional views in **Figs. 7B, 7C** and **7D**. The grooved structure **132** extends along the
15 length of the core wire **31** from the optical coupler **140** to near the distal tip **120**.

[111] The dimensions of the grooved structure **132** in the surface of the core wire **31** are
20 selected to accommodate the fibers **11** in between the core wire **31** and coil **35**. Preferably, the grooved structure **132** is sized so that the optical pressure sensors **10a, 10b, 10c** and the optical fibers **11** do not protrude beyond the external diameter D_{core} of the core wire **31** (see **Figs. 7B, 7C** and **7D** for example). Each sensor and optical fiber may be fixed to the core wire, e.g. adhesively fixed to the core wire, at one or more
25 points. For example, during assembly, optical fibers **11** are adhesively attached to the core wire **31**, e.g. with a suitable biocompatible and hemo-compatible adhesive **39**, before the core wire is inserted into the coil wire **35**. To accommodate the sensors **10a, 10b, 10c**, which may be larger in diameter than the optical fibers **11** themselves, if required, the grooved structure may be enlarged in the region where the sensors **10a, 10b, 10c** are located, i.e. at each sensor location. For example a cavity or recess **34** is ground
30

in the core wire, as shown schematically in **Figs. 6, 7C and 7D**, to provide space for the sensors **10a, 10b, 10c** and a radiopaque marker **14**. The guidewire coil **35** may be more loosely coiled, or otherwise structured, in the distal end portion **103** to provide apertures **36** between the coils of the wire of the guidewire coil near each of the optical pressure sensors that allow for fluid contact with the optical pressure sensors **10a, 10b, 10c**.

[112] **Figs. 7A, 7B, 7C and 7D** show enlarged axial cross-sectional views of the multisensor guidewire **200** taken through planes A-A, B-B, C-C and D-D respectively, of **Fig. 5A**. **Fig. 7A** shows the optical fibers **13** with tubing **51** and jacket **52** of the proximal part **101**. **Figs. 7B, 7C and 7D** show the core wire **31** within the outer coil **35** to illustrate the location of the optical fibers **11** in grooved structure **132**, and the location of pressure sensors **10b, 10c** within enlarged groove portion or cavity (recess) **34** in the core wire **31**. As shown in **Fig. 7C and 7D**, where the groove portion is enlarged to accommodate the sensors, the core wire has a lune-shaped cross-section.

[113] Referring to **Fig. 8**, since the optical fibers do not contribute significantly to the stiffness of the guidewire, for superior stiffness required for a guidewire of a given outside diameter, e.g. $\leq 0.89\text{mm}$ (0.035 inch), the diameter core wire is preferably as large as can be reasonably be accommodated within the outer coil of the guidewire (e.g. .029 inch) for a coil wire of 0.002 inch x 0.012 inch. As illustrated schematically, if, for example, the optical fibers are of 0.100mm (0.0039 inch) diameter, the grooved structure **132** in the core wire is sized accordingly to accommodate the three optical fibers **11** side by side, in the space or channel left between the core wire **31** and outer coil **35**. For example, for a 0.029 inch diameter core wire $R_1 = 0.0145$ inch, the inner radius R_2 of the grooved part of the guidewire be 0.009 inch, so as to accommodate optical fibers **11** of 0.100mm (0.0039 inch) diameter, and adhesive **39** for bonding the fibers to the core wire, without protruding beyond the diameter D_{core} of the core wire, as illustrated in **Fig. 7C**. The width w of the groove structure allows for the three fibers to lie side by side. The depth and contouring of the grooved structure is sufficient to accommodate the diameter of the fibers D_F within the diameter D_{core} of the core wire. A core wire of this embodiment is more readily manufactured using known wire rolling or wire drawing processes. A single grooved structure for multiple optical fibers and sensors also

facilitates assembly of the optical sensors, optical fibers and the core wire, e.g. by adhesive bonding to the core wire. The assembly of the core wire and optical sensors and their respective optical fibers may then be inserted into the outer flexible coil of the guidewire.

5 [114] **Figs. 9A, 9B, 9C and 9D** show enlarged axial cross-sectional views of the multisensor guidewire illustrated in **Fig. 5A**, comprising a core wire **31** of a third embodiment, taken through planes A-A, B-B, C-C and D-D respectively. The multisensor guidewire in this embodiment comprises 3 optical fibers **11**, two optical pressure sensors **10a, 10b** and one optical flow sensor **20**. Compared with the core wire
10 shown in **Figs. 7A, 7B, 7C and 7D**, the core wire **31** shown in **Figs. 9A, 9B, 9C and 9D** has a simpler cross-sectional profile comprising a channel surface **132**, i.e. a groove or facet, along one side of the core wire **31** to provide a channel **33** between the core wire **31** and the outer coil **35**. For example, the channel surface **132** is formed by grinding a round wire, or by wire drawing, could be described as having a generally D-shaped
15 cross-sectional profile. That is, as shown in **Fig. 9A**, the core wire is generally circular, having an outer diameter that fits within the outer flexible coil. Geometrically, the cross-sectional profile of the core wire thus has the form of the major segment of a circle, wherein the channel surface **132** is defined by a chord of the circle. The resulting space or channel **33** for the fibers and enlarged portion **34** for the sensors, that is, formed
20 between the core wire and the inner diameter of the outer flexible coil, has a cross-sectional profile defined by the minor segment of the circle.

[115] The groove structure **32** may be substantially flat as illustrated, or may be contoured, e.g. with a convex profile or concave profile (see e.g. **Figs. 7C and 7D**). In this embodiment, the groove **32** in the core wire **31** is sized to accommodate the three
25 optical fibers **11** for the optical sensors **10a, 10b** and **20**, within space **33**. If required, optical sensors **10a, 10b** and **20** are located within enlarged groove portions at sensor locations, e.g. a cavity or recess **34** in the core wire **31**, such as illustrated in **Figs. 7C and 7D**.

[116] **Figs. 10A, 10B, 10C and 10D** show core wires **31** of other alternative
30 embodiments, having other cross-sectional profiles where channel surfaces **132** defining

the grooves are contoured, e.g. by wire rolling or wire drawing processes, to form channels **33** within the diameter D_{core} of the core wire. Each channel **33** may accommodate one or more optical fibers and respective optical sensors. As illustrated, and as mentioned above, in this context, for a wire with a cross-section that is not entirely
5 circular, the diameter D_{core} of the core wire refers to the diameter of the circle into which the wire will fit.

[117] As described above, core wires according to some embodiments of the invention comprise a channel surface in the form of multiple grooves, each groove accommodating a single fiber and optical sensor. In other embodiments, one or more channel surfaces
10 defining one or more larger grooves are provided, each groove accommodating two or more fibers and optical sensors. Preferably, the optical fibers and their respective optical sensors are accommodated within the groove and within the diameter D_{core} of the core wire (see **Figs. 4B, 8 and 9A** for example). To facilitate fabrication, this enables the optical fibers carrying the optical sensors to be fixed to the core wire, e.g. by adhesively
15 bonding the fibers to the channel surface(s) of the core wire, to form an assembly of the core wire and the plurality of optical fibers and optical sensors, with the optical sensors appropriately spaced apart and positioned at the required sensor locations. Then, the assembly of the core wire, fibers and optical sensors can be inserted into the outer flexible coil.

20 [118] **Optical micro-coupler**

[119] As illustrated in **Fig. 19**, the micro-coupler **140** comprises male and female parts, **142** and **144** respectively, to provide for optical coupling of each optical pressure sensor **10a, 10b, 10c** and optical flow sensor **20** via their respective individual optical fibers **11** of the distal part **102** to respective individual fibers **13** of the proximal part **101**. Notably,
25 the male portion **142** of the micro-optical coupler has the same outside diameter D as the coil **35** of the guidewire to enable components for TVT to be mounted on or over the guidewire. The female portion **144** of the micro-optical coupler is of larger diameter and may be formed to act as a hub **44** that can be grasped facilitate handling and torque steering of the guidewire, and as well as to facilitate engaging and disengaging distal part
30 **102**. An alignment means, such as facet **43** of the male part **142**, which aligns to a

corresponding facet (not visible) in the female part **144** ensures that individual fibers **11** are indexed, aligned and correctly optically coupled to respective corresponding individual fibers **13** for optical data communication. The connector **140** may also include a suitable fastening means for securely attaching and locking/unlocking the two parts **142** and **144** of optical coupler **140**.

[120] For example, the sensor guidewire may be unlocked from the proximal part, to remove the attachment of the guidewire to the control console (control unit **151**). Then a catheter, or other component, can be inserted over the multisensor guidewire **102**. Then the sensor guidewire is recoupled to the control console to perform pressure and flow measurements. This provides ease of use for insertion of catheters, balloons, valve delivery catheters, or other required components.

[121] **Fig. 20** shows a cross-sectional view of the proximal end of distal part/guidewire **102** showing the internal structure of the male part **142** of connector **140**. As illustrated schematically, the core wire **31** is tapered to form a core **37** at its end that inserts into the ferrule **42** of connector part **142** so that the individual optical fibers **11** are guided from the grooves **32** in the core wire **31** into and through the ferrule **42** of the connector part **142**. The internal structure of the male connector part **142** is shown through cross-section through A-A, B-B, C-C and D-D in subsequent **Figs. 21A, 21B, 21C and 21D**

[122] Notably, the micro-coupler **140** provides for disengagement of the distal part **102** from the proximal part **101** of the guidewire. Moreover, the male part **142** has the same outside diameter **D** as the coil **35** of the multisensor guidewire. Thus, the distal part **102** functions as a conventional support guidewire, in that, components such as a replacement valve and delivery system, or other components, can be mounted on/over the guidewire for guiding and delivery into the heart.

[123] The female part **144** of the micro-connector **140** may have an outer hub **44** of larger diameter to facilitate handling, alignment and connection of the micro-coupler **140**.

[124] Although a single optical connector **112** is shown for the input/output for each of the optical fibers **13**, in other embodiments, an alternative connector or coupling arrangement may be provided. The multisensor wire connector **112** and the control unit

port **153** may comprise several individual optic fiber connectors, instead of a single multi-fiber connector. The connector **112** may optionally include circuitry allowing wireless communication of control and data signals between the multisensor wire **100** and the control unit **151**. Optionally one or more electric connectors for peripheral devices, or for additional or alternative electrical sensors, may be provided.

[125] Referring to **Fig. 11A**, this shows schematically the placement of the distal end portion **103** of the guidewire **102** within the left ventricle **512** in the human heart **500**. For TAVI procedures, the distal tip **120** is preferably of a suitable structure, such as a flexible and specially curved tip or J-tip, to assist in firmly anchoring the distal end of the guidewire in position in the ventricle, without causing trauma to the ventricular wall, the valve, or other tissues within the heart. Anchoring of the guidewire, in a stable but atraumatic manner, is particularly important during TAVI procedures, i.e. to ensure accurate and optimum placement of replacement valve and to hold the valve in position during valve implantation and/or during other therapeutic or diagnostic procedures before or after implantation. This also facilitates precise positioning of the sensors in the region of interest for more accurate and reliable measurements of parameters such as blood pressure, transvalvular pressure gradient, and blood flow, both before, during or and after the TAVI procedures.

[126] **Fig. 11B** shows a schematic diagram of a human heart **500** to illustrate placement within the left ventricle **512** of a multisensor guidewire **102**, similar to that shown in **Fig. 5**, for use as both: a) a guidewire during a TAVI procedure and b) for directly measuring a blood pressure gradient across the aortic heart valve **511** before and after the TAVI procedure, wherein a flow sensor **20** is provided for measuring blood flow upstream of the aortic valve **511**. The multisensor guidewire **102** comprises two optical pressure sensors **10a**, **10b**, which are spaced apart by a suitable distance, e.g. at least 20mm to 50mm apart and more preferably about 80mm apart, so that one sensor can be located upstream and one sensor located downstream of the aortic valve **511**. The flow sensor **20** is located further downstream of the aortic valve **511**, in the root of the aorta, e.g. a distance L_{FS} of about 20mm from the nearest pressure sensor **10b**.

[127] For example, a sensor spacing of about 20mm to 50mm would be sufficient to place one sensor upstream and one downstream of a heart valve. However, blood pressure measurements may be affected by significant turbulence in the blood flow through the cardiac cycle. For this reason, a spacing of 80mm between the two sensor
5 locations may be preferred to enable one sensor to be located further into the ventricle and another sensor to be located further upstream of the valve in the aorta, so that both sensors are located in regions of less turbulent flow, i.e. spaced some distance each side of the valve. Based on review of CT scans to assess dimensions of the heart of a number of subjects, an 80mm spacing of two pressure sensors may be preferred. For paediatric
10 use, a closer spacing of the sensors may be preferred.

[128] For comparison, **Figs. 12A, 12B and 12C** show, schematically, three approaches for positioning of the distal end portion **103** of the guidewire **102** through the mitral valve **513**. Correspondingly, **Figs. 13 and 14** show placement through the tricuspid valve **522** and through the pulmonary valve **224**, respectively. Each of these Figures indicates how
15 the three optical pressure sensors **10a, 10b, 10c** would be placed for measurement of a transvalvular pressure gradient.

[129] In practice, it is desirable that a multisensor guidewire provides a plurality of optical pressure sensors, e.g. two or three pressure sensors, and optionally a flow sensor, that are optimally spaced for measurement of transvalvular pressure gradients and flow
20 for any one of the four heart valves. For example, while multisensor guidewires may be individually customized for different TVT procedures, or, for example, smaller sized versions may be provided for paediatric use, it is preferred to have a standard arrangement, e.g., two, three or four sensors, which is suitable for various diagnostic measurements and for use during various TVT procedures.

25 [130] **Transvalvular pressure measurements in interventional cardiology**

[131] By way of example only, the use of a multisensor guidewire for transvalvular pressure measurement will be described with reference to the multisensor guidewire **100** of the first embodiment, and with reference to the aortic valve. For measuring and monitoring the blood pressure gradient across the aortic valve **511**, i.e. the aortic

transvalvular pressure gradient in a human heart **500** (see **Fig. 11A**), a conventional guidewire is first inserted into a peripheral artery, such as the femoral, brachial, or radial artery, using known techniques, and advanced through the ascending aorta **510** into the left ventricle **512**. A catheter is then slid over the guidewire. The operator then advances
5 and positions the catheter into the left ventricle **512**, using a known visualization modality, e.g. X ray imaging along with radio-opaque markers **14** on the distal end, or contrast agent. The operator then replaces the guidewire with the multisensor guidewire **100** in the lumen of the catheter. The operator advances the multisensor guidewire **100** through the catheter and positions the distal end portion **103** of the multisensor guidewire
10 **100** into the left ventricle **512** using visualization devices such as the radio-opaque markers **14** on its distal end **103**. Then, the operator pulls back the catheter over the guidewire. Once the multisensor guidewire **100** is properly positioned, and is coupled to the control unit **151** to activate the optical sensors, the optical pressure sensors **10a**, **10b** and **10c** directly measure the transvalvular pressure gradient of the aortic valve **511**. As
15 illustrated schematically in **Fig. 11A**, two pressure sensors **10a**, **10b** are positioned in the left ventricle **512** and one pressure sensor **10c** is positioned in the aorta **510** just downstream of the aortic valve **511**, to allow simultaneous measurements of pressure at three locations, i.e. both upstream and downstream of the valve. A series of measurements may be taken during several cardiac cycles. Although not illustrated in
20 **Fig. 11A**, a flow sensor **20** may also be provided for simultaneous flow measurements. Measurements results may be displayed graphically, e.g. as a chart on the touch screen display **152** of the system controller **150** (see **Fig. 1**) showing the pressure gradient and flow. The control system may provide for multiple measurements to be averaged over several cycles, and/or may provide for cycle-to-cycle variations to be visualized. Thus,
25 the operator can quickly and easily obtain transvalvular pressure gradient measurements. The valve area may also be computed when blood flow measurements are also available. Measurements may be made, for example, before and after valve replacement or valve repair procedures.

[132] **Figs. 16A, 16B and 16C and Figs. 17A, 17B and 17C** are simplified schematics
30 of the aortic heart valve **511** and left ventricle **512**, illustrating the concept of aortic

transvalvular pressure gradient as measured by the multisensor guidewire **100** using the method of the first embodiment described above, for a healthy heart and for a heart with stenoses **531**, **532** and **533**. In this particular example, the aortic transvalvular pressure gradient is the blood pressure measured by sensors at locations **P1**, **P2** within the left
5 ventricle **512** and **P3** within the aortic root **510**.

[133] The function of the heart is to move de-oxygenated blood from the veins to the lungs and oxygenated blood from the lungs to the body via the arteries. The right side of the heart collects de-oxygenated blood in the right atrium **521** from large peripheral veins, such as, the inferior vena cavae **520**. From the right atrium **521** the blood moves
10 through the tricuspid valve **522** into the right ventricle **523**. The right ventricle **523** pumps the de-oxygenated blood into the lungs via the pulmonary artery **525**. Meanwhile, the left side of the heart collects oxygenated blood from the lungs into the left atrium **514**. From the left atrium **514** the blood moves through the mitral valve **513** into the left ventricle **512**. The left ventricle **512** then pumps the oxygenated blood out to the body
15 through the aorta **510**.

[134] Throughout the cardiac cycle, blood pressure increases and decreases into the aortic root **510** and left ventricle **512**, for example, as illustrated by the pressure curves **630** and **640**, respectively, in **Fig. 15**, which shows curves typical of a healthy heart. The cardiac cycle is coordinated by a series of electrical impulses **610** that are produced by
20 specialized heart cells. The ventricular systole **601** is the period of time when the heart muscles (myocardium) of the right **523** and left ventricles **512** almost simultaneously contract to send the blood through the circulatory system, abruptly decreasing the volume of blood within the ventricles **620**. The ventricular diastole **602** is the period of time when the ventricles **620** relax after contraction in preparation for refilling with circulating
25 blood. During ventricular diastole **602**, the pressure in the left ventricle **640** drops to a minimum value and the volume of blood within the ventricle increases **620**.

[135] The left heart without lesions, illustrated in **Figs. 16A**, **16B** and **16C**, would generate aortic and ventricular pressure curves similar to curves **630** and **640**, respectively, in **Fig. 15**. However, the heart illustrated in **Figs. 17A**, **17B** and **17C** has
30 multiple sites of potential blood flow **530** obstructions **531**, **532** and **533**. In some cases,

the operator of the multisensor guidewire **100** might want to measure the blood pressure at several locations, within the root of the aorta **510** in order to assess a subvalvular aortic stenosis **533** or a supra-avalvular aortic stenosis **531**.

[136] The cardiac hemodynamic data collected from a patient's heart allow a clinician to assess the physiological significance of stenotic lesions. The aortic and ventricular pressure curves from a patient's heart are compared with expected pressure curves. **Fig. 18** illustrates typical differences between the aortic **630** and ventricular **640** pressure curves due to intracardiac obstructions. Some of those variations include the maximal difference **605** and the peak-to-peak difference **606** between curves **630** and **640**. The area **607** between the aortic pressure curve **630** and ventricle pressure curve **640** is also used to assess the physiological significance of stenotic lesions. The difference between the amplitude **603**, **604** of the aortic **630** and ventricle **640** pressure curves is also key information for the clinician.

[137] The medical reference literature relating to cardiac catheterization and hemodynamics provides different possible variations of the aortic **630** and ventricular **640** pressure curves along with the possible causes in order to identify the proper medical diagnosis. For example, cardiac hemodynamic curves, such as shown in **Fig. 18**, along with analysis of the curves, are provided on pages 647 to 653 of the reference book entitled Grossman's cardiac catheterization, angiography, and intervention by Donald S. Baim and William Grossman.

[138] As indicated, when the valve is closed as shown in **Fig. 16A**, the pressures **P1** and **P2** measured by first and second sensors **10a** and **10b** placed in the left ventricle would be equal and lower than the pressure **P3** measured by the third sensor in the aorta during the ventricular diastole **302**. During the ventricular systole **301**, when the aortic valve begins to open, **Fig. 16B**, the pressures **P1**, **P2** and **P3** increase and when the aortic valve is fully open, **Fig. 16C**, **P1**, **P2** and **P3** are similar. The specific form of the pressure traces **P1**, **P2**, **P3** generated by each sensor provides the interventional cardiologist with direct, real-time data to aid in diagnosis and assessment of valve performance before and after TVT.

[139] However, as illustrated schematically in **Figs. 17A, 17B and 17C**, when the heart has subvalvular aortic stenosis **533**, for example, the pressure traces **P1, P2 and P3** will differ. To detect and assess the severity of subvalvular stenosis **533**, the two distal pressure sensors at locations **P1** and **P2** must be located in the left ventricle on each side
5 of stenosis **533** while the proximal pressure sensor **P3** must be located within the root of the aorta **510** at a certain distance from the aortic valve **511**. Therefore, as shown, the distance L_1 (typically about 20 mm) between sensors **10a, 10b** is shorter than the distance L_2 (typically about 50mm or 60mm) between sensors **10b, 10c**, which length is determined by the dimensions of the heart or vascular region to be monitored. As
10 illustrated schematically in **Figs. 17A, 17B and 17C**, when the heart has subvalvular aortic stenosis **533**, for example, the pressure traces **P1, P2 and P3** will differ.

[140] Importantly, the specific positioning of the multiple sensors enables measurements that permit the determination of whether the stenosis is strictly associated with the valve or not, and whether it is associated with a subvalvular stenosis (e.g. sub-aortic hypertrophic stenosis) or supra-aortic stenosis. It also enables measurements that
15 permit the determination of the functional severity of subvalvular stenosis.

[141] **Manufacturability**

[142] During prototyping, a number of challenges have been discovered in attempting to accommodate a plurality of optical sensors and optical fibers within a multisensor
20 guidewires having a required stiffness e.g. 60GPa, and a sufficiently small outside diameter $\leq 1\text{mm}$, and typically 0.89mm or 0.035 inch, for use in TVT. Until smaller diameter optical sensors and optical fibers are developed and characterized, a design of core wire is required to accommodate multiple fibers and sensors without unduly reducing the stiffness of the core wire. In considering manufacturing tolerances for the
25 optical components and for the guidewire coil and core wire, it has also been discovered that there are currently significant manufacturing challenges in providing multisensor guidewires of diameter $\leq 1\text{mm}$ comprising a grooved core wire and multiple optical fibers and optical sensors.

[143] Core wires are conventionally circular in cross-section and manufactured by wire drawing or wire rolling processes, e.g., from suitable metals and alloys, usually medical grade stainless steel, to provide the required mechanical properties, e.g., stiffness, flexibility, tensile strength. Thus, conventionally, small diameter round core wires with
5 sufficient stiffness for guidewires are manufactured by drawing (pulling) a wire through successively smaller dies, or rolling the wire through successively smaller dies.

[144] Manufacturing a sub-millimeter diameter core wire with straight or helical grooves along its length to accommodate individual optical fibers of approximately 100µm diameter, presents challenges for conventional core wire manufacturing facilities.
10 Currently, specialized equipment is needed. Standard manufacturing equipment cannot be used to provide grooved core wires without expensive modifications to the equipment and processes. In practice, the core wire structure of the first embodiment, comprising multiple small grooves spaced circumferentially around the wire, each accommodating an individual optical fiber is therefore complex and/or expensive to manufacture using
15 conventional wire drawing and wire rolling equipment.

[145] Since medical guidewires are intended to be disposable, i.e. for single-use only, an alternative or lower cost manufacturing solution is desirable. However, for medical applications, it will also be appreciated that manufacturing facilities must also be capable of meeting required standards for medical devices. It also desirable to use materials, e.g.,
20 metals and alloys, such as medical grade stainless steel, which already have regulatory approval for medical use and for which extensive manufacturing experience is already available. It is envisaged that alternative materials, such as suitable polymer and composite materials could potentially be used for manufacture of core wires, e.g. if they provide appropriate stiffness and mechanical properties. However, conventional medical
25 grade metals and alloys are preferred.

[146] However, it has been found to be challenging to manufacture grooved stainless steel core wires of the required size and tolerances by known wire drawing processes, particularly a plurality of small grooves to accommodate individual fibers. Also, using existing wire drawing equipment used for medical guidewires, it is difficult to control
30 rotation of grooves along the length of the wire, e.g. to form helical grooves of a pre-

defined pitch. While it is expected that manufacturing challenges may be overcome in the near future, a core wire with a cross-sectional profile providing a simpler channel surface e.g. comprising a single larger groove accommodating multiple fibers, which can be manufactured by conventional grinding, wire-drawing or wire-rolling provides an alternative, more cost effective solution in the near term.

[147] For example, the multisensor guidewire of the second embodiment having a core wire that has a cross-sectional profile which is shaped with a contoured channel surface as illustrated in **Fig. 8**, i.e. a scalloped channel surface which may be formed by wire-rolling or wire drawing processes. The guidewire has an outside diameter of 0.89mm (0.035 inch) and comprising three Fabry-Pérot optical sensors, each coupled to individual optical fibers having a diameter D_F of $100 \pm 0.4 \mu\text{m}$ (.0039" \pm .0002"), a core wire formed having a cross-section as shown in **Fig. 8**, formed by wire rolling, may have the following dimensions: $R_1 = .0145" \pm .00037"$; $R_2 = .009" \pm .0015"$; $R_F = .003" \pm .0015"$; $R_{\text{ext}} = .005" \pm .0015"$; and $w = .010"$. Thus, for example, to allow for these manufacturing tolerances, a clearance C_L of 0.001" (1mil) is required.

[148] In other variants or modifications of these embodiments of a core wire formed by conventional wire rolling or wire drawing, other cross-sectional profiles may be provided with one or more grooves, each groove accommodating a plurality of optical fibers. For a single groove, the core wire has, for example, a generally D-shaped cross-sectional profile or a lune-shaped profile. Other more complex profiles with multiple contoured grooves are also contemplated, such as those shown in **Figs. 10A, 10B and 10C**. Provided that the core wire structures of these alternative embodiments are dimensioned to be formed by known wire drawing or wire rolling processes, they offer some advantages with respect to manufacturability and cost of manufacturing relative to structures with a plurality of smaller grooves, where each groove accommodates a single fiber and sensor.

[149] Also, it is believed that formation of a channel surface by wire rolling, rather than wire drawing, may be advantageous for some applications. For example, during rolling of a stainless steel wire, i.e. by compression of the core wire within a die, this process is expected to somewhat harden or stiffen the core wire surface region defining the channel

surface. Thus, while a channel surface is created to form a space or channel between the core wire and outer coil of the guidewire to accommodate a plurality of optical fibers, a higher overall stiffness of the wire may be obtained for a wire of a particular diameter D_{core} .

5 [150] **Contact force sensor**

[151] Beneficially, for use in TVT, the multisensor guidewire **100** is also capable of measuring a contact force of the guidewire against the wall of the heart, e.g. the wall of a diseased left ventricle. Thus, a guidewire according to another embodiment comprises an integral fiber-optic contact force sensor **60** as illustrated schematically in **Figs. 22, 23, 24,**
10 **25A** and **25B** e.g. an optical strain gauge type of sensor, located at a suitable position in or near the distal end portion **103**. For example, as illustrated in **Figs. 22** and **23**, the optical contact force sensor **60** comprises a Fabry-Pérot MOMS sensor **61** which is located in the distal end portion **103** and is coupled by a respective optical fiber **11** to an input output optical connector, e.g. to the micro-optical connector **140** as previously
15 described. The cavity **62** and diaphragm **63** of the Fabry-Pérot MOMS sensor **61** is also coupled to a length L_{CS} of a second optical fiber **64** which extends from the sensor **61** along the length L_{CS} of the distal end of the guidewire, towards the flexible tip **120**. As illustrated in **Figs. 25A** and **25B**, the second optical fiber **64** sits in a helical groove **32** in the core wire which is enlarged to form a recess **34** at A-A to accommodate the sensor
20 **61**. As indicated in **Fig. 23**, the sensor **61** and the end of fiber **64** are fixed to the core wire at points **66**. This arrangement allows for the sensor **61** to detect and measure a contact force applied along a length L_{CS} of the guidewire when it contacts the internal heart walls **215** of the heart as indicated schematically in **Fig. 24**. Such a contact force sensor **60** provides information and feedback to the cardiologist regarding the force **F** being applied, e.g. when a detected contact force approaches or exceeds a threshold F_t
25 that may cause tissue damage, or potentially even cause fatal injuries during TVT, an alert may be provided to the operator.

[152] Thus for example the guidewire **100** may comprises three optical pressure sensors **10a, 10b, 10c** as described above with reference to **Figs. 2** and **3**, optionally a flow
30 sensor **20** located in the distal end portion, and a contact force sensor **60** located in a

region between the distal end portion **103** containing the optical pressure sensors and the flexible distal tip **120**, to sense a contact force applied near the end of the guidewire, along the length L_{CS} indicated by the dotted line in **Fig. 26**.

[153] **Flexible preformed three-dimensional curved tip**

5 [154] To assist in atraumatic insertion and anchoring of the guidewire **100** within the ventricle during TVT, it is desirable to use a flexible preformed tip such as a J tip or other curved tip. **Figs. 27A** and **27B** show two views of a pre-formed flexible tip **400-1** having a three-dimensional form, specifically in this embodiment, a pre-formed helical tip, of coil diameter D_T , e.g. 5cm, which resembles part of a telephone cord or a pigtail. A tip
10 **400-2** of another embodiment, as illustrated in **Figs. 29A** and **29B**, comprises a pre-formed helix that is tapered to resemble the form of a snail shell. **Figs. 28** and **30**, respectively, represent schematically the placement of these pre-formed helical tips **400-1** and **400-2** in left ventricle **512** for TVT or for diagnostic measurements using the optical pressure sensors **100**. This three-dimensional pre-formed structure is proposed for
15 improved support of the guidewire in each of the X, Y and Z directions during TVT procedures. Such a structure can assist in providing support for the guidewire in a safer manner.

[155] **Further embodiments**

[156] It will be appreciated that in alternative embodiments or variants of the present
20 embodiments, one or more features disclosed herein may be combined in different combinations or with one or more features disclosed herein and in the related patent applications referenced herein.

[157] A core wire having multiple straight or helical grooves along its length accommodates a plurality of optical sensors and optical fibers within a required diameter
25 without significantly reducing the stiffness of the core wire or its torque characteristics. For lower cost manufacturing, the core wire may have a simpler channel surface, such as, one or more grooves formed by grinding, or a single groove with a contoured or scalloped surface structure formed by wire-rolling.

[158] Additionally, for valve replacement, since the guidewire must be firmly anchored within the ventricle for accurate measurements and for positioning of a replacement valve, an optional preformed curved tip, such as a pre-formed “snail” tip as assists in anchoring the guidewire in the ventricle during TAVI.

5 [159] Furthermore, an optional contact force sensor near the tip provides important feedback to the interventional cardiologist relating to the force being applied or transferred internally to the heart wall. Feedback to the cardiologist to indicate when a contact force exceeds a threshold level, together with a specially shaped pre-formed flexible tip, assists in reducing trauma to the tissues of the heart, and in particular reduces
10 risk of perforation the ventricular wall. Thus, the interventional cardiologist is offered a guidewire which simplifies both diagnostic measurements and TAVI procedures, including heart valve implantation, and which could potentially assist with reducing mortality and avoiding trauma or perforations.

INDUSTRIAL APPLICABILITY

15 [160] Currently, patient mortality rate after TAVI is significant, with some studies reporting mortality in a range of 10%-15%. As shown by a growing number of studies, interventional cardiologists need accurate data, i.e. measurements of cardiovascular parameters to assess the functional performance of a patient’s heart valves before and after TAVI, to obtain a better understanding of the issues and to find solutions to reduce
20 mortality and reduce the need for re-intervention after TAVI. Methods currently available to diagnose cardiac valve disease do not allow interventional cardiologists to resolve this major issue.

[161] Systems and apparatus according to embodiments of the invention comprise multisensor support guidewires for use in TAVI, such as TAVI. These “Smart
25 GuidewiresTM” not only have the required mechanical characteristics to act as support guidewires for TAVI, they comprise sensors for making direct (*in-situ*) measurements of important parameters, including measurement of a transvalvular blood pressure gradient and optionally blood flow, for evaluation of performance of the heart and the heart valves immediately before and after TAVI. A single-use disposable guidewire integrating

multiple optical sensors allows for quickly providing real-time accurate quantitative data related to functional performance of heart valves right before and after TVT.

[162] Although embodiments of the invention have been described and illustrated in detail, it is to be clearly understood that the same is by way of illustration and example
5 only and not to be taken by way of limitation, the scope of the present invention being limited only by the appended claims.

CLAIMS

1. A multisensor guidewire for diagnostic measurements in interventional cardiology comprising:

5 an outer flexible coil wire (coil) having a length extending between a proximal end and a distal end, an outside diameter of ≤ 1 mm, and a core wire extending within the coil from the proximal end to the distal end, the distal end comprising a flexible distal tip;

10 a sensor arrangement comprising a plurality of optical sensors and a plurality of optical fibers; a sensor end of each optical fiber being attached and optically coupled to an individual one of the plurality of optical sensors; the plurality of optical fibers extending within the coil from the proximal end to sensor locations within a distal end portion of the coil, proximal to the distal tip;

15 the core wire having a cross-sectional profile defining a channel means along a length of the core wire, the channel means comprising part of a surface of the core wire providing at least one channel, between a channel surface of the core wire and the coil, accommodating therein the plurality of optical sensors and their respective optical fibers;

a proximal end of each of the plurality of optical fibers being coupled to an optical input/output connector at the proximal end of the guidewire for connection to an optical control system; and

20 the plurality of optical sensors of the sensor arrangement including two or more optical pressure sensors at respective sensor locations spaced apart along a length of the distal end portion of the core wire.

25 2. The multisensor guidewire of claim 1, wherein the channel means comprises a plurality of grooves each defined by a channel surface extending along the length of the core wire, each groove accommodating an individual optical fiber and its respective optical sensor.

3. The multisensor guidewire of claim 1, wherein the channel means comprises a plurality of helical grooves, each defined by a channel surface extending along the length

of the core wire, each groove accommodating an individual optical fiber coupled and its respective optical sensor.

4. The multisensor guidewire of claim 3, wherein the helical grooves have a pitch of at least 25mm (1 inch).
- 5 5. The multisensor guidewire of claim 1, wherein the channel means comprises a single groove defined by a channel surface extending along the length of the core wire, the groove accommodating the plurality of optical sensors and respective optical fibers.
6. The multisensor guidewire of claim 1, wherein the channel surface defines a one or more channels along the length of a core wire and each channel surface is contoured to
10 fit a plurality of optical fibers side by side within a diameter D_{core} of the core wire.
7. The multisensor guidewire of claim 1, wherein the core wire has a cross-sectional profile which is substantially a major segment of a circular shape, and the channel means comprises a channel surface defined by a chord of the circular shape.
8. The multisensor guidewire of claim 1, wherein the core wire has a cross-sectional
15 profile which is one of: generally D-shaped; generally lune-shaped; kidney shaped, a major segment of a circle, and a combination thereof.
9. The multisensor guidewire of claim 8, wherein the channel surface comprises one of:
flat; convex; concave; furrowed; contoured with concave and convex portions; scalloped;
20 and a combination thereof;
the channel surface thereby defining the channel between the core wire and the coil and accommodating therein the plurality of optical fibers and respective optical sensors.
10. The multisensor guidewire of claim 1, wherein the channel surface is contoured to
position a plurality of optical fibers side-by-side in each channel, within a diameter D_{core}
25 of the core wire.

11. The multisensor guidewire of claim 1, wherein the channel surface comprises a plurality of furrows with a ridge therebetween for accommodating a plurality of optical fibers side-by-side within a diameter D_{core} of the core wire.
12. The multisensor guidewire of claim 1, wherein the core wire has a generally
5 circular cross section having a major portion (circle sector) of outer radius R_1 and a minor portion (circle sector) of outer radius R_2 , where $R_2 < R_1$ to define a channel surface along a length of the core wire for accommodating a plurality of optical fibers, wherein $R_1 - R_2$ is greater than or equal to the diameter of the fiber to be accommodated, and wherein the arc of the minor section accommodates the plurality of fibers side-by-side
10 circumferentially.
13. The multisensor guidewire of claim 12, wherein all surfaces of the core wire are radiused to no less than a minimum radius R_{min} for formation of the channel surface by known wire-rolling or wire-drawing processes.
14. The multisensor guidewire of any one of claims 1 to 13, wherein the optical fibers
15 are adhesively bonded to the channel surface of the core wire.
15. The multisensor guidewire of any one of claims 1 to 14, wherein the coil has an outside diameter of $\leq 0.89\text{mm}$ or $\leq 0.035\text{inch}$.
16. The multisensor guidewire of any one of claims 1 to 15, wherein the material and diameter D_{core} of the core wire in at least the distal end portion provides a flexural
20 modulus of 60GPa +/- 10%.
17. The multisensor guidewire of any one of claims 1 to 15, wherein the material and diameter D_{core} of the core wire in at least the distal end portion provides a flexural modulus of 60GPa or more.
18. The multisensor guidewire of any one of claims 1 to 15, wherein the material and
25 diameter D_{core} of the core wire in at least the distal end portion provides the guidewire with predetermined stiffness characteristics defined by an indicator or descriptor, said indicator being one of stiff, super-stiff and ultra-stiff.

19. The multisensor guidewire of any one of claims 1 to 18, wherein the plurality of optical fibers and respective optical sensors sit within the channel means of the core wire without protruding beyond the diameter D_{core} of the core wire.
20. The multisensor guidewire of any one of claims 1 to 19, wherein the optical
5 sensors and optical fibers sit within the channel means without protruding beyond the diameter D_{core} of the core wire, and wherein, at sensor positions in the distal end portion, the grooves are enlarged to accommodate the optical sensors.
21. The multisensor guidewire of any one of claims 1 to 20, comprising first, second and third optical pressure sensors, the first and second optical pressure sensors being
10 located at more distal sensor positions spaced apart by a first distance L_1 and the third optical pressure sensors being at a more proximal sensor position spaced from the second optical sensor a second distance L_2 , where $L_2 > L_1$.
22. The multisensor guidewire of claim 21, wherein L_1 is about 20mm and L_2 is about 60mm.
- 15 23. The multisensor guidewire of any one of claims 1 to 22, further comprising a flow sensor.
24. The multisensor guidewire of any one of claims 1 to 22, wherein the plurality of optical sensors further comprises an optical flow sensor.
25. The multisensor guidewire of any one of claims 1 to 22, wherein the plurality of
20 optical sensors further comprises an optical flow sensor located proximally of the optical pressure sensors.
26. The multisensor guidewire of any one of claims 1 to 22, wherein the plurality of optical sensors further comprises an optical flow sensor located proximally of the optical pressure sensors by a distance L_{FS} of about 20mm.
- 25 27. The multisensor guidewire of any one of claims 1 to 26, comprising three optical sensors and respective optical fibers, wherein the core wire provides a guidewire having flexural modulus of 60GPa or more.

28. The multisensor guidewire of any one of claims 1 to 26, comprising four optical sensors and respective optical fibers, wherein the core wire provides a guidewire having flexural modulus of 60GPa or more.
29. The multisensor guidewire of any one of claims 1 to 28, wherein apertures are provided in the coil adjacent each optical pressure sensor for fluid contact therewith.
30. The multisensor guidewire of any one of claims 1 to 29, wherein radiopaque markers are provided adjacent each optical pressure sensor.
31. The multisensor guidewire of any one of claims 1 to 30, wherein the guidewire comprises a separable micro-optical coupler coupling proximal and distal parts of the guidewire to enable on/over-the-guidewire delivery of components.
32. The multisensor guidewire of any one of claims 1 to 31, further comprising a contact force sensor.
33. The multisensor guidewire of any one of claims 1 to 31, wherein the plurality of optical sensors further comprises an optical contact force sensor.
34. The multisensor guidewire of any one of claims 1 to 33, wherein the optical input/output connector at the proximal end has an outside diameter no greater than the outside diameter of the coil.
35. The multisensor guidewire of any one of claims 1 to 34, wherein the optical input/output connector has an outside diameter of $\leq 0.89\text{mm}$.
36. The multisensor guidewire of any one of claims 1 to 35, wherein the flexible distal tip comprises a pre-formed curved tip.
37. The multisensor guidewire of claim 36, having a pre-formed tip of a three dimensional curved structure.
38. The multisensor guidewire of claim 37, wherein the three dimensional curved structure is a helical structure.

39. The multisensor guidewire of claim 38, wherein the flexible distal tip comprises a pre-formed curved tip having a helical structure with a tapered shape resembling a snail shell.
40. The multisensor guidewire of any one of claims 1 to 39, comprising separable
5 distal and proximal parts connected by an optical coupler.
41. The multisensor guidewire of claim 40, wherein the distal part comprises a male connector of the optical coupler and the proximal part comprises a female connector of the optical coupler, the male connector having an outside diameter no greater than the outside diameter of the coil of the guidewire.
- 10 42. The multisensor guidewire of 41, wherein a proximal end of the core wire comprises a tapered portion that extends to form a core of the male connector and the plurality of optical fibers and extend around the tapered portion, around the core, and through a surrounding body of the male connector.
43. The multisensor guidewire of claim 42, wherein the optical coupler further
15 comprises alignment means and/or fastening means.
44. A sensor guidewire comprising at least one optical sensor, wherein the guidewire comprises a separable micro-optical coupler coupling proximal and distal parts of the guidewire to enable on/over the guidewire delivery of components.
45. A multisensor support guidewire apparatus for use in TVT, comprising separable
20 distal and proximal parts connected by an optical coupler, wherein
the distal part comprises a multisensor support guidewire;
the proximal part comprises a flexible tubular member containing a plurality of optical fibers, and having at its proximal end an optical connector for coupling to the optical controller and having at its distal end the female connector of the optical coupler;
- 25 the optical input/output connector at the proximal end of the distal part forming the male part of the optical coupler and having an outside diameter no greater than that of the coil of the guidewire; and

the optical coupler providing coupling of the plurality of individual optical fibers of the distal part to respective ones of the plurality of individual optical fibers of the proximal part.

46. A sensor guidewire comprising a sensor located near a distal end of the guidewire
5 for monitoring a contact force applied to a length of a distal end portion.

47. A sensor guidewire comprising an optical sensor located near a distal end of the guidewire for monitoring a contact force applied to a length of a distal end portion.

48. A sensor support guidewire for use in TVT, comprising:

a flexible coil wire (coil) having an outside diameter of $\leq 0.89\text{mm}$ (0.035inch) and a core
10 wire extending within the coil from a proximal end to a distal end, the distal end comprising a flexible distal tip;

an optical contact force sensor comprising a Fabry-Pérot MOMS optical sensor located within a distal end portion of the guidewire;

the Fabry-Pérot MOMS optical sensor being coupled by a first optical fiber to an optical
15 input/output connector at a proximal end of the guidewire for connection to a control system, and a diaphragm of the Fabry-Pérot MOMS optical sensor being coupled to a second optical fiber which extends through a length of the distal end portion for monitoring a contact force applied to said length of the distal end portion;

the core wire having a groove defined in its surface along a length of the core wire, the
20 groove accommodating therein the Fabry-Pérot MOMS optical sensor and the first and second optical fibers.

49. A system, comprising a sensor support guidewire as defined in claim 48, and further comprising a controller for monitoring a contact force applied to said length of the distal end portion and providing feedback to the user indicative of the contact force.

25 50. A system according to claim 49, wherein the controller provides an alert when the contact force exceeds a predetermined threshold value.

51. A support guidewire for use in TVT having a flexible distal tip comprising a pre-formed three dimensional curved structure.
52. A support guidewire according to claim 51, wherein the pre-formed three dimensional curved structure comprises a helix.
- 5 53. A support guidewire according to claim 52, wherein the pre-formed three dimensional curved structure comprises a tapered helix resembling a snail shell.
54. A core wire for a sensor guidewire comprising an outer flexible coil wire of outside diameter of 1mm or less, the core wire having a diameter D_{core} to fit within the outer flexible coil wire, and the core wire having a cross-section profile defining a
10 channel means along a length of the core wire, the channel means comprising part of a surface of the core wire comprising a channel surface recessed within the diameter D_{core} and extending along the length of the core wire for accommodating or more optical fibers within the diameter D_{core} of the core wire.
55. The core wire of claim 54, wherein the channel surface comprises a plurality of
15 grooves defined along the length of the guidewire, wherein each groove accommodates an individual optical fiber within the diameter D_{core} of the core wire.
56. The core wire of claim 55, wherein the plurality of grooves comprise helical grooves.
57. The core wire of claim 54, wherein the channel surface is contoured to a
20 accommodate plurality of optical fibers within the diameter D_{core} of the core wire.
58. A core wire according to claim 57, wherein the channel surface has a plurality of furrows with a ridge therebetween for accommodating a plurality of optical fibers within the diameter D_{core} of the core wire.
59. A core wire according to claim 57, wherein the core wire is of generally circular
25 cross section having a major portion (circle sector) of outer radius R_1 and a minor portion (circle sector) of outer radius R_2 , where $R_2 < R_1$ to define a channel surface along a length of the core wire for accommodating a plurality of optical fibers, wherein $R_1 - R_2 \geq$ the

diameter of the fiber to be accommodated, and wherein the arc of the minor section accommodates the plurality of fibers side by side circumferentially, and all surfaces of the core wire are radiused to no less than R_{\min} which meets a minimum for formation of the channel surface by known wire rolling processes.

- 5 60. A core wire according to claim 54, having a cross-sectional profile defined by a major segment of a circle.
61. A core wire according to claim 54, having a substantially D- shaped cross-sectional profile.
62. A core wire according to any one of claims 54 to 61, wherein the channel surface
10 is defined by a cross-sectional profile of the core wire along its length defined by wire-drawing.
63. A core wire according to any one of claims 54 to 61, wherein the channel surface comprises a groove along the length of the core wire formed by grinding.
64. A core wire according to any one of claims 54 to 61, wherein the channel surface
15 comprises a contoured structure formed by wire-rolling or wire-drawing.
65. A core wire according to any one of claims 54 to 61, accommodating a plurality of three optical fibers, wherein the channel surface comprises two furrows and a ridge therebetween, positioning centres of each fiber at a similar radial distance from the centre of the core wire, and within the outer diameter of the core wire.
- 20 66. A core wire according to any one of claims 54 to 61, wherein any radiused surfaces of the channel surface each have a radius of at least a minimum radius for formation by one of wire-rolling and wire-drawing, and a combination thereof.
67. A core wire according to any one of claims 54 to 66, fabricated from a medical grade stainless steel alloy.
- 25 68. A core wire assembly, comprising a core wire as defined in claim 54, and further comprising a plurality of optical fibers and optical sensors, each optical fiber being coupled to at a distal end to a respective optical sensor, the plurality of optical fibers

being positioned within one or more recessed surface channels, each defined by a respective channel surface along the length of the core wire to position the optical fibers within the diameter D_{core} of the core wire.

69. The core wire assembly of claim 68, wherein the one or more recessed surface
5 channels are enlarged at sensor locations.

70. The core wire assembly of claim 68 or 69, wherein the optical fibers are adhesively bonded to the respective channel surface of the core wire.

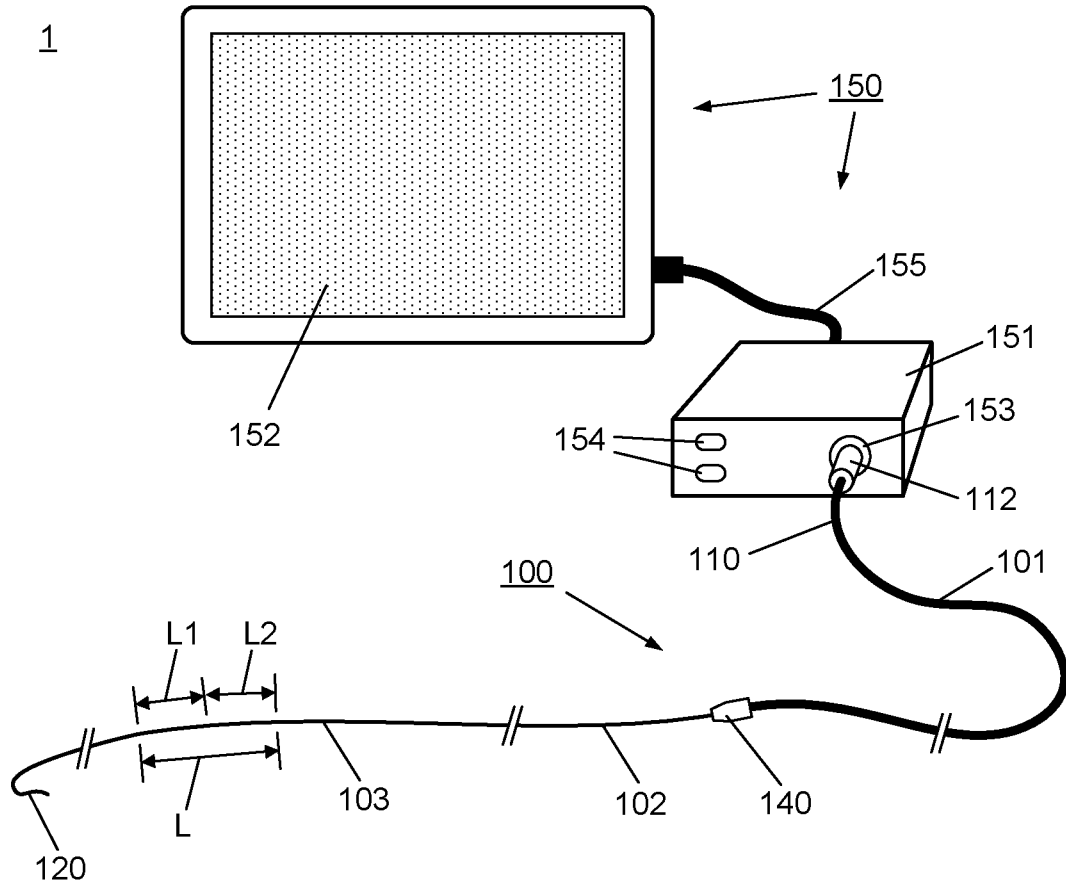

FIG. 1

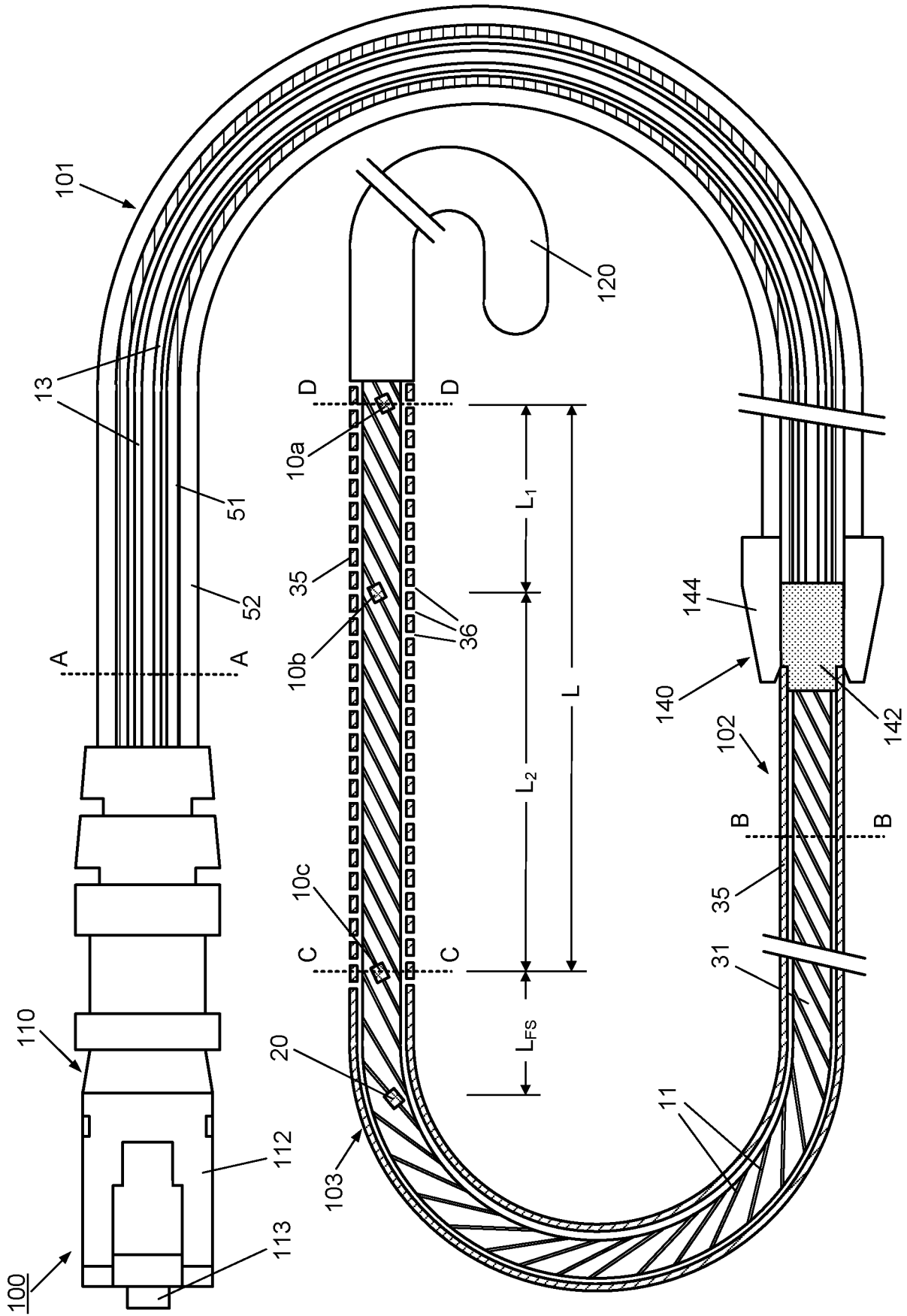

FIG. 2

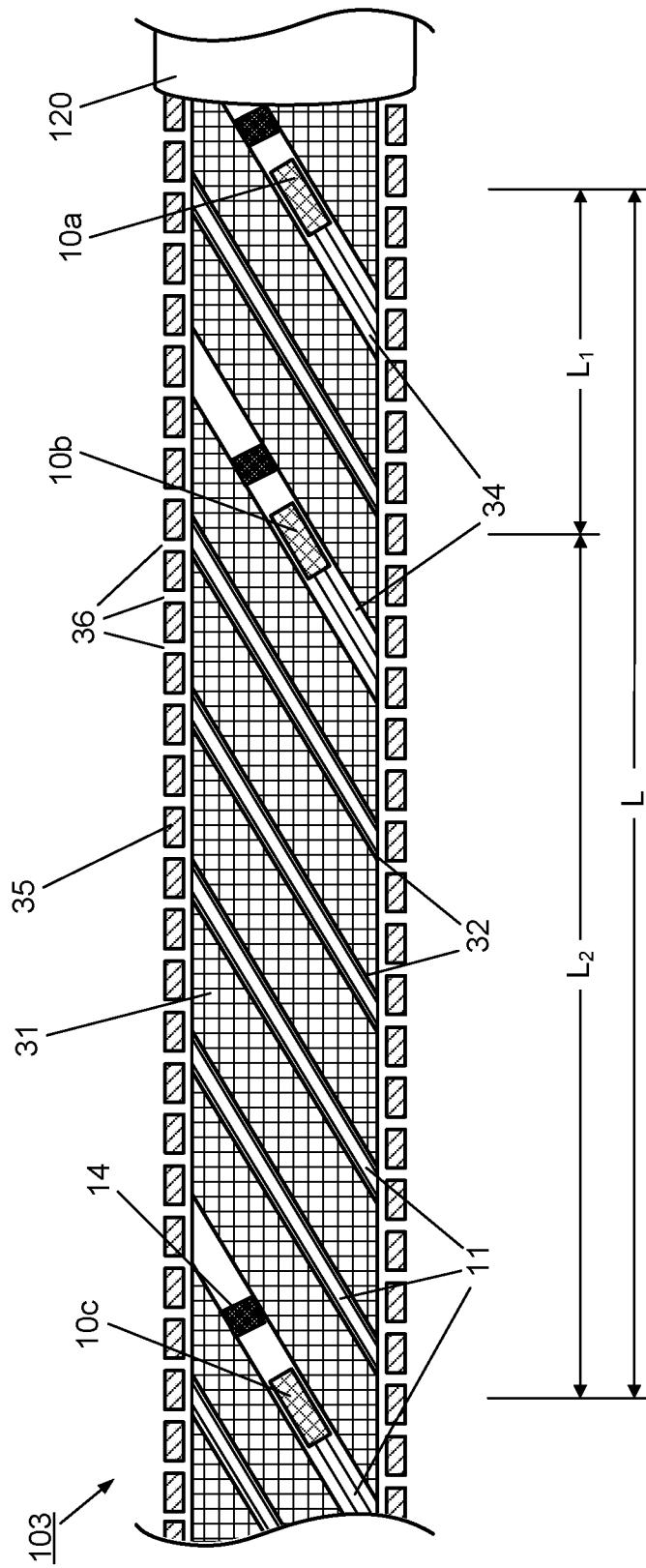

FIG. 3

A-A CUT-THROUGH VIEW OF FIG. 2

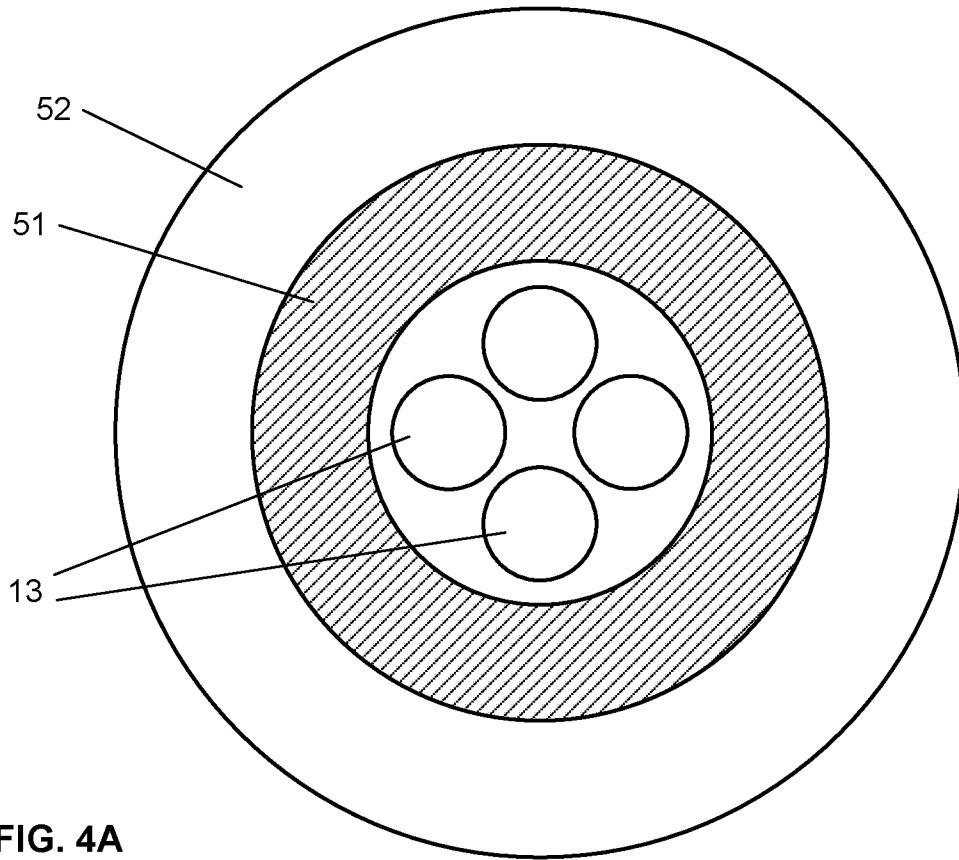

FIG. 4A

B-B CUT-THROUGH VIEW OF FIG. 2

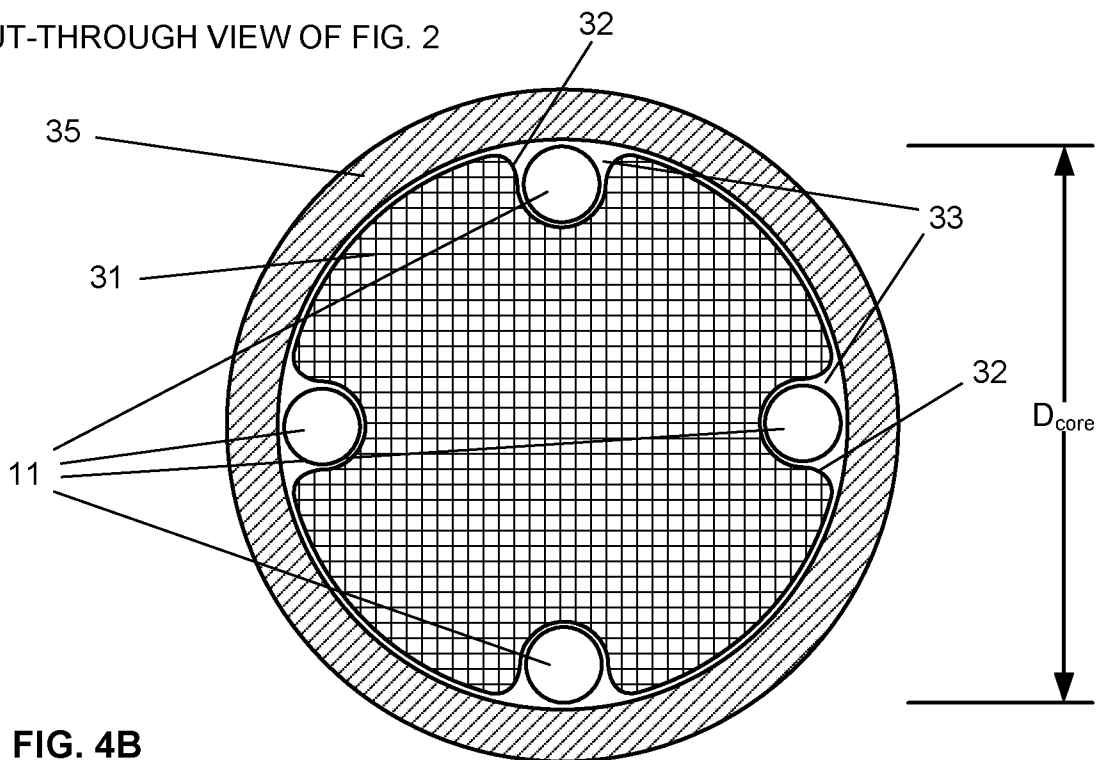

FIG. 4B

C-C CUT-THROUGH VIEW OF FIG. 2

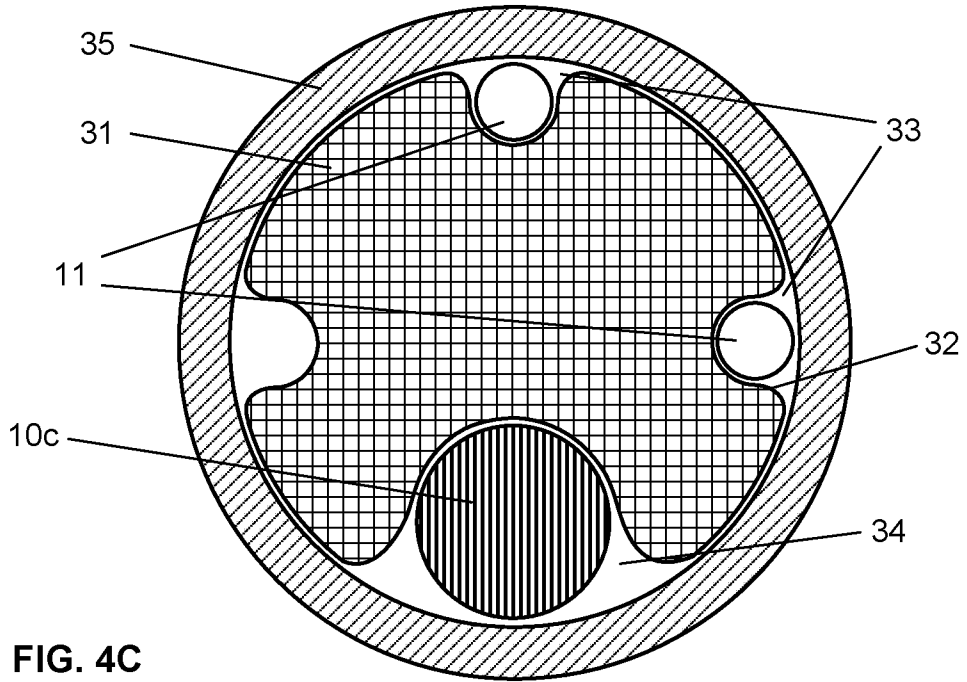

FIG. 4C

D-D CUT-THROUGH VIEW OF FIG. 2

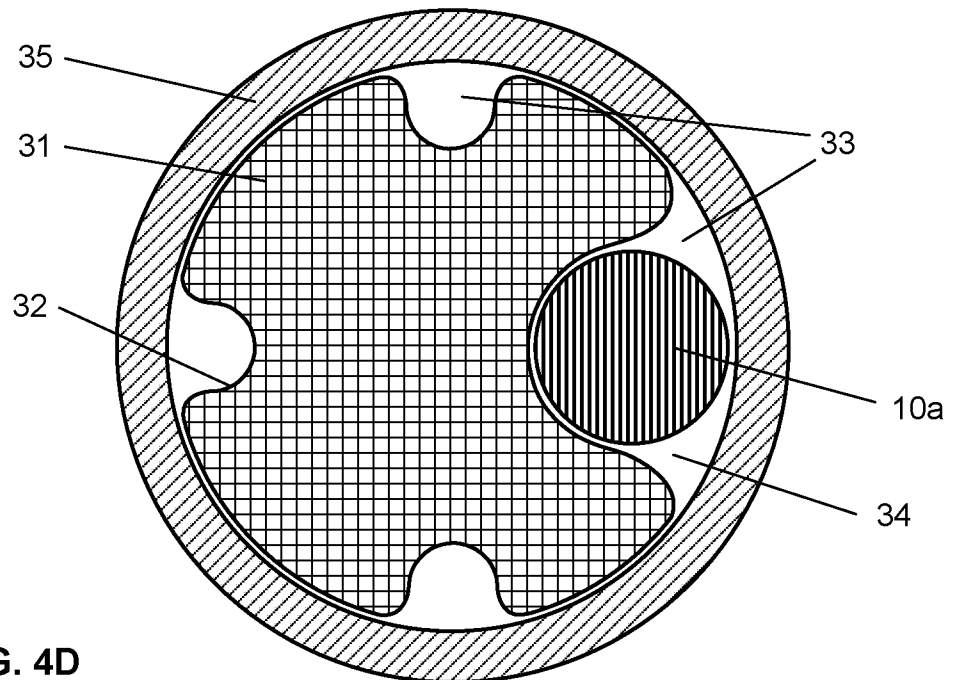

FIG. 4D

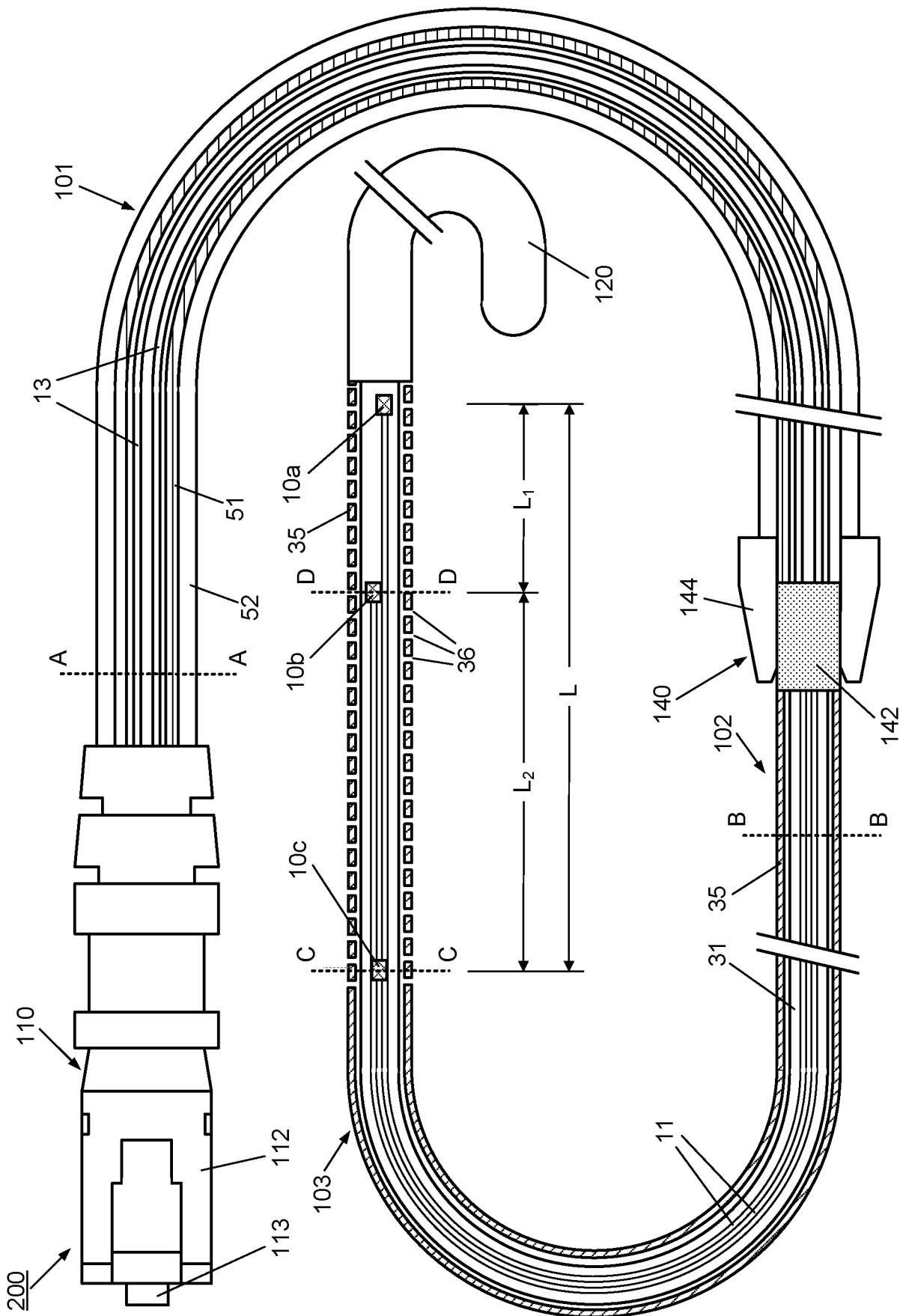

FIG. 5A

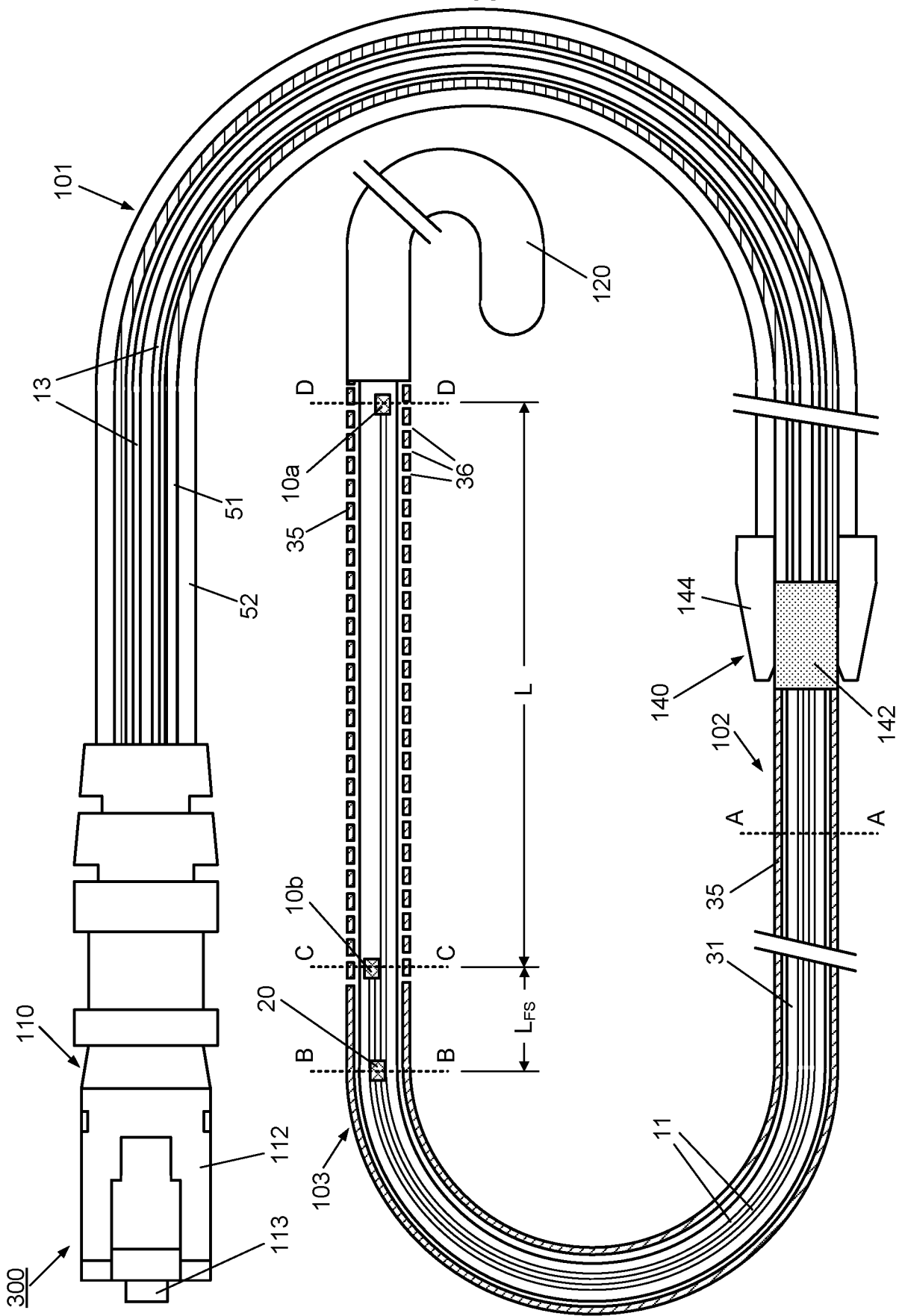

FIG. 5B

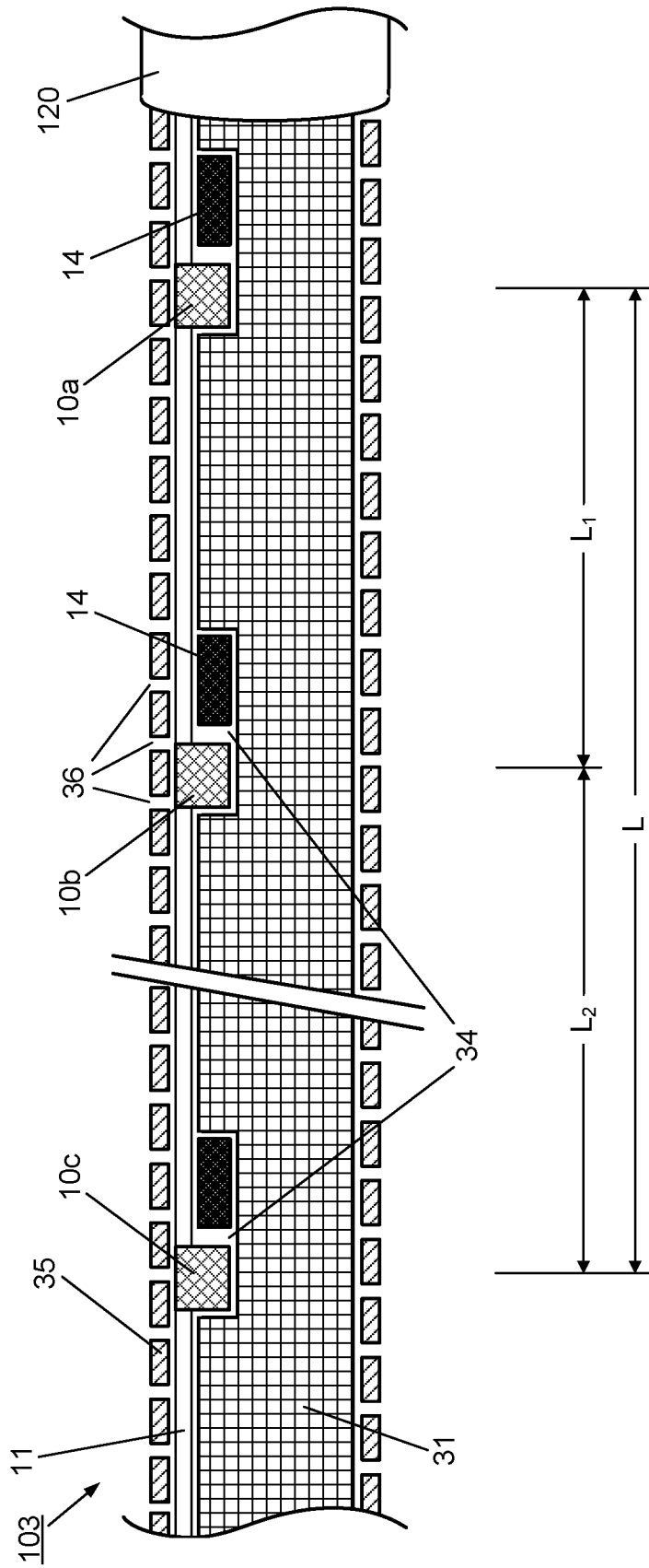

FIG. 6

A-A CUT-THROUGH VIEW OF FIG. 5A

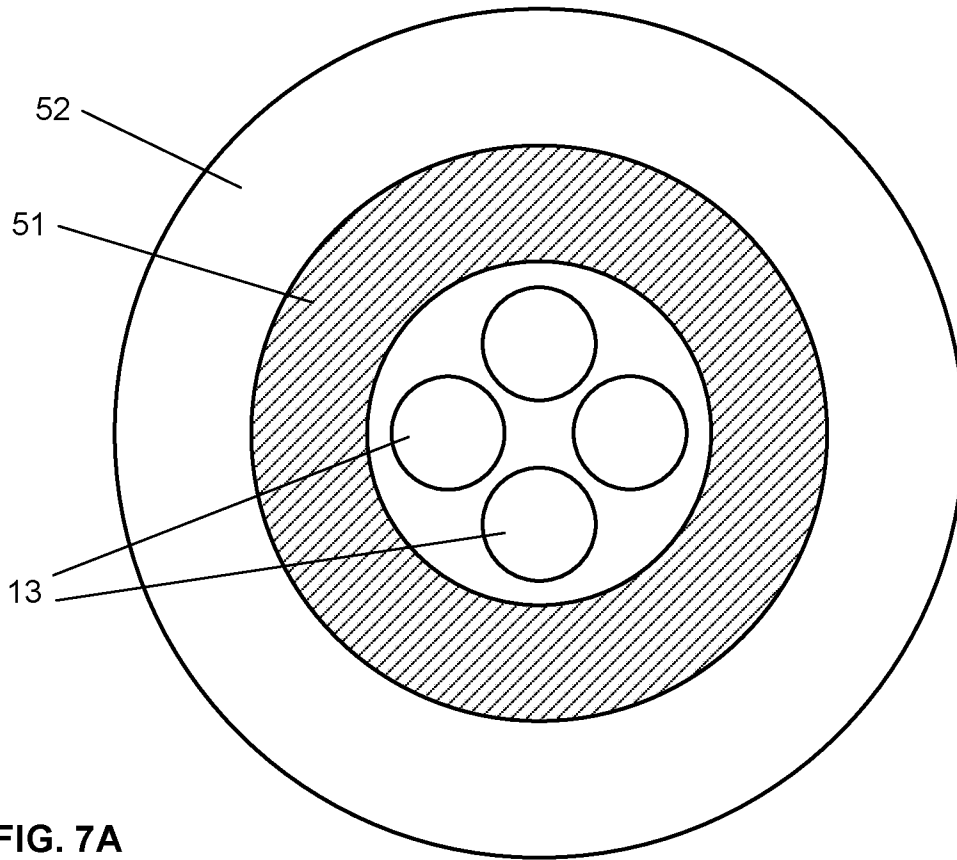

FIG. 7A

B-B CUT-THROUGH VIEW OF FIG. 5A

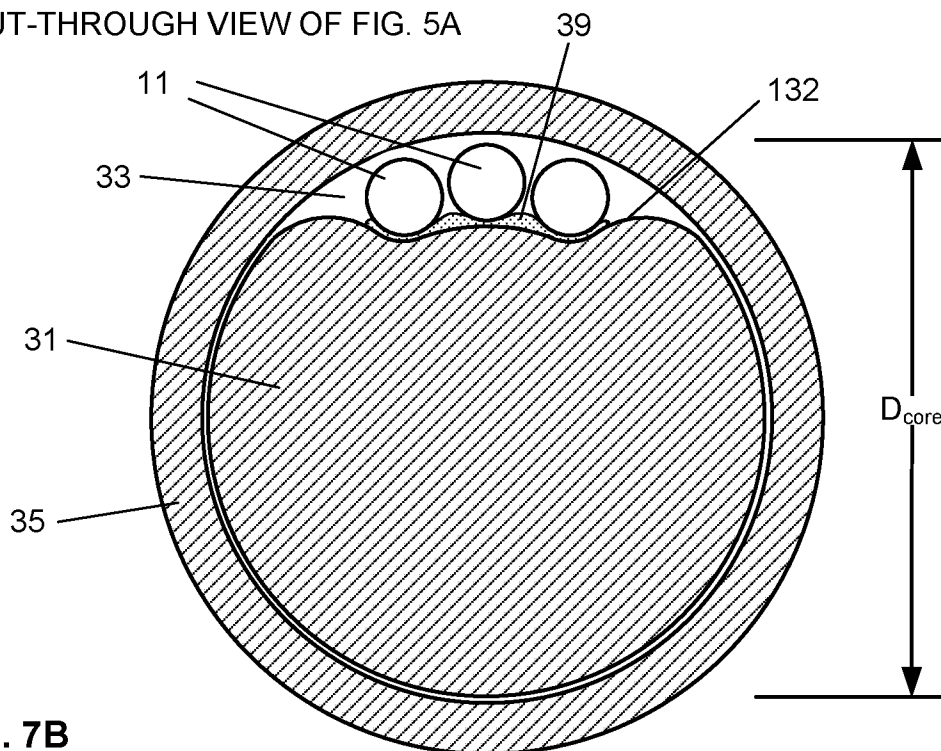

FIG. 7B

10/38

C-C CUT-THROUGH VIEW OF FIG. 5A

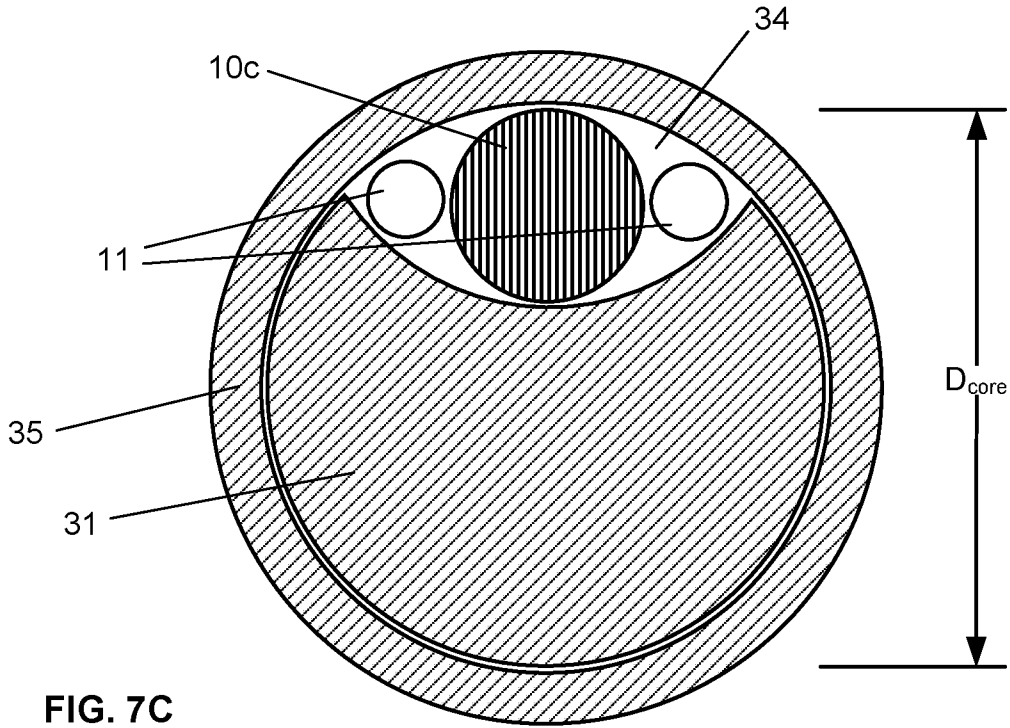

FIG. 7C

D-D CUT-THROUGH VIEW OF FIG. 5A

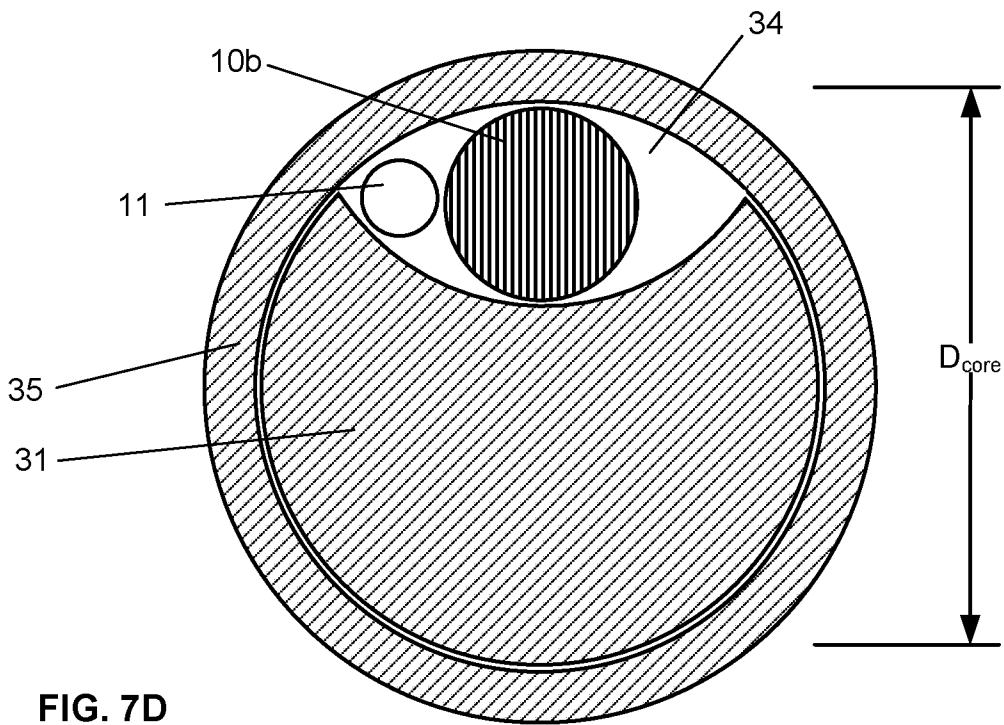

FIG. 7D

B-B CUT-THROUGH VIEW OF FIG. 5A

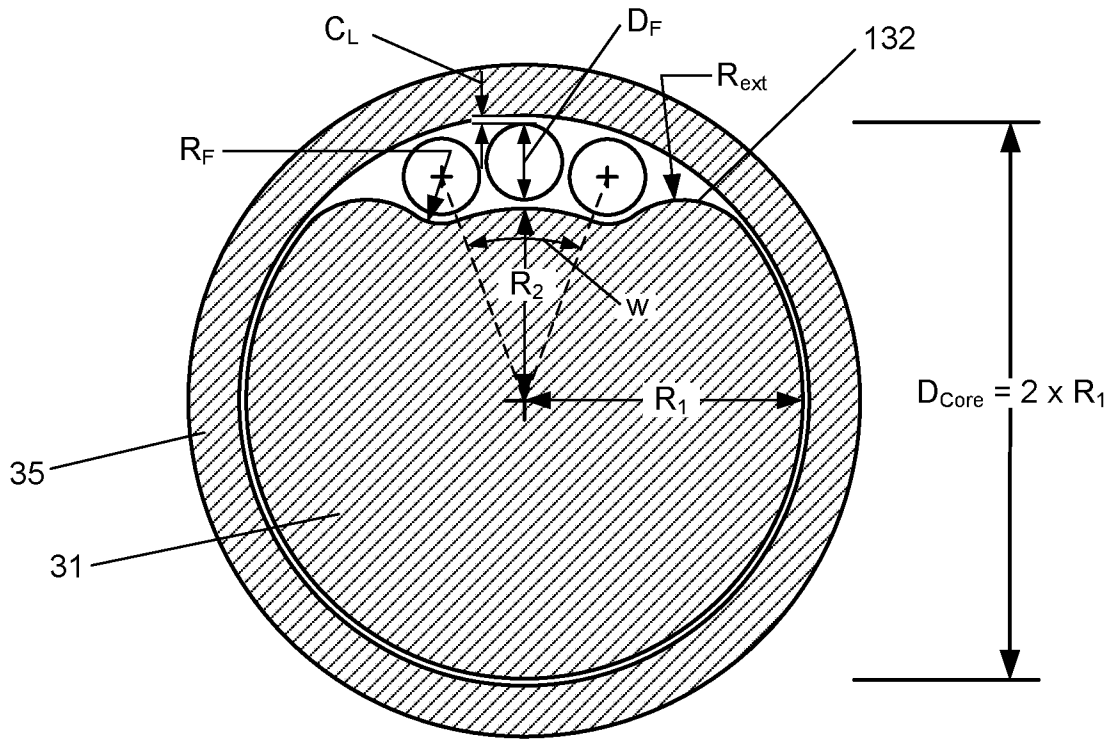

FIG. 8

A-A CUT-THROUGH VIEW OF FIG. 5B

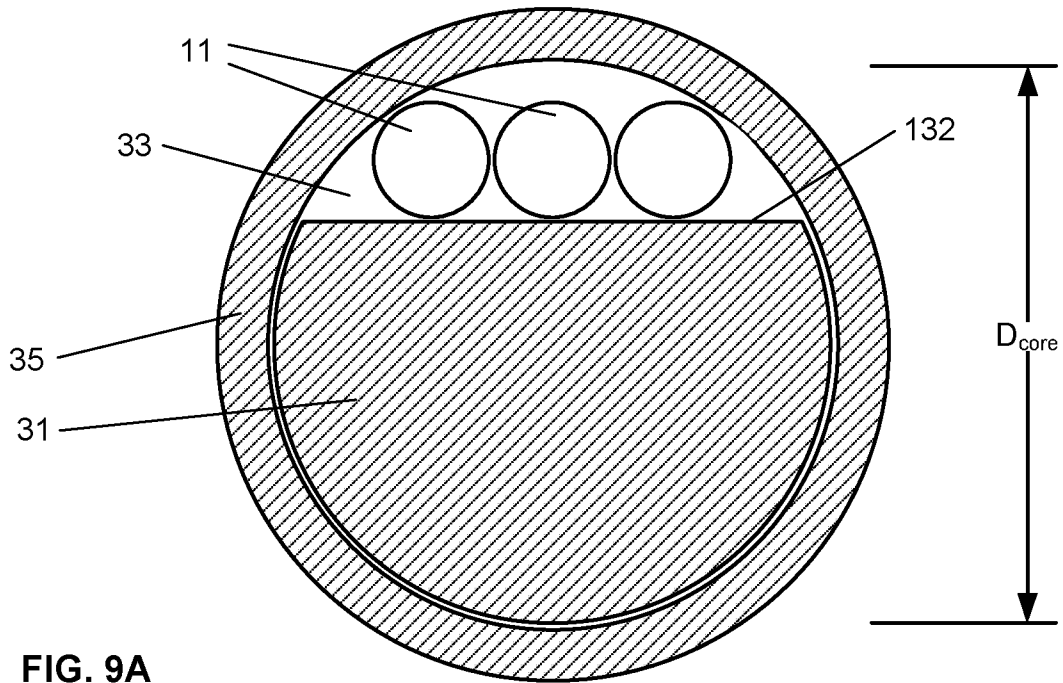

FIG. 9A

B-B CUT-THROUGH VIEW OF FIG. 5B

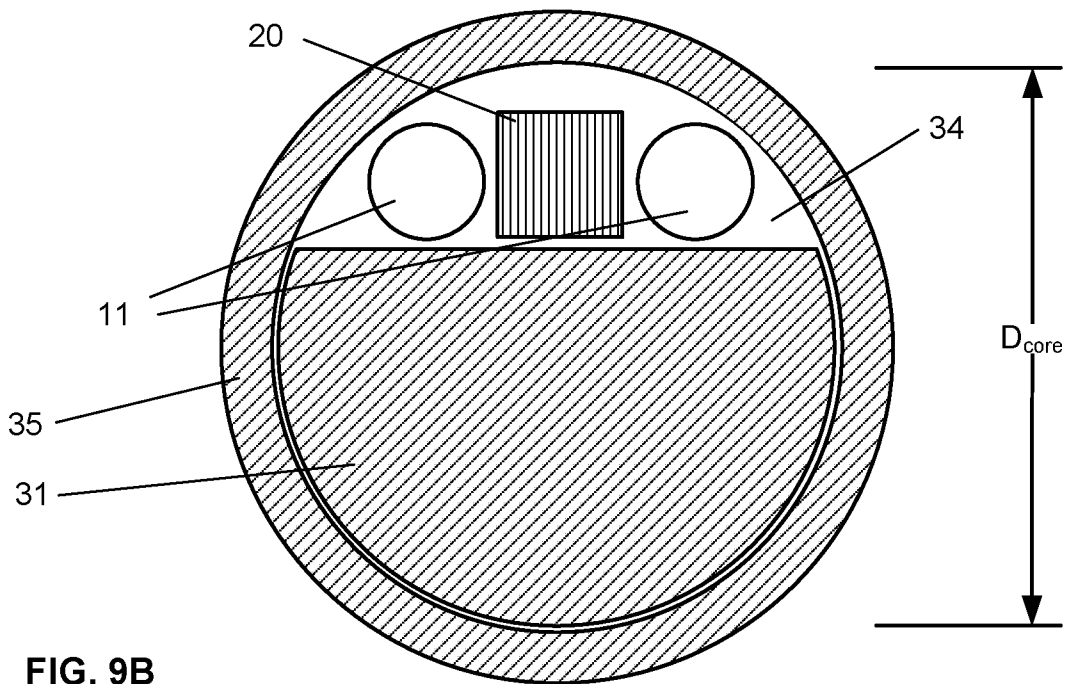

FIG. 9B

C-C CUT-THROUGH VIEW OF FIG. 5B

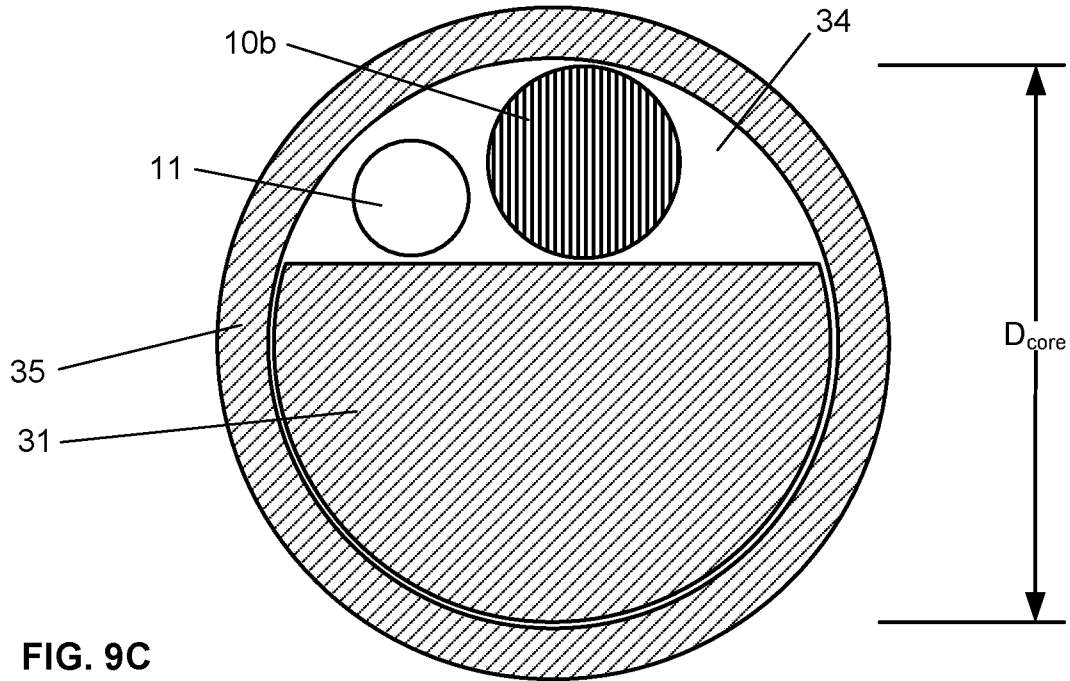

FIG. 9C

D-D CUT-THROUGH VIEW OF FIG. 5B

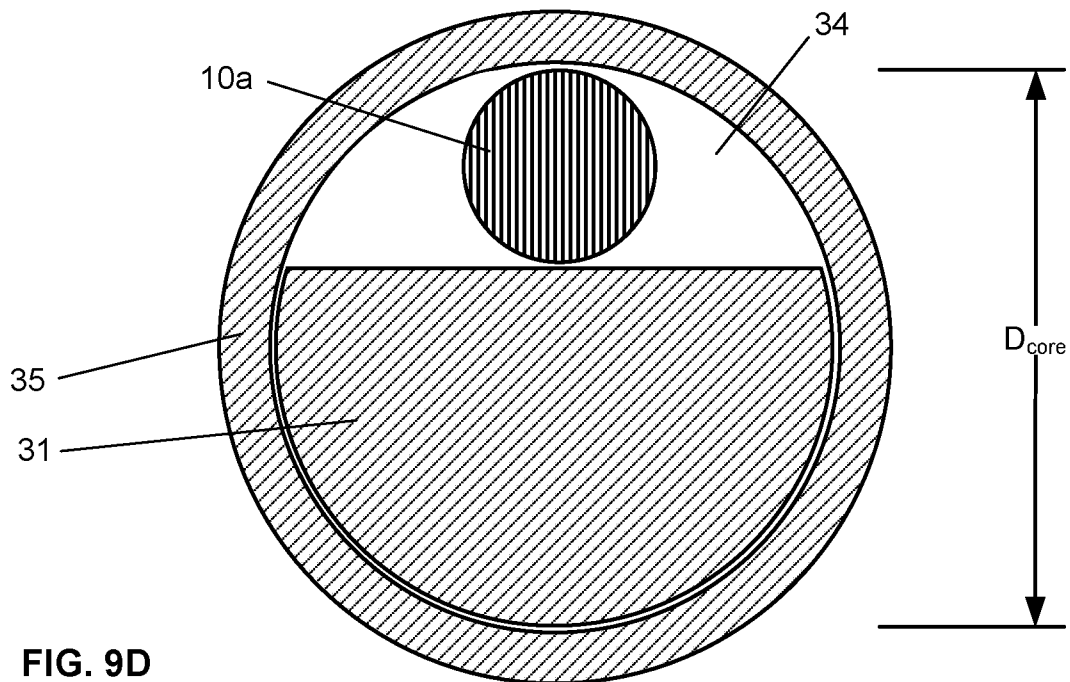

FIG. 9D

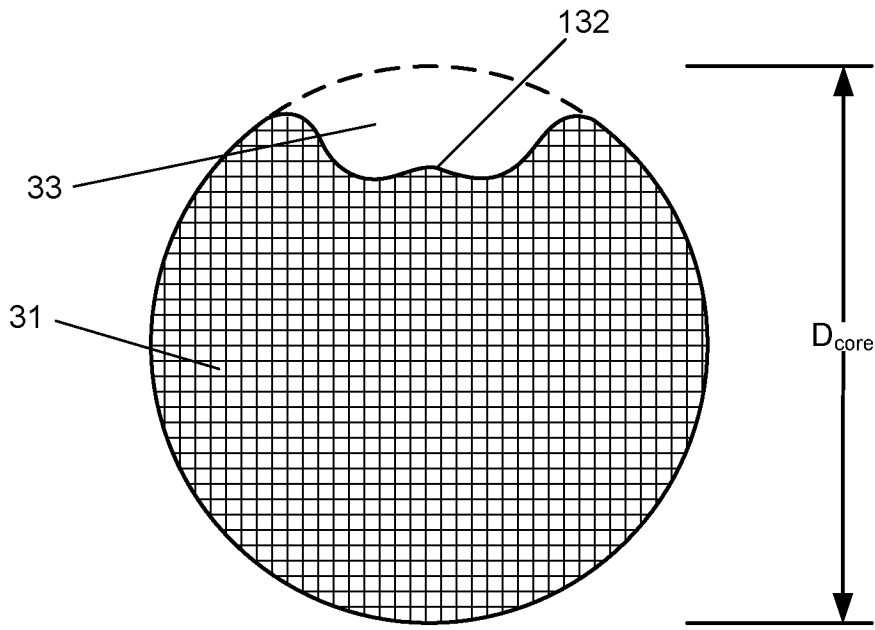

FIG. 10A

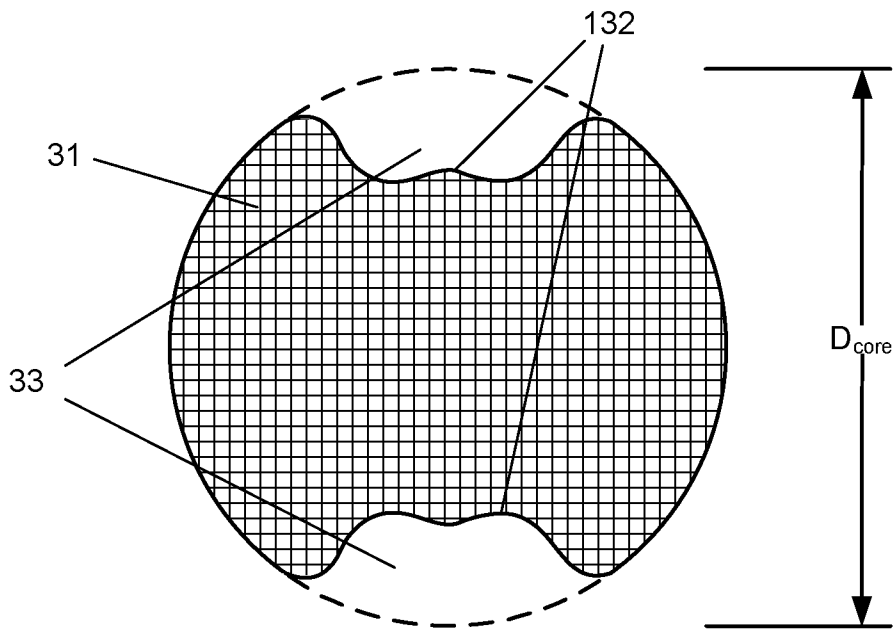

FIG. 10B

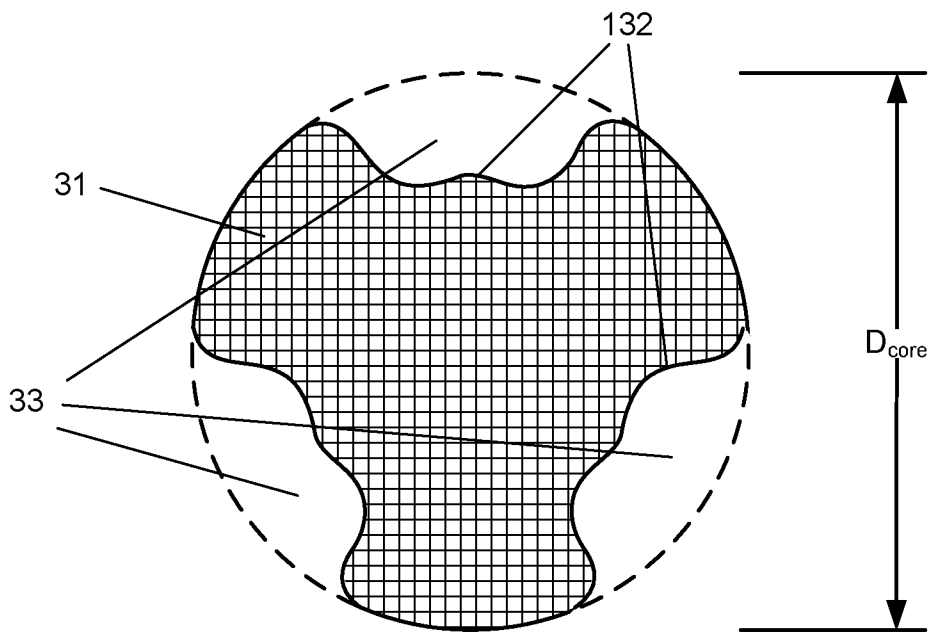

FIG. 10C

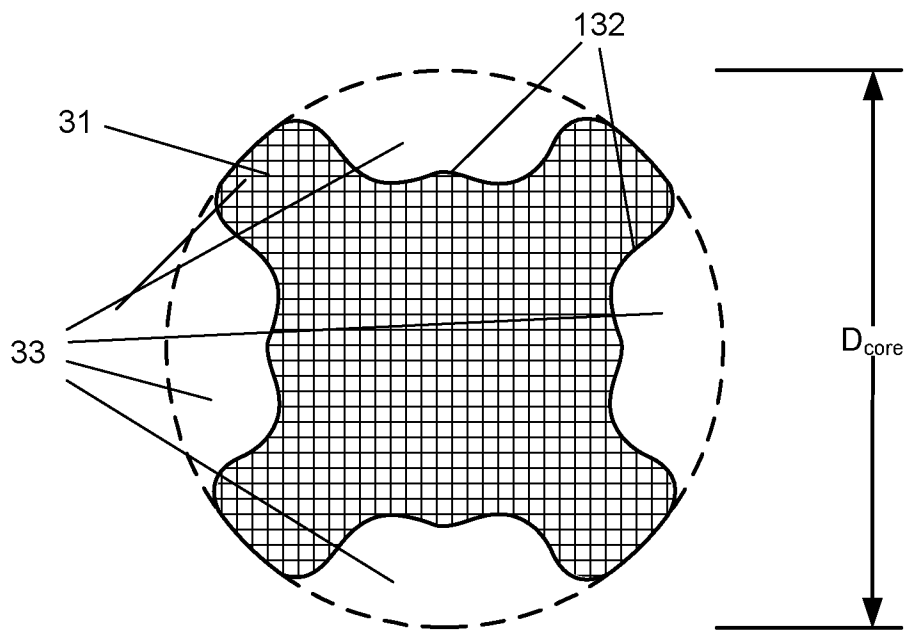

FIG. 10D

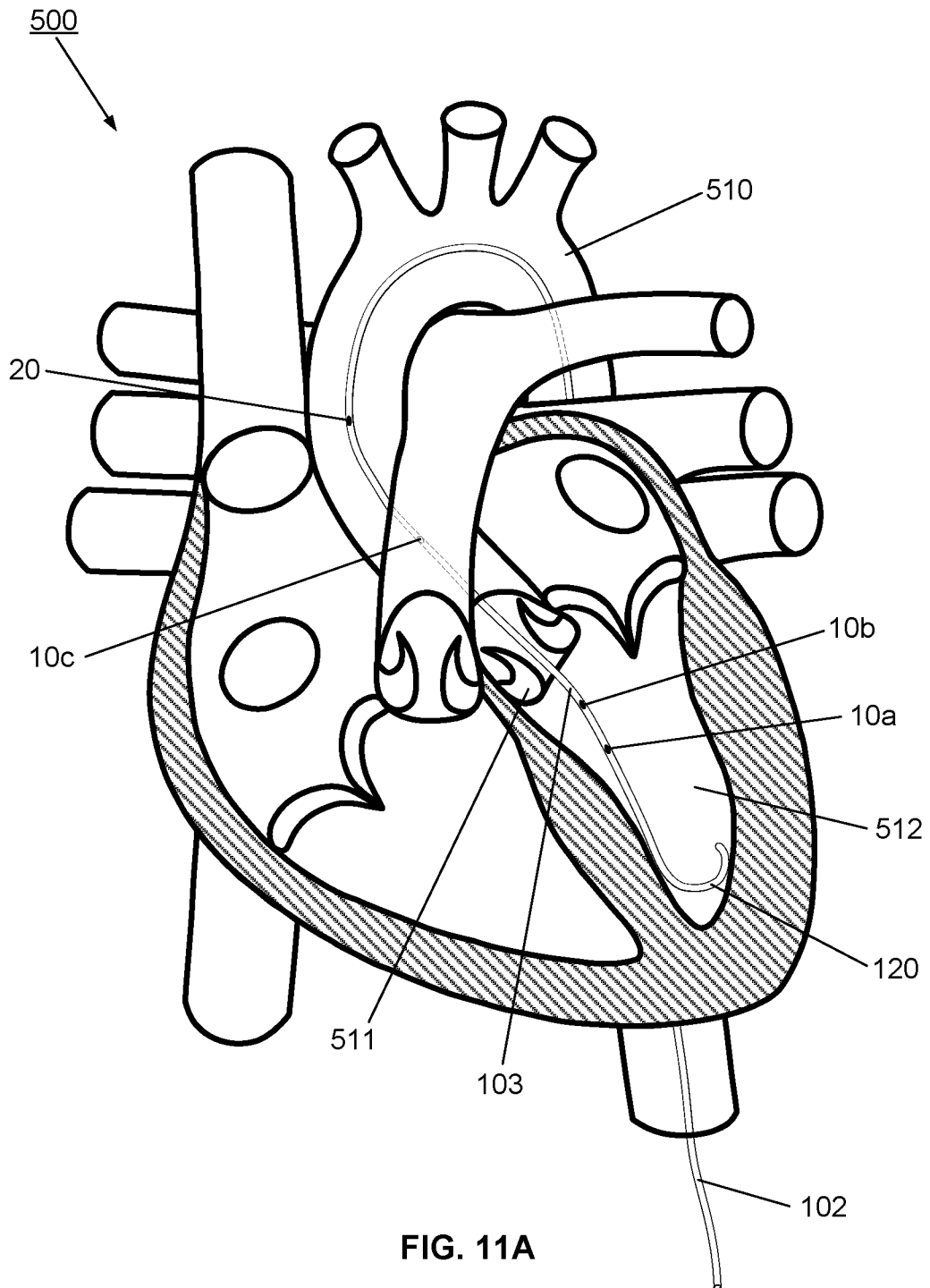
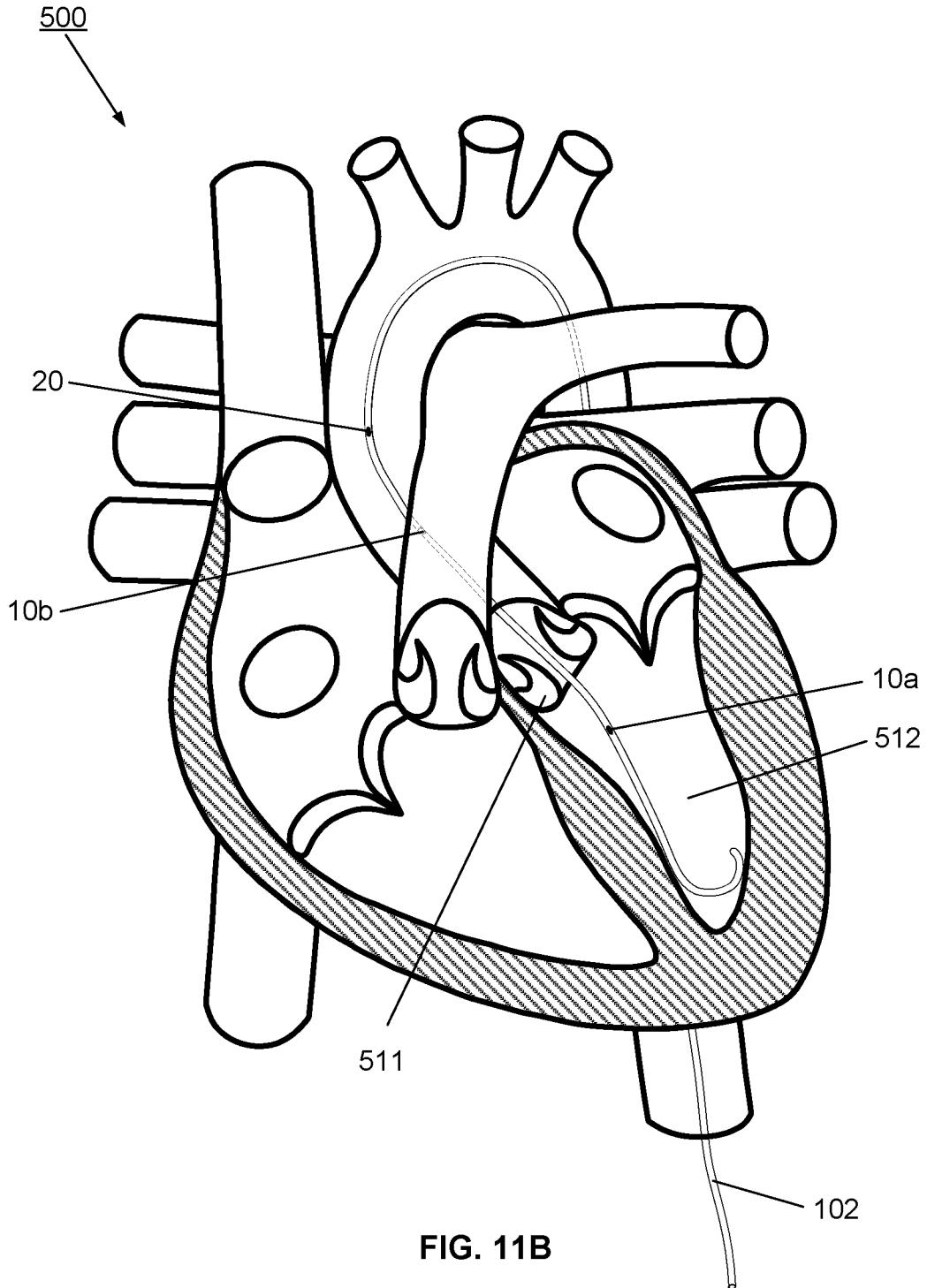
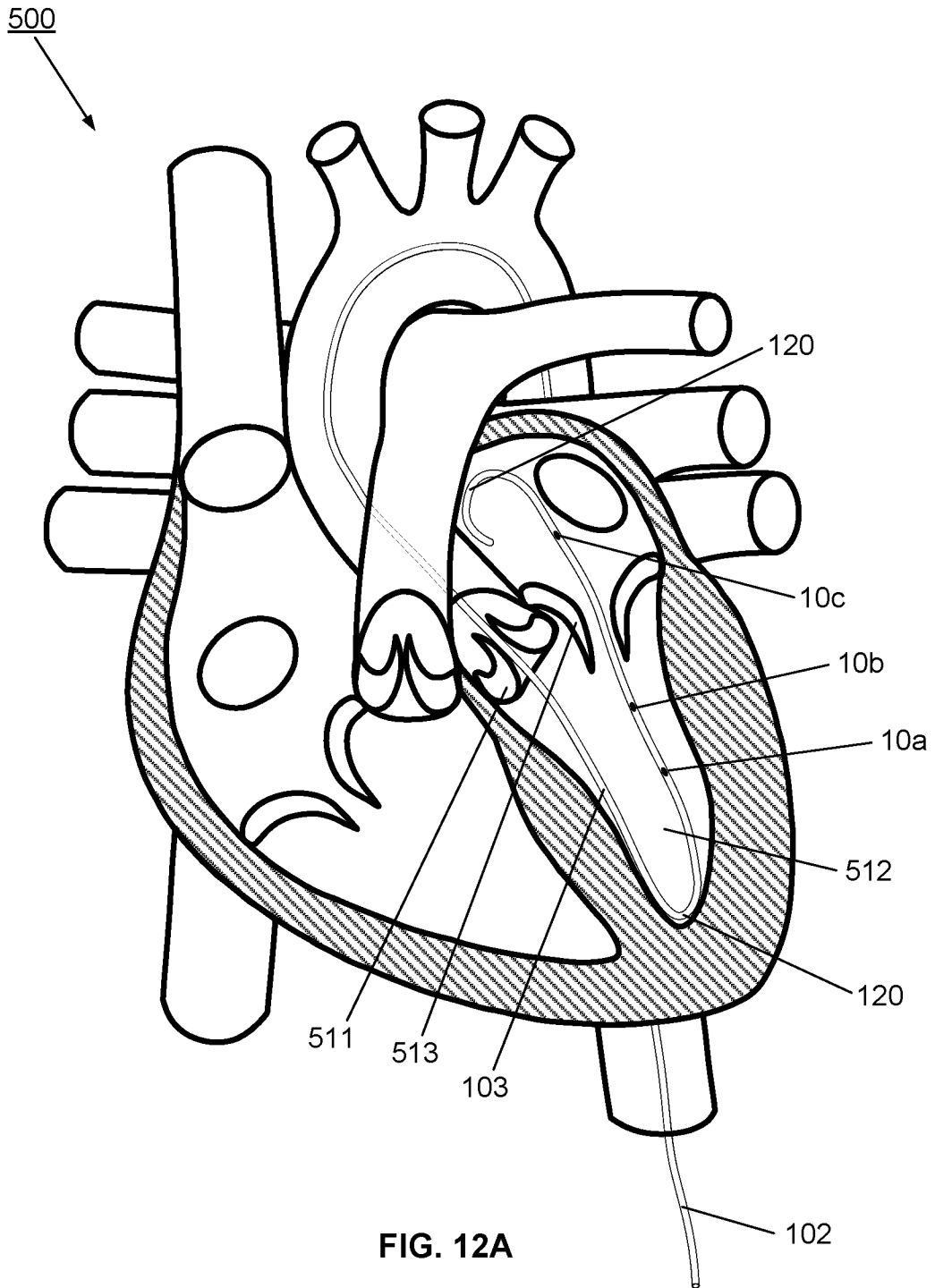

FIG. 11A





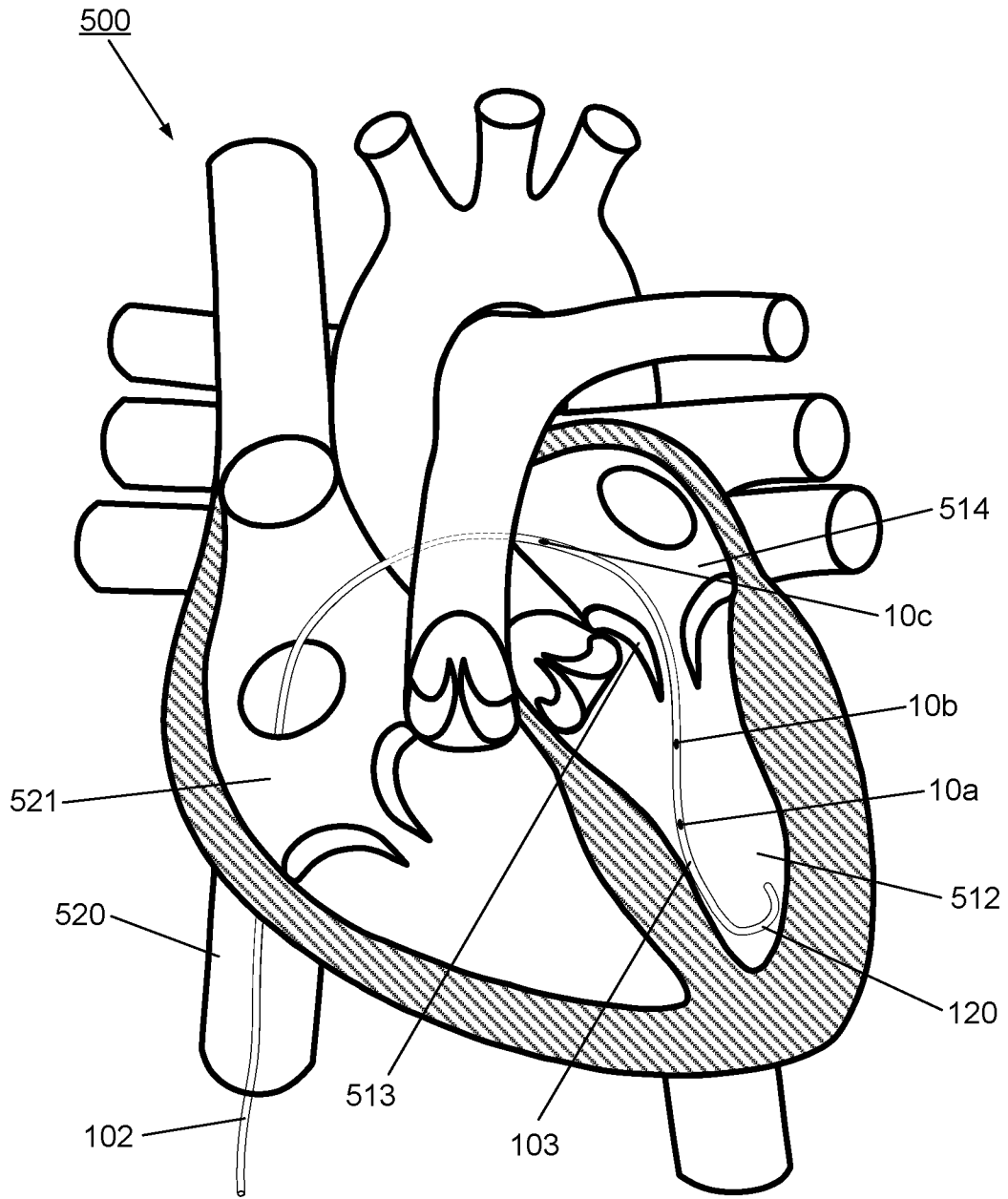

FIG. 12B

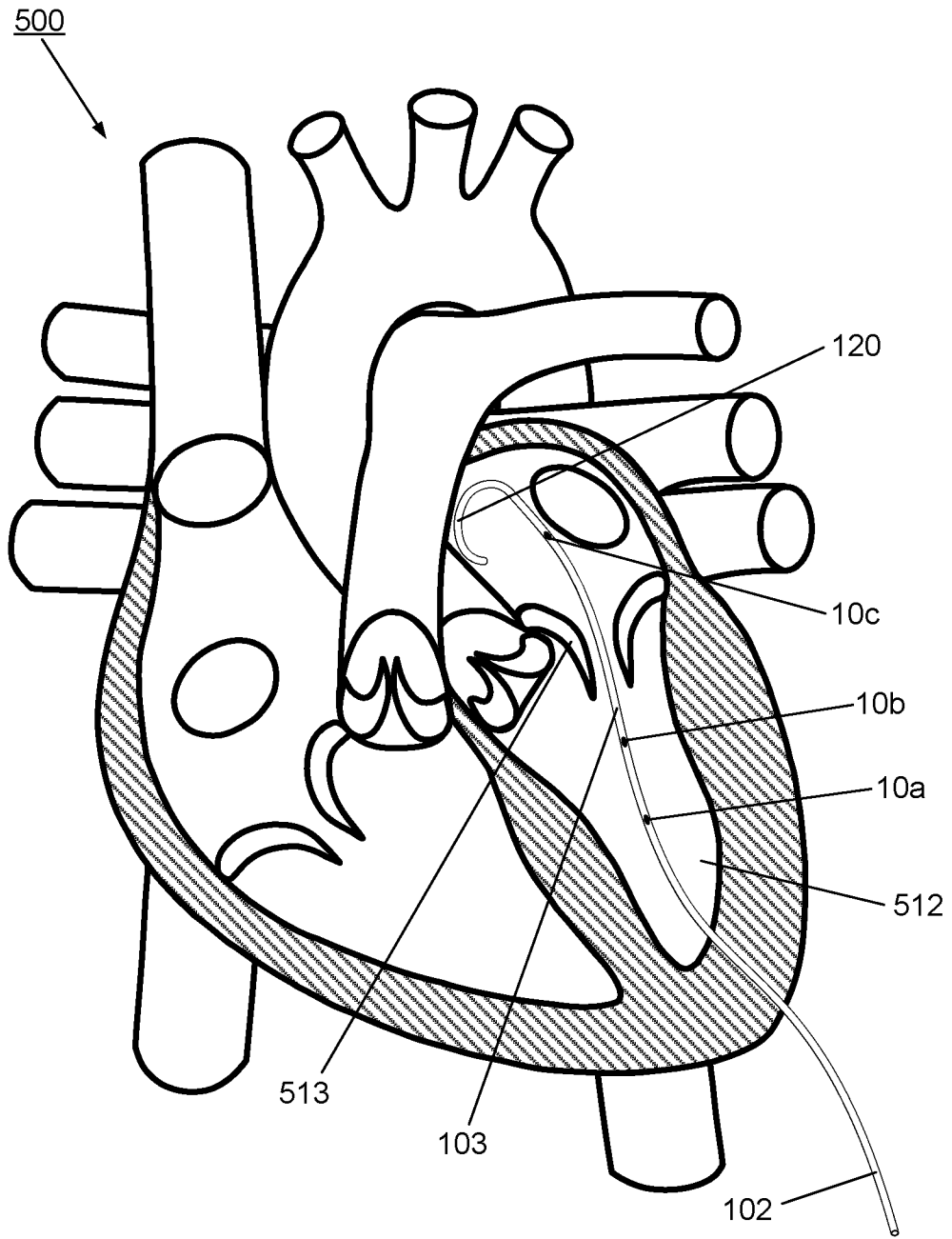

FIG. 12C

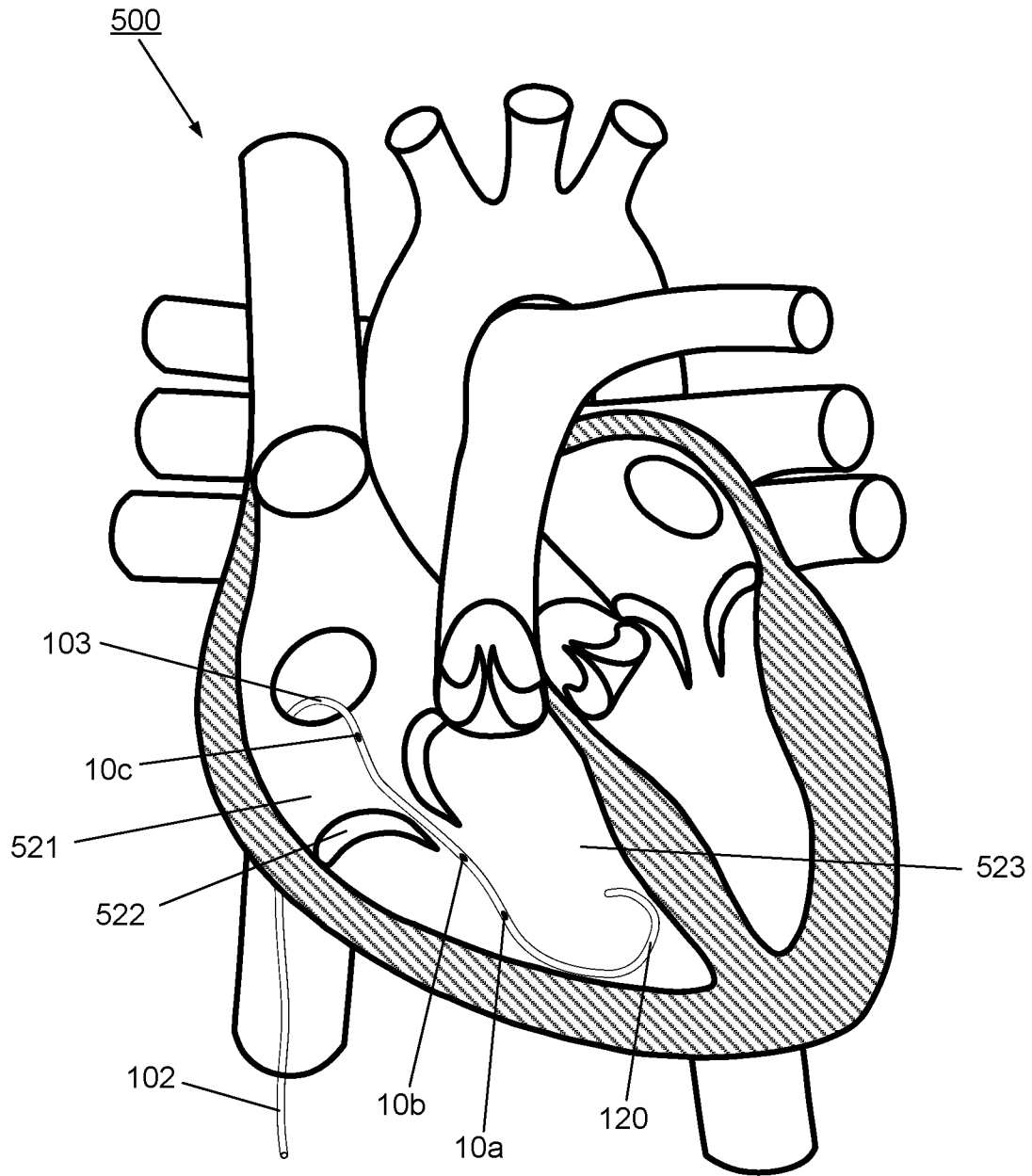

FIG. 13

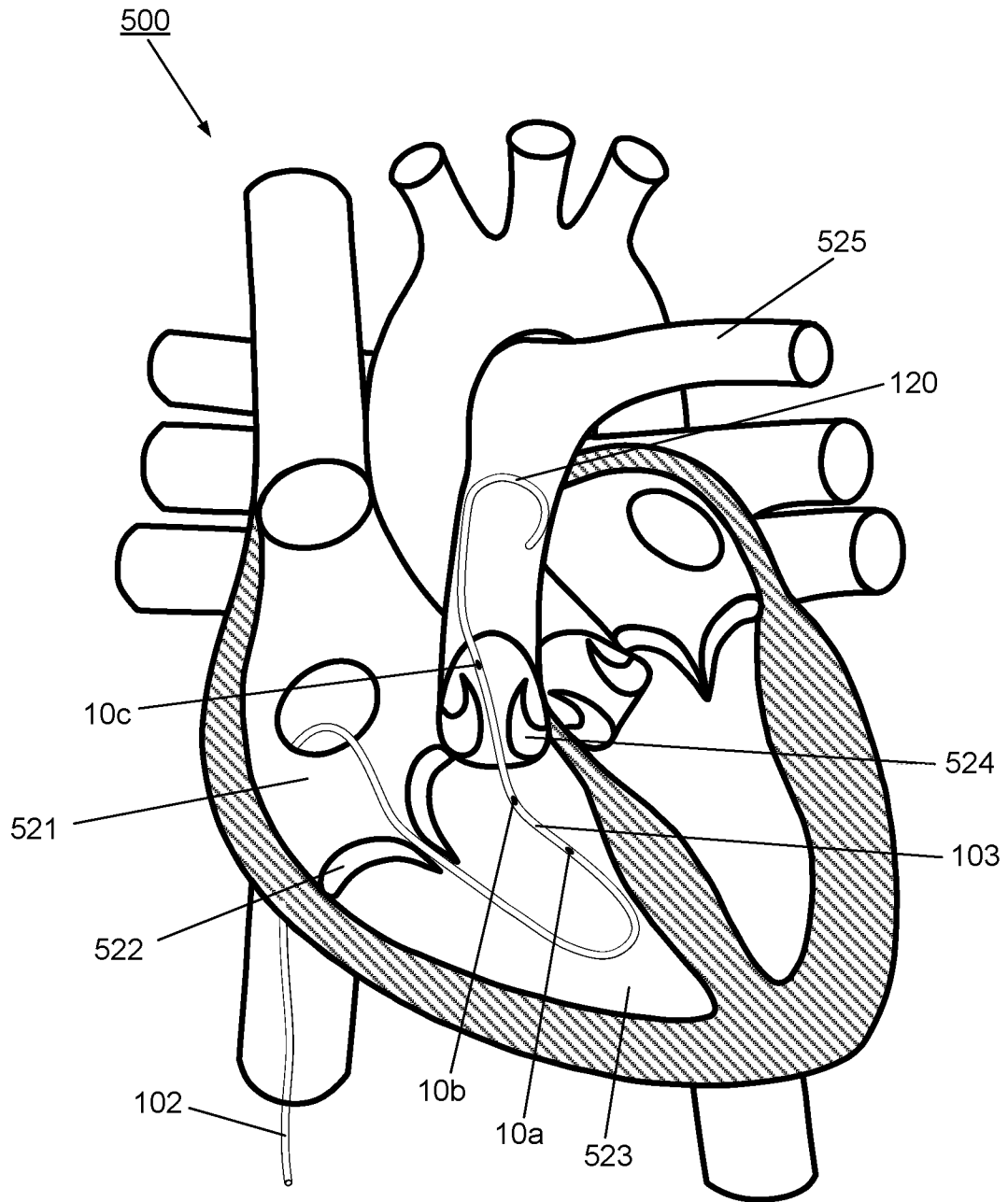

FIG. 14

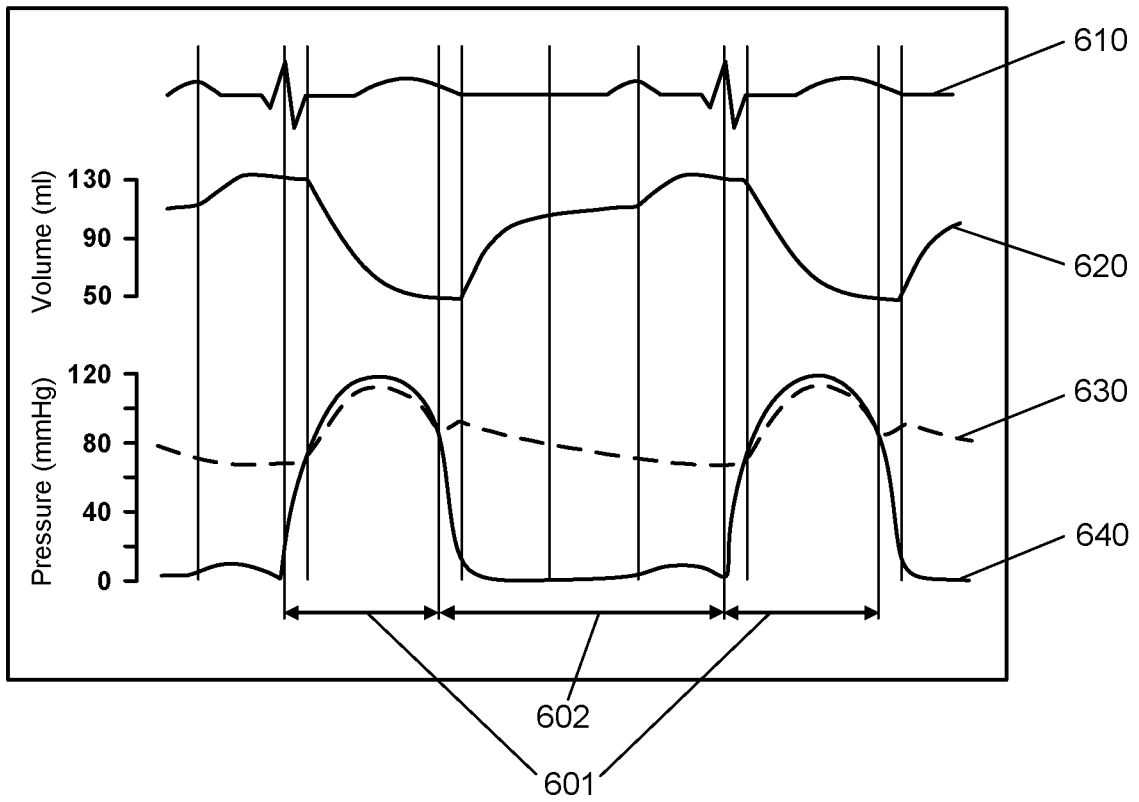
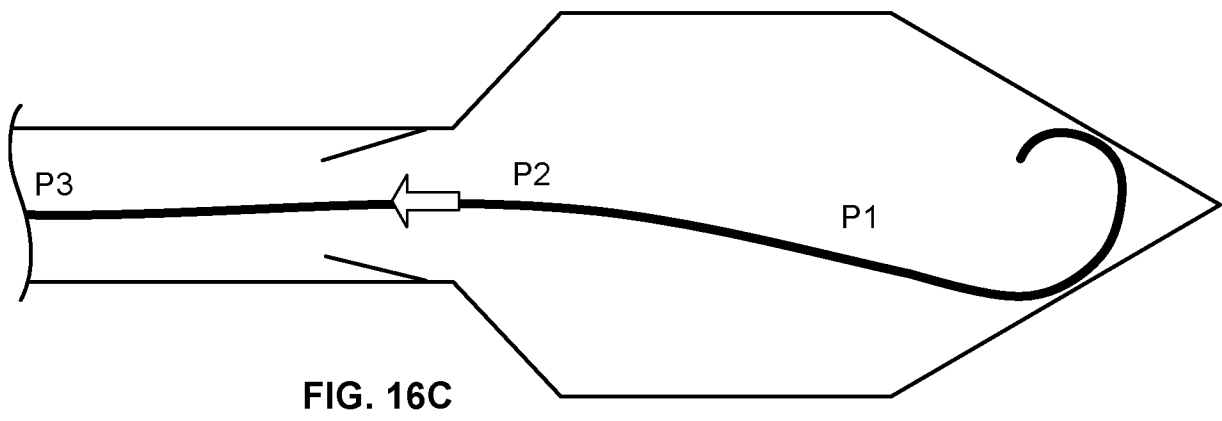
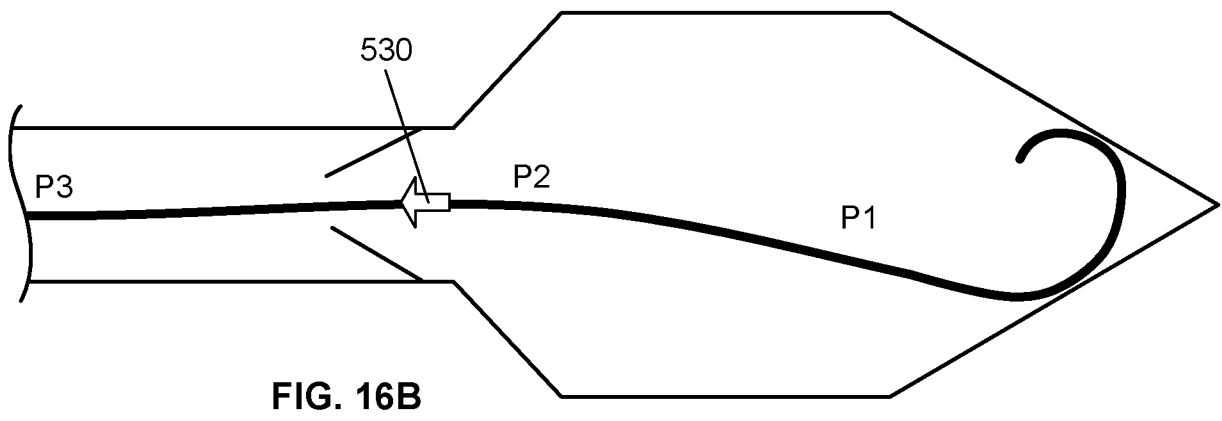
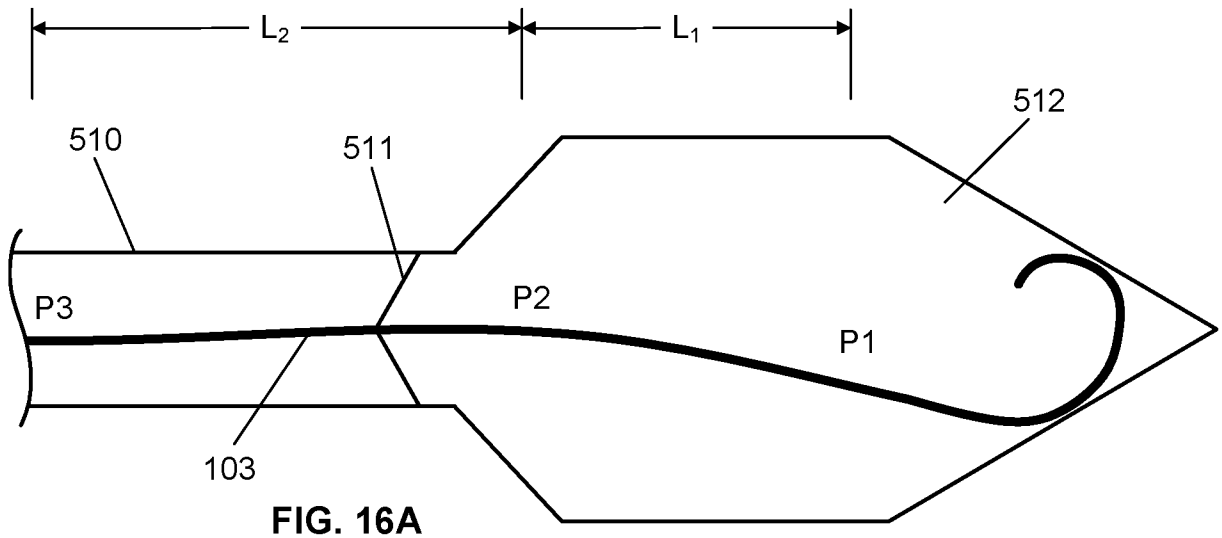

FIG. 15

$P1 = P2 > P3$



$P1 > P2 > P3$

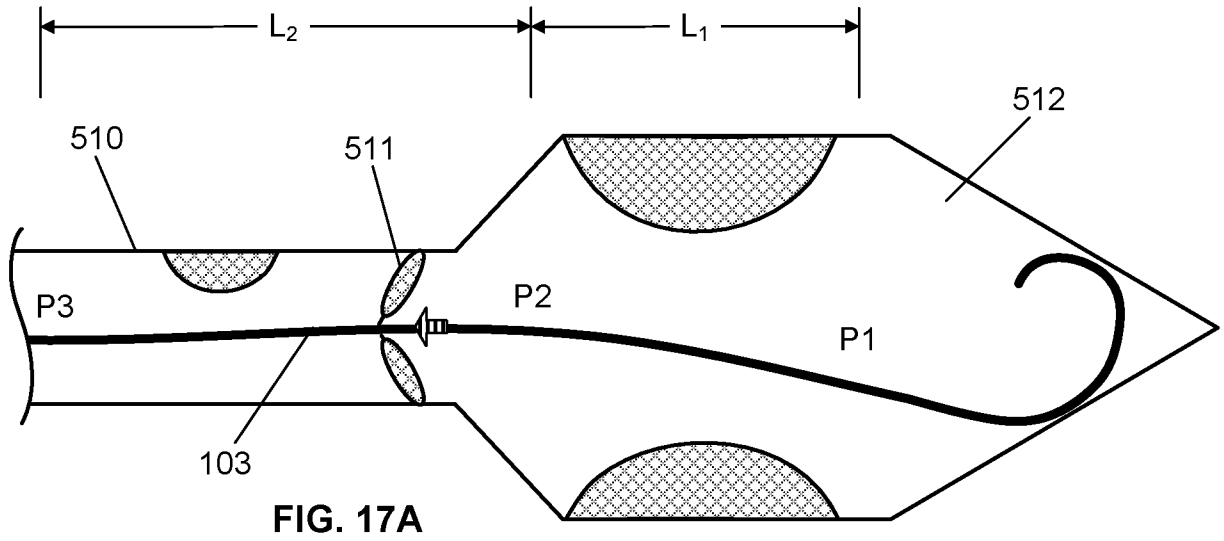

FIG. 17A

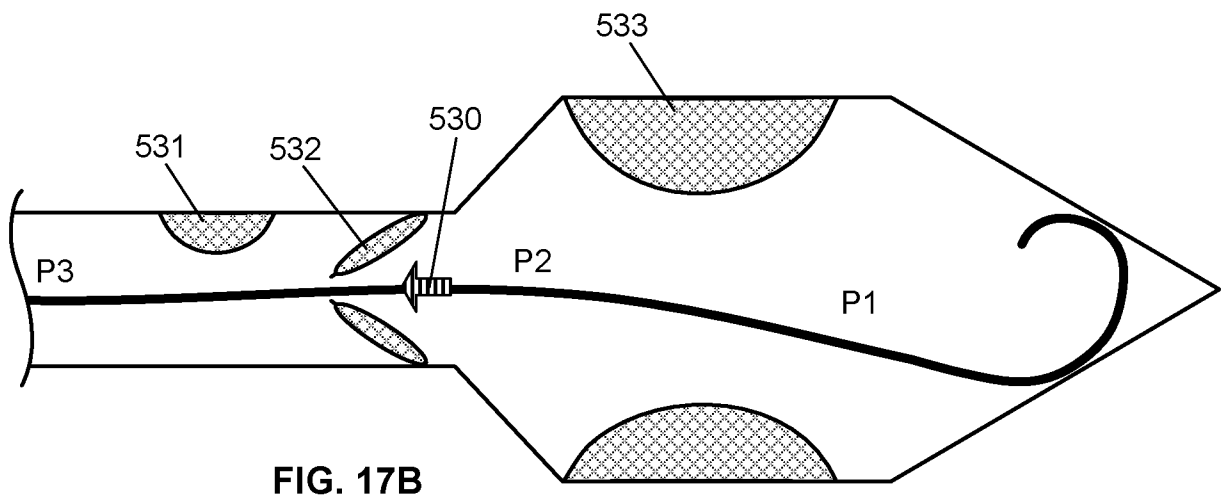

FIG. 17B

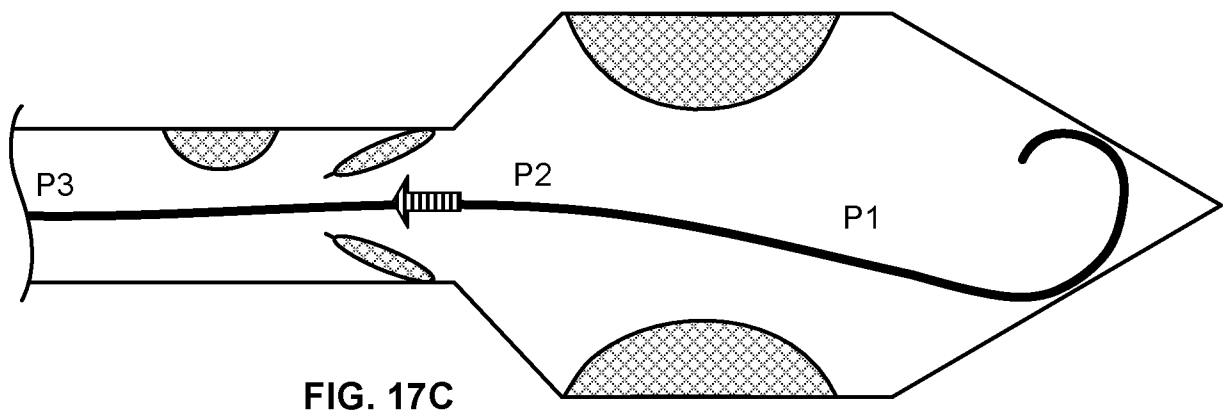

FIG. 17C

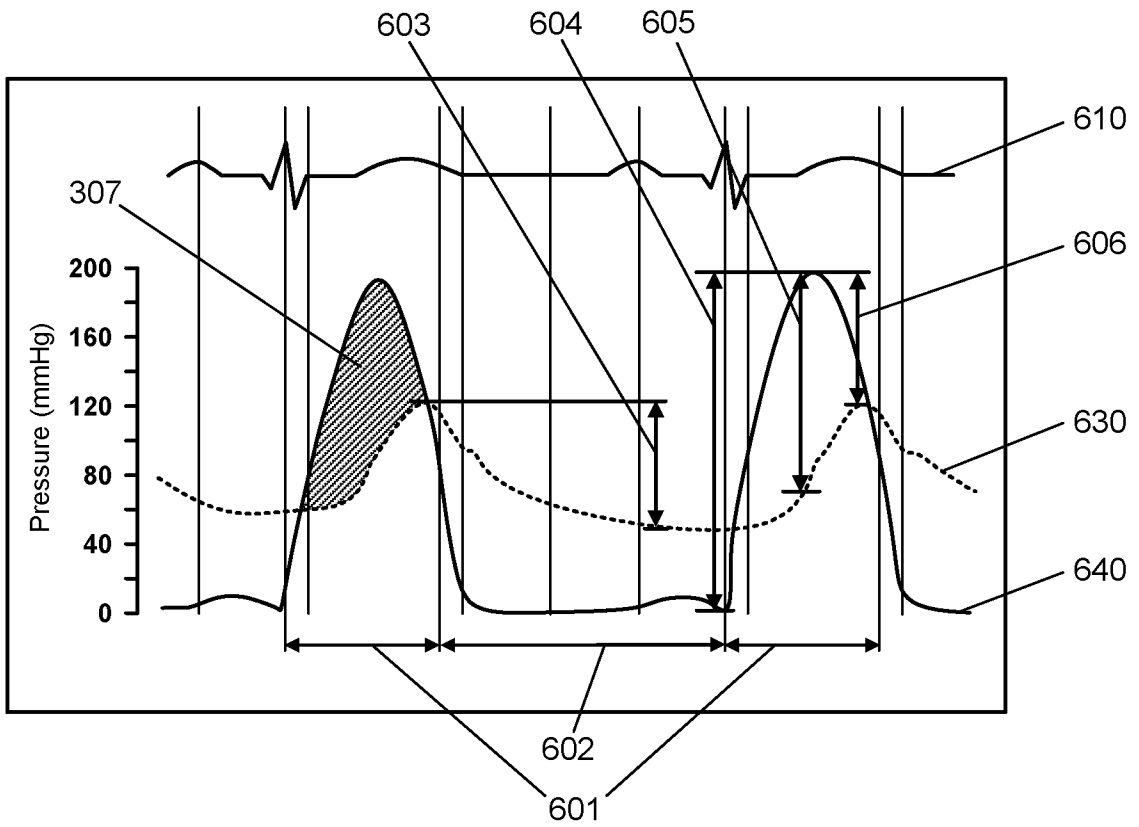

FIG. 18

27/38

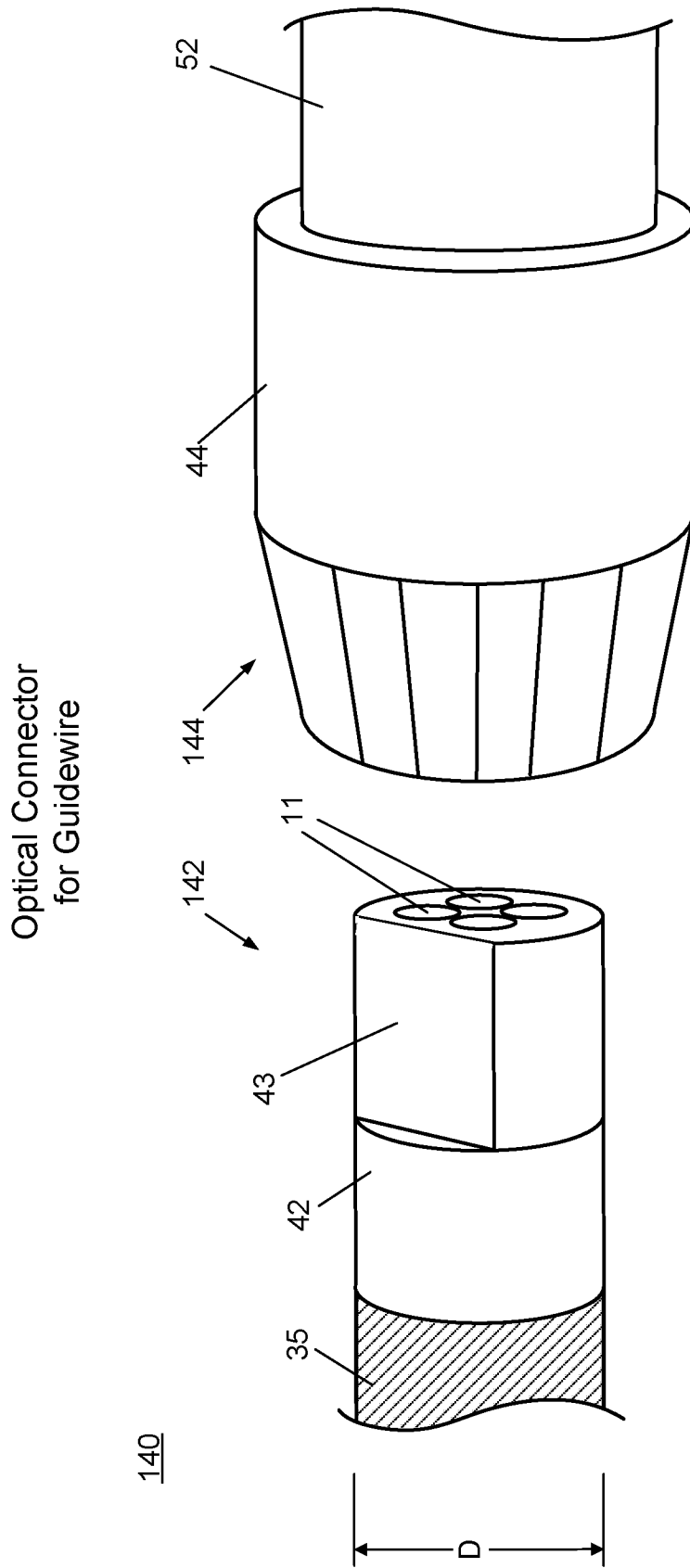

FIG. 19

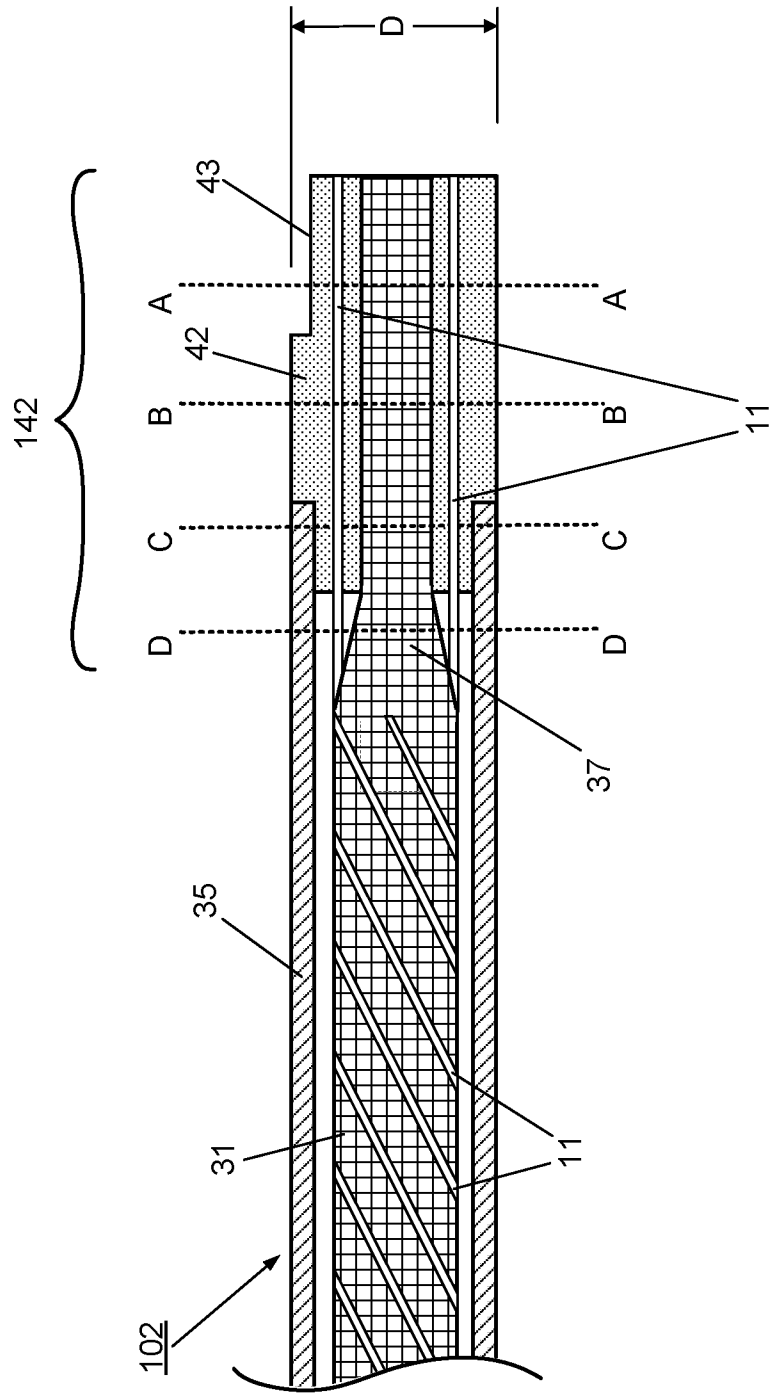

FIG. 20

A-A CUT-THROUGH VIEW OF FIG. 20

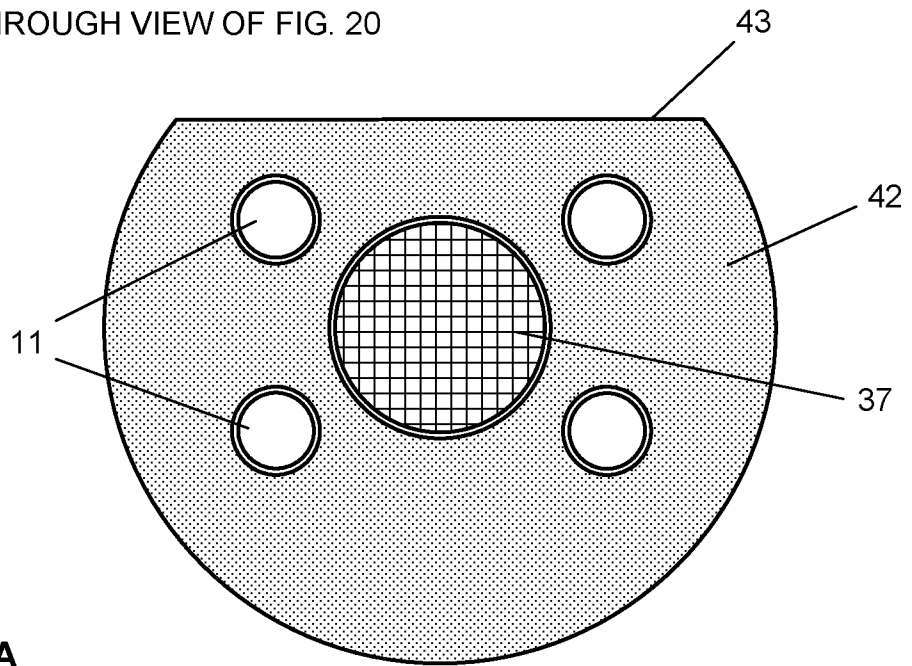

FIG. 21A

B-B CUT-THROUGH VIEW OF FIG. 20

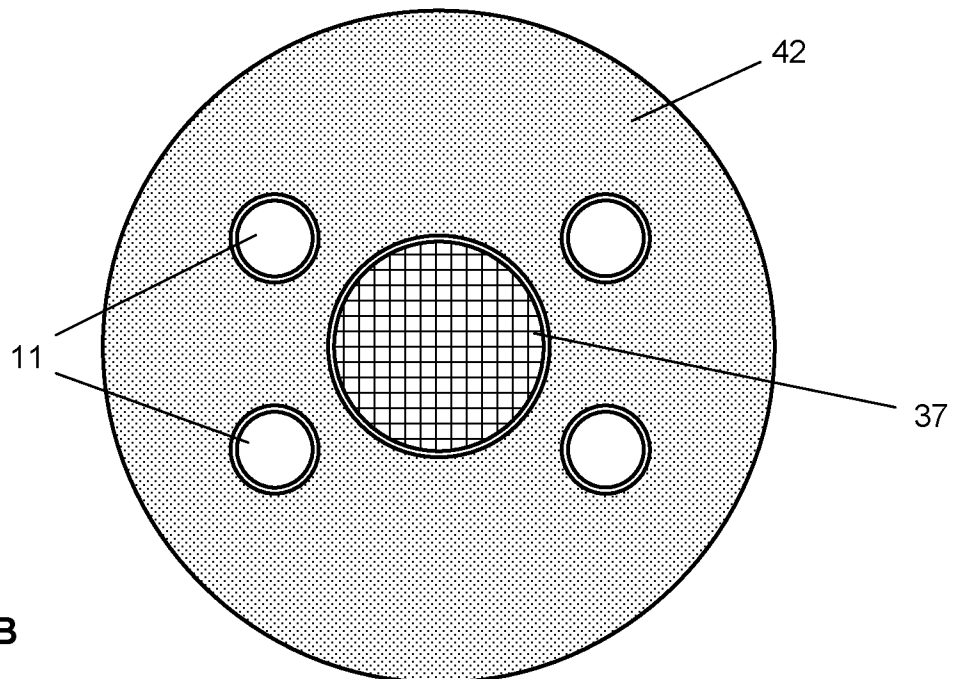

FIG. 21B

C-C CUT-THROUGH VIEW OF FIG. 20

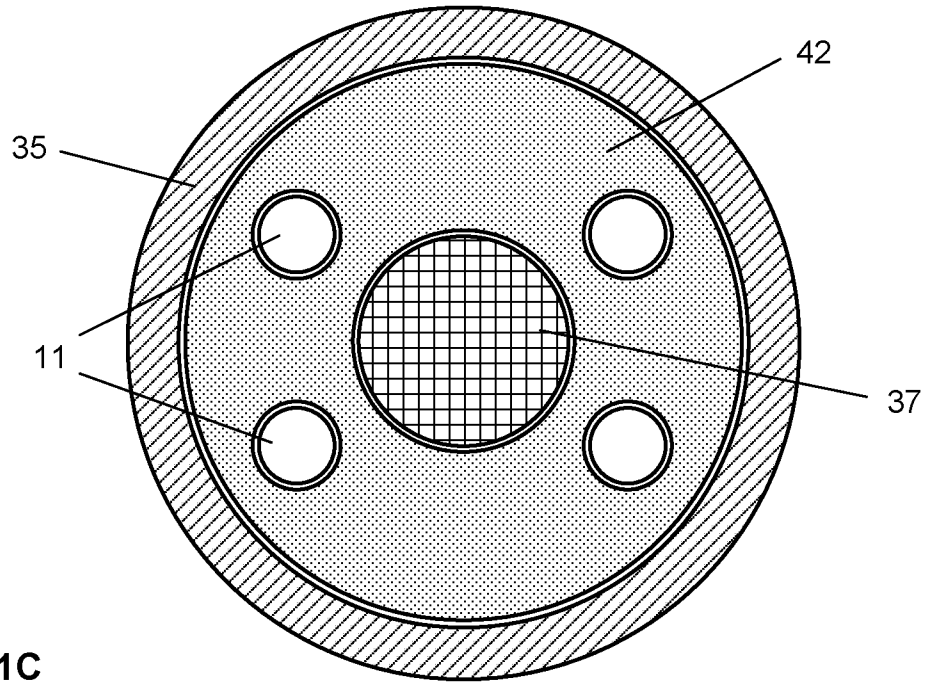

FIG. 21C

D-D CUT-THROUGH VIEW OF FIG. 20

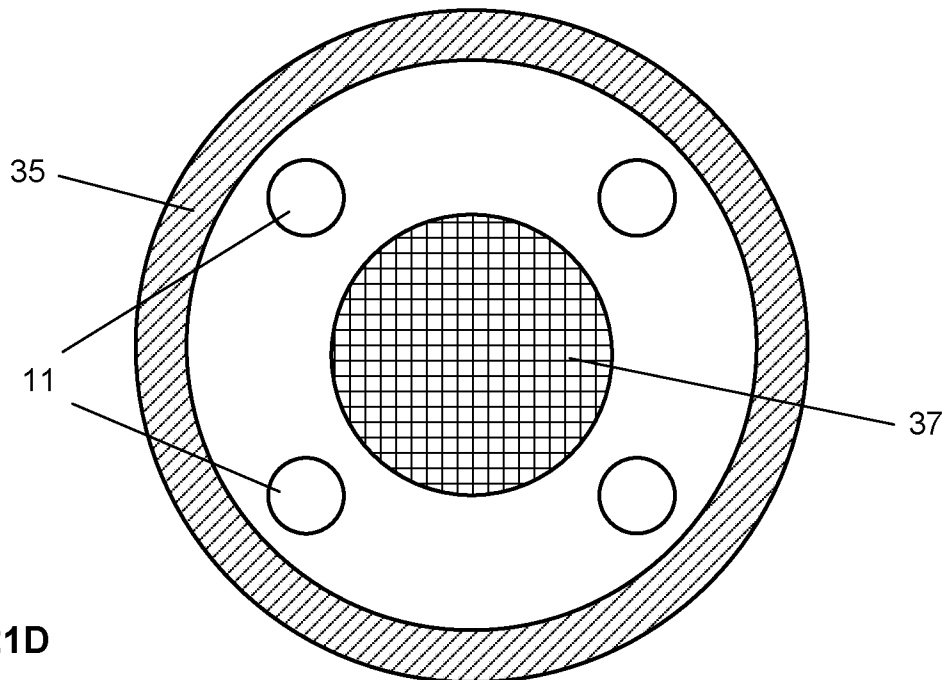

FIG. 21D

31/38

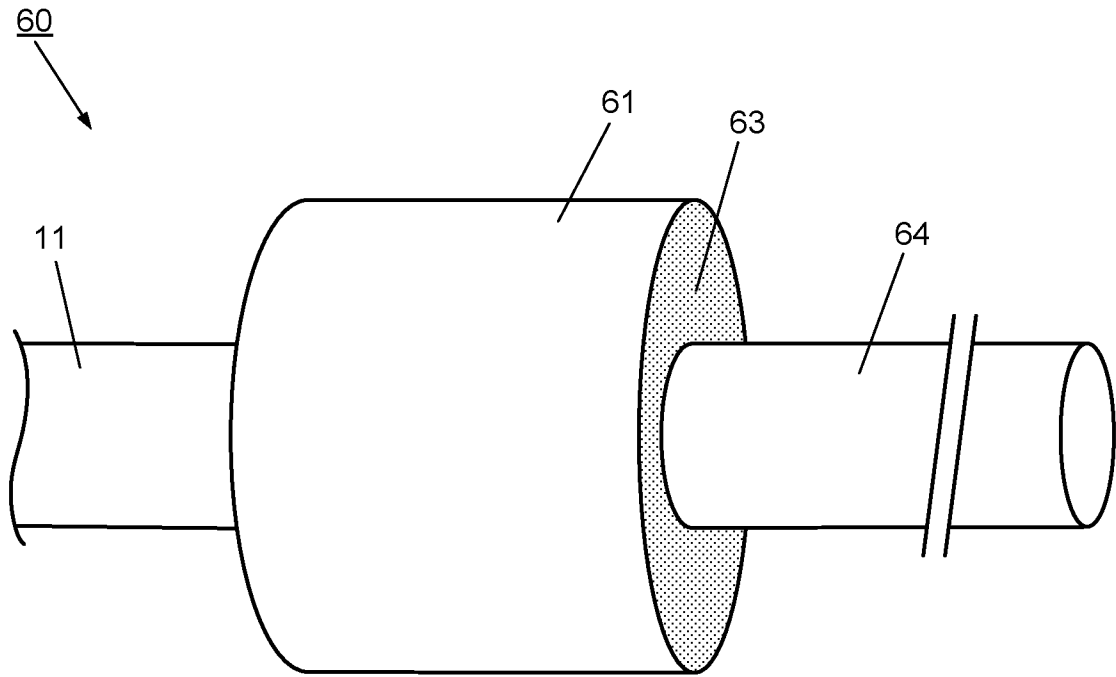

FIG. 22

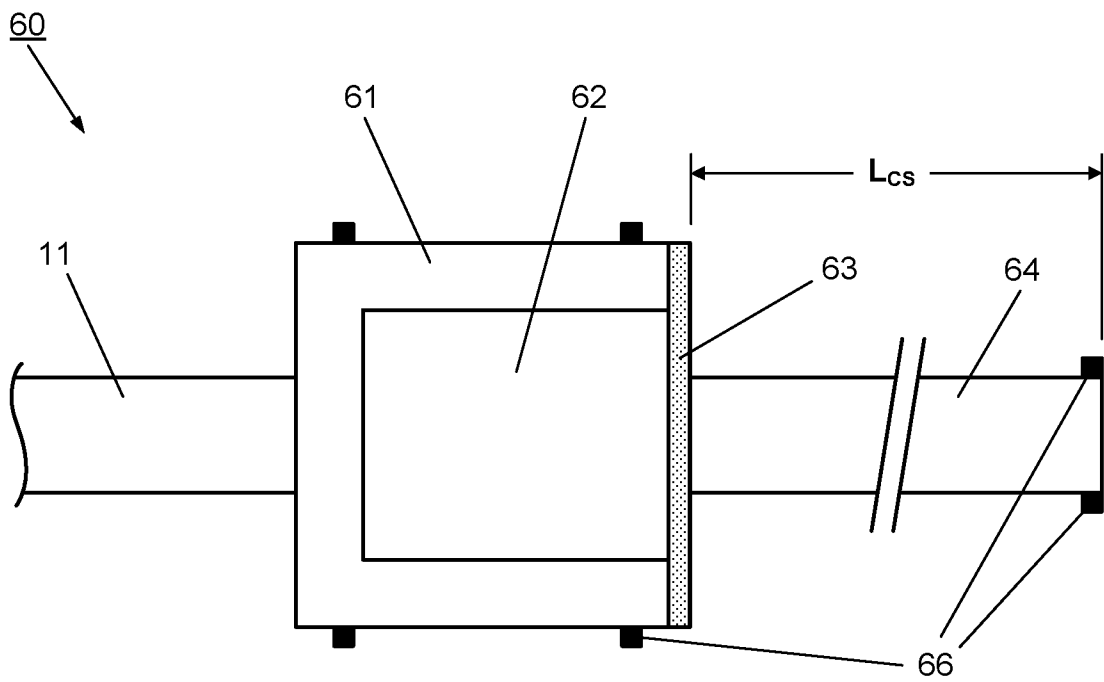

FIG. 23

Distal end equipped with a strain gauge sensor

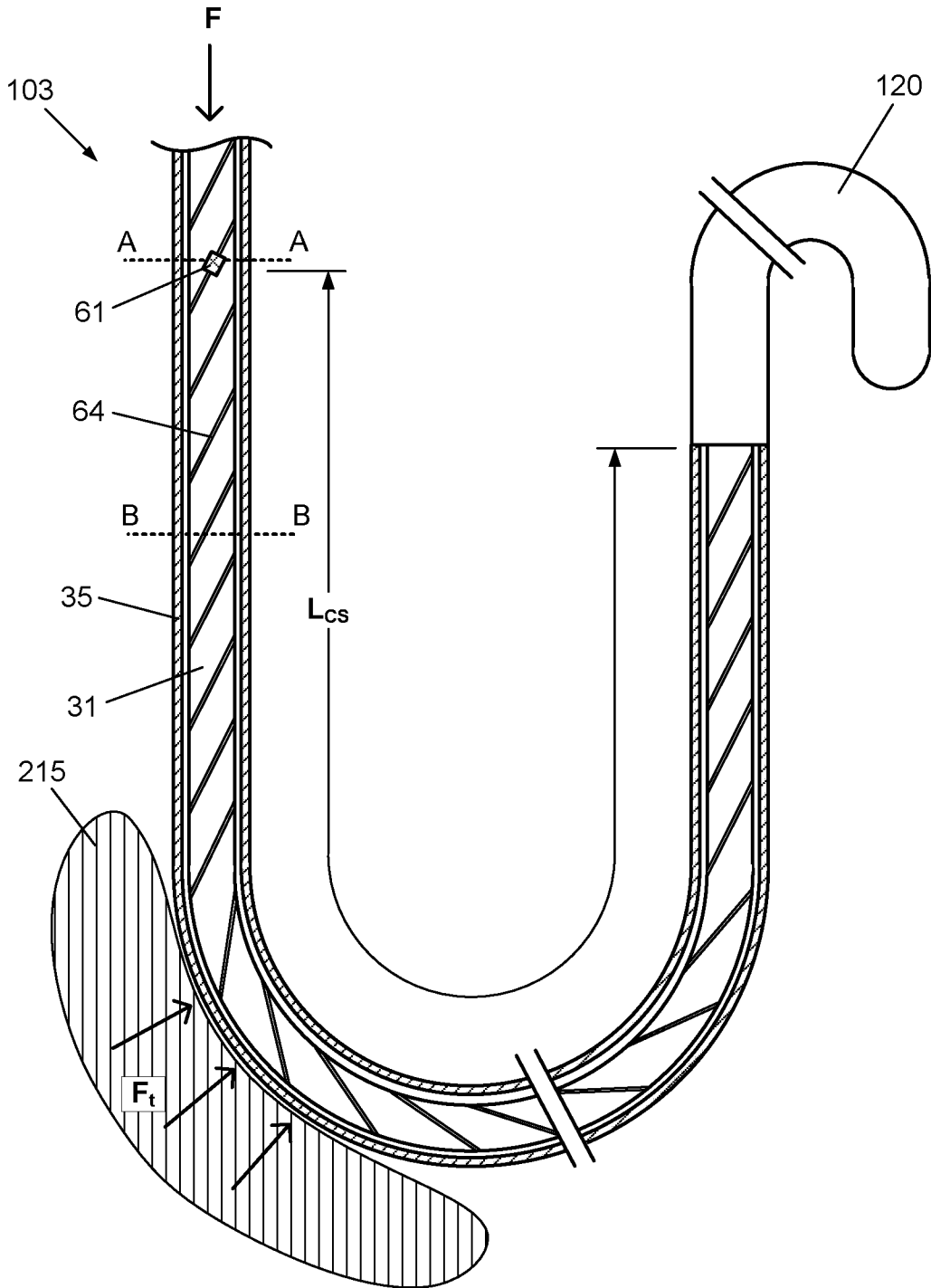

FIG. 24

A-A CUT-THROUGH VIEW OF FIG. 24

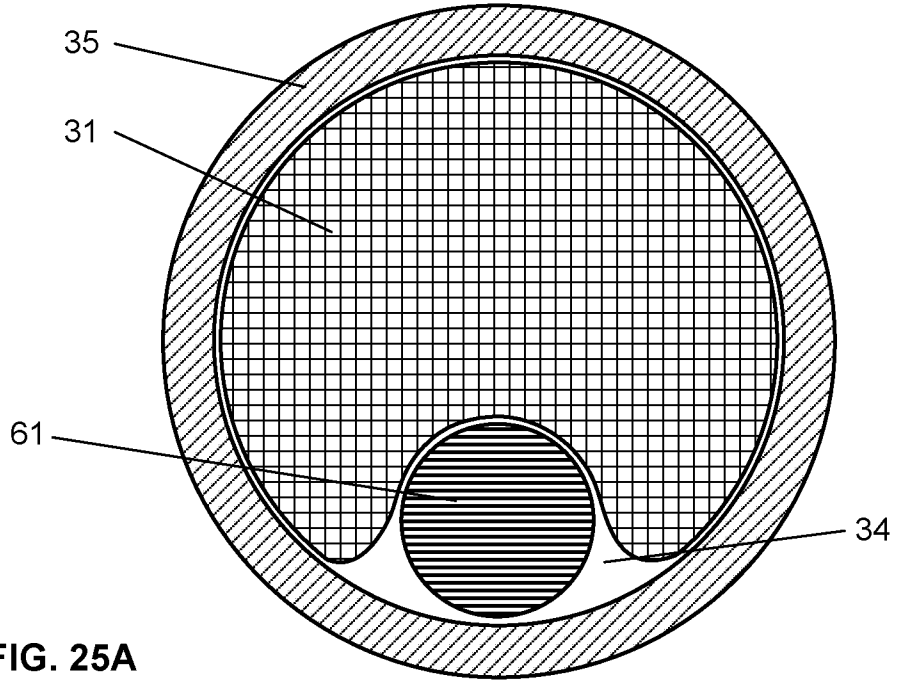

FIG. 25A

B-B CUT-THROUGH VIEW OF FIG. 24

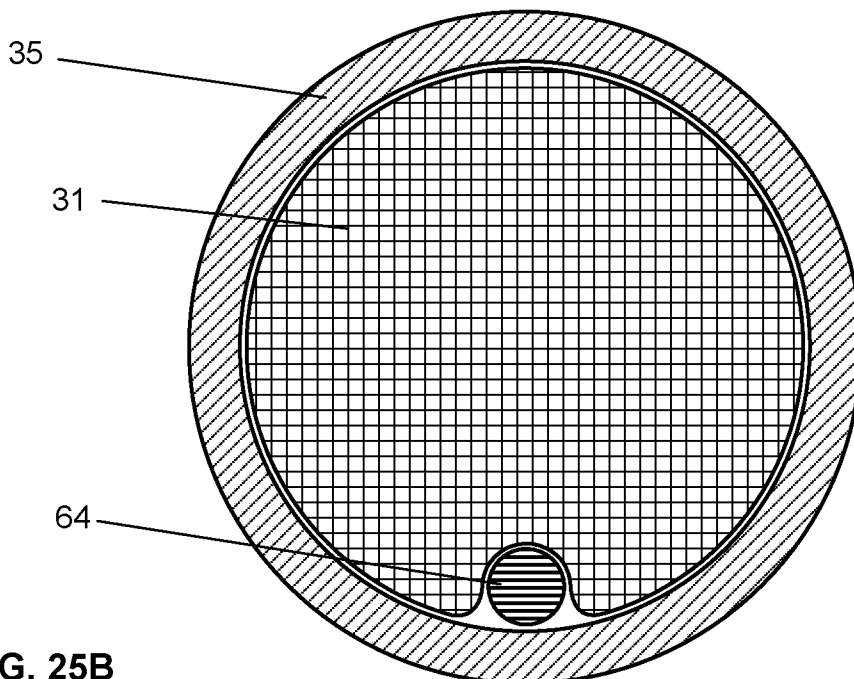

FIG. 25B

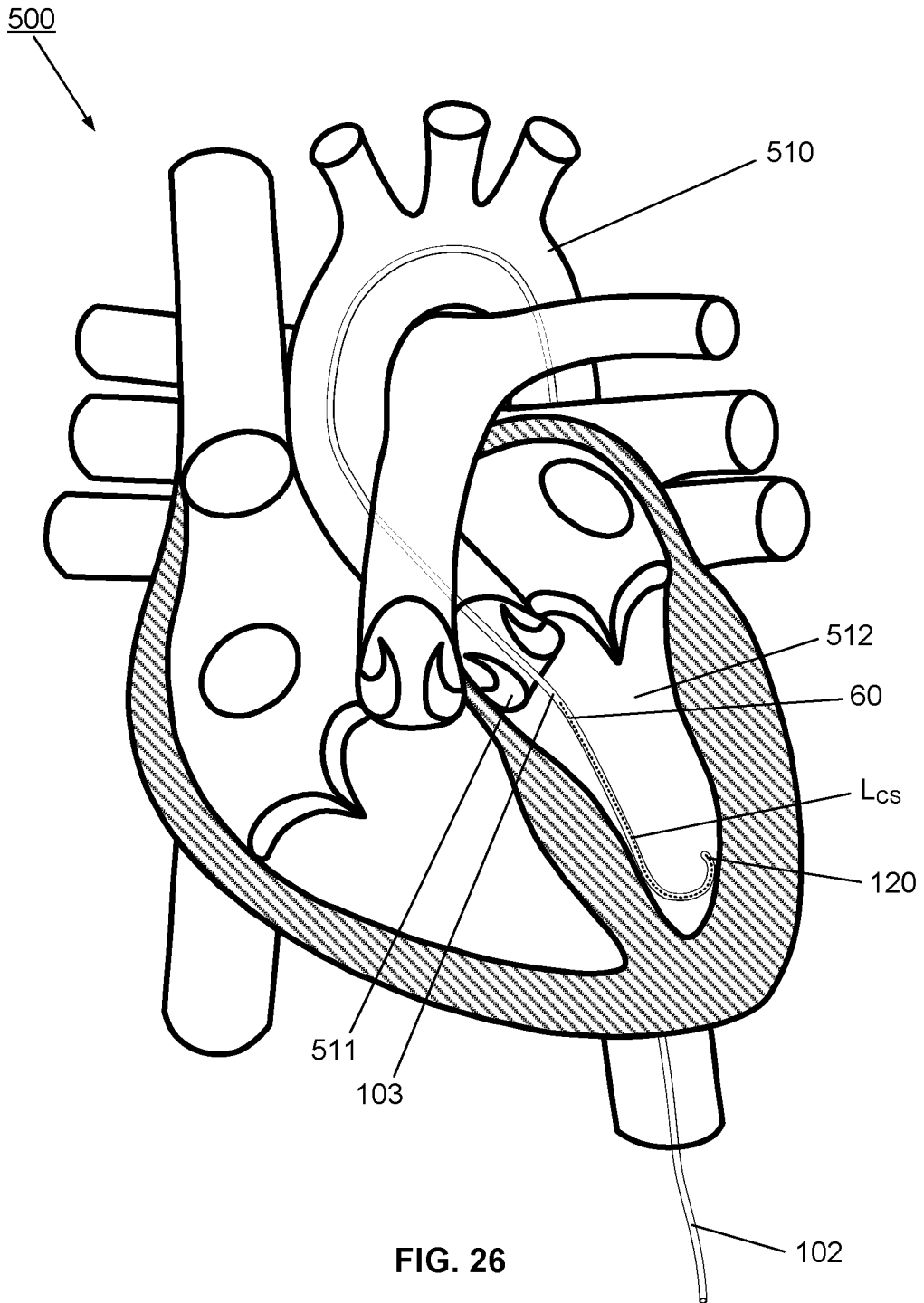

FIG. 26

VIEW FROM A-A OF FIG. 21A

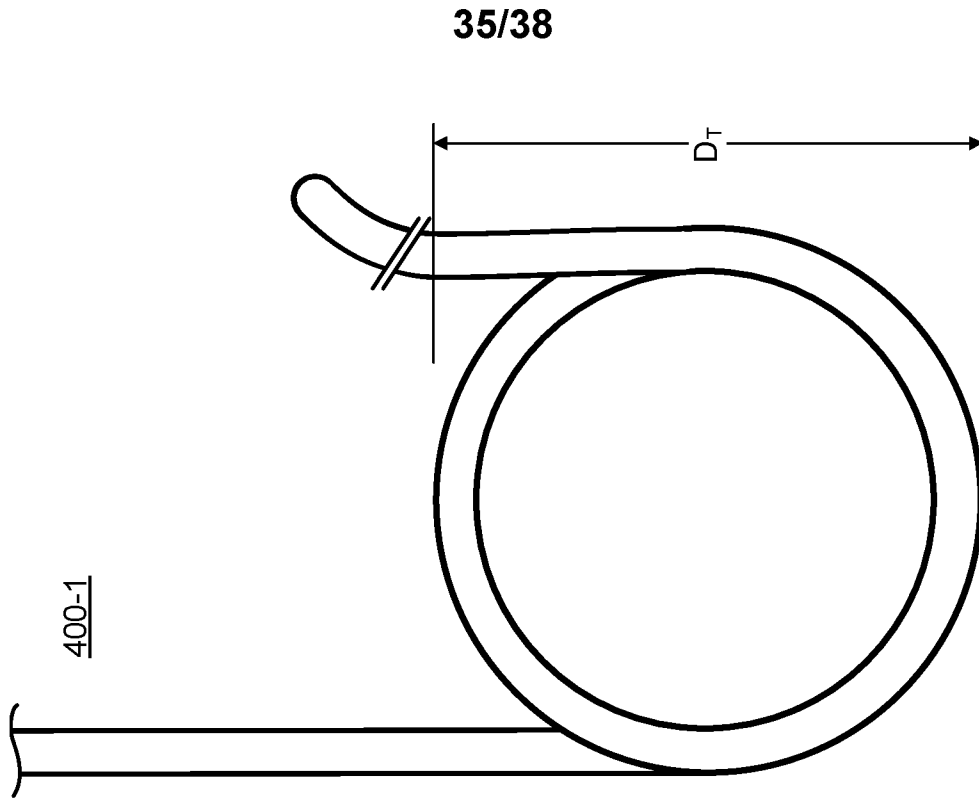

FIG. 27B

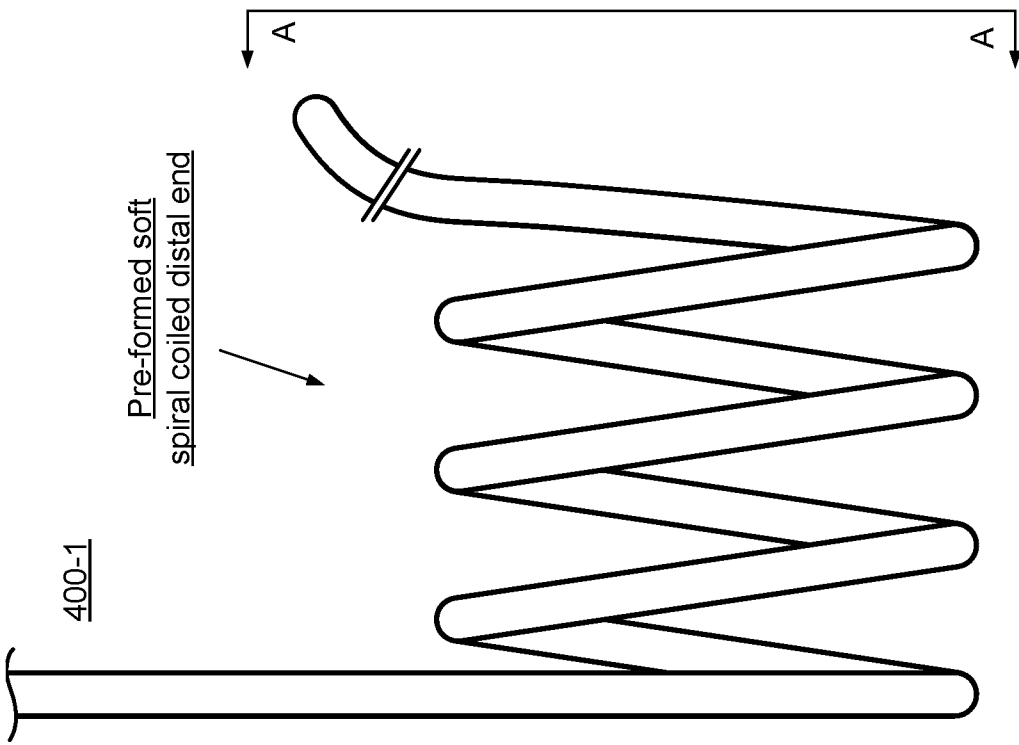
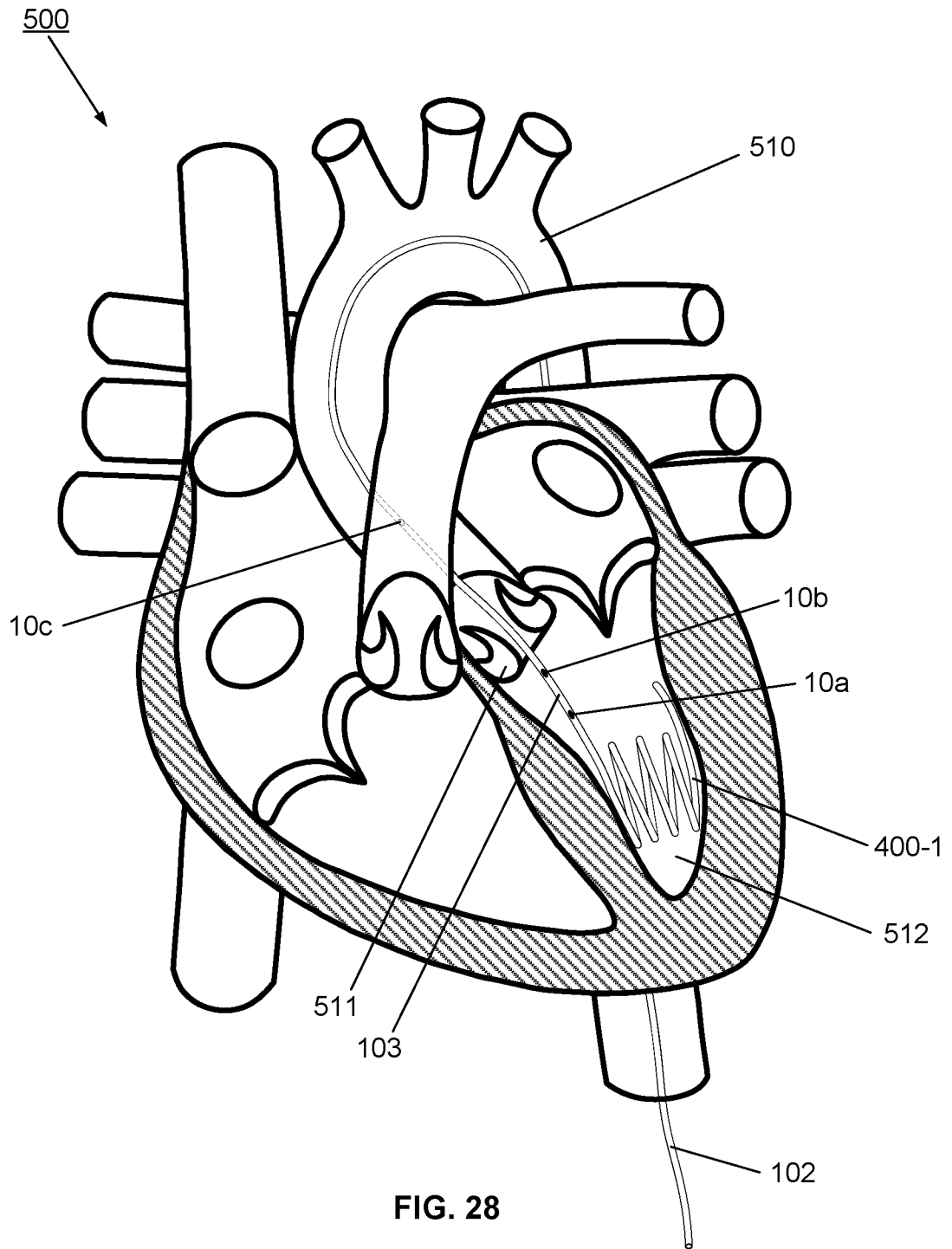
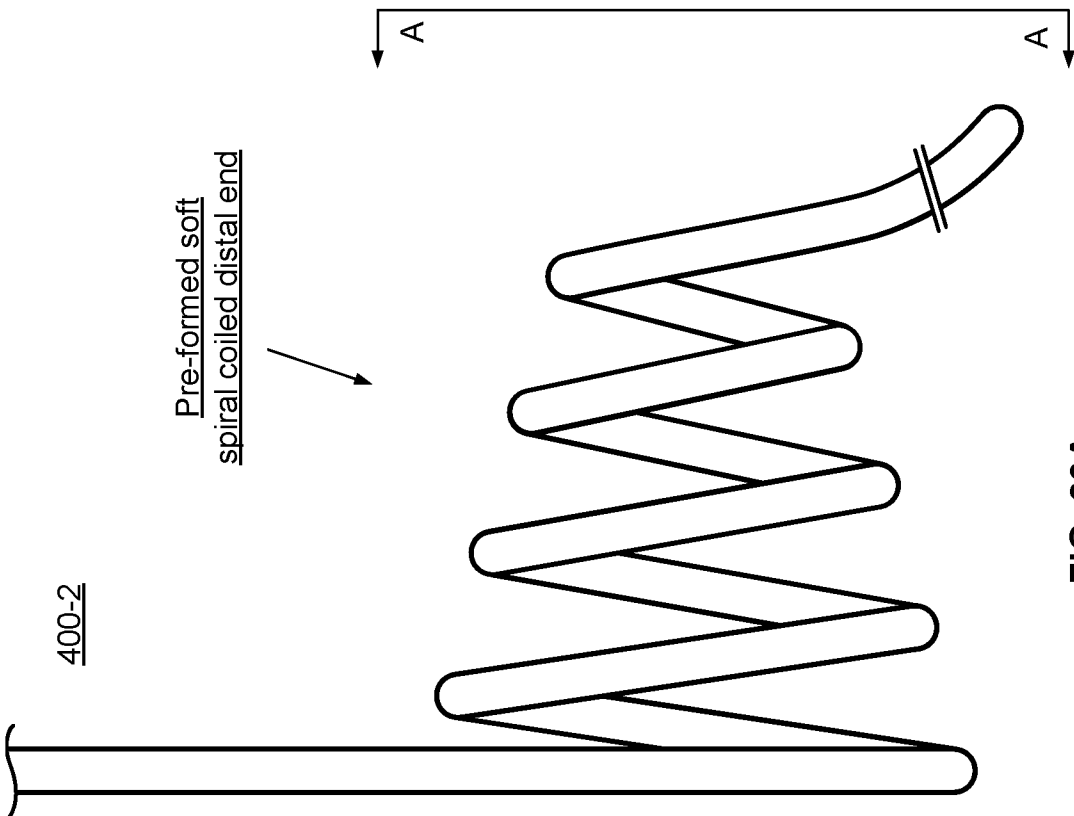
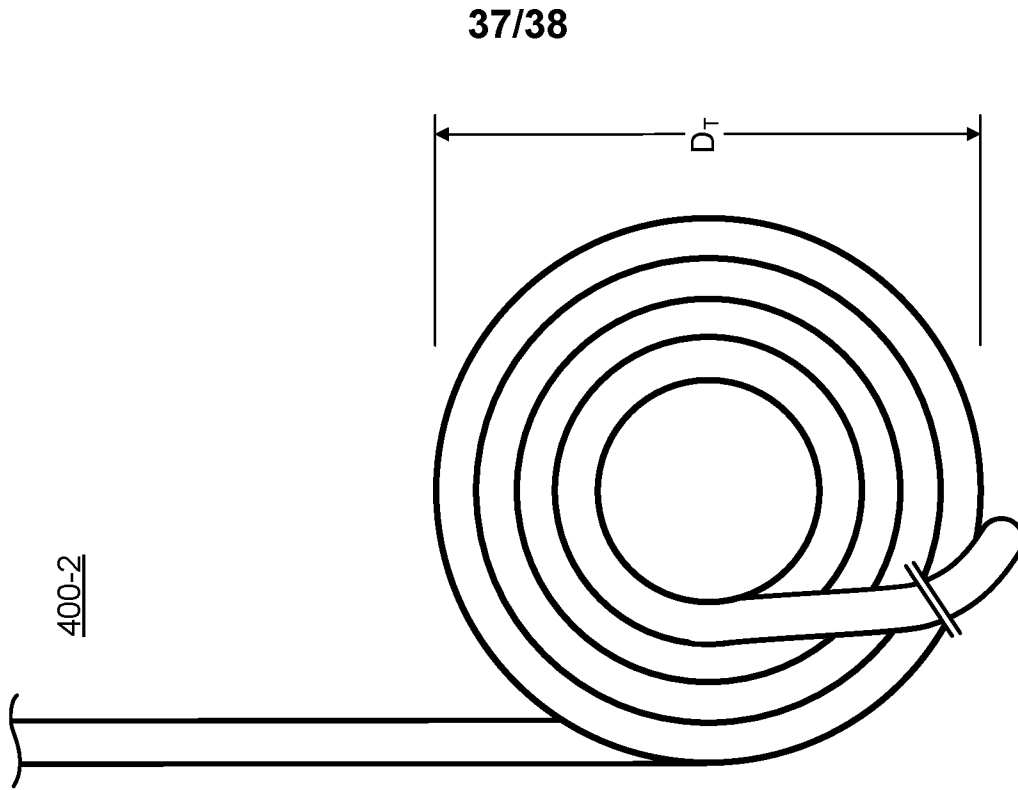

FIG. 27A



VIEW FROM A-A OF FIG. 23A



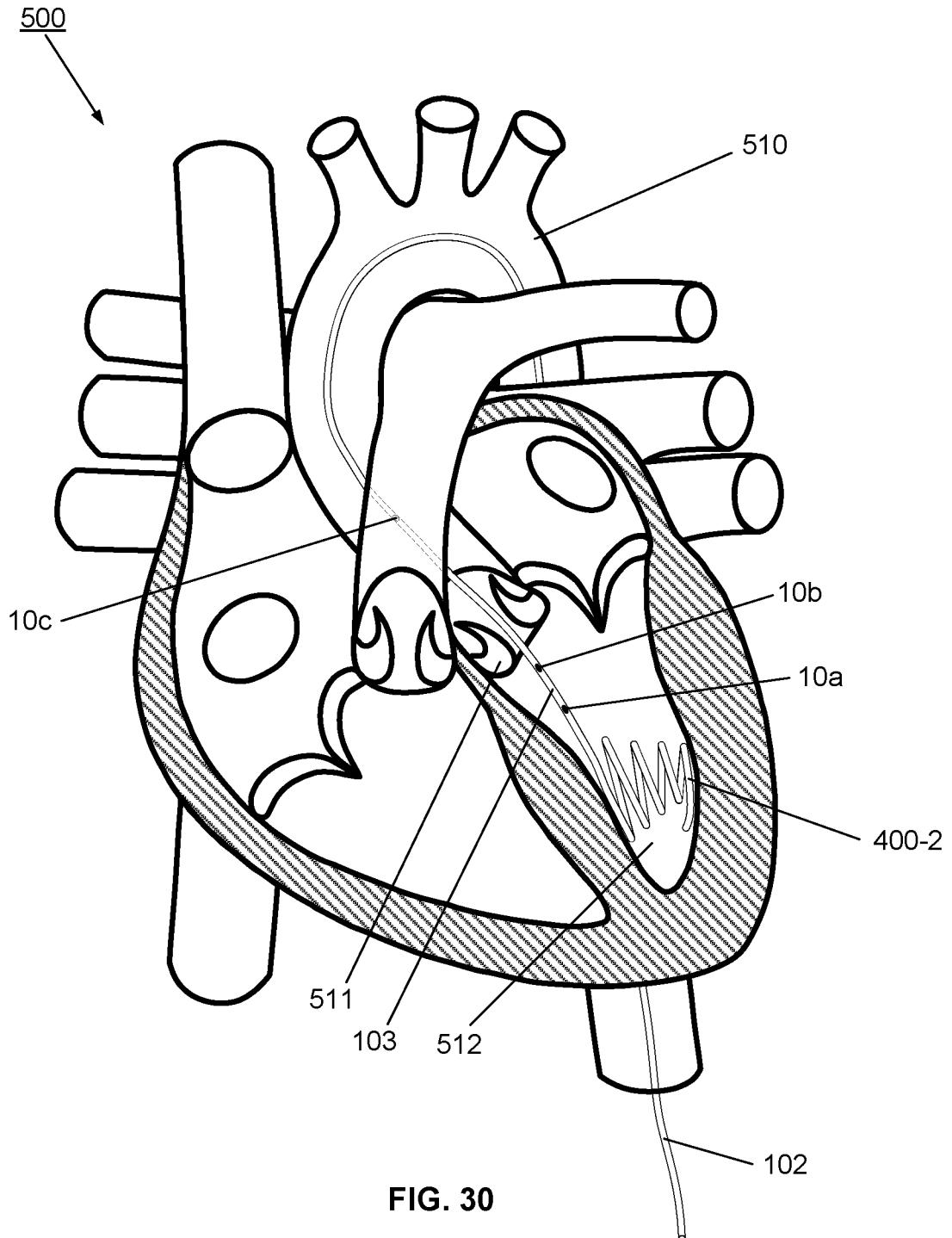

FIG. 30

INTERNATIONAL SEARCH REPORT

International application No.

PCT/IB2015/055240

A. CLASSIFICATION OF SUBJECT MATTER IPC: <i>A61B 5/00</i> (2006.01), <i>A61B 5/0205</i> (2006.01), <i>A61B 5/0215</i> (2006.01), <i>A61B 5/026</i> (2006.01), <i>A61B 5/042</i> (2006.01), <i>A61F 2/24</i> (2006.01)		
B. FIELDS SEARCHED		
Minimum documentation searched (classification system followed by classification symbols) IPC: <i>A61B 5/00</i> (2006.01), <i>A61B 5/0205</i> (2006.01), <i>A61B 5/0215</i> (2006.01), <i>A61B 5/026</i> (2006.01), <i>A61B 5/042</i> (2006.01), <i>A61F 2/24</i> (2006.01)		
Documentation searched other than minimum documentation to the extent that such documents are included in the fields searched		
Electronic database(s) consulted during the international search (name of database(s) and, where practicable, search terms used) Orbit Questel, Google Patent, Canadian Patent Database Keywords: cardiology, diagnostic, measure, sensor, fiber, guidewire, female, male, connector, heart valve		
C. DOCUMENTS CONSIDERED TO BE RELEVANT		
Category*	Citation of document, with indication, where appropriate, of the relevant passages	Relevant to claim No.
X Y	WO 2013/061281 A1 (CARON, E. et al.) 02 May 2013 (02-05-2013) See abstract; page 12, lines 11-19; claim 23; page 22, lines 14-23; page 22, lines 25-30; page 28, line 25; page 34, lines 31-33; page 11, lines 8-11; page 7, lines 14-18; page 10, lines 15-16; page 21, lines 13-21; Figure 1, 7A-7C;	46, 47 1-45, 48-53
Y	US 7532920 B1 (AINSWORTH, D. R. et al.) 12 May 2009 (12-05-2009) Col.3, lines 23-35; col.7, lines 18-32; col.5, lines 31-38; col.11, lines 9-15; col.9, lines 53-61; col.10, lines 14-23	1-45, 48-53
Y	US 2010/0228112 A1 (MALMBORG, P. V.) 09 September 2010 (09-09-2010) Paragraph 29, 30	2, 3, 5, 48-50
<input type="checkbox"/> Further documents are listed in the continuation of Box C. <input checked="" type="checkbox"/> See patent family annex.		
* "A" "E" "L" "O" "P"	Special categories of cited documents: document defining the general state of the art which is not considered to be of particular relevance earlier application or patent but published on or after the international filing date document which may throw doubts on priority claim(s) or which is cited to establish the publication date of another citation or other special reason (as specified) document referring to an oral disclosure, use, exhibition or other means document published prior to the international filing date but later than the priority date claimed	"T" later document published after the international filing date or priority date and not in conflict with the application but cited to understand the principle or theory underlying the invention "X" document of particular relevance; the claimed invention cannot be considered novel or cannot be considered to involve an inventive step when the document is taken alone "Y" document of particular relevance; the claimed invention cannot be considered to involve an inventive step when the document is combined with one or more other such documents, such combination being obvious to a person skilled in the art "&" document member of the same patent family
Date of the actual completion of the international search 24 November 2015 (24-11-2015)		Date of mailing of the international search report 26 November 2015 (26-11-2015)
Name and mailing address of the ISA/CA Canadian Intellectual Property Office Place du Portage I, C114 - 1st Floor, Box PCT 50 Victoria Street Gatineau, Quebec K1A 0C9 Facsimile No.: 001-819-953-2476		Authorized officer Li Pan (819) 639-8273

INTERNATIONAL SEARCH REPORT

International application No.

PCT/IB2015/055240**Box No. II Observations where certain claims were found unsearchable (Continuation of item 2 of the first sheet)**

This international search report has not been established in respect of certain claims under Article 17(2)(a) for the following reasons:

1. Claim Nos.:
because they relate to subject matter not required to be searched by this Authority, namely:

2. Claim Nos.:
because they relate to parts of the international application that do not comply with the prescribed requirements to such an extent that no meaningful international search can be carried out, specifically:

3. Claim Nos.:
because they are dependent claims and are not drafted in accordance with the second and third sentences of Rule 6.4(a).

Box No. III Observations where unity of invention is lacking (Continuation of item 3 of first sheet)

This International Searching Authority found multiple inventions in this international application, as follows:

Group A - Claims 1-53 are directed to a multisensor guidewire for diagnostic measurements in interventional cardiology.

Group B - Claims 54-70 are directed to a core wire for a sensor guidewire comprising an outer flexible coil wire of outside diameter of lmm or less, the core wire having a diameter Dcore to fit within the outer flexible coil wire, and the core wire having a cross-section profile defining a 10 channel means along a length of the core wire, the channel means comprising part of a surface of the core wire comprising a channel surface recessed within the diameter Dcore and extending along the length of the core wire for accommodating or more optical fibers within the diameter Dcore of the core wire.

1. As all required additional search fees were timely paid by the applicant, this international search report covers all searchable claims.
2. As all searchable claims could be searched without effort justifying additional fees, this Authority did not invite payment of additional fees.
3. As only some of the required additional search fees were timely paid by the applicant, this international search report covers only those claims for which fees were paid, specifically claim Nos.:
4. No required additional search fees were timely paid by the applicant. Consequently, this international search report is restricted to the invention first mentioned in the claims; it is covered by claim Nos.:

1-53

- Remark on Protest**
- The additional search fees were accompanied by the applicant's protest and, where applicable, the payment of a protest fee.
 - The additional search fees were accompanied by the applicant's protest but the applicable protest fee was not paid within the time limit specified in the invitation.
 - No protest accompanied the payment of additional search fees.

INTERNATIONAL SEARCH REPORT
Information on patent family members

International application No.
PCT/IB2015/055240

Patent Document Cited in Search Report	Publication Date	Patent Family Member(s)	Publication Date
WO2013061281A1	02 May 2013 (02-05-2013)	WO2013061281A1	02 May 2013 (02-05-2013)
		CA2849717A1	02 May 2013 (02-05-2013)
		CA2849717C	21 October 2014 (21-10-2014)
		CN103997954A	20 August 2014 (20-08-2014)
		EP2770904A1	03 September 2014 (03-09-2014)
		EP2770904A4	03 September 2014 (03-09-2014)
		HK1200300A1	07 August 2015 (07-08-2015)
		JP2015501184A	05 January 2015 (15-01-2015)
		US2014249386A1	04 September 2014 (04-09-2014)
		US9149230B2	06 October 2015 (06-10-2015)
		US2014243688A1	28 August 2014 (28-08-2014)
WO2013061280A1	02 May 2013 (02-05-2013)		
US7532920B1	12 May 2009 (12-05-2009)	None	
US2010228112A1	09 September 2010 (09-09-2010)	US2010228112A1	09 September 2010 (09-09-2010)
		EP2211701A1	04 August 2010 (04-08-2010)
		WO2009054802A1	30 April 2009 (30-04-2009)

专利名称(译)	系统和装置包括用于介入心脏病学多传感器导丝		
公开(公告)号	EP3166478A1	公开(公告)日	2017-05-17
申请号	EP2015821600	申请日	2015-07-10
申请(专利权)人(译)	三江心血管SYSTEMS INC.		
当前申请(专利权)人(译)	三江心血管SYSTEMS INC.		
[标]发明人	CARON ERIC BILODEAU LUC		
发明人	CARON, ERIC BILODEAU, LUC		
IPC分类号	A61B5/00 A61B5/0205 A61B5/0215 A61B5/026 A61B5/042 A61F2/24		
CPC分类号	A61B5/6851 A61B5/02154 A61B5/02158 A61B5/042 A61B2560/0462 A61B2560/066 A61B2562/228 A61F2/24 A61F2/2418 A61F2/2427		
优先权	62/023891 2014-07-13 US 62/039952 2014-08-21 US		
其他公开文献	EP3166478A4		
外部链接	Espacenet		

摘要(译)

包括用于介入心脏病学多传感器导丝 (100/200/300) 的系统 (1) 和装置, 例如经导管瓣膜疗法 (TVT), 包括用于直接测量心血管参数的多个光学传感器 (10/20) 。 , 例如跨瓣血压梯度和血流量。传统的外线圈线 (35) 包含成形的芯线 (31), 该芯线具有限定通道表面 (132) 的横截面, 例如通道表面 (132) 。沿其长度延伸的凹槽 (32) 将光纤 (11) 和光学传感器 (10/20) 定位在通道 (33) 中。有利地, 芯线的直径为导丝提供足够的刚度, 以用作TVT的支撑导丝, 例如, 用于TVT的导线。经导管主动脉瓣植入术 (TAVI), 同时在外径 $\leq 0.89\text{mm}$ 的导丝内容纳多个传感器和纤维。光学连接器 (112) 将导丝连接到控制系统 (150) 。可选地, 导丝包括接触力传感器 (60), 预成形尖端 (400-1 / 400-2) 和可分离微连接器 (140) 。