



- (51) International Patent Classification:
G11C 16/06 (2006.01) *G11C 27/00* (2006.01)
G11C 16/00 (2006.01)
- (21) International Application Number:
 PCT/IB2014/064319
- (22) International Filing Date:
 8 September 2014 (08.09.2014)
- (25) Filing Language:
 English
- (26) Publication Language:
 English
- (30) Priority Data:
 61/875,070 8 September 2013 (08.09.2013) US
 61/875,069 8 September 2013 (08.09.2013) US
 61/875,074 8 September 2013 (08.09.2013) US
 61/925,670 10 January 2014 (10.01.2014) US
 61/925,669 10 January 2014 (10.01.2014) US
 PCT/IL2014/050086
 24 January 2014 (24.01.2014) IL
 PCT/IL2014/050088
 24 January 2014 (24.01.2014) IL
 PCT/IL2014/050089
 24 January 2014 (24.01.2014) IL

- PCT/IL2014/050090
 24 January 2014 (24.01.2014) IL
- PCT/IL2014/050246 11 March 2014 (11.03.2014) IL
- 62/003,108 27 May 2014 (27.05.2014) US
- 62/030,740 30 July 2014 (30.07.2014) US
- 62/030,972 30 July 2014 (30.07.2014) US
- 62/030,917 30 July 2014 (30.07.2014) US

(72) Inventor; and
 (71) Applicant : **BEN-HAIM, Shlomo** [IL/GB]; c/o Lemuria Alliance SA, 17 Rue des Pierres-du-Niton, CH-1207 Geneva (CH).

(81) Designated States (unless otherwise indicated, for every kind of national protection available): AE, AG, AL, AM, AO, AT, AU, AZ, BA, BB, BG, BH, BN, BR, BW, BY, BZ, CA, CH, CL, CN, CO, CR, CU, CZ, DE, DK, DM, DO, DZ, EC, EE, EG, ES, FI, GB, GD, GE, GH, GM, GT, HN, HR, HU, ID, IL, IN, IR, IS, JP, KE, KG, KN, KP, KR, KZ, LA, LC, LK, LR, LS, LU, LY, MA, MD, ME, MG, MK, MN, MW, MX, MY, MZ, NA, NG, NI, NO, NZ, OM, PA, PE, PG, PH, PL, PT, QA, RO, RS, RU, RW, SA, SC, SD, SE, SG, SK, SL, SM, ST, SV, SY, TH, TJ, TM, TN, TR, TT, TZ, UA, UG, US, UZ, VC, VN, ZA, ZM, ZW.

[Continued on next page]

(54) Title: APPARATUS AND METHODS FOR DIAGNOSIS AND TREATMENT OF PATTERNS OF NERVOUS SYSTEM ACTIVITY AFFECTING DISEASE

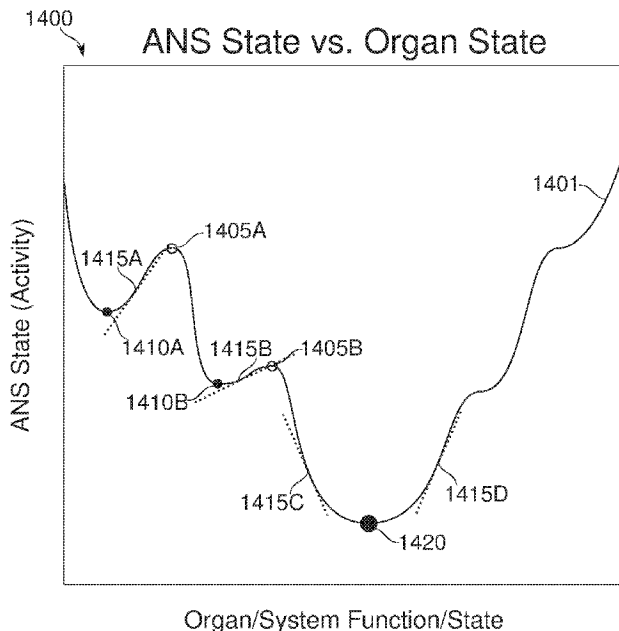

FIG. 14

(57) Abstract: A method for diagnosing and/or treating a medical condition, comprising modeling an activity of the autonomic nervous system, and treating the medical condition by guiding a therapeutic agent according to the model.

WO 2015/033319 A2

(84) Designated States (*unless otherwise indicated, for every kind of regional protection available*): ARIPO (BW, GH, GM, KE, LR, LS, MW, MZ, NA, RW, SD, SL, ST, SZ, TZ, UG, ZM, ZW), Eurasian (AM, AZ, BY, KG, KZ, RU, TJ, TM), European (AL, AT, BE, BG, CH, CY, CZ, DE, DK, EE, ES, FI, FR, GB, GR, HR, HU, IE, IS, IT, LT, LU, LV, MC, MK, MT, NL, NO, PL, PT, RO, RS, SE, SI, SK, SM, TR), OAPI (BF, BJ, CF, CG, CI, CM, GA, GN, GQ, GW, KM, ML, MR, NE, SN, TD, TG).

Declarations under Rule 4.17:

— *of inventorship (Rule 4.17(iv))*

Published:

— *without international search report and to be republished upon receipt of that report (Rule 48.2(g))*

APPARATUS AND METHODS FOR DIAGNOSIS AND TREATMENT OF
PATTERNS OF NERVOUS SYSTEM ACTIVITY AFFECTING DISEASE

RELATED APPLICATIONS

5 This application claims the benefit of priority under 35 USC §119(e) of:
U.S. Provisional Patent Application No. 61/875,069 filed September 8, 2013,
U.S. Provisional Patent Application No. 61/875,070 filed September 8, 2013,
U.S. Provisional Patent Application No. 61/875,074 filed September 8, 2013,
U.S. Provisional Patent Application No. 61/925,670 filed January 10, 2014,
10 U.S. Provisional Patent Application No. 61/925,669 filed January 10, 2014,
U.S. Provisional Patent Application No. 62/003,108 filed May 27, 2014,
U.S. Provisional Patent Application No. 62/030,740 filed July 30, 2014,
U.S. Provisional Patent Application No. 62/030,972 filed July 30, 2014, and
U.S. Provisional Patent Application No. 62/030,917 filed July 30, 2014.

15 This application claims the benefit of priority under 35 USC §120 of:
PCT Patent Application No. PCT/IL2014/050086 filed January 24, 2014,
PCT Patent Application No. PCT/IL2014/050088 filed January 24, 2014,
PCT Patent Application No. PCT/IL2014/050089 filed January 24, 2014,
PCT Patent Application No. PCT/IL2014/050090 filed January 24, 2014, and
20 PCT Patent Application No. PCT/IL2014/050246 filed March 11, 2014.

The contents of the above applications are incorporated by reference as if fully set forth herein in their entirety.

FIELD AND BACKGROUND OF THE INVENTION

25 The present invention, in some embodiments thereof, relates to means and/or methods for diagnosing and/or treating disease using patterns of nervous system activity, and, more particularly, but not exclusively, to such means and methods in relation to diseases affecting and/or involving the autonomic nervous system.

30 SUMMARY OF THE INVENTION

According to an aspect of some embodiments of the present invention, there is provided a method of treating a medical condition comprising: determining a pattern of

autonomic innervation activity associated with a physiological parameter affecting the medical condition; matching the determined pattern to a modeled pattern; selecting an adjustment of the modeled pattern; and guiding a therapeutic agent to adjust the determined pattern in correspondence with the adjustment of the modeled pattern,
5 thereby treating the medical condition.

According to some embodiments of the invention, the adjustment of the determined pattern adjusts autonomic control of the physiological parameter from a first mode of modulation to a second mode of modulation.

10 According to some embodiments of the invention, a difference between the first and second modes comprises a different homeostatic set point of the physiological parameter.

According to some embodiments of the invention, a difference between the first and second modes comprises a different range of available values for the physiological parameter.

15 According to some embodiments of the invention, the adjustment of the modeled pattern is associated with a mode of autonomic modulation of the physiological parameter.

According to some embodiments of the invention, the second mode of modulation corresponds to the associated mode.

20 According to some embodiments of the invention, the determined pattern comprises activity measured for a plurality of ANS locations.

According to some embodiments of the invention, the determined pattern comprises activity measured in at least one ANS location for a plurality of physiological states.

25 According to some embodiments of the invention, the guiding comprises administering the therapeutic agent to an ANS location within the determined pattern, the location being chosen for its correspondence to the selected adjustment.

According to some embodiments of the invention, the guiding comprises administering the therapeutic agent at a time selected for its correspondence to the
30 selected adjustment.

According to some embodiments of the invention, the guiding comprises administering the therapeutic agent at a dosage chosen for its correspondence to the selected adjustment.

5 According to some embodiments of the invention, the second mode of modulation comprises modulation of the physiological parameter away from a physiological norm, relative to the first mode of modulation.

According to some embodiments of the invention, adjusting the determined pattern adjusts modulation of the physiological parameter to reduce a vulnerability to control feedback leading to a progression of the medical condition.

10 According to some embodiments of the invention, adjusting the determined pattern adjusts the sensitivity of a first non-neural system organ to signaling from a second non-neural system organ.

According to some embodiments of the invention, adjusting the determined pattern affects resizing of the cellular bulk of an organ.

15 According to some embodiments of the invention, adjusting the determined pattern comprises reducing ANS activity.

According to some embodiments of the invention, adjusting the determined pattern comprises increasing ANS activity.

20 According to some embodiments of the invention, the matching comprises matching ANS neural function activity levels within anatomically defined boundaries.

According to some embodiments of the invention, the adjusting comprises balancing ANS neural function activity levels among a plurality of organ regions.

According to some embodiments of the invention, at least two of the plurality of organ regions are part of a single organ.

25 According to some embodiments of the invention, at least two of the plurality of organ regions are part of separate organs.

According to some embodiments of the invention, the determining itself comprises: stimulating to elicit activity in ANS locations; and defining positions involved in the pattern of autonomic innervation activity, based on the positions of the ANS locations.

30

According to some embodiments of the invention, the stimulating comprises administering an electrical or electromagnetic pulse.

According to some embodiments of the invention, the stimulating comprises manipulating a physiological state.

According to some embodiments of the invention, the matching comprises applying an analysis template configured to transform the pattern according to characteristics relevant to the disease.

According to some embodiments of the invention, the configuration of the analysis template defines a normalization.

According to some embodiments of the invention, the configuration of the analysis template defines a mask.

According to an aspect of some embodiments of the present invention, there is provided a method comprising: measuring autonomic innervation activity associated with a medical condition; and applying the results of the measurement to the medical condition.

According to some embodiments of the invention, the measuring comprises determining the distribution of a tracer.

According to some embodiments of the invention, the tracer is radioactive, and the determining comprises nuclear imaging.

According to some embodiments of the invention, the medical condition is selected from among the group comprising: diabetes, benign prostate hyperplasia, erectile dysfunction, rheumatoid arthritis, and irritable bowel syndrome.

According to some embodiments of the invention, the medical condition is selected from among the group comprising: syncope, hypothyroidism, idiopathic heart failure, asthma, deposition disease, IBS, and weight gain.

According to some embodiments of the invention, the medical condition is selected from among the group comprising: hyperhidrosis hypertrophic cardiomyopathy obesity, chronic obstructive pulmonary disease, thyrotoxicosis, and hypertension.

According to some embodiments of the invention, the medical condition is selected from among the group comprising: torticollis, idiopathic dilated cardiomyopathy, right ventricular outflow tachycardia, Brugada syndrome, tetralogy of Fallot, deposition disease of the lungs, sleep apnea asthma metabolic liver disease compromised salivation control, and compromised lacrimation control.

According to some embodiments of the invention, the applying comprises at least one of the group consisting of: analyzing the measurement for a pattern of activity relating to the medical condition, associating a pattern of activity to a treatment for the medical condition, mapping the pattern of activity to one or more organs affecting the
5 medical condition, interpreting the measurement as indicating a particular aspect of the medical condition, reading the measurement as a description of the medical condition, and examining the measurement for a finding about the medical condition.

According to some embodiments of the invention, the autonomic innervation activity is measured from a plurality of ANS locations.

10 According to some embodiments of the invention, the plurality of ANS locations comprise different regions of the same organ.

According to some embodiments of the invention, the plurality of ANS locations comprises regions of different organs.

15 According to some embodiments of the invention, at least one of the plurality of ANS locations comprises a ganglion providing autonomic innervation to another of the plurality of ANS locations.

According to some embodiments of the invention, at least one of the ANS locations comprises sympathetic innervation, and at least one of the ANS locations comprises parasympathetic innervation.

20 According to an aspect of some embodiments of the present invention, there is provided a system comprising: a modeling unit, configured to receive measurements of ANS activity, and determine therefrom a model describing ANS activity relevant to an organ system affected by a medical condition; a model manipulation unit, configured to apply the model to highlight a feature of the medical condition.

25 According to some embodiments of the invention, the medical condition is selected from among the group comprising: diabetes, benign prostate hyperplasia, erectile dysfunction, rheumatoid arthritis, and irritable bowel syndrome.

30 According to some embodiments of the invention, the medical condition is selected from among the group comprising: hyperhidrosis hypertrophic cardiomyopathy obesity, chronic obstructive pulmonary disease, thyrotoxicosis, and hypertension.

According to some embodiments of the invention, the medical condition is selected from among the group comprising: syncope, hypothyroidism, idiopathic heart failure, asthma, deposition disease, IBS, and weight gain.

5 According to some embodiments of the invention, the medical condition is selected from among the group comprising: torticollis, idiopathic dilated cardiomyopathy, right ventricular outflow tachycardia, Brugada syndrome, tetralogy of Fallot, deposition disease of the lungs, sleep apnea asthma metabolic liver disease compromised salivation control, and compromised lacrimation control.

10 According to some embodiments of the invention, the applying comprises at least one of the group consisting of: analyzing the measurement for a pattern of activity relating to the medical condition, the feature being the pattern of activity; associating a pattern of activity to a treatment for the medical condition, the feature being the association; mapping the pattern of activity to one or more organs affecting the medical condition, the feature being the map of activity to anatomy generated thereby;
15 interpreting the measurement as indicating a particular aspect of the medical condition, the feature being the particular aspect; reading the measurement as a description of the medical condition, the feature being the description; and examining the measurement for a finding about the medical condition, the feature being the finding.

20 According to an aspect of some embodiments of the present invention, there is provided a method comprising: modeling an activity of the autonomic nervous system; treating a medical condition by guiding a therapeutic agent according to the modeling.

25 According to some embodiments of the invention, the method comprises detecting the medical condition according to the modeling. According to some embodiments of the invention, the medical condition is associated with the autonomic nervous system. According to some embodiments of the invention, the medical condition is associated with hyperactivity of the ANS. According to some embodiments of the invention, the medical condition is associated with hypoactivity of the ANS. According to some embodiments of the invention, the guiding comprises navigating the therapeutic agent according to mapping of a neurotransmitter marker. According to
30 some embodiments of the invention, the modeling comprises imaging one or more organs by using a radiopharmaceutical. According to some embodiments of the invention, the medical condition is one of diabetes, irritable bowel syndrome,

hypertension, cardiomyopathy, rheumatoid arthritis, prostatic hyperplasia. According to some embodiments of the invention, the method comprises estimating a level of activity of an organ or a portion of an organ. According to some embodiments of the invention, the level is an absolute level. According to some embodiments of the invention, the method comprises comparing the level to an activity level of another organ. According to some embodiments of the invention, the method comprises estimating a response to ANS activity. According to some embodiments of the invention, the method comprises assessing a stage of the medical condition according to the modeling. According to some embodiments of the invention, the method comprises monitoring treatment according to the modeling. According to some embodiments of the invention, the treating comprises ablating one or more components of the ANS.

According to an aspect of some embodiments of the present invention, there is provided an apparatus for modeling a nervous system, comprising an imager; and a software configured for analyzing an activity of the nervous system and for modeling the activity using an image acquired by the imager.

According to some embodiments of the invention, the imager is a SPECT camera.

According to an aspect of some embodiments of the present invention, there is provided a method of characterizing dysfunctional homeostasis, comprising: receiving autonomic nervous system activity data, and measurements of at least one other physiological parameter related to a homeostatic system; analyzing a variation relationship between the activity data and the measurements; and producing, based on the analyzing, a characterizing description of autonomic nervous system activity, associated with an aspect of dysfunction of the homeostatic system.

According to some embodiments of the invention, the characterizing description comprises described locations of autonomic nervous system loci involved in the dysfunction.

According to some embodiments of the invention, the method comprises using the characterizing description to diagnose the role of autonomic nervous system members and/or organs on generation or sustainment of disease.

According to some embodiments of the invention, the method comprises using the characterizing description to select a tissue target for intervention, for treating a disease related to the homeostatic dysfunction.

5 According to some embodiments of the invention, the method comprises guiding an agent to modulate activity of the selected tissue target related to the homeostatic system.

According to some embodiments of the invention, the characterizing description identifies an attractor range in the analyzed variation relationship between the activity data and the measurements.

10 According to some embodiments of the invention, the characterizing description identifies a repeller range in the analyzed variation relationship between the activity data and the measurements.

According to some embodiments of the invention, the method comprises classification of the characterizing description to a pattern associated with a treatment of a disease involving the dysfunctional homeostasis.

According to some embodiments of the invention, the method comprises classification of the characterizing description to a pattern associated with a particular disease state.

20 According to some embodiments of the invention, the autonomic nervous system activity data comprise data taken over a range comprising at least two different activity levels.

According to some embodiments of the invention, the measurements of the at least one other physiological parameter are taken over a range comprising at least two different levels of the physiological parameter.

25 According to some embodiments of the invention, the at least two different levels of the physiological parameter comprise a level associated with a healthy state, and a level associated with a pathological state.

30 According to an aspect of some embodiments of the present invention, there is provided an autonomic nervous system disease decoding (ADD) system for characterizing a pathological condition, comprising a mapping module, configured to: receive and autonomic nervous system activity data and physiological parameter

measurements, and map a variation relationship between the activity data and the measurements to produce a control graph.

According to some embodiments of the invention, the ADD system comprises a feature detection module, configured to: classify regions of the control graph, and
5 produce a characterization of autonomic nervous system activity associated with a dysfunction of the homeostatic system expressed terms of the classified regions.

According to some embodiments of the invention, the characterization comprises described locations of autonomic nervous system loci involved in the dysfunction.

10 According to some embodiments of the invention, the ADD system comprises a diagnosis module, configured to use the characterization to diagnose the role of autonomic nervous system members and/or organs on generation or sustainment of disease.

According to some embodiments of the invention, the ADD system comprises a
15 treatment planning module, configured to uses the characterization to select a tissue target for intervention, for treating a disease related to the homeostatic dysfunction.

Unless otherwise defined, all technical and/or scientific terms used herein have the same meaning as commonly understood by one of ordinary skill in the art to which the invention pertains. Although methods and materials similar or equivalent to those
20 described herein can be used in the practice or testing of embodiments of the invention, exemplary methods and/or materials are described below. In case of conflict, the patent specification, including definitions, will control. In addition, the materials, methods, and examples are illustrative only and are not intended to be necessarily limiting.

As will be appreciated by one skilled in the art, aspects of the present invention
25 may be embodied as a system, method or computer program product. Accordingly, aspects of the present invention may take the form of an entirely hardware embodiment, an entirely software embodiment (including firmware, resident software, micro-code, etc.) or an embodiment combining software and hardware aspects that may all generally be referred to herein as a "circuit," "module" or "system." Furthermore, aspects of the
30 present invention may take the form of a computer program product embodied in one or more computer readable medium(s) having computer readable program code embodied thereon. Implementation of the method and/or system of embodiments of the invention

can involve performing or completing selected tasks manually, automatically, or a combination thereof.

For example, hardware for performing selected tasks according to embodiments of the invention could be implemented as a chip or a circuit. As software, selected tasks
5 according to embodiments of the invention could be implemented as a plurality of software instructions being executed by a computer using any suitable operating system. In an exemplary embodiment of the invention, one or more tasks according to exemplary embodiments of method and/or system as described herein are performed by a data processor, such as a computing platform for executing a plurality of instructions.
10 Optionally, the data processor includes a volatile memory for storing instructions and/or data and/or a non-volatile storage, for example, a magnetic hard-disk and/or removable media, for storing instructions and/or data. Optionally, a network connection is provided as well. A display and/or a user input device such as a keyboard or mouse are optionally provided as well.

15 Any combination of one or more computer readable medium(s) may be utilized. The computer readable medium may be a computer readable signal medium or a computer readable storage medium. A computer readable storage medium may be, for example, but not limited to, an electronic, magnetic, optical, electromagnetic, infrared, or semiconductor system, apparatus, or device, or any suitable combination of the
20 foregoing. More specific examples (a non-exhaustive list) of the computer readable storage medium would include the following: an electrical connection having one or more wires, a portable computer diskette, a hard disk, a random access memory (RAM), a read-only memory (ROM), an erasable programmable read-only memory (EPROM or Flash memory), an optical fiber, a portable compact disc read-only memory (CD-ROM),
25 an optical storage device, a magnetic storage device, or any suitable combination of the foregoing. In the context of this document, a computer readable storage medium may be any tangible medium that can contain, or store a program for use by or in connection with an instruction execution system, apparatus, or device.

A computer readable signal medium may include a propagated data signal with
30 computer readable program code embodied therein, for example, in baseband or as part of a carrier wave. Such a propagated signal may take any of a variety of forms, including, but not limited to, electro-magnetic, optical, or any suitable combination

thereof. A computer readable signal medium may be any computer readable medium that is not a computer readable storage medium and that can communicate, propagate, or transport a program for use by or in connection with an instruction execution system, apparatus, or device.

5 Program code embodied on a computer readable medium may be transmitted using any appropriate medium, including but not limited to wireless, wireline, optical fiber cable, RF, etc., or any suitable combination of the foregoing.

 Computer program code for carrying out operations for aspects of the present invention may be written in any combination of one or more programming languages, including an object oriented programming language such as Java, Smalltalk, C++ or the like and conventional procedural programming languages, such as the "C" programming language or similar programming languages. The program code may execute entirely on the user's computer, partly on the user's computer, as a stand-alone software package, partly on the user's computer and partly on a remote computer or entirely on the remote computer or server. In the latter scenario, the remote computer may be connected to the user's computer through any type of network, including a local area network (LAN) or a wide area network (WAN), or the connection may be made to an external computer (for example, through the Internet using an Internet Service Provider).

 Aspects of the present invention are described below with reference to flowchart illustrations and/or block diagrams of methods, apparatus (systems) and computer program products according to embodiments of the invention. It will be understood that each block of the flowchart illustrations and/or block diagrams, and combinations of blocks in the flowchart illustrations and/or block diagrams, can be implemented by computer program instructions. These computer program instructions may be provided to a processor of a general purpose computer, special purpose computer, or other programmable data processing apparatus to produce a machine, such that the instructions, which execute via the processor of the computer or other programmable data processing apparatus, create means for implementing the functions/acts specified in the flowchart and/or block diagram block or blocks.

30 These computer program instructions may also be stored in a computer readable medium that can direct a computer, other programmable data processing apparatus, or other devices to function in a particular manner, such that the instructions stored in the

computer readable medium produce an article of manufacture including instructions which implement the function/act specified in the flowchart and/or block diagram block or blocks.

The computer program instructions may also be loaded onto a computer, other
5 programmable data processing apparatus, or other devices to cause a series of operational steps to be performed on the computer, other programmable apparatus or other devices to produce a computer implemented process such that the instructions which execute on the computer or other programmable apparatus provide processes for implementing the functions/acts specified in the flowchart and/or block diagram block
10 or blocks.

BRIEF DESCRIPTION OF THE DRAWINGS

Some embodiments of the invention are herein described, by way of example only, with reference to the accompanying drawings. With specific reference now to the
15 drawings in detail, it is stressed that the particulars shown are by way of example, and for purposes of illustrative discussion of embodiments of the invention. In this regard, the description taken with the drawings makes apparent to those skilled in the art how embodiments of the invention may be practiced.

In the drawings:

20 FIG. 1 schematically shows a method of using a map of autonomic nervous system activity in the evaluation and/or therapeutic treatment of benign prostatic hyperplasia, according to some exemplary embodiments of the invention;

FIG. 2 schematically shows a method of using a map of autonomic nervous system activity in the evaluation and/or therapeutic treatment of an erectile function
25 disorder, according to some exemplary embodiments of the invention;

FIG. 3 schematically shows a method of using a map of autonomic nervous system activity in the evaluation and/or therapeutic treatment of diabetes, according to some exemplary embodiments of the invention;

30 FIG. 4 schematically shows a method of using a map of autonomic nervous system activity in the evaluation and/or therapeutic treatment of rheumatoid arthritis, according to some exemplary embodiments of the invention;

FIG. 5 schematically shows a method of using a map of autonomic nervous system activity in the evaluation and/or therapeutic treatment of irritable bowel syndrome, according to some exemplary embodiments of the invention;

FIG. 6 comprises an ANSmap image for a patient with sigmoid septum and cardiomyopathy, according to some exemplary embodiments of the invention;

FIG. 7 illustrates an exemplary deposition pathway, according to some exemplary embodiments of the invention;

FIG. 8 is a flow chart of a method for processing functional images to identify and/or locate one or more ANS components (such as ganglia), according to some exemplary embodiments of the invention;

FIG. 9 is a block diagram of a model ANS modeling and/or pattern evaluation system/unit, in accordance with some exemplary embodiments of the invention;

FIG. 10 is a block diagram of a model and/or pattern analysis and treatment planning system/unit, in accordance with some exemplary embodiments of the invention;

FIG. 11 is a schematic diagram of an autonomic nervous system, to help understand some embodiments of the present invention.

FIG. 12 is a schematic flowchart showing the operation of an ANS-disease decoder (ADD), according to some exemplary embodiments of the invention;

FIG. 13 is a schematic flowchart of an initial phase of analysis performed by an ADD unit, according to some exemplary embodiments of the invention;

FIG. 14 is a schematic graph of a mapping between organ/system function and/or state, according to some exemplary embodiments of the invention;

FIG. 15 schematically illustrates a diagnostic measurement configuration, allowing measurements of a physiological parameter's changes in response to manipulation, together with measurements of ANS activity, for use in diagnosis and/or treatment determination, according to some exemplary embodiments of the invention;

FIG. 16 is a partial schematic flowchart of operations performed by an ADD to convert received function data into determination of an intervention, according to some exemplary embodiments of the invention; and

FIG. 17 is a schematic flowchart describing the ADD-moderated determination of application of treatment to ANS GP targeted for treatment, according to some exemplary embodiments of the invention.

5 DESCRIPTION OF SPECIFIC EMBODIMENTS OF THE INVENTION

The present invention, in some embodiments thereof, relates to means and/or methods for diagnosing and/or treating disease using patterns of nervous system activity, and, more particularly, but not exclusively, to such means and methods in relation to diseases affecting and/or involving the autonomic nervous system.

10 **Overview**

An aspect of some embodiments of the present invention relates to a method for diagnosing and/or treating disease comprising acquiring information relating to activity of the nervous system. Activity of the nervous system is determined, for example, by relating uptake of a radiolabeled neurotransmitter or neurotransmitter analog to a
15 location, condition and/or time of update.

In some embodiments, the method comprises co-registering the detected activity with a treatment agent. In some embodiments, the method comprises treating a disease using the road map guidance.

Almost every organ and tissue of the human body is under at least partial ANS
20 control. ANS control is sets the moment-to-moment functional state of organ functions. The liver, for instance, has multiple metabolic functions under ANS control.

In an example, gluconeogenesis occurs under conditions set by ANS control. For example, by increased sympathetic or decreased parasympathetic tone, the ANS induces accelerated gluconeogenesis so that the blood sugar rises. By a change in operating
25 mode, the ANS can alter the sympathetic/parasympathetic balance to stop gluconeogenesis and induce the opposite metabolic pathway—glycogenesis (which will drive a reduction in blood sugar and the building of glycogen storage in the liver). In some cases of disease—involving for example, the liver or the ANS controlling the liver—partial liver ANS denervation potentially leads to liver zones under conflicting
30 control: one trying to increase blood sugar and the other trying to reduce blood sugar. Additionally or alternatively, mismatching can be among organs within an organ system, for example between a denervated liver and a still-innervated pancreas. Herein,

where general reference is made to an organ or an organ system, it is to be understood that the reference potentially includes tissues, cells and/or cellular activity which are associated to a common cooperative function; for example, the homeostatic maintenance and/or control of a physiological parameter (a “homeostatic parameter”).

5 Such functional association allows an “organ” to be said to exist, even where common association to a (optionally physical) structural unit is absent and/or unclear. For example, cells of the immune system are considered as an “organ” in some embodiments of the invention—even though they are distributed throughout the body—in virtue of their common function. The parasympathetic, sympathetic, and other

10 nervous subsystems also constitute relatively distributed systems in this sense. In some cases, the word “system”, particularly in a phrase such as “organ system”, and/or the expression “organ/system” is used as a reminder that the subject matter described includes and/or potentially includes one or more structurally-defined organs and/or tissues, cells, and/or cellular activities which are functionally associated, even though

15 they are physically distributed. It should be understood that the term “organ/system” does not exclude cases where an organ is part of a system, or a system contained within an organ. The phrase “system component” is also used to denote tissue, cells, and/or cellular activity selected as having a common basis of operation with respect to some function (for example, cells being secretory of a particular hormone, containing cells

20 with a particular immunity function, belonging to the sympathetic or parasympathetic nervous systems, or having another function which represents a physiological commonality for regulation and control).

Some embodiments of the invention comprise means and/or methods of identifying disease states caused by interactions among innervated and denervated tissue

25 of an organ/system. In some embodiments, the identified disease state relates to a difference in sensitivity and/or responsiveness to innervation, or another change which comprises a different system response by and/or in reaction to structures and/or activity of the ANS. A potential result of such interactions is a dynamic steady state with an operating point (set point) that is neither the one driven by the ANS effect on the

30 innervated tissue nor the operating point that is created when the ANS is disconnected from the organ/system. Alternatively, conflicting subsystems created by differential denervation and/or stimulation increase prevent a steady state from being reached.

Alternatively, two or more stable points are created. Potentially, switching between stable points occurs as a result of changing conditions, with at least one of the stable points comprising a symptomatic or organ-damaging state of disease.

In some embodiments, identification comprises production of a description
5 characterizing the relationship of ANS activity (described, for example, in terms of magnitude, location and/or latency) to a physiological parameter related to a homeostatic system (for example, the homeostatic parameter itself, or a proxy parameter, such as a level of activity of an organ having a known relationship to a homeostatic parameter). Herein, homeostasis, even when described in relation to a
10 “point” or other compact region of a control map, should also be understood in relation to a more generalized concept of a homeostatic “attractor” region. For example, when there are multiple physiological parameters (N, for example) impinging on the feed-back regulation of a particular parameter's level, the region of stability is potentially extended through an at least relatively flat “surface” of the N-dimensional
15 space. Additionally or alternatively, a parameter's set point can oscillate, or “orbit”. For example a diurnally varying parameter (for example, any parameter that changes in relation to the sleep-wake cycle) can change set point normally throughout the day. In such a case, a divergence from the normal pattern of variation is what potentially comprises an observation of a disturbance relating to disease. Optionally, a disturbance
20 comprises limiting of the normal range of variation to a subrange, which, though normal in itself, comprises an abnormality when over-maintained. Optionally, a disturbance comprises an otherwise normal range of activity being entered without an appropriate forcing being present—for example, a rise in heart rate during resting, which is above normal resting level, but within normal activity levels.

25 The degree and nature of homeostasis disturbance upon denervation (or other disease process) is potentially a function of the degree of non-homogeneity introduced to the system, the level of ANS activation, and/or the level of other homeostatic mechanisms present in the organ/system to counter the effect of the unbalanced (“broken”) innervation or innervation target. Disturbance of homeostasis maintained by
30 the ANS is potentially the result of a process other than denervation (such as nerve proliferation, alternation in the health of an innervated target, loss of a sensitivity, or another reason). Examples of organ and system states described herein provide

exemplary instances where homeostasis is changed from a condition of normal functioning into a functional state which describable as disturbed (not operating normally), vulnerable to disturbance (possibly operating normally, but easily disturbed), deranged (not operating within normal parameters), dysfunctional (disturbed, vulnerable to disturbance, and/or deranged), and/or pathological (having dysfunction which presents as disease).

In some embodiments, tissues (for example, organs, cell types, and/or cells associated by a functional commonality) involved in the maintenance of a particular physiological parameter are treated as a homeostatic system. A homeostatic system particularly comprises those tissues which operate to control a net effect of their own and/or each other's activity toward an equilibrium point, upon the activity being disturbed away from that equilibrium point. The equilibrated parameter of the activity comprises, for example, a rate of production, a concentration, a level of activity, and/or a coordination among any of these. In general, the equilibrated parameter is one that can be said to assume values which are "more" or "less" than some intermediate value, towards which the homeostatic system tends to drive it.

Other concepts useful in the description of homeostatic disturbances include the notions of "attractors" and "repellers". These concepts are applicable, for example, to the analysis of a control graph characterizing the homeostatic behavior of a system of the body. A control graph is a kind of map, describing how two or more variable relate to one another in their direct or indirect effects on each other's magnitude. In some embodiments, a control graph is constructed on the basis of observed correlations and/or co-variations, with the causal relationship itself being known or specified beforehand. In some embodiments, observation of co-variation is treated as *prima facie* evidence for a causal relationship. A "repeller" exists where there is a region of the control graph that the system tends to move away from, due to a feed-forward effect: for example, a change in a first parameter leads to a change in a second—which in turn leads to additional change in the first parameter, continuing in the same direction. An "attractor" exists where there is a region of the control graph that the system tends to move toward, due to a feedback effect: for example, a change in a first parameter leads to a change in a second—which in turn tends to counteract the change in the first parameter, tending thus to a reversal of the change. In general, the same change behavior can be

equivalently be said to be “toward” an attractor, or “away” from a repeller. It should be understood that the terms attractor and repeller are employed for their convenience in describing a homeostatic situation relative to position on a control graph, and the tendencies of a system to change state, at various locations within the graph. It should also be understood that attractors and repellers can be defined with respect to a limited subset of the parameters influencing a parameter, for example, between two of three, four or more variables known to influence the parameter. Potentially, factors outside a particular attractor's definition appear as driving forces, serving to deflect a set point from its equilibrium position as defined for the subsystem. As defined for a space of larger dimensions, an attractor may be thought of as having a range of influence within which a set point orbits, according to the various driving forces acting on it. Even if the attractor fully defines the forces at work, the attractor's direction of pull is potentially different at different nearby points in the control space. This can lead to a form of a naturally “orbiting” attractor, for example, if a system's set point evolves as a function of its own recent history.

In some embodiments of the invention, a disease state comprises the appearance and/or strengthening of attractors and repellers which tend to move a system away from a healthy set point, toward a set point which is pathological. Additionally or alternatively, a repeller in particular can block the system from reaching a healthy set point, by acting as a barrier. In some cases, a system's normal attractors and/or repellers are weakened and/or relatively weakened according to changes in innervation, responsiveness, health, or another parameter. In some embodiments, vulnerability to a pathological attractor and/or repeller is limited to a particular range of circumstances, for example, during a particular part of a diurnal cycle, during a condition of stress, or another temporary condition. In the case of an “orbiting” set point, the orbit itself may define periods of particular vulnerability.

In another example, ANS control affects the maturation of some of the body's cell lines; in particular, immune cells in the spleen. Certain sympathetic and parasympathetic innervation conditions activate T cells, in some cases to become “killer” cells.

Some exemplary embodiments of the invention relate to identifying compromised innervation of the spleen. Potentially, compromised innervation induces

certain autoimmune disease states and/or cancer types. For example, a body's immune system and particularly the T cell population are involved in recognizing targets as host or an invader. T cell lines are among those under the control of the ANS.

ANS-induced T cell population lines are potentially induced according to
5 common function. In the case of a patient that has areas of the spleen that are denervated, a potential result is multiple T cell line functional groups induced, with loss of specificity being at least partially due to disruption in ANS stimulation in the innervated areas; for example, due to differential ANS stimulation in the denervated areas. The effect of such non-homogenous ANS innervation can potentially be large
10 dispersion of the range of T cell lines present at a given point in the patient body. Such disruption can in turn lead to the induction of autoimmune disease.

Another example relating to the immune system relates to patients with rheumatoid arthritis patients. Potentially, selective denervation (such as partial denervation) regresses the damaging immune response of rheumatoid arthritis patients.
15 Total splenic denervation, however, potentially accelerates the progression of generalized atherosclerosis. The knowledge of spatial distribution of innervation/denervation has potential importance for understanding ANS-related disease mechanism of rheumatoid arthritis, and is potentially useful in designing a treatment to combat disease. For example, where denervation is indicated, it is a potential advantage
20 to concentrate denervation where it will restore a particular pattern of innervation (for example, a more nearly normal pattern, a better balanced pattern, or another selected pattern), instead simply reducing innervation to the organ/system without selection as to the portion which is adjusted.

In some embodiments of the invention, ANS activity in a patient with severe
25 rheumatoid arthritis is imaged, for example according to a method mentioned and/or described herein. Optionally, a search for areas in the spleen that have "unbroken" ANS innervation are identified, allowing selective "breakage" of ANS innervation by targeting target fibers/ ganglia of the ANS that supply zones that are chosen for elimination from control. Potentially, the targeted selection allows avoiding side effects
30 of a general ablation, such as accelerated atherosclerosis.

In some embodiments of the invention, means to quantify and/or localize the non-homogenous ANS control of an organ/system are provided. Potentially, this lets the

operator assess the likelihood of a “broken” ANS as a cause for a disease state. Optionally, means to compare an observed pattern of ANS innervation to one or more normal and/or diseased state pattern templates are provided. In some embodiments, an operator is informed of and/or is provided with input tools to refine the result of an automatic assessment, which is linked to a previously determined association between a template pattern and a disease state that it potentially underlies. For example, if a template comprises assumptions about anatomy which do not match the particulars of an individual patient, the operator is provided with an opportunity to adjust the template to allow the automatic assessment to proceed. Optionally or alternatively, the template is provided with a description of potentially ambiguous situations, for which it alerts an operator that the automatically determined matching should be verified by a human operator.

In some embodiments of the invention, additional means are provided to allow and operator of a therapeutic system, such as a therapeutic system described hereinbelow, to plan and predict the effect of certain ANS / tissue interventions to counter the effect of the “broken” ANS state. Optionally, a therapeutic system is configured to administer therapy, for example by means of drug administration (for example, general or localized), stimulating signal delivery, an ablation technique, or another method of treating the observed ANS dysfunction.

An aspect of some embodiments of the present invention relates to means and/or methods for diagnosing and/or determining a treatment using a model of the nervous system, and or patterns derived from measurements of the nervous system. In some embodiments, the model or pattern is based on an activity map of the autonomic nervous system (ANSmap). In some embodiments, the ANSmap is determined according to a distribution pattern of radiolabeled marker, the distribution pattern being determined, at least in part, according to functional (for example, neurotransmission) activity in the ANS. Optionally, the determined treatment is suggested to an operator. Optionally, determination of a treatment comprises comparing the model of or pattern demonstrated by the nervous system of the patient to a normal model/pattern (such as a model/pattern corresponding to the system of a healthy person, optionally matched and/or controlled, for example, for age, size, sex, and/or another parameter). Optionally, determination comprises matching the results of the comparison to one or more

treatment options available to the system. Optionally, available treatment tools are taken into consideration when determining the treatment.

In some embodiments a “model” comprises a description having parts with assigned mappings to aspects of the system being modeled. Some models have a predictive aspect; for example, the model can be changed in order to make a prediction about the behavior of the system it models if subjected to a similar change. In some embodiments, a “pattern” is any set of observations or pseudo-observations that capture a state, with or without interpreted meaning attached. A typical feature of a pattern is that it can be compared to other patterns, and classified, categorized, or otherwise assigned an interpretation, whether or not relationships among its internal parts are themselves interpretable. A “model” can be considered a specialized form of pattern having interpretable relationships among its parts which correspond to the thing modeled. However, the line between model and pattern is not necessarily clear-cut, and it should be understood, herein, that where a model is described in an aspect which applies also to a pattern, a parallel and/or broader pattern description is also intended.

In some embodiments, the method comprises acquiring information relating to activity of the nervous system, acquiring information relating to the subject anatomy, co-registering the acquired information, and transmitting the hybrid information (for example, in the form of a guiding map) to guide a treatment agent for treating disease.

In some embodiments of the invention, information relating to nervous system activity is acquired in relationship to a particular physiological and/or signaling state. Optionally, the physiological or signaling state is a naturally occurring state, such as blood glucose level in relation to a meal, parasympathetic innervation in relation to arousal, or another state. Optionally, a signaling state is artificially induced, for example, by exogenously stimulating a nerve, GP, or portion thereof. In some embodiments, a finer mapping of connections between a nerve or GP and an innervation target is obtained by artificial stimulation. Optionally, this mapping is used in diagnosis, treatment planning and/or carrying out treatment. It should be noted that this potentially is carried out in some embodiments, as a form of “non-imaging” mapping (though the result itself may be an image), in that the connections which are determined link a stimulus delivery position to innervation target are not necessarily localized within an image; rather localization is with respect to a position from which stimulation occurs.

Diagnosis and/or treatment of disease by modeling of and/or pattern-recognition in the nervous system, in some embodiments of the invention, comprises a working assumption that the human body operates under a closed loop control system. Optionally, the controlled loop maintains homeostasis. In some cases, the control system
5 faces a dysfunction or other condition, such as a heart attack. In such a case, where the heart might be damaged, with potentially resulting reduction in the blood pumping capacity of the heart, the control system may try to correct the blood supply deficiency by “overstimulating” the viable part of the heart. In some cases, such a correction potentially creates non-reversible damage to the heart, which can be associated with
10 reduced, or even impaired, cardiac performance. In some embodiments, the method includes identifying the part of the autonomic nervous system (ANS) that is responsible for such corrective action.

In some embodiments, dysfunction comprises overactivity or underactivity of a single side of a closed loop control system. Potentially, balance in the system is restored
15 by adjusting either the abnormal side, or a side of a loop which responds to it.

In some embodiments, dysfunction in feedback control comprises the entry into, and/or vulnerability to entering a “runaway loop”. In one type of runaway loop, although one side of a feedback loop responds with modulation (for example, increase or decrease) of an output, another side fails to respond as usual to provide damping on
20 the modulation. Potentially, this leads to increasingly strong modulation, with undesired side effects. For example, increased insensitivity to a control signal potentially follows from its overamplification, as another part of the control system compensates for what may be (from another perspective) unnecessary overactivity. Additionally or alternatively, control disturbances potentially occur (for instance) with respect to
25 increased sensitivity, over-reduction, and/or undercompensation. This potentially leads to a system state where parts no longer operate together within an appropriate range of responses and sensitivities. Entry to such a condition is potentially chronic or acute. For example, insulin insensitivity potentially develops over years, while breakdown in feedback in the heart can potentially develop within seconds.

30 In some embodiments, treatments guided by ANS mapping are tailored to the particular timing requirements of control system dysfunction. Optionally, the symptoms of loss of feedback control are only problematic at particular times. Potentially, the

problem is elicited under circumstances which may be predictable and/or recurrent (for instance, urination), and/or due to less predictable particulars of a subject's condition and/or environment (for example, stimulation of fight-or-flight ANS activity). For example, a potential effect of prostate enlargement is increased difficulty with urination—when there is a need to do so. The effect in such a case is recurrent. Erectile dysfunction is potentially only a problem in the context of sexual activity. A mismatch of innervation which increases vulnerability to heart fibrillation, on the other hand, potentially is triggered by a particular stress in the environment at an unpredictable time—while it is also necessary for the heart to function well at all times.

In some embodiments, treatment guidance by an ANSmap comprises determining a dose and/or timing of a treatment, such as drug administration. In some embodiments, parameters of the operation of a stimulation device, for example, a trans- or percutaneous device configured to stimulate a part of the ANS, are determined based on ANS map data acquired under one or more selected conditions. Optionally, the conditions are chosen to relate to the particulars of a disease—for example, glucose level, cardiovascular stress, and/or stimuli relating to tumescence. Optionally, ANS mapping comprises determining a contrast in activity levels between or among a plurality of conditions.

In some embodiments, a disturbed control loop comprises control of a single organ or system component. Control disturbance optionally comprises control disturbance relating to a whole organ or system component, and/or to a portion thereof. In some embodiments, a disturbed control loop comprises control of two or more organs or system components. Control disturbance optionally comprises control disturbance relating to a plurality of organs or system components, a whole organ or system component, and/or one or more portions thereof.

A dysfunction, in some embodiments of the invention, may refer to a dysfunction associated with an organ/system, and/or to a dysfunction associated with the control system of the ANS, and/or any combination thereof, for example a dysfunction associated with the ANS which causes damage to an organ/system and/or to a functioning of the organ/system.

The following are examples of applications that may be used with an Autonomic Nervous System Map (ANSmap), for example as described in the application.

Optionally the ANSmap is a non-invasive ANSmap (niANSmap). In some embodiments of the invention, functional mapping comprises indexing responses (in particular, response intensity) measured by a radiation-sensitive probe (for example a CZT detector) to each of a plurality of positions at which the responses measured.

5 Acquiring an ANSmap, in some embodiments of the invention, comprises using one or more autonomic nervous system tracers and locating regions of their accumulation on an anatomical image. In some embodiments, local tracer accumulation increases with increasing nervous tissue activity. In some embodiments, use and/or creation of an ANSmap comprises masking, to segment and/or select one or more
10 regions of specific interest. In some embodiments, use/and creation of an ANSmap comprises normalization, for example relative to an expected value, another ANSmap, a measured clinical parameter, or other data. In some embodiments, a system for analyzing an ANSmap comprises a workstation; for example, a computerized system including processor, memory, and interface inputs and outputs. In some embodiments, a
15 tool for treatment, for example, ablation, anesthesia, and/or stimulation of a GP or a portion thereof is guided by reference to an ANSmap. In some embodiments, a treatment workstation comprises display (optionally also production) of an ANSmap for direct guidance of treatment, for example, guidance of the positioning of a treatment probe.

20 In some embodiments of the invention, a data storage medium is provided having an ANS model (or pattern such as a visualization) stored thereon. In some embodiments, the stored information is not or is not merely an image, and includes ganglion related data, such as size, position, and/or intensity of activity. In some exemplary embodiments of the invention, the stored information comprises a non-image
25 representation (such as text) of the model/pattern information, including ganglion related data, such as size, position and/or intensity of activity. In some embodiments, what is stored is a manipulatable data structure, such as a scalable map.

 In some exemplary embodiments of the invention, a map is provided with structure in addition or alternative to an image's pixel array. For instance, the structure
30 includes segmentation which identifies certain features (such as ganglia and/or axons). In some examples, the structure includes additional data associated with parts of the image and/or segments.

In some exemplary embodiments of the invention, the representation includes location indications, for example, an anatomical location, body coordinates and/or a functional location. Optionally or alternatively to static data, dynamic data per ganglion may be stored, for example, a time based activation profile, correlation with
5 organ/system data and/or other dynamic data, for example, as described herein. In some cases, dynamic data may be provided as a table or function or time linked data. In other cases, dynamic data may be provided as statistics. Optionally or alternatively to ganglion data, what is stored is links between ganglia, for example, anatomical links (e.g., relatedness to a same body structure), physical links (e.g., connecting axons)
10 and/or functional links (e.g., functional relationship between activation at one and activation at the other). Optionally, the medium may include indications of relevant input sources to the ganglion structure, for example, body function and blood hormone levels.

Optionally or alternatively, the medium stores data relating to ANS innervation
15 and/or activity in target organ/systems. In one example, such data is provided as location indications, size/shape indications and/or static and/or dynamic data regarding activity in such locations.

In some embodiments of the invention, ganglion existence, links and/or data and/or input sources are stored as parameters for an ANS model- and/or
20 pattern-template, with the actual template, for example, being stored separately.

Some embodiments associated with the ANSmap are configured for diagnostic and/or therapeutic applications. Diagnosis, made with reference to an ANSmap, is based, for example, on:

- comparison of activity relative to a normal range;
- 25 • comparison of activity relative to prior data from the same subject;
- activity differences among organs, organ parts, and/or system components;
- dynamic activity response to stimulation; and/or
- disease state, wherein the ANS is a causative agent, or is responding to a non-ANS primary pathology.

30 In some embodiments, diagnosis based on ANS mapping provides a deeper understanding of the role of various signaling subsystems in the production of symptoms for which the original pathology is well understood. For example, an

enlarged prostate is well understood to potentially block the flow of urine. But the resulting symptoms of storage and/or voiding, are potentially individualized, as a result of the particular interplay of signaling and control existing in a patient. ANS mapping provides a potential means to select the right specific treatment for a more general
5 condition, based on an understanding of the particular pathway of progressions which the disease is taking.

Therapy, in some embodiments, is directed to ANS neural pathways and/or ganglia with the use of an ANSmap, for affecting function of at least one organ, organ system (or other functional system), and/or organ part. For example:

- 10 • Therapy optionally treats ANS over-activity by: ablating overactive neural tissue, stimulating the neural tissue innervating a non-overstimulated organ/system part, modifying neural tissue to balance organ/system function, and/or administering temporary local anesthesia (for example, to ganglionic plexuses, and for example with monitoring of the response).
- 15 • Therapy optionally treats ANS under-activity by: ablating neural tissue innervating the non-depressed part of the organ/system, stimulating under-active neural tissue, and/or modifying neural tissue to balance organ/system function.
- Therapy optionally treats organ/system primary pathology by: ablating neural tissue innervating contralateral to a diseased region, stimulating neural tissue
20 innervating ipsilateral to a diseased region, and/or modifying neural tissue to balance the function of the organ/system.

In some embodiments, a link between a diagnosis and a therapy is made through the use of one or more disease-treatment templates, models, and/or patterns. In some embodiments, the disease-treatment models comprise one or more criteria for absolute
25 and/or relative activity levels of one or more portions of the ANS. In some embodiments, a criterion includes reference to other relevant data, such as test results of blood content, organ/system function, or any other test relevant to the disease. In some embodiments of the invention, available data are matched to a number of available disease-treatment models and/or patterns, to increase confidence that a finding is
30 unambiguous (or, if the finding is ambiguous, to alert medical professionals to this). In some embodiments, a model/pattern is developed in part based on individualized findings. For example, individual variations in ANS anatomy are potentially imaged,

and the variations themselves incorporated into the available disease-treatment models/patterns. This is a potential advantage, for example, when innervation for multiple organ/systems passes through a particular region, of which innervation of a particular organ/system needs to be selected for adequate treatment.

5 In some embodiments of the invention, application of therapy comprises a sacrifice of an aspect of available function or control in order to prevent the occurrence of further degradation and/or of a dangerous acute event. For example, it is potentially better to reduce the responsiveness of a system which is vulnerable to uncontrolled swings away from homeostasis, even if this results in a steady-state or other daily
10 condition which is in some respect worse than the system is currently able to maintain. Optionally or alternatively, an uncontrolled feedback loop can potentially lead to an ultimate condition (for example, disease progression) which is worse than the one which the feedback is attempting to correct. It is a potential advantage to adjust a modulation signal in such a case such that the conditions leading to progression are reduced, even at
15 the cost of losing some of the system's existing responsiveness.

 For purposes of better understanding of some embodiments of the present invention, as illustrated in *Figures 1-10* of the drawings, reference is first made to the anatomy and function of an autonomic nervous system (ANS) of a mammal (e.g., human) as illustrated in *Figure 11*. *Figure 11* shows the components of an ANS **1100**, in
20 schematic form. As can be seen, the ANS includes a network of ganglia, also termed ganglionic plexi (GP). Nerve fibers meet and synapse at the ganglia.

 The human body has several control systems, including the hormonal system, the central nervous system and the autonomic nervous system (ANS). As traditionally depicted, the autonomic nervous system is (mostly) not under conscious control and
25 serves to regulate various body functions, including life-sustaining functions. For example, basal heart rate, breathing and digestion are controlled by the autonomic nervous system. In some classifications, the portion of the autonomic nervous system which relates to digestion is termed the enteric nervous system (ENS).

 A spinal column **1102** provides both sympathetic and parasympathetic
30 innervation. As shown, parasympathetic innervation **1106** may proceed directly to organs **1114** and/or to secondary ganglia **1110**. Sympathetic innervation **1108** may be modulated by the spinal ganglia and then feed into secondary ganglia **1110** or organs

1114. In many cases, the sympathetic and parasympathetic innervations interact at the secondary ganglia **1110** (such as the ciliary, celiac, and other ganglia). Secondary ganglia **1110** may be connected directly to nerve endings **1112** at an organ **1114**. In some cases, an intermediary network or chain of ganglia exists as well (not shown).

5 The ANS is generally considered to include two main functional layers, the sympathetic nervous system (SNS), generally (but not exclusively) in charge of excitatory and increased responsiveness and control, and the parasympathetic nervous system (PNS), generally (but not exclusively) in charge of damping responsiveness and control. For example, heart rate is increased by increased activity of the SNS and
10 decreased by increased activity of the PNS. In some organs, such as the heart, the nerve fibers of the SNS and nerve fibers of the PNS meet at certain ganglia. Ganglia which include both SNS fibers and PNS fibers utilize a balance between the excitations of the SNS and PNS to determine their behavior.

 The ANS includes both afferent (leading towards the innervated tissue) and
15 efferent fibers (leading away from the innervated tissue).

 From a perspective of diagnosis, it is recognized that malactivity of the ANS may cause body dysfunction, for example, in atrial fibrillation. Furthermore, general ANS tone is considered to be related to some diseases such as high blood pressure. Damage to the ANS can sometimes occur, causing organ dysfunction, for example, in
20 transplanted organs.

 From a perspective of treatment, some examples of treating an undesired condition by ablating a part of the ANS have been suggested.

 An aspect of some embodiments of the present invention relates to the analysis of disease state by comparing measurements of ANS activity to one or more other
25 physiological state measurements, at different levels of activity and/or measurement.

 In some embodiments, the measurements are analyzed for classification as potentially reflecting a pattern associated with a pathology of control. In some embodiments, the measurements are analyzed for extraction of features of a control function (expressible, for example, as a graph or map) which describes the governing of
30 feedback and/or feed-forward relationships among ANS activity and the one or more physiological states measured. In some embodiments, the features extracted comprise divisions of a control map according to slope. For example, the divisions correspond to

regions of the control map having a monotonic slope. Optionally, the features extracted comprise “attractors” and/or “repellers”, which are expressed, for example, as zones of division between zones of monotonic slope. In some embodiments, the control function is expressed dynamically. For example, the function relating activity and a physiological parameter optionally evolves as a function of its own history.

In some embodiments of the invention, identified features of a control map correspond to a feature of an underlying pathology. For example, a homeostatic system that the control map describes can contain a preferred, normal and/or healthy zone having an attractor region representing a preferred state of the system, to which it returns after perturbations. In some embodiments, however, another region of the control map represents a deranged state comprising another attractor. If pushed into the vicinity controlled by this attractor state, the system can potentially remain there indefinitely, rather than returning to the preferred set point as should normally occur. A “repeller”, in this case, can potentially comprise a barrier to leaving the pathological attractor's zone of influence. It should be understood that other variations affecting the “landscape” of a control map can occur, for example, a raised minimum, and/or a lowered barrier allowing escape from the preferred system state, potentially to a region of increased pathology.

In some embodiments, identified features of a control map form a basis for further determinations. In particular, further determinations optionally comprise a diagnosis of the pathology. Optionally, the further determinations comprise suggestion and/or selection of one or more treatment options. Treatment options arise, for example, from (optionally machine-learned) experience that a particular pattern responds well to a particular treatment. Additionally or alternatively, a treatment option is determined by the application of reasoning to a control map. For example, a particular ganglion found to be especially associated with an inverting relationship to a physiological parameter can be targeted for activity suppression, based on its activity level in the control map region of a repeller and/or attractor.

In some embodiments, a diagnosis comprises an analysis of ANS activity which highlights particular ANS features (for example, ganglion, efferent, or afferent) and/or controlled tissue as being implicated in derangements occurring within the zone of a pathological attractor and/or repeller.

In some embodiments, a suggested treatment comprises a determination that actions to treat a particular ANS feature and/or controlled tissue are likely to restore a more nearly normal form to the control map, and/or remove regions of the control map of particular risk to the patient. In some embodiments, control is substantially impaired, in order to remove the possibility of a particularly harmful state of mal-control being entered. In some embodiments, the determination is based on a prior diagnosis determination based on features of the control map.

In some embodiments of the invention, there is provided an apparatus and/or method for determining a pattern of autonomic innervation activity associated with a medical condition; and guiding a therapeutic agent to adjust the determined pattern toward normal physiologic state and away from the diseased state.

In some embodiments, determination of the pattern comprises comparing autonomic neural activity relative to:

- an organ/system function;
- organ/system function over a range;
- organ/system function over a range and monitoring the change with the activity of the autonomic neural activity; and/or
- an organ/system function over a range to identify regions where a monotonic relationship between the autonomic neural activity and the organ/system function exists.

In some embodiments, determination of the pattern comprises identifying the organ/system function that is:

- associated with the lowest or the highest autonomic neural activity;
- associated with the minimal autonomic neural activity of different organs/systems; and/or
- associated with the minimal autonomic neural activity of different members of the autonomic nervous system.

In some embodiments, determination of the pattern comprises identifying the relationship between organ/system function and autonomic neural activity of different organs/systems.

In some embodiments, determination of the pattern comprises identifying attractor and repeller domains:

- of each of the members of the autonomic nervous system;
- of the members of the autonomic nervous system of the organ/system function;
- that are within pathological domains of the organ/system function; and/or
- that have minimal or maximal neural activity associated with pathological domains of the organ/system function.

In some embodiments, the apparatus is operable for or more of the following functions relating to a control map describing a control relationship between autonomic neural activity and organ and/or system function:

- to measure and derive the monotony of the relationship between autonomic neural activity and organ/system function;
- to measure and derive the peak and trough of the feedback control relationship between autonomic neural activity and the organ/system function;
- to identify attractor and repeller values of a member of the autonomic nervous system;
- to identify changes to make in attractor and repeller values such that the organ/system will retain function within the normal physiologic/healthy domain; and/or
- to identify modes of other members of the autonomic system that change attractor and repeller values such that the organ/system will retain function within the normal physiologic/healthy domain.

In some embodiments, the treatment apparatus and its method for use comprise one or more of the following:

- information generated in determining of a pattern or model;
- guidance, based on such information, of intervention toward organ/systems/members of the autonomic system for which affecting their function will drive an organ/system toward the normal/healthy domain, and/or toward an attractor within that domain.

A further example relating to the immune system relates to patients with cancer. It is known that certain lines of cancer cells (LINE YY, for example) release certain chemical substances that affect the autonomic nervous system either directly or indirectly by modulating the response of certain ganglia to inputs that cause increased sympathetic activity to activate a specific immune cell maturation. The more line YY

cells there are, the more the set point of the ganglia is changed, resulting in reduced sympathetic activation to address the increased inflammation being sensed by the afferent pathways to the ganglia. The inappropriately reduced sympathetic activity from the ganglia halts the maturation of certain killer T immune cells that would otherwise be produced to fight the YY cancer cells. Potentially, restoration of an appropriate balance of activity helps in the reduction of cancerous growth.

Another example relates to patients with minimal atrial fibrosis, where electrical conduction between cells is minimally impaired under normal operating conditions. Occasionally, people experience a premature atrial beat: this premature atrial beat usually is followed with a compensatory period that allows the atria to become over-extended. The stretch receptors within the wall of the atria provide afferent fibers input to certain ganglia adjacent to the atria. These epicardial ganglia, upon sensing increased stretch in the atria, respond by increasing sympathetic transmission and reducing parasympathetic tone to the atria. This increases the force of contraction of both the atria and the ventricle and reduces the stretch on the atria wall, tending to bring a healthy heart back into a proper operating range. However, the same mechanism in patients with fibrosis of the atria can bring about induction of atrial fibrillation. Increased sympathetic and decreased parasympathetic activity is associated with atrial fibrillation. Moreover—in the case of induction of atrial fibrillation—the stretch in the atria will paradoxically increase. Feedback leads to increasing the sympathetic tone still further. Once in this self-perpetuating state, spontaneous termination of the arrhythmia is difficult to achieve: the more arrhythmia, the more stretch is induced, and the more sympathetic stimulation is generated.

Such situations—where an interrupt delivered to the system drives it away from its current attractor (or set point) toward a pathologic attractor (or set point)—show how a vulnerability can be aggravated when a potentially brief excursion from a homeostasis moves the system over a “hump”, to a place from which the pathological attractor becomes stronger due to entry into a vicious cycle.

It is noted that throughout the application, the term GP, GPs, ganglion and/or ganglia may also refer to a synaptic center, to encompass regions other than ganglia (such as where a nerve meets an organ), as it may be difficult to differentiate between a ganglion and a GP. In some cases, the difference between an individual ganglion and a

synaptic center comprising a plurality of ganglia (e.g., a ganglionated plexus) is merely semantic (that is, wherein different people in the art use different terminology) and/or of no significant medical importance.

Before explaining at least one embodiment of the invention in detail, it is to be understood that the invention is not necessarily limited in its application to the details of construction and the arrangement of the components and/or methods set forth in the following description and/or illustrated in the drawings. The invention is capable of other embodiments or of being practiced or carried out in various ways.

Before explaining at least one embodiment of the invention in detail, it is to be understood that the invention is not necessarily limited in its application to the details set forth in the following description. The invention is capable of other embodiments or of being practiced or carried out in various ways.

Medical Condition Examples

Following are examples of medical conditions to which the invention, in some embodiments thereof, is applicable. Optionally, application uses an ANSmap in diagnosing a condition, guiding treatment, and/or evaluating response to treatment.

In some embodiments of the invention, and in several of the examples presented, an outline is followed, in which: an ANS map is generated according to conditions appropriate to a disease, the disease state is determined based upon processing of the ANS map, and an outcome is generated on that basis—for example, a diagnosis or a treatment plan.

Diabetes

Reference is now made to Figure 3, which schematically shows a method **300** of using a map of autonomic nervous system activity in the evaluation and/or therapeutic treatment of diabetes, according to some exemplary embodiments of the invention.

Diabetic disease and glucose control. Glucose, though an important energy source for metabolism (among other functions), is toxic if over-concentrated in the blood. Diabetes mellitus type **2** is a metabolic disorder wherein hyperglycemia occurs together with insulin resistance and/or insulin lack, producing potentially severe long- and short-term health effects. Among other organs involved in glucose regulation, the pancreas is normally a regulated producer of insulin. Glucose uptake and release are

regulated target functions adjusted by insulin, for example in liver and muscle. Liver glucose uptake is particularly important for regulation of blood glucose levels.

ANS involvement in glucose control. The ANS is involved in modulating insulin release (and also thus, or through another pathway, blood glucose) both up and down: 5 by direct innervation, and by blood-borne hormones. Although the detailed picture is nuanced, it is generally accepted that the sympathetic ANS stimulates glucose release, while the parasympathetic ANS stimulates glucose storage.

A normal pancreas is connected to the ANS via specific parts of the celiac ganglia (large sympathetic ganglia innervating the digestive tract), and the vagus nerve 10 (a major source of parasympathetic innervation of the internal organs). Signaling molecules associated with the parasympathetic ANS that stimulate insulin release include acetylcholine; sympathetic ANS-sourced or -stimulated inhibitors of insulin release include norepinephrine and epinephrine. Epinephrine is a blood borne hormone, released, for example, by the adrenal glands under sympathetic ANS stimulation. 15 Sympathetic ANS-sourced catecholamines are a mixed stimulating and inhibiting signal, depending on receptor type.

A normal liver is connected to the ANS via different parts of the celiac ganglia (sympathetic ANS), and of the vagus nerve (parasympathetic ANS). In particular, insulin signaling activates the hypothalamus of the brain, and through the vagus nerve, 20 leads to decreased glucose production by the liver through downregulation of gluconeogenic enzyme activity. Sympathetic activation increases glucose output.

Functional inhomogeneities and mismatches. A variety of situations potentially produce inhomogeneity and/or mismatch of function, arising, for example, from changes to the above sketch of signaling pathways involved in insulin release and/or 25 response.

Potentially, the controlled function of one or more organs or system components involved in a function (pancreas and liver, for instance) becomes deranged without appropriate compensation in one or more other organs, resulting in functional mismatch. Effects of such mismatch are described hereinbelow.

30 Potentially, control of a single organ or system component is not homogeneous, and/or becomes inhomogeneous over the course of a disease such as diabetes. It can be understood, for example, that wherever there is direct innervation which affects a

function distributed across a significant extent of an organ (as is the case for pancreatic insulin release, and/or liver glucose production) there is a potential for partial denervation or another derangement of innervation distribution that leaves organ/system parts under unequal control. Since sympathetic and parasympathetic control are exercised by different control subsystems, it is possible for one aspect of control to be damaged while the other is intact, or for both to be damaged in a different pattern of distribution. Even blood-borne control by hormones is potentially prone to develop spatial differentiation as result of developed concentration gradients and/or circulatory impairment.

Potentially, functional responsiveness to control of a single organ and/or system component is not homogeneous, and/or becomes inhomogeneous over the course of a disease such as diabetes. Reduction of functional responsiveness (considered, for example, as a reduction in function at some fixed control input level) can occur over all of an organ or system component, but potentially only in a part of it or differentially across the whole, depending on the cause of the reduction.

Actual function potentially becomes inhomogeneous, even when change itself is homogeneous. Interactions between signal level and functional sensitivity are potentially non-linear. For example, a region of pancreas potentially receives a “supramaximal” amount of innervating insulin control normally in one part, and only nominally effective insulin control in another; thus, an evenly distributed reduction in absolute organ and/or system component function could still result in a mismatch in response such that the “supramaximally” controlled region continues to produce insulin under full control, while the nominally controlled region begins to underperform.

Possible effects of inhomogeneities and mismatches. Where one or more whole organs of a plurality of different organs operating within a homeostatic system escapes control, or a part of control, for example, by one or more of the changes described above, it is possible that regulation of homeostasis will simply fail. However, there are many potential scenarios where a regulatory system continues to operate, though in a pathological, part-pathological, or vulnerable state. For example, if the liver loses insulin sensitivity, it potentially occurs that the pancreas increases insulin production. This could, for example, insufficiently affect the liver, leaving glucose regulation in an impaired state. Alternatively, the liver is sufficiently affected to maintain glucose

regulation, but the strain on one or more signaling mechanisms and/or functional outputs leaves the system vulnerable to a future insult. In another type of scenario (whether or not the liver is sufficiently affected), excess insulin potentially over-affects or otherwise disturbs one or more additional organs which are not otherwise impaired (such as the muscles, which also are under a level of insulin-mediated regulatory control). Thus, a control system's own efforts to correct one functional imbalance potentially create another functional imbalance.

Even with net preservation of at least an imperfect control, functional derangements/mismatches potentially produce a pattern of regulation which is significantly different from a better achievable arrangement, even considering the loss of inherent function. This is potentially due, for example, to inadequate adaptation or over-adaptation of the associated control machinery, and/or due to instabilities introduced. For example, a normal organ system potentially has different parts operating on different time scales, and/or with different sensitivities. Loss of a "fast reacting" component, for example, potentially leads to overreaction by a "slow acting" component.

Effects of functional and/or signaling inhomogeneity and/or imbalance potentially comprise increased difficulty in achieving homeostasis at all. For example, pancreatic control, and thus control of insulin release, potentially becomes divided in a disease condition across the pancreas (into two, for example, though the division may be into more parts, a continuous range, or another configuration). The result is potentially to produce different feedback loops, each with its own "set point" (target glucose concentration) and/or rates of control (a different balance of fast innervation and slow hormonal response, for example). The interaction of such loops has the potential to become unpredictable, and possibly chaotic. Potentially, the extremes of occasional chaotic regulation (for example, producing a sharp, wide swing in blood glucose level) are more dangerous to health than a condition of normal homeostasis which is less than the best achievable (for example, slower-reacting to glucose entering the bloodstream from a meal). In some embodiments, a treatment is aimed at adjusting a control system to prevent extreme swings, potentially at the expense of sacrificing optimal baseline control.

In another example of an ANS derangement, ANS control over an organ/system function is brought about by interactions between a local control loop and one or more non-local control loops. The control components of the system regulating blood sugar, for example, comprise one or more of each of the following:

- 5 • *sensing member*, measuring the level or activity or a physical property or other inputs;
- *processor member*, integrating the sensed activity information and comparing it to a reference state; and
- 10 • *effector member*, which affects the controlled organ and/or system component to alter, for example, a certain rate of activities within the controlled organ and/or system component.

Each of these members has a potentially non-linear relationship between its input and its output. This is a typical “unit” arrangement of homeostatic control for many organs/systems, but it should be understood that these units are often deeply interconnected. The sensing, processing and effector members are potentially connected one to the other and/or to other sensing, processing and effector systems.

A pathology in the control system controller can come about by affecting one or more of the relationships between input and output of any of the members. Some members have additional connections to a higher level of control. For example, a processing member is potentially a controlled organ for a higher level control loop. Additionally or alternatively, a processing member output affects the domain of an adjacent or remote processing member (for example, controlling a different organ).

Connectivity between different control loops is potentially at any or all levels of each loop member. Potentially, this results in a subsystem being locked into an externally driven state that is outside the healthy range.

For example, a patient with early stage diabetes is presented with hypoglycemia following meals. This potentially manifests, for example a lowered sensitivity of a sensing member in the gastrointestinal tract that relates sugar ingestion to rising incretin hormones. In more advanced early cases of diabetes the lower slope is potentially so low such that it appears as a delay in the response of incretins to ingested sugar.

The delay in the response to ingested sugar potentially allows more ingested sugar to enter the blood, driving blood sugar level higher. Liver gluconeogenesis has not

yet been shut down, so this also drives blood sugar higher. The sugar levels, accordingly, are elevated compared to a healthy person. When ingestion stops sugar level begins decreasing. Then, however, the delayed incretin rise will finally have its effect. Insulin level rises, shutting down liver gluconeogenesis and initiating liver glycogenesis (building of liver glycogen storage). Blood sugar thus decreases—
5 potentially to a hypoglycemic level.

Thus, delay in input signal potentially drives a control system of blood sugar to induce post-prandial hyperglycemia followed by post-prandial hypoglycemia. In some embodiments of the invention, an ANSmap shows the activation of a sensing member,
10 potentially including its strength, and/or its activation slope (increasing level of response over time). The ANSmap may comprise information taken from a plurality of periods before, during, and/or after a meal, for example, to allow measurement of activation slope according to changes among the information.

Optionally, this allows the treating physician to localize of the pathology within
15 the control system that is causing the disturbance in blood sugar levels. Optionally, treatment is by altering the slope of the response of incretins to ingested sugar. Optionally, the slope is maintained, but activation is begun earlier than the start of the actual meal. Adjustment and/or early activation is achieved, for example, by a pharmacologic administration, and/or by direct (for example, electrical or
20 electromagnetic) stimulation of the ganglia connected to the sensing member.

The large number of possible disease scenarios which the foregoing mechanisms indicate—different in detail, though still forms of diabetes—serves as an illustration of the potential value in obtaining data which characterizes ANS function in a disease state (provides a characterizing description of ANS function and/or its effects), and using it
25 for disease analysis, tailored treatment, and/or verification of results.

In some embodiments, the following method, including one or more of the blocks in the shown order or in a different order, is suggested. The flowchart of *Figure 3* begins, and, in some embodiments, a SPECT (single photon emission computed tomography) or other ANS activity image and/or other data structure mapping the
30 abdomen is obtained at block **310**, an anatomical imaging of the abdomen is acquired at block **312**, and the functional and anatomical data are co-registered at block **314**, for example as described in relation to *Figure 8*, hereinbelow. It should be understood that

combinations of blocks **310**, **312**, and/or **314** comprise one or more means—exemplary and non-limiting—by which sufficient data are gathered, in some embodiments, in order to enable the performance of operations described in relation to other blocks of the flowchart.

5 In some embodiments of the invention, the images described as being of the abdomen are limited to one or more organs or organ regions of particular relevance. This should also be understood with respect to other descriptions of imaging regions hereinbelow, changed as necessary. For example, images of the pelvis and/or lower abdomen are potentially restricted to a particular organ or organ of interest such as the
10 prostate, bladder, corpora cavernosa, or another organ of interest.

 In another example: in some cases, a specific organ contains the sensory apparatus which reports a parameter via the ANS. For instance, the lipid content of a meal is sensed by certain receptors located in the duodenum, which modulates in turn the pathways connecting these sensors to the ANS system, which can in turn affect
15 hepatic fat metabolism. In some embodiments, this is a locus of control to which a diabetes treatment is directed in some patients. In some embodiments, the region of interest will be ganglia transmitting the afferent signal of these fat duodenal receptors.

 In the case of diabetes, for example, information is collected, in some embodiments, from pancreas, liver, stomach and/or the celiac plexus. Diabetes is
20 potentially affected by multiple nodes of the ANS in multiple organs, although exemplary embodiments described hereinbelow focus on, the pancreas and liver in particular. Functions which related to the diabetes disease process potentially include, for example, food ingestion, absorption, gastric hormone secretion, small intestine hormone secretion, pancreatic hormone secretion, and/or liver metabolism.

25 In some embodiments, information is collected from beyond the abdomen. For example, there is some central nervous system (CNS) involvement glucose level and liver metabolism control. Potentially, an image includes a structure such as the hypothalamus.

 In other diseases as well, some embodiments comprise ANS mapping of up to
30 the entire body, although embodiments are discussed in terms of particular body regions for the sake of clarity of exposition. Potentially, this allows viewing measuring and

deducing from more complete information about the disease process, and concomitantly more exact planning of a subsequent intervention.

In general, it should be understood that there is a tradeoff made between obtaining maximal image information relevant to planning an optimal treatment from those available, and focusing selectively just on those targets most likely to be relevant to the particular disease state.

In some embodiments of the invention, activity imaging of block **310** is synchronized with respect to functional and/or control loads on a homeostatic organ system. For example, imaging is after a predefined period of fasting, and/or within one or more predetermined periods after eating. Optionally, images are taken during a period sufficiently removed from the last meal (and/or a need for another one) that the digestive system's ANS is potentially in a relatively quiescent state. Alternatively, the subject has fasted to the point that activation of glucose release is required. Optionally or alternatively, images are taken while the digestive system is managing an incoming glucose load which requires a significant increase in glucose uptake activity. Optionally or alternatively, images are taken while the digestive system is in an undershoot mode, where blood sugar is low. Optionally, imaging is of the ANS effects of administered insulin, epinephrine, or another hormone related to blood glucose regulation.

At block **316**, in some embodiments, ANS activity data is evaluated for parameters including, for example, location (for example, absolute and/or relative to one or more other organs), size (for example, absolute, and/or relative to the size of one or more anatomical structures of the body), intensity (for example, absolute, relative to a standard, relative to one or more other locations), type (for example, sympathetic or parasympathetic), likely effect on an innervated organ and/or system component, and/or another parameter of activity, for example as described hereinbelow. Optionally, one or more masks are applied, appropriate to the condition being evaluated. In some embodiments of the invention, one or more masks are determined based on conditions such as those described in relation to **310**, above. For example, one or more patient-specific masks of glucose-regulatory ANS activity are generated based on imaging under different activating conditions. Optionally, the conditions chosen for mask generation are relatively extreme, to acquire good differentiation of masking. Optionally, treatment is evaluated based on an ANS map of another state, wherein it is

potentially harder to distinguish which part of the ANS is selectively responsible for a specific innervation, except in view of the previously acquired mask. It is a potential advantage of such embodiments to overcome variability in anatomy, by activating a subject's own anatomy to achieve a clear, stereotyped pattern which guides (in the form of a mask, for example) the understanding of another, less clearly stereotyped pattern—
5 wherein potentially lie clues to the individual's disease state.

Optionally, any of the parameters is normalized. In some embodiments, normalization is performed among images taken at different regulatory states, for example, as described in relation to block **310**, hereinabove. For example, pre-meal and
10 post-meal ANS activity states are compared to reveal differential activation as a result of blood glucose and/or glucose availability changes. In some embodiments, compared images are among visits separated by days, months, or years. Potentially, such longitudinal comparisons increase the sensitivity with which physiological changes can be assigned to specific neural components. Other examples of normalization include, for
15 example, intensity of ANS activity being normalized to the size, viability, secretion output, movement, and/or another non-ANS output or aspect of an innervated organ, organ part, and/or system component. Optionally, normalization is with respect to a change in a non-ANS output or aspect. It is a potential advantage to normalize data, for
20 example, in order to form a more reliable impression of whether innervation and function are in balance, and/or to detect changes and/or differences. In some embodiments, one or more activity parameters comprises anatomical and/or other data, for example as part of normalization.

At block **318**, in some embodiments, a plan for treatment is formulated, for example in light of the mapped ANS activity evaluated at block **316**. Optionally, further
25 information is used in formulating a treatment plan, for example, results of other evaluations including clinical history, clinical tests, genetic disease markers, and/or other imaging results. In some embodiments, the plan is formulated according to matching of one or more disease-treatment templates, for example as described hereinbelow.

30 A plan for treatment of diabetes, and/or a pre-diabetic condition, is optionally developed based upon specific findings from the ANS imaging. In some embodiments, one or more criteria are set as a model or pattern, to which available data are compared.

Matching of the model/pattern criteria to available data comprises a determination that a particular condition, related to a particular treatment option, has been isolated. Illustrative examples include the following:

5 In some embodiments of the invention, a finding of over-activity in the portion of the celiac ganglia involved in innervating the liver is made for some phase of digestion. For example, a model/pattern criterion is satisfied in which a high level of glucose is found in the blood, relative to what should be expected for a mapped level of activity related to this portion of the celiac ganglia. In some embodiments, one or more additional criteria are matched in order to confirm the finding of over-activity. 10 Optionally or alternatively, the finding of over-activity is in another sympathetic pathway involved in the ANS innervation of the liver. Sympathetic activation of the liver, associated with glucose production, potentially aggravates a condition of high blood glucose. Optionally, criteria of other models/patterns are examined to rule out alternative explanations of a particular ANSmap finding.

15 In some embodiments of the invention, a plan is made to at least partially ablate the over-active sympathetic innervation of the liver, with the goal of reducing glucose release. Optionally, where ambiguity remains with respect to other models/patterns which have not been ruled out, further tests are performed, and/or due caution is maintained in the planning of the ablation. Ablation comprises, for example, whole or 20 partial thermoablation, cryoablation, drug injection, anesthesia, or another intervention which reduces ANS activity.

In some embodiments of the invention, a finding of over-activity in the portion of the celiac ganglia involved in innervating the pancreas is made for some phase of digestion. For example, a disease-treatment model criterion is satisfied in which a high 25 level of glucose is found in the blood, relative to what should be expected for a mapped level of activity related to this portion of the celiac ganglia. In some embodiments, one or more additional criteria are matched in order to confirm the finding of over-activity. Optionally, the finding of over-activity is in another sympathetic pathway involved in the ANS innervation of the pancreas. Sympathetic activation of the pancreas, associated 30 with the inhibition of insulin production, potentially aggravates a condition of high blood glucose. Optionally, criteria of other models/patterns are examined to rule out alternative explanations of a particular ANSmap finding. In some embodiments of the

invention, a plan is made to at least partially ablate the over-active sympathetic innervation of the pancreas, with the goal of increasing insulin production. Optionally, where ambiguity remains with respect to other models/patterns which have not been ruled out, further tests are performed, and/or due caution is maintained in the planning
5 of the ablation. Ablation comprises, for example, whole or partial thermoablation, cryoablation, drug injection, anesthesia, or another intervention which reduces ANS activity.

It should be noted that both of the above scenarios relate to over-active innervation from a portion of the celiac ganglia. In some embodiments, a selection of
10 preferred treatment course from among these two options comprises observing that innervation activity specifically to the liver vs. the pancreas (or vice versa) is elevated. In some embodiments, a finding is that both types of innervation activity are elevated relative what is expected. Optionally, both treatment options are performed. Alternatively, only one is. Alternatively, neither is performed. In some embodiments,
15 additional criteria which are met to fit a disease-treatment model include criteria relating activity levels to levels of insulin, relating activity levels to maximum or minimum levels of observed activity (in different conditions), or one or more other criteria.

In some embodiments, another target for ablation is decided upon. For example, excessive production of adrenaline is potentially indicated by over-activity in the
20 innervation of the adrenal glands, and/or of the glands themselves. Optionally, the production of adrenaline is itself “normal”, but because it affects an impaired glucose regulation system, it is determined to reduce the capacity to produce epinephrine, to reduce stress on the damaged control system.

In some embodiments of the invention, a finding of over-activity in a portion of
25 the vagus nerve involved in innervating the liver or pancreas is made for some phase of digestion. For example, a disease-treatment model criterion is satisfied in which a blood glucose level remains high while vagus nerve activation is at a high level (for example, according to one or more chosen normalization schemes). In some embodiments, one or more additional criteria are matched in order to confirm the finding of over-activity.
30 Optionally, the finding of over-activity is in another parasympathetic pathway involved in the ANS innervation of the liver or pancreas.

High parasympathetic activation of the liver, associated with glucose uptake, potentially indicates a liver which has developed a level of insulin insensitivity (which overstimulation in turn potentially is partial compensation for). Additionally or alternatively, there is potentially insufficient insulin production available for uptake.

5 Optionally, a determination of the meaning of a particular level of activity is referenced to a measured level of blood insulin concentration.

High parasympathetic activation of the pancreas, associated with insulin production, potentially indicates a pancreas which is stimulated to over-produce insulin. Alternatively, the pancreas potentially is unable to produce sufficient insulin, resulting
10 in overstimulation to compensate. Optionally, a determination of the meaning of a particular level of activity is referenced to a measured level of blood insulin concentration.

A possible secondary effect of insulin resistance is hyperinsulinemia, which is separately detectable (for example, by assaying to check for high blood insulin levels),
15 and tends occur in early stages of type 2 diabetes. It is also associated with other diseases such as hypertension, obesity, dyslipidemia, and glucose intolerance. Potentially, hyperinsulinemia itself leads to further increases in insulin resistance, and disease progression as a result.

In some embodiments of the invention (where hyperinsulinemia is found, for
20 example, either through ANS activity imaging, or by another method), a plan is made to attempt to reduce long-term effects of hyperinsulinemia by reducing insulin production. This is an instance of sacrificing a level of available function in order to potentially preserve future function. In some embodiments, insulin production is reduced by ablating a part of the parasympathetic innervation of the pancreas. Optionally, where
25 ambiguity remains with respect to other models/patterns which have not been ruled out, further tests are performed, and/or due caution is maintained in the planning of the ablation. For example, the decision to ablate parasympathetic innervation of the pancreas is optionally contingent on a finding that parasympathetic innervation is notably overactive, and/or on a finding that parasympathetic pancreas innervation is
30 well-correlated with insulin level (for example, by imaging under different conditions of blood insulin levels). Otherwise, the risk that the ablation will be ineffective is potentially raised.

In some embodiments of the invention, the ANSmap is used to diagnose and/or verify the temporal, spatial, input adjusting, balancing, and/or outcome adjusting responses of an ANS subsystem. In more detail, these functional aspects comprise the following characteristics:

- 5 • *Temporal*: the change in function of members of the ANS control system in time with stimulation during a specific pattern of response to a state.
- *Spatial*: activation and deactivation of effector members, sensing members and/or processing members of the control system within and/or between organs and/or system components.
- 10 • *Input adjusting*: the slope connecting input and output levels of each of the members. Different input/output relationships can be normal in the context of a system. For example, a certain relationship between input and output of the sensing member can be abnormal, but the overall control of the organ/system still be normal if, for example, processor and/or effector function is changed to
- 15 compensate.
- *Balancing*: the use of balanced activation / inhibition and/or opposing or complimentary effects of the control system.
- *Outcome adjusting*: activity of the ANS control is judged by the end result of the controlled function of the controlled organ/system.

20 At block **320**, in some embodiments, a planned therapy is delivered. The therapy is, for example, an ablation, or another activity-affecting therapy such as delivery of a drug or other bioactive material, implantation of an inhibiting or stimulating bioactive material eluting device, implantation of a percutaneous electrical or magnetic field stimulating device, use of a transcutaneous electrical or magnetic field stimulating

25 device, or another therapeutic intervention. In some embodiments, the administration of therapy is under the guidance of an ANSmap. For example, a specific region of a GP showing elevated activity in an ANSmap is targeted, and a treatment probe guided to this region with specific (optionally, automated) reference to the targeted region.

30 At block **321**, in some embodiments, therapy results are monitored. In some embodiments, monitoring comprises re-imaging to verify that an intended effect of therapy on ANS activity actually occurred, and/or that no unintended effect occurred or is developing. In some embodiments, therapy is planned to be delivered in two or more

stages, with monitoring at each stage to verify that intended effects are occurring, have reached a desired level, and/or that potential side-effects are tolerable.

At block **322**, in some embodiments, a decision is made as to whether or not a treatment intervention has reached a sufficient level of success to terminate therapy. Additionally or alternatively, the determination relates to whether or not additional intervention is unlikely to improve an outcome. If yes, the flowchart ends. Otherwise, in some embodiments, flow returns to an earlier operation, for example, block **310**.

Benign prostatic hyperplasia (BPH)

Reference is now made to *Figure 1*, which schematically shows a method of using a map of autonomic nervous system activity in the evaluation and/or therapeutic treatment of benign prostatic hyperplasia (BPH), according to some exemplary embodiments of the invention.

BPH and lower urinary tract symptoms. In BPH—typically a progressive disease, and prevalent in older men—prostate stromal and epithelial cell numbers increase, sometimes to form nodules. Androgens such as testosterone, its metabolites, and related hormones, appear to have a role in promoting prostate cell proliferation. In some cases of traditional diagnosis, lower urinary tract symptoms (LUTS) suggestive of BPH are detected. Some cases involve urodynamic estimations, for example of urinary flow rate. In some cases, urethroscopy investigation is applied. In some cases, transrectal ultrasound scanning is applied.

Though benign, nodules or other growth can physically obstruct urine flow, for example by impinging on the urethra. Complications can include urine storage and/or voiding symptoms, progressing to changes in the bladder (detrusor) muscle and/or its control, urinary tract infection, bladder stones, and/or renal failure.

The relationship between observed signs of prostate growth and resulting lower urinary tract symptoms (LUTS) is potentially complicated by other states of associated organs, tissues, and/or system components. Possible complicating state factors include stimulation state of prostatic smooth muscle, variable details of prostate anatomy, and/or the changing state of the bladder, for example due to aging or obstruction.

Urinary storage and/or voiding symptoms resulting from BPH are, in some cases, linked to destabilization of bladder function, which is itself under significant ANS control. Bladder function can be damaged or disturbed, for example, by ischemia or

hypertrophy, which can potentially affect one or both of innervation or innate muscle function.

Treatment methods for BPH include phytotherapy, pharmacotherapy, surgical treatment, or other methods or combinations thereof. Related to its progressive (and
5 initially non-life threatening) nature, a goal of BPH disease management is optionally to balance quality of life issues against the risks and side-effects of treatment interventions such as surgery.

ANS involvement in the prostate and bladder, related to symptoms of BPH. The normal prostate gland is connected to both the sympathetic and parasympathetic ANS
10 through the prostatic nerve plexus. Innervation is both cholinergic (parasympathetic) and noradrenergic (sympathetic).

One role of sympathetic innervation is control of prostatic musculature (for example, via α_1 adrenoceptor activation). When acting in this role, innervation constricts the bladder neck and/or other smooth muscle of the prostate and urethra when
15 activated. Activation occurs normally, for example, during ejaculation of seminal fluid into the urethra. Several drugs which block α_1 receptors are used effectively to improve urine flow in patients with BPH. Such drugs include terazosin, doxazosin, alfuzosin, tamsulosin, and/or prazosin.

Effects on the prostate which have been suggested for noradrenaline (which
20 parasympathetic innervation of the prostate provides) include stimulation of stromal cell division. Both sympathetic and parasympathetic innervation have been suggested to have roles in the maintenance or growth of the prostate and prostate cell number.

Sympathetic innervation of the bladder normally includes fibers from the hypogastric plexuses and nerves. Parasympathetic innervation is from pelvic splanchnic
25 nerves and the inferior hypogastric plexus. At least some sympathetic (adrenergic fiber) innervation normally arises from local ganglia subject to hypogastric innervation.

In the bladder, sympathetic (adrenergic) activity tends to interfere with detrusor activation (bladder constriction) and the sphincter opening needed to expel urine; it acts in opposition to parasympathetic (cholinergic) activity, which normally occurs, for
30 example, in response to signaling from bladder stretch receptors. Thus, ANS activity in the bladder relates to some of the key symptoms affecting quality of life as a result of BPH.

In some embodiments, the following method, including one or more of the blocks in the shown order or in a different order, is suggested. The flowchart of *Figure 1* begins, and, in some embodiments, a SPECT (single photon emission computed tomography) or other ANS activity image of the pelvis and/or lower abdomen is
5 obtained at block **110**, an anatomical imaging of the pelvis and/or lower abdomen is acquired at block **112**, and the images are co-registered at block **114**, for example as described in relation to *Figure 8*, hereinbelow. It should be understood that combinations of blocks **110**, **112**, and/or **114** comprise one or more means—exemplary and non-limiting—by which sufficient data are gathered, in some embodiments, in order
10 to enable the performance of operations described in relation to other blocks of the flowchart.

In some embodiments of the invention, activity imaging **110** is synchronized with respect to functional loads on a homeostatic organ system related to prostate function and/or micturition. With respect to the bladder, for example, imaging
15 optionally occurs within a period of a predefined bladder state (such as filling, filled, or recently empty), within a period of predefined bladder sensing (such as a need to void), and/or within a period where a particular symptom is occurring (such as a symptom of a urine storage and/or voiding problem). With respect to the prostate, imaging optionally occurs within a period of sympathetic activation of the prostate (for example, during
20 erection). Optionally, imaging is of the ANS effects of administered testosterone, dihydrotestosterone (DHT), or another hormone related to prostate function.

In some embodiments of the invention, ANS stimulation by a selectively placed electrode (or other stimulus means) is performed in concert with ANS activity imaging, for example, to allow more detailed mapping of innervation targets within the fine
25 structure of a GP or nerve. Potentially, a GP or nerve contains a partial somatotopic map its innervation target. Optionally, denervation of a particular region of an organ can be targeted (for example, distributed evenly, and/or focused on a problematic region), based on activity observed in response to selective stimulation.

At block **116**, in some embodiments, ANS activity data is evaluated for
30 parameters including, for example, a parameter of one of the classes described in relation to block **316** of *Figure 3* hereinabove, changed as necessary to suit the anatomic and functional specifics of the prostate and/or lower urinary tract, for example as

described hereinabove. Normalization, in some embodiments, is performed, for example, according to one of the types of normalization described in relation to block **316**, or another normalization is performed. In some embodiments, a parameter is generated by comparison of activity images among ANS activation states, for example, among activation states described in relation to block **110**, hereinabove.

At block **118**, in some embodiments, a plan for treatment is formulated, for example in light of the ANS activity parameters evaluated at block **116**. Optionally, further information is used in formulating a treatment plan, for example, results of other evaluations including clinical history, clinical tests, genetic disease markers, and/or other imaging results. In some embodiments, the plan is formulated according to matching of one or more disease-treatment templates, for example as described hereinbelow.

A plan for treatment of BPH, and/or one or more symptoms relating to BPH, such as a micturition symptom, is optionally developed based upon specific findings from the ANS imaging. Illustrative examples include the following:

In some embodiments, by mapping neural activity associated with the prostate gland, severity of hyperplasia is estimated. For example, an extent and/or intensity of activity is measured in an ANS activity image.

In some embodiments of the invention, a treatment option is tailored based on ANS activity images. Several drug treatments related to BPH and/or its symptoms are known. For blockage of sympathetic innervation of the prostate, for example, the drugs terazosin, doxazosin, alfuzosin, tamsulosin, and/or prazosin are among those available. Reported side-effects for these drugs vary according to patient, drug, and/or dosage, and potentially include, for example, dizziness, headache, syncope (fainting), asthenia, postural hypotension, and/or retrograde ejaculation. Dosage required for optimal treatment is also potentially patient dependent. Other drugs target different mechanisms of BPH disease and/or its symptoms. For example, 5 alpha reductase inhibitors are aimed at reducing cellular division stimulated by androgens. In particular, they decrease DHT concentrations (DHT is a testosterone breakdown product). Known inhibitors of this class include finasteride and dutasteride. In another example, anticholinergic medications potentially help reduce symptoms of an overactive bladder, for example by reducing the effects of parasympathetic activation on the bladder. Combinations of

drugs acting on different mechanisms have been found to be effective in further reducing symptoms.

A potential use of ANS activity imaging as a basis for planning a drug treatment regime is to allow a more direct understanding of the underlying ANS picture which a drug is expected to affect. In some embodiments, overactive cholinergic innervation of the bladder provides a suggestion that anticholinergic medication is indicated. Optionally, a dosage is determined based on the degree of over-activity which is imaged.

In some embodiments, effects of drug treatment, for example, an α_1 blocker, are imaged with respect to dosage and/or time course after administration. A feature of some cases of PBH is that symptoms most interfere with quality of life only periodically through the day (for example, when the bladder becomes full, but urination remains difficult). Optionally, imaging results are used to determine a dosage, frequency, and/or timing of dosage, such that a desired level of drug treatment effect occurs at predictable times, while, during intervening periods, potential side-effects are lowered. In some embodiments, a dosage administered is determined based on imaged response to one or more test administrations of a drug. Potentially, this is an advantage for tailoring a treatment regime to the particular physiology of a patient, for example, by reducing a need for trial-and-error dosage determination.

In some embodiments of the invention, stimulation of sympathetic and/or parasympathetic innervation to the body of the prostate is carried out during ANS activity imaging, in order to correlate specific regions of imaged anatomy with one or more corresponding sources of innervation. In some embodiments, innervation which is specific to a nodule or other bulk in the occluding region of the prostate is noted. Optionally, innervation specific to the occluding region is ablated as it is found. Optionally, innervation is ablated after mapping, according to a subsequently planned procedure. A potential advantage of such selective ablation is to reduce innervation which possible contributes to maintaining or increasing prostate bulk in the region of greatest concern for current or future interference with urinary flow. Another potential advantage is to avoid the potential complications of direct surgical excision of prostate bulk, by instead treating neural tissue remote to the prostate.

In some embodiments of the invention, sympathetic and/or parasympathetic innervation of the bladder (and/or of somatic innervation which ANS innervation synapses with) is at least partially ablated or blocked, according to urinary storage or voiding symptoms of a patient. Potentially, this reduces bladder symptoms which trace to a sensing issue, by rebalancing the response of the ANS to stretch receptors in the bladder. In some embodiments, ablation or blockage is performed to achieve a temporary reduction of symptoms. Optionally, ablation is partial, leaving sufficient pathways for axonal regrowth that regeneration of the system occurs over a period of time (months) following treatment. Optionally, fibers which are ablated are, for example, sympathetic fibers showing particularly strong activation (tending to prevent detrusor activation), and/or parasympathetic fibers showing particularly strong activation (tending to induce micturition).

In some embodiments of the invention, a bladder innervation template is created, based, for example, on activity which is seen to arise in correlation with stimulation of various regions of the ANS bladder innervation. In some embodiments of the invention, ablation is performed under the guidance of an ANSmap to maintain relatively evenly distributed innervation of the bladder, for example, by ablating equally innervation reaching each of two or more subdivisions of the bladder wall. Optionally, ablation is during imaging which creates the map. Optionally or alternatively, ablation is during a second procedure, based on the ANSmap innervation template, and/or on additional findings, such as which regions of ANS activity are most closely associated with observed symptoms.

At block **120**, in some embodiments, a planned therapy is delivered to a nervous system structure related to the prostate or bladder. The therapy is, for example, an ablation, or another activity-affecting therapy such as delivery of a drug or other bioactive material, implantation of an inhibiting or stimulating bioactive material eluting device, implantation of a percutaneous electrical or magnetic field stimulating device, use of a transcutaneous electrical or magnetic field stimulating device, or another therapeutic intervention. In some embodiments, the administration of therapy is under the guidance of an ANSmap. For example, a specific region of a GP showing elevated activity in an ANSmap is targeted, and a treatment probe guided to this region with specific (optionally, automated) reference to the targeted region.

In some embodiments, a therapy is delivered for the sake of achieving an effect within the clinical setting, for the sake of determining its effect by means of one or more additional ANS activity imaging sessions. For example, an α_1 blocker is administered, and a time course and/or strength of response is noted in one or more additional ANS activity imaging sessions.

At block **121**, in some embodiments, therapy results are monitored. In some embodiments, monitoring comprises re-imaging to verify that an intended effect of therapy on ANS activity actually occurred, and/or that no unintended effect occurred or is developing. In some embodiments, therapy is planned to be delivered in two or more stages, with monitoring at each stage to verify that intended effects are occurring, have reached a desired level, and/or that potential side-effects are tolerable.

At block **122**, in some embodiments, a decision is made as to whether or not a treatment intervention has reached a sufficient level of success to terminate therapy. Additionally or alternatively, the determination relates to whether or not additional intervention is unlikely to improve an outcome. If yes, the flowchart ends. Otherwise, in some embodiments, flow returns to an earlier operation, for example, block **110**.

Erectile dysfunction

Reference is now made to *Figure 2*, which schematically shows a method of using a map of autonomic nervous system activity in the evaluation and/or therapeutic treatment of an erectile function disorder, according to some exemplary embodiments of the invention.

Erectile dysfunction. Erectile dysfunction (ED) is characterized by the inability to develop or maintain an erection during sexual activity. Normally functioning erectile tissue expands when the relaxation of smooth muscles of (particularly arteries within) the corpora cavernosa allows increased blood filling. Other musculature is activated to compress the veins by which the blood leaves these arteries. Among many other interacting mechanisms with a role in tumescence, several neural signaling and control pathways are involved in normal erectile function; damage or insult affecting any of these potentially manifests as ED.

ANS involvement in erectile dysfunction. In normal tumescence, parasympathetic ANS innervation triggers smooth muscle relaxation, for example, by causing cholinergic-triggered (more particularly, muscarinic M_3 -triggered) elevation of the

concentration of nitric oxide, a vasodilator. Parasympathetic innervation arises, for example, from the sacral plexus, and more particularly, from the pudendal plexus. These parasympathetic fibers run, for example, in the sacral nerves, including the perineal nerve branch leading to the dorsal penis nerve.

5 Activity from sympathetic innervation of the penis tends to cause arterial smooth muscle to constrict, reducing the volume of erectile tissue. Sympathetic innervation arises, for example, from the sympathetic chain ganglia, and the inferior mesenteric, hypogastric, and pelvic ganglia. As parasympathetic activation decreases after an erection, baseline sympathetic activity causes detumescence. Another potential
10 mechanism of tumescence is a sufficient decrease in baseline sympathetic activity, for example, during REM sleep.

 Normally, there is also voluntary and involuntary CNS and non-ANS (somatic) PNS nervous control exercised over erectile function, both to increase and decrease tumescence. Some CNS/somatic subsystems receive ANS input. For example, the spinal
15 cord cells of Onuf's nucleus (implicated, for example, in the control via the pudendal nerve of musculature involved in venous compression during tumescence) are anatomically linked with the sacral parasympathetic motorneurons. Sensory stimulation (for example, of the penile shaft) leads to signaling from peripheral nerves to the lower spinal cord, potentially resulting in increased parasympathetic activity.

20 In some embodiments, the following method, including one or more of the blocks in the shown order or in a different order, is suggested. The flowchart of *Figure 2* begins, and, in some embodiments, a SPECT (single photon emission computed tomography) or other ANS activity image of the pelvis and/or lower abdomen is obtained at block **210**, an anatomical imaging of the pelvis and/or lower abdomen is
25 acquired at block **212**, and the images are co-registered at block **214**, for example as described in relation to *Figure 8*, hereinbelow. It should be understood that combinations of blocks **210**, **212**, and/or **214** comprise one or more means—exemplary and non-limiting—by which sufficient data are gathered, in some embodiments, in order to enable the performance of operations described in relation to other blocks of the
30 flowchart.

 In some embodiments of the invention, activity imaging **210** is synchronized with respect to functional loads on a homeostatic organ system related to erectile

function. Optionally, imaging occurs within a period of, for example, erection (and/or lack of erection) in response to stimulation of the penis, a period of sleep (such as morning REM sleep) typically corresponding to nocturnal erection, and/or erection (and/or lack of erection) in response to erotic stimulation. In some embodiments of the invention, erectile function testing is accompanied by use of a drug having an effect on erection, for example, sildenafil, tadalafil, vardenafil, or another drug. Use of a drug which encourages and/or helps with the maintenance of an erection potentially partially allows imaging to be better correlated with epochs of ANS activity, for example by encouraging the ANS activity itself, and/or by helping to synchronize imaging with activity tending to produce tumescence. In some embodiments, tumescence and/or detumescence is controlled by electrical or magnetic stimulation, for example, transcutaneous and/or percutaneously.

At block **216**, in some embodiments, ANS activity data is evaluated for parameters including, for example, a parameter of one of the classes described in relation to block **316** of *Figure 3* hereinabove, changed as necessary to suit the anatomic and functional specifics of erectile function and its control, these being, for example, as described hereinabove. In some embodiments, a parameter is generated by comparison of activity images among ANS activation states, for example, among activation states described in relation to block **210**, hereinabove.

At block **218**, in some embodiments, a plan for treatment is formulated, for example in light of the ANS activity parameters evaluated at block **216**. Optionally, further information is used in formulating a treatment plan, for example, results of other evaluations including clinical history, clinical tests, genetic disease markers, and/or other imaging results.

A plan for treatment and/or further evaluation of erectile dysfunction is optionally developed based upon specific findings from the ANS imaging. Illustrative examples include the following:

In some embodiments of the invention, a finding of under-activity in a portion of the pudendal plexus involved in innervating the penis is made for a phase or aspect of erectile function, for example imaged as described hereinabove. For example, a model criterion is satisfied in which a pudendal plexus should be well-activated in at least one condition of activity imaging, but such activation is not observed. The phase or aspect

of erectile function is, for example, erection (or lack thereof) in response to stimulation of the penis, a period of sleep typically corresponding to nocturnal erection, a period following administration of an erection-enhancing drug, and/or erection in response to erotic stimulation. Optionally, the finding of under-activity is in another
5 parasympathetic pathway involved in the ANS innervation of the penis. Parasympathetic under-activation of the penis, associated with insufficient relaxation of the arterial smooth muscle that allows blood filling resulting in tumescence potentially prevents achieving tumescence.

In some embodiments of the invention, a plan is made to artificially stimulate an
10 under-active parasympathetic pathway, for example, a portion of the perineal nerve, with the goal of regaining useful erectile function. Optionally, the stimulation comprises transcutaneous electrical nerve stimulation (TENS). Optionally or alternatively, a percutaneous stimulating device is used. Optionally, the stimulation apparatus is applied and/or used within a defined period, for example, a period of planned sexual activity.

In some embodiments, innervation (particularly parasympathetic innervation) to
15 the smooth muscle fibers of the corpora cavernosa or to another innervation target related to erection is mapped by a stimulation procedure combined with recording of regions in which activity rises as a result of stimulation. In some embodiments of the invention, treatment comprises providing means for selectively stimulating regions
20 which result in an increase in activity relating to one or more erectile mechanisms. It is a potential advantage to use ANS mapping for determining an appropriate stimulating position, as it is possible that stimulation under exploratory conditions is too brief and/or not fully adequate to induce an erection (for example, it may be useful to assist in erection maintenance, but only if an erection already is present). Optionally, ANS
25 activity-guided stimulation is used to provide indications as to when a nerve or GP near to the intended target is stimulated. This provides a potential advantage over attempting to locate a nervous system structure “blindly”, and/or without functional feedback.

In some embodiments of the invention, a finding of over-activity in a portion of
30 the inferior mesenteric, hypogastric, and/or pelvic ganglia involved in sympathetic innervation of the penis is made for a phase or aspect of erectile function, for example imaged as described hereinabove. The phase or aspect of imaged erectile function is, for example, erection in response to stimulation of the penis, a period of sleep (such as

morning REM sleep) typically corresponding to nocturnal erection, administration of a drug, electrical or magnetic stimulus, and/or erection in response to erotic stimulation. Optionally or alternatively, the finding of over-activity is in another sympathetic pathway involved in the ANS innervation of the penis. Sympathetic over-activation in
5 innervation reaching the penis, associated with increased tone of the arterial smooth muscle of erectile tissue potentially prevents achieving tumescence.

In some embodiments of the invention, a plan is made to reduce activity of an over-active parasympathetic pathway, for example, a portion of an overactive ganglion, with the goal of regaining useful erectile function. Optionally, the stimulation comprises
10 partial ablation, for example, by heat, cooling, and/or chemical injection. Optionally, another form of nerve block is applied. Optionally, sympathetic nerve block is applied transiently, for example, preceding and/or within a period of planned sexual activity.

In some embodiments, similar to as described hereinabove with respect to parasympathetic stimulation, active-probing activity mapping is performed by
15 stimulation (optionally, by inhibition) of sympathetic innervation. Stimulation of the sympathetic innervation of the corpora cavernosa during stimulation mapping potentially has no obvious effects on the production of an erection (although a well-maintained erection is potentially detumesced by such activity). However, sympathetic stimulation of a nerve or GP which maps to the corpora cavernosa
20 potentially reveals a target for ablation, or for a more transient neuromodulatory block such as anesthesia.

At block **220**, in some embodiments, a planned therapy is delivered to a nervous system structure related to penile erection. The therapy is, for example, an ablation, or another activity-affecting therapy such as delivery of a drug or other bioactive material,
25 implantation of an inhibiting or stimulating bioactive material eluting device, implantation of a percutaneous electrical or magnetic field stimulating device, use of a transcutaneous electrical or magnetic field stimulating device, or another therapeutic intervention. In some embodiments, the administration of therapy is under the guidance of an ANSmap. For example, a specific region of a GP showing elevated activity in an
30 ANSmap is targeted, and a treatment probe guided to this region with specific (optionally, automated) reference to the targeted region.

At block **221**, in some embodiments, therapy results are monitored. In some embodiments, monitoring comprises re-imaging to verify that an intended effect of therapy on ANS activity actually occurred, and/or that no unintended effect occurred or is developing. In some embodiments, therapy is planned to be delivered in two or more stages, with monitoring at each stage to verify that intended effects are occurring, have reached a desired level, and/or that potential side-effects are tolerable.

At block **222**, in some embodiments, a decision is made as to whether or not a treatment intervention has reached a sufficient level of success to terminate therapy. Additionally or alternatively, the determination relates to whether or not additional intervention is unlikely to improve an outcome. If yes, the flowchart ends. Otherwise, in some embodiments, flow returns to an earlier operation, for example, block **210**.

Rheumatoid Arthritis

Reference is now made to *Figure 4*, which schematically shows a method of using a map of autonomic nervous system activity in the evaluation and/or therapeutic treatment of rheumatoid arthritis, according to some exemplary embodiments of the invention.

Rheumatoid arthritis (RA) and the immune system. RA is a disease of the immune system which leads to effects such as chronic inflammatory response of the joints. In some patients, another organ is affected, such as the lungs, pleura, pericardium, sclera, kidney, and/or heart.

ANS involvement in immune system regulation and RA. Neuroanatomical studies have demonstrated that all primary and secondary immune organs (for example, the thymus, spleen, lymph nodes, and bone marrow) receive innervation from sympathetic postganglionic neurons. Sympathetic activity is considered an exciter of at least the acquired/adaptive immune system. Parasympathetic activity appears to be implicated in inhibition of the immune system. Immune system activation, though needed to defend against infectious invasion, is “expensive” for an organism, for example, in terms of energy expenditure. Potentially, mismatched regulation of its activation or inhibition leads disease production by causing the immune system to dwell in one of these extremes, or by another mechanism, for example as outlined hereinbelow. Over-activation of the sympathetic system potentially causes or potentiates the inflammatory response of RA. Additionally or alternatively, insufficient inhibition of

inflammatory responses by the parasympathetic system potentially allows RA inflammatory responses to go unchecked. Potentially, redistribution of sympathetic innervation leads to RA inflammation. For example, partial ablation of splenic innervation may stimulate regrowth which does not reform the original innervation pattern. Instead, one or more regions become overstimulated, while a denervated region remains understimulated. Potentially, the two regions should normally work together to form a balanced immune response (for example, one free of autoimmune effects). When one becomes overstimulated, the balance is lost. Additionally or alternatively, the overstimulated region simply becomes unregulated in its production of immune response cells, leading to autoimmune disorder such as RA.

In some embodiments, the following method, including one or more of the blocks in the shown order or in a different order, is suggested. The flowchart of *Figure 4* begins, and, in some embodiments, a SPECT (single photon emission computed tomography) or other ANS activity image of the abdomen, optionally including the spleen, is obtained at block **410**, an anatomical imaging of the abdomen is acquired at block **412**, and the images are co-registered at block **414**, for example as described in relation to *Figure 8*, hereinbelow. In some embodiments, activity region and/or anatomical images associated with one or more joints affected by RA is obtained. It should be understood that combinations of blocks **410**, **412**, and/or **414** comprise one or more means—exemplary and non-limiting—by which sufficient data are gathered, in some embodiments, in order to enable the performance of operations described in relation to other blocks of the flowchart.

It should be understood another or a different target is potentially imaged in some embodiments of the invention. For example, the control system of T cell maturation in the spleen is mediated via ganglia in the celiac plexus. As was discussed in relation to diabetes, the area of imaging is potentially wider or narrower than a system which is potentially to be targeted for treatment. Potentially, it is even moved entirely, insofar as neural control networks have ganglia or other control structures located remotely from innervated targets. As described, for example, in relation to glucose sensing, the network structure of ANS control causes an optimal site of imaging and/or treatment to a site remote from an organ to be ultimately affected.

In some embodiments of the invention, activity imaging **410** is synchronized with respect to functional loads on a homeostatic organ system related to immune function. Stress, for example, is an activator of sympathetic system, and is a potential condition of imaging for comparison to a resting state of sympathetic activity.

5 At block **416**, in some embodiments, ANS activity data is evaluated for parameters including, for example, a parameter of one of the classes described in relation to block **316** of *Figure 3* hereinabove, changed as necessary to suit the anatomic and functional specifics of immune function and its control. In some embodiments, a parameter is generated by comparison of activity images among ANS activation states, 10 for example, among activation states described in relation to block **410**, hereinabove.

At block **418**, in some embodiments, a plan for treatment is formulated, for example in light of the ANS activity parameters evaluated at block **416**. Optionally, further information is used in formulating a treatment plan, for example, results of other evaluations including clinical history, clinical tests, genetic disease markers, and/or 15 other imaging results.

A plan for treatment and/or further evaluation of immune regulatory dysfunction is optionally developed based upon specific findings from the ANS imaging. For example, parasympathetic innervation at or near a site of RA inflammation is imaged. Potentially, a lack of strong activity reflects insufficient parasympathetic innervation, 20 relative to a level of immune activation. A potential treatment is to induce stimulation in parasympathetic ganglia innervating the affected area.

Additionally or alternatively, there is a potential oversupply of sympathetic innervation, for example, to one or more of the sites of immune cell production in the body such as the spleen, or a portion thereof. Optionally, sympathetic innervation is 25 reduced in an overactive region, potentially reducing the supply of overactive immune cells as well, and/or rebalancing production of cells from an overactive region with those of other regions, which may serve a role in further regulation of the immune cell response.

At block **420**, in some embodiments, a planned therapy is delivered to a nervous 30 system structure related to the immune system and/or RA activity. The therapy is, for example, an ablation, or another activity-affecting therapy such as delivery of a drug or other bioactive material, implantation of an inhibiting or stimulating bioactive material

eluting device, implantation of a percutaneous electrical or magnetic field stimulating device, use of a transcutaneous electrical or magnetic field stimulating device, or another therapeutic intervention. In some embodiments, the administration of therapy is under the guidance of an ANSmap. For example, a specific region of a GP showing elevated activity in an ANSmap is targeted, and a treatment probe guided to this region with specific (optionally, automated) reference to the targeted region.

At block **421**, in some embodiments, therapy results are monitored. In some embodiments, monitoring comprises re-imaging to verify that an intended effect of therapy on ANS activity actually occurred, and/or that no unintended effect occurred or is developing. In some embodiments, therapy is planned to be delivered in two or more stages, with monitoring at each stage to verify that intended effects are occurring, have reached a desired level, and/or that potential side-effects are tolerable.

At block **422**, in some embodiments, a decision is made as to whether or not a treatment intervention has reached a sufficient level of success to terminate therapy. Additionally or alternatively, the determination relates to whether or not additional intervention is unlikely to improve an outcome. If yes, the flowchart ends. Otherwise, in some embodiments, flow returns to an earlier operation, for example, block **410**.

Irritable bowel syndrome

Reference is now made to *Figure 5*, which schematically shows a method of using a map of autonomic nervous system activity in the evaluation and/or therapeutic treatment of irritable bowel syndrome, according to some exemplary embodiments of the invention.

The cause of IBS is unknown, and diagnosis is potentially a matter of ruling out other illnesses. Optionally, IBS is related to stress. Optionally, as suggested by previous research, IBS symptoms are associated with the sympathetic nervous system firing constantly, for example due to injury of the meninges.

In some embodiments, the following method, including one or more of the blocks in the shown order or in a different order, is suggested. The flowchart of *Figure 5* begins, and, in some embodiments, a SPECT (single photon emission computed tomography) or other ANS activity image of the abdomen is obtained at block **430**, an anatomical imaging of the abdomen is acquired at block **432**, and the images are co-registered at block **434**, for example as described in relation to *Figure 8*,

hereinbelow. It should be understood that combinations of blocks **430**, **432**, and/or **434** comprise one or more means—exemplary and non-limiting—by which sufficient data are gathered, in some embodiments, to enable the performance of operations described in relation to other blocks of the flowchart.

5 In some embodiments of the invention, activity imaging **430** is synchronized with respect to functional loads on a homeostatic organ system related to immune function. Stress, for example, is an activator of the sympathetic system, and any applied stress condition is a potential condition of imaging for comparison to a resting state of sympathetic activity.

10 At block **436**, in some embodiments, ANS activity data is evaluated for parameters including, for example, a parameter of one of the classes described in relation to block **316** of *Figure 3* hereinabove, changed as necessary to suit the anatomic and functional specifics of bowel function and its control. In some embodiments, a parameter is generated by comparison of activity images among ANS activation states,
15 for example, among activation states described in relation to block **430**, hereinabove.

 At block **438**, in some embodiments, a plan for treatment is formulated, for example in light of the ANS activity parameters evaluated at block **436**. Optionally, further information is used in formulating a treatment plan, for example, results of other evaluations including clinical history, clinical tests, genetic disease markers, and/or
20 other imaging results.

 A plan for treatment and/or further evaluation of irritable bowel syndrome is optionally developed based upon specific findings from the ANS imaging. For example, there is a potential oversupply and/or overactivation of sympathetic innervation, for example, to one or more of the sites along the bowel. Optionally, sympathetic
25 innervation is reduced in an overactive region. Potentially, this serves to rebalance sympathetic and parasympathetic innervation in a region which can be particularly selected from among possible candidate regions, due to the guidance by imaging results.

 At block **440**, in some embodiments, a planned therapy is delivered to a nervous system structure related to innervation of the bowel. The therapy is, for example, an
30 ablation, or another activity-affecting therapy such as delivery of a drug or other bioactive material, implantation of an inhibiting or stimulating bioactive material eluting device, implantation of a percutaneous electrical or magnetic field stimulating

device, use of a transcutaneous electrical or magnetic field stimulating device, or another therapeutic intervention. In some embodiments, the administration of therapy is under the guidance of an ANSmap. For example, a specific region of a GP showing elevated activity in an ANSmap is targeted, and a treatment probe guided to this region with specific (optionally, automated) reference to the targeted region.

At block **441**, in some embodiments, therapy results are monitored. In some embodiments, monitoring comprises re-imaging to verify that an intended effect of therapy on ANS activity actually occurred, and/or that no unintended effect occurred or is developing. In some embodiments, therapy is planned to be delivered in two or more stages, with monitoring at each stage to verify that intended effects are occurring, have reached a desired level, and/or that potential side-effects are tolerable.

At block **442**, in some embodiments, a decision is made as to whether or not a treatment intervention has reached a sufficient level of success to terminate therapy. Additionally or alternatively, the determination relates to whether or not additional intervention is unlikely to improve an outcome. If yes, the flowchart ends. Otherwise, in some embodiments, flow returns to an earlier operation, for example, block **430**.

ANS Hyperactivity and Hypoactivity

Hyperactivity of ANS

In some embodiments, the invention is applied to a condition associated with hyperactivity of the ANS. In some embodiments, sympathetic and/or parasympathetic activity are determined, adjusted, and/or re-determined to evaluate disease prognosis and/or treatment outcome. Diseases potentially involving ANS hyperactivity include, for example, the following.

Thyrotoxicosis: Induced, for example, by an infectious (viral or bacterial) trigger of an unknown idiopathic mechanism. Potentially, increased sympathetic tone increases thyroid hormone release, end-organ sensitivity and/or decreases the rate of conversion of T4 to rT3 (a non-active metabolite of thyroid hormone). In embodiments where sympathetic and parasympathetic tone are adjusted, it is a potential advantage to reduce thyroid-innervating sympathetic tone and/or increase parasympathetic tone, to reduce these effects.

Autoimmune disease: Induced, for example, when stress in any form triggers an exacerbation of an autoimmune attack. Potentially, activation of T lymphocytes relates

to overstimulation of the sympathetic system. Potentially, the release of interferon, interleukins and/or certain cytokines is affected by ANS. In some embodiments where ANS activity is adjusted, innervating activity reaching the spleen and/or lymph nodes is adjusted. The spleen and lymph nodes comprise major organs for the maturation of T lymphocytes, are an optional target and are potentially affected by alterations in ANS tone.

Optionally, as suggested by Stojanovich (Stojanovich L and Marisavljevic D; Stress as a trigger of autoimmune disease. *Autoimmun Rev.* 2008 Jan;7(3):209–213), physical and psychological stress has been implicated in the development of autoimmune disease.

Irritable bowel disease (IBD): Stress and stress response, associated with the ANS, are associated with IBD. For example, IBD is potentially exacerbated by stress. Furthermore, ANS input to the GI tract is well known. Potentially, symptoms of IBD and IBS can be elicited by changes in ANS function. For example, gastrointestinal motility and/or intestinal absorption are functions potentially affected by ANS activity.

Diabetes: Many organs and body system components affect glucose metabolism, either directly or indirectly. Examples include the liver and the pancreas, respectively. Potentially, these organs change their function in response to an ANS signal. In some embodiments of the invention, organ function is changed by sympathetic stimulation such that blood glucose is elevated and/or insulin production is inhibited. In some embodiments, one or more duodenal functions are modulated by modulation of the ANS. A modulated function is, for example, an endocrine, exocrine and/or absorption function.

As suggested by Surwit (Surwit RS and Feinglos MN; Stress and Autonomic Nervous System in Type II Diabetes, A Hypothesis; *Diabetes Care* 1988 11), the sympathetic nervous system is involved in the pathophysiology of type II (noninsulin-dependent) diabetes mellitus.

Hypertension: Control of blood pressure potentially relates to ANS activity. In some embodiments, ANS mapping is used to identify cases of hypertension where over-activity of the ANS is a cause of hypertension. In some embodiments, ANS mapping is used to depict the ANS reaction to elevated blood pressure caused by another reason, for example, iatrogenic volume overload.

Hypertrophic cardiomyopathy: optionally, in this condition, part or all the myocardial tissue undergoes hypertrophy. The cause may be unknown, and in some cases can be the result of a primary disease, for example of the muscle. Optionally, hypertrophy is caused by overstimulation of an organ by the ANS. In some cases, the disease affects only part of the heart such as in the case of Hypertrophic Obstructive Cardiomyopathy. The reasons for non-uniform myocardial hypertrophy can be multiple, and include local disease—for example, viral disease, and/or a compensatory ANS response that is trying to drive the contractile force back up by inducing local hypertrophy. Local hypertrophy potentially causes partial obstruction of the outflow tract of the ventricles of the heart, increasing the effort the myocardium has to perform to pump sufficient amounts of blood. In response, the ANS will increase its tone to further force the myocardium to deliver the needed amount of output. This cycle can potentially lead to eventual non-reversible damage to the myocardium.

Reference is now made to *Figure 6*, which comprises an ANSmap image **500** for a patient with sigmoid septum and cardiomyopathy, according to some exemplary embodiments of the invention.

The ANSmap clearly identifies increased sympathetic activity in the intra-ventricular septum **504**, compared to the adjacent tissue of the heart wall **502**. As discussed hereinabove, increased activity is potentially related to over-activation of the ANS in response to the primary pathology, and/or over-activation itself comprises a direct or primary cause of the pathology.

It is known in the art that an event of non-ischemic cardiomyopathy potentially relates to significant MIBG heart activity (measured as the ratio H/M—Heart to Mediastinum).

Deposition disease: Deposition disease includes, for example, amyloidosis. Deposition disease occurs, for example, in the context of chemical reaction through which a compound (for example, a mis-folded protein) is degraded, one of the degradation products being resistant to further degradation; optionally particularly resistant if stabilized in aggregating concentrations.

Reference is now made to *Figure 7*, which illustrates an exemplary deposition pathway **600**, according to some exemplary embodiments of the invention.

At block **602**, compound A is targeted for degradation, for example by a proteolytic enzyme. It is broken down into compounds B and C (blocks **604** and **606**, respectively). Compound B, in turn, is directly and/or indirectly degraded into one or more final degradation products D, at block **608**, the degradation products D being susceptible of reuse and/or elimination from the body. However, compound C is resistant to degradation and/or elimination, potentially giving rise to accumulation in the body leading to a disease state. In particular, in some embodiments, the resistance of compound C to degradation increases as its concentration increases, due for example, to hydrophobicity resulting in preferential self-aggregation, binding-up of stabilizing compounds, and/or another mechanism.

Potentially, the enzymatic reactions leading to production of molecule C is under at least partial regulation by the ANS. Thus, for example, over-activation caused by the ANS in which the rate of compound A degradation increases (this could be an indirect effect of overproduction of compound A) generates more of compound C. Potentially, the concentration of compound C is also raised. It is a potential advantage to reduce of the production and/or degradation of compound A by adjusting the ANS activation which causes it.

Additionally or alternatively, a build-up of compound B potentially reduces a rate of degradation of compound A, for example, by mass action and/or molecular regulatory effects within the machinery of the cell. If, for example, such a catalysis pathway between B and D is under ANS influence, then slowing a rate of breakdown of compound B by adjustment of ANS activity potentially has a secondary effect of reducing the deposition of compound C.

In some embodiments of the invention, ablation or stimulation specific to an ANS structure involved in one or more of the above diseases is performed, for example according to principles outlined in the overview, and/or in relation to *Figures 1-5* hereinabove.

Hypoactivity of the ANS

The following are examples of conditions associated with hypoactivity of the ANS, which some embodiments of the invention apply to:

- A. Syncope
- B. Hypothyroidism

- C. Idiopathic heart failure
- D. Asthma
- E. Deposition disease—ineffective metabolism—amyloidosis
- F. IBS
- 5 G. Weight gain

In some embodiments of the invention, ablation or stimulation specific to an ANS structure involved in one or more of the above diseases is performed, for example according to principles outlined in the overview, and/or in relation to *Figures 1-5* hereinabove.

10 **Localization of ANS pathology**

In some cases, disturbances of the ANS are generalized, and in some cases disturbances are localized—depending, for example, on the type of disease and/or its stage. Potentially, intermediate levels of generalization of ANS disturbance occur. Level of generalization is, for example, with respect to the extent of a region affected
15 (innervated), with respect to the extent of derangement of ANS tissue, and/or with respect to the extent of the centrality of deranged ANS tissue within the functioning of the system.

Deposition disease: In some deposition diseases, for example, increased or decreased ANS tone is associated with a defined region of innervated tissue. Optionally,
20 this causes a local deposition or a local depletion of a substance at said defined region.

Heart disease: In examples of localized effects in relation to heart disease, over-activity of the ANS potentially appears as local tissue hypertrophy, local alteration in electrophysiological properties (such as local refractoriness and/or conduction velocity) and/or local alteration in tissue properties (such as levels of Connexin 43 and
25 types of actin and myosin iso-enzymes).

In some cases, impairment of the ANS and/or of the tissue innervated takes a form which potentially ranges from the well-localized, to more global. Potentially, the site of symptoms is remote from a site of control and/or innervation which is subject to imbalance and/or derangement of function.

30 *Hyperhidrosis:* Hyperhidrosis is a potential exemplar of this. The level of disturbance in hyperhidrosis potentially varies according to patient and/or disease stage. Potentially, hyperhidrosis affects, for example, a palm of a hand, the entire arm, both

arms, and/or the entire upper trunk. In some embodiments, the ANSmap is used to diagnose a level of the causative mechanism of hyperhidrosis, and/or as a road map for guiding therapy.

In some embodiments of the invention, ablation or stimulation specific to an ANS structure involved in one or more of the above diseases is performed, for example according to principles outlined in the overview, and/or in relation to *Figures 1-5* hereinabove.

Other examples of ANS-related disease

Optionally, some ANS disorders relate to the sources of the ANS system (brain nuclei), while some relate to the pathway or to the ganglia. Optionally, the functioning of end-organ synapses of the ANS is critical for the ANS control function. Optionally, the functioning of the synapses depends on the nervous component of the junction and/or the receptor function on the target cell. Dysfunction of the ANS function may emanate from ANS receptor issue that affects the responsiveness of the organs to the ANS input. The ANS mapping system, as described in some embodiments of the invention, measures the response function of the ANS. Optionally, the total function of the ANS, for example from the origin to the response of the function unit is assessed. Optionally, the map is positive. Optionally, there is no end-organ response to the ANS. Optionally, in such a case, the end-organ response is diagnosed by the mapping.

Obesity: In some cases of certain medical conditions such as obesity or morbid obesity, weight gain may follow blockade of the sympathetic nervous system input to the tissue.

COPD: Another example is the case of Chronic Obstructive Pulmonary Disease (COPD). The patients in this disease are subject to certain stimuli (smoke or other pollutant). Only certain patients (currently called “susceptible patients”) may develop the disease, while the rest of the patients do not develop the disease. The inventors postulate that different ANS response to the stimuli is the cause for developing the disease. This postulation is based on multiple observations that COPD patients have different level of activation of the ANS (both locally in the lungs and generally). These finding of altered ANS activity in COPD patients can be part of the primary mechanism of the disease, and/or a response to the pathology brought by the disease. Optionally, detecting the ANS status assists in diagnosing and/or treating the patient.

Some embodiments relate to diagnosing a disease based on ANS mapping showing activity of part of an organ and/or system component relative to another part of the same organ/system component and/or a different organ/system component. Some examples include:

- 5 • *Torticollis*: contraction of ipsilateral sternocleidomastoid muscle in the neck—often treated by local injection of botulinum toxin into to the over- contracted muscle
- *Hypertrophic cardiomyopathy*
- *Idiopathic dilated cardiomyopathy*
- 10 • *Right Ventricular Outflow Tachycardia*
- *Brugada syndrome*
- *Tetralogy of Fallot, after repair*
- *Cardiomyopathies*: generalized/localized due to pacing
- *Hypertrophic obstructive cardiomyopathy*
- 15 • *Deposition disease of lungs*
- *Sleep apnea*: delay in autonomic activity, chemo- and baroreceptors change sensitivity
- *Asthma*: hyperactivity of airways
- *liver disease*: metabolic derangement of the liver related to the activity of the
- 20 ANS
- *Hyperhidrosis*
- *Salivation*
- *Lacrimation*

Relating to treatment, sympathectomies as therapy were practiced over 50
25 years ago for many disease states. Generally they were used in severely sick patients, using a surgical procedure. The common indication was malignant hypertension. The surgical approach affected many organs and had many side effects. More specific surgical ANS interventions were developed over the years to include therapy for peptic ulcer, for hyperhidrosis, for vascular disease, some type of psychiatric disease and
30 others.

In some embodiments of the invention, ablation or stimulation specific to an ANS structure involved in one or more of the above diseases is performed, for example

according to principles outlined in the overview, and/or in relation to *Figures 1-5* hereinabove.

Guidance of Therapy and/or Diagnosis

Currently, ANS modification is well practiced. It is applied to multiple
5 conditions using multiple approaches. Some of the approaches relate to surgical interventions while other interventions call on using pharmacologic interventions. The benefit of certain surgical procedures is a localized and specific effect—some effects are achieved over an organ or set of organs, while some relate more directly to the sympathetic or to the parasympathetic systems.

10 Common to focused interventions is the lack of ability to guide to the procedure by identifying the target in a noninvasive way.

Current procedures either use an open approach (where the surgeon exposes the organ and identifies a large nerve trunk or large ganglia and resects them, or in a minimally invasive approach, where operators are using surrogate information to guide
15 themselves to the most likely area in proximity of the nerve or ganglia to be treated. These approaches are by far less accurate, carry significant risk, less specific and hard to monitor and improve. The current invention of ANS mapping may modify this field, for example by enabling the operator to navigate on top of a function (neurotransmitter marker) road map. Optionally, the operator can achieve safe, accurate, highly
20 reproducible treatment of any target by tracking specific neuro-activity. Optionally, in some embodiments, the operator will be able to monitor the success of his therapy.

These are some examples of ANS intervention procedures known in the art. Optionally, by incorporating ANSmap, the safety and/or efficacy of these conditions may improve.

- 25 • Stellate gangliotomy (anatomy guided procedure). The stellate ganglion receives input from the paravertebral sympathetic chain and provides sympathetic efferent to the upper extremities, head, neck, and heart.
- GP ablation for the treatment of atrial fibrillation (HFS guided therapy)
- Vagotomy for peptic ulcer disease.
- 30 • Sympathectomy for burger and peripheral vascular disease.
- ANS treatment for the treatment of severe anxiety and social phobia.

In some embodiments, the ANSmap may be used for one or more of the following examples:

- Measuring absolute level of activity on an organ part of an organ, and/or system component
- 5 • Measuring the response to a stimuli of the ANS activity
- Measuring the relative activity in the same organ and/or a different organ
- detecting locations within the organ
- detecting time through the day or month
- Measuring the response to therapy
- 10 • Monitoring the patient
- assessing the Stage the disease
- Diagnosing a disease
- Identifying the cause of disease
- Evaluating potential therapies

15 Such therapies can include:

- Ablation of part of segments of the ANS
- Ablation of certain path innervating contralateral regions (the “normal” region—
in case the ANS response is in response to certain conditions that can be
improved by abolishing the ANS input to the other sites in the body (as an
20 example—an infarct induced cardiomyopathy. In this case the disease and the
progression of cardiac failure is caused by ANS over stimulation of the normal
tissue adjacent to the damaged myocardium. Optionally, the ANS
over-stimulation is so intense such that it leads to lethal arrhythmias (therefore,
in such a case, the denervation of the ANS from the “normal” region will be the
25 therapy of choice).

In cases where the ANS over-stimulation is the disease itself, for example in the case of rheumatoid arthritis: one can postulate that ANS over-stimulation of the Spleen accelerating the rate of formation of certain killer T cells and the “aggressive” behavior these T cell adopt. The therapy in this case will be applied to denervate the spleen from
30 the ANS.

Optionally, by mapping the ANS, the treatment can be modified accordingly, for example by disconnecting, pacing and/or stimulating the modulation.

ANS Mapping

Reference is now made to *Figure 8* which is a flow chart of a method for processing functional images to identify and/or locate one or more ANS components (such as ganglia), according to some exemplary embodiments of the invention.

5 A branch of the flowchart of *Figure 8* begins, and in some embodiments of the invention, at block **352**, functional imaging modality data and/or images are received.

The data and/or images comprise, for example, a D-SPECT image and/or other images. Received images, in some embodiments, are of a body part; for example: a torso, abdomen, heart, or another body part, according to the scanning protocol selected.

10 The body part, in some embodiments, includes nervous system tissue to be imaged, and/or the innervated organ itself. For example, nerve tissue comprises GPs of the heart, intestines and/or another organ. Optionally, the functional images include regions of activity that denote nerve tissue such as a GP made detectable, for example, by uptake of a radiotracer such as mIBG. In some embodiments, a two tracers are used; for

15 example, first tracer such as mIBG to label activity, and a second tracer to image tissue vitality.

Optionally, functional data is collected from a body part that has regions where nerve activity is expected, and regions where nerve activity is not expected. For example, during imaging of the heart, data denoting nerve activity is expected from the

20 heart wall and/or surrounding tissues, and no nerve activity is expected from inside the blood-filled hollow chambers. Potentially, noise is received from areas corresponding to the inside of the heart chamber, though no true activity is expected. Optionally, the noise is removed from the functional data based on the corresponding anatomical image; for example, after image registration. Optionally, intensity denoting noise within blood- or

25 other fluid-filled chambers and/or vessels is removed. For example, intensity readings of the functional data corresponding to heart chambers and/or surrounding blood vessels are removed by applying one or more image mask on functional image. In some embodiments, fluid-filled chamber noise is used in obtaining a noise estimate applicable to other tissue locations.

30 In some embodiments of the invention, information with regard to the autonomic nervous system is obtained by measuring surrogate functions that relate to the autonomic nervous system. Surrogate measurements include for example, blood levels

of neurotransmitter used by the autonomic nervous system, electrical activity of nerve fibers or ganglia, temperature of the ganglia, and/or responses tied to similar autonomic nervous system inputs (for example, heart rate or blood vessel resistance). It should be appreciated, however, that the quality of surrogate measures of the autonomic nervous system is potentially lower than that of direct measures of autonomic nervous system activity. More specifically, surrogate measures of the autonomic nervous system preferably have certain qualities to qualify as useful in some embodiments of this invention. In particular, a measure preferably conveys site specificity, and has the ability to generate a valid signal through a dynamic range of health and disease.

In some embodiments of the invention, at block **354**, an anatomical region is extracted from the image. Optionally, tissue image regions (potentially containing nerve structures) are segmented from hollow spaces (non-innervated, but potentially containing fluid). For example, the wall of the left ventricle (LV) and/or the hollow space within the LV is extracted. Optionally, the extracted region is a layer of tissue, such as the tissue layers forming the LV wall, instead of, for example, the LV including the hollow chamber inside the LV. In exemplary cases of kidney imaging, the walls of the renal artery are extracted and/or the inside of the artery is extracted. When imaging other organs, dominant portions of the organ are optionally selected.

In some embodiments of the invention, at block **356**, one or more registration cues are extracted from the image. Potential sources of registration cues include, for example, the organ of interest, and/or surrounding anatomical structures. Particular examples include the LV axis, liver, heart septum, RV, and/or torso. Optionally, registration cues are used to match anatomical images with functional images, and/or to match anatomical images during a physiological cycle, such as the cardiac cycle.

Another branch of the flowchart of *Figure 8* begins, and in some embodiments of the invention, at block **358**, anatomical image modality data and/or images are received. Anatomical image modality data comprises data obtained, for example, from a CT, MRI, 3D ultrasound, 2D ultrasound, fluoroscope, or by another modality. The anatomical image denotes the structure of the tissue and/or organ innervated by nerve tissue, such as a GP. The anatomical image denotes the tissue and/or organ structure corresponding to the location of nerve tissue such as a GP. The anatomical images, in some embodiments, contain both the nerve tissue to be functionally imaged and the

innervated organ. Alternatively, anatomical data is received that is not personalized to the patient, for example, from a general anatomical model.

Optionally, anatomical data from an anatomical imaging modality is received to reconstruct an anatomical image of a region of a body of a patient. Optionally, the
5 region comprises a portion of at least one internal body part which borders on a target nerve tissue.

The anatomical images and the functional images denote corresponding regions of the body containing the GPs for identification and/or localization. For example, both modalities are employable to take pictures of the heart, kidney, or other organs. To
10 image GPs of the heart, for example, anatomical and/or functional images of the heart are obtained. To image GPs of the kidney, in another example, anatomical and/or functional images of the kidney, renal artery and/or aorta are obtained.

In some embodiments of the invention, at block **360**, images corresponding to different times during a dynamic cycle are optionally extracted and/or acquired. For
15 example, for the heart, images are extracted along the cardiac cycle. Periods selectable along the cardiac cycle for extraction include, for example, the end diastolic volume (EDV) and/or the end systolic volume (ESV). In another example: for the bladder, images are optionally extracted corresponding to a full bladder and an emptying bladder.

In some embodiments, the average image is computed, for example, as
20 $(EDV+ESV)/2$.

In some embodiments of the invention, at block **362**, one or more images are segmented. Segmentation, in some embodiments, is fully automatic. In some
25 embodiments, segmentation requires or potentially involves manual user intervention.

In some embodiments of the invention, at block **364**, an anatomical region is extracted. Optionally, the anatomical region corresponds to the anatomical region
extracted at block **354**. Optionally, the anatomical region is extracted from the segmented image of block **362**.

In some embodiments of the invention, at block **366**, one or more registration
30 cues are extracted from the image. Potential sources of registration cues include, for example, the organ of interest, and/or surrounding anatomical structures. Particular examples include the LV axis, liver, heart septum, RV, and/or torso.

The branches of the flowchart merge, and in some embodiments of the invention, at block **368**, the functional images or data and the anatomical images or data are registered. Optionally, the images are registered based on alignment of the extracted anatomical regions of blocks **354** and **364**. Registration is performed manually,
5 automatically and/or semi-automatically.

Optionally, registration takes into account organ dynamics, for example, heart movement. As examples: anatomical images during the dynamic cycle are registered, and/or functional data are corrected for the dynamic movement. As a particular example: intensity readings within the heart chamber are corrected to association with
10 nearby moving heart wall.

In some embodiments of the invention, at block **370**, image masks are generated based on the anatomical image and/or data. Optionally, the image masks direct processing and/or visual display of the nerve tissue to specific locations of the image located within the image masks. For example: GPs are displayed and/or processed
15 within the volume of an applied image mask, GPs outside the volume of the image mask are not processed and/or displayed, and/or GPs outside the volume of the image mask are processed and/or displayed differently than those GPs inside the image mask.

Optionally, the anatomical images are processed to generate the image mask corresponding to dimensions of at least one internal body part, for example, the walls of
20 the chambers of the heart. For example, a dimension of an internal body part of the specific patient is calculated and used to define the mask.

Optionally, the image masks are selected and/or defined for tissue surrounding a hollow chamber. As examples, image masks are defined based on:

- the shape of the heart chamber walls, excluding the hollow region within the
25 chambers;
- the arterial wall, excluding the hollow region within the artery; or
- the shape of the bladder, excluding the hollow region within the bladder.

It is noted that nerve structures are potentially confined within the tissues defined by the image masks. The hollow spaces (potentially filled with fluid such as
30 blood, urine or other fluids) are expected to be nerve structure free. Optionally, image masks include tissue surrounding the organ of interest.

The image masks are defined, for example, based on:

- image segmentation—such as according to the ability of the system to segment the image;
 - tissue type—such as muscle vs. connective tissue;
 - organ size;
 - 5 • sub-structures within the organ—such as heart chambers, liver lobes, or kidney parts;
- or another method.

Different image masks are optionally generated for different tissue types, and/or for GPs at different locations within the organ. For example, for each of the GPs within the epicardium and myocardium, a respective set of image masks is generated. 10 Optionally, image masks are generated for fat pads.

The image mask comprises, for example, a 2-D surface and/or 3-D volume with shape and/or size selected based on tissues and/or organ parts within the anatomical image. The image mask optionally corresponds to anatomical parts believed to contain the neural tissue for imaging, such as GPs. For example, the mask corresponds to the: 15 walls of the four heart chambers, intestinal wall, bladder wall, renal artery, aortic branch region of the renal artery, kidney, and/or another structure. In more particular examples, the image mask is generated to contain GPs within the epicardial and/or myocardial tissue of the heart, or kidney innervating GPs at the aorta-renal artery junction.

20 Optionally, image masks are generated based on an estimated location of the GPs. For example, an estimated location is based on normal patient anatomy, an initial model of the ANS for a patient, and/or known previous ablation or other medical data, such as indications of missing or ablated nervous tissue. Optionally, image masks are generated based on an estimated location of the GPs and dimensions of an internal body 25 part inferred, for example, from an anatomical image. Potentially, this provides an advantage when GPs are not visible on the anatomical image.

Optionally, generated image masks correspond to the segments of the anatomical image. For example, the heart is segmented into chamber walls and the generated image masks correspond to the chamber walls of interest.

30 In some embodiments of the invention, at block **372**, the image masks are applied to the functional image. Alternatively or additionally, the image masks are applied to the functional data. Alternatively or additionally, the image masks are applied

to combined functional and anatomical images and/or data, for example, overlaid images.

Optionally, the image masks are applied based on the registration process (block **368**). The anatomical information serves as a guide, using the selected image masks, for selective reconstruction of GP related data within the functional image. The image masks may be correlated with the image to contain anatomical structures having the neural tissues. The application may be based on the image registration, for example, applied based on a common coordinate system. The image masks may be applied to a certain type of tissue containing neural tissue. For example, the image masks may be applied to the epicardium of the heart. The image mask may be applied to have its inner surface aligned with the epicardial surface of the chamber wall, such that the image mask contains the epicardial space encompassing the chamber.

Optionally, the generated image mask is correlated with the functional data for guiding the reconstruction of a functional image depicting the target nerve tissue.

In some embodiments of the invention, at block **374**, functional activity is calculated within the applied image mask space. Optionally, the average functional activity is calculated. Optionally, the standard deviation of the functional activity is calculated. For the heart example, the functional activity is calculated around each chamber separately, and around the entire heart. Average activity for the chambers may be denoted by A1LV, A1RV, A1LA, and A1RA. Average activity for the heart may be denoted by A1H. Standard deviation of the activity may be denoted by SD1LV, SD1RV, SD1LA, SD1RA, and SD1H. Optionally, average activity and/or standard deviation may be calculated for the entire functional image or data. Optionally, average activity and/or standard deviation is pre-set, e.g., based on previous imaging of the same patient, based on “normal” patient activity etc.

In some embodiments of the invention, at block **378**, GPs are identified within the applied image mask space. It should be noted that the term “GP” is used for ease of discussion, and that the method is optionally applied in some embodiments for identifying ANS component(s) or for extracting or identifying other information relating to neural activities, or other tissues. Alternatively or additionally, GPs are identified within the organ volume and/or nearby tissues. Optionally, GPs identified within multiple different image masks that are combined into a single image of all the

identified GPs, for example, the identified GPs within the organ. Alternatively or additionally, GPs identified within corresponding image masks of multiple frames over time are combined—such as all image masks of the LV myocardium during the cardiac cycle.

5 Optionally, areas of extreme activity are identified. For example, epicardial GPs (EGP) and/or myocardial GPs (MGP) are identified based on extreme mIBG activity.

 Optionally, GPs are identified based on one or more predefined thresholds and/or rules. Optionally, GPs are identified based on size. Alternatively or additionally, GPs are identified based on activity level in reference to average activity and/or
10 surrounding activity. Alternatively or additionally, GPs are identified based on connectivity between GPs.

 In some embodiments, the GP is identified as an object within a particular size constraint. The constraint is, for example, at least about 4x4x4 mm, such as for an EGP; or about 2x2x2 mm, such as for an MGP. Alternatively or additionally, the GP is
15 identified by comparing calculated activity (image intensity) of a certain region to surrounding activity in the same image mask. Alternatively or additionally, the GP is identified by comparing calculated activity within the image mask to activity in another image mask. For example, the EGP is identified as satisfying the rule that the total activity of the EGP is a predefined factor times the standard deviation (SD1 and/or
20 SD2), above average activity (A1 and/or A2), and/or the adjacent activity surrounding it is lower than half of the EGP activity. Optionally, activity is corrected for volume. Optionally, the user selects and/or modifies the predefined factor. For example, the MGP is identified as satisfying the rule that the total activity of the MGP is another predefined factor times the standard deviation (SD1 and/or SD2), above average activity
25 (A1 and/or A2), and/or the adjacent activity surrounding it is lower than half of the MGP activity, optionally corrected for volume. Optionally, the user selects and/or modifies the predefined factor.

 Optionally, identification of GPs is performed per frame, optionally per frame of the dynamic cycle (e.g., cardiac cycle).

30 In some embodiments, the identified GP is automatically related to a tissue type. Optionally, the identified GP is related to the tissue type based on the applied image mask. Alternatively or additionally, the identified GP is related to the tissue type based

on the characteristics of the intensity readings. For example, large sizes (denoting large GPs) are potentially only to be found in certain tissues. Optionally, different types of GPs are related to different tissues. For example, myocardial GPs are related to the myocardium and/or epicardial GPs are related to the epicardium.

5 In some embodiments of the invention, at block **380**, one or more parameters are calculated for the identified GPs (also referred to herein as GP parameters). Examples of parameters include:

- average size;
- specific activity—expressed, for example, in counts per voxel and/or
10 GP/average counts in the corresponding image mask volume;
- power spectra—for example, the power below 1 Hz, power between 1–5 Hz, and/or a ratio of high to low frequencies;
- normalized power spectra;
- GP connectivity map—for example, connectivity and interaction between
15 different GPs; and/or
- number of GPs per predefined area—expressed, for example, as GP density number/cm².

For identified EGP, one or more of following parameters is calculated in some embodiments: EGP size, EGP specific activity, EPG power spectra graph, EGP
20 normalized power spectra, and/or a map of EGP connectivity. EGP normalized power spectra are calculated, in some embodiments, as the difference between the EGP power at different frequencies minus the power of the total counts from the myocardial image mask space.

Optionally, calculation of GP parameters is performed per frame, optionally per
25 frame of the dynamic cycle (e.g., cardiac cycle).

In some embodiments of the invention, at block **382**, the calculated and/or other parameters are normalized. Normalization optionally takes place at one or more blocks of the method, for example, during and/or after acquiring the functional and/or anatomical images, upon calculation of functional activity, upon identification of GPs,
30 upon calculating parameters for the GP, upon comparison of data over time, or at other blocks.

Examples of normalization techniques include:

- raw data;
- raw data divided by the raw data value in a known fixed anatomical location acquired at roughly the same time, for example, the activity of the tracer in the patient's mediastinum;
- 5 • normalization to a normal patient data set;
- normalization to a value of the activity at the first or the last image acquisition from a sequence of acquisitions;
- normalization to value acquired in different physiological states such as rest/stress;
- 10 • a combination of some or all of the above; and/or
- other methods.

Alternatively, normalization is performed instead of and/or in addition to the normalization of block **382** before a different block in the process. For example, normalization is optionally applied before GPs are identified in block **378**.
15 Normalization potentially assists identifying the GPs. For example, activity at a local region, such as mIBG activity, is compared to an average value and/or standard deviation across the organ volume, within the image mask space and/or relative to a predefined threshold.

Alternatively or additionally, the calculated data (e.g., blocks **374**, **378**, **380**)
20 and/or measured functional intensity are corrected for sensitivity. Optionally, sensitivity correction is performed within each image mask and/or in related image masks. For example, different areas potentially have relatively higher or lower sensitivity to uptake of the radioagent. Optionally, the anatomical data is correlated to the sensitivity. Optionally, the image masks are generated (block **370**) based on different sensitivity
25 levels; for example: one set of image masks for higher sensitivity nerve structures, and another set of image masks for lower sensitivity nerve structures. Optionally, the different sensitivities are normalized to a common baseline.

Alternatively or additionally, measurements of the functional data are normalized. For example, measurements of uptake of the radioagent are normalized to
30 the level of corresponding chemical in the patient. Optionally, intensity measurements are normalized according to the level of activity of GP being identified. Optionally, measurements denoting activity of the GPs are taken. For example, in the case of mIBG,

measurements are optionally normalized to the level of norepinephrine (NE), adrenaline and/or epinephrine in the patient. Optionally, the level of NE is measured in the blood, urine, or other body fluids. Intensity of mIBG uptake is normalized based on the measured NE.

5 Additionally or alternatively, mIBG measurements are normalized to a decay function, such as decay over time since injection of mIBG. In another example, the level of activity is measured by non-chemical methods. For example, normalization of mIBG is performed based on measurements taken during a cardiac stress test. Measurements comprise, for example, ECG measurements, heart rate, cardiac output, and/or other
10 measurements. Optionally, measurements are correlated with levels of activity of the GPs being identified, for example by a table, mathematical equation, or other method.

 Additionally or alternatively, measurements of functional data are normalized to a level of one or more electrical properties. For example, functional data are normalized to impulse conduction velocity, refractory period, a measured electrical potential (at one
15 or more phases of contractile state), or another property of the electrical activity of the tissue. Optionally, additional weight is given to regions where conduction is particularly poor: slow to transmit and/or slow to recover, for instance. This is a potential advantage, for example, when evaluating a heart region for severity of disease, and/or for comparing regions for their relative severity of disease.

20 In some embodiments of the invention, at block **384**, data is compared over time. Optionally, changes in GP parameters over time are identified. Optionally, dynamic changes of the calculated parameters between different acquisition times are determined. For example, the changes in GP activity over time are calculated, from injection till 6 hours post injection, by repeating the image acquisition several times
25 during this time window. The functional images are optionally acquired at more than one time after the tracer injection.

 In some embodiments of the invention, at block **386**, a functional image is reconstructed based on the mask applied to the functional data and/or image. Alternatively or additionally, an image is reconstructed based on the mask applied to the
30 combined functional and anatomical data and/or images. The reconstructed image potentially contains the identified GPs, for example, as regions of increased intensity.

The reconstructed image is optionally overlaid on the anatomical image, illustrating the physical location of the GPs.

Alternatively or additionally, the characteristics of the GPs within the functional image are reconstructed. The reconstruction is instructed by the image mask.

5 In some embodiments of the invention, at block **388**, the calculated results from, for example, block **378**, **380**, **382** and/or **384**, and/or reconstructed images (block **386**) are provided for presentation or otherwise provided to the operator. They are, for example, presented on a monitor to a physician. Additionally or alternatively, the calculated results and/or reconstructed images are stored in a memory for future use,
10 such as diagnosis. The calculated results potentially assist in diagnosing the patient and/or in guiding treatment.

Optionally, the results are provided for presentation on a certain frame, for example, the end systolic frame. Alternatively, results are provided for presentation on multiple frames, for example, a video of the cardiac cycle.

15 In some embodiments, the reconstructed functional image or combined functional and anatomical image is provided for registration during a treatment procedure. Optionally, the reconstructed functional image is overlaid on and/or registered with anatomical images obtained during the treatment procedure. Overlaid and/or registered images are optionally used by the operator to physically determine
20 locations of the GPs during the treatment.

The method of *Figure 8* has been described with reference to the heart. The method is not limited to the heart, and is used in some embodiments for other organs, including hollow fluid filled organs such as stomach, aorta, or bladder; and/or solid organs such as kidney or liver. GPs and/or nerve endings are identifiable in these other
25 organs in some embodiments. For example, the aorta is segmented based on surrounding structure such as bones, muscles, and/or branching arteries; and image masks generated accordingly. The liver, in an exemplary embodiment, is segmented based on anatomical liver lobe divisions.

ANS Mapping system or unit

30 Reference is now made to *Figure 9*, which is a block diagram of a model ANS modeling system/unit **1006**, in accordance with some exemplary embodiments of the invention.

In some embodiments, ANS modeling system/unit **1006** is provided as a part of a system **900** including functionalities with which ANS modeling system/unit coordinates in series or in parallel. For example, a system **900** includes a functional imaging modality **1008A** (such as a SPECT imager), and/or an anatomical modeling
5 modality **1008B**. Anatomical image modality data comprises data obtained, for example, from a CT (X-ray or gamma-ray, for instance), MRI, 3-D ultrasound, 2-D ultrasound, or by another modality. Optionally, an ANS modeling system/unit is comprised in part of another system configuration, such as a system **1000**, as described in relation to *Figure 10* hereinbelow.

10 In some embodiments of the invention, ANS module **1006** receives functional images and/or imaging data **1012A** (for example, as produced by functional imaging modality **1008A**); and anatomical images and/or imaging data **1012B** (for example, as produced by anatomical imaging modality **1008B**).

The ANS module itself produces model information **1020** comprising
15 information, about, for example, GP locations, interconnections and/or activity levels. In some embodiments, image data within GP locations resolves one or more distinct and/or identifiable GP regions. Production of an ANS model comprises, for example, one or more of the blocks described in relation to *Figure 8*, hereinabove.

In some embodiments of the invention, ANS module **1006** comprises processor
20 controller **906**. Processor/controller carries out computational tasks of ANS model generation, for example, computational tasks described in relation to *Figure 8*, hereinabove. Optionally, ANS module **1006** is provide with a GUI **908**. In some embodiments, ANS module **1006** comprises memory **904**, used, for example to receive and store images, associated data, model information, and/or process/controller
25 instructions. Optionally, GUI **908** is used, for example, in the selection of image sources, images, and/or regions of data for analysis. Optionally or alternatively, GUI **908** is used, for example, to show model results; for example: regions of tissue health or disease, regions of innervation or lack of innervation, regions of nervous system activity/inactivity, and/or any of these regions in relation to one another. In some
30 embodiments, ANS module **1006** comprises a workstation **910**. The workstation itself, in some embodiments, optionally comprises the processor/controller **906** and/or GUI **908**. In some embodiments, functions of workstation **910** are distributed; for example, at

least a part of ANS modeling carried out by processor/controller **906** is calculated remotely, for example, as a provided service.

In some embodiments, a system **900** includes one or more tools for a treatment option such as GP ablation, stimulation, anesthesia, or another neuromodulatory intervention. In some embodiments, system **900** is operable for guidance of a probe for treatment based on real-time display of a probe and ANS map in registration, direct (for example, robotic) guidance of probe position, or another method of ANSmap-guided treatment and/or treatment probe placement.

Exemplary diagnosis and treatment subsystem

Reference is now made to *Figure 10*, which is a block diagram of a model analysis and treatment planning system/unit **1000**, in accordance with some exemplary embodiments of the invention.

In some embodiments, once a model is available, it is used for diagnosis and/or planning a treatment for example as described hereinabove. Groups of elements comprising a system/unit **1000** include, for example, blocks within the boundaries delineating system configurations **1000A**, **1000B**, **1000C**, **1000D**, and/or another system configuration comprising blocks of *Figure 10*.

In some embodiments, unit **1000** carries out functions of various model analyses described herein, for example, in relation to *Figure 9*. For example, it includes analysis/modeling subsystem **1006**, as in configuration **1000C**. In some embodiments, unit **1000** is integral to and/or co-located with imaging and/or treatment systems (for example, it includes imaging subsystem(s) **1008**, as in configuration **1000D**). In some embodiments (for example, including analysis/modeling subsystem **1006**), images and imaging data **1012** are received by the system/unit **1000**. In some embodiments (for example, including imaging subsystem(s) **1008**), images and imaging data **1012** are generated by the system/unit **1000**. In some embodiments, imaging subsystems **1008** include an imaging modality described in relation to *Figure 9*, for example, a functioning imaging modality **1008A**, and/or an anatomical imaging modality **1008B**.

In some embodiments, unit **1000** (for example, configurations **1000A** and/or **1000B**) is remotely located relative to other subsystems, and/or is distributed. Optionally, the functions of, for example, subsystem **1000A** are provided as a service. In exemplary embodiments of the invention, rather than provide a user with a model of the

ANS **1020**, what is provided is a combination model and treatment plan (for example, a combination comprising the information of model information **1020** and treatment plan **1032**) or possibly just a treatment plan **1032**. Some exemplary treatment plans **1032** are described below. In some embodiments, the ANS and/or its activity are described as a pattern (which is not necessarily a model as such), and the pattern becomes the basis for classification with respect to the identification of diagnosis and/or planning of treatment.

In a first stage of operation of some embodiments of the invention, model information **1020** and patient information **1022** provided to a diagnosis subsystem **1002**. Model information **1020** includes, for example, GP locations, interconnection and/or activity level. Patient information **1022** includes, for example, patient demographics, history and/or previous response to therapy. Optionally, diagnosis subsystem **1002** uses a diagnosis database **1024** to assist in providing a diagnosis. Diagnosis database **1024** includes, for example, rules, example diagnoses, and/or machine learning data. Optionally or alternatively, diagnosis subsystem **1002** includes one or more modules which apply processing on the model to extract diagnose. In some exemplary embodiments of the invention, the diagnosis database **1024** is updatable and/or parts thereof are available at different and/or additional cost.

The output of diagnosis system **1002**, in some embodiments, is a personalized diagnosis **1030**. In some exemplary embodiments of the invention, the diagnosis database **1024** includes a plurality of templates, each one optionally associated with one or more possible diagnoses and/or including instruction for missing data to assist in diagnosis. Optionally or alternatively, at least one dynamic template is used. Such a template is potentially useful, for example, if a disease is characterized by a temporal pattern of behavior. Such a template includes, for example, multiple snapshots with a time indicator, and/or defines a function of change over time and/or in response to a trigger.

In some exemplary embodiments of the invention, personalized diagnosis **1030** is provided to a planning subsystem **1004**. In some embodiments, planning subsystem **1004** generates a treatment plan suitable for the patient, based on the diagnosis and/or best practices. Optionally, a treatment database **1026** is used to aid in treatment

planning. The treatment database **1026** includes, for example, exemplary treatments, and/or rules for applying them.

Optionally or alternatively, planning subsystem **1004** uses modules to plan various parts of the treatment and/or to determine if parts of the treatment are reasonable
5 and/or safe. Optionally, model information **1020** and/or patient information **1022** also serve as input for the treatment planning. For example, the information **1020**, **1022** is used to help determine what effect a treatment may have on a patient. In some embodiments, the result is a treatment plan **1032**.

In some exemplary embodiments of the invention, treatment plan **1032** includes
10 one or more of: a plurality of locations to be treated, an expected measurement for the effect of treatment of a location, treatment parameters for one or more of the location treatments and/or alternatives for one or more of the locations. Optionally, the plan **1032** includes a time line indicating the order of treatment and/or delay times between treatment locations.

15 In some exemplary embodiments of the invention, a treatment is defined with a time scale of several minutes, hours or days; for example, defining a wait of between 1 and 1010 minutes or between 1 and 20 hours between treatment locations.

It should be noted that diagnosis and/or modeling is potentially improved, in some embodiments, by taking into account the effect of treatment. In some exemplary
20 embodiments of the invention, a treatment plan **1032** includes a suggestion to recalculate model and/or diagnosis and/or treatment plan, for example, in response to a measurement exceeding a certain threshold or matching a certain pattern, and/or otherwise to fulfill a rule.

ANS-Disease Decoder (ADD)

25 Reference is now made to *Figure 12*, which is a schematic flowchart **1200** showing the operation of an ANS-disease decoder (ADD), according to some exemplary embodiments of the invention.

At block **1202**, in some embodiments, ANS measurements are provided, acquired, for example, according to a method described in relation to *Figures 1–5*
30 and/or *Figure 8*. Optionally, measurements are provided as a pattern of activations. Optionally, measurements are entered into a model description of the ANS from which they were obtained. In some embodiments, ANS measurements correspond, for

example, to model information **1020**. In some embodiments, the ADD receives information from earlier in the processing chain of *Figure 10*, for example, original images and/or imaging data.

At block **1204**, in some embodiments, organ and/or organ system measurements
5 related to organ function are provided; for example: a measure of a metabolite level, hormonal level, physiological parameter such as heart rate, muscle state (for example, state of distension of a bladder and/or stomach), or another parameter, obtained, for example, as described in relation to *Figures 1–5* hereinabove. In some embodiments, measurements comprise, for example, patient information **1022**.

10 In some embodiments, data provided at blocks **1202** and/or **1204** was obtained with known relative timing (between the two blocks) during manipulation of organ and/or ANS function and/or state. Manipulation potentially allows determination of a relationship between variables, such as showing their relative tendencies to change, either due to causal relationships between them, or to common dependencies on
15 separate cause. Manipulation is, for example, by administration of a drug, administration and/or withholding of food or liquid, control of activity level, control of voluntary aspects related to disease symptoms, or another appropriate manipulation, for example as described in relation to *Figures 1–5* hereinabove. Additionally or alternatively, manipulation is of the ANS, for example as described hereinabove.

20 At block **1210**, in some embodiments, an ANS-disease decoder (ADD) operates based on the received measurement inputs to generate output related to disease diagnosis and/or treatment options. In some embodiments of the invention, ADD corresponds to one or more functions of system configuration **1000A**, for example, the functionalities of diagnosis subsystem **1002**, and/or a planning subsystem **1004**.

25 At blocks **1215** and/or **1220**, in some embodiments, the output is provided. In some embodiments, the output comprises a diagnosis of one or more potentially pathological modes of interaction between the organ and/or organ system and the ANS. Optionally or alternatively, the output comprises one or more treatment options. In some
30 embodiments, treatment options are presented in the form of a map, for example, a map of ANS regions. Options are indicated, for example, as a suggested location for one or more interventions to alter ANS activity levels.

Details of the operation of exemplary embodiments of an ADD **1210** are now described in further detail.

Reference is now made to *Figure 13*, which is a schematic flowchart **1300** of an initial phase of analysis performed by an ADD unit **1210**, according to some exemplary
5 embodiments of the invention. The flowchart **1300** represents a portion of processing carried out by ADD **1210**, corresponding, in some embodiments, to an initial phase of detecting in the received data salient features on the basis of which diagnosis and/or treatment options are to be determined.

At block **1302**, in some embodiments, the signals (measurements) **1202**, **1204**
10 received by the ADD **1210** are preconditioned. Preconditioning comprises, for example, operations on data corresponding to those described in relation to *Figure 8* (creation of an ANS map). Preconditioning optionally comprises, for example, normalization; relating measurements to particular times, places, and/or conditions of acquisition; and/or other processing suitable to convert it to a form usable with the processing of
15 block **1304**.

At block **1304**, in some embodiments, ANS measurements and organ (and/or system) measurements are brought into a mapped relationship. At block **1306**, the map is analyzed. Particular features detected by the ADD **120** are shown in blocks **1308** (monotony), **1310** (peaks and troughs), and **1312** (repellers and attractors).

Reference is now made to *Figure 14*, which is a schematic graph **1400** of a
20 mapping between organ/system function and/or state, according to some exemplary embodiments of the invention.

Trace **1401** represents an exemplary relationship (taken through some range of overall conditions) between a quantifiable function and/or state relevant to disease
25 (“Organ/System Function/State”), and ANS state (“ANS State (Activity)”). In a simplified case, ANS state can be represented by the level of activity of a single ganglion. However, it should be understood that ANS state, in some embodiments, comprises a multidimensional function of 2, 3, 4 or more different ANS measurements. In a multidimensional condition, certain additional possibilities can occur, such as
30 conversion of point-like attractor/repeller limits into limits having extension (line-like, plane-like or other), and potentially allowing a greater combination of states.

Consideration of such more general conditions is also found, for example, in the **Overview** section, hereinabove.

In a simplified case, the organ/system function and/or state is represented, for example, by the level of a single measurement. Such a single measurement optionally
5 comprises, for example, pulse rate, blood pressure, and/or another indication of activity or function such as imaged uptake of a radiolabeled metabolic marker; blood glucose level, and/or a level of another blood-borne marker of function and/or activity such as a hormone or factor; or another parameter of bodily function and/or activity. It should be understood, however, that in some embodiments the organ/system function and/or state
10 measure comprises 2, 3, 4 or more measured variables.

In a simplified case, the graph **1400** represents a hysteresis-free relationship between the organ/system function/state and the ANS state. However, it is to be understood that the relationship between the two is subject to lags, and/or to differences in shape depending on whether movement along the line is driven by forcing of the
15 organ/system function/state (for example, administration of a stress to change the heart rate), forcing of the ANS activity state (for example, by direct or indirect stimulation and/or pharmacological blocking), or by a more generalized stimulus which shifts the system state, by a mechanism of action which is indeterminately on the ANS or the innervated organ/system of interest.

Nevertheless, given control and/or monitoring of even just two variables of the
20 system, an overall shape of the graph can potentially be determined with sufficient resolution to reveal its salient features. In some embodiments, knowledge of these features guides analysis of the disease, leading to diagnosis. In some embodiments, knowledge of these features allows determination of manipulations of the ANS which
25 treat disorders reflected in the state map **1400**.

In particular, the graph of an organ/system and its control potentially comprises local and/or global peaks (**1405A**, **1405B**) and troughs (**1410A**, **1410B**, **1420**) in the homeostatic function which describes their relationship. The range of the graph at or
30 near the bottoms of the troughs **1410A**, **1410B**, **1420** are “attractors”, in that, in the absence of driving external to the variables being considered, the homeostatic system tends to move toward the nearest such trough. It should be understood that this movement toward a trough, according to the specifics of the case, can comprise either

increase or decrease in a metric. For example, ANS activity may rise or fall as a trough bottom is approached; similarly, organ/system state/function measurement can rise or fall. It can be readily understood that where the homeostasis graph is a simple “U” shape, there is only one minimum, the global one, and the system tends to approach this
5 from any point on the homeostasis graph.

However, in some instances, derangement in a system's homeostasis can be understood as the appearance and/or strengthened effect of “repellers” (ranges of the control graph at and/or near the peaks **1405A**, **1405B**), which block movement to a preferred state and/or strengthen the “attractiveness” of a non-preferred state. In another
10 sense, a “repeller” is a region of a control graph which a system tends to move away from in the absence of external driving. In such a system, there can be a plurality of minima, some of which potentially reside in a combination of activities which is pathological. For example, increasing insulin insensitivity by the liver can potentially make it more difficult to cross a repeller threshold, such that the ANS must work
15 especially hard to “bump” the system into a preferred state. Considering the potential effects of physiological variables representing third and higher dimensions, a system can potentially even “go on a walk” (also described hereinabove as an “orbit”), spilling into a range where the 2-D cross section represented by the graph of state map **1400** changes completely due to movement in this physiological “third dimension”. Examples
20 described herein provide exemplary instances of diseases where homeostasis is changed from a condition of normal functioning into a functional state which describable as disturbed (not operating normally), vulnerable to disturbance (possibly operating normally, but easily disturbed), deranged (not operating within normal parameters), dysfunctional (disturbed, vulnerable to disturbance, and/or deranged), and/or
25 pathological (having dysfunction which presents as disease). A disturbance in attractors and/or repellers comprises, for example, an excursion of the control function through a range of about 10% of the observed functional range of the parameter. Also for example, the excursion is about 20%, 30%, 40%, or another greater, smaller, and/or intermediate relative excursion. In some embodiments, the excursion comprises the addition of a
30 repeller, the addition of an attractor, the reduction of a repeller, and/or the reduction of an attractor.

Practically, however, there is potentially at any given time a relatively restricted range of accessible states. Furthermore, it is optionally not necessary to sample every point (or even a large number of them) along a homeostasis graph to reveal the existence of peaks and troughs relative to diagnosis and/or treatment. For example
5 observation of an inverting relationship in the change of ANS activity and organ/system state between regions of monotonic increase or decrease (monotony) **1415B** and **1415C** is potentially sufficient to identify the existence of an intermediate peak. The inversion is potentially identified as specifically a peak, by observing the tendency of the system to naturally move away from it in the absence of a counteracting driving force.
10 Similarly, a minimum **1420** is detectable even away from the minimum itself, for example, by observation of behavior at regions of monotony **1415C** and **1415D**. Additionally or alternatively, it can be inferred that at least one peak and valley exist between regions of monotony **1415A** and **1415B**, based on the relaxation behavior and/or relative driven responses measured there.

15 Reference is now made to *Figure 15*, which schematically illustrates a diagnostic measurement configuration **1500**, allowing measurements of a physiological parameter's changes in response to manipulation, together with measurements of ANS activity, for use in diagnosis and/or treatment determination, according to some exemplary embodiments of the invention.

20 The exemplary situation shown shows how induction (forcing) of state changes by a manipulation (which in this case happens to be controlled-rate injection of a drug), can be combined with simultaneous measurement of ANS activity and some chosen physiological parameter to yield data for input into the ADD **1210**.

Motorized syringe **1512** is connected via IV line to subject **1505**, and is
25 configured to deliver a controlled-rate dose of a pressor agent such as prostacyclin during imaging of ANS activity, for example, by a SPECT instrument **1514**. During the period of imaging, blood pressure is measured by a blood pressure monitor **1510**, with the target range of pressures being, for example, between 90 mmHg and 200 mmHg.

Blood pressure information and information representing activity levels of ANS
30 ganglion loci **1502A**, **1502B** (optionally, together with anatomically information specifying the relative positions of other internal organs **1508** are brought together in the ADD. In a patient with a healthy innervation pattern, it is to be expected that as

blood pressure rises, sympathetic activity levels in the innervation to the arteries (which is itself vasoconstrictive) should monotonically decrease. If, at some point along the graph of increasing blood pressure, one or more sympathetic ganglia are seen to reverse their direction of change (so that they increase activity with increasing blood pressure), it indicates a potential finding of a “repeller” state. Even with the drug forcing turned off, such a ganglion would be working to force the blood pressure higher, rather than lower as long as it was working in such a mode. A repeller condition could indicate, for example, that an organ/system has been brought to a state during the period of elevated blood pressure which activates the sympathetic system more strongly than elevated blood pressure depresses it. Additionally or alternatively, sympathetic sensitivity to elevated blood pressure is reduced (for example, due to loss of sensory inputs), so that it is less sensitive to what would normally be an overriding input. In either case, a potential treatment would be to ablate or otherwise deliberately impair sympathetic function.

Potentially, this trades a generalized degradation of regulatory function for the eradication of a specifically dangerous mode of operation. In some instances, it is potentially found that increased sympathetic innervation can be selectively attributed to a subset of imaged ANS ganglia: for example, ganglion **1502B**, but not ganglion **1502A**. In such cases, it is a potential advantage to know which ganglia are the strongest sources of “repeller” innervation, so that they can be target while leaving other ANS structures intact.

Reference is now made to *Figure 16*, which is a partial schematic flowchart **1600** of operations performed by an ADD **1210** to convert received function data **1601**, **1601A**, **1601B** into determination of an intervention, according to some exemplary embodiments of the invention.

The flowchart portion begins, in some embodiments of the invention, with the receipt of data **1601**, which comprises, for example, ANS measurements **1202** and organ/system measurements **1204**. At block **1602**, in some embodiments, identification of attractors/repellers is performed, for example, according to operations described in relation to *Figure 13*.

At block **1604**, in some embodiments, interventions are identified. In some embodiments of the invention, identification of interventions comprises pattern

recognition, where a recognized pattern is mapped to one or more previously determined treatment options. In a relatively simple example of such mapping, a ganglion showing a reversing pattern of activity response through a range of organ function/state level where a monotonic response is expected is simply recognized as “faulty”, and targeted for ablation or another form of inactivation.

In some embodiments of the invention, a modeling approach is taken, at least in part. For example, weights are assigned to the importance of noted activity centers as targets for intervention. In some embodiments, weighting depends, for example, on observed relative intensities, typical strength of effect in proportion to activity, and/or another parameter. Parameters are determined based on empirical experience and/or modeled considerations based on estimates. In some embodiments, machine learning comprises prospectively exploring a range of available options, leading to a suggested intervention which “optimally” (at least, insofar as the model is accurate) balances constraints such as surgical practicality, minimized side-effects, certainty of effect, and/or other constraints which are set to constrain the output to have a targeted effect.

In some embodiments of the invention, more than one sequence of ANS/organ state maps are available to the operations of blocks **1602** and/or **1604**. The sequences optionally comprise repeated runs of the same mapping conditions. Optionally, sequence map ANS activity in response to two or more different types of manipulations. Potentially, the multidimensional approach allows a greater range of possible manipulations to be identified. It is possible, some embodiments, that data will be suggestive of homeostatic features such as undesired attractors or repellers outside of the explored range. In some embodiments, additional tests are performed based on to expand the range of data available on which to make a treatment decision. In some embodiments of the invention, the results of past imaging and/or interventions is available to the decision-making algorithm, as a basis on which to refine modeled manipulations and/or select relevant patterns of activity and their appropriate intervention.

Reference is now made to *Figure 17*, which is a schematic flowchart **1700** describing the ADD-moderated determination of application of treatment to ANS GP targeted for treatment, according to some exemplary embodiments of the invention.

At block **1702**, in some embodiments of the invention, attractor/repeller features of the observed pattern of one or more homeostasis maps are selected for repair. Determination comprises, for example, tests and analyses described in relation to *Figures 12–16* hereinabove.

5 At block **1704**, in some embodiments, a strategy is selected for intervention. For example, treatment targeting is determined for a particular ANS structure, such as a GP or nerve fiber. Selection comprises, for example, determination of which GP most contributes to the pattern that creates a targeted attractor or repeller. Optionally, the strategy is determined by the ADD, according to a list, match, model or other method of
10 treatment specification. Optionally, the strategy is selected by a physician, based on ADD output which highlights one or more ANS targets for intervention. Three strategy types are described, corresponding to branches A, B, and C from block **1704**.

At block **1706**, in some embodiments of the invention, strategy A is implemented. In some embodiments, a temporary block to a targeted GP is delivered.
15 For example, a GP is cooled, drugged, or otherwise inactivated. At block **1712**, in some embodiments, the success of the block is determined. Optionally, a test is performed; for example, a paired ANS-imaging/organ-function-measuring session. If the results of the test show that a desired modification of the homeostasis map has been achieved, then, optionally, permanent and/or long-term ablation is performed at block **1714** by ablating
20 the targeted GP. Optionally, in case blocking the targeted GP has not had the desired effect, the flowchart return to block **1702**, and another attempt, optionally one refined by the test data, is made to select an attractor repeller and/or choose a treatment strategy.

At block **1708**, in some embodiments of the invention, strategy B is implemented. Strategy B comprises supplying addition afferent input. Afferent input is
25 increase, for example, by supplying a drug known to have potentiating effects on the type of afferent input which is targeted for enhancement. In some embodiments, the drug is supplied in a targeted fashion, for example, by means of an eluting implant. In some embodiments, afferent input is supplied by means of an electrical and/or electromagnetic stimulation device. Optionally, the device is implanted. Optionally, the
30 device operates transcutaneously. In some embodiments of the invention, afferent fiber proliferation is encouraged, for example, by denervating a complementary pathway,

supplying trophic and/or structure support for fiber growth, suppression of factors inhibiting innervation, or another method of shaping innervation.

At block **1710**, in some embodiments of the invention, strategy C is implemented. In some embodiments, an afferent pathway is intervened with. Some forms of pathway-directed positive intervention are described in relation to strategy B. Negative intervention comprises full or partial ablation of an innervation pathway. Optionally, an overactive pathway is directly ablated in order to reduce overactivity. In some embodiments, a negative intervention comprises full or partial ablation of a pathway which inhibits underactive innervation. Other examples of interventions affecting ANS activity levels and/or the effectiveness of ANS activity are described hereinabove.

As used herein, the term “about” refers to within $\pm 10\%$.

The terms “comprises”, “comprising”, “includes”, “including”, “having” and their conjugates mean: “including but not limited to”.

The term “consisting of” means: “including and limited to”.

The term “consisting essentially of” means that the composition, method or structure may include additional ingredients, steps and/or parts, but only if the additional ingredients, steps and/or parts do not materially alter the basic and novel characteristics of the claimed composition, method or structure.

As used herein, the singular form “a”, “an” and “the” include plural references unless the context clearly dictates otherwise. For example, the term “a compound” or “at least one compound” may include a plurality of compounds, including mixtures thereof.

The words “example” and “exemplary” are used herein to mean “serving as an example, instance or illustration”. Any embodiment described as an “example or exemplary” is not necessarily to be construed as preferred or advantageous over other embodiments and/or to exclude the incorporation of features from other embodiments.

The word “optionally” is used herein to mean “is provided in some embodiments and not provided in other embodiments”. Any particular embodiment of the invention may include a plurality of “optional” features except insofar as such features conflict.

As used herein the term “method” refers to manners, means, techniques and procedures for accomplishing a given task including, but not limited to, those manners,

means, techniques and procedures either known to, or readily developed from known manners, means, techniques and procedures by practitioners of the chemical, pharmacological, biological, biochemical and medical arts.

Throughout this application, various embodiments of this invention may be presented in a range format. It should be understood that the description in range format is merely for convenience and brevity and should not be construed as an inflexible limitation on the scope of the invention. Accordingly, the description of a range should be considered to have specifically disclosed all the possible subranges as well as individual numerical values within that range. For example, description of a range such as from 1 to 6 should be considered to have specifically disclosed subranges such as from 1 to 3, from 1 to 4, from 1 to 5, from 2 to 4, from 2 to 6, from 3 to 6, *etc.*, as well as individual numbers within that range, for example, 1, 2, 3, 4, 5, and 6. This applies regardless of the breadth of the range.

Whenever a numerical range is indicated herein, it is meant to include any cited numeral (fractional or integral) within the indicated range. The phrases “ranging/ranges between” a first indicate number and a second indicate number and “ranging/ranges from” a first indicate number “to” a second indicate number are used herein interchangeably and are meant to include the first and second indicated numbers and all the fractional and integral numerals therebetween.

Although the invention has been described in conjunction with specific embodiments thereof, it is evident that many alternatives, modifications and variations will be apparent to those skilled in the art. Accordingly, it is intended to embrace all such alternatives, modifications and variations that fall within the spirit and broad scope of the appended claims.

All publications, patents and patent applications mentioned in this specification are herein incorporated in their entirety by reference into the specification, to the same extent as if each individual publication, patent or patent application was specifically and individually indicated to be incorporated herein by reference. In addition, citation or identification of any reference in this application shall not be construed as an admission that such reference is available as prior art to the present invention. To the extent that section headings are used, they should not be construed as necessarily limiting.

As used herein, the term “treating” includes abrogating, substantially inhibiting, slowing or reversing the progression of a condition, substantially ameliorating clinical or aesthetical symptoms of a condition or substantially preventing the appearance of clinical or aesthetical symptoms of a condition.

5 It is appreciated that certain features of the invention, which are, for clarity, described in the context of separate embodiments, may also be provided in combination in a single embodiment. Conversely, various features of the invention, which are, for brevity, described in the context of a single embodiment, may also be provided separately or in any suitable subcombination or as suitable in any other described
10 embodiment of the invention. Certain features described in the context of various embodiments are not to be considered essential features of those embodiments, unless the embodiment is inoperative without those elements.

WHAT IS CLAIMED IS:

1. A method of treating a medical condition comprising:
determining a pattern of autonomic innervation activity associated with a physiological parameter affecting said medical condition;
matching said determined pattern to a modeled pattern;
selecting an adjustment of said modeled pattern; and
guiding a therapeutic agent to adjust said determined pattern in correspondence with said adjustment of said modeled pattern, thereby treating said medical condition.
2. The method of claim 1, wherein said adjustment of said determined pattern adjusts autonomic control of said physiological parameter from a first mode of modulation to a second mode of modulation.
3. The method of claim 2, wherein a difference between said first and second modes comprises a different homeostatic set point of said physiological parameter.
4. The method of claim 2, wherein a difference between said first and second modes comprises a different range of available values for said physiological parameter.
5. The method of claim 2, wherein said adjustment of said modeled pattern is associated with a mode of autonomic modulation of said physiological parameter.
6. The method of claim 5, wherein said second mode of modulation corresponds to said associated mode.
7. The method of claim 1, wherein said determined pattern comprises activity measured for a plurality of ANS locations.
8. The method of claim 1, wherein said determined pattern comprises activity measured in at least one ANS location for a plurality of physiological states.
9. The method of claim 1, wherein said guiding comprises administering said therapeutic agent to an ANS location within said determined pattern, said location being chosen for its correspondence to said selected adjustment.
10. The method of claim 1, wherein said guiding comprises administering said therapeutic agent at a time selected for its correspondence to said selected adjustment.

11. The method of claim 1, wherein said guiding comprises administering said therapeutic agent at a dosage chosen for its correspondence to said selected adjustment.
12. The method of claim 2, wherein said second mode of modulation comprises modulation of said physiological parameter away from a physiological norm, relative to said first mode of modulation.
13. The method of claim 2, wherein adjusting said determined pattern adjusts modulation of said physiological parameter to reduce a vulnerability to control feedback leading to a progression of said medical condition.
14. The method of claim 2, wherein adjusting said determined pattern adjusts the sensitivity of a first non-neural system organ to signaling from a second non-neural system organ.
15. The method of claim 2, wherein adjusting said determined pattern affects resizing of the cellular bulk of an organ.
16. The method of claim 2, wherein adjusting said determined pattern comprises reducing ANS activity.
17. The method of claim 2, wherein adjusting said determined pattern comprises increasing ANS activity.
18. The method of claim 1, wherein said matching comprises matching ANS neural function activity levels within anatomically defined boundaries.
19. The method of claim 1, wherein said adjusting comprises balancing ANS neural function activity levels among a plurality of organ or nervous system regions.
20. The method of claim 19, wherein at least two of said plurality of organ or nervous system regions are part of a single organ.
21. The method of any one of claims 19-20, wherein at least two of said plurality of organ or nervous system regions are part of separate organs.
22. The method of claim 1, wherein said determining itself comprises:
 - stimulating to elicit activity in ANS locations; and
 - defining positions involved in said pattern of autonomic innervation activity, based on the positions of said ANS locations.
23. The method of claim 22, wherein said stimulating comprises administering an electrical or electromagnetic pulse.

24. The method of claim 22, wherein said stimulating comprises manipulating a physiological state.
25. The method of claim 1, wherein said matching comprises applying an analysis template configured to transform said pattern according to characteristics relevant to the disease.
26. The method of claim 25, wherein the configuration of said analysis template defines a normalization.
27. The method of claim 25, wherein the configuration of said analysis template defines a mask.
28. A method comprising:
measuring autonomic innervation activity associated with a medical condition; and
applying the results of said measurement to said medical condition.
29. The method of claim 28, wherein said measuring comprises determining the distribution of a tracer.
30. The method of claim 29, wherein said tracer is radioactive, and said determining comprises nuclear imaging.
31. The method of claim 28, wherein said medical condition is selected from among the group comprising: diabetes, benign prostate hyperplasia, erectile dysfunction, rheumatoid arthritis, irritable bowel syndrome, syncope, hypothyroidism, idiopathic heart failure, asthma, deposition disease, IBS, weight gain, hyperhidrosis hypertrophic cardiomyopathy obesity, chronic obstructive pulmonary disease, thyrotoxicosis, hypertension, torticollis, idiopathic dilated cardiomyopathy, right ventricular outflow tachycardia, Brugada syndrome, tetralogy of Fallot, deposition disease of the lungs, sleep apnea asthma metabolic liver disease compromised salivation control, and compromised lacrimation control.
32. The method of claim 28, wherein said applying comprises at least one of the group consisting of:
analyzing said measurement for a pattern of activity relating to said medical condition,
associating a pattern of activity to a treatment for said medical condition,

mapping said pattern of activity to one or more organs or nervous system locations affecting said medical condition,

interpreting said measurement as indicating a particular aspect of said medical condition,

reading said measurement as a description of said medical condition, and examining said measurement for a finding about said medical condition.

33. The method of claim 28, wherein said autonomic innervation activity is measured from a plurality of ANS locations.

34. The method of claim 33, wherein said plurality of ANS locations comprise different regions of the same organ.

35. The method of claim 33, wherein said plurality of ANS locations comprises regions of different organs.

36. The method of claim 33, wherein at least one of said plurality of ANS locations comprises a ganglion providing autonomic innervation to another of said plurality of ANS locations.

37. The method of claim 33, wherein at least one of said ANS locations comprises sympathetic innervation, and at least one of said ANS locations comprises parasympathetic innervation.

38. A system comprising:

a pattern extraction unit, configured to receive measurements of ANS activity, and determine therefrom a pattern reflecting ANS activity relevant to an organ system affected by a medical condition;

a pattern manipulation unit, configured to apply said pattern to highlight a feature of said medical condition.

39. The system of claim 38, wherein said medical condition is selected from among the group comprising: diabetes, benign prostate hyperplasia, erectile dysfunction, rheumatoid arthritis, irritable bowel syndrome, hyperhidrosis hypertrophic cardiomyopathy obesity, chronic obstructive pulmonary disease, thyrotoxicosis, hypertension, syncope, hypothyroidism, idiopathic heart failure, asthma, deposition disease, IBS, weight gain, torticollis, idiopathic dilated cardiomyopathy, right ventricular outflow tachycardia, Brugada syndrome, tetralogy of Fallot, deposition

disease of the lungs, sleep apnea asthma metabolic liver disease compromised salivation control, and compromised lacrimation control.

40. The system of claim 38, wherein said applying comprises at least one of the group consisting of:

analyzing said measurement for a pattern of activity relating to said medical condition, said feature being said pattern of activity;

associating a pattern of activity to a treatment for said medical condition, said feature being said association;

mapping said pattern of activity to one or more organs or nervous system parts affecting said medical condition, said feature being the map of activity to anatomy generated thereby;

interpreting said measurement as indicating a particular aspect of said medical condition, said feature being said particular aspect;

reading said measurement as a description of said medical condition, said feature being said description; and

examining said measurement for a finding about said medical condition, said feature being said finding.

41. A method of characterizing dysfunctional homeostasis, comprising:

receiving autonomic nervous system activity data, and measurements of at least one other physiological parameter related to a homeostatic system;

analyzing a variation relationship between the activity data and the measurements; and

producing, based on the analyzing, a characterizing description of autonomic nervous system activity, associated with an aspect of dysfunction of the homeostatic system.

42. The method of claim 41, wherein said characterizing description comprises described locations of autonomic nervous system loci involved in the dysfunction.

43. The method of claim 41, comprising using said characterizing description to diagnose the role of autonomic nervous system members and/or organs on generation or sustainment of disease.

44. The method of claim 41, comprising using said characterizing description to select a tissue target for intervention, for treating a disease related to the homeostatic dysfunction.

45. The method of claim 44, comprising guiding an agent to modulate activity of said selected tissue target related to said homeostatic system.

46. The method of claim 41, wherein said characterizing description identifies an attractor range in the analyzed variation relationship between the activity data and the measurements.

47. The method of claim 41, wherein said characterizing description identifies a repeller range in the analyzed variation relationship between the activity data and the measurements.

48. The method of claim 41, comprising classification of the characterizing description to a pattern associated with a treatment of a disease involving the dysfunctional homeostasis.

49. The method of claim 41, comprising classification of the characterizing description to a pattern associated with a particular disease state.

50. The method of claim 41, wherein the autonomic nervous system activity data comprise data taken over a range comprising at least two different activity levels.

51. The method of claim 41, wherein the measurements of the at least one other physiological parameter are taken over a range comprising at least two different levels of the physiological parameter.

52. The method of claim 51, wherein the at least two different levels of the physiological parameter comprise a level associated with a healthy state, and a level associated with a pathological state.

53. An autonomic nervous system disease decoding (ADD) system for characterizing a pathological condition, comprising a mapping module, configured to:
receive and autonomic nervous system activity data and physiological parameter measurements, and
map a variation relationship between the activity data and the measurements to produce a control graph.

54. The ADD system of claim 53, comprising a feature detection module, configured to:

classify regions of the control graph, and
produce a characterization of autonomic nervous system activity associated with a dysfunction of the homeostatic system expressed terms of the classified regions.

55. The ADD system of claim 53, wherein the characterization comprises described locations of autonomic nervous system loci.

56. The ADD system of claim 53, comprising a diagnosis module, configured to use the characterization to diagnose the role of autonomic nervous system members and/or organs on generation or sustainment of disease.

57. The ADD system of claim 54, comprising a treatment planning module, configured to uses the characterization to select a tissue target for intervention, for treating a disease related to the homeostatic system dysfunction.

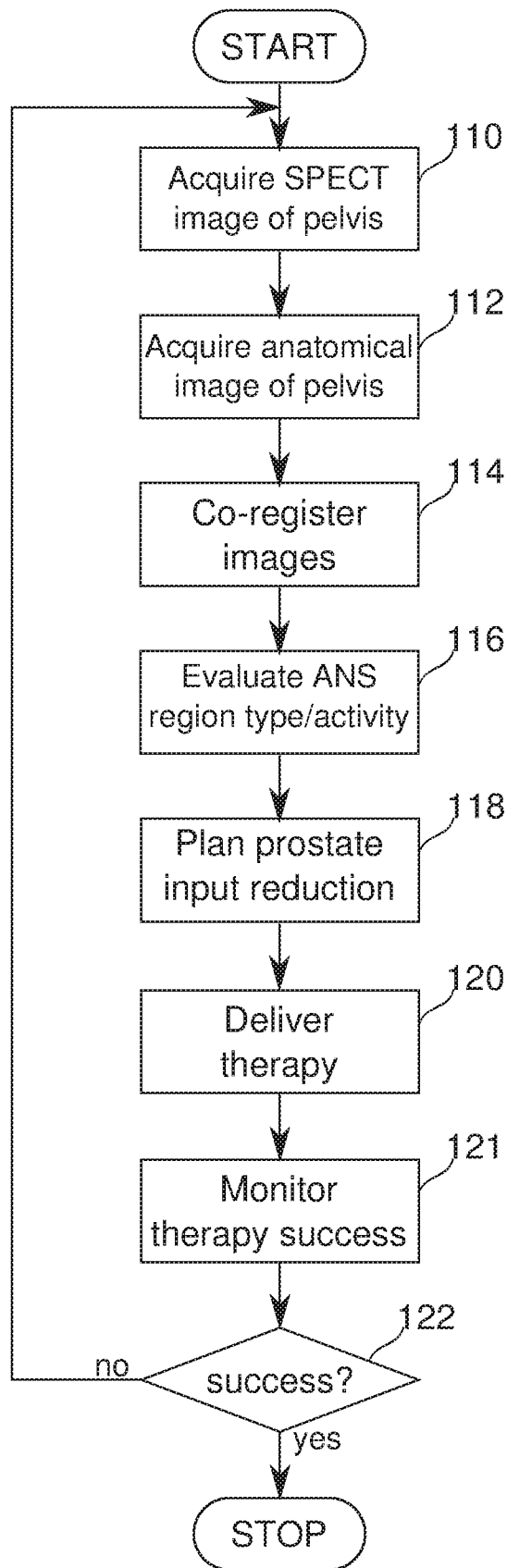

FIG. 1

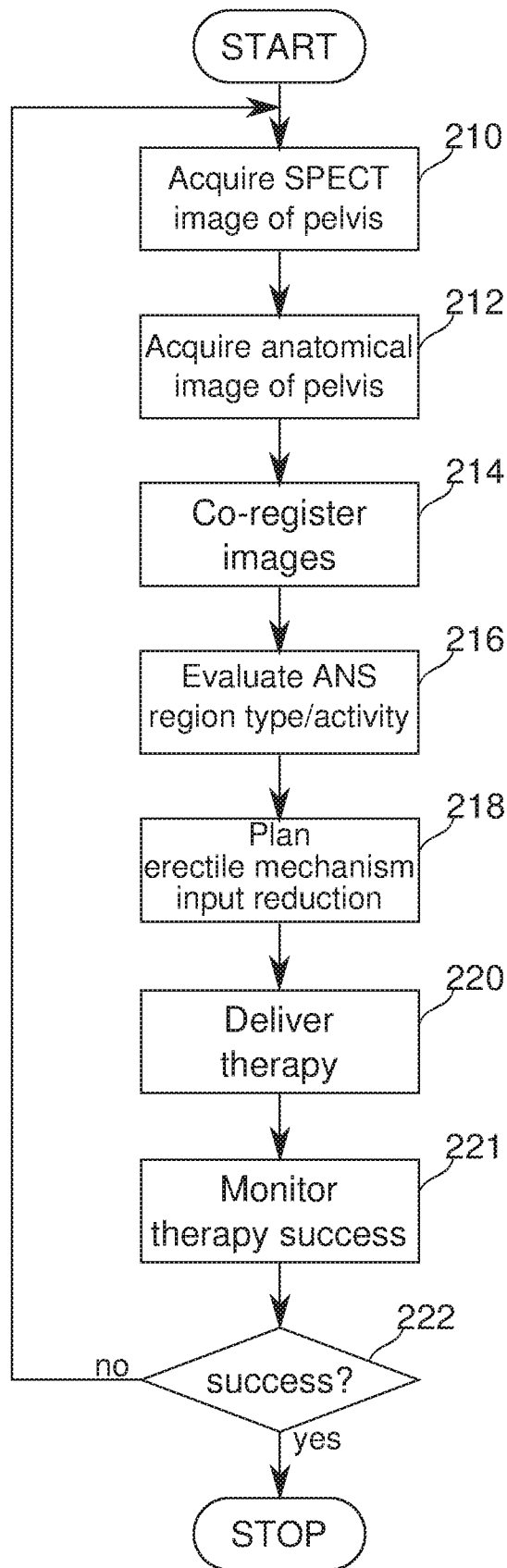

FIG. 2

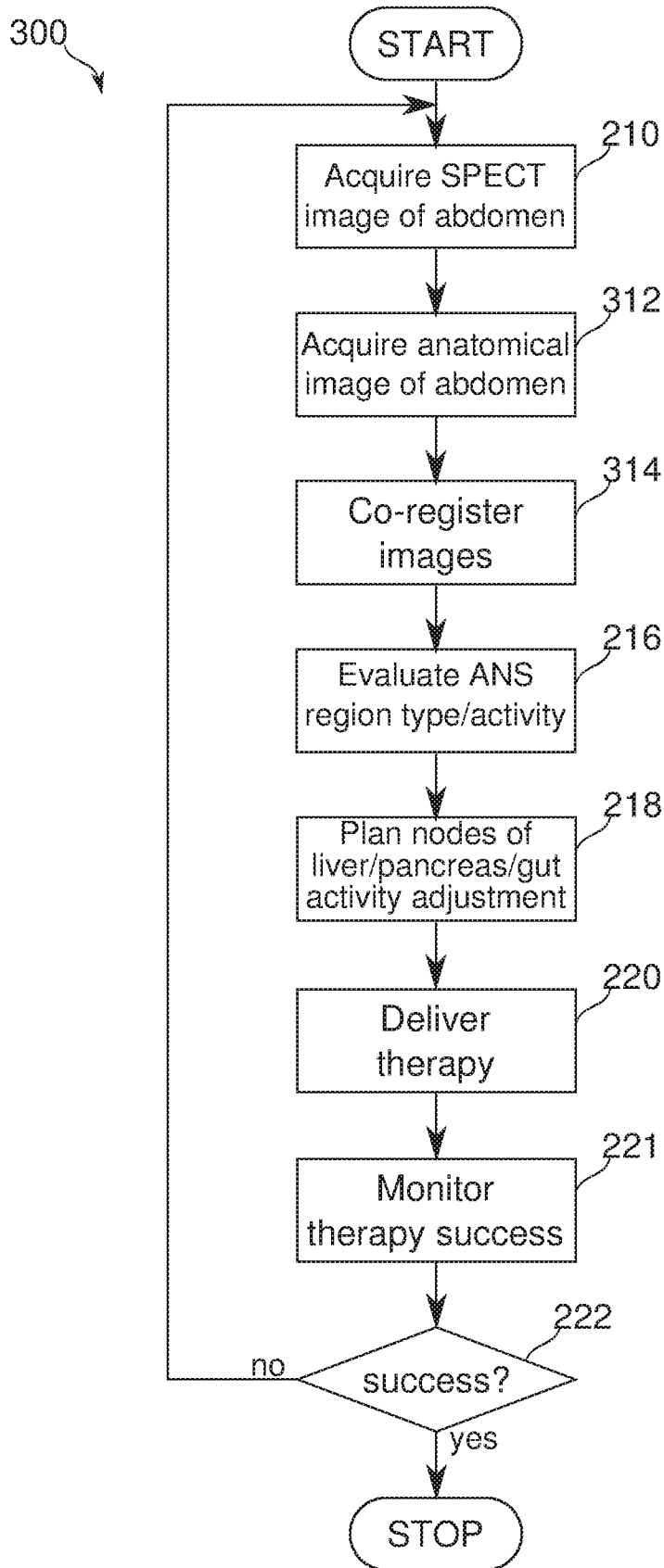

FIG. 3

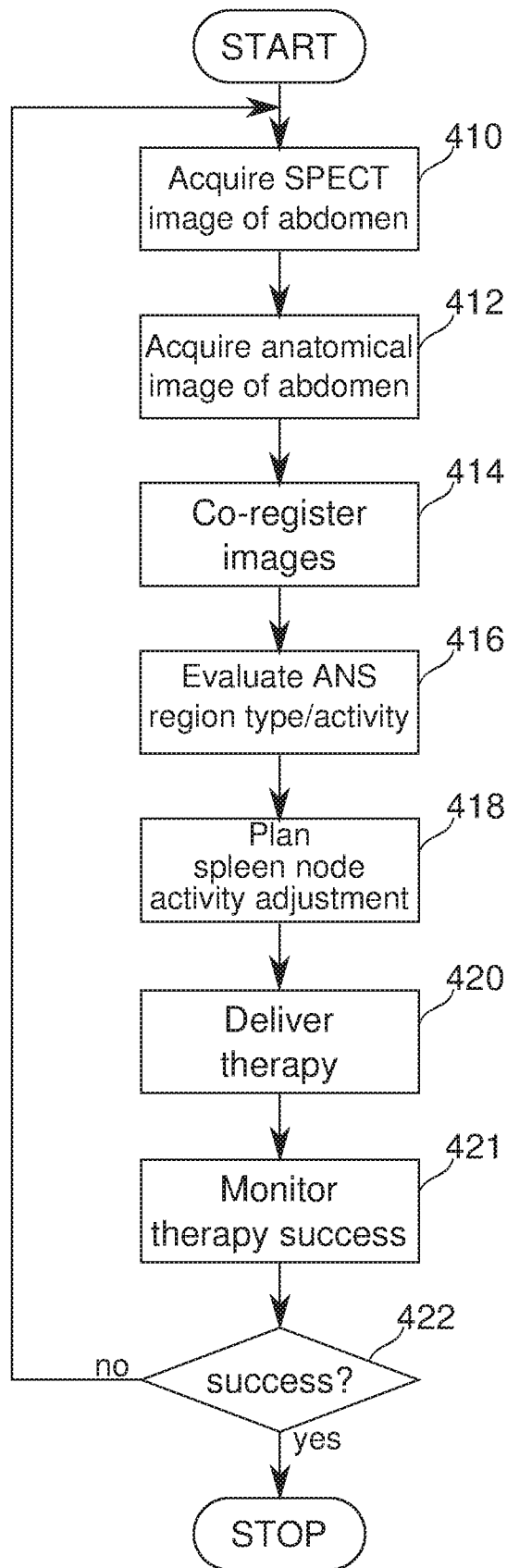

FIG. 4

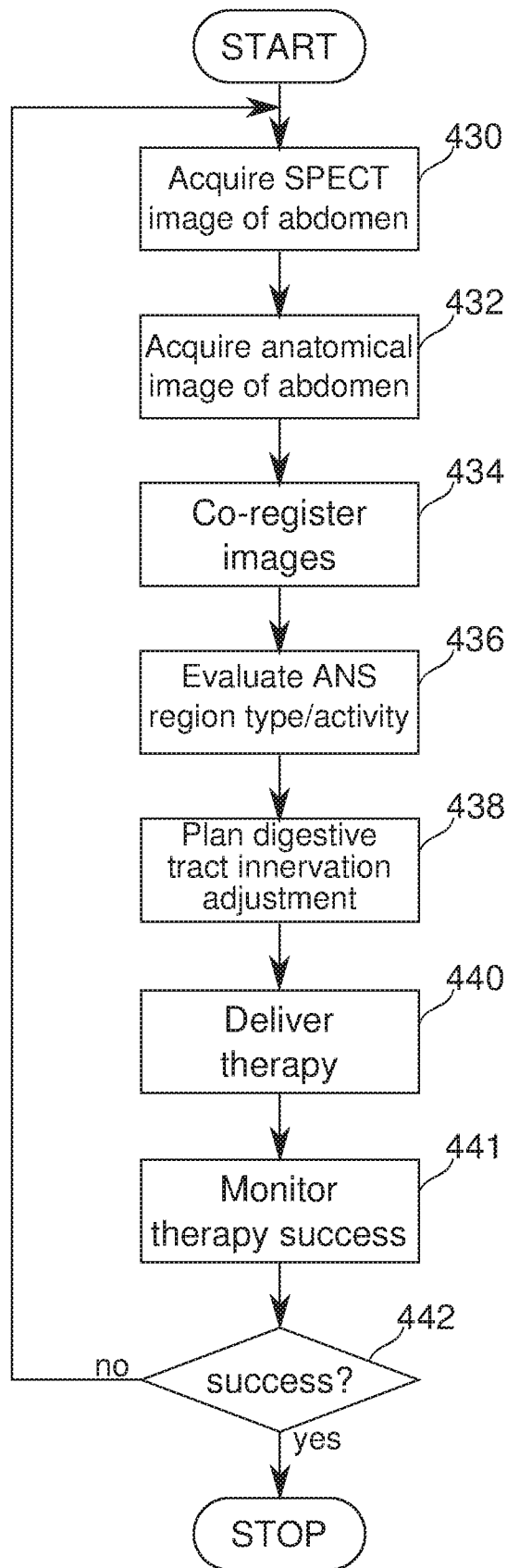

FIG. 5

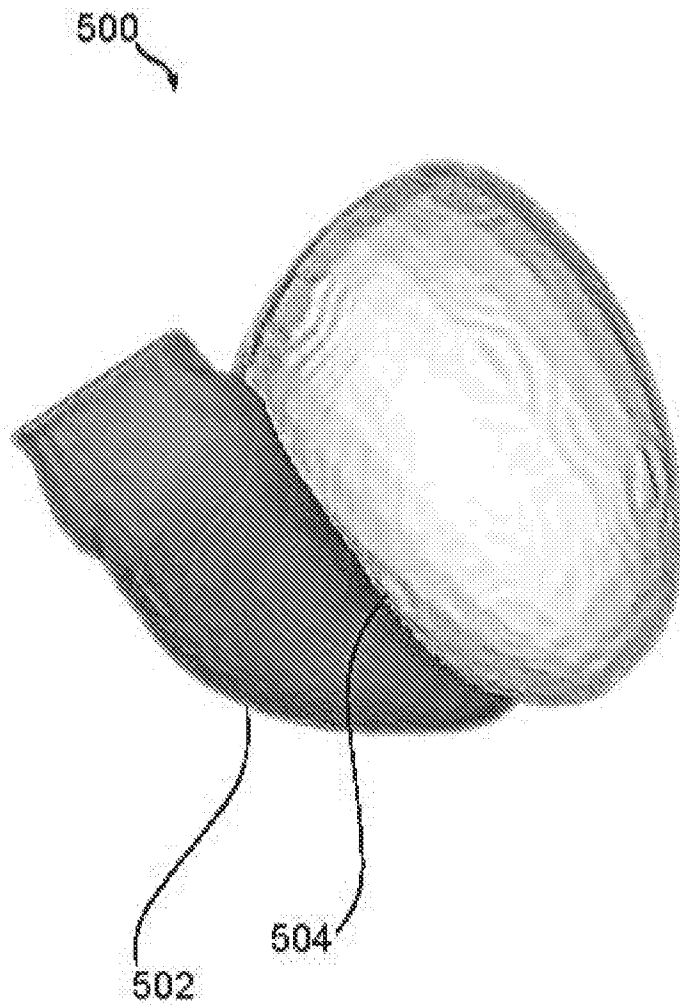

FIG. 6

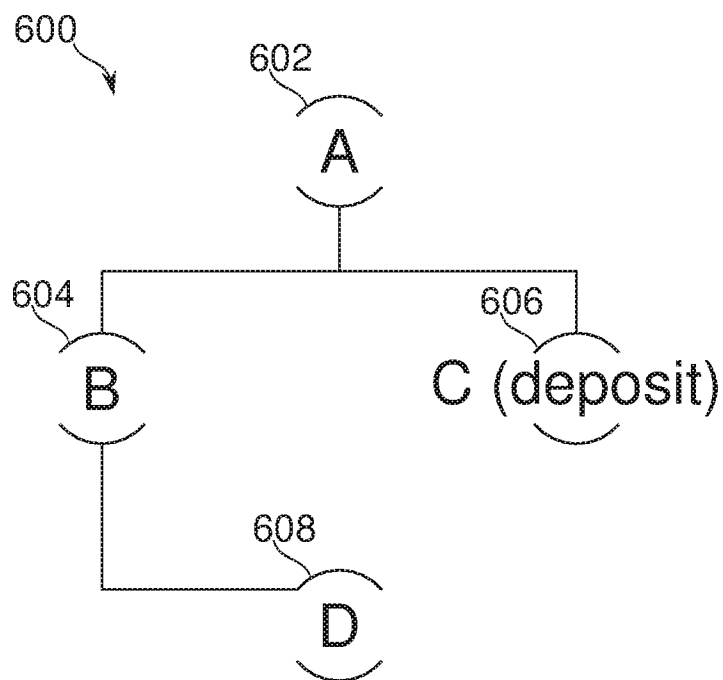

FIG. 7

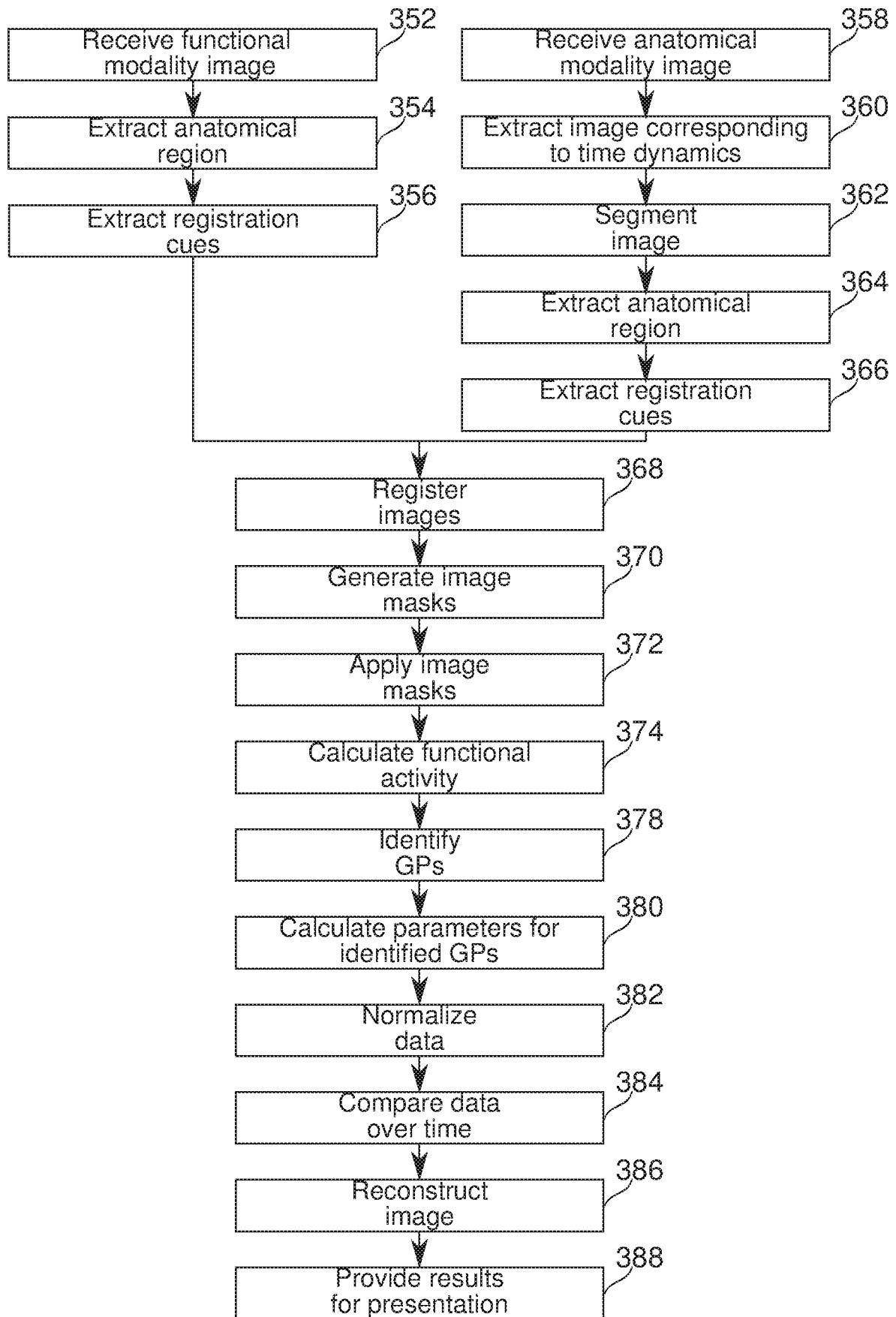

FIG. 8

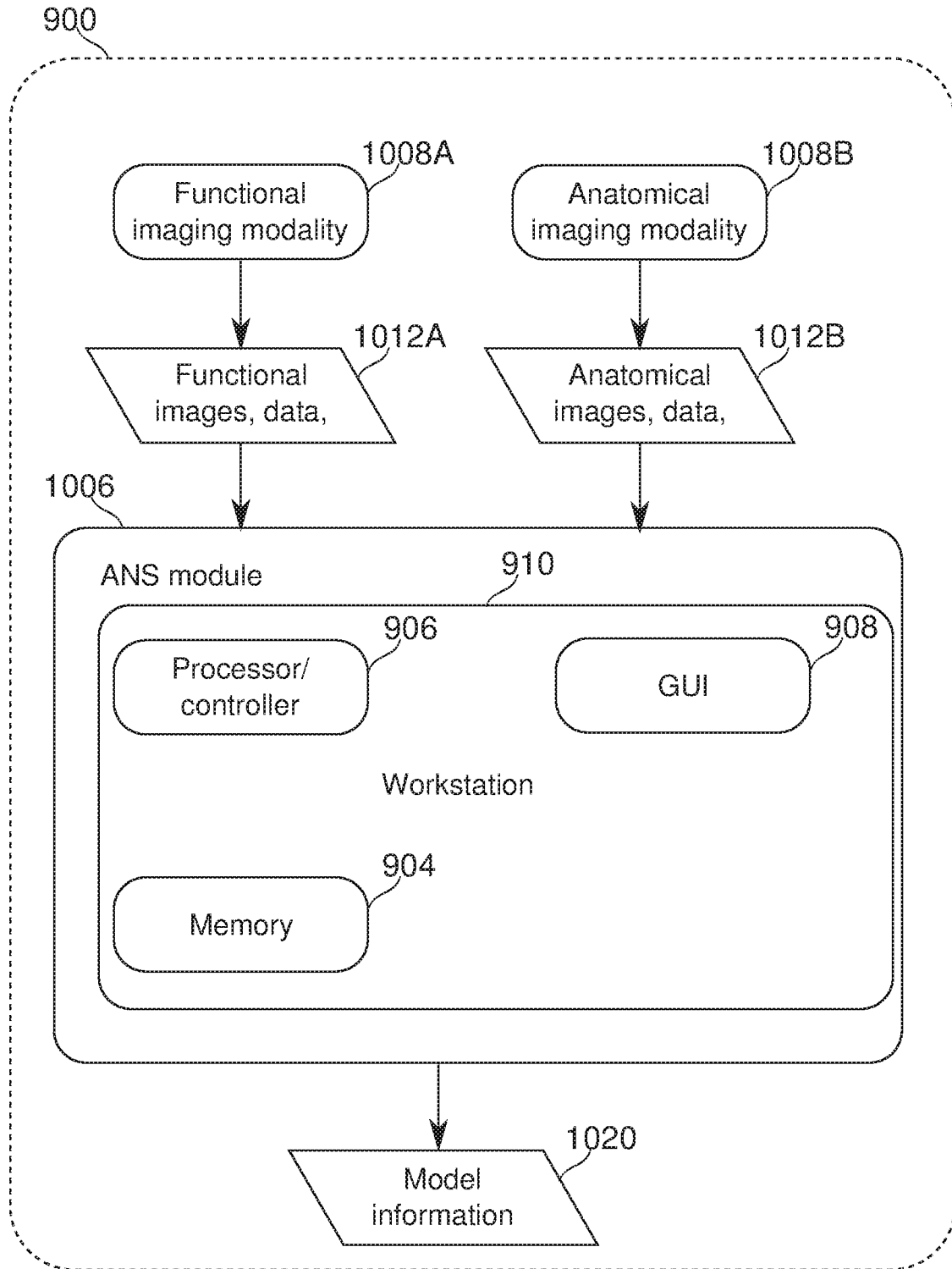
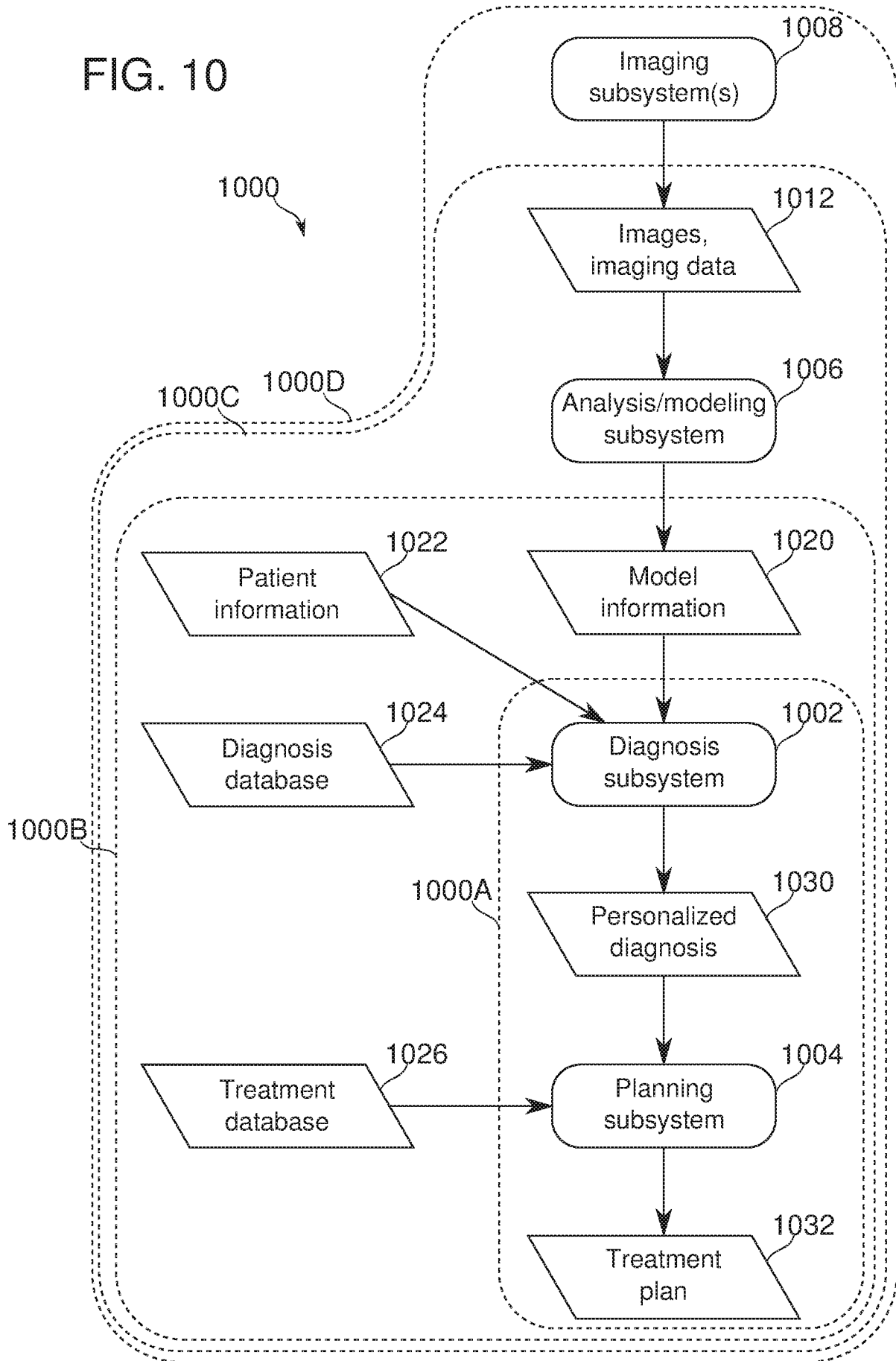

FIG. 9

FIG. 10



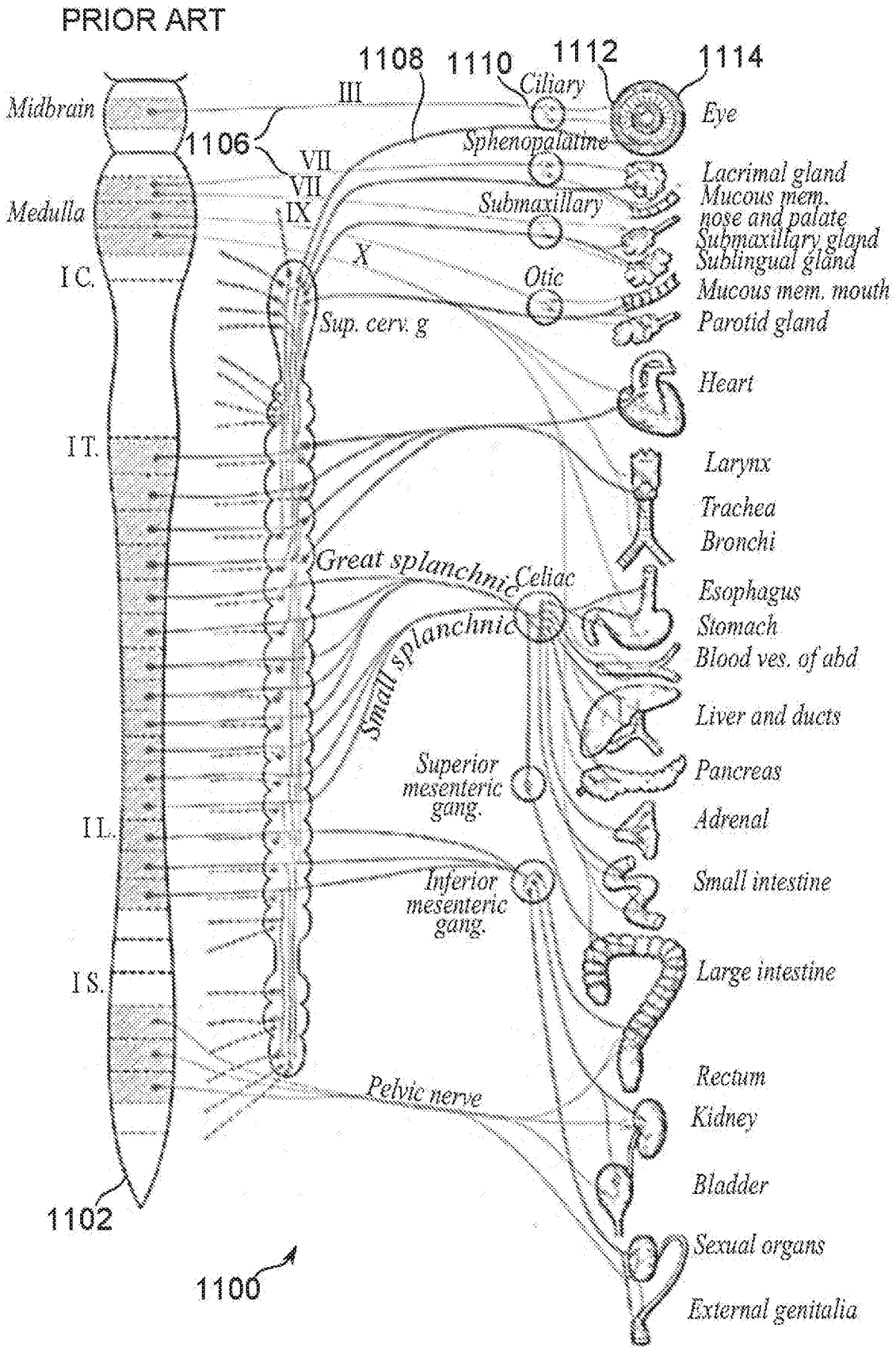

FIG. 11

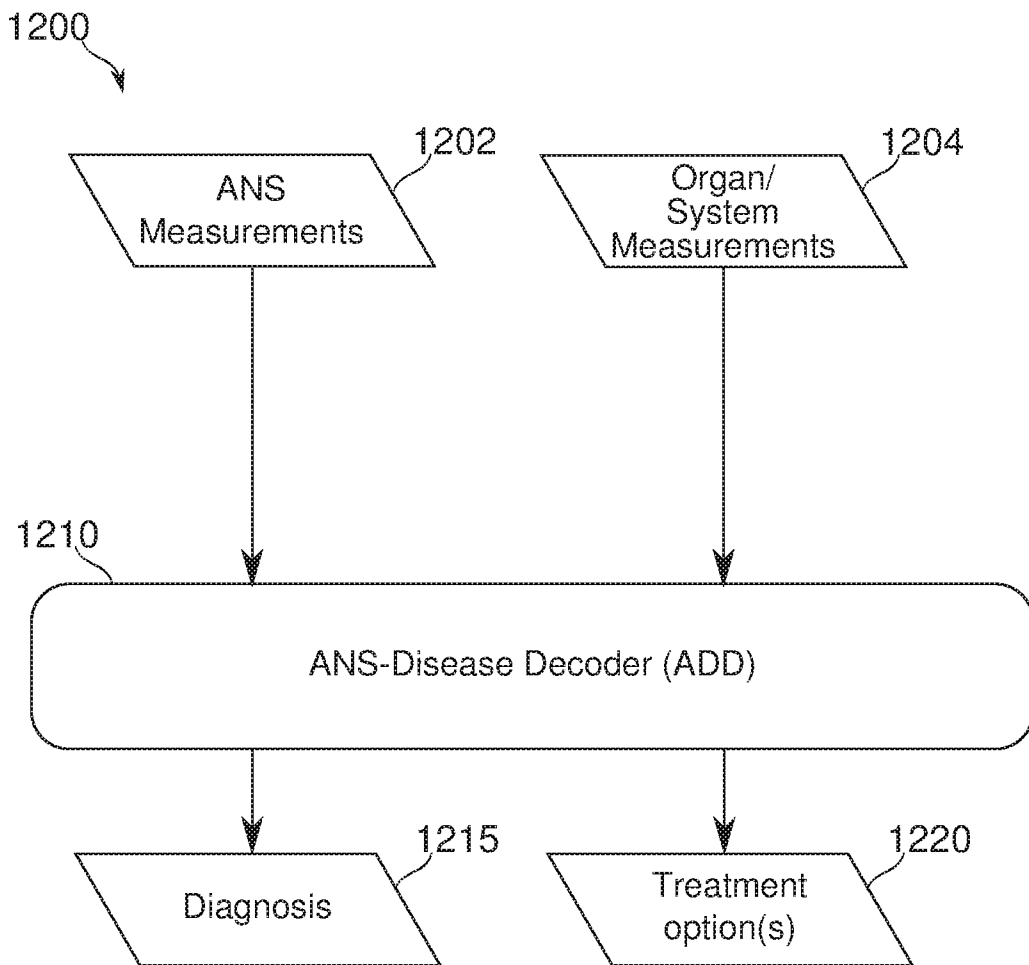

FIG. 12

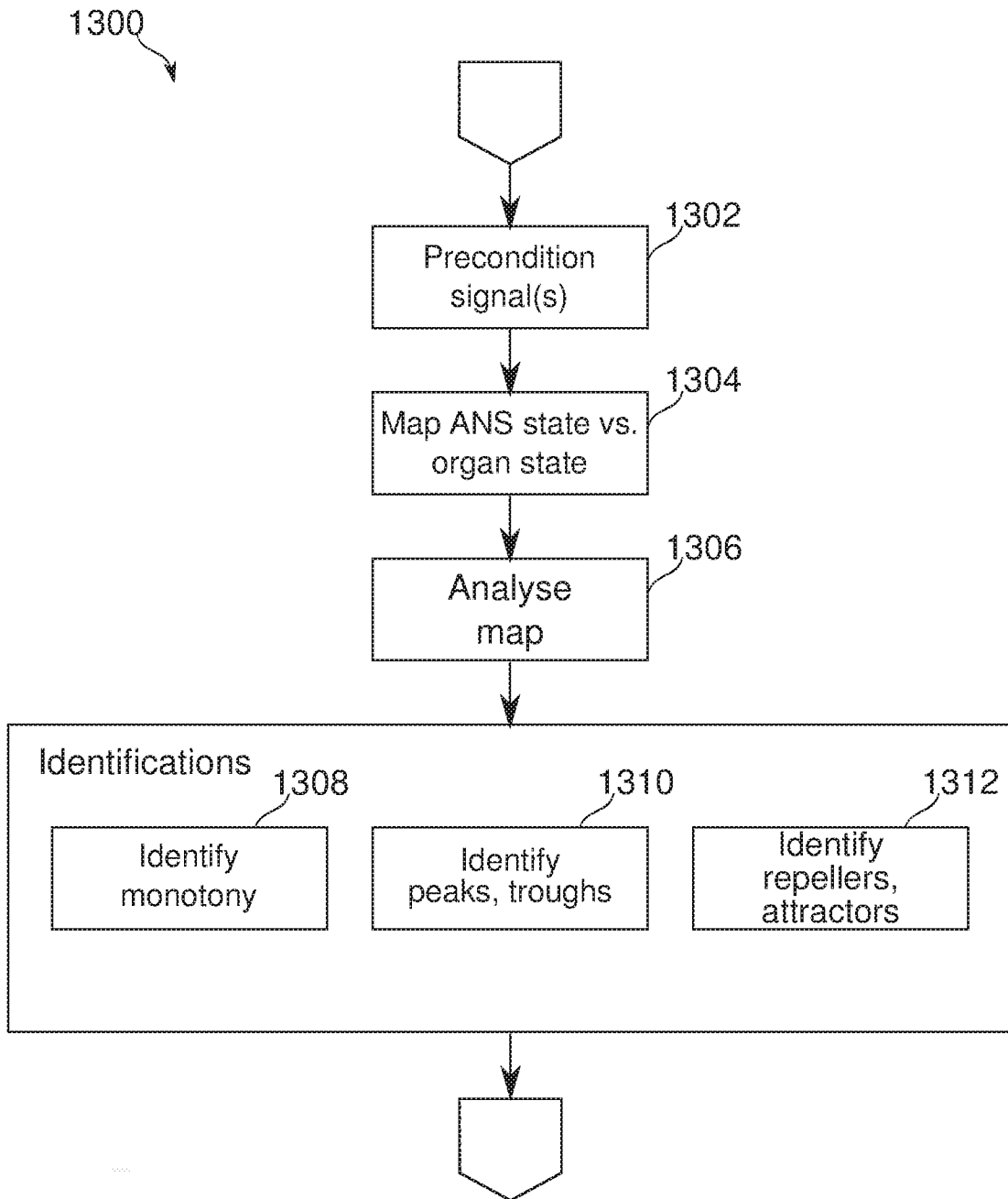

FIG. 13

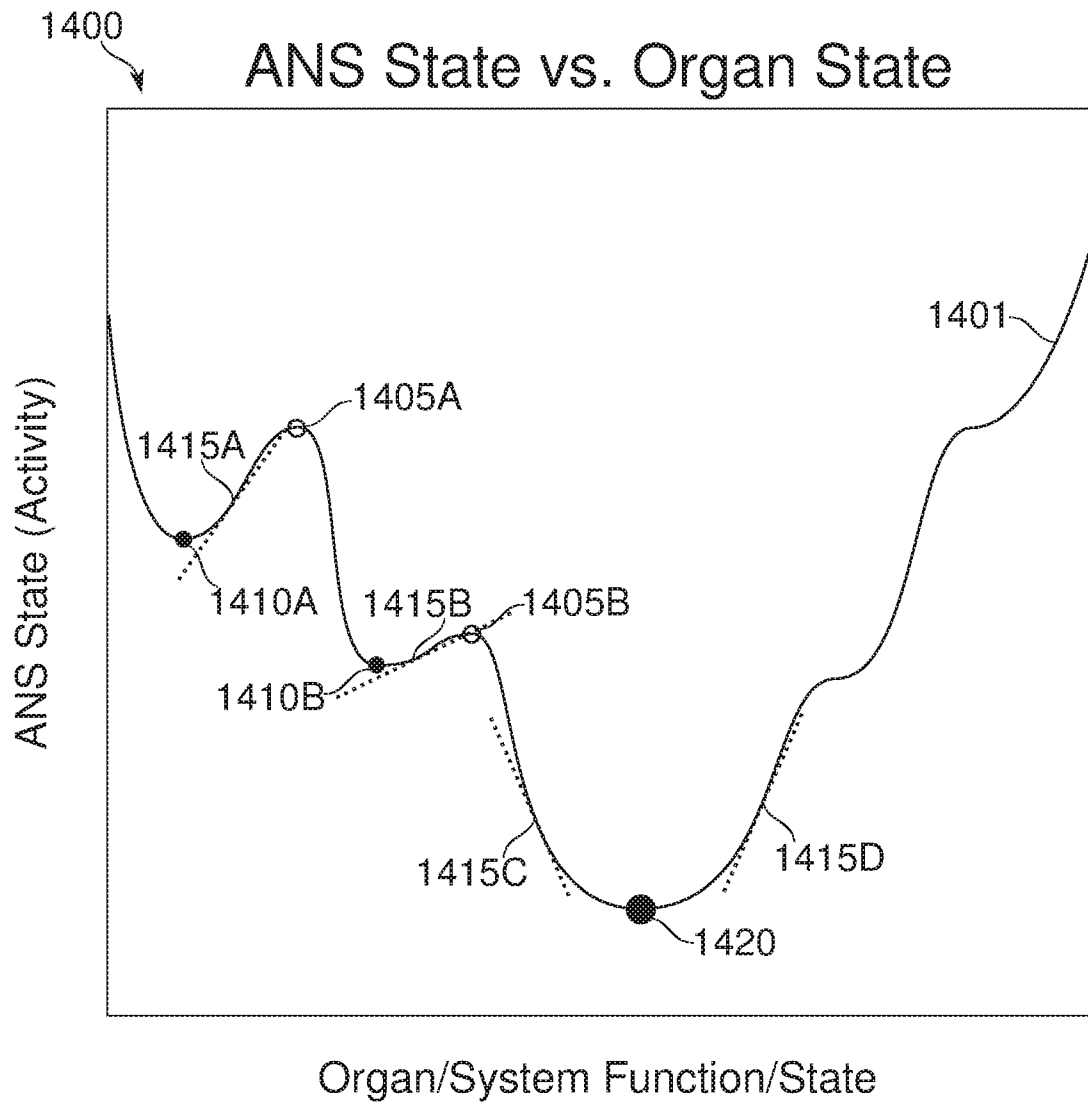

FIG. 14

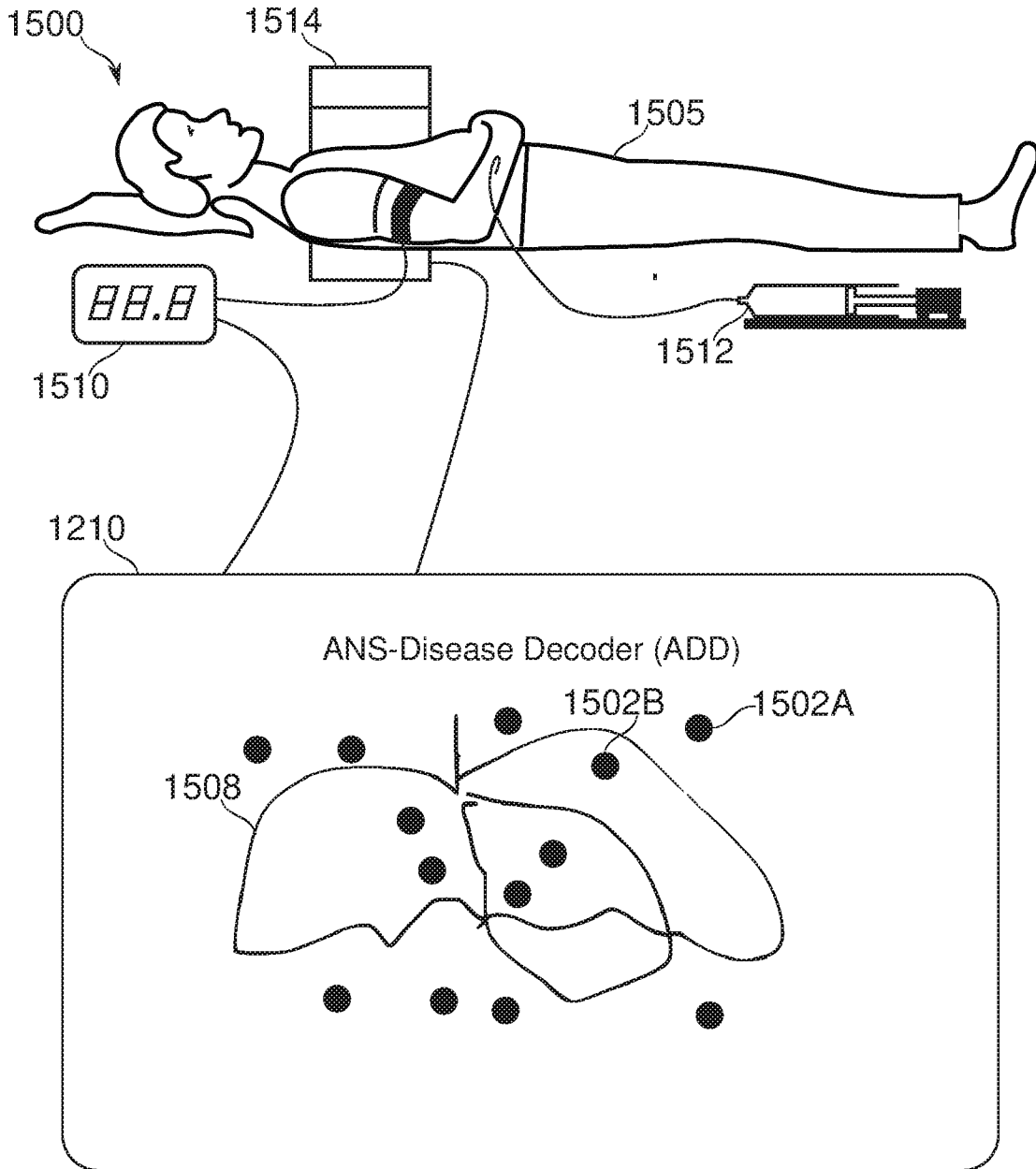

FIG. 15

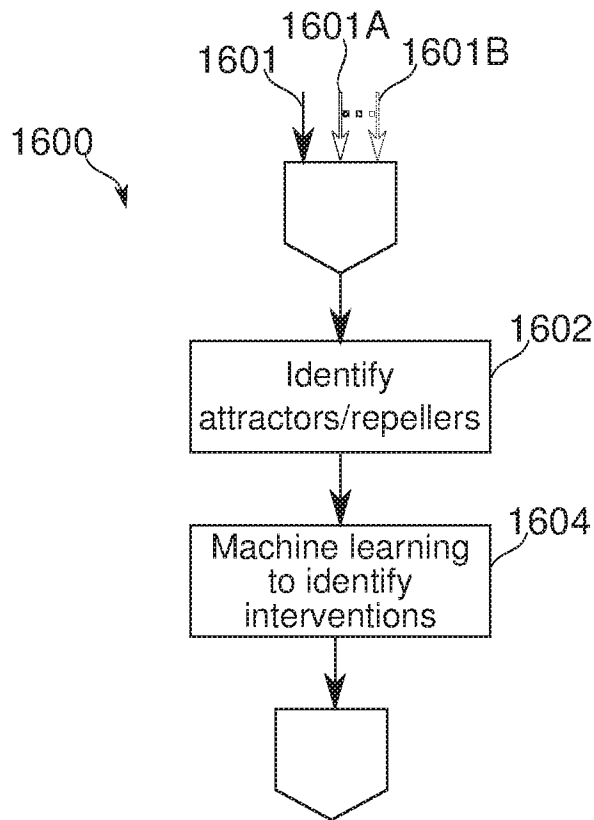

FIG. 16

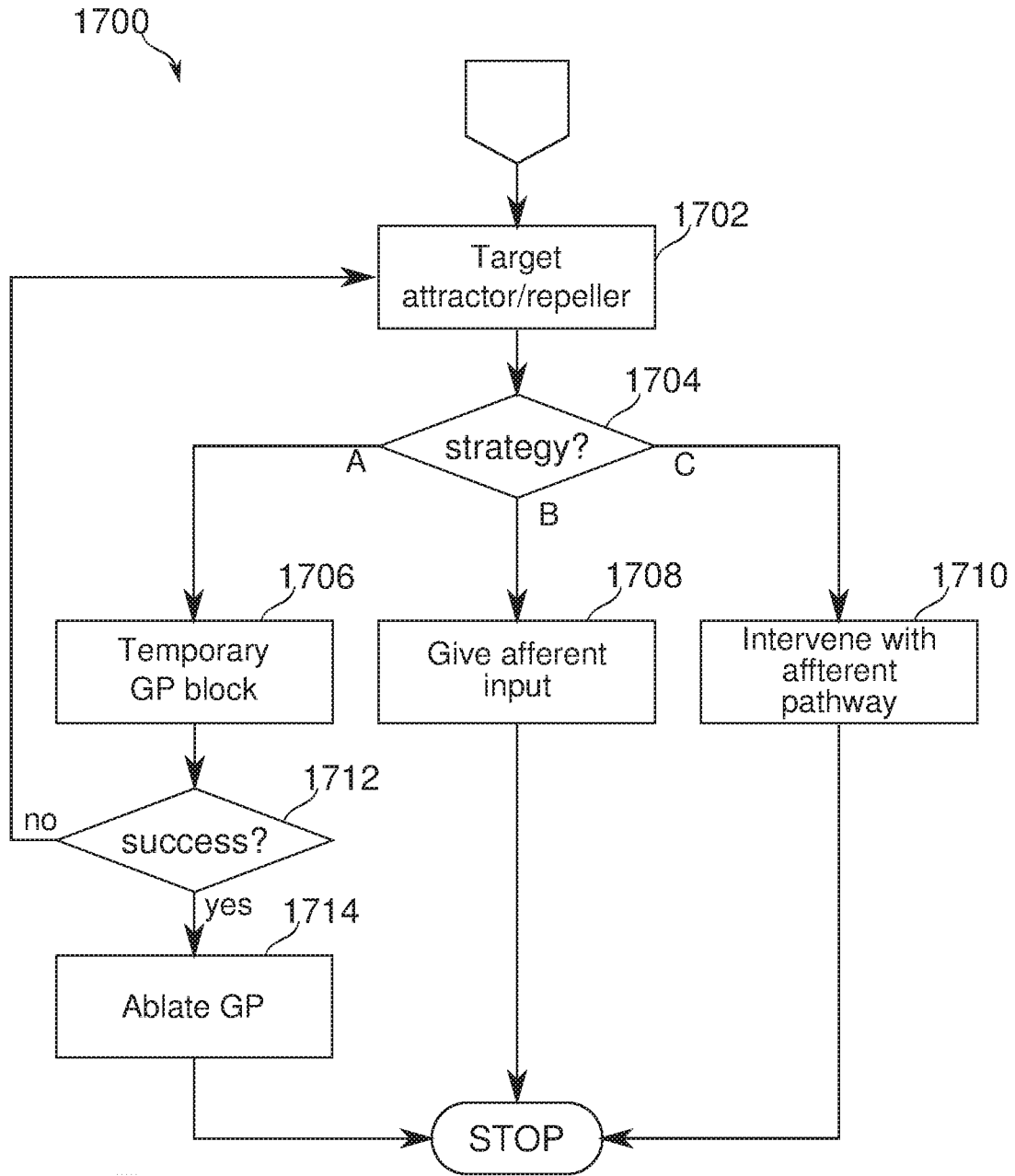

FIG. 17

专利名称(译)	用于诊断和治疗影响疾病的神经系统活动模式的装置和方法		
公开(公告)号	EP3041405A4	公开(公告)日	2017-07-19
申请号	EP2014842815	申请日	2014-09-08
[标]申请(专利权)人(译)	TYLERTON INT		
申请(专利权)人(译)	TYLERTON INTERNATIONAL INC.		
当前申请(专利权)人(译)	TYLERTON INTERNATIONAL INC.		
[标]发明人	BEN HAIM SHLOMO		
发明人	BEN-HAIM, SHLOMO		
IPC分类号	A61B5/00		
CPC分类号	G06T7/0012 G06T2207/10072 G06T2207/30048 A61B6/037 A61B6/506 A61B34/10 A61B2018/00577 A61N2/006 A61N2/02 G06T7/0014 G06T2207/10076 G06T2207/30016 G06T2207/30092		
优先权	61/875070 2013-09-08 US 61/875069 2013-09-08 US 61/875074 2013-09-08 US 61/925670 2014-01-10 US 61/925669 2014-01-10 US PCT/IL2014/050086 2014-01-24 WO PCT/IL2014/050088 2014-01-24 WO PCT/IL2014/050089 2014-01-24 WO PCT/IL2014/050090 2014-01-24 WO PCT/IL2014/050246 2014-03-11 WO 62/003108 2014-05-27 US 62/030740 2014-07-30 US 62/030972 2014-07-30 US 62/030917 2014-07-30 US		
其他公开文献	EP3041405A2		
外部链接	Espacenet		

摘要(译)

一种治疗心脏心律失常的方法，包括 (i) 确定心脏组织是否存活但神经支配减少; (ii) 消融组织以减少所述心脏中心律失常的发生率。可选地，所述确定包括检测心壁的缺少电活动的部分。任选地，至少一些可存活但缺乏神经控制的组织被消融，例如，以减少或避免心律失常。