



- (51) International Patent Classification: *A61B 5/00* (2006.01)
- (21) International Application Number: PCT/US2010/027912
- (22) International Filing Date: 19 March 2010 (19.03.2010)
- (25) Filing Language: English
- (26) Publication Language: English
- (30) Priority Data:

| | | |
|------------|----------------------------|----|
| 61/163,358 | 25 March 2009 (25.03.2009) | US |
| 12/722,279 | 11 March 2010 (11.03.2010) | US |
- (71) Applicant (for all designated States except US): **NELL-COR PURITAN BENNETT LLC** [US/US]; 6135 Gunbarrel Avenue, Boulder, Colorado 80301 (US).
- (72) Inventors; and
- (75) Inventors/Applicants (for US only): **MCKENNA, Edward** [US/US]; 4557 Starboard Drive, Boulder, Colorado 80301 (US). **BESKO, David** [US/US]; 4128 East 139th Place, Thornton, Colorado 80602 (US).
- (74) Agent: **SCHAUMANN, Dave**; 6135 Gunbarrel Avenue, Boulder, Colorado 80301 (US).
- (81) Designated States (unless otherwise indicated, for every kind of national protection available): AE, AG, AL, AM, AO, AT, AU, AZ, BA, BB, BG, BH, BR, BW, BY, BZ, CA, CH, CL, CN, CO, CR, CU, CZ, DE, DK, DM, DO, DZ, EC, EE, EG, ES, FI, GB, GD, GE, GH, GM, GT,

[Continued on next page]

(54) Title: MEDICAL SENSOR WITH COMPRESSIBLE LIGHT BARRIER AND TECHNIQUE FOR USING THE SAME

(57) Abstract: According to various embodiments, a medical sensor assembly may include compressible light barriers configured to prevent undesired light from being detected. The compressible light barriers may protrude from the surface of the sensor. However, when applied to the tissue, the compressible light barriers may be compressed to the point of being substantially flush with the tissue.

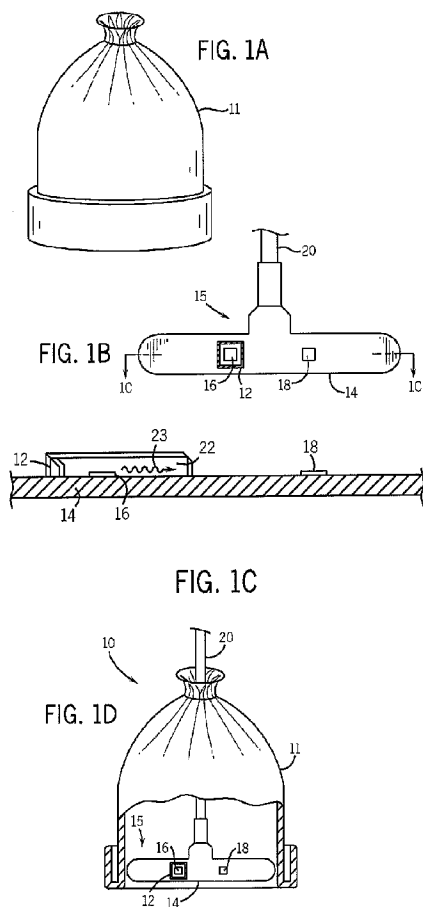

WO 2010/111127 A1



HN, HR, HU, ID, IL, IN, IS, JP, KE, KG, KM, KN, KP, KR, KZ, LA, LC, LK, LR, LS, LT, LU, LY, MA, MD, ME, MG, MK, MN, MW, MX, MY, MZ, NA, NG, NI, NO, NZ, OM, PE, PG, PH, PL, PT, RO, RS, RU, SC, SD, SE, SG, SK, SL, SM, ST, SV, SY, TH, TJ, TM, TN, TR, TT, TZ, UA, UG, US, UZ, VC, VN, ZA, ZM, ZW.

ZW), Eurasian (AM, AZ, BY, KG, KZ, MD, RU, TJ, TM), European (AT, BE, BG, CH, CY, CZ, DE, DK, EE, ES, FI, FR, GB, GR, HR, HU, IE, IS, IT, LT, LU, LV, MC, MK, MT, NL, NO, PL, PT, RO, SE, SI, SK, SM, TR), OAPI (BF, BJ, CF, CG, CI, CM, GA, GN, GQ, GW, ML, MR, NE, SN, TD, TG).

(84) Designated States (*unless otherwise indicated, for every kind of regional protection available*): ARIPO (BW, GH, GM, KE, LS, MW, MZ, NA, SD, SL, SZ, TZ, UG, ZM,

Published:

— *with international search report (Art. 21(3))*

MEDICAL SENSOR WITH COMPRESSIBLE LIGHT BARRIER AND TECHNIQUE FOR USING THE SAME

BACKGROUND

5 The present disclosure relates generally to medical devices and, more particularly, to sensors used for sensing physiological parameters of a patient.

 This section is intended to introduce the reader to aspects of the art that may be related to various aspects of the present disclosure, which are described and/or claimed below. This discussion is believed to be helpful in providing the reader
10 with background information to facilitate a better understanding of the various aspects of the present disclosure. Accordingly, it should be understood that these statements are to be read in this light, and not as admissions of prior art.

 In the field of medicine, doctors often desire to monitor certain physiological characteristics of their patients. Accordingly, a wide variety of devices have been
15 developed for monitoring many such physiological characteristics. Such devices provide doctors and other healthcare personnel with the information they need to provide the best possible healthcare for their patients. As a result, such monitoring devices have become an indispensable part of modern medicine.

 One technique for monitoring certain physiological characteristics of a
20 patient is commonly referred to as pulse oximetry, and the devices built based upon pulse oximetry techniques are commonly referred to as pulse oximeters. Pulse oximetry may be used to measure various blood flow characteristics, such as the blood-oxygen saturation of hemoglobin in arterial blood, the volume of individual blood pulsations supplying the tissue, and/or the rate of blood pulsations
25 corresponding to each heartbeat of a patient. In fact, the “pulse” in pulse oximetry refers to the time varying amount of arterial blood in the tissue during each cardiac cycle.

 Pulse oximeters typically utilize a non-invasive sensor that transmits light through a patient’s tissue and that photoelectrically detects the absorption and/or

scattering of the transmitted light in such tissue. One or more of the above physiological characteristics may then be calculated based upon the amount of light absorbed and/or scattered. More specifically, the light passed through the tissue is typically selected to be of one or more wavelengths that may be absorbed and/or scattered by the blood in an amount correlative to the amount of the blood constituent present in the blood. The amount of light absorbed and/or scattered may then be used to estimate the amount of blood constituent in the tissue using various algorithms.

Pulse oximetry readings involve placement of a sensor on a patient's tissue, typically via a lightly adhesive sensor, a clip-style sensor, or a sensor that may be fitted into a wearable garment, such as a hat or a headband. If the hat or headband is not closely fitted to the patient's tissue, ambient light may interfere with the sensor's light detection. Some outside light infiltration into the sensor may be avoided by fitting the sensor snugly against the patient's tissue. However, such a conforming fit may be difficult to achieve over a range of patient physiologies without adjustment or excessive attention on the part of medical personnel. Additionally, an overly tight fit may cause local exsanguination of the tissue around the sensor. Exsanguinated tissue, which is devoid of blood, may shunt the sensor light through the tissue, which may also result in increased measurement errors.

BRIEF DESCRIPTION OF THE DRAWINGS

Advantages of the disclosure may become apparent upon reading the following detailed description and upon reference to the drawings in which:

FIG. 1A illustrates a perspective view of a hat structure for holding a pulse oximetry sensor on a patient's tissue according to an embodiment;

FIG. 1B illustrates a perspective view of an exemplary pulse oximetry sensor body with an compressible light barrier that may be incorporated with the hat of FIG. 1A;

FIG. 1C illustrates a cross-sectional view of the pulse oximetry sensor body taken along line 1C-1C of FIG. 1B;

FIG. 1D illustrates a cutaway view of the hat of FIG. 1A with the pulse oximetry sensor with a compressible light barrier as shown in FIG. 1B and FIG. 1C;

FIG. 2 illustrates a perspective view of a forehead sensor with a compressible light barrier arranged in concentric circles according to an embodiment;

5 FIG. 3 illustrates a cross-sectional view of the sensor of FIG. 2 taken along line 3-3;

FIG. 4 illustrates a cross-sectional of a sensor with a compressible light barrier with light reflective and light absorptive surfaces according to an embodiment;

10 FIG. 5 illustrates a perspective view of a headband-style sensor with a compressible light barrier according to an embodiment;

FIG. 6 illustrates a pulse oximetry system coupled to a multi-parameter patient monitor and a sensor according to an embodiment; and

15 FIG. 7 is a block diagram of a pulse oximetry system according to an embodiment.

DETAILED DESCRIPTION OF SPECIFIC EMBODIMENTS

One or more specific embodiments of the present disclosure will be described below. In an effort to provide a concise description of these embodiments, not all features of an actual implementation are described in the specification. It should be appreciated that in the development of any such actual implementation, as in any engineering or design project, numerous implementation-specific decisions must be made to achieve the developers' specific goals, such as compliance with system-related and business-related constraints, which may vary from one implementation to another. Moreover, it should be appreciated that such a development effort might be complex and time consuming, but would nevertheless be a routine undertaking of design, fabrication, and manufacture for those of ordinary skill having the benefit of this disclosure.

20
25

Optical medical sensors are provided that reduce the amount of outside light that may impinge the detecting elements of a sensor. Such sensors may also reduce the amount of “shunted” light, i.e., light originating from light emitting elements of the sensor that impinges the detecting elements of a sensor without first passing
5 through tissue. Such sensors may incorporate surface features on the tissue-contacting surface of the sensor to influence the path of light from the undesired light sources and/or to direct such light away from the detecting elements of the sensor. Such sensors may absorb or reflect the light originating from these undesired light sources before such light can impinge the detecting elements of the sensor.

10 Pulse oximetry sensors are typically placed on a patient in a location that is normally perfused with arterial blood to facilitate measurement of the desired blood characteristics, such as arterial oxygen saturation measurement (SpO_2). The most common sensor sites include a patient’s fingertips, toes, earlobes, or forehead. Regardless of the placement of a sensor used for pulse oximetry, the reliability of the
15 pulse oximetry measurement is related to the accurate detection of transmitted light that has passed through the perfused tissue and that has not been supplemented by undesired light sources. Such supplementation and/or modulation of the signals transmitted to a monitor by the sensor can cause variability in the resulting pulse oximetry measurements. The contribution of ambient and/or shunted light may
20 affect the measurement of the particular blood constituent, such as SpO_2 .

In many cases, light from undesired light sources propagates along an optical path that is distinguishable from the optical path of the light that is related to a blood constituent. In a transmission-type sensor, the sensor’s emitter and detector lie on opposing sides of the tissue when the sensor is applied to a patient. The
25 optical path of the signal light, which is light originating from the emitter that properly passes through perfused tissue, is substantially in-line with an imaginary axis connecting the emitter and the detector. For reflectance-type sensors, the optical path of the emitted signal light is somewhat more complicated, as the light first enters the perfused tissue and then is scattered back to the detector. In both
30 transmission-type and reflectance-type sensors, shunted light and ambient light

generally propagate at angles substantially off-axis from the optical path of the signal light.

The sensors discussed below have compressible light barriers that act to divert shunted and/or ambient light away from the light detecting elements of a sensor. In an embodiment, an oximetry sensor with such compressible light barriers may be adapted for placement in a hat (for example, a neonatal stocking cap), a headband, or other wearable structure (*i.e.* a glove, a sock, a wristband) to apply the sensor on the body of the user. **FIGs. 1A-1D** illustrate an assembly drawing of an embodiment of a sensor assembly **10** including a wearable structure, which may be a hat **11**, as shown in **FIG. 1A**. A reflectance-type pulse oximetry sensor **15**, as shown in **FIG. 1B**, is adapted to be placed or adhered to the inside of the hat **11**. The sensor **15** may include a substrate **14** that may be made from any suitable material. In an embodiment, the substrate **14** is a foam or other conformable material. In one embodiment, the substrate **14** is black or dark in color to absorb stray light and further minimize any shunting of light between sensor and patient skin. The substrate **14** may include an adhesive material to secure the sensor directly to the tissue. In one embodiment, the sensor **15** may include an emitter **16** containing emitters for two or more wavelengths of lights and a detector **18** spaced apart from the emitter **16**. The sensor **15** also may include compressible light barrier **12**, discussed in more detail below, configured to block undesired light from reaching the detector **18**.

Also shown in **FIG. 1B** is a cable **20** for providing drive current to the LED component of the emitter **16**, and providing the detector signal to the medical device. In addition to providing the electrical connection to the downstream medical device, the cable **20** may provide shielding to protect the signals from the detector against external electrical interference. In addition, the sensor **15** may include suitable structures for providing electrical connections to the cable **20** and/or downstream medical device, such as a flex circuit, a Faraday shield, and leads connecting the optical components of the sensor **15** to the electrical components.

FIG. 1C is a cross-sectional side view showing the compressible light barrier **12** that substantially surrounds emitter **16**. The compressible light barrier **12**

may protrude from the surface 14 of the sensor 15. When the hat 11 is applied to the tissue, the force of the elastic band or knit of the hat 11 may provide sufficient force such that the compressible light barrier 12 is compressed against the tissue to form a seal. Any light from the emitter 16 on a path, represented by arrow 23, to shunt
5 directly to the detector 18 is blocked by the interior walls 22 of the compressible light barrier 12. Accordingly, light from the emitter 16 may be directed towards the tissue and away from the shunt path to the detector 18, which may improve the accuracy of measurements from the sensor 15.

As shown, the compressible light barrier 12 surrounds the emitter 16.
10 However, in embodiments the compressible light barrier 12 may surround the detector 18, or both the emitter 16 and the detector 18, or may be disposed in a region between the emitter 16 and the detector 18. In an embodiment, it may be advantageous for the footprint of the compressible light barrier 12 on the surface 14 to be minimized. For example, while the compressible light barrier 12 may act to
15 prevent unwanted light from reaching the detector, the compressible light barrier 12, because it protrudes from the surface 14, may also interfere with a conforming fit of the sensor 15 to the tissue. Accordingly, a balance between the light barrier properties and the conforming fit may be achieved by providing the compressible light barrier 12 on less than 25%, less than 20%, less than 15%, less than 10%, or
20 less than 5% of the surface 14. This may be achieved by providing the compressible light barrier 12 with relatively thin walls, or by surrounding only one of the emitter 16 and the detector 18 rather than both. In an embodiment, the compressible light barrier 12 surrounding the emitter 16 may have a different, or smaller, shape than the compressible light barrier 12 surrounding the detector 18. For example, it may be
25 advantageous to have a smaller compressible light barrier 12 surrounding the emitter 16 to more narrowly focus the light directed towards the tissue. In addition, the compressible light barrier 12 may be configured to protrude minimally from the surface 14. The compressible light barrier 12 may protrude from the surface 14 at least about 0.5mm, 1mm, 2mm, or 5mm in its uncompressed state. It should be
30 understood that the compressible light barrier 12, when compressed by the force of application of the sensor 15 to the tissue, may protrude only slightly from the surface 14. For example, the compressible light barrier 12 may protrude from the surface 14

about 0.5mm, 1mm, 2mm, in its uncompressed state. A compressible light barrier 12 that is 5mm in height in its uncompressed state may be compressed to a height of 2.5mm (50% of its uncompressed height) or 1.25mm (25% of its uncompressed height). Similarly, a compressible light barrier 12 that is 2mm in height in its uncompressed state may be compressed to a height of 1mm (50% of its uncompressed height) or 0.5mm (25% of its uncompressed height).

In an embodiment, the compressible light barrier 12 is formed from materials with low durometer or a high degree of compressibility, such as foams, silicone, polyvinyl chloride, or gels, for example, a material having a compression modulus of about 2.0 or less. The compression modulus for polyurethane foam is a function of the density of the foam and the structure of the foam. Generally, compression modulus increases as foam density increases. In embodiments, different chemical formulations and manufacturing processes may be used to create foams with different foam cell structures. Foams with high concentration of closed cells (closed-cell foam) typically have a higher compression modulus than foams with high concentration of open cells (open-cell foam). In an embodiment, compressibility may be measured by an Indention Load Deflection (ILD) test, which measures the load-bearing capacity of a standard specimen indented by a circular compressor foot of 50 square inches as 25% deflection. The sample is placed on a perforated plate (perforated plate has 1/4" holes on 3/4" centers) and is deflected twice to 25% of its original height and then allowed to relax for 10 +/- minutes. The height of the foam is then rechecked. The new height is determined and then the sample is deflected 25%, or to 75% of the crushed height. The foam is then held in this fashion for one minute and the load on the scale is then read. In one embodiment, the ratio (compression modulus) of the compressive force needed to indent the foam to 25% and 50%, respectively, of its thickness is determined. The greater the value of this ratio, the greater the degree of firmness that is offered by the foam. Low density foams have a compression modulus of around 1.20. In embodiments, the compression modulus of the compressible light barrier 12 may be less than about 2.0, less than about 1.5 or less than about 1.2.

The sensor assembly 10 is shown fully assembled in FIG. 1D. As shown, the sensor 15 is positioned on the interior of the hat 11 such that the emitter 16 and detector 18 may come into contact with the skin when the sensor assembly 10 is applied to a patient. The sensor 15 may be attached (*e.g.*, adhered or sewn into) to the inside band of the hat 11. In one embodiment, the hat 11 may include indicators to position the sensor 15 on a particular location on the patient's forehead, for example to position the sensor 15 on the lower forehead region, above the eyebrow, with the sensor optics (emitter 16 and detector 18) located above and predominantly lateral to or centered over the iris. The location of the reflectance sensor 15 in the hat allows appropriate placement of the sensor in the desired forehead location by a user. FIG. 1D shows that the cable 20 is positioned through a hole in the top of the hat 11. In an embodiment, the cable 20 may be adhered or otherwise constrained in the hat 11 so that the cable 20 generally is positioned away from the sensor 15 to avoid interfering with the patient's eyesight or bothering the patient.

In an embodiment, the force of the sensor 15 against the tissue, including any force provided by the compressible light barrier 12, may not exsanguinate the tissue. In one embodiment, it is contemplated that the force that hat 11 (or other wearable assembly, such as a headband or clip-style sensor) exerts on the tissue sufficient pressure so that the pressure exceeds the typical venous pressure of a patient, but does not exceed the diastolic arterial pressure. As the pulse oximetry measurements are related to arterial blood oxygen saturation and pulsation, and not venous blood pulsation, reducing the effect of the venous component in the tissue may enhance the sensitivity of the sensor to variations in the arterial blood signal. Thus, the sensor assembly 10 may apply a pressure greater than the venous pressure to squeeze excess pooled venous blood from the optically probed tissue. Yet, since the pressure applied by the sensor assembly 10 is designed to be less than the arterial pressure, the application of pressure to the tissue does not interfere with the arterial pulse signal. Typical venous pressure, diastolic arterial pressure, and systolic arterial pressure are less than 10-35 mmHg, 80 mmHg, and 120 mmHg, respectively. Accordingly, in certain embodiments, the sensor assembly 10 may be adjusted to overcome an average venous pressure of 15-35 mmHg. However, venous pressures may vary because of the location of the vascular bed and the patient's condition. For

example, low arterial diastolic blood pressure (about 30 mmHg) may occur in sick patients. In such embodiments, the sensor assembly **10** removes most of the venous pooling with by applying sufficient pressure to overcome light to moderate venous pressure (about 15 mmHg).

5 In one embodiment, the force applied to the tissue to overcome the venous pressure may be sufficient to compress the compressible light barrier **12** to an appropriate degree, for example to at least 50% of its original uncompressed height or at least 25% of its original uncompressed height, so that the light barrier properties remain intact. In another embodiment, if the force applied to the sensor is
10 increased, the compressible light barrier **12** may act as a pressure absorber, preventing the skin from becoming exsanguinated in the case of an inappropriately high pressure. In such an embodiment, the compressible light barrier **12** may then be compressed to an even greater degree, so that it lies substantially flush with the surface **14**.

15 It should be appreciated that the compressible light barrier **12** may be arranged in any suitable manner on the surface of the sensor **15** to prevent ambient or shunted light from reaching the detector **18**. In an embodiment, shown in **FIG. 2** and **FIG. 3**, compressible light barrier **12** may be arranged to surround the emitter **16** and the detector **18**. **FIG. 2** is a perspective view of an exemplary forehead sensor
20 **24** with a compressible light barrier **12** that includes concentric circles **26** that substantially surround an emitter **16** and a detector **18**, and **FIG. 3** is a cross-sectional view of the sensor **24** applied to a patient's forehead **28**. Such an arrangement of concentric circles **26** may be advantageous in forming a seal with the tissue **28**, thus creating a barrier against any ambient light or shunted light that may
25 leak into the sensor **24**. The ambient light, depicted by wavy arrows **30**, impinges the compressible light barrier **12** and is prevented from reaching the detector **18**. The optical path of the signal light, depicted by wavy arrow **32**, is substantially unaffected by the compressible light barrier **12**.

30 In one embodiment, the compressible light barrier **12** may include light absorbing materials, light reflecting materials, light refracting materials, or any combination thereof. For example, a surface, including all or part of a compressible

light barrier 12, may be formed from, coated with, or impregnated with such materials. It should also be appreciated that, as discussed above, the compressible light barrier 12 may contain such materials only on a tissue-contacting surface, or, in alternate embodiments, the sensor body may be constructed entirely from such materials in appropriate regions as described herein. As shown in FIG. 4, a cross-sectional view of a sensor 32, the compressible light barrier 12 surrounding the emitter 16 may include a light reflective surface 34 and a light absorptive surface 36. As shown, the light surface 34 may face the emitter 16, while the light absorptive surface 36 may be surfaces that do not face the emitter 16. Such an arrangement may allow off-angle light from the emitter 16 to be reflected back towards the tissue, which may help to increase the signal intensity received at the detector 18. In addition, dark or absorptive surfaces on other areas of the compressible light barrier 12 may absorb ambient light that leaks from the edges of the sensor 32. Similarly, the compressible light barrier 12 surrounding the detector 18 may include a light reflective surface 34 to help redirect light towards the detector 18 while absorptive surface 36 may absorb shunted or ambient light before it reaches the detector 18. Examples of light absorbing materials may include, but are not limited to, black or dark pigment, black or dark woven fabric or cloth, and infrared blockers. Examples of suitable light reflecting materials include white or silver pigment, metals, or mirrored surfaces. Further, the surface 40 of the sensor 32 may be light reflective or light absorptive.

It should also be appreciated that light absorbing materials may be adapted to absorb light at a particular wavelength. In certain embodiments, when light absorbing material is disposed between an emitter and a detector of a sensor, it may be advantageous to use light absorbing material that absorbs a wavelength emitted by the emitter in order to absorb shunted light from the emitter. For example, a light absorbing material may absorb at least about 50% of one or more wavelengths of light from the emitter, or may absorb a range of 50% to 95% of one or more wavelengths of light from the emitter. A light absorbing material may also absorb at least about 90% to at least 95% of one or more wavelengths of visible light and near-infrared light. In a specific embodiment, a pulse oximetry sensor may emit at least one wavelength of light in the wavelength range of 500nm-1000nm. For example, a

sensor may emit light and wavelengths of 660nm and 900nm, which are wavelengths that may be absorbed by dark pigment.

FIG. 5 illustrates an embodiment of a headband-based sensor assembly **50** that includes a medical sensor **44** and with a compressible light barrier **12**. The headband-based sensor assembly **50** may include a strap or band **52** that may be fitted around a patient's forehead tissue to contact the sensor **34** with the tissue. In certain embodiments, the sensor **44** may send feedback to a downstream monitor through cable **20** relating to one or more blood or tissue constituents.

A sensor or sensor assembly, illustrated generically as a sensor assembly **10**, may be used in conjunction with a pulse oximetry monitor **60**, as illustrated in **FIG. 6**. It should be appreciated that the cable **20** of the sensor assembly **10** may be coupled to the monitor **60** or it may be coupled to a transmission device to facilitate wireless transmission between the sensor assembly **10** and the monitor **60**. The monitor **60** may be any suitable pulse oximeter, such as those available from Nellcor Puritan Bennett LLC. Furthermore, to upgrade conventional pulse oximetry provided by the monitor **60** to provide additional functions, the monitor **60** may be coupled to a multi-parameter patient monitor **62** via a cable **64** connected to a sensor input port or via a cable **66** connected to a digital communication port.

FIG. 7 is a block diagram of an embodiment of a pulse oximeter **60** that may be configured to implement the embodiments of the present disclosure. Light from emitter **16** may pass into a blood perfused tissue, and may be scattered, and then detected by detector **18**. A sensor assembly **10** containing an emitter **16** and a detector **18** may also contain an encoder **70** which may be capable of providing signals indicative of the wavelength(s) of light source **16** to allow the oximeter to select appropriate calibration coefficients for calculating oxygen saturation. The encoder **70** may, in an embodiment, be a resistor.

In an embodiment, the sensor assembly **10** may be connected to a pulse oximetry monitor **60**. The monitor **60** may include a microprocessor **72** coupled to an internal bus **74**. Also connected to the bus may be a RAM memory **76** and a display **78**. A time processing unit (TPU) **80** may provide timing control signals to

light drive circuitry **82**, which controls when the emitter **16** is activated, and if multiple light sources are used, the multiplexed timing for the different light sources. TPU **80** may also control the gating-in of signals from detector **18** through an amplifier **83** and a switching circuit **84**. These signals are sampled at the proper
5 time, depending at least in part upon which of multiple light sources is activated, if multiple light sources are used. The received signal from the detector **18** may be passed through an amplifier **86**, a low pass filter **88**, and an analog-to-digital converter **90**. The digital data may then be stored in a queued serial module (QSM) **92**, for later downloading to RAM **76** or ROM **96** as QSM **92** fills up.

10 In an embodiment, based at least in part upon the received signals corresponding to the light received by detector **18**, microprocessor **72** may calculate the oxygen saturation using various algorithms. These algorithms may require coefficients, which may be empirically determined, and may correspond to the wavelengths of light used. The algorithms may be stored in a ROM **96** and accessed
15 and operated according to microprocessor **72** instructions. For example, the encoder **70** may communicate with decoder **71** to allow the microprocessor **72** to determine the appropriate coefficients.

In an embodiment of a two-wavelength system, the particular set of coefficients chosen for any pair of wavelength spectra may be determined by a value
20 indicated by the encoder **70** corresponding to a particular light source in a particular sensor assembly **10**. In one embodiment, multiple resistor values may be assigned to select different sets of coefficients, or the sets of coefficients may be stored on a digital medium. In another embodiment, the resistors are used to select from among the coefficients appropriate for an infrared source paired with either a near red
25 source or far red source. The selection between whether the near red or far red set will be chosen can be selected with a control input from control inputs **94**. Control inputs **94** may be, for instance, a switch on the pulse oximeter, a keyboard, or a port providing instructions from a remote host computer. Furthermore, any number of methods or algorithms may be used to determine a patient's pulse rate, oxygen
30 saturation or any other desired physiological parameter.

The sensor assembly **10** includes an emitter **16** and a detector **18** that may be of any suitable type. For example, the emitter **16** may be one or more light emitting diodes adapted to transmit one or more wavelengths of light in the red to infrared range, and the detector **18** may one or more photodetectors selected to receive light in the range or ranges emitted from the emitter **16**. Alternatively, an emitter **16** may also be a laser diode or a vertical cavity surface emitting laser (VCSEL). An emitter **16** and detector **18** may also include optical fiber sensing elements. An emitter **16** may include a broadband or "white light" source, in which case the detector could include any of a variety of elements for selecting specific wavelengths, such as reflective or refractive elements or interferometers. These kinds of emitters and/or detectors would typically be coupled to the rigid or rigidified sensor via fiber optics. Alternatively, a sensor assembly **10** may sense light detected from the tissue is at a different wavelength from the light emitted into the tissue. Such sensors may be adapted to sense fluorescence, phosphorescence, Raman scattering, Rayleigh scattering and multi-photon events or photoacoustic effects.

For pulse oximetry applications using either transmission or reflectance type sensors the oxygen saturation of the patient's arterial blood may be determined using two or more wavelengths of light, most commonly red and near infrared wavelengths. Similarly, in other applications, a tissue water fraction (or other body fluid related metric) or a concentration of one or more biochemical components in an aqueous environment may be measured using two or more wavelengths of light, most commonly near infrared wavelengths between about 1,000 nm to about 2,500 nm. It should be understood that, as used herein, the term "light" may refer to one or more of ultrasound, radio, microwave, millimeter wave, infrared, visible, ultraviolet, gamma ray or X-ray electromagnetic radiation, and may also include any wavelength within the radio, microwave, infrared, visible, ultraviolet, or X-ray spectra.

The emitter **16** and the detector **18**, and the compressible light barrier **12**, may be disposed on a sensor body, which may be made of any suitable material, such as plastic, foam, woven material, or paper. Alternatively, the emitter **16** and the detector **18** may be remotely located and optically coupled to the sensor assembly **10** using optical fibers. In the depicted embodiments, the sensor assembly **10** is coupled

to a cable that is responsible for transmitting electrical and/or optical signals to and from the emitter **16** and detector **18** of the sensor assembly **10**. The cable may be permanently coupled to the sensor assembly **10**, or it may be removably coupled to the sensor assembly **10**-- the latter alternative being more useful and cost efficient in situations where the sensor assembly **10** is disposable.

The sensor assembly **10** may be a "transmission type" sensor. Transmission type sensors include an emitter **16** and detector **18** that are typically placed on opposing sides of the sensor site. If the sensor site is a fingertip, for example, the sensor assembly **10** is positioned over the patient's fingertip such that the emitter **16** and detector **18** lie on either side of the patient's nail bed. In other words, the sensor assembly **10** is positioned so that the emitter **16** is located on the patient's fingernail and the detector **18** is located 180° opposite the emitter **16** on the patient's finger pad. During operation, the emitter **16** shines one or more wavelengths of light through the patient's fingertip and the light received by the detector **18** is processed to determine various physiological characteristics of the patient. In each of the embodiments discussed herein, it should be understood that the locations of the emitter **16** and the detector **18** may be exchanged. For example, the detector **18** may be located at the top of the finger and the emitter **16** may be located underneath the finger. In either arrangement, the sensor assembly **10** will perform in substantially the same manner.

Reflectance type sensors also operate by emitting light into the tissue and detecting the light that is transmitted and scattered by the tissue. However, reflectance type sensors include an emitter **16** and detector **18** that are typically placed on the same side of the sensor site. For example, a reflectance type sensor may be placed on a patient's fingertip or forehead such that the emitter **16** and detector **18** lie side-by-side. Reflectance type sensors detect light photons that are scattered back to the detector **18**. A sensor assembly **10** may also be a "transflectance" sensor, such as a sensor that may subtend a portion of a baby's heel.

While the disclosure may be susceptible to various modifications and alternative forms, specific embodiments have been shown by way of example in the drawings and have been described in detail herein. However, it should be

understood that the embodiments provided herein are not intended to be limited to the particular forms disclosed. Indeed, the disclosed embodiments may not only be applied to measurements of blood oxygen saturation, but these techniques may also be utilized for the measurement and/or analysis of other blood constituents. For

5 example, using the same, different, or additional wavelengths, the present techniques may be utilized for the measurement and/or analysis of carboxyhemoglobin, methemoglobin, total hemoglobin, fractional hemoglobin, intravascular dyes, and/or water content. Rather, the various embodiments may cover all modifications, equivalents, and alternatives falling within the spirit and scope of the disclosure as

10 defined by the following appended claims

CLAIMS

What is claimed is:

1. An apparatus comprising:
 - a stocking cap capable of being applied to a patient's head;
 - 5 a substrate disposed adjacent the stocking cap;
 - a light emitter disposed on the substrate;
 - a light detector disposed on the substrate;
 - a cable disposed on the substrate, wherein the cable extends from the substrate through an open portion of the stocking cap configured to be proximate to a top of the stocking cap when the stocking cap is applied to the patient; and
 - 10 a compressible protrusion disposed on the substrate, wherein the compressible protrusion is configured to substantially surround at least one of the emitter or the detector.
2. The apparatus of claim 1, wherein the compressible protrusion protrudes at least about 1 mm from the substrate.
- 15 3. The apparatus of claim 1, wherein the compressible protrusion protrudes substantially orthogonally from the substrate.
4. The sensor, as set forth in claim 1, comprising a second compressible protrusion that substantially surrounds the detector.
- 20 5. The sensor, as set forth in claim 1, wherein the compressible protrusion comprises a light reflecting material on a first surface and a light absorbing material on a second surface.
6. The sensor, as set forth in claim 5, wherein the first surface faces the emitter and the second surface opposes the emitter.
- 25

7. The sensor, as set forth in claim 1, wherein the compressible protrusion comprises a foam or gel.
8. The sensor, as set forth in claim 1, wherein the compressible protrusion is disposed on less than 10% of a surface of the substrate.
- 5 9. The apparatus of claim 1, wherein the stocking cap comprises a stocking cap capable of being placed on the head of a neonate.
- 10 10. The apparatus of claim 1, wherein the stocking cap is configured to apply a pressure less than about 35 mm Hg to the patient's head.
11. The apparatus of claim 1, wherein the compressible protrusion is
10 compressed to less than about 50% of its uncompressed height when the stocking cap is applied to the patient's head.
12. The apparatus of claim 1, the compressible protrusion is compressed to a height of less than 2.5mm when the stocking cap is applied to the patient's head.
13. A pulse oximetry system comprising:
15 a pulse oximetry monitor; and
a sensor assembly capable of being operatively coupled to the monitor, the sensor assembly comprising:
a light emitter and a light detector disposed on a substrate;
a compressible protrusion disposed on the substrate in an area between the
20 emitter and the detector, wherein the compressible protrusion does not substantially exsanguinate the patient's tissue when the sensor is assembly is applied to a patient's tissue; and
a cable disposed on the substrate, wherein the cable is configured to be coupled to the monitor.
- 25 14. The system, as set forth in claim 13, wherein the sensor assembly comprises a headband.

15. The system, as set forth in claim 13, wherein the compressible protrusion is configured to be compressed substantially flush with the tissue at an applied pressure of greater than 35 mm Hg.
16. The system, as set forth in claim 13, wherein the compressible protrusion is configured to be compressed substantially flush with the tissue at an applied pressure of greater than about 80 mm Hg.
17. The system, as set forth in claim 13, wherein the compressible protrusion is compressed to about 50% of its uncompressed height when the substrate is applied to the tissue.
18. The system, as set forth in claim 13, wherein the compressible protrusion is compressed to a height of less than 2.5mm when the substrate is applied to the tissue.
19. A sensor comprising:
- a sensor body adapted to operate in a reflectance mode;
 - an emitter disposed on the sensor body, wherein the emitter is configured to deliver a first light into a tissue;
 - a detector disposed on the sensor body, wherein the detector is configured to detect the first light; and
 - a compressible protrusion disposed on a tissue-contacting surface of the substrate, wherein the compressible protrusion is configured to reduce the amount of a second light impinging the detector at an incident angle substantially in-line with an imaginary axis connecting the emitter and the detector, and wherein the compressible protrusion has a compression modulus of less than about 2.0.
20. The sensor of claim 19, wherein the sensor comprises at least one of a pulse oximetry sensor or a sensor for measuring a water fraction.
21. The sensor of claim 19, wherein the compressible protrusion is disposed in a region between the emitter and the detector.

22. The sensor of claim 19, wherein the compressible protrusion comprises, silicone, polyvinylchloride, a foam or a gel.

23. The sensor of claim 19, wherein the compressible protrusion is configured to be compressed to 25% of its uncompressed height when the sensor is applied to a patient.

24. The sensor of claim 19, wherein the compressible protrusion is compressed from an uncompressed height greater than 5mm to a compressed height of less than 2.5mm when the sensor is applied to a patient.

25. The sensor of claim 19, wherein the compressible protrusion is compressed from an uncompressed height greater than 2mm to a compressed height of less than 1mm when the sensor is applied to a patient.

FIG. 1A

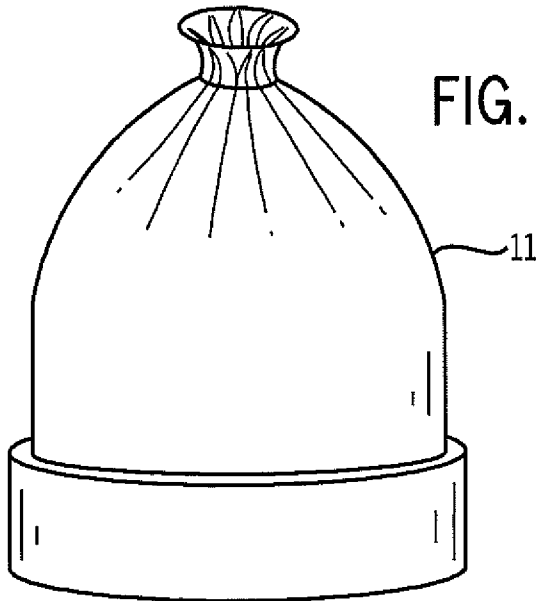

FIG. 1B

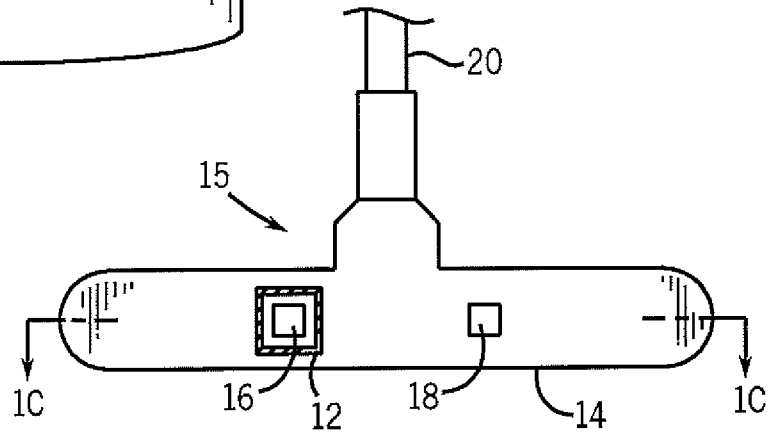
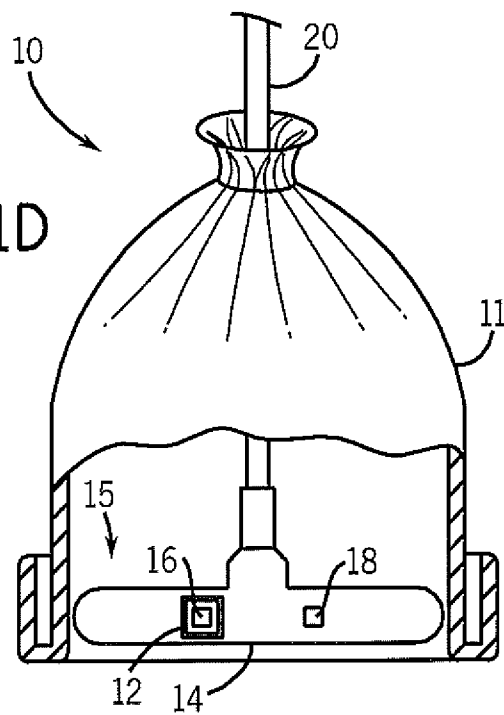

FIG. 1D



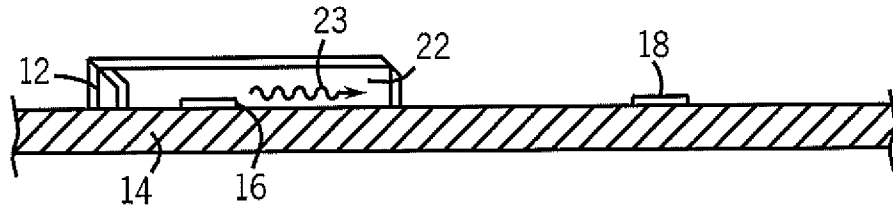

FIG. 1C

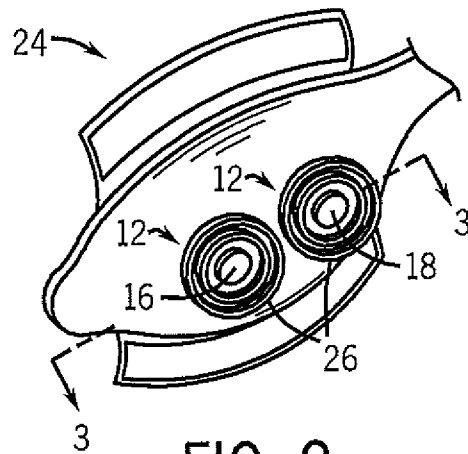

FIG. 2

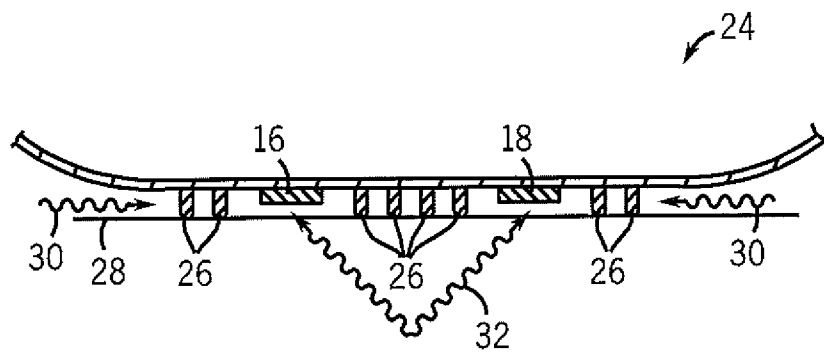

FIG. 3

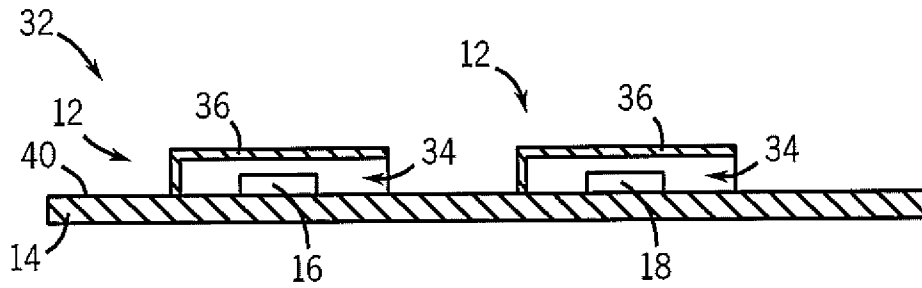

FIG. 4

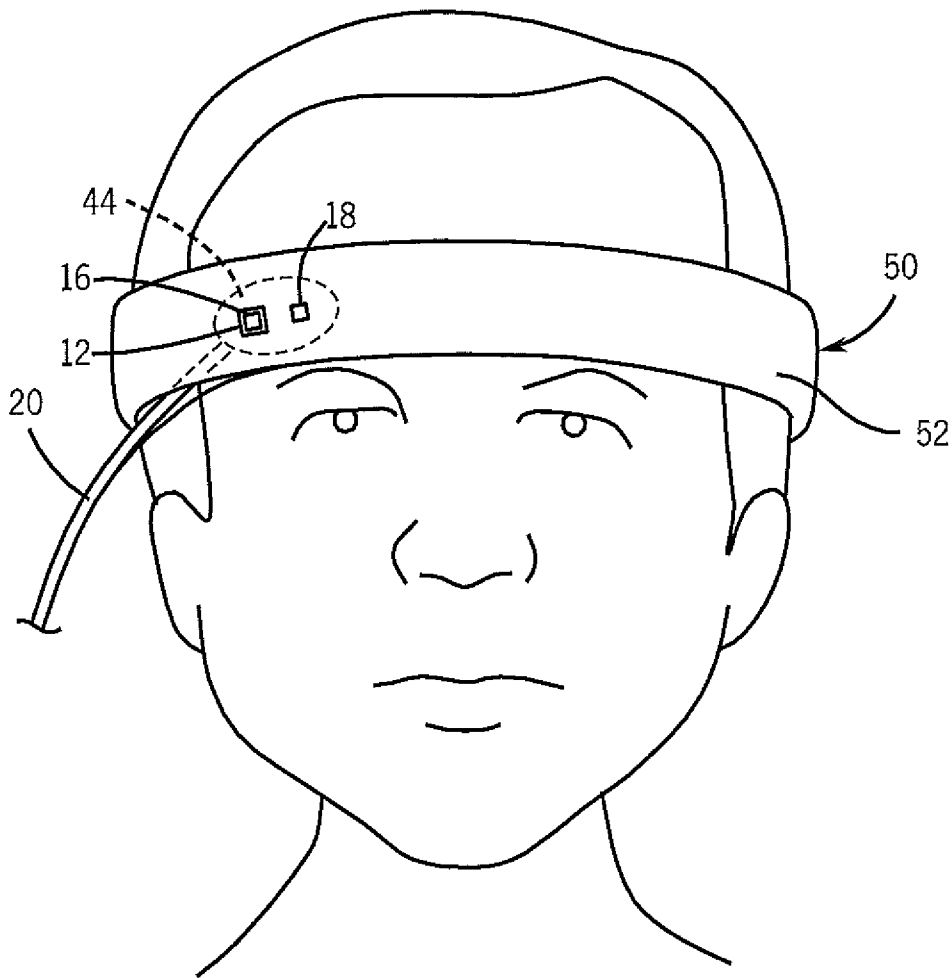

FIG. 5

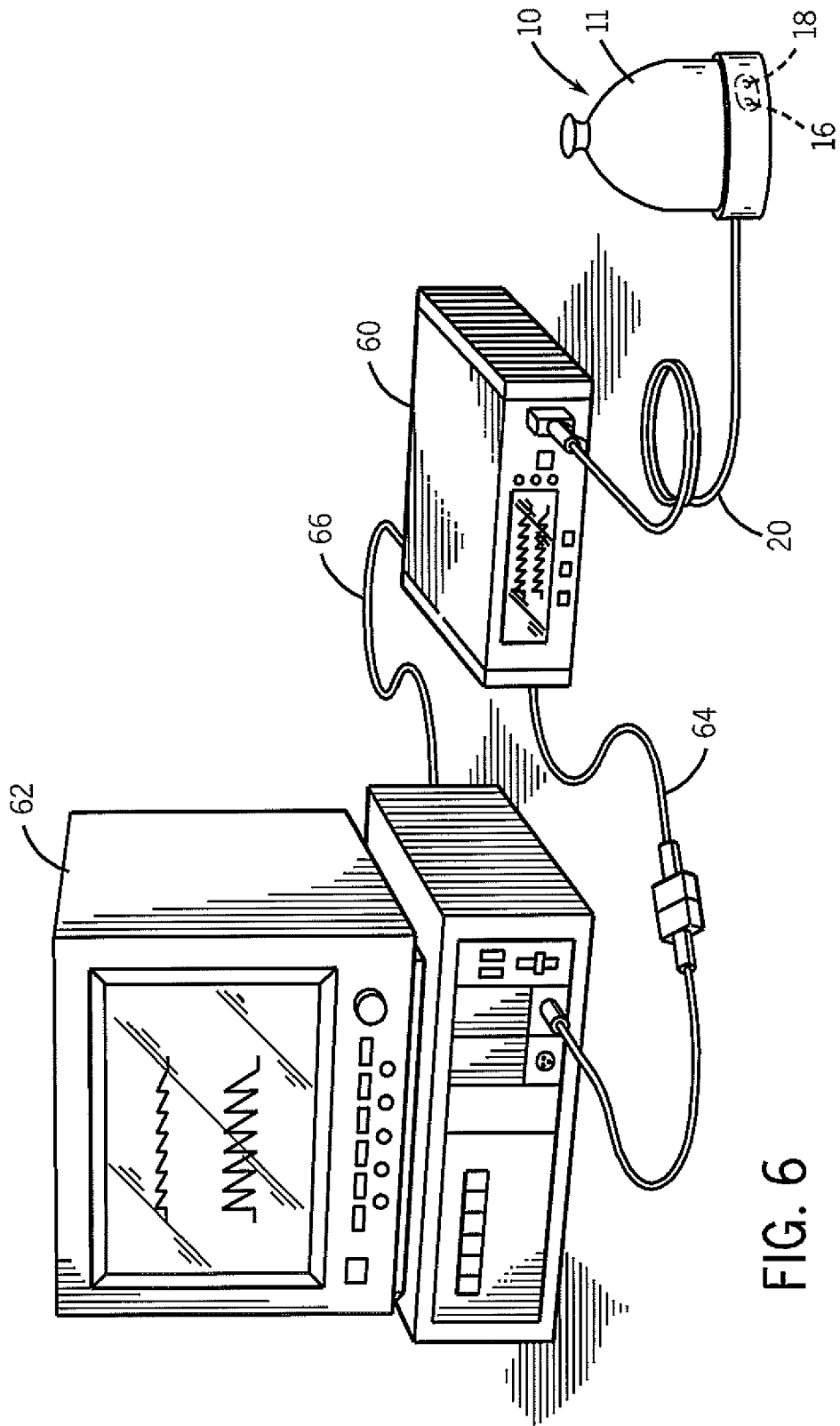

FIG. 6

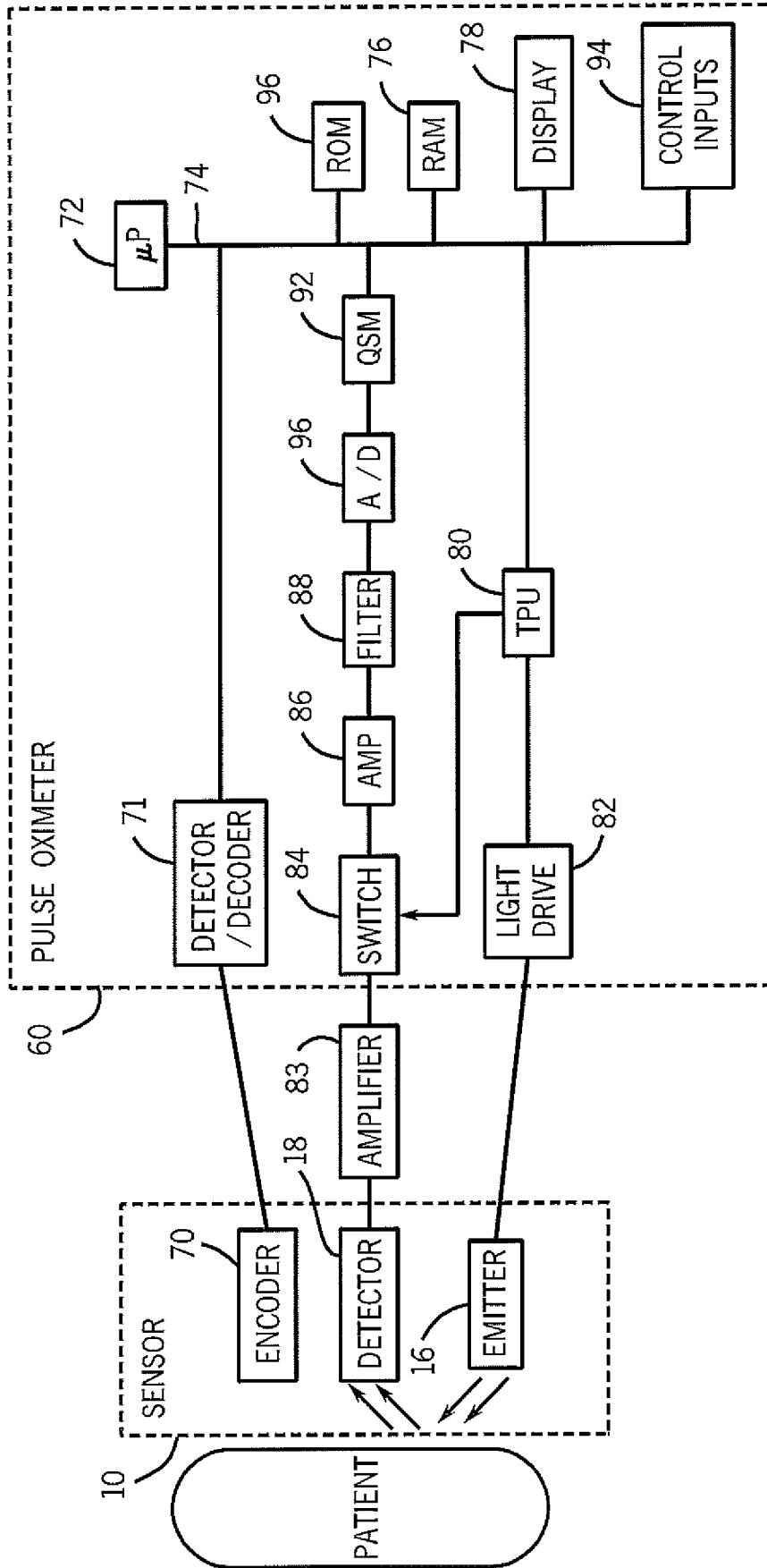

FIG. 7

INTERNATIONAL SEARCH REPORT

International application No
PCT/US2010/027912

A. CLASSIFICATION OF SUBJECT MATTER

INV. A61B5/00

ADD.

According to International Patent Classification (IPC) or to both national classification and IPC

B. FIELDS SEARCHED

Minimum documentation searched (classification system followed by classification symbols)

A61B

Documentation searched other than minimum documentation to the extent that such documents are included in the fields searched

Electronic data base consulted during the international search (name of data base and, where practical, search terms used)

EPO-Internal

C. DOCUMENTS CONSIDERED TO BE RELEVANT

| Category* | Citation of document, with indication, where appropriate, of the relevant passages | Relevant to claim No. |
|-----------|--|-----------------------|
| Y | US 2006/264722 A1 (HANNULA DON [US] ET AL) 23 November 2006 (2006-11-23) the whole document | 1-12 |
| X | US 2007/073117 A1 (RARIDAN WILLIAM B JR [US] RARIDAN JR WILLIAM B [US]) 29 March 2007 (2007-03-29) | 13-25 |
| Y | paragraphs [0053], [0059], [0060], [0064] figures 4a,4b | 1-12 |
| X | US 2002/161290 A1 (CHANCE BRITTON [US]) 31 October 2002 (2002-10-31) paragraph [0022] - paragraph [0029] paragraph [0114] - paragraph [0122] claims 1-13 figures 6a-c,7 | 13-25 |
| | ----- -/-- | |

Further documents are listed in the continuation of Box C.

See patent family annex.

* Special categories of cited documents :

"A" document defining the general state of the art which is not considered to be of particular relevance

"E" earlier document but published on or after the international filing date

"L" document which may throw doubts on priority claim(s) or which is cited to establish the publication date of another citation or other special reason (as specified)

"O" document referring to an oral disclosure, use, exhibition or other means

"P" document published prior to the international filing date but later than the priority date claimed

"T" later document published after the international filing date or priority date and not in conflict with the application but cited to understand the principle or theory underlying the invention

"X" document of particular relevance; the claimed invention cannot be considered novel or cannot be considered to involve an inventive step when the document is taken alone

"Y" document of particular relevance; the claimed invention cannot be considered to involve an inventive step when the document is combined with one or more other such documents, such combination being obvious to a person skilled in the art.

"&" document member of the same patent family

Date of the actual completion of the international search

12 May 2010

Date of mailing of the international search report

25/05/2010

Name and mailing address of the ISA/

European Patent Office, P.B. 5818 Patentlaan 2
NL - 2280 HV Rijswijk
Tel. (+31-70) 340-2040,
Fax: (+31-70) 340-3016

Authorized officer

Bengtsson, Johan

INTERNATIONAL SEARCH REPORT

International application No
PCT/US2010/027912

C(Continuation). DOCUMENTS CONSIDERED TO BE RELEVANT

| Category* | Citation of document, with indication, where appropriate, of the relevant passages | Relevant to claim No. |
|-----------|--|-----------------------|
| X | EP 0 573 137 A2 (ALZA CORP [US]) 8 December 1993 (1993-12-08) column 11, line 4 - line 19 figure 4 ----- | 13-25 |

INTERNATIONAL SEARCH REPORT

Information on patent family members

| |
|---|
| International application No PCT/US2010/027912 |
|---|

| Patent document cited in search report | A1 | Publication date | Patent family member(s) | Publication date |
|--|----|------------------|---|--|
| US 2006264722 | A1 | 23-11-2006 | US 2006264723 A1 US 2006264724 A1 US 2006264725 A1 | 23-11-2006 23-11-2006 23-11-2006 |
| | | | | |
| US 2007073117 | A1 | 29-03-2007 | US 2007073123 A1 US 2007073126 A1 WO 2007041335 A1 | 29-03-2007 29-03-2007 12-04-2007 |
| | | | | |
| US 2002161290 | A1 | 31-10-2002 | NONE | |
| | | | | |
| EP 0573137 | A2 | 08-12-1993 | AT 346643 T AT 229299 T DE 69332554 D1 DE 69332554 T2 DE 69334093 T2 DK 573137 T3 ES 2275803 T3 ES 2188590 T3 PT 573137 E | 15-12-2006 15-12-2002 23-01-2003 02-10-2003 06-06-2007 27-01-2003 16-06-2007 01-07-2003 31-03-2003 |
| | | | | |

| | | | |
|----------------|---|---------|------------|
| 专利名称(译) | 具有可压缩光栅的医疗传感器及其使用技术 | | |
| 公开(公告)号 | EP2410905A1 | 公开(公告)日 | 2012-02-01 |
| 申请号 | EP2010711114 | 申请日 | 2010-03-19 |
| [标]申请(专利权)人(译) | 内尔科尔普里坦贝内特公司 | | |
| 申请(专利权)人(译) | NELLCOR PURITAN BENNETT LLC | | |
| 当前申请(专利权)人(译) | COVIDIEN LP | | |
| [标]发明人 | MCKENNA EDWARD BESKO DAVID | | |
| 发明人 | MCKENNA, EDWARD BESKO, DAVID | | |
| IPC分类号 | A61B5/00 | | |
| CPC分类号 | A61B5/1455 A61B5/14552 A61B5/6814 A61B2562/146 A61B2562/164 | | |
| 优先权 | 61/163358 2009-03-25 US 12/722279 2010-03-11 US | | |
| 外部链接 | Espacenet | | |

摘要(译)

根据各种实施例，医疗传感器组件可包括可压缩光屏障，其配置成防止检测到不期望的光。可压缩光栅可以从传感器的表面突出。然而，当应用于组织时，可压缩光屏障可被压缩到与组织基本齐平的程度。