

(19) World Intellectual Property Organization  
International Bureau



(43) International Publication Date  
1 July 2010 (01.07.2010)

PCT

(10) International Publication Number  
WO 2010/075547 A2

- (51) International Patent Classification:  
A61N 7/00 (2006.01) A61B 18/00 (2006.01)
- (21) International Application Number:  
PCT/US2009/069467
- (22) International Filing Date:  
23 December 2009 (23.12.2009)
- (25) Filing Language: English
- (26) Publication Language: English
- (30) Priority Data:  
61/140,725 24 December 2008 (24.12.2008) US
- (71) Applicant (for all designated States except US): GUID-  
ED THERAPY SYSTEMS, LLC [US/US]; 33 South  
Sycamore Street, Phoenix, Arizona 85202-1105 (US).
- (72) Inventors; and
- (75) Inventors/Applicants (for US only): SLAYTON,  
Michael H. [US/US]; 1323 East Whalers Way, Tempe,  
Arizona 85283 (US). BARTHE, Peter G. [US/US];  
15002 South 30th Street, Phoenix, Arizona 85048-8716  
(US).
- (74) Agent: FRALEY, R. Lee; Snell & Wilmer L.L.P., One  
Arizona Center, 400 East Van Buren Street, Phoenix, Ari-  
zona 85004-2202 (US).

(81) Designated States (unless otherwise indicated, for every kind of national protection available): AE, AG, AL, AM, AO, AT, AU, AZ, BA, BB, BG, BH, BR, BW, BY, BZ, CA, CH, CL, CN, CO, CR, CU, CZ, DE, DK, DM, DO, DZ, EC, EE, EG, ES, FI, GB, GD, GE, GH, GM, GT, HN, HR, HU, ID, IL, IN, IS, JP, KE, KG, KM, KN, KP, KR, KZ, LA, LC, LK, LR, LS, LT, LU, LY, MA, MD, ME, MG, MK, MN, MW, MX, MY, MZ, NA, NG, NI, NO, NZ, OM, PE, PG, PH, PL, PT, RO, RS, RU, SC, SD, SE, SG, SK, SL, SM, ST, SV, SY, TJ, TM, TN, TR, TT, TZ, UA, UG, US, UZ, VC, VN, ZA, ZM, ZW.

(84) Designated States (unless otherwise indicated, for every kind of regional protection available): ARIPO (BW, GH, GM, KE, LS, MW, MZ, NA, SD, SL, SZ, TZ, UG, ZM, ZW), Eurasian (AM, AZ, BY, KG, KZ, MD, RU, TJ, TM), European (AT, BE, BG, CH, CY, CZ, DE, DK, EE, ES, FI, FR, GB, GR, HR, HU, IE, IS, IT, LT, LU, LV, MC, MK, MT, NL, NO, PL, PT, RO, SE, SI, SK, SM, TR), OAPI (BF, BJ, CF, CG, CI, CM, GA, GN, GQ, GW, ML, MR, NE, SN, TD, TG).

Published:

— without international search report and to be republished upon receipt of that report (Rule 48.2(g))

(54) Title: METHODS AND SYSTEMS FOR FAT REDUCTION AND/OR CELLULITE TREATMENT

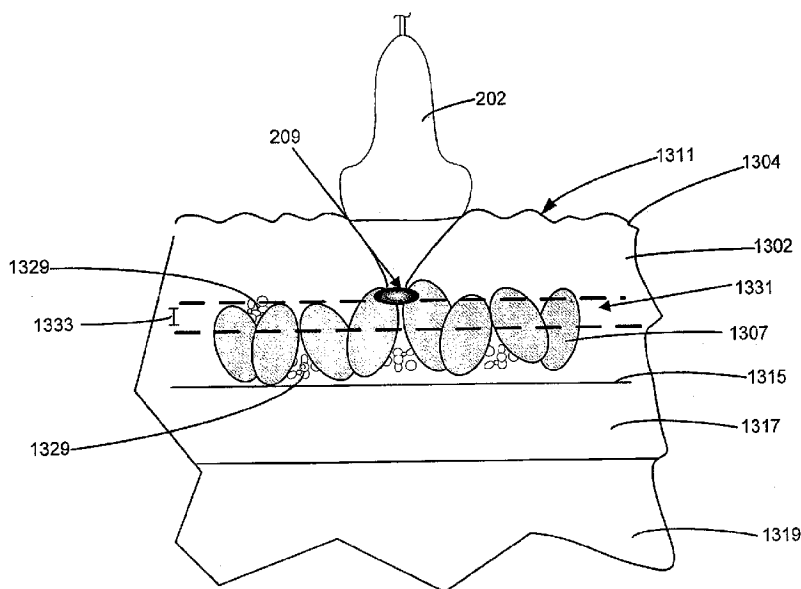

FIG. 16A

(57) Abstract: A method can include targeting a region of interest below a surface of skin, which contains fat lobuli and delivering ultrasound energy to the region of interest. The ultrasound energy generates a conformal lesion with said ultrasound energy on a surface of a fat lobuli. The lesion creates an opening in the surface of the fat lobuli, which allows the draining of a fluid out of the fat lobuli and through the opening. In addition, by applying ultrasound energy to fat cells to increase the temperature to between 43 degrees and 49 degrees, cell apoptosis can be realized, thereby resulting in reduction of fat.

WO 2010/075547 A2

## METHODS AND SYSTEMS FOR FAT REDUCTION AND/OR CELLULITE TREATMENT

### FIELD OF INVENTION

5           The present invention relates to ultrasound therapy systems, and in particular to methods and systems for treating cellulite or reducing fat.

### BACKGROUND

10           In general, cellulite refers to a common skin disorder which is characterized by a dimple appearance in a person's skin that may be found on the hips, thighs, and/or buttocks. Underneath the dermis and epidermis layers of the skin there are multiple layers of fat. Cellulite tends to develop in the subcutaneous fat layers, which is unique as compared to other fat layers because the subcutaneous fat can be structured into specific chambers surrounded by strands of linked tissue, which are known as fat lobuli. This appearance is  
15           much more common in women than in men because of differences in the way fat, muscle, and connective tissue are distributed in men's and women's skin. The lumpiness of cellulite is caused by the fat lobuli that push and distort the connective tissues beneath the skin; resulting protrusions and depressions of connective tissue anchor points create the appearance of cellulite.

20           Invasive treatments for cellulite include iontophoresis, liposuction, and electrolipophoresis, which can involve an application of a low-frequency electric current. Non-invasive treatments for cellulite can include laser and suction massage combination therapy, pneumatic pressure massage therapy, lymphatic drainage massage, and low-frequency ultrasound diathermy. Such invasive and non-invasive treatments have yielded  
25           marginal results. In addition, a number of drugs that act on fatty tissue have been tried as therapeutic agents for cellulite treatment. Such drugs can be administered orally, applied topically as ointments, or by trans-dermal injection. At this point, no drug has been reported in the scientific literature as having a significant effect on cellulite. New developments for the treatment of cellulite are needed.

30           In addition, similar techniques have attempted to address the reduction of fat in humans, but such attempts have likewise had mixed results.

**SUMMARY**

In accordance with various aspects of the present invention, non-invasive methods and systems for fat reduction and/or treatment of cellulite are provided. In accordance with an exemplary embodiment, a non-invasive method for cellulite treatment can include  
5 targeting a region of interest below a surface of skin, which contains fat lobuli and delivering ultrasound energy to the region of interest. The ultrasound energy generates a conformal lesion with said ultrasound energy on a surface of a fat lobuli. The lesion creates an opening in the surface of the fat lobuli, which allows the draining of a fluid out of the fat lobuli and through the opening.

10 In accordance with an exemplary embodiment, a non-invasive method for cellulite treatment can include targeting fat cells in a subcutaneous fat layer and delivering ultrasound energy to raise the temperature of the fat cells, stimulating apoptosis of the fat cells and then allowing the targeted fat cells to die, thereby reducing a quantity of fat cells in the subcutaneous layer.

15 Further areas of applicability will become apparent from the description provided herein. It should be understood that the description and specific examples are intended for purposes of illustration only and are not intended to limit the scope of the present invention.

**DRAWINGS**

20 The drawings described herein are for illustration purposes only and are not intended to limit the scope of the present disclosure in any way. The present invention will become more fully understood from the detailed description and the accompanying drawings wherein:

FIG. 1 illustrates a block diagram of an ultrasound treatment system for treating  
25 cellulite in accordance with exemplary embodiments of the present invention;

FIG. 2 illustrates a cross-sectional diagram of a transducer system in accordance with exemplary embodiments of the present invention;

FIGS. 3A and 3B illustrate block diagrams of an exemplary control system in accordance with exemplary embodiments of the present invention;

30 FIGS. 4A and 4B illustrate block diagrams of an exemplary probe system in accordance with exemplary embodiments of the present invention;

FIG. 5 illustrates a cross-sectional diagram of an exemplary transducer in accordance with exemplary embodiments of the present invention;

FIGS. 6A and 6B illustrate cross-sectional diagrams of an exemplary transducer in accordance with exemplary embodiments of the present invention;

FIG. 7 illustrates exemplary transducer configurations for ultrasound treatment in accordance with exemplary embodiments of the present invention;

5 FIGS. 8A and 8B illustrate cross-sectional diagrams of an exemplary transducer in accordance with exemplary embodiments of the present invention;

FIG. 9 illustrates an exemplary transducer configured as a two-dimensional array for ultrasound treatment in accordance with exemplary embodiments of the present invention;

10 FIGS. 10A-10F illustrate cross-sectional diagrams of exemplary transducers in accordance with exemplary embodiments of the present invention;

FIG. 11 illustrates a schematic diagram of an acoustic coupling and cooling system in accordance with exemplary embodiments of the present invention;

15 FIG. 12 illustrates a block diagram of a treatment system comprising an ultrasound treatment subsystem combined with additional subsystems and methods of treatment monitoring and/or treatment imaging as well as a secondary treatment subsystem in accordance with exemplary embodiments of the present invention;

FIG. 13 is a cross-sectional diagram illustrating a method of treating cellulite in accordance with exemplary embodiments of the present invention;

20 FIGS. 14A and 14B are cross-sectional diagrams illustrating another method of treating cellulite in accordance with exemplary embodiments of the present invention;

FIG. 15 is a block diagram illustrating a method of treating cellulite in accordance with exemplary embodiments of the present invention;

FIGS. 16A and 16B are cross-sectional diagrams illustrating a method of reducing fat and treating cellulite in accordance with exemplary embodiments of the present invention;

25 FIG. 17 is a block diagram illustrating a method of fat reduction in accordance with exemplary embodiments of the present invention; and

FIGS. 18A and 18B are cross-sectional diagrams illustrating a method of reducing fat in accordance with exemplary embodiments of the present invention.

### 30 DETAILED DESCRIPTION

The following description is merely exemplary in nature and is not intended to limit the present invention or its teachings, applications, or uses thereof. It should be understood that throughout the drawings, corresponding reference numerals indicate like or

corresponding parts and features. The description of specific examples indicated in various embodiments and aspects of the present invention are intended for purposes of illustration only and are not intended to limit the scope of the invention disclosed herein. Moreover, recitation of multiple embodiments having stated features is not intended to exclude other  
5 embodiments having additional features or other embodiments incorporating different combinations of the stated features.

The present invention may be described herein in terms of various functional components and processing steps. It should be appreciated that such components and steps may be realized by any number of hardware components configured to perform the specified  
10 functions. For example, the present invention may employ various medical treatment devices, visual imaging and display devices, input terminals and the like, which may carry out a variety of functions under the control of one or more control systems or other control devices. In addition, the present invention may be practiced in any number of medical or cosmetic contexts and the exemplary embodiments relating to a non-invasive methods and  
15 systems for fat reduction and/or cellulite treatment as described herein are merely indicative of exemplary applications for the invention. For example, various of the principles, features and methods discussed herein may be applied to any medical or cosmetic application, or other related applications.

Various aspects of the present invention provide a method of non-invasive treatment  
20 of cellulite. The method includes targeting a region of interest below a surface of skin, which contains fat lobuli and delivering ultrasound energy to the region of interest. The ultrasound energy generates a conformal lesion within the ultrasound energy on a surface of a fat lobuli, such as, for example, by creating a sharp focal of ultrasound energy onto the fat lobuli. The lesion creates an opening in the surface of the fat lobuli, such as, for example, by piercing  
25 the fat lobuli, which allows the draining of a fluid out of the fat lobuli through the opening.

Various aspects of the present invention can also provide a method for fat reduction that can include heating a region of interest to a temperature in a range from about 43°C to about 49°C, which can stimulate apoptosis of at least one fat cell in the fat lobuli. Still further, the method can include applying a physical treatment to said surface of skin and  
30 such physical treatment can include mesotherapy, iontophoresis, pressotherapy, pneumatic massage, lymphatic drainage, electrolipophoresis, roller massage, low frequency ultrasound, vacuum suction, laser energy, and application of RF energy. The physical treatment can be before, after, or concurrent with the delivery of the ultrasound energy. The method can

include the use of a second energy, which can be used before, after, or concurrent with the delivery of the ultrasound energy. The method can reduce the appearance of cellulite on the surface of skin.

5 Various aspects of the present invention provide a method of non-invasively stimulating apoptosis of a fat cell located in a subcutaneous fat layer. The method include targeting at least one fat cell in a subcutaneous layer below a skin surface and delivering energy to the fat cell. The delivered energy raises a temperature of the fat cell into a range from about 43°C to about 49°C, which stimulates apoptosis of the fat cell.

10 The method can further include imaging of the fat cell. Still further, the method can include generating a conformal lesion into said at least one fat cell, which can create an opening in the fat cell and allow the moving of a material out of the fat cell through the opening. The energy is typically ultrasound energy in the range of about 750 kHz to about 20 MHz or in a range from about 2MHz to about 20MHz, or other more specific ranges. Still further the method can include applying a physical treatment to said surface of skin and  
15 such physical treatment can include mesotherapy, lontophoresis, pressotherapy, pneumatic massage, lymphatic drainage, electrolipophoresis, roller massage, low-frequency ultrasound, vacuum suction, laser energy, and application of RF energy. The physical treatment can be before, after, or concurrent with the delivery of the energy. The method can include the use of a second energy, which can be used before, after, or concurrent with the delivery of the  
20 energy. The method can reduce the number of fat cells in the subcutaneous fat layer.

In addition, various aspects of the present invention provide a method that combines fat reduction and cellulite reduction. The method includes targeting a region of interest below a surface of skin, which contains fat lobuli, and delivering ultrasound energy to the region of interest. The ultrasound energy generates a conformal lesion with said ultrasound  
25 energy on a surface of a fat lobuli. The lesion creates an opening in the surface of the fat lobuli, which allows the draining of a fluid out of the fat lobuli through the opening. Additionally, the method can include targeting at least one fat cell in a subcutaneous layer below a skin surface and delivering a second energy to the fat cell. The delivered second energy raises a temperature of the fat cell into a range from about 43°C to about 49°C, which  
30 stimulates apoptosis of the fat cell.

The method can further include a physical treatment as described herein, as well as the use of a secondary energy source. The method can both reduce the number of fat cells in the subcutaneous fat layer and reduce the appearance of cellulite on a skin surface. The

method can be effective in physically breaking fat cell clusters and stretching fibrous bonds of cellulite.

In accordance with an exemplary embodiment, a method of non-invasive treatment of cellulite can include targeting a region of interest below a skin surface, which contains fat lobuli, and delivering ultrasound energy at a specified depth below the skin surface. The method further includes moving a source of the energy along the skin surface and ablating a portion of the fat lobuli at the specified depth below the skin surface.

In accordance with the exemplary method, a specified depth is generally in the range of about 1mm to about 35 mm below the skin surface. The method can include applying a physical treatment as described herein. The method can smooth the skin surface and may reduce the appearance of cellulite on the skin surface. The method can further include any of the additional method steps discussed herein.

In accordance with various aspects of the present invention, non-invasive methods and systems for the reduction of fat and/or the treating of cellulite are provided. For example, in accordance with an exemplary embodiment, with reference to Figure 1, an exemplary treatment system 100 configured to treat a region of interest 106 comprises a control system 102, an imaging/therapy probe with acoustic coupling 104, and a display system 108.

Control system 102 and display system 108 can comprise various configurations for controlling probe 104 and overall system 100 functionality. In various embodiments, control system 102 can include, for example but not limited to any of the following, a microprocessor with software and a plurality of input/output devices, systems or devices for controlling electronic and/or mechanical scanning and/or multiplexing of transducers, systems for power delivery, systems for monitoring, systems for sensing the spatial position of the probe and/or transducers, and/or systems for handling user input and recording treatment results, among others. Imaging/therapy probe 104 can comprise various probe and/or transducer configurations. For example, probe 104 can be configured for a combined dual-mode imaging/therapy transducer, coupled or co-housed imaging/therapy transducers, or simply a separate therapy probe and an imaging probe.

In accordance with an exemplary embodiment, treatment system 100 is configured for treating a deep tissue region that contains a lower part of dermis and proximal protrusions of fat lobuli into the dermis by, first, imaging region of interest ("ROI") 210 for localization of the treatment area and surrounding structures, second, delivering ultrasound

energy at a depth, distribution, timing, and energy level to achieve the desired therapeutic effect, and third monitoring the treatment area before, during, and after therapy to plan and assess the results and/or provide feedback. As to the delivery of energy, control system 102 and transducer system 102 can be suitably configured to deliver conformal ultrasound therapeutic energy to ROI 210 creating a thermal injury and coagulating the proximal protrusions of fat lobuli, thereby eliminating the fat protrusions into the dermis. As used  
5 herein, the term “dermis” refers to any part of the dermis and/or the epidermis.

Because the location and thickness of the fat lobuli varies from one patient to another (due to genetics, weight, age, etc.), imaging using a transducer can facilitate treatment within  
10 a patient, however imaging is not required to treat cellulite.

By planning a treatment protocol, the user may choose one or more spatial and/or temporal characteristics to provide conformal ultrasound energy to ROI 210. For example, the user may select one or more spatial characteristics to control, including, for example, the use of one or more transducers, one or more mechanical and/or electronic focusing  
15 mechanisms, one or more transduction elements, one or more placement locations of the transducer relative to ROI 210, one or more feedback systems, one or more mechanical arms, one or more orientations of the transducer, one or more temperatures of treatment, one or more coupling mechanisms and/or the like.

In addition, the user may choose one or more temporal characteristics to control in  
20 order to facilitate treatment of ROI 210. For example, the user may select and/or vary the treatment time, frequency, power, energy, amplitude and/or the like in order to facilitate temporal control. For more information on selecting and controlling ultrasound spatial and temporal characteristics, see U.S. Application Serial Number 11/163,148, entitled “Method and System for Controlled Thermal Injury”, filed October 6, 2005, published on June 1,  
25 2006 as U.S. Patent Application Publication No. 20060116671, and incorporated herein by reference.

After planning of a treatment protocol is complete, the treatment protocol can be implemented. That is, a transducer system can be used to deliver ultrasound energy to a treatment region to ablate select tissue in order to facilitate cellulite treatment. By delivering  
30 energy, the transducer may be driven at a select frequency, a phased array may be driven with certain temporal and/or spatial distributions, a transducer may be configured with one or more transduction elements to provide focused, defocused and/or planar energy, and/or the transducer may be configured and/or driven in any other ways hereinafter devised.

For treatment of ROI 210, transducer system 102 may be configured to deliver one or more energy fields to promote one or more effects, for example, ablation of existing tissue, the breaking up of fat cell clusters, stretching of the fibrous bonds, enhancement of lymphatic drainage, stimulation of the evacuation of fat decay products, and/or enhanced cell permeability in order to treat cellulite. Additionally, for treatment of ROI 210, transducer system 102 may be configured to deliver one or more energy fields to promote one or more effects, for example cell apoptosis, piercing cells to promote drainage, and ablating a layer of fat cells to a specified distance below a skin surface, such as for example giving the fat cells a haircut. Of course transducer system may be configured to deliver one energy field as needed by any of the methods of treatment described herein. As described herein, imaging is not necessary for treatment methods or treatment plans but rather is an optional step. For example, the dimpled pattern of cellulite is typically visible on the surface of a patient's skin and the system user can easily identify ROI 210 that will be treated.

Through operation of treatment system 100, a method for treatment of cellulite can be realized that can facilitate effective and efficient therapy without creating chronic injury to human tissue. For example, a user may first select one or more transducer probe configurations for treating ROI 210. The user may select any probe configuration described herein. Because the treatment region ranges from about 0 mm to greater than about 5.5 cm or from about 1 mm to about 3.5 cm, exemplary transducer probes may include, for example, an annular array, a variable depth transducer, a mechanically moveable transducer, a cylindrical-shaped transducer, a linear or flat transducer and the like. As used herein, the term user may include a person, employee, doctor, nurse, and/or technician, utilizing any hardware and/or software of other control systems.

Once one or more transducers are selected, the user may then image ROI 210 in order to plan a treatment protocol. By imaging ROI 210, the user may use the same treatment transducer probe and/or one or more additional transducers to image ROI 210 at a high resolution. In one embodiment, the transducer may be configured to facilitate high speed imaging over a large ROI 210 to enable accurate imaging over a large ROI 210. In another embodiment, ultrasound imaging may include, individually or in combination, the use of Doppler flow monitoring and/or color flow monitoring. In addition, other means of imaging such as photography and other visual optical methods, MRI, X-Ray, PET, infrared or others can be utilized separately or in combination for imaging and feedback of the superficial tissue and the vascular tissue in ROI 210.

An exemplary ultrasound therapy system of FIG. 1 is further illustrated in an exemplary embodiment in FIG. 2. A therapy transducer system 200 includes a transducer probe 202 connected to control system 204, and display 206, in combination may provide therapy, imaging, and/or temperature or other tissue parameters monitoring to ROI 210.

5 Exemplary transducer system 200 is configured for, first, imaging and display of ROI 210 for localization of the treatment area and surrounding structures, second, delivery of focused, unfocused, or defocused ultrasound energy at a depth, distribution, timing, and energy level to achieve the desired therapeutic effect of thermal ablation to treat cellulite, and, third, to monitor the treatment area and surrounding structures before, during, and after therapy to  
10 plan and assess the results and/or provide feedback to control system 204 and/or an operator.

Exemplary transducer probe 202 can be configured to be suitably controlled and/or operated in various manners. For example, transducer probe 202 may be configured for use within an ultrasound treatment system, an ultrasound imaging system and/or an ultrasound imaging, therapy, and/or treatment monitoring system, including motion control subsystems.

15 Control system 204 can be configured with one or more subsystems, processors, input devices, displays and/or the like. Display 206 may be configured to image and/or monitor ROI 210 and/or any particular sub-region within ROI 210. Display 206 can be configured for two-dimensional, three-dimensional, real-time, analog, digital and/or any other type of imaging. Exemplary embodiments of both control system 204 and display 206  
20 are described in greater detail herein.

ROI 210, can be comprised of superficial layer (epidermis/dermis) subcutaneous fat, lobuli, and muscle. Exemplary transducer system 200 is configured to provide cross-sectional two-dimensional imaging of the region 207, displayed as an image 205, with a controlled thermal lesion 209, confined approximately to proximal portion of fat lobuli and  
25 lower portion of dermis.

Transducer system 200 can be configured with the ability to controllably produce conformal treatment areas in superficial human tissue within ROI 210 through precise spatial and temporal control of acoustic energy deposition. In accordance with an exemplary embodiment, control system 204 and transducer probe 202 can be suitably configured for  
30 spatial control of the acoustic energy by controlling the manner of distribution of the acoustical energy. For example, spatial control may be realized through selection of the type of one or more transducer configurations insonifying ROI 210, selection of the placement and location of transducer probe 202 for delivery of acoustical energy relative to ROI 210,

e.g., transducer probe 202 configured for scanning over part or whole of ROI 210 to deliver conformal ultrasound therapeutic energy to create a thermal injury, such as a lesion, and to coagulate the proximal protrusions of fat lobuli, thereby eliminating the fat protrusions into the dermis. Transducer probe 202 may also be configured for control of other environment  
5 parameters, e.g., the temperature at the acoustic coupling interface can be controlled. In addition to the spatial control, control system 204 and/or transducer probe 202 can also be configured for temporal control, such as through adjustment and optimization of drive amplitude levels, frequency/waveform selections, and timing sequences and other energy drive characteristics to control the treatment of tissue. The spatial and/or temporal control  
10 can also be facilitated through open-loop and closed-loop feedback arrangements, such as through the monitoring of various positional and temporal characteristics. For example, through such spatial and/or temporal control, an exemplary treatment system 200 can enable the regions of thermal injury to possess arbitrary shape and size and allow the tissue to be treated in a controlled manner.

15 Transducer system 200 may be used to provide a mechanical action of ultrasound to physically break fat cell clusters and stretch the fibrous bonds. This mechanical action will also enhance lymphatic drainage, stimulating the evacuation of fat decay products. That is, the ultrasound may facilitate movement of the muscles and soft tissues within ROI 210, thereby facilitating the loosening of fat deposits and/or the break up of fibrous tissue  
20 surrounding fat deposits.

In addition, transducer system 200 can be configured to deliver various therapeutic levels of ultrasound to increase the speed at which fat metabolizes, according to Arrhenius' Law:  $K=A \cdot e^{-B/T}$ , where K is the kinetic rate of fat metabolism, A is a constant, B is the activation energy, and T is the temperature in degrees Kelvin. According to Arrhenius'  
25 Law, a metabolic reaction is a function of temperature. In exemplary embodiments, transducer system 200 is configured to provide various therapeutic levels of ultrasound to increase a temperature of fat cells in order to maximize the speed at which fat metabolizes. Moreover, transducer system 200 can be configured to deliver various therapeutic levels of ultrasound to increase the speed at which fat metabolizes. According to a modified equation  
30 of Arrhenius' Law, a metabolic reaction is a function of temperature and time, T:  $K=At \cdot e^{-B/T}$ , where K is the kinetic rate of fat metabolism, A is a constant, B is the activation energy, t is time, and T is the temperature in degrees Kelvin. In exemplary embodiments, transducer system 200 is configured to provide various therapeutic levels of ultrasound for a

specified time period or for a pulsed delivery over time to increase a temperature of fat cells in order to maximize the speed at which fat metabolizes. Moreover, transducer system 200 can be configured to deliver various therapeutic levels of ultrasound for a specified time period or for a pulsed delivery over time to increase the speed at which fat metabolizes.

5 Thus, ultrasound treatment from transducer system 200, ranging from approximately 750 kHz to 20 MHz, can increase the temperature in a treatment area, thereby increasing the metabolic reaction yield for that treatment area. As such, fat metabolism in the treatment area is increased which leads to fat cell reduction and decreases the appearance of cellulite above the treatment area. Ultrasound treatment from transducer 200 can be programmed to  
10 provide appropriate temperatures and optionally for appropriate time to ROI 210 to increase the spread of fat cell metabolism leading to fat cell destruction and optionally reducing the appearance of cellulite.

In some aspects of the present invention, a method of increasing metabolism of fat cells in a subcutaneous fat layer is provided. The method can include targeting a plurality of  
15 fat cells in a subcutaneous fat layer, heating the plurality of fat cells to a temperature as defined by Arrhenius' Law, increasing a metabolism of at least a portion of the plurality of fat cells, and reducing a portion of the plurality of fat cells. The method can also include any physical treatment described herein before, after, and/or concurrent with increasing the metabolism of the fat cells. In addition, the method can include the use a secondary energy  
20 as described herein.

As previously described, control systems 104 and 204 may be configured in a variety of manners with various subsystems and subcomponents. With reference to FIGS. 3A and 3B, in accordance with exemplary embodiments, an exemplary control system 300 can be configured for coordination and control of the entire therapeutic treatment process in  
25 accordance with the adjustable settings made by a therapeutic treatment system user. For example, control system 300 can suitably comprise power source components 302, sensing and monitoring components 304, cooling and coupling controls 306, and/or processing and control logic components 308. Control system 300 can be configured and optimized in a variety of ways with more or less subsystems and components to implement the therapeutic  
30 system for cellulite treatment, and the embodiment in FIGS. 3A and 3B are merely for illustration purposes.

For example, for power sourcing components 302, control system 300 can comprise one or more direct current (DC) power supplies 303 configured to provide electrical energy

for entire control system 300, including power required by transducer electronic amplifier/driver 312. DC current sense device 305 can also be provided to confirm the level of power going into amplifiers/drivers 312 for safety and monitoring purposes.

5 Amplifiers/drivers 312 can comprise multi-channel or single channel power amplifiers and/or drivers. In accordance with an exemplary embodiment for transducer array configurations, amplifiers/drivers 312 can also be configured with a beamformer to facilitate array focusing. An exemplary beamformer can be electrically excited by an oscillator/digitally controlled waveform synthesizer 310 with related switching logic.

10 Power sourcing components 302 can also include various filtering configurations 314. For example, switchable harmonic filters and/or matching may be used at the output of amplifier/driver 312 to increase the drive efficiency and effectiveness. Power detection components 316 may also be included to confirm appropriate operation and calibration. For example, electric power and other energy detection components 316 may be used to monitor the amount of power going to an exemplary probe system.

15 Various sensing and monitoring components 304 may also be suitably implemented within control system 300. For example, in accordance with an exemplary embodiment, monitoring, sensing and interface control components 324 may be configured to operate with various motion detection systems implemented within transducer probe 104 to receive and process information such as acoustic or other spatial and temporal information from ROI  
20 210. Sensing and monitoring components can also include various controls, interfacing and switches 309 and/or power detectors 316. Such sensing and monitoring components 304 can facilitate open-loop and/or closed-loop feedback systems within treatment system 100.

For example, in such an open-loop system, a system user can suitably monitor the imaging and/or other spatial or temporal parameters and then adjust or modify the same to  
25 accomplish a particular treatment objective. Instead of, or in combination with, open-loop feedback configurations, an exemplary treatment system can comprise a closed-loop feedback system, wherein images and/or spatial/temporal parameters can be suitably monitored within monitoring components 304 to generate signals.

30 During operation of exemplary treatment system 100, a lesion configuration of a selected size, shape, and orientation is determined. Based on that lesion configuration, one or more spatial parameters are selected, along with suitable temporal parameters, the combination of which yields the desired conformal lesion. Operation of the transducer can then be initiated to provide the conformal lesion or lesions. Open and/or closed-loop

feedback systems can also be implemented to monitor the spatial and/or temporal characteristics, and/or other tissue parameter monitoring, to further control the conformal lesions.

5 Cooling/coupling control systems 306 may be provided to remove waste heat from exemplary probe 104, provide a controlled temperature at the superficial tissue interface and deeper into tissue, and/or provide acoustic coupling from transducer probe 104 to ROI 210. Such cooling/coupling control systems 306 can also be configured to operate in both open-loop and/or closed-loop feedback arrangements with various coupling and feedback components.

10 Processing and control logic components 308 can comprise various system processors and digital control logic 307, such as one or more of microcontrollers, microprocessors, field-programmable gate arrays (FPGAs), computer boards, and associated components, including firmware and control software 326, which interfaces to user controls and interfacing circuits as well as input/output circuits and systems for communications,  
15 displays, interfacing, storage, documentation, and other useful functions. System software and firmware 326 controls all initialization, timing, level setting, monitoring, safety monitoring, and all other system functions required to accomplish user-defined treatment objectives. Further, various control switches 308 can also be suitably configured to control operation.

20 An exemplary transducer probe 104 can also be configured in various manners and can comprise a number of reusable and/or disposable components and parts in various embodiments to facilitate its operation. For example, transducer probe 104 can be configured within any type of transducer probe housing or arrangement for facilitating the coupling of a transducer to a tissue interface, with such housing comprising various shapes,  
25 contours and configurations depending on the particular treatment application. For example, in accordance with an exemplary embodiment, transducer probe 104 can be depressed against a tissue interface whereby blood perfusion is partially or wholly cut-off, and tissue is flattened in superficial treatment ROI 210. Transducer probe 104 can comprise any type of matching, such as for example, electric matching, which may be electrically switchable;  
30 multiplexer circuits and/or aperture/element selection circuits; and/or probe identification devices, to certify probe handle, electric matching, transducer usage history and calibration, such as one or more serial EEPROM (memories).

Transducer probe 104 may also comprise cables and connectors; motion mechanisms, motion sensors and encoders; thermal monitoring sensors; and/or user control and status related switches, and indicators such as LEDs. For example, a motion mechanism in probe 104 may be used to controllably create multiple lesions, or sensing of probe motion  
5 itself may be used to controllably create multiple lesions and/or stop creation of lesions, e.g. for safety reasons if probe 104 is suddenly jerked or is dropped. In addition, an external motion encoder arm may be used to hold the probe during use, whereby the spatial position and attitude of probe 104 is sent to the control system to help controllably create lesions. Furthermore, other sensing functionality such as profilometers or other imaging modalities  
10 may be integrated into the probe in accordance with various exemplary embodiments.

With reference to FIGS. 4A and 4B, in accordance with an exemplary embodiment, transducer probe 400 can comprise control interface 402, transducer 404, coupling components 406, and monitoring/sensing components 408, and/or motion mechanism 410. However, transducer probe 400 can be configured and optimized in a variety of ways with  
15 more or less parts and components to provide ultrasound energy for cellulite treatment and/or fat reduction, and the embodiments illustrated in FIGS. 4A and 4B are merely for illustration purposes. In some embodiments, transducer probe 104 is equivalent to transducer probe 400. In some embodiments, transducer probe 104, discussed above, can comprise control interface 402, transducer 404, coupling components 406, and  
20 monitoring/sensing components 408, and/or motion mechanism 410.

In accordance with an exemplary embodiment of the present invention, transducer probe 400 is configured to deliver energy over varying temporal and/or spatial distributions in order to provide energy effects and initiate responses in ROI 210. These effects can include, for example, thermal, cavitation, hydrodynamic, and resonance induced tissue  
25 effects. For example, exemplary transducer probe 400 can be operated under one or more frequency ranges to provide two or more energy effects and initiate one or more responses in ROI 210. In addition, transducer probe 400 can also be configured to deliver planar, defocused and/or focused energy to ROI 210 to provide two or more energy effects and to initiate one or more reactions. These responses can include, for example, diathermy,  
30 hemostasis, revascularization, angiogenesis, growth of interconnective tissue, tissue reformation, ablation of existing tissue, protein synthesis, cell apoptosis, and/or enhanced cell permeability.

These and various other exemplary embodiments of systems and components for such combined ultrasound treatment, effects and responses are more fully set forth in U.S. Patent Application Serial No. 10/950,112, entitled "Method and System for Combined Ultrasound Treatment", filed September 24, 2004, published on April 6, 2006 as U.S. Patent  
5 Application Publication No. 20060074355, and incorporated herein by reference.

In addition, these and various other exemplary embodiments of systems and components for such combined ultrasound treatment, effects and responses are more fully set forth in U.S. Patent No. 6,050,943, entitled "Imaging, Therapy, and Temperature Monitoring Ultrasonic System", issued April 18, 2000, and U.S Patent No. 6,500,121  
10 entitled "Imaging, Therapy, and temperature Monitoring Ultrasonic System," issued December 31, 2002, both of which are incorporated herein by reference.

Control interface 402 is configured for interfacing with control system 300 to facilitate control of transducer probe 400. Control interface components 402 can comprise multiplexer/aperture select 424, switchable electric matching networks 426, serial  
15 EEPROMs and/or other processing components and matching and probe usage information 430 and interface connectors 432.

Coupling components 406 can comprise various devices to facilitate coupling of transducer probe 400 to ROI 210. For example, coupling components 406 can comprise cooling and acoustic coupling system 420 configured for acoustic coupling of ultrasound  
20 energy and signals. Coupling system 420 with possible connections such as manifolds may be utilized to couple sound into ROI 210, control temperature at the interface and deeper into tissue, provide liquid-filled lens focusing, and/or to remove transducer waste heat. Coupling system 420 may facilitate such coupling through use of various coupling mediums, including air and other gases, water and other fluids, gels, solids, and/or any combination  
25 thereof, or any other medium that allows for signals to be transmitted between transducer active elements 412 and ROI 210. In addition to providing a coupling function, in accordance with an exemplary embodiment, coupling system 420 can also be configured for providing temperature control during the treatment application. For example, coupling system 420 can be configured for controlled cooling of an interface surface or region  
30 between transducer probe 400 and ROI 210 and beyond by suitably controlling the temperature of the coupling medium. The suitable temperature for such coupling medium can be achieved in various manners, and utilize various feedback systems, such as thermocouples, thermistors or any other device or system configured for temperature

measurement of a coupling medium. Such controlled cooling can be configured to further facilitate spatial and/or thermal energy control of transducer probe 400.

Monitoring and sensing components 408 can comprise various motion and/or position sensors 416, temperature monitoring sensors 418, user control and feedback switches 414 and other like components for facilitating control by control system 300, e.g.,  
5 to facilitate spatial and/or temporal control through open-loop and closed-loop feedback arrangements that monitor various spatial and temporal characteristics.

Motion mechanism 410 can comprise manual operation, mechanical arrangements, or some combination thereof. For example, motion mechanism 422 can be suitably  
10 controlled by control system 300, such as through the use of accelerometers, encoders or other position/orientation devices 416 to determine and enable movement and positions of transducer probe 400. Linear, rotational or variable movement can be facilitated, e.g., those depending on the treatment application and tissue contour surface.

Transducer 404 can comprise one or more transducers configured for producing  
15 conformal lesions of thermal injury in superficial human tissue within ROI 210 through precise spatial and temporal control of acoustic energy deposition. Transducer 404 can also comprise one or more transduction elements and/or lenses 412. The transduction elements can comprise a piezoelectrically active material, such as lead zirconate titanate (PZT), or any other piezoelectrically active material, such as a piezoelectric ceramic, crystal, plastic,  
20 and/or composite materials, as well as lithium niobate, lead titanate, barium titanate, and/or lead metaniobate. In addition to, or instead of, a piezoelectrically active material, transducer 404 can comprise any other materials configured for generating radiation and/or acoustical energy. Transducer 404 can also comprise one or more matching layers configured along with the transduction element such as coupled to the piezoelectrically active material.  
25 Acoustic matching layers and/or damping may be employed as necessary to achieve the desired electroacoustic response.

In accordance with an exemplary embodiment, the thickness of the transduction element of transducer 404 can be configured to be uniform. That is, transduction element 412 can be configured to have a thickness that is substantially the same throughout. In  
30 accordance with another exemplary embodiment, the thickness of transduction element 412 can also be configured to be variable. For example, transduction element(s) 412 of transducer 404 can be configured to have a first thickness selected to provide a center operating frequency of a lower range, for example from approximately 750 kHz to 5 MHz.

Transduction element 404 can also be configured with a second thickness selected to provide a center operating frequency of a higher range, for example from approximately 5 MHz to 20 MHz or more. Transducer 404 can be configured as a single broadband transducer excited with at least two or more frequencies to provide an adequate output for generating a  
5 desired response. Transducer 404 can also be configured as two or more individual transducers, wherein each transducer comprises one or more transduction element. The thickness of the transduction elements can be configured to provide center-operating frequencies in a desired treatment range. For example, transducer 404 can comprise a first transducer configured with a first transduction element having a thickness corresponding to  
10 a center frequency range of approximately 750 kHz to 5 MHz, and a second transducer configured with a second transduction element having a thickness corresponding to a center frequency of approximately 5 MHz to 20 MHz or more.

Transducer 404 may be composed of one or more individual transducers in any combination of focused, planar, or unfocused single-element, multi-element, or array  
15 transducers, including 1-D, 2-D, and annular arrays; linear, curvilinear, sector, or spherical arrays; spherically, cylindrically, and/or electronically focused, defocused, and/or lensed sources.

In accordance with another exemplary embodiment, transducer probe 400 may be suitably configured to provide three-dimensional treatment. For example, to provide three-  
20 dimensional treatment of ROI 210, with reference again to FIG. 4, a three-dimensional system can comprise transducer probe 400 configured with an adaptive algorithm, such as, for example, one utilizing three-dimensional graphic software, contained in a control system, such as for example control system 300. The adaptive algorithm is suitably configured to receive two-dimensional imaging, temperature monitoring and/or treatment information  
25 relating to ROI 210, process the received information, and then provide corresponding three-dimensional imaging, temperature and/or treatment information.

In accordance with another aspect of the invention, transducer probe 400 may be configured to provide one, two or three-dimensional treatment applications for focusing  
30 acoustic energy to one or more regions of interest. For example, as discussed above, transducer probe 400 can be suitably diced to form a one-dimensional array, e.g., a transducer comprising a single array of sub-transduction elements.

For example, with reference to an exemplary embodiment depicted in FIG. 5, exemplary transducer 500 can be configured as an acoustic array 502 to facilitate phase

focusing. That is, transducer 500 can be configured as an array of electronic apertures that may be operated by a variety of phases via variable electronic time delays. By the term "operated," the electronic apertures of transducer 500 may be manipulated, driven, used, and/or configured to produce and/or deliver an energy beam corresponding to the phase variation caused by the electronic time delay. For example, these phase variations can be used to deliver defocused beams 508, planar beams 504, and/or focused beams 506, each of which may be used in combination to achieve different physiological effects in ROI 210. Transducer 500 may additionally comprise any software and/or other hardware for generating, producing and or driving a phased aperture array with one or more electronic time delays.

Transducer 500 can also be configured to provide focused treatment to one or more regions of interest using various frequencies. In order to provide focused treatment, transducer 500 can be configured with one or more variable depth devices to facilitate treatment. For example, transducer 500 may be configured with variable depth devices disclosed in commonly assigned U.S. Patent Application 10/944,500, entitled "System and Method for Variable Depth Ultrasound", filed on September 16, 2004, published on March 16, 2006, as U.S. Patent Application Publication No. 20060058664, and incorporated herein by reference. In some embodiments, transducer probe 104 or transducer probe 400 can comprise transducer 500.

In addition, transducer 500 can also be configured to treat one or more additional ROI 210 through the enabling of sub-harmonics or pulse-echo imaging, as disclosed in commonly assigned U.S. Patent Application 10/944,499, entitled "Method and System for Ultrasound Treatment with a Multi-directional Transducer", filed on September 16, 2004, published on March 16, 2006 as U.S. Patent Application Publication No. 20060058707, and incorporated herein by reference.

Moreover, any variety of mechanical lenses or variable focus lenses, e.g. liquid-filled lenses, may also be used to focus and/or defocus the sound field. For example, with reference to exemplary embodiments depicted in FIGS. 6A and 6B, transducer 600 may also be configured with an electronic focusing array 604 in combination with one or more transduction elements 606 to facilitate increased flexibility in treating ROI 210. Array 604 may be configured in a manner similar to transducer 502. That is, array 604 can be configured as an array of electronic apertures that may be operated by a variety of phases via variable electronic time delays, for example,  $T_1, T_2...T_j$ . By the term "operated," the

electronic apertures of array 604 may be manipulated, driven, used, and/or configured to produce and/or deliver energy in a manner corresponding to the phase variation caused by the electronic time delay. For example, these phase variations can be used to deliver defocused beams, planar beams, and/or focused beams, each of which may be used in combination to achieve different physiological effects in ROI 210.

Transduction elements 606 may be configured to be concave, convex, and/or planar. For example, in an exemplary embodiment depicted in Fig. 6A, transduction elements 606 are configured to be concave in order to provide focused energy for treatment of ROI 210. Additional embodiments of transducer 600 are disclosed in U.S. Patent Applications and U.S. Patents that have been incorporated by reference herein.

In another exemplary embodiment, depicted in FIG. 6B, transduction elements 606 can be configured to be substantially flat in order to provide substantially uniform energy to ROI 210. While FIGS. 6A and 6B depict exemplary embodiments with transduction elements 604 configured as concave and substantially flat, respectively, transduction elements 604 can be configured to be concave, convex, and/or substantially flat. In addition, transduction elements 604 can be configured to be any combination of concave, convex, and/or substantially flat structures. For example, a first transduction element can be configured to be concave, while a second transduction element can be configured to be substantially flat. In some embodiments, transducer probe 104 or transducer probe 400 can comprise transducer 600.

To further illustrate the various structures for transducer 404, with reference to FIG. 7, ultrasound therapy transducer 700 can be configured for a single focus, an array of foci, a locus of foci, a line focus, and/or diffraction patterns. Transducer 700 can also comprise single elements, multiple elements, annular arrays, one-, two-, or three-dimensional arrays, broadband transducers, and/or combinations thereof, with or without lenses, acoustic components, and mechanical and/or electronic focusing. Transducers configured as spherically focused single elements 702, annular arrays 704, annular arrays with damped regions 706, line focused single elements 708, 1-D linear arrays 710, 1-D curvilinear arrays in concave or convex form, with or without elevation focusing, 2-D arrays, and 3-D spatial arrangements of transducers may be used to perform therapy and/or imaging and acoustic monitoring functions. For any transducer configuration, for example but not limited to including those employed in transducer probe 104 or transducer probe 400, focusing and/or defocusing may be in one plane or two planes via mechanical focus 720, convex lens 722,

concave lens 724, compound or multiple lenses 726, planar form 728, or stepped form, such as illustrated in FIG. 10F. Any transducer or combination of transducers may be utilized for treatment. For example, an annular transducer may be used with an outer portion dedicated to therapy and the inner disk dedicated to broadband imaging wherein such imaging  
5 transducer and therapy transducer have different acoustic lenses and design, such as illustrated in FIGS. 10C-10F, as described below.

With reference to FIGS. 8A and 8B, transducer 404 can be configured as single-element arrays, wherein a single-element 802, e.g., a transduction element of various structures and materials, can be configured with a plurality of masks 804, such masks  
10 comprising ceramic, metal or any other material or structure for masking or altering energy distribution from element 802, creating an array of energy distributions 808. Masks 804 can be coupled directly to element 802 or separated by a standoff 806, such as any suitably solid or liquid material.

In accordance with another exemplary embodiment, transducer probe 104 or  
15 transducer probe 400 may be suitably diced in two dimensions to form a two-dimensional array. For example, with reference to FIG. 9, an exemplary two-dimensional array 900 can be suitably diced into a plurality of two-dimensional portions 902. Two-dimensional portions 902 can be suitably configured to focus on the treatment region at a certain depth, and thus provide respective slices 904, 907 of the treatment region. As a result, the two-  
20 dimensional array 900 can provide a two-dimensional slicing of image planes of a treatment region, thus providing two-dimensional treatment.

In accordance with another exemplary embodiment, transducer probe 400 may be suitably configured to provide three-dimensional treatment. For example, to provide three-dimensional treatment of ROI 210, with reference again to FIG. 3, a three-dimensional  
25 system can comprise transducer probe 104 or transducer probe 400 configured with an adaptive algorithm, such as, for example, one utilizing three-dimensional graphic software, contained in a control system, such as for example control system 300. The adaptive algorithm is suitably configured to receive two-dimensional imaging, temperature and/or treatment information relating to ROI 210, process the received information, and then  
30 provide corresponding three-dimensional imaging, temperature and/or treatment information.

In accordance with an exemplary embodiment, with reference again to FIG. 9, an exemplary three-dimensional system can comprise a two-dimensional array 900 configured

with an adaptive algorithm to suitably receive 904 slices from different image planes of the treatment region, process the received information, and then provide volumetric information 906, e.g., three-dimensional imaging, temperature and/or treatment information. Moreover, after processing the received information with the adaptive algorithm, the two-dimensional array 900 may suitably provide therapeutic heating to the volumetric region 906 as desired.

Alternatively, rather than utilizing an adaptive algorithm, such as three-dimensional software, to provide three-dimensional imaging and/or temperature information, an exemplary three-dimensional system can comprise a single transducer 404 configured within a probe arrangement to operate from various rotational and/or translational positions relative to a target region.

An exemplary transducer 404 can also be configured as an annular array to provide planar, focused and/or defocused acoustical energy. For example, with reference to FIGS. 10A and 10B, in accordance with an exemplary embodiment, an annular array 1000 can comprise a plurality of rings 1012, 1014, 1016 to N. Rings 1012, 1014, 1016 to N can be mechanically and electrically isolated into a set of individual elements, and can create planar, focused, or defocused waves. For example, such waves can be centered on-axis, such as by methods of adjusting corresponding transmit and/or receive delays,  $\tau_1$ ,  $\tau_2$ ,  $\tau_3$  ...  $\tau_N$ . An electronic focus can be suitably moved along various depth positions, and can enable variable strength or beam tightness, while an electronic defocus can have varying amounts of defocusing. In accordance with an exemplary embodiment, a lens and/or convex or concave shaped annular array 1000 can also be provided to aid focusing or defocusing such that at any time differential delays can be reduced. Movement of annular array 1000 in one, two or three-dimensions, or along any path, such as through use of probes and/or any conventional robotic arm mechanisms, may be implemented to scan and/or treat a volume or any corresponding space within ROI 210.

Transducer 404 can also be configured in other annular or non-array configurations for imaging/therapy functions. For example, with reference to FIGS. 10C-10F, a transducer can comprise an imaging element 1012 configured with therapy element(s) 1014. Elements 1012 and 1014 can comprise a single-transduction element, e.g., a combined imaging/transducer element, or separate elements, can be electrically isolated 1022 within the same transduction element or between separate imaging and therapy elements, and/or can comprise standoff 1024 or other matching layers, or any combination thereof. For example, with particular reference to Fig. 10F, a transducer can comprise an imaging

element 1012 having a surface 1028 configured for focusing, defocusing or planar energy distribution, with therapy elements 1014 including a stepped-configuration lens configured for focusing, defocusing, or planar energy distribution.

5 Various shaped treatment lesions can be produced using the various acoustic lenses and designs in FIGS. 10A-10F. For example, mushroom-shaped lesions may be produced from a spherically-focused source, and/or planar lesions from a flat source. That is, as the application of ablative ultrasound energy continues, this causes thermal expansion to generate a growing lesion. Concave planar sources and arrays can produce a “V-shaped” or ellipsoidal lesion. Electronic arrays, such as a linear array, can produce defocused, planar, 10 or focused acoustic beams that may be employed to form a wide variety of additional lesion shapes at various depths. An array may be employed alone or in conjunction with one or more planar or focused transducers. Such transducers and arrays in combination produce a very wide range of acoustic fields and their associated benefits. A fixed focus and/or variable focus lens or lenses may be used to further increase treatment flexibility. A convex- 15 shaped lens, with acoustic velocity less than that of superficial tissue, may be utilized, such as a liquid-filled lens, gel-filled or solid gel lens, rubber or composite lens, with adequate power handling capacity; or a concave-shaped, low profile, lens may be utilized and composed of any material or composite with velocity greater than that of tissue. While the structure of transducer source and configuration can facilitate a particular shaped lesion as suggested above, such structures are not limited to those particular shapes as the other spatial 20 parameters, as well as the temporal parameters, can facilitate additional shapes within any transducer structure and source.

In accordance with an exemplary embodiment, with additional reference to FIG. 11, acoustic coupling and cooling 1140 can be provided to acoustically couple energy and 25 imaging signals from transducer probe 1104 to and from ROI 210, to provide thermal control at the probe to ROI 210 interface 1110, and to remove potential waste heat from the transducer probe at region 1144. Temperature monitoring can be provided at the coupling interface via thermal sensor 1146 to provide a mechanism of temperature measurement 1148 and control via control system 1106 and thermal control system 1142. Thermal control may 30 consist of passive cooling such as via heat sinks or natural conduction and convection or via active cooling such as with peltier thermoelectric coolers, refrigerants, or fluid-based systems comprised of pump, fluid reservoir, bubble detection, flow sensor, flow

channels/tubing 1144 and thermal control 1142. In some embodiments, transducer probe 1104 can be equivalent to transducer probe 104 or transducer probe 400.

In accordance with another exemplary embodiment, with reference to FIG. 12, an exemplary treatment system 200 can be configured with and/or combined with various auxiliary systems to provide additional functions. For example, an exemplary treatment system 1200 for treating ROI 210 can comprise a control system 1206, a probe 1204, and a display 1208. In some embodiments, probe 1204 can be equivalent to transducer probe 104 or transducer probe 400 or transducer probe 1104. Treatment system 1200 further comprises an auxiliary imaging modality 1274 and/or auxiliary monitoring modality 1272 may be based upon at least one of photography and other visual optical methods, magnetic resonance imaging (MRI), computed tomography (CT), optical coherence tomography (OCT), electromagnetic, microwave, or radio frequency (RF) methods, positron emission tomography (PET), infrared, ultrasound, acoustic, or any other suitable method of visualization, localization, or monitoring of cellulite within ROI 210, including imaging/monitoring enhancements. Such imaging/monitoring enhancement for ultrasound imaging via probe 1204 and control system 1206 could comprise M-mode, persistence, filtering, color, Doppler, and harmonic imaging among others; furthermore an ultrasound treatment system 1270, as a primary source of treatment, may be combined with a secondary source of treatment 1276, including radio frequency (RF), intense pulsed light (IPL), laser, infrared laser, microwave, or any other suitable energy source.

An ultrasound treatment system as described herein, as a primary source of treatment, may be combined with a secondary source of treatment configured to deliver secondary treatment energy. Secondary treatment energy includes, but is not limited to, radio frequency (RF) energy, microwave energy, infrared light, visible light, ultraviolet light, and any other suitable electromagnetic energy. Secondary treatment energy may be coherent (as in a laser), incoherent, scattered, pulsed, refracted, focused, defocused, and/or delivered in any other form suitable for achieving a bio-effect.

In an exemplary embodiment, ultrasound treatment is combined with blue light treatment. As used herein, "blue light" means electromagnetic energy having a wavelength from about 400 nanometers to about 440 nanometers. Blue light is applied to the skin. Blue light may be applied as a pretreatment before therapeutic ultrasound energy is applied. Blue light may also be applied concurrently with therapeutic ultrasound energy. Furthermore, blue

light may be applied before, during, or after therapeutic ultrasound treatment, or during any combination thereof.

In accordance with an exemplary embodiment, blue light is applied to ROI 210 for a period between 5 seconds and 20 minutes. Blue light may be applied to ROI 210 for any  
5 suitable amount of time in order to achieve a desired bio-effect.

In another exemplary embodiment, ultrasound treatment is combined with red light treatment. As used herein, "red light" means electromagnetic energy having a wavelength from about 600 nanometers to about 1350 nanometers. Red light is applied to ROI 210. Red light may be applied as a pretreatment before therapeutic ultrasound energy is applied. Red  
10 light may also be applied concurrently with therapeutic ultrasound energy. Furthermore, red light may be applied before, during, or after therapeutic ultrasound treatment, or during any combination thereof.

In accordance with an exemplary embodiment, red light is applied to the skin for a period between 5 seconds and 20 minutes. Red light may be applied to the skin for any  
15 suitable amount of time in order to achieve a desired bio-effect.

In accordance with an exemplary embodiment, secondary treatment energy can be delivered by the probe which contains an ultrasound energy source. In other exemplary embodiments, secondary treatment energy is delivered by a source external to the probe. Secondary treatment energy may be generated by a light emitting diode (LED), a laser, an  
20 incandescent bulb, a fluorescent tube, an antenna, an intense pulsed light source, or any other suitable electromagnetic energy generation mechanism.

In one exemplary embodiment, energy is delivered in relatively small ablative areas in order to minimize and/or prevent scar tissue from forming. That is, each ablative area of treatment can range from approximately 100 microns to 55 mm in diameter. In another  
25 exemplary embodiment, ultrasound energy is used in a "lawnmower" type fashion to evenly ablate a treatment region to provide a substantially planar surface of lobuli. This "lawnmower"-type ablation in turn, helps to achieve a substantially smooth surface of the epidermis.

With reference to FIG. 13, another method of non-invasive treatment of cellulite is  
30 illustrated according to various other embodiments of the present invention. The cross-sectional diagram illustrates the layers of tissue below skin surface 1304 which is not to scale and is used for illustration purposes. Dermis layer 1302 includes skin surface 1304 and both the epidermis and dermis portions of the skin. Below the dermis layer 1302 is fat

lobuli 1307. Fat lobuli 1307 causes protusions in skin surface 1304, which gives skin surface 1304 a dimpled appearance 1311 or cellulite. Below fat lobuli 1307 is facia layer 1315, subcutaneous fat layer 1317 and then muscle layer 1319.

In various aspects, probe 202 is coupled to skin surface 1304 and emits ultrasound  
5 energy to create conformal lesion 209 at specific depth 1305. Conformal lesion 209 ablates a portion of fat lobuli 1307. Probe movement 1303 along skin surface 1304 allows for ablation of a plurality of fat lobuli 1307 at specific depth 1305. This may be described as a lawnmower type ablation or a haircut of fat lobuli 1307. Probe movement 1303 leaves behind smoothed skin 1309. The treatment may need to be repeated in order to achieve a desired  
10 degree of smoothed skin 1309. This method may be combined with any other method steps described herein such as for example applying a physical treatment or applying a secondary energy source.

In accordance with an exemplary embodiment of the present invention, a method of non-invasive treatment of cellulite includes targeting ROI 210 below skin surface 1304,  
15 which contains fat lobuli 1307, and delivering ultrasound energy at specified depth 1305 below skin surface 1304. The method further includes moving a source of the energy along skin surface 1304 and ablating a portion of fat lobuli 1307 at specified depth 1305 below skin surface 1304.

Specified depth 1305 is generally in the range of about 1mm to about 35 mm below  
20 skin surface 1304. The method can include applying a physical treatment as described herein. The method can smooth skin surface 1304 and may reduce the appearance of cellulite on skin surface 1304. The method can further include any of the additional method steps discussed herein.

With reference to FIG. 14, a method of non-invasive treatment of cellulite is  
25 illustrated according to another exemplary embodiment of the present invention. The cross-sectional diagram illustrates the layers of tissue below skin surface 1304 which is not to scale and is used for illustration purposes. Dermis layer 1302 includes skin surface 1304 and both the epidermis and dermis portions of the skin. Below dermis layer 1302 is fat lobuli 1307. Fat lobuli 1307 causes protusions in skin surface 1304, which gives skin  
30 surface 1304 a dimpled appearance 1311 or cellulite. Below fat lobuli 1307 is facia layer 1315, subcutaneous fat layer 1317 and then muscle layer 1319.

In the exemplary embodiment illustrated in FIG. 14A, probe 202 is coupled to skin surface 1304 and emits ultrasound energy to create conformal lesion 209 in the surface of fat

lobuli 1307 to create opening 1321. A material that is housed in the punctured fat lobuli 1317 flows out of opening 1321. This material can be a fluid, a lipid, a lymphatic substance, fat, tissue, bodily materials, or any other material and mixtures thereof. The material can be any tissue, fluid, or the like that is typically housed in fat lobuli 1317.

5 Moving to FIG. 14B, reduced fat lobuli 1325 has shriveled due to the loss of the material. The shrinking of reduced fat lobuli 1325 can cause smoothed skin 1309 above reduced fat lobuli 1325 which has been drained of the material, thereby reducing the appearance of cellulite on skin surface 1304.

10 In accordance with another exemplary embodiment, a method of non-invasive treatment of cellulite includes targeting ROI 210 below skin surface 1304, which contains fat lobuli 1307 and delivering ultrasound energy to ROI 210. The ultrasound energy generates conformal lesion 209 with the ultrasound energy on a surface of fat lobuli 1307. The lesion creates opening 1321 in the surface of fat lobuli 1307, which allows the draining of a fluid out of fat lobuli 1307 and through opening 1321.

15 The method can further include heating ROI 210 to a temperature in a range from about 43°C to about 49°C, which can stimulate apoptosis of at least one fat cell in fat lobuli 1307. Still further the method can include applying a physical treatment to skin surface 1304 and such physical treatment can include mesotherapy, iontophoresis, pressotherapy, pneumatic massage, lymphatic drainage, electrolipophoresis, roller massage, low frequency  
20 ultrasound, vacuum suction, laser energy, and/or an application of RF energy. The physical treatment can be before, after, or concurrent with the delivery of the ultrasound energy. The method can include the use of a second energy, which can be used before, after, or concurrent with the delivery of the ultrasound energy. The method can reduce the appearance of cellulite on skin surface 1304.

25 With additional reference to FIG. 15, a block diagram illustrates an exemplary method for non-invasive treatment of cellulite according to various embodiments of the present invention. For example, method 1500 is a non-invasive treatment of cellulite. In step 1502, fat lobuli 1307 is targeted. Imaging the fat lobuli in a step 1503 may be useful in the targeting of fat lobuli 1307 but is optional or otherwise not required.

30 Targeting step 1502 is followed by energy delivery step 1504 which delivers ultrasound energy to form a conformal lesion 209 in the target which can be for example fat lobuli 1307. The ultrasound energy can be in the range from about 750 kHz to about 20 MHz and may be more useful in the range from about 2 MHz to about 10 MHz. The power

of the ultrasound energy may be in a range from about 1 W to about 50 W and may be more useful in the range from about 2 W to about 20 W. The duration of the ultrasound energy may be in the range from about 10 milliseconds to about 20 minutes, or even more if desired. Energy delivery step 1504 may include applying secondary energy step 1505, 5 which is optional. Applying a secondary energy step 1505 may be useful in heating the tissue around the target to an elevated temperature prior to or during delivery of ultrasound energy to the targeted region, and can comprise a variety of energy sources including those discussed previously herein.

Energy delivery step 1504 is followed by creating an opening in the target step 1506, 10 which provides an opening 1321. In this step 1506, conformal lesion 209 creates opening 1321 in the target. Upon creating an opening in the target, step 1506 is followed by a release of contents step 1508, in which at least a portion of the contents of fat lobuli 1307 are released through opening 1321, e.g., by draining. An application of secondary energy step 1505 may be applied after the creation of opening 1321 but is optional. Such application of 15 secondary energy step 1505 may be useful in smoothing skin surface 1304 and/or in facilitating movement of at least a portion of the contents of fat lobuli 1307 to facilitate their release. The contents of fat lobuli 1307 can be a fluid, a lipid, a lymphatic substance, fat, tissue, bodily materials, or any other material and mixtures thereof. An application of physical treatment step 1507, such as, for example, by applying physical pressure or force to 20 facilitate movement, may be useful in facilitating the releasing of at least a portion of the contents of fat lobuli 1307 through opening 1321, but this step 1507 is optional. An optional imaging step 1509 can be added for reviewing if the treatment was successful. If the treatment complete decision 1511 is yes, then the result is the final step 1510 wherein the skin is smoothed. If the treatment complete decision 1511 is no, then move to step 1504 for 25 further treatment of the target until the treatment is successful within the treatment area, resulting in the smoothing of skin step 1510 which reduces the appearance of cellulite on skin surface 1304.

In accordance with another exemplary embodiment, a method of non-invasive treatment of cellulite includes identifying fat lobuli 1307 and creating a sharp focal of 30 ultrasound energy onto fat lobuli 1307. The focal of energy pierces fat lobuli 1307 to create opening 1321, which then allows the flowing of a material out of fat lobuli 1307 through opening 1321. The method can further include any of the additional method steps discussed herein.

Now referring to FIG. 16, a method of non-invasive treatment for a reduction of fat is illustrated according to another exemplary embodiment of the present invention. In various embodiments, this method can be used as a non-invasive treatment of cellulite. The cross-sectional diagram illustrates the layers of tissue below skin surface 1304 which is not to scale and is used for illustration purposes. Dermis layer 1302 includes skin surface 1304 and both the epidermis and dermis portions of the skin. Below dermis layer 1302 is fat lobuli 1307. Fat lobuli 1307 causes protrusions in skin surface 1304, which gives skin surface 1304 a dimpled appearance 1311 or cellulite. Below fat lobuli 1307 is facia layer 1315, subcutaneous fat layer 1317 and then muscle layer 1319.

10 In an exemplary embodiment, as illustrated in FIG. 16A, probe 202 is coupled to skin surface 1304 and emits ultrasound energy into adipose target area 1331. Adipose target area 1331 can include a portion of fat lobuli 1307. Adipose target area 1331 can include ROI 210. Fat lobuli 1307 can contain a plurality of adipose cells and a portion of the plurality of adipose cells can be located in adipose target area 1331. Adipose target area 1331 can include a plurality of other adipose cells 1329 that may be amongst fat lobuli 1307.

Probe 202 is targeted to deliver energy in adipose target area 1331. Adipose target area 1331 can be from about 1 mm to about 100 mm or greater below skin surface 1304. Height 1333 of adipose target area 1331 can be from about 1 mm to about 10 mm or greater. Probe 202 delivers energy to create at least one conformal lesion 209 in adipose target area 1331. Delivered energy raises a temperature of at least a portion of adipose cells in fat lobuli 1307 and/or other adipose cells 1329 located in adipose target area 1331 to a range from about 43°C to about 49°C, which stimulates apoptosis of fat cells, which can include at least a portion of other adipose cells in fat lobuli 1307 and/or other adipose cells 1329.

As illustrated in FIG. 16B, over a period of time, the portion of the plurality of adipose cells fat lobuli 1307 that were located in adipose target zone 1331 begin cell apoptosis. As these adipose cells die, fat lobuli 1307 shrinks. This cell apoptosis of the adipose cells reduces the amount of fat in an area on a patient. The effect of the reduction in size of fat lobuli 1307 by the adipose cell apoptosis can create smoothed skin 1309. In addition, other adipose cells 1329 that were located in adipose target area 1331 can begin cell apoptosis. As these other adipose cells 1329 die, skin surface 1304 can relax, which can contribute to creating smoothed skin 1309. Probe 202 can be moved along skin surface 1304 to enlarge the treatment of adipose target area 1331 of a patient's body.

An exemplary method, such as that illustrated by FIG. 16, can include applying a physical treatment to skin surface 1304, and such physical treatment can include mesotherapy, iontophoresis, pressotherapy, pneumatic massage, lymphatic drainage, electrolipophoresis, roller massage, low frequency ultrasound, vacuum suction, laser energy, and application of RF energy. The physical treatment can be before, after, or concurrent with the delivery of the energy. The method can include the use of a second energy, which can be used before, after, or concurrent with the delivery of the energy.

With reference to FIG. 17, a block diagram illustrates a method 1600 of fat reduction according to an exemplary embodiment. For example, the method 1600 begins with step 1602 which is the targeting of a group of fat cells in adipose target area 1331. This targeting step 1602 may include the movement of probe 202 to include an enlarged target area. In targeting step 1602 a depth below skin surface 1304 that is appropriate for adipose target area 1331 is determined. Generally, a depth of greater than 1 mm but less than 100 mm is appropriate and this can vary from patient to patient depending on location on the body and level of patient's body fat.

Targeting step 1602 is followed by energy delivery step 1603 which is the delivering of ultrasound energy to the target fat cells. The ultrasound energy can be in the range from about 750 kHz to about 20 MHz and may be more useful in the range from about 2 MHz to about 10 MHz. The power of the ultrasound energy may be in a range from about 1 W to about 50 W and may be more useful in the range from about 2 W to about 20 W. The duration of the ultrasound energy may be in the range from about 10 milliseconds to about 20 minutes, or more if desired.

Energy delivery step 1603 is followed by raising temperature step 1604, which is the raising of the fat cell temperature from about 43.5°C to about 49°C. Different combinations of parameters outlined in energy delivery step 1603 can be useful to raise the fat cell temperature to the desired range in step 1604. Raising temperature step 1604 creates or facilitates the stimulating apoptosis step 1605 which is the stimulating cell apoptosis of the fat cells in adipose target area 1331. If the fat cells are held in the desired temperature range for a sufficient amount of time, cell apoptosis will occur. Stimulating apoptosis step 1605 is followed by step 1606 which is the allowing of the targeted fat cells and/or targeted portions thereof to die. Upon allowing target portions to die in step 1606 results, a reduction of the total number of fat cells in adipose target area 1331 is achieved 1607. This reduction of the total number of fat cells can result in lowering the circumference of a patient's body, for

example the circumference of thighs, buttocks, hips, waist, and the like. In addition, this reduction of adipose target area 1331 can reduce an appearance of cellulite on skin surface 1304. Alternatively, or simultaneously, method 1600 can target fat cells in the subcutaneous fat layers to provide similar results.

5           Now with reference to FIGs. 18A and 18B, a method of non-invasive treatment for a reduction of fat is illustrated according to various exemplary embodiments of the present invention. In various embodiments, this method can be used as a non-invasive treatment of subcutaneous fat layer 1317. The cross-sectional diagram illustrates the layers of tissue below skin surface 1304 which is not to scale and is used for illustration purposes. The  
10       dermis layer 1302 includes skin surface 1304 and both the epidermis and dermis portions of the skin. Below dermis layer 1302 is fat lobuli 1307. Fat lobuli 1307 causes protrusions in skin surface 1304, which gives skin surface 1304 a dimpled appearance 1311 or cellulite. Below fat lobuli 1307 is fascia layer 1315, subcutaneous fat layer 1317 and then muscle layer 1319. Subcutaneous fat layer 1317 can have a selected depth 1337.

15           In an exemplary embodiment as illustrated in FIG. 18A, probe 202 is coupled to skin surface 1304 and emits ultrasound energy into adipose target area 1331. Adipose target area 1331 can include a portion of subcutaneous fat layer 1317. Subcutaneous fat layer 1317 can contain a plurality of adipose cells and a portion of the plurality of adipose cells can be located in adipose target area 1331.

20           Probe 202 is targeted to deliver energy in adipose target area 1331. Adipose target area 1331 can be from about 1 mm to about 100 mm or greater below the surface of the skin 1304. Height 1333 of adipose target area 1331 can be from about 1 mm to about 10 mm or greater. Probe 202 delivers energy to create at least one conformal lesion 209 which is located in adipose target area 1331. Delivered energy raises a temperature of at least a  
25       portion of the adipose cells located in adipose target area 1331 in to a range from about 43°C to about 49°C, which stimulates apoptosis of the fat cells, which can include at least a portion of adipose cells in fat lobuli 1307 and/or other adipose cells 1399.

30           Over a period of time, the portion of the plurality of adipose cells in subcutaneous fat layer 1317 that were located in adipose target area 1331 begin cell apoptosis. As these adipose cells die, subcutaneous fat layer 1317 shrinks. This cell apoptosis of the adipose cells reduces the amount of fat in an area on a patient. As illustrated in FIG. 18B, the effect of the adipose cell apoptosis in subcutaneous fat layer 1317 can create smoothed skin 1309.

In addition, the effect of the adipose cell apoptosis in subcutaneous fat layer 1317 can create a reduction 1335 in the total volume of tissue in the treatment area. In accordance with the method, probe 202 can be moved along skin surface 1304 to enlarge the treatment of adipose target area 1331 of a patient's body. For example, this reduction 1335 can cause a decrease in the circumference of a patient's thighs, buttocks, hips, waist, and the like. As the adipose cell apoptosis in subcutaneous fat layer 1317 continues, skin surface 1304 can relax and can contribute to creating smoothed skin 1309. Subcutaneous fat layer 1317 can have a reduced depth 1339 after cell apoptosis. Reduced cell depth 1339 generally results from thickness of depth 1337 less the thickness 1333 of adipose target area 1331, i.e., the portion shrunk from cell apoptosis.

Various exemplary methods as illustrated in FIG.18 provide a method of non-invasively stimulating apoptosis of a fat cell located in subcutaneous fat layer 1317. The method includes targeting at least one fat cell in subcutaneous fat layer 1317 below skin surface 1304 and delivering energy to the fat cell. The delivered energy raises a temperature of the fat cell into a range from about 43°C to about 49°C, which stimulates apoptosis of the fat cell.

The method can further include imaging of a fat cell or fat lobuli 1307. Still further, the method can include generating conformal lesion 209 into at least one fat cell, which can create opening 1321 in a fat cell or fat lobuli 1307 and allow the moving of a material out of a fat cell or fat lobuli 1307 and through opening 1321. This material can be a fluid, a lipid, a lymphatic substance, fat, tissue, bodily materials, or any other material and mixtures thereof. The ultrasound energy can be in the range from about 750 kHz to about 20 MHz and may be more useful in the range from about 2 MHz to about 10 MHz. The power of the ultrasound energy may be in a range from about 1 W to about 50 W and may be more useful in the range from about 2 W to about 20 W. The duration of the ultrasound energy may be in the range from about 10 milliseconds to about 20 minutes. Still further, the method can include applying a physical treatment to skin surface 1304 and such physical treatment can include mesotherapy, iontophoresis, pressotherapy, pneumatic massage, lymphatic drainage, electrolipophoresis, roller massage, low frequency ultrasound, vacuum suction, laser energy, and application of RF energy. The physical treatment can be before, after, or concurrent with the delivery of the energy. The method can include the use of a second energy, which can be used before, after, or concurrent with the delivery of the energy. The method can reduce the number of fat cells in subcutaneous fat layer 1317.

In addition, various other exemplary embodiments of the present invention can include a method that combines fat reduction and cellulite reduction. The method includes targeting ROI 210 below skin surface 1304, which contains fat lobuli 1307 and delivering ultrasound energy to ROI 210. The ultrasound energy generates conformal lesion 209 with  
5 said ultrasound energy on a surface of fat lobuli 1307. Conformal lesion 209 creates opening 1321 in the surface of fat lobuli 1307, which allows the draining of a fluid out of fat lobuli 1307 and through opening 1321. Additionally, the method can include targeting at least one fat cell in subcutaneous fat layer 1321 below skin surface 1304 and delivering a second energy to the fat cell. The delivered second energy raises a temperature of the fat  
10 cell into a range from about 43°C to about 49°C, which stimulates apoptosis of the fat cell.

The method can further include a physical treatment as described herein, as well as the use of a secondary energy source. The method can both reduce the number of fat cells in subcutaneous fat layer 1317 and reduce the appearance of cellulite on skin surface 1304. The method can be effective in the physically breaking fat cell clusters and stretching  
15 fibrous bonds of cellulite.

In accordance with another exemplary embodiment of the present invention, a method of non-invasive treatment of cellulite includes identifying fat lobuli 1307 and creating a sharp focal of ultrasound energy onto fat lobuli 1307. The focal of energy pierces fat lobuli 1307 to create opening 1321, which then allows the flowing of a material out of fat  
20 lobuli 1307 through opening 1321. The method can further include any of the additional method steps discussed herein.

In various embodiments, the energy is delivered at a treatment depth from about 0 mm to about 50 mm or about 1 mm to about 35 mm. The ultrasound energy can be in the range from about 750 kHz to about 20 MHz and may be more useful in the range from about  
25 2 MHz to about 10 MHz. The power of the ultrasound energy may be in a range from about 1 W to about 50 W and may be more useful in the range from about 2 W to about 20 W. The duration of the ultrasound energy may be in the range from about 10 milliseconds to about 20 minutes.

Once the treatment protocol, for any of the methods of treatment discussed herein or  
30 variations thereof, has been implemented, ROI 210 may have one or more reactions to the treatment. For example, in some embodiments, the tissue responds by enhancement of lymphatic drainage, evacuation of fat decay products, creation of a thermal injury and/or coagulation of proximal protrusions of fat lobuli 1307.

In an exemplary embodiment, energy such as ultrasound energy is emitted from a treatment system at multiple depths to target numerous areas within a specific ROI 210. Multiple layers of tissue within ROI 210 are treated from the surface down to the deepest point of ultrasound energy penetration and no intervening layers of tissue are spared in one  
5 embodiment of the present invention. In addition to ultrasound energy, other energy forms such as laser energy, radio frequency energy, and other energies can be used and fall within the scope of the present invention. Further, blue light at a wavelength of approximately 400 to 450 nm can be used to pre-treat ROI 210 before the application of ultrasound energy or blue light of this wavelength can be used with ultrasound to increase the efficacy of  
10 treatment. In another embodiment, visible light in the range of 600 to 1350 nm can be used with the ultrasound during treatment.

Upon treatment, the steps outlined herein can be repeated one or more additional times to provide for optimal treatment results. Different ablation sizes and shapes of conformal lesion 209 may affect the recovery time and time between treatments. For  
15 example, in general, the larger the surface area of conformal lesion 209, the faster the recovery. The series of treatments can also enable the user to tailor additional treatments in response to a patient's responses to the ultrasound treatment.

The methods of treatment described herein can employ various shaped conformal lesions 209 and can be produced using the various acoustic lenses and designs described  
20 herein. For example, mushroom shaped lesions may be produced from a spherically-focused source, and/or planar lesions from a flat source. That is, as the application of ablative ultrasound energy continues, this causes thermal expansion to generate a growing lesion. Concave planar sources and arrays can produce a "V-shaped" or ellipsoidal lesion. Electronic arrays, such as a linear array, can produce defocused, planar, or focused acoustic  
25 beams that may be employed to form a wide variety of additional lesion shapes at various depths. Other lesion shapes that may be useful with the treatment methods described herein include the lesion shapes and patterns described in the U.S. Patents and U.S. Patent Application that are incorporated by reference herein.

The citation of references herein does not constitute admission that those references  
30 are prior art or have relevance to the patentability of the invention disclosed herein. All references cited in the Description section of the specification are hereby incorporated by reference in their entirety for all purposes. In the event that one or more of the incorporated

references differs from or contradicts this application, including, but not limited to, defined terms, term usage, described techniques, or the like, this application controls.

The present invention has been described above with reference to various exemplary embodiments. However, those skilled in the art will recognize that changes and  
5 modifications may be made to the exemplary embodiments without departing from the scope of the present invention. For example, the various operational steps, as well as the components for carrying out the operational steps, may be implemented in alternate ways depending upon the particular application or in consideration of any number of cost  
10 functions associated with the operation of the system, e.g., various steps may be deleted, modified, or combined with other steps. These and other changes or modifications are intended to be included within the scope of the present invention, as set forth in the following claims.

**CLAIMS**

1. A method of non-invasive treatment of cellulite, the method comprising:  
targeting a region of interest below a surface of skin, said region of interest containing a fat lobuli;
- 5 delivering ultrasound energy to said region of interest;  
generating a conformal lesion with said ultrasound energy, said conformal lesion on a surface of said fat lobuli;  
creating an opening in said surface of said fat lobuli; and  
releasing a fluid out of said fat lobuli and through said opening in reducing an  
10 appearance of the cellulite on said surface of skin.
2. The method according to claim 1 further comprising heating said region of interest to a temperature in a range from about 43°C to about 49°C.
- 15 3. The method according to claim 2, wherein said heating said region of interest to a temperature in a range from about 43°C to about 49°C, stimulates apoptosis of at least one fat cell in said fat lobuli.
4. The method according to claim 2 further comprising monitoring a tissue  
20 temperature of said region of interest.
5. The method according to claim 1 further comprising applying a physical treatment to said surface of skin.
- 25 6. The method according to claim 5, wherein said physical treatment is at least one of massage, suction, pneumatic pressure, low frequency ultrasound, and RF energy.
7. The method according to claim 1 further comprising imaging said fat lobuli.
- 30 8. The method according to claim 7 further comprising imaging said fat lobuli during targeting of fat lobuli and during releasing fluid out of said fat lobuli..

9. The method according to claim 1 further reducing a layer of fat within said region of interest.

10. The method according to claim 1, wherein said ultrasound energy is in a  
5 frequency range of about 750 kHz to about 20 MHz.

11. The method according to claim 1 further comprising delivering a second energy to said region of interest, said second energy generated from a RF source.

10 12. A method of non-invasively reducing fat located in a subcutaneous fat layer, the method comprising:

targeting a plurality of fat cells in a subcutaneous layer below a skin surface;

delivering an energy to said fat cells;

raising a temperature of said fat cells into a range from about 43°C to about 49°C;

15 and

stimulating apoptosis of said fat cells, wherein a reduction in fat occurs through the dying off of said fat cells.

13. The method according to claim 12 further comprising imaging a portion of  
20 said plurality of fat cells.

14. The method according to claim 12 further comprising reducing a volume of said subcutaneous fat layer through applying a probe for delivering said energy along the skin surface.  
25

15. The method according to claim 12 further comprising generating a conformal lesion into said plurality of fat cells.

16. The method according to claim 15 further comprising creating an opening in  
30 said plurality of fat cells.

17. The method according to claim 16 further comprising moving a material out of said plurality of fat cells and through said openings.

18. The method according to claim 12, wherein said energy is in a frequency range of about 750 kHz to about 20 MHz.

5 19. The method according to claim 17 further delivering a second energy to said plurality of fat cells to facilitate movement of said material.

20. The method according to claim 19 wherein said delivering a second energy to said plurality of fat cells is at least one of before, after, and concurrent with said delivering an energy to said plurality of fat cells.  
10

21. A non-invasive method for treatment of cellulite on and for fat reduction beneath and the skin, the method comprising:

targeting fat lobuli within a region of interest;  
15 delivering ultrasound energy to said region of interest to generate a conformal lesion in a portion of said fat lobuli;  
creating an opening in a surface of said fat lobuli with said conformal lesion;  
removing a fluid out of said fat lobuli and through said opening thereby reducing appearance of cellulite on the skin;  
20 targeting fat cells in a subcutaneous layer below a skin surface;  
delivering a second energy to said fat cells in said region of interest;  
raising a temperature of said fat cells to a range from about 43°C to about 49°C; and  
stimulating apoptosis of said fat cells to destroy said fat cells thereby reducing fat  
beneath the skin.

25 22. The method according to claim 21 further comprising imaging at least one of said fat lobuli and said fat cells.

30 23. The method according to claim 21 further comprising applying a physical treatment to said surface of skin.

24. The method according to claim 23, wherein said physical treatment is at least one of massage, suction, pneumatic pressure, low frequency ultrasound, and RF energy.

25. The method according to claim 21 further reducing said appearance of cellulite on said skin.

5 26. The method according to claim 21 further comprising reducing an amount of fat in a subcutaneous fat layer.

27. The method according to claim 21, wherein at least one of said first energy and said second energy is in a frequency range of about 750 kHz to about 20 MHz.

10

28. The method according to claim 21, wherein said generating a conformal lesion provides at least one of physically breaking fat cell clusters and stretching fibrous bonds of said cellulite.

15

29. A method for a non-invasive treatment of cellulite, the method comprising:  
identifying a fat lobuli,  
creating a sharp focal of ultrasound energy onto said fat lobuli; and  
piercing said fat lobuli to create an opening to facilitate removal of a material out of said fat lobuli through said opening.

20

30. The method according to claim 29 further comprising applying a physical treatment to said fat lobuli.

25

31. The method according to claim 30, wherein said physical treatment is at least one of massage, suction, pneumatic pressure, low frequency ultrasound, and RF energy.

32. The method according to claim 29 further reducing an appearance of cellulite on a skin surface.

30

33. The method according to claim 29 further comprising imaging said fat lobuli.

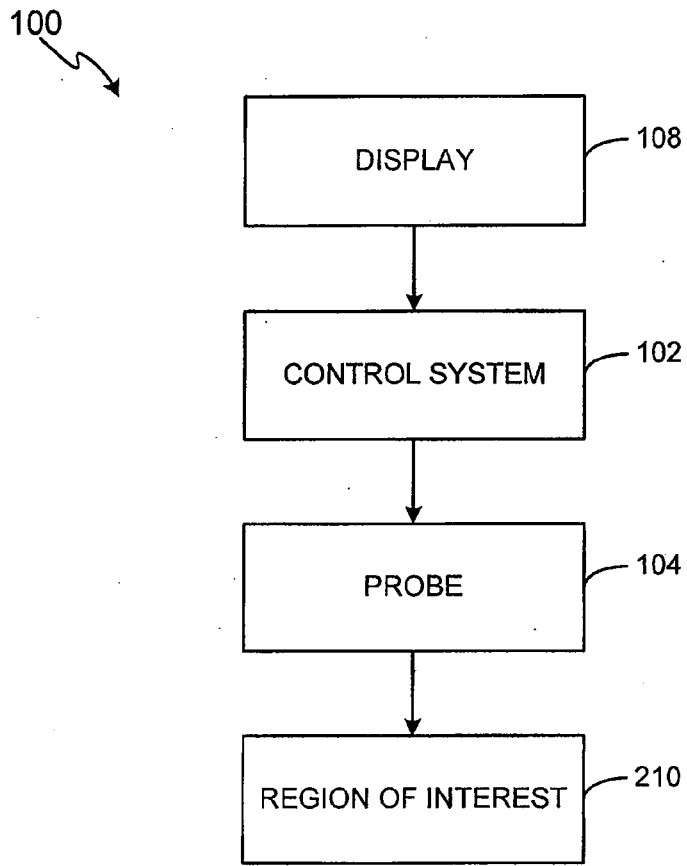

**FIG. 1**

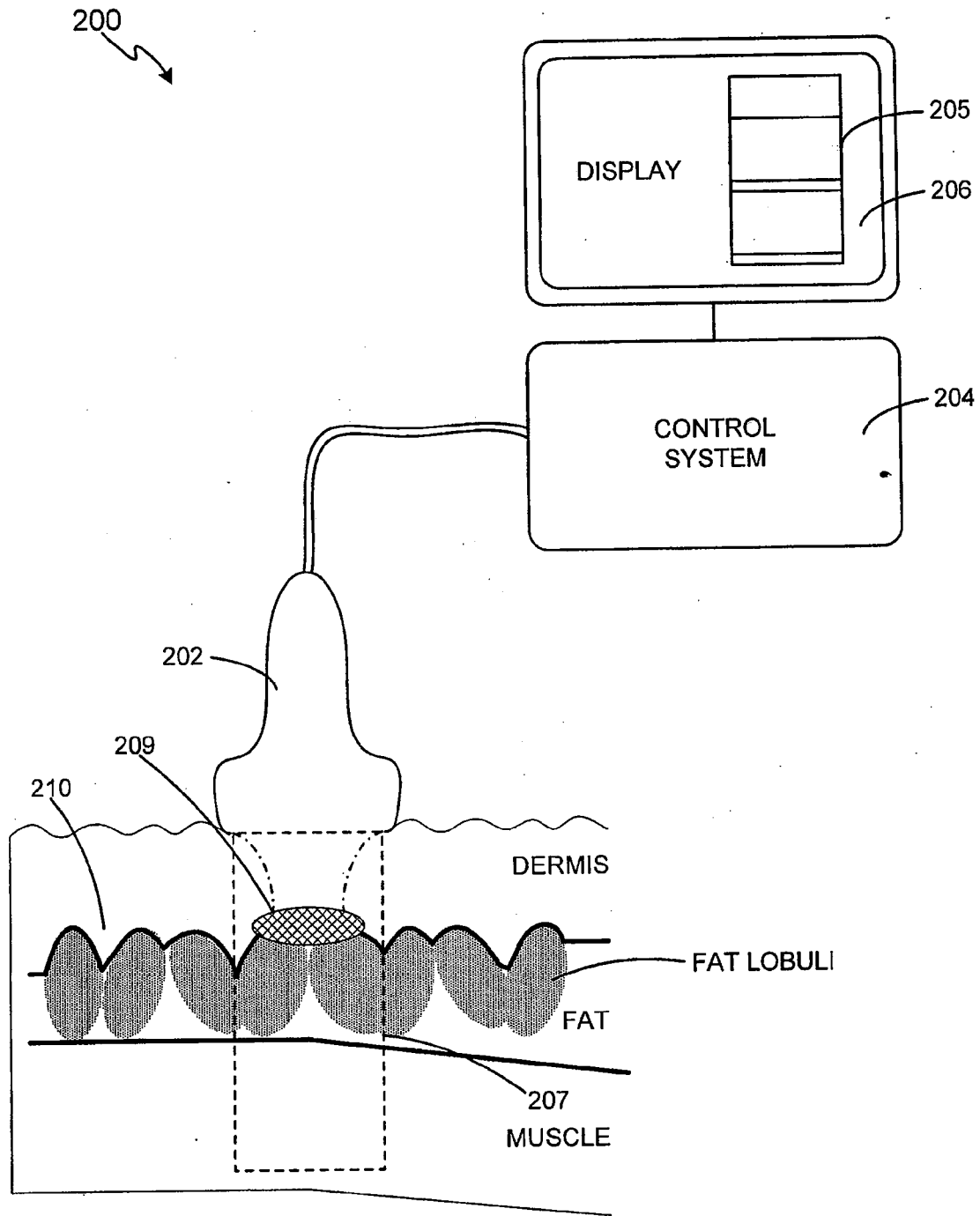
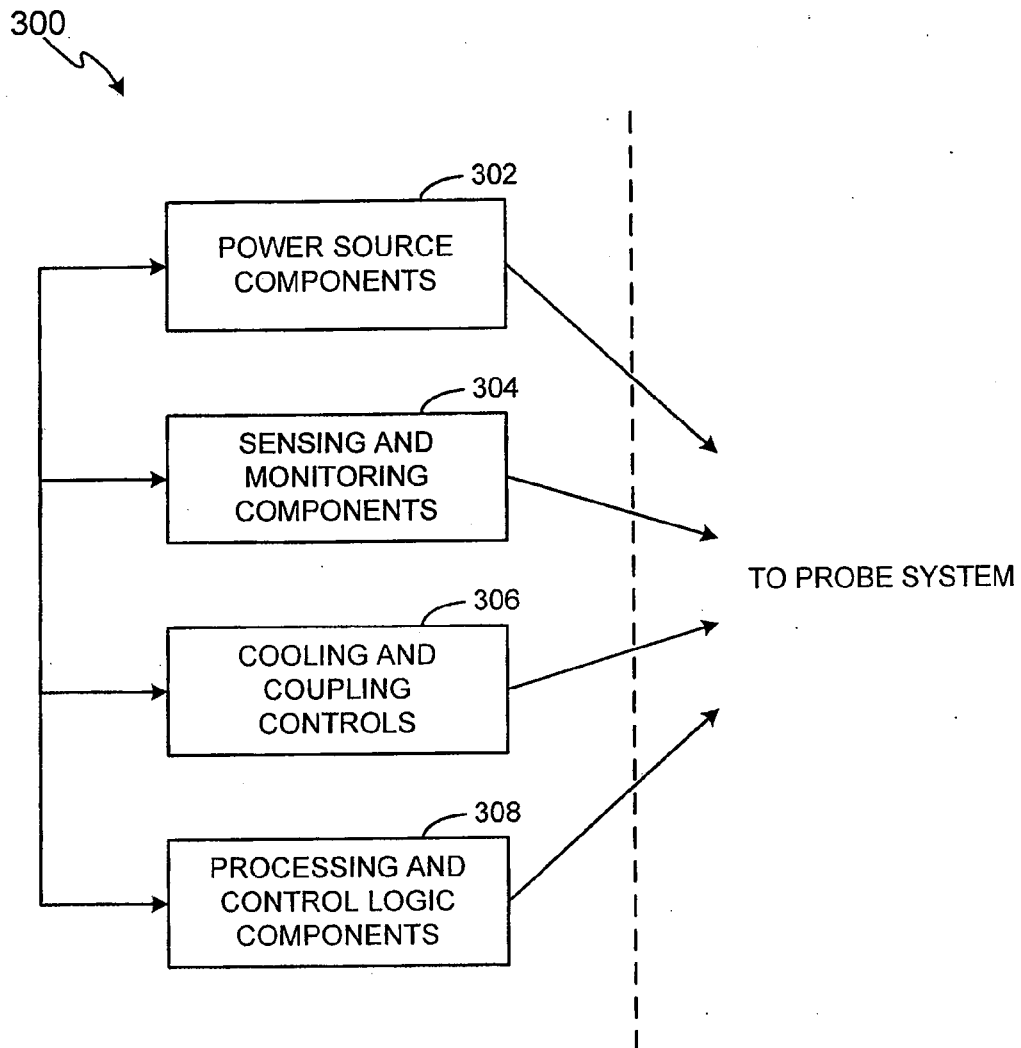

FIG. 2



**FIG. 3A**

4/27

300 ↘

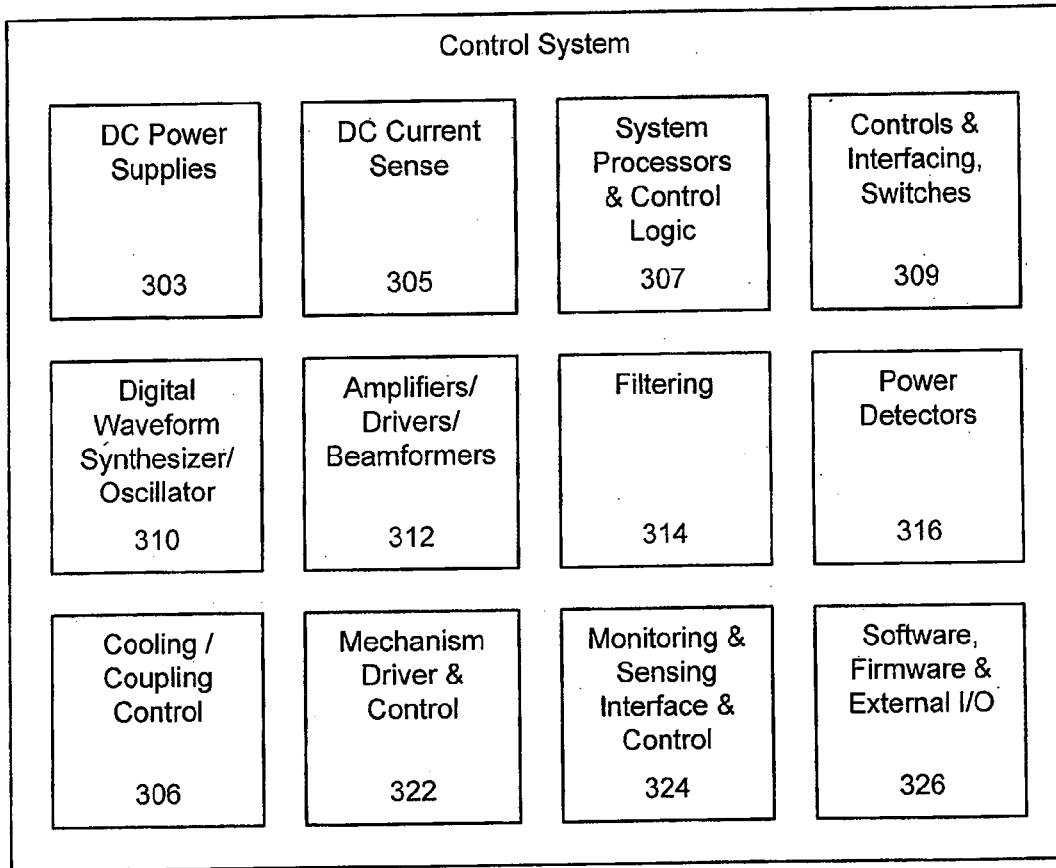

**FIG. 3B**

5/27

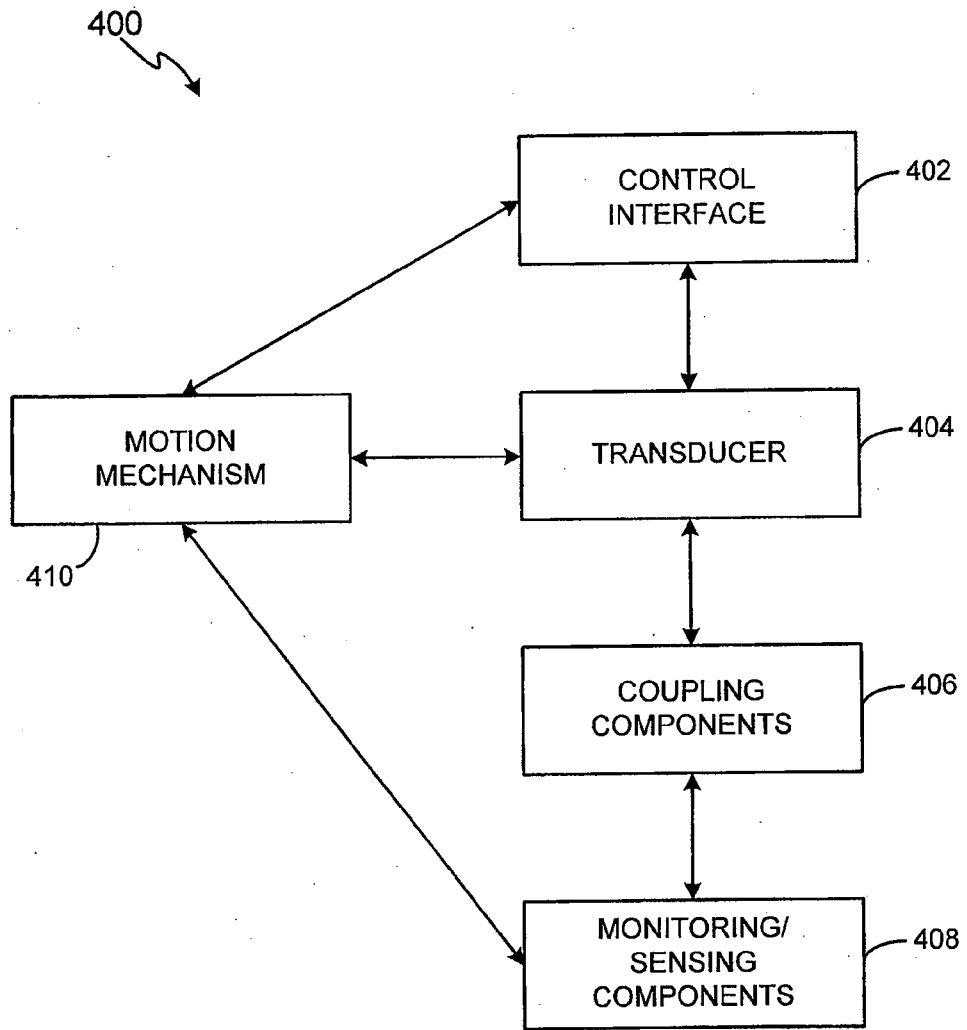

FIG. 4A

6/27

400 ↘

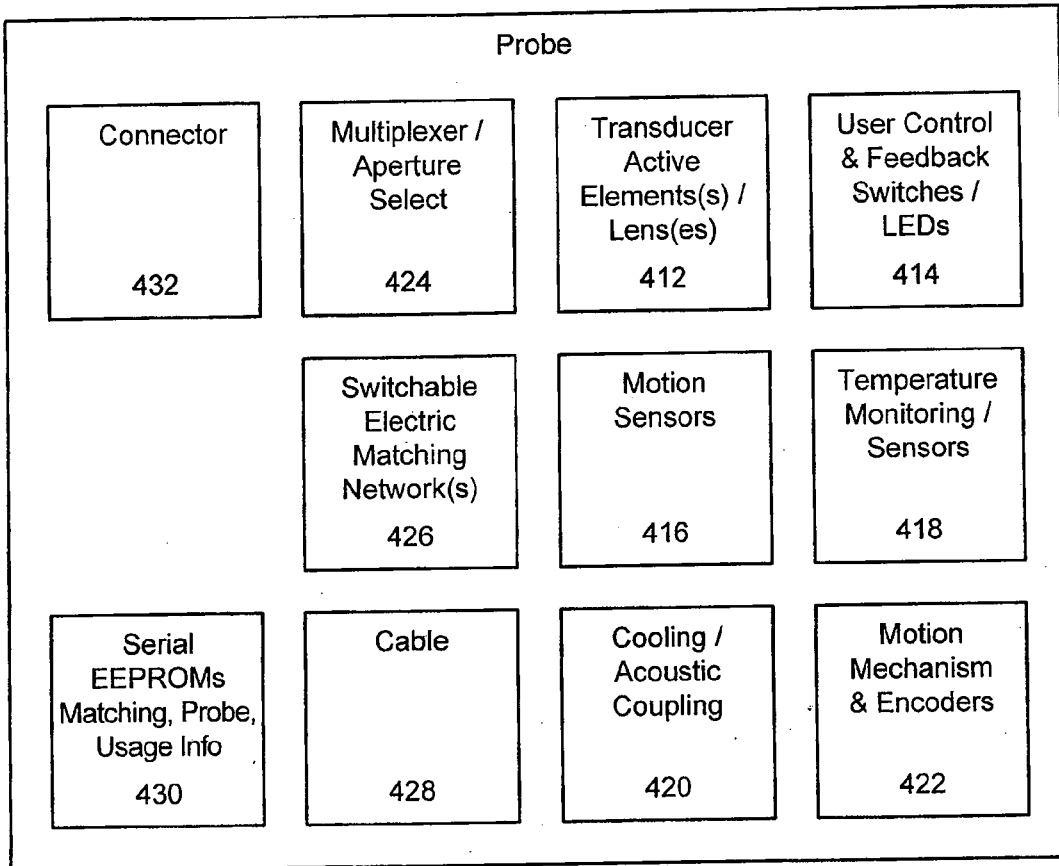

FIG. 4B

7/27

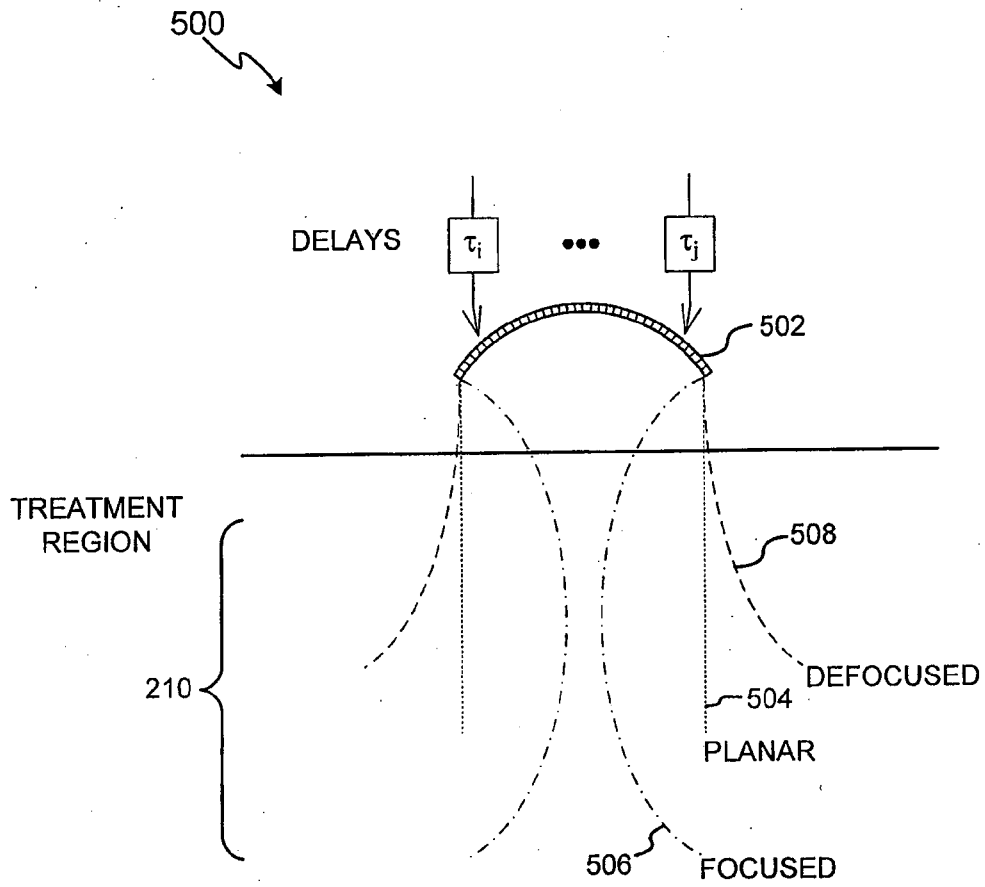

FIG. 5

8/27

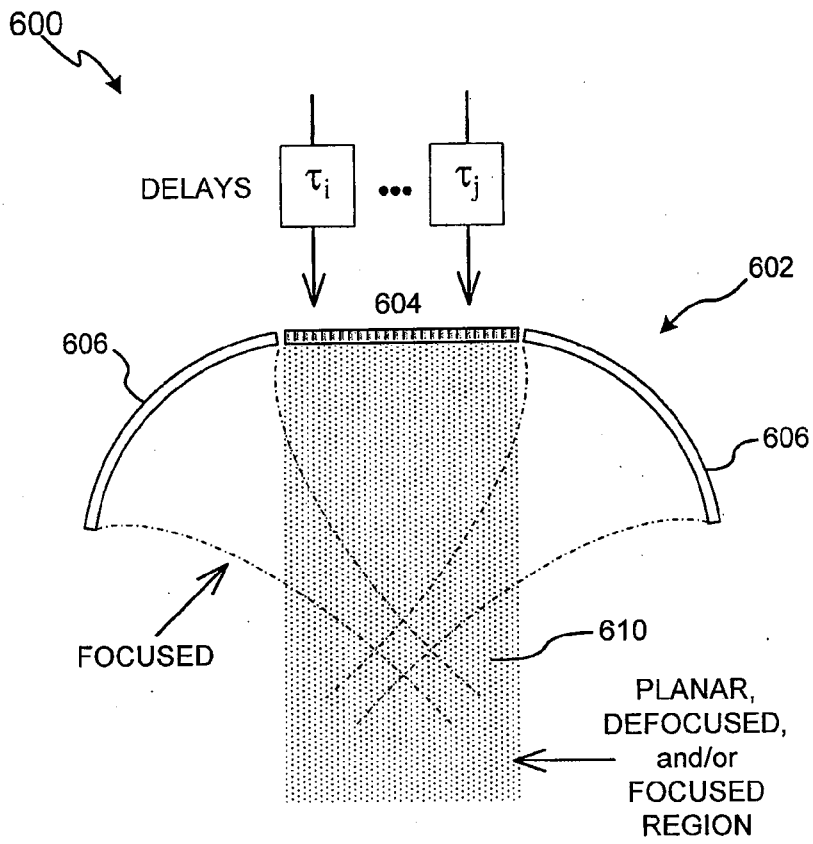

FIG. 6A

9/27

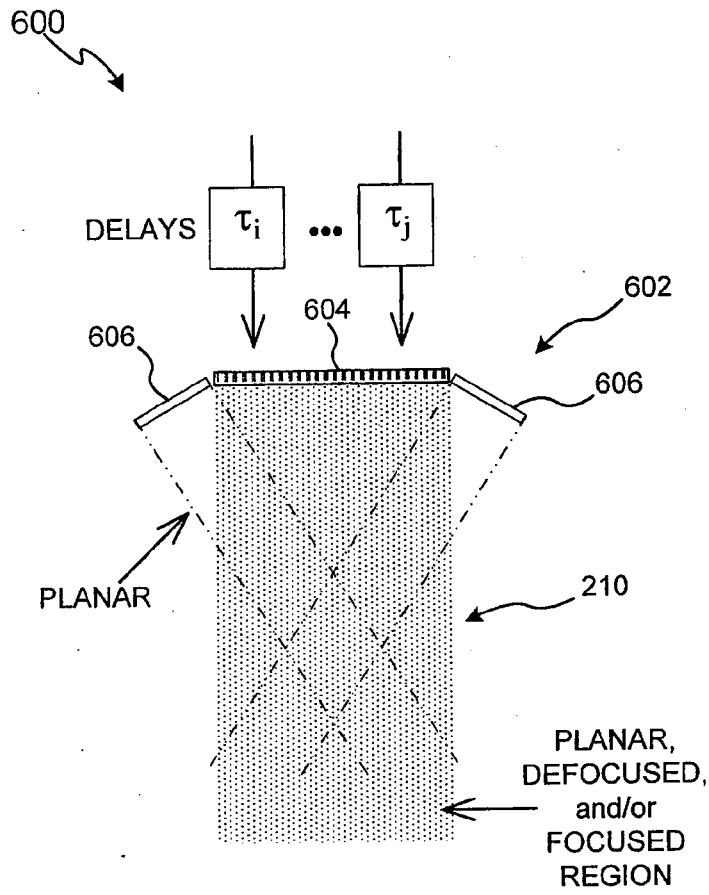

FIG. 6B

10/27

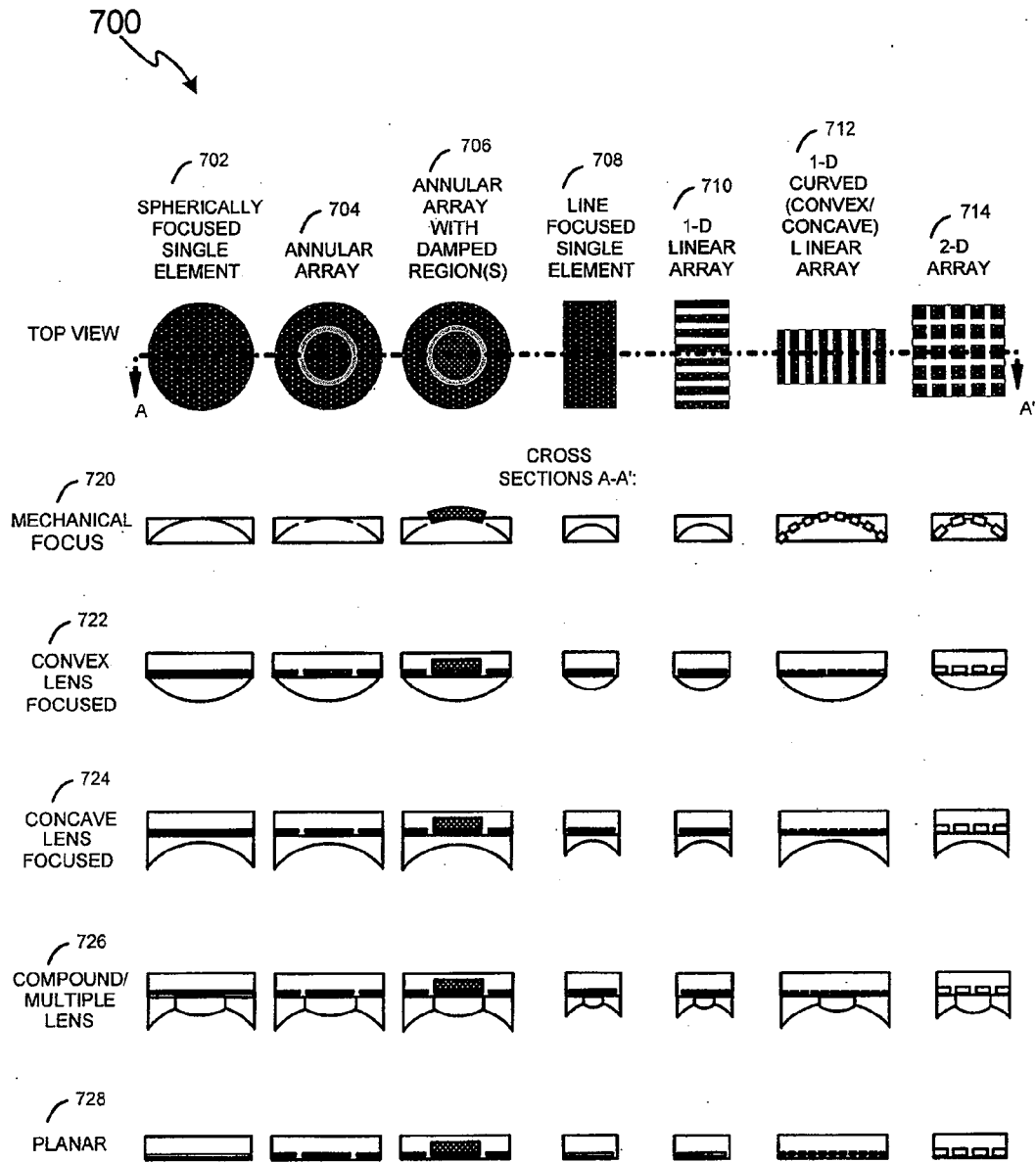

FIG. 7

11/27

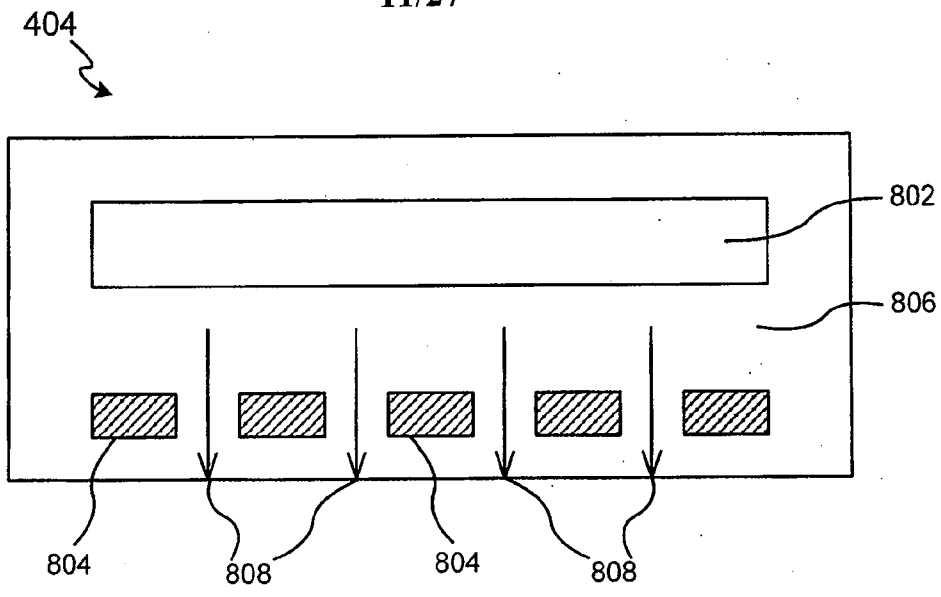

FIG. 8A

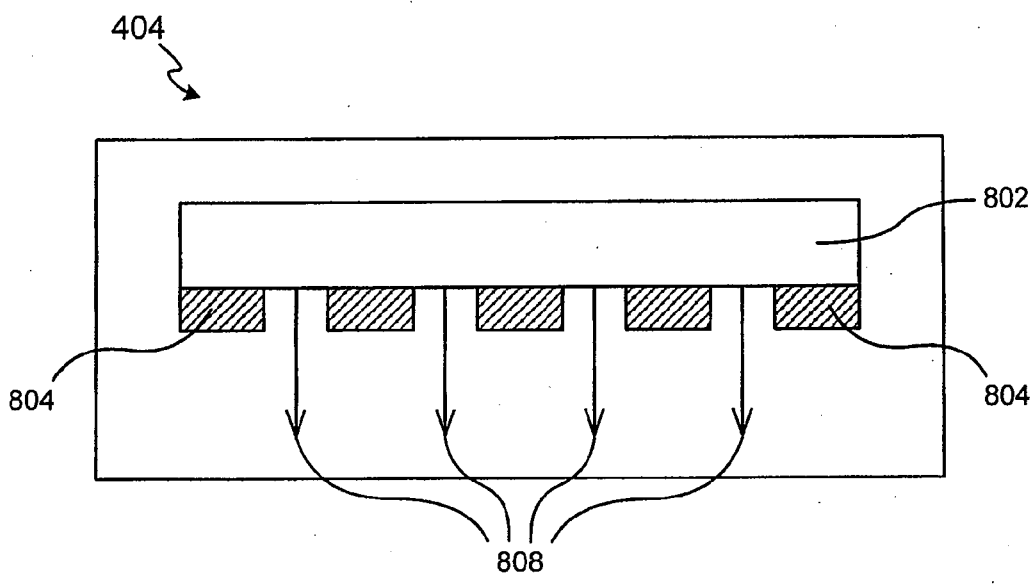

FIG. 8B

12/27

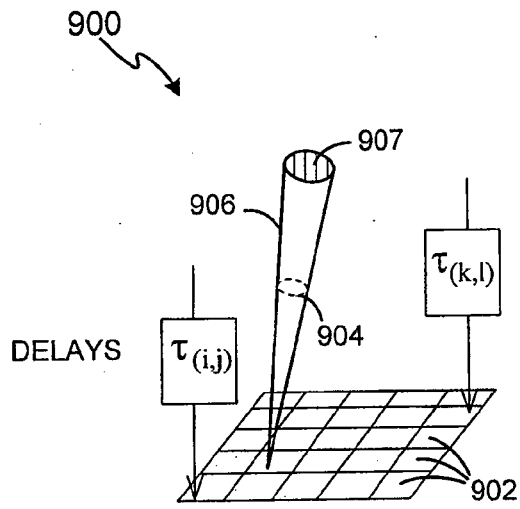

FIG. 9

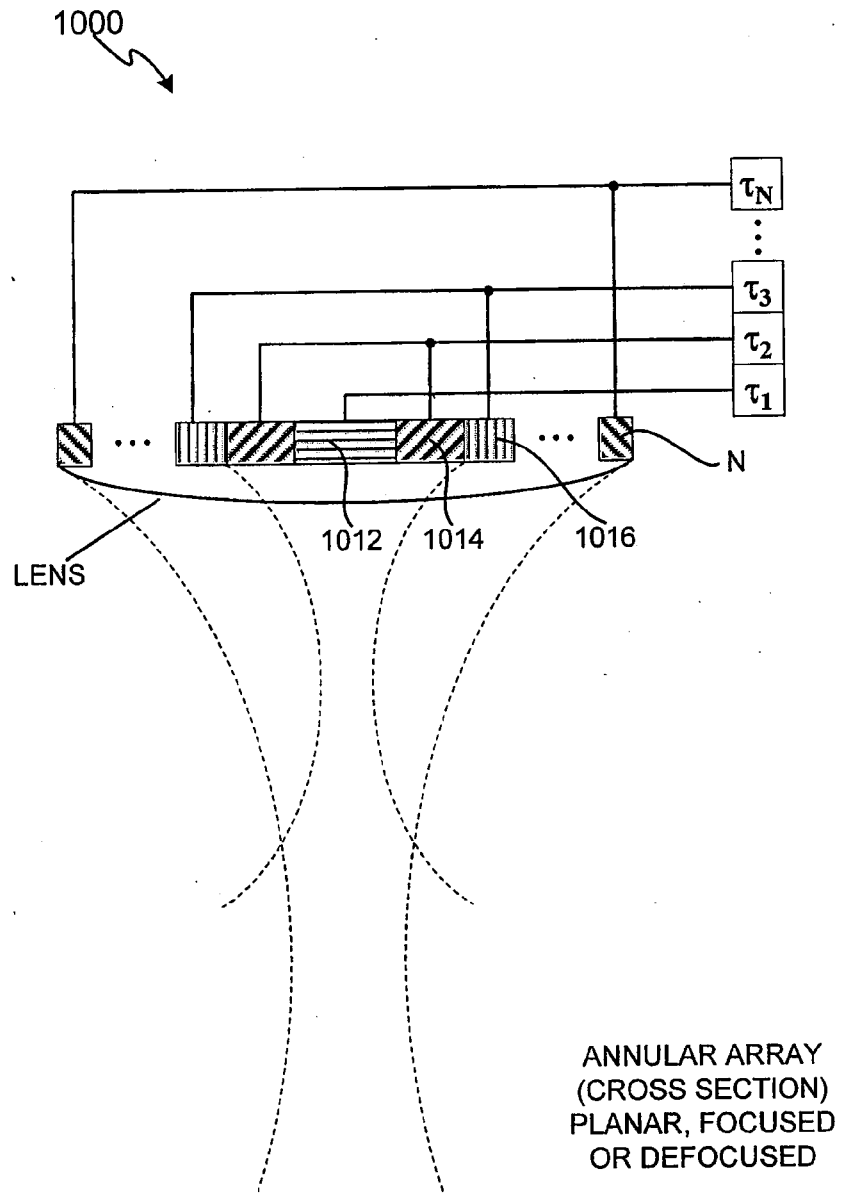

FIG. 10A

14/27

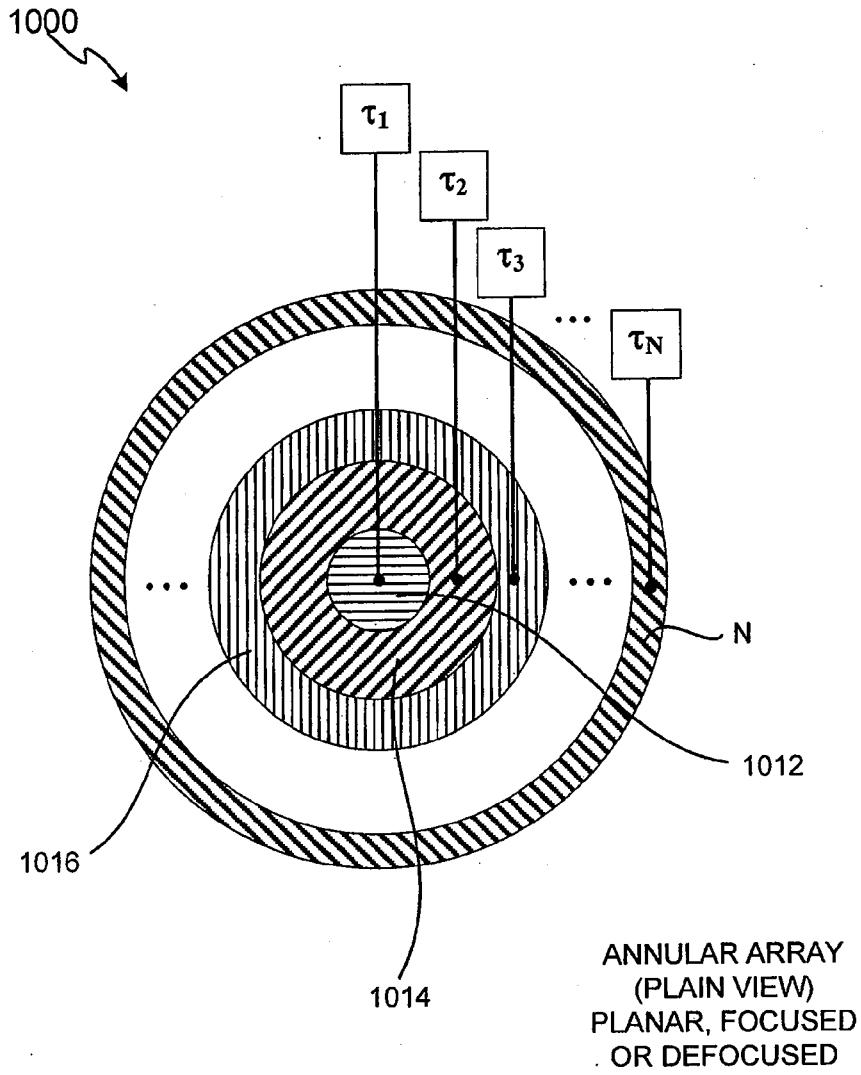

FIG. 10B

15/27

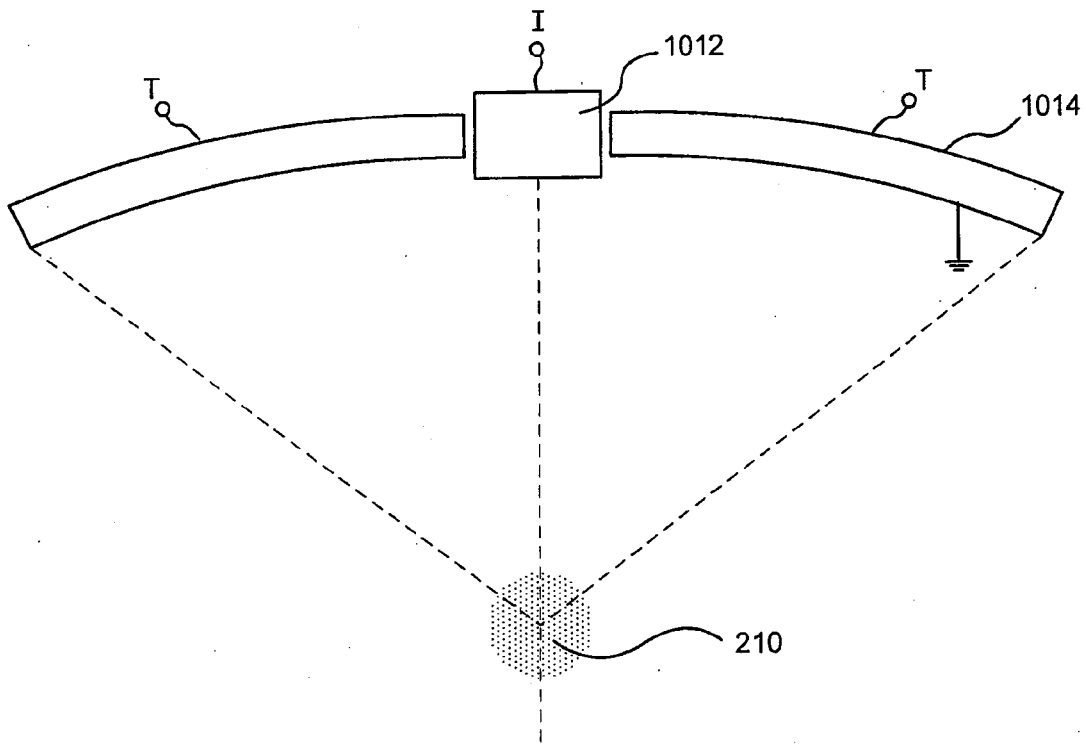

FIG. 10C

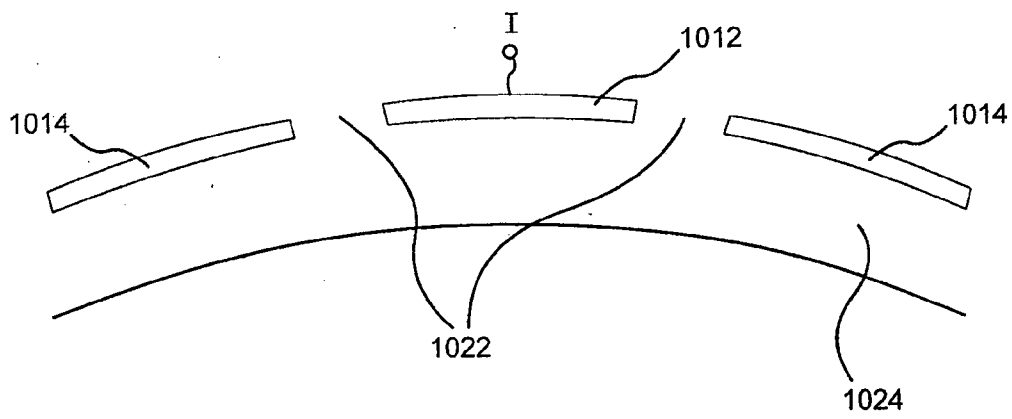
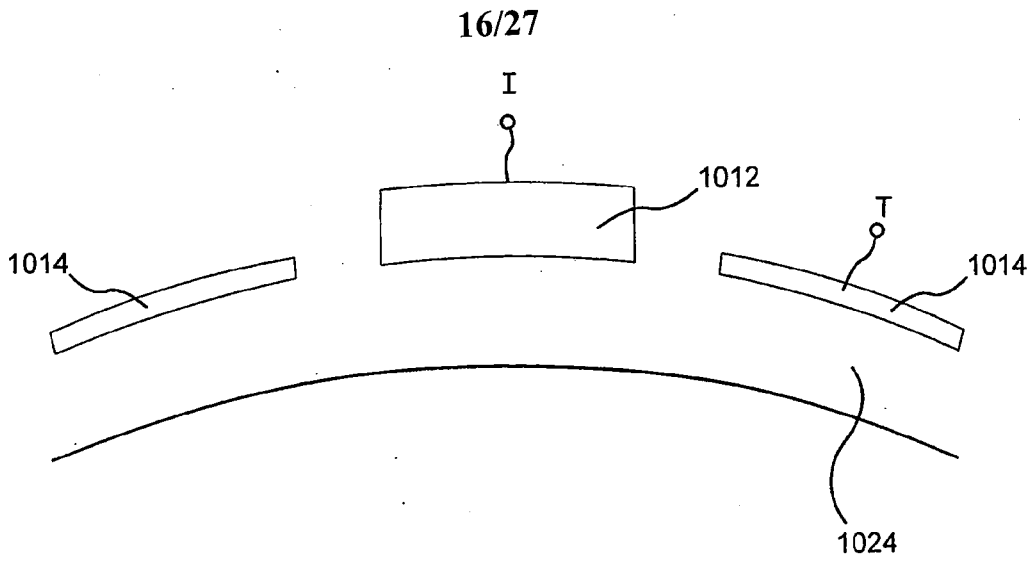
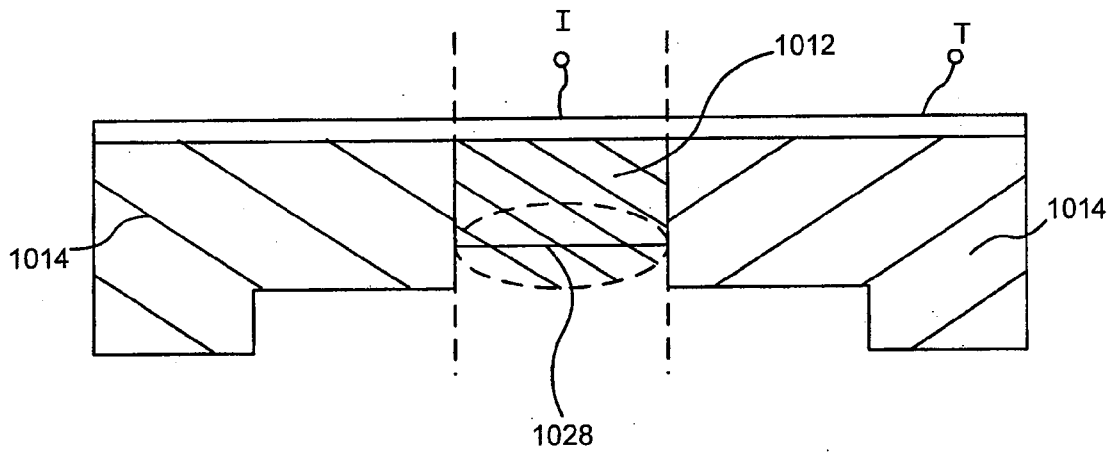

FIG. 10D



**FIG. 10E**



**FIG. 10F**

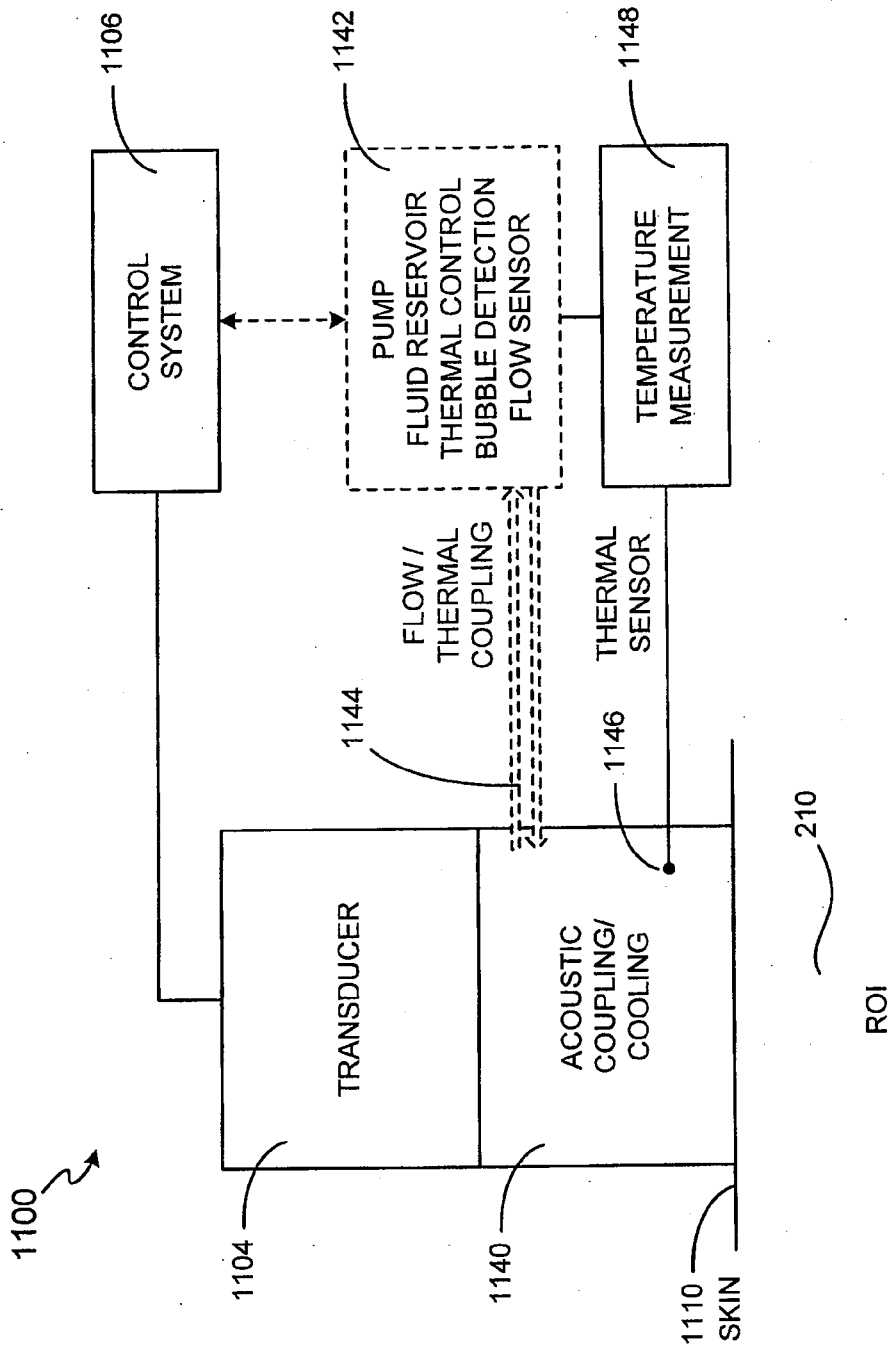
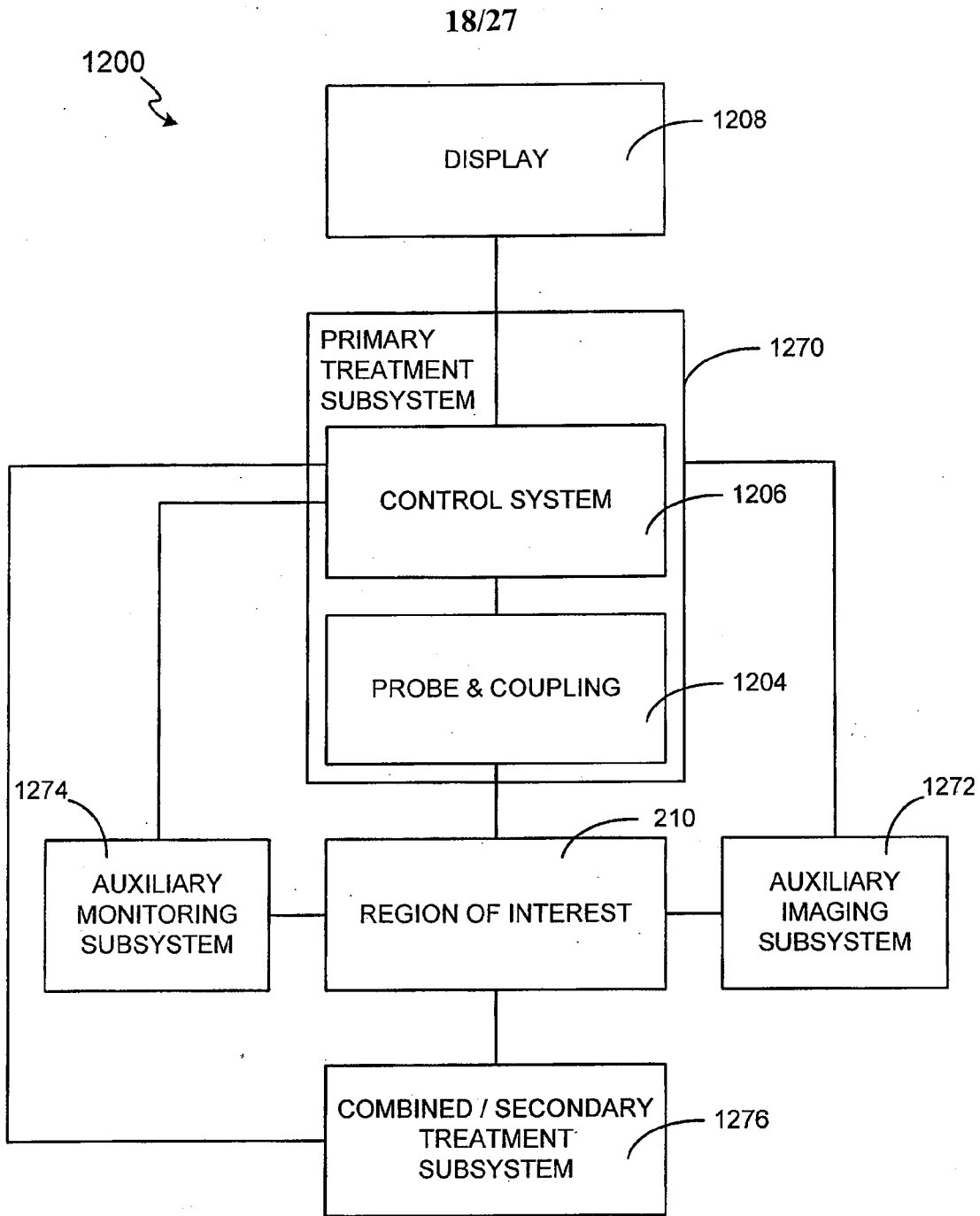

FIG. 11



**FIG. 12**

19/27

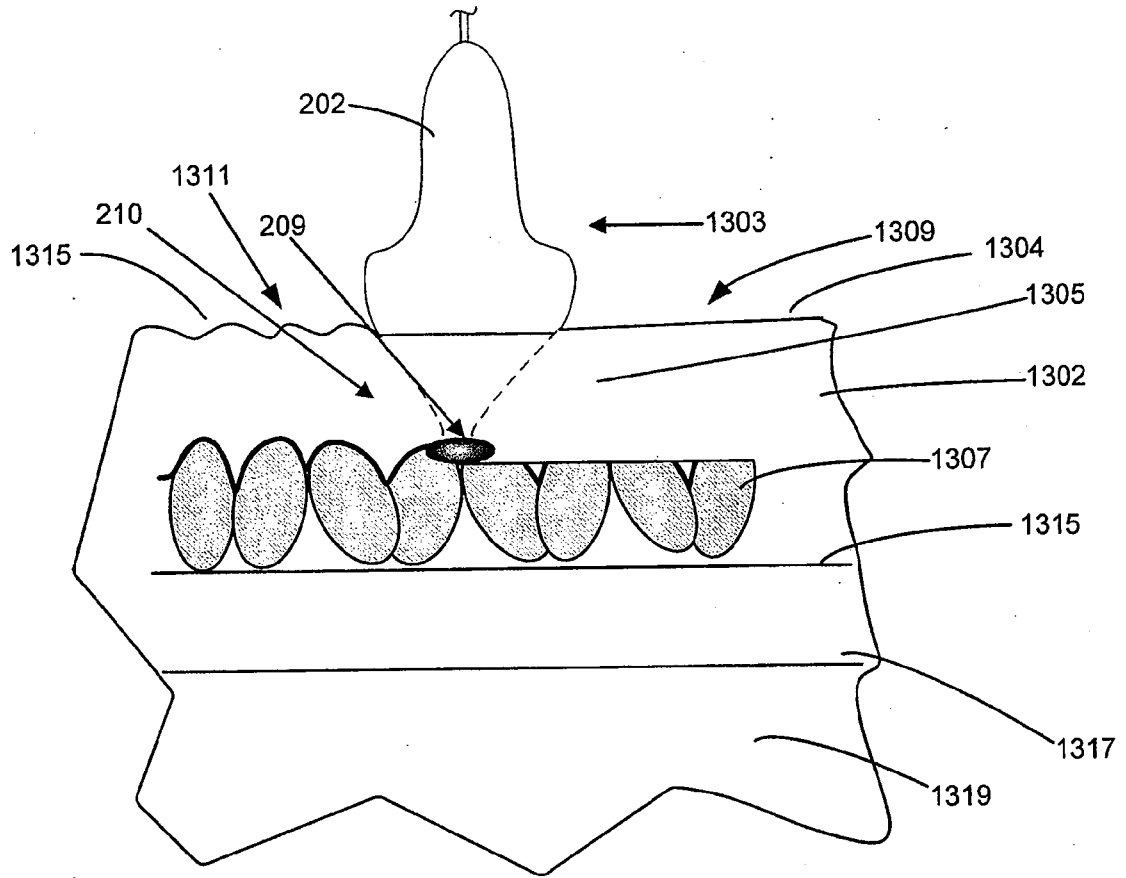

FIG. 13

20/27

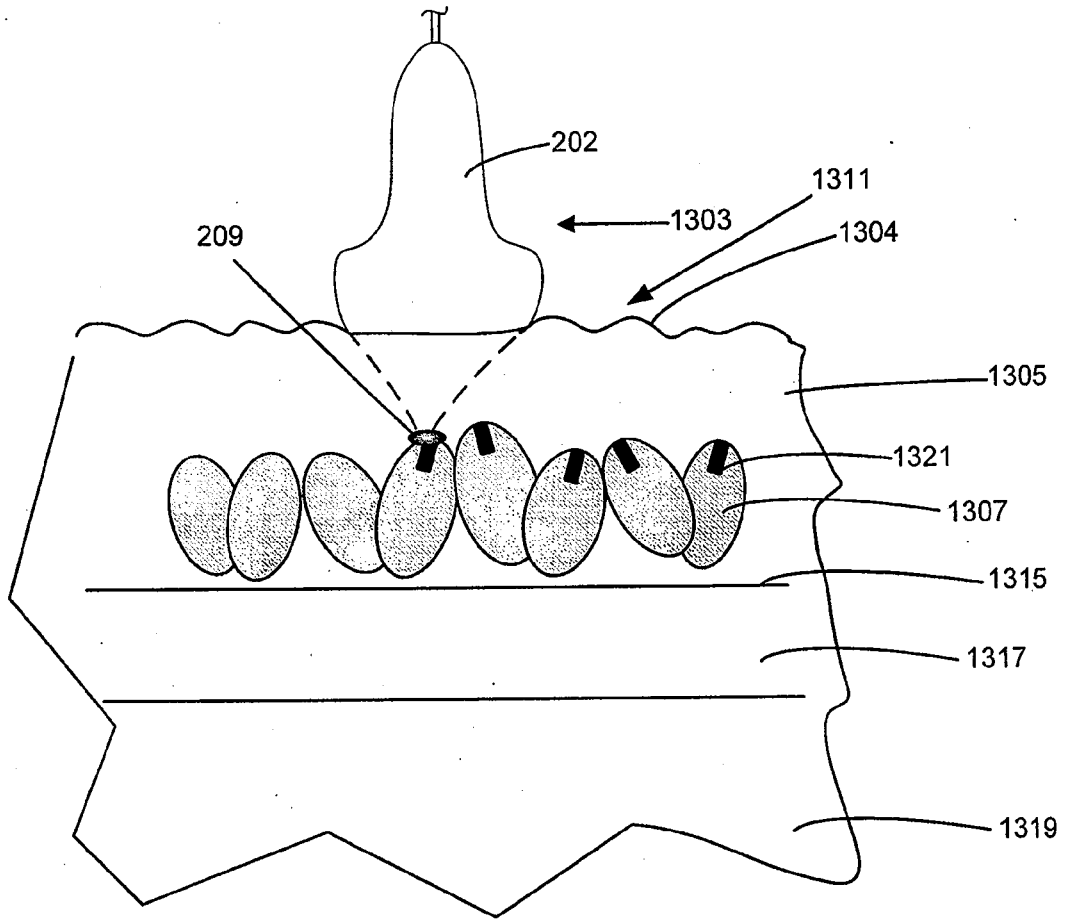
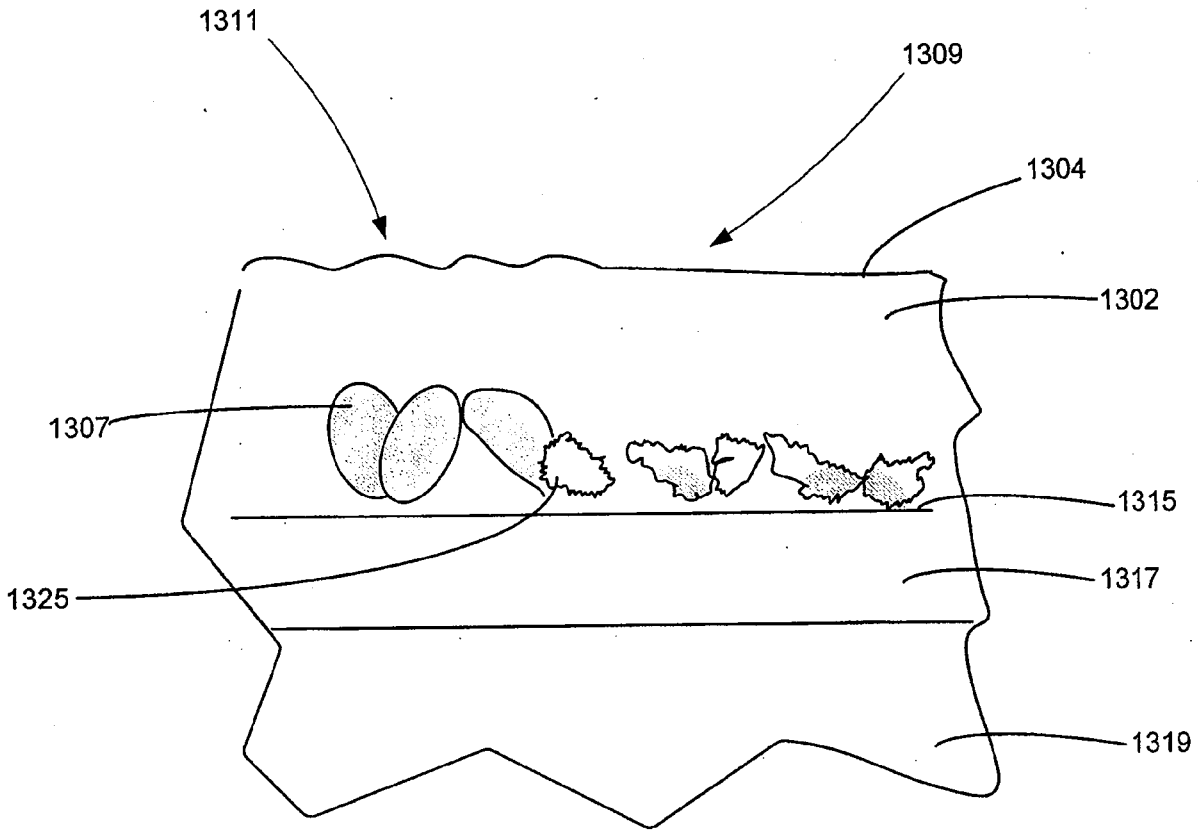

FIG. 14A

21/27



**FIG. 14B**

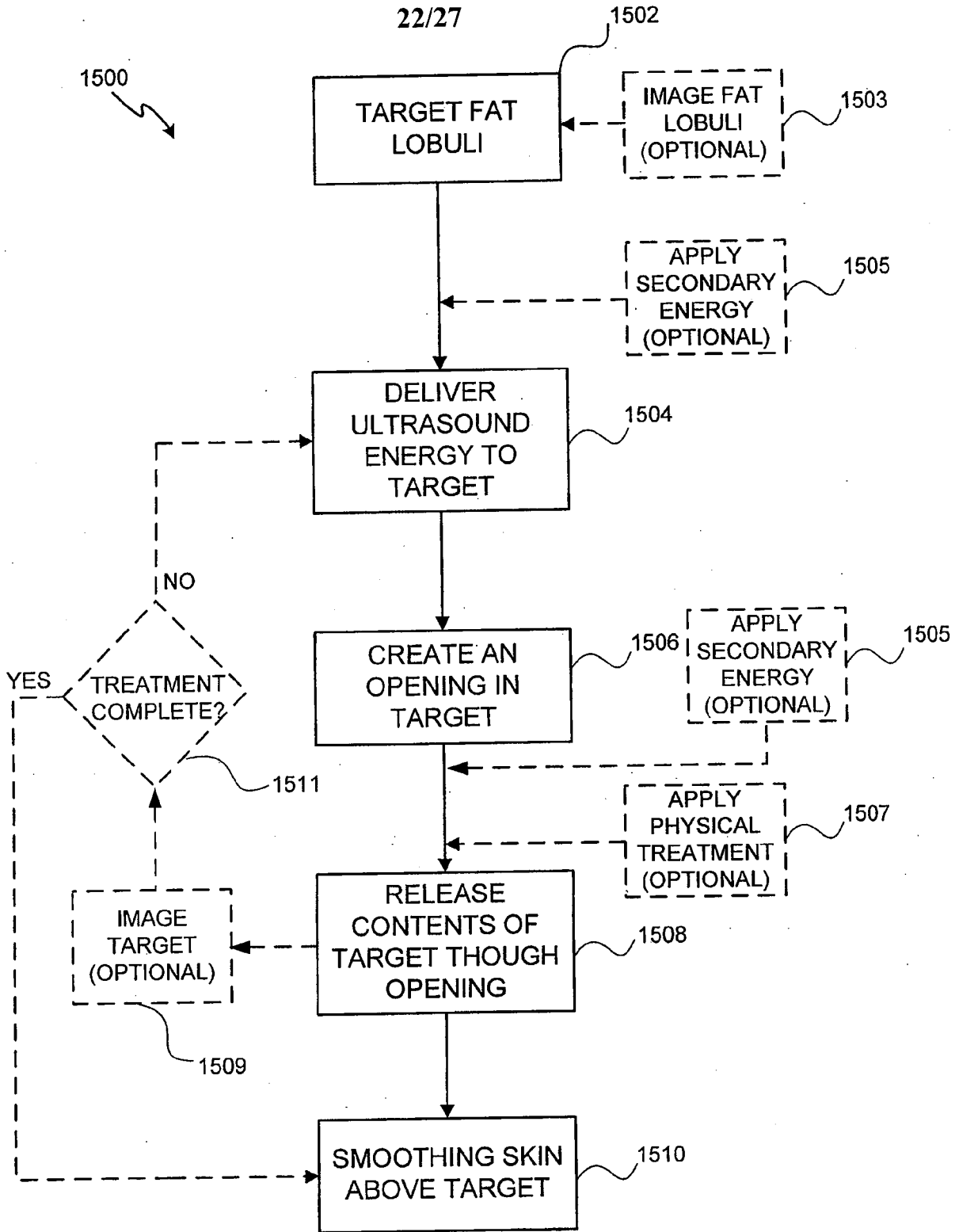

FIG. 15

23/27

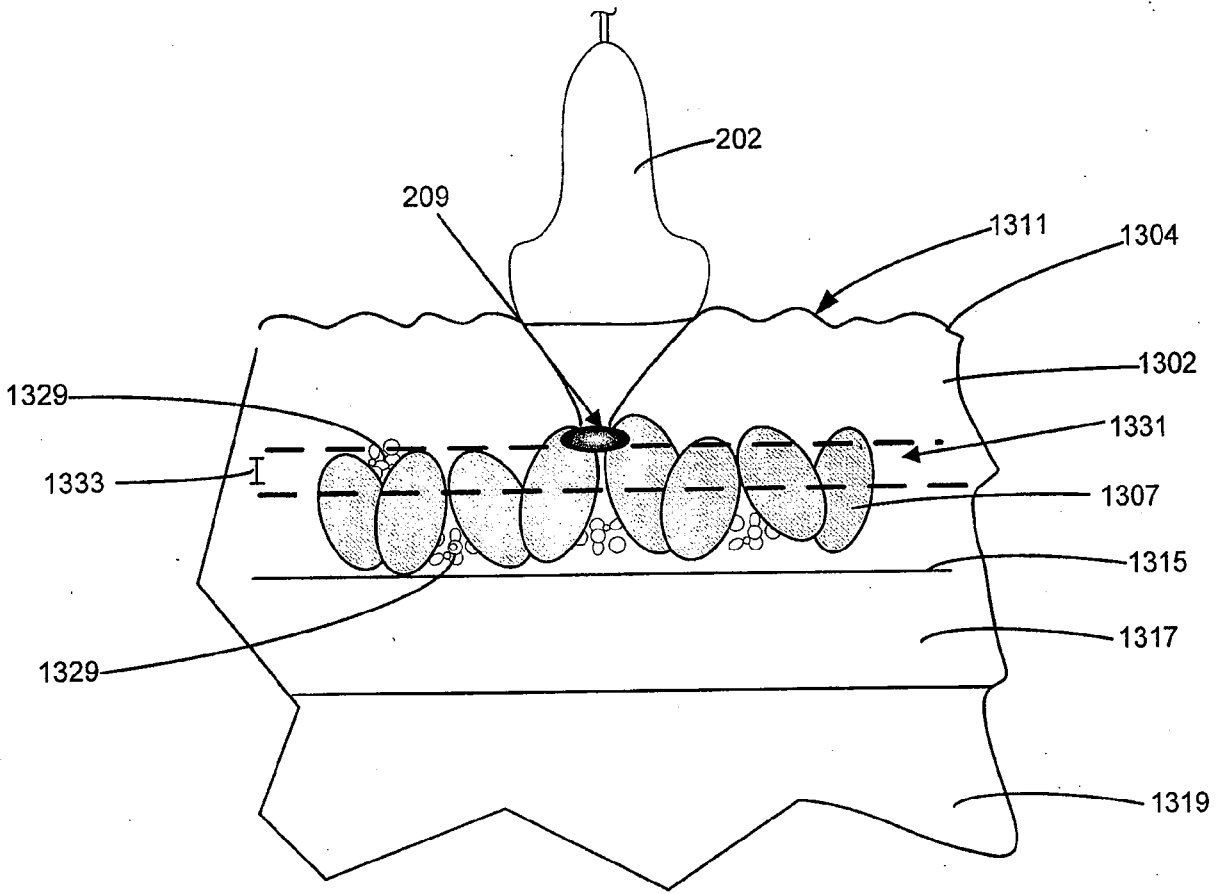
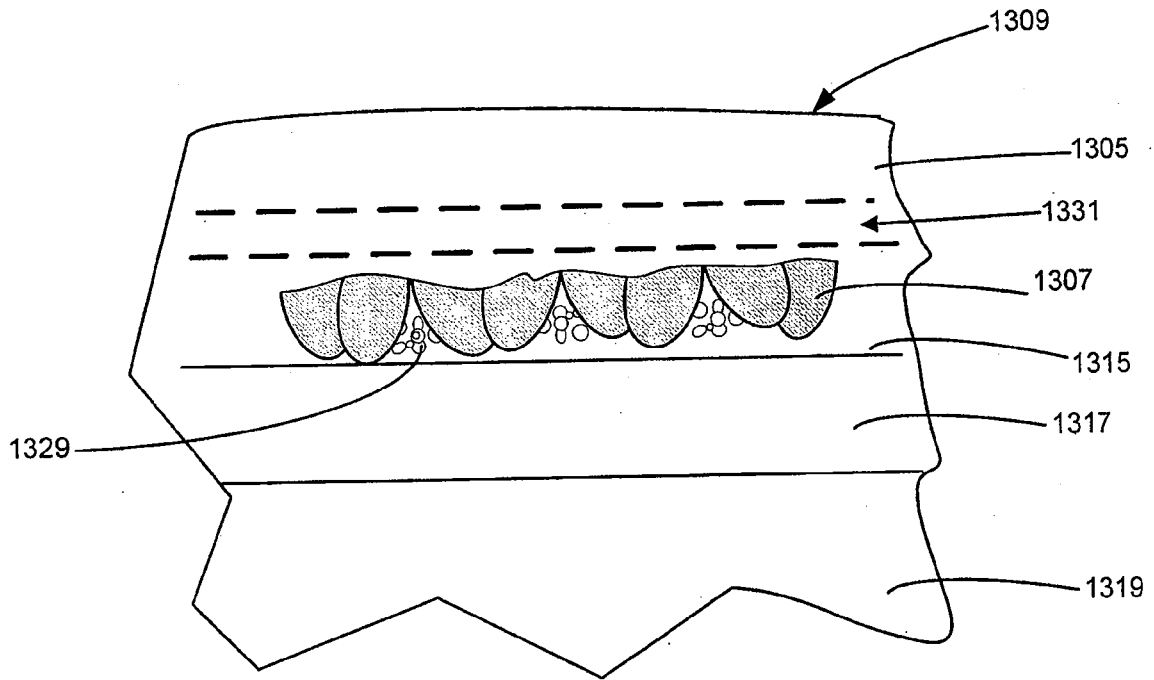
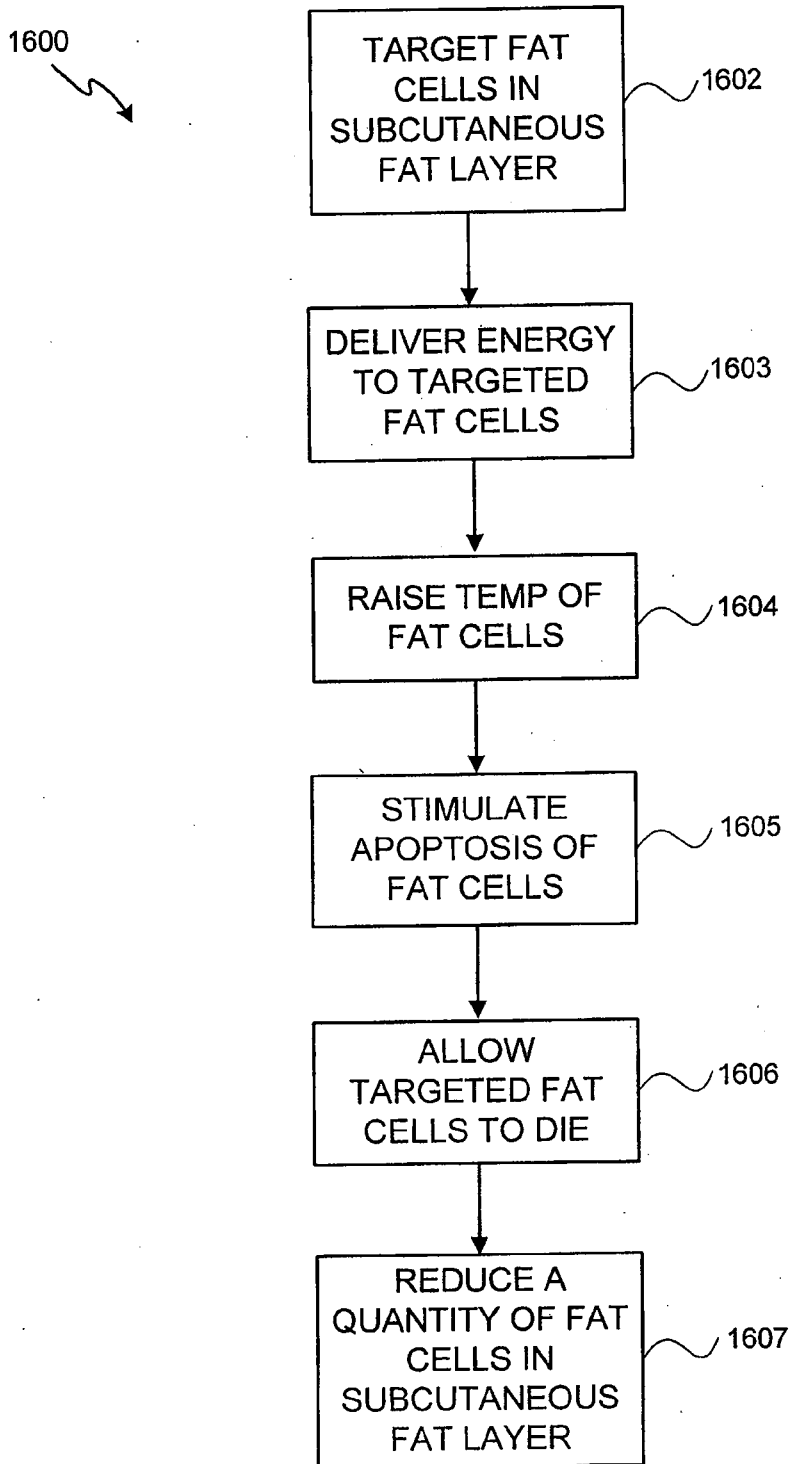

FIG. 16A



**FIG. 16B**



**FIG. 17**

26/27

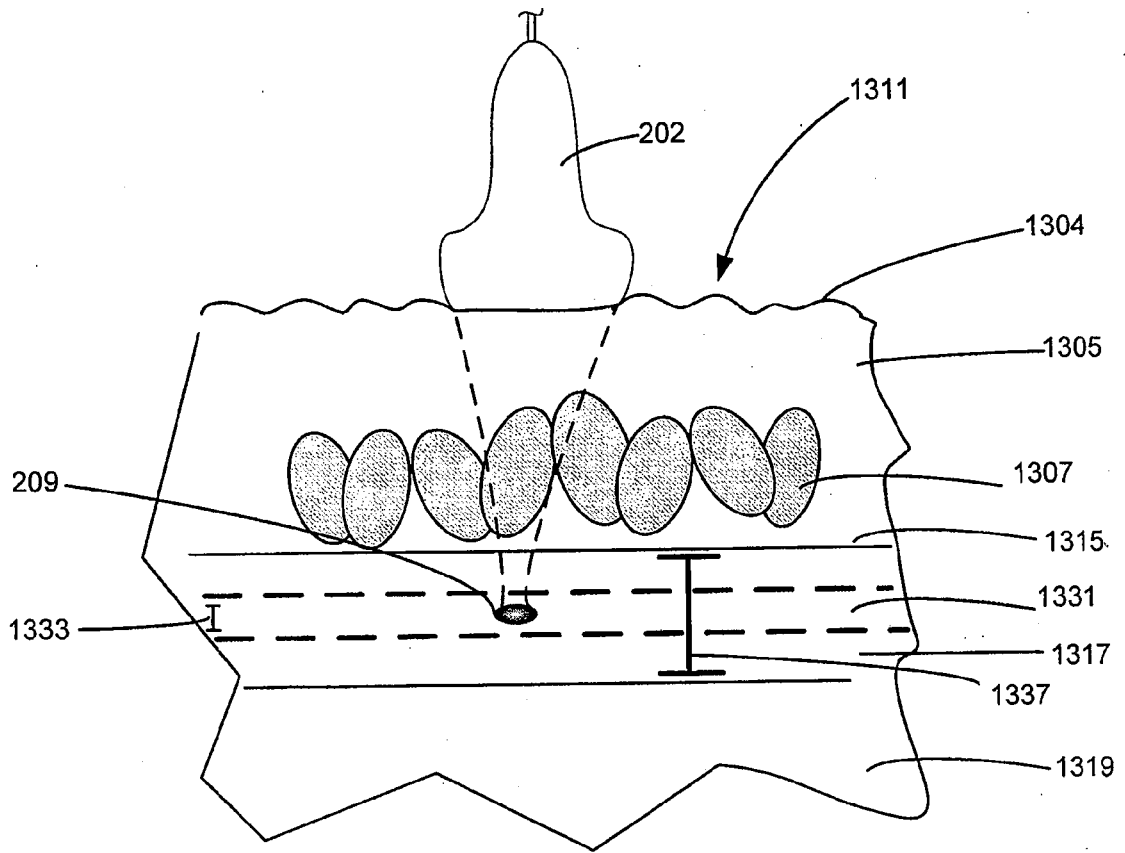

FIG. 18A

27/27

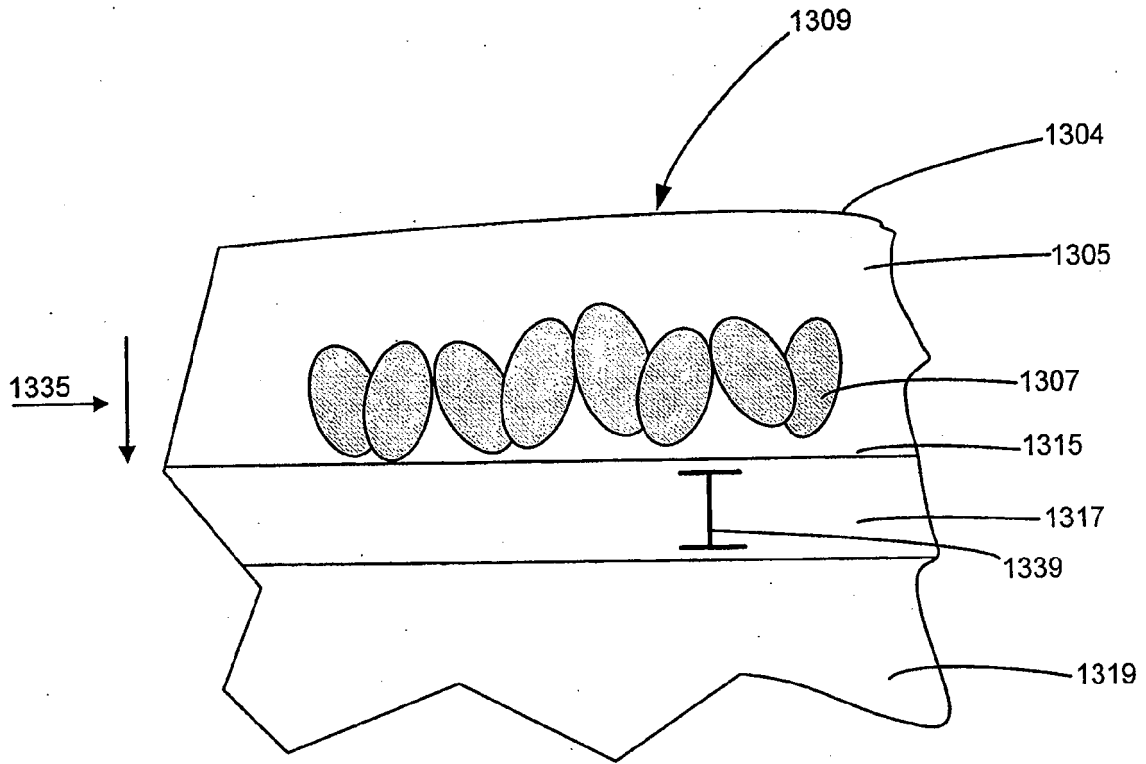

FIG. 18B

专利名称(译)	用于减少脂肪和/或脂肪团治疗的方法和系统		
公开(公告)号	<a href="#">EP2382010A4</a>	公开(公告)日	2014-05-14
申请号	EP2009835856	申请日	2009-12-23
申请(专利权)人(译)	引导治疗系统公司		
当前申请(专利权)人(译)	引导治疗系统公司		
[标]发明人	SLAYTON MICHAEL H BARTHE PETER G		
发明人	SLAYTON, MICHAEL H. BARTHE, PETER G.		
IPC分类号	A61N7/00 A61B18/00 A61B5/00 A61B8/00 A61B8/08 A61B8/14 A61B19/00 A61N7/02 B06B1/06 G01S7/52 G01S15/89		
CPC分类号	A61B5/4869 A61B8/0858 A61B8/14 A61B8/429 A61B8/4455 A61B8/4483 A61B8/483 A61B2090/378 A61N7/02 A61N2007/0008 A61N2007/0052 B06B1/0622 G01S7/5208 G01S15/8906 G01S15/899 G01S15/8993 A61N7/00 A61N2007/027 B06B1/0607 H05K999/99		
优先权	61/140725 2008-12-24 US		
其他公开文献	EP2382010A2		
外部链接	<a href="#">Espacenet</a>		

#### 摘要(译)

用于非侵入性减少脂肪的系统和方法可以包括靶向皮肤表面下方的包含脂肪的感兴趣区域，并将超声能量传递到该感兴趣区域。超声能量利用脂肪能量上的所述超声能量产生热损伤。病变可在脂肪细胞表面形成开口，从而允许流体从脂肪细胞中排出并通过开口。另外，通过向脂肪细胞施加超声能量以将温度升高至43度至49度之间，可以实现细胞凋亡，从而导致脂肪减少。