

(19) World Intellectual Property
Organization
International Bureau



(43) International Publication Date
23 December 2004 (23.12.2004)

PCT

(10) International Publication Number
WO 2004/110263 A1

(51) International Patent Classification⁷: A61B 5/00

CO, CR, CU, CZ, DE, DK, DM, DZ, EC, EE, EG, ES, FI, GB, GD, GE, GH, GM, HR, HU, ID, IL, IN, IS, JP, KE, KG, KP, KR, KZ, LC, LK, LR, LS, LT, LU, LV, MA, MD, MG, MK, MN, MW, MX, MZ, NA, NI, NO, NZ, OM, PG, PH, PL, PT, RO, RU, SC, SD, SE, SG, SK, SL, SY, TJ, TM, TN, TR, TT, TZ, UA, UG, US, UZ, VC, VN, YU, ZA, ZM, ZW.

(21) International Application Number:
PCT/EP2004/051121

(22) International Filing Date: 15 June 2004 (15.06.2004)

(25) Filing Language: English

(84) Designated States (unless otherwise indicated, for every kind of regional protection available): ARIPO (BW, GH, GM, KE, LS, MW, MZ, NA, SD, SL, SZ, TZ, UG, ZM, ZW), Eurasian (AM, AZ, BY, KG, KZ, MD, RU, TJ, TM), European (AT, BE, BG, CH, CY, CZ, DE, DK, EE, ES, FI, FR, GB, GR, HU, IE, IT, LU, MC, NL, PL, PT, RO, SE, SI, SK, TR), OAPI (BF, BJ, CF, CG, CI, CM, GA, GN, GQ, GW, ML, MR, NE, SN, TD, TG).

(26) Publication Language: English

(30) Priority Data:
03101769.2 17 June 2003 (17.06.2003) EP

(71) Applicant and

(72) Inventor: MOSER, Raymond [CH/CH]; Chemin du Croset 11, CH-1024 Ecublens (CH).

Published:

- with international search report
- before the expiration of the time limit for amending the claims and to be republished in the event of receipt of amendments

(74) Agent: SAAM, Christophe; Patents & Technology Surveys Ltd, Terreaux 7, CH-2001 Neuchâtel (CH).

(81) Designated States (unless otherwise indicated, for every kind of national protection available): AE, AG, AL, AM, AT, AU, AZ, BA, BB, BG, BR, BW, BY, BZ, CA, CH, CN,

For two-letter codes and other abbreviations, refer to the "Guidance Notes on Codes and Abbreviations" appearing at the beginning of each regular issue of the PCT Gazette.

(54) Title: INSTRUMENTED RETRIEVABLE IMPLANTABLE DEVICE

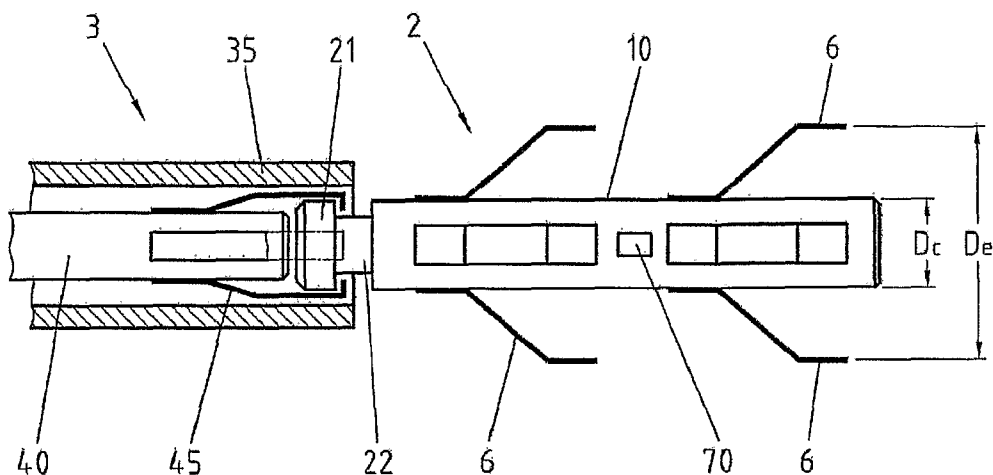

(57) Abstract: Instrumented retrievable implantable device (2), comprising an expandable section, for placement inside a body lumen, preferably in a blood vessel. The device (2) comprises a joined sensor (70) for monitoring one or more physiological parameter for diagnostic or therapeutic purposes. Data access is assured by a passive RF transponder, in communication with an external read-out unit or an implanted device, providing as well to the energy supply of the sensor (70). The shape of the device of the invention (2) allows repositioning and retrieval by micro invasive methods, by means of a link section (20) coupleable with a grabbing device (45) mounted on a catheter (40).

WO 2004/110263 A1

Instrumented Retrievable Implantable Device

This patent application claims priority from European Patent Application EP03101769.2, filed on June 17, 2003, which is hereby incorporated by reference.

Field of the invention

- 5 The present invention deals with an implantable device, comprising a removable part, for retrievably securing the device inside a body lumen, and a sensor, for measuring, logging and/or transmitting relevant body parameters.

Description of related art

- 10 Implantable devices have long been applied, in particular in conjunction with balloon angioplasty, to restore proper flow in constricted blood vessels. In this application the blood vessel is expanded with an inflatable balloon, guided into the desired section of the vessel by means of a catheter. The intravascular device or stent is then positioned inside the
15 vessel to ensure that it maintains the enlarged diameter once the expanding balloon is removed.

- On the other hand it is known to use miniaturized devices for performing diagnostic or research measurement inside the body of a human or an animal. Such devices are in general inserted inside a blood
20 vessel or another body lumen by a suitable catheter. This procedure, even if it is only moderately invasive, must be performed in a medical establishment and does not allow prosecuting the measurement for an extended period of time or during patient's normal activities.

- Moreover the known stenting devices are in general suitable for
25 definitive implantation only. While safe and reliable procedures to position a stent into a body lumen are well established, this is not generally true for recovering or repositioning an already implanted device. Once a stent is

deployed its emplacement is considered definitive and recovering or replacing it would often require invasive surgery.

Brief summary of the invention

5 An aim of the present invention is to provide a practical and safe device for performing accurate inner measurements for diagnostic, research or therapy, without interfering with patient's normal activities and in a minimally invasive way.

10 Another object of the present invention is to provide a replaceable intravascular device, which can safely and easily be recovered from its position inside the body, or moved to a different position, without the necessity of invasive techniques.

15 These objects are attained by the devices and method of the independent claims in the corresponding categories, while the remaining claims deal with preferred and alternatives embodiment and examples. In particular said objects are attained by an implantable device, for placement in a body lumen, preferably in a blood vessel, comprising:

20 an expandable section having a variable dimension, said variable dimension allowing a compressed value D_c for delivery to said body lumen and an expanded value D_e , larger than said compressed value D_c , for implantation in said body lumen ;

a link section at one end of said device, comprising a grip, for joining said device to a catheter , and for applying an axial force on said device ;

25 at least one sensor permanently joined to said device ;
wherein said device is arranged for reacting to an axial pulling force to said grip, by assuming said compressed value of said variable dimension, for retrieval or repositioning of said implantable device ;
and by an apparatus for positioning an implantable device according to claim 1, comprising:

30 a flexible catheter, inserted into a flexible sleeve;
a grasp section, fixed to the tip of said catheter, for cooperating with

said link section of said implantable device, said clasp section comprising at least two opposed flexible fingers;

said flexible sleeve interacting with said flexible fingers for opening and closing them on said link section, and interacting with said expandable
5 section for reducing said variable dimension of said implantable device.

Brief Description of the Drawings

The invention will be better comprised from the study of the following description and claims and with reference to the appended figures wherein:

- 10 - figure 1 shows an implantable device according to the invention, connected to a delivery/recovery apparatus according to the invention;
- figures 2a to 2d represent a sequence of actions describing the use of the device and the apparatus of figure 1.
- figure 3 represent an alternative embodiment of the implantable device
15 according to the invention, comprising a flexible tether.
- figure 4a and 4b show another embodiment of the invention wherein the implantable device comprises a tubular mesh;
- figures 5 and 6 illustrate two different fashions of realizing the
20 connexion between the implantable device and the positioning apparatus of the invention;
- figures 7, 8, 9, 10 and 11 shows other embodiments of the implantable device according to the invention;
- figure 12 shows an application of the device of the invention in conjunction with a vascular stent.

- figure 13 shows an implantable device according to the invention and comprising a vascular filter.

Detailed Description of the Invention

According to a first embodiment of the present invention, the
5 implantable device 2 comprises a core 10, of elongated shape, on which are
disposed at least a plurality of elastic struts 6 which can assume all the
positions between the fully released configuration visible in figure 1, in
which the struts 6 extend radially from the body 10, and a compressed
configuration, in which the struts are almost in full contact with the core
10 10.

The transversal diameter of the device 2 is therefore variable
according to the configuration of the flexible struts 6. In their fully released
position the struts 6 define the maximum expanded diameter D_e of the
device, while the compressed diameter D_c is obtained when the struts 6 are
15 in full contact with the core 10.

In this particular example of the invention the struts 6 are in
number of 8, and disposed, as shown on figure 1, in two levels, each
comprising four radial struts. The skilled person will understand however
that the number of struts and their disposition could easily be modified,
20 according to the circumstances and the destination of the implantable
device 2.

The link section 20 is located at one extremity of the core 10, and
its function is to allow repeatable engagement and connection with the
grasp section placed on the delivery/recovery apparatus 3, also visible on
25 figure 1. The link section comprises, in this embodiment of the invention, a
round/cylindrical head 21, joined to the core by a relatively narrow neck 22.

The delivery/recovery apparatus 3 comprises a flexible catheter
40, enclosed in a flexible sleeve 35. On the tip of the catheter 40 is fixed a
grasping device composed by the four flexible fingers 45. According to the

relative position of the catheter 40 in the sleeve 45 the fingers can be retracted inside the sleeve 45, in which case they assume the closed configuration represented in figure 1, or they can extend forward from the sleeve 45, in which case their elasticity forces them in the open configuration shown on figure 2c.

The functioning of the implantable device 2 and of the apparatus 3 will now be explained in relation with figures 2a – 2d, showing a typical implantation sequence.

In figure 2a is visible the implantable device 2, connected to the catheter 40 by the fingers 45 closed on the neck 22 of the link section. The device 2 is fully retracted inside the sleeve 35.

In this configuration the sleeve 35 is inserted into the human or animal body, and guided until the tip of the apparatus 3, now containing the device 2, is at the place chosen for the implantation. The progress of the device into the body can for example be monitored and followed using conventional X-ray techniques. To this effect the device 2 and the delivery/recovery apparatus 3 may be equipped with radio-opaque marks.

Once the position of the device 2 is satisfactory, the operator retracts the sleeve 35 (fig. 2b). The device 2 is still connected and axially maintained by the catheter 40. In this way the struts 6, now free from the sleeve 35, open themselves and anchor the device 2 inside the blood vessel 3.

By continuing the retraction of the sleeve 35 the fingers 45 finally get free, and open themselves (fig, 2c). The device 2 is now detached from the catheter 40.

Finally the catheter 35 is pulled back, and the fingers 45 retracted inside the sleeve 35. In this configuration the apparatus 3 can be extracted from the body, leaving the implantable device 2 in place in the body lumen 8.

A recovery sequence involves all the above steps in reverse order. Initially the delivery/recovery apparatus 3 is inserted in the body lumen 8, with the grasp section fully retracted inside the sleeve 35 (Fig. 2d). The catheter 45 is then pushed out of the sleeve 35 in order to expose and open the fingers 45 (Fig. 2c). During this phase the fingers 45 touch the walls of the body lumen 8, and align the tip the catheter 35 with the axis of the body lumen, simplifying the connection between delivery/recovery apparatus 3 and the implantable device 2. Once the tip of the catheter 35 is in contact with the link section of the implantable device, the sleeve 35 is advanced (fig. 2b), in order to close the fingers 45 on the neck 22, thereby locking and aligning the catheter 35 and the implantable device 2. Finally the edge of the sleeve 35 enters in contact with the struts 6 and forces them in the compressed configuration. The device 2 is now released from the lumen 8 and can be recovered inside the sleeve 35.

The grasp section of the delivery/recovery apparatus 3 can of course take also other forms, different from the hook-shaped fingers of figure 1. In a variant of the present embodiment represented on figure 5, the grasp section comprises two rectangular or oval loops 49.

The link section 20 of the device 2 can also take other forms than the round head of figure 1. For example, in the variant of figure 6, which will be explained in more detail later, the head 21 has the shape of a ball. In the example visible on figure 8 the link section comprises a wire loop 221.

The present invention is however not limited to the shapes described here by way of example for the join section of the device 2 and the grasp section of the delivery/recovery apparatus 3, but comprises as well all the many different shapes adapted to interoperate together for the realization of the invention.

The device 2 further comprises at least a permanently attached sensor 70. For example the sensor 70 may measure a physical property, like blood pressure sensor, fluid flow, temperature or electric heart or muscle

activity. The sensor 70 may also record a chemical blood parameter, like pH, glycaemia, electrolytes or gas concentration.

Preferably the sensor 70 communicates with an external readout unit (not shown) via a wireless connection. In this way the parameters
5 acquired by the sensor 70 can be accessed whenever necessary, or automatically logged on a periodical basis in the readout unit for later analysis.

If requested, the readout unit may be arranged to trigger an
10 alarm signal in case an abnormal situation, calling for urgent medical care is detected.

Advantageously the wireless link between the external readout unit and the sensor 70 could also provide the necessary energy source for the sensor operation. The link could for example comprise a backscattering passive transponder.

15 In this variant of the invention, the sensor 70 is only active when the readout unit sends an electromagnetic flux toward the implanted device 2. In this case the electrical signal picked up by the transponder antenna serves, after rectification and conversion, to supply the sensor 70. The requested measurement is then sent back to the readout unit by
20 backscattering modulation or other transmission techniques.

Other wireless communication techniques, like for example HF, acousto-magnetic, electromagnetic, swept-RF or Macro-wave or others are also possible and comprised in the present invention.

By using a passive transponder, the need of an energy source in
25 the implantable device is avoided, thus reducing the size of the device 2 and the hazard connected with electrochemical batteries. Autonomous energy sources may however also be employed, according to the circumstances.

In an alternative, not represented, variant of the present invention, the data recorded by the sensor 70 are logged in a permanent memory included in the implantable device 2. In this case no real-time telemetry link is required. Instead the data are analyzed in a second
5 moment, when the implantable device 2 is removed from the patient's body.

According to this variant embodiment of the invention, the implantable device 2 may comprise an autonomous source of electrical energy, for example an electrochemical battery. Alternately, the
10 implantable device 2 may be alimented by an external source, via a magnetic link or another wireless energy transmission technique.

Advantageously, the sensor 70 may communicate with another implanted device present in the patient's body, via a wireless connection. Thanks to this communication, an implantable device may adapt its
15 operating parameters depending on data received from the sensor 70. Such implantable device may include for example a cardiac stimulator, a drug delivery device, or any other device. The data transmitted via the wireless link by the sensor 70 to the implantable device may be representative of any significant body parameter like for example blood or fluid pressure,
20 sugar concentration, or any other significant clinical parameter.

Advantageously the device of the invention comprises also a radiofrequency antenna for the wireless connection. According to circumstances the antenna may be incorporated in the device body or
comprise for example a flexible wire protruding from the device body, a
25 mesh antenna, a linear antenna or others.

According to another embodiment of the present invention, represented on figure 3, the sensor 70 is not rigidly joined to the device 2, but rather connected to it by a flexible tether 50.

This embodiment of the invention allows monitoring of body
30 parameters in places that, due to their conformation or for other reason,

would not be suitable for directly placing a device. An example of application for this embodiment of the present invention would be the monitoring of blood pressure in an aneurism

According to another embodiment of the present invention not represented in the figures, the device 2 includes a reservoir of a biologically active substance, which can be selectively put in fluid contact with the body lumen 8 by an appropriate command from an external unit in wireless communication with the implantable device 2. This embodiment of the invention comprises a hollow reservoir and an electrically actionable valve realized with known micro-fluidic and MEMS (microelectromechanical systems) techniques, for example by 2D or 3D photolithography, or by a LIGA process.

In another variant embodiment the device may contain elements loaded with a biologically active substance, which is passively released in the body, until the device is extracted, or the supply is used up.

According to the embodiment of the invention represented on figures 4a and 4b, the body of the implantable device 2 comprises a tubular elastic mesh 150 of biocompatible wire. The tubular mesh 150 has an expanded configuration, allowing it to adhere closely to the inner walls of the blood vessel 8, yet is sufficiently elastic to be compressed inside the sleeve 35 of the delivery/recovery apparatus 3. The link section consists, in this embodiment of the present invention, of a ball 21, connected to the mesh 150 by at least one wire 220, as it is visible on figure 6.

According to another embodiment of the present invention represented on figure 7, the device 2 comprises a plurality of curved smooth membranes 170 joined together by a common central edge 175. The outer edges 172 of the membranes 170 lie, in the deployed extended configuration, on the inner walls of the blood vessel 8, thereby securing the device 2 in place. To recover the device 2 the membranes 170 are bent elastically and / or rolled one on each other, by the combined action of the catheter 35 pulling on the ball 21 and of the edge of the sleeve 35 pushing

on the wires 220, until the device 2 is fully retracted inside the sleeve 35. In this particular embodiment, the exposed surfaces are smooth and parallel to the fluid current, thereby opposing a low flow resistance, without disturbing laminar flow.

5 According to another embodiment of the present invention represented on figure 9, the device 2 comprises two flexible lateral plates 160, having a cylindrical surface, joined by the triangular or conical flexible surfaces 163. In the expanded state the lateral surfaces 160 contact the inner wall of the body lumen 8 and maintain the device in the desired
10 position. The creases between lateral plates 160 and the connecting surfaces 163 can bend, compressing the device 2 inside the sleeve 35, as in the other embodiments.

 According to another embodiment of the present invention represented on figure 10, the device 2 comprises an elongated core 10 and
15 at least one flexible wire 180 comprising straight and bent sections, whose flexibility allows a compressed configuration for fitting inside the sleeve 35 and an expanded configuration for anchoring inside the body lumen 3 having a lateral dimension larger than the lateral dimension of said compressed configuration.

20 Figures 11 represents a further embodiment of the present invention, in which the implantable device comprises two flexible arms 66, joined as to form a flexible "U", and the join section fixed on the curved section of the "U"

 Figure 12 shows an application of the present invention in which
25 the implantable device 2 is inserted in a permanent or semipermanent angioplasty stent 15. In this case the particular embodiment of figure 11 is shown, inside a tubular stent 15. The skilled person will understand, however, that all presented embodiment of the invention may be adapted for use in this manner. In this particular application, the device of the
30 invention can for example be placed for a limited time, after an angioplasty operation, in the expanded body vessel. Thanks to this aspect of the

invention it is possible to monitor or log blood pressure, flow constriction, or other clinical parameters, or deliver drugs *in situ*.

Independently from the expansive action of the stent 15, it may be desirable in certain cases to provide for an interface element 15
5 between the implantable device 2 and the walls of the body lumen into which the device 2 is placed. The interface element 15 may include for example a cylindrical sleeve as represented on figure 12, optionally treated with appropriate substances for preventing or limiting a tissue growth at the implant site, thereby reducing the risk of embolism during the recovery
10 of the device 2.

The interface element 15 may be recovered with the device 2, or may be left *in situ* permanently or until a later moment. Other forms of interface elements are however possible and readily devisable by the skilled in the art.

15 A further embodiment of the present invention is now described with reference to figure 13. According to this embodiment the implantable device 2 comprises an embolism protection device 310.

During the positioning or recovery of the device of the invention, there is a risk that emboli dislodged by the procedure will migrate through
20 the circulatory system and cause infarction, strokes or other medical conditions. Similarly dangerous conditions may arise while the device is implanted in the foreseen location, according to the circumstances.

The protection device 310 prevents emboli from migrating through the circulatory system and may consist in a filtering device, capable
25 of capturing eventual embolic particles, while allowing essentially unimpeded blood flow. An example of such vascular filters is described, among others, in International Patent Application WO03/011185, which is hereby incorporated by reference. Many other filters means are however possible and comprised in the scope of the present invention. Other
30 devices, like for example balloons or other occlusion means are also

enclosed in the scope of the present invention. According to the necessity, the protection device can be positioned distally or proximally with reference to the device body 10.

One advantage of the present invention is that the implantable device 2 is releasably connected to a positioning apparatus for permanent or semipermanent delivery within a body lumen. It is however to be understood that the implantable device of the invention can as well be employed, if required or convenient, while still connected to the positioning apparatus 3. For example during the positioning or retrieval phases, or when a temporary diagnostic or therapeutic action is required.

The implantable device 2 of the invention may further provide an attachment site for connecting a removable part thereto. The removable part may include for example a drug-release element, which need to be renewed after a certain time, or comprise the sensor 70, or also comprise additional sensors or other diagnostic or clinical devices which can be connected to the implantable device 4 and removed at will by appropriate endoscopic or surgical techniques.

The attachment site may comprise any suitable attachment means, for connecting the removable part and the sensor. For example said attachment means may comprise a threaded connection or a clip connection, or others.

The present invention has been described by means of specific examples and embodiments. It will be understood however, by the skilled of the art, that various alternatives may be used and equivalents may be substituted for elements described herein, without deviating from the scope of the invention. Modifications may be necessary to adapt the invention to a particular situation or to particular materials or sensors without departing from the scope of the invention. It is intended that the invention not be limited to the embodiment presented herein by way of the example, but that the claims be given their broadest interpretation to cover all the embodiments, literal or equivalent, discussed herein.

Claims

1. Implantable device (2), for placement in a body lumen, preferably in a blood vessel (8), comprising:
 - an expandable section having a variable dimension, said variable dimension allowing a compressed value (D_c) for delivery to said
 - 5 body lumen (8) and an expanded value (D_e), larger than said compressed value (D_c), for implantation in said body lumen (8);
 - a link section (20), at one end of said device (2) comprising a grip (21, 221), for joining said device (2) to a catheter (40), and for
 - applying an axial force on said device (2);
 - 10 at least one sensor (70) joined to said device (2);
 - wherein said device (2) is arranged for reacting to an axial pulling force to said grip (21, 221), by assuming said compressed value (D_c) of said variable dimension, for retrieval or repositioning of at least part of said implantable device (2).
- 15 2. Implantable device according to claim 1, wherein said sensor (70) is permanently joined to said device (2).
3. Implantable device according to claim 1, comprising an attachment site, for connecting a removable part thereto.
4. Implantable device according to claim 1, comprising an
- 20 elongated core (10) and a plurality of elastic struts (6) having a released configuration, in which said elastic struts (6) radially protrude from said elongated core (10), and a compressed position, in which said elastic struts (6) are closer to said elongated core (10).
5. Implantable device according to claim 1, comprising a tubular
- 25 mesh of elastic wire, whose diameter allows a compressed value (D_c) and an expanded value (D_e), larger than said compressed value (D_c).
6. Implantable device according to claim 1, comprising a plurality of curved smooth membranes (170), parallel to the main axis of said device

(2), allowing essentially unobstructed fluid flow through said body lumen (8).

7. Implantable device according to claim 1, comprising a plurality of flexible lateral surfaces (160), for anchoring said device within said body lumen (8), bendably joined by a plurality of radial connection elements (163) allowing a compressed configuration having a lateral dimension (D_c) and an expanded configuration having a lateral dimension (D_e), larger than said lateral dimension (D_c) of said compressed configuration.

8. Implantable device according to claim 1, comprising an elongated core (10) and at least one flexible wire (180) comprising straight and bent sections, whose flexibility allows a compressed configuration having a lateral dimension (D_c) and an expanded configuration having a lateral dimension (D_e), larger than said lateral dimension (D_c) of said compressed configuration.

9. Implantable device according to one of the claims from 1 to 8, wherein at least a part of said sensor (70) is flexibly connected to said device, by a flexible tether (50).

10. Implantable device according to one of the claims from 1 to 9, wherein said sensor (70), includes a communication device to communicate with an external readout unit and/or to communicate with another implanted device by a wireless link.

11. Implantable device according to claim 10, wherein said wireless link also provides energy supply for said sensor (70).

12. Implantable device according to claim 10, further comprising a reservoir, which can selectively be put in fluid communication with said body lumen upon a command received on said wireless link.

13. Implantable device according to one of the claims 1 and 10, further comprising at least one release means, for releasing at least one substance comprised in said release means.

14. Implantable device according to one of the claims from 1 to 8,
5 wherein said grip (21, 221) comprises a head (21) having a transversal dimension, and a neck (22) connecting said head (21) to said device (2), having a dimension smaller than said transversal dimension of said head (21).

15. Implantable device according to one of the claims from 1 to 8,
10 wherein said grip (21, 221) is connected to said device (2) by at least one wire (220).

16. Implantable device according to one of the claims from 1 to 8, wherein said grip comprises a loop of wire (221).

17. Implantable device according to one of the claims from 1 to
15 16, further comprising an embolic protection device (310).

18. Implantable device according to claim 17, wherein said embolic protection device comprises filter means for retaining embolic particles.

19. Implantable device according to one of the claims from 1 to
20 16, wherein said sensor comprises at least one of: a temperature sensor; a pressure sensor; a chemical sensor, a fluid flow sensor, an ECG sensor, a pH sensor, an electrolyte sensor, a wireless communication device.

20. Apparatus (3) for positioning an implantable device (2) according to claim 1, comprising:
25 a flexible catheter (40), inserted into a flexible sleeve (35);
a grasp section, fixed to the tip of said catheter (40), for cooperating with said link section (20) of said implantable device (2), said grasp section comprising at least two opposed flexible fingers (45);

said flexible sleeve (35) interacting with said flexible fingers (45) for opening and closing them on said link section (20) of said implantable device (2), and interacting with an expandable section of said implantable device (2) for reducing a variable dimension of said
5 implantable device (2).

21. A combination of: an implantable device (2), for placement in a body lumen, and an apparatus (3) for positioning said implantable device (2),

said implantable device (2) comprising:
10 an expandable section having a variable dimension, said variable dimension allowing a compressed value (D_c) for delivery to said body lumen (8) and an expanded value (D_e), larger than said compressed value (D_c), for implantation in said body lumen (8);
a link section (20), at one end of said device (2) comprising a
15 grip (21, 221), for joining said device (2) to a catheter (40), and for applying an axial force on said device (2);
at least a sensor (70) joined to said device (2);
said apparatus comprising:
a flexible catheter (40), inserted into a flexible sleeve (35);
20 a grasp section, fixed to the tip of said catheter (40), for cooperating with said link section (20) of said implantable device (2), said grasp section comprising at least two opposed flexible fingers (45);
said flexible sleeve (35) interacting with said flexible fingers (45) for opening and closing them on said link section (20);
25 wherein said flexible sleeve (35) interacts with said implantable device (2) by forcing it to assume said compressed value (D_c) of said variable dimension, when said device (2) is pulled by said flexible catheter (40) into said flexible sleeve (35).

22. Method for sensing a parameter within a body lumen,
30 comprising:
a step of delivering an implantable device (2) comprising a miniaturized sensor (70) in said body lumen;
a step of expanding said implantable device for anchoring it

in said body lumen;

a step of contactless reading the value measured by said miniaturized sensor (70);

a step of retrieving said implantable device (2);

5 23. Method according to claim 22, wherein said step of contactless reading comprises transmitting said value on a wireless link, said wireless link also providing energy for the functioning of said sensor (70).

24. Method according to claim 22 or claim 23, wherein said device is implanted within a stent (15) in said body lumen (8).

10 25. Method according to claim 22 or claim 23, wherein said implantable device (2) is an implantable device according to one of the claims from 1 to 19.

15 26. Method according to claim 22 or claim 23, wherein said steps of delivering and said step of retrieving are carried out with the apparatus of claim 20.

2/5

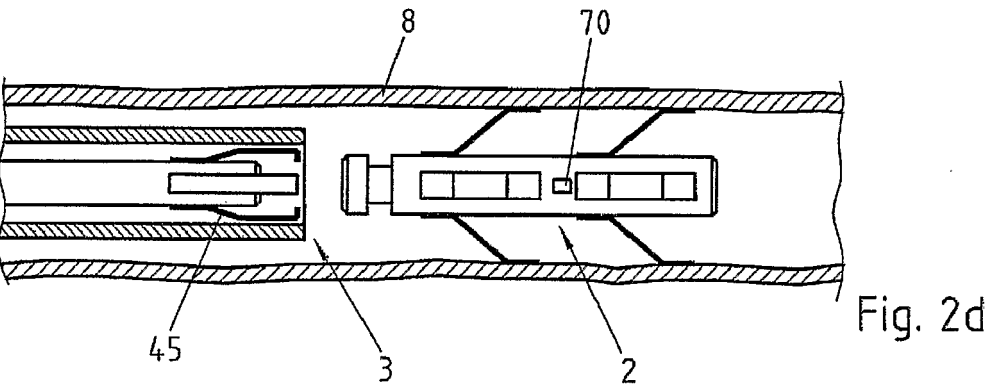
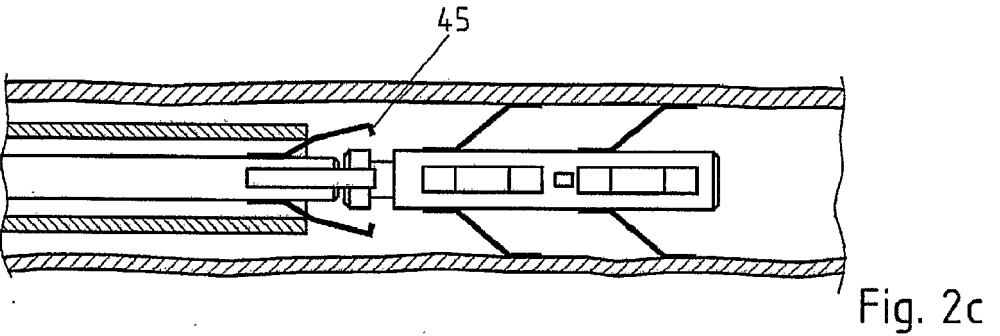
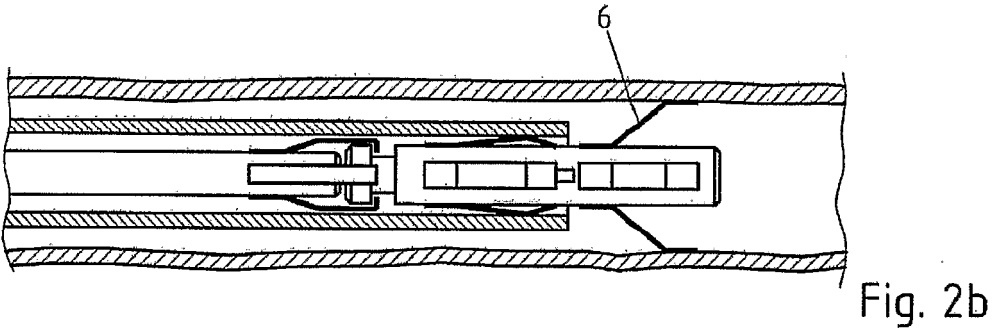
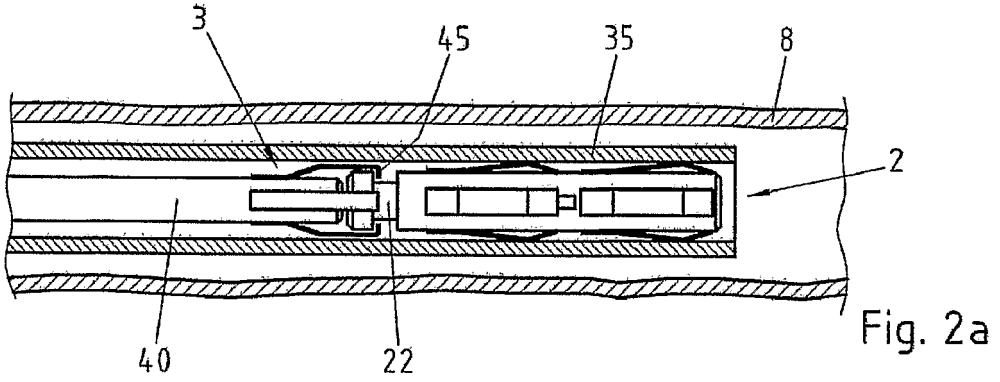

3/5

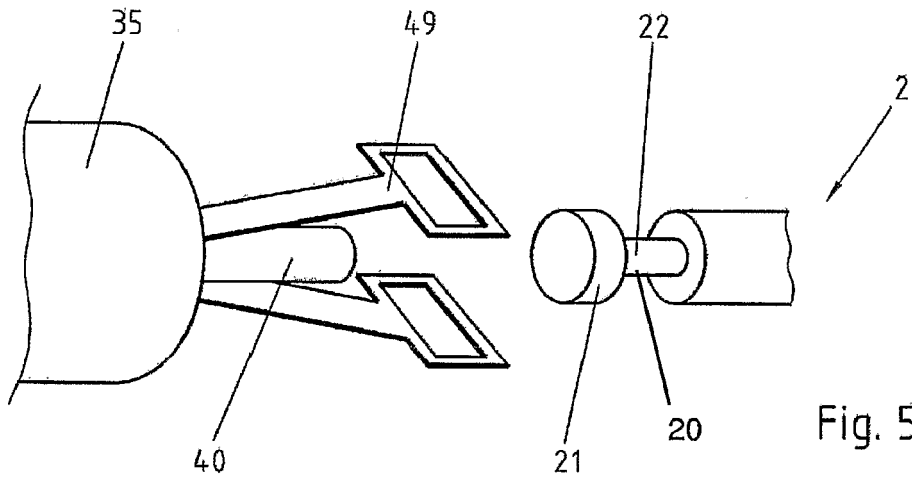

Fig. 5

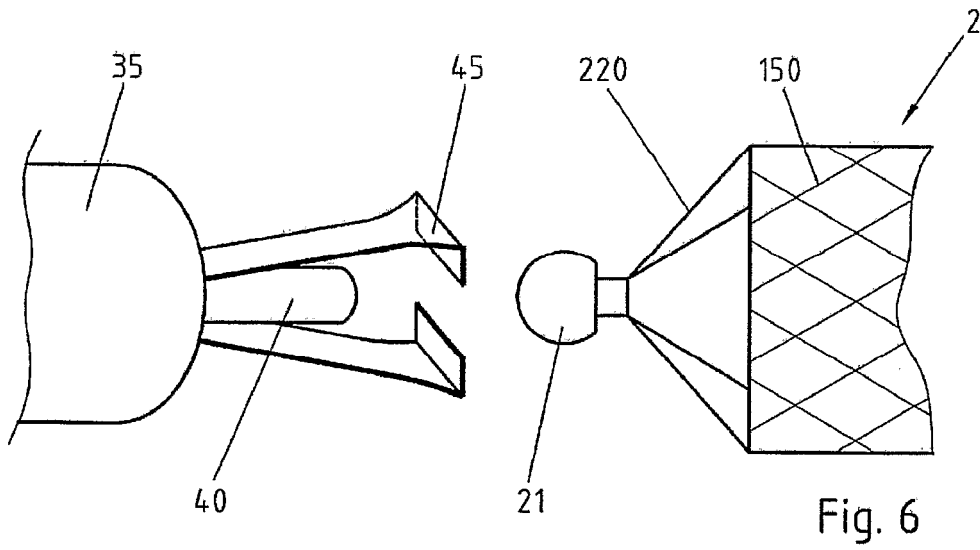

Fig. 6

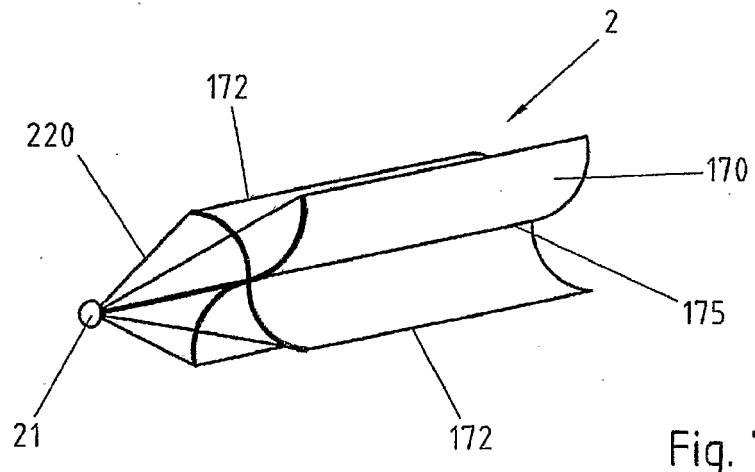

Fig. 7

4/5

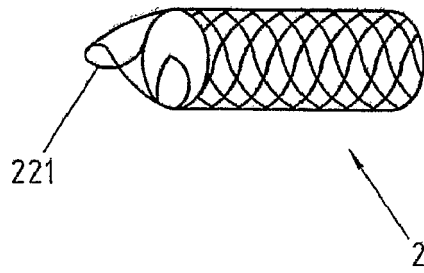

Fig. 8

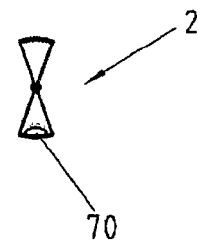
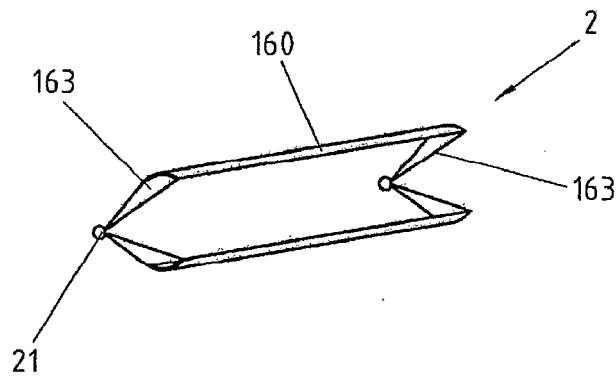

Fig. 9

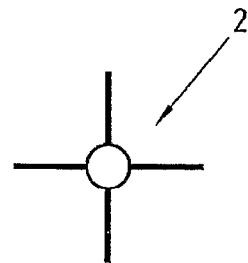
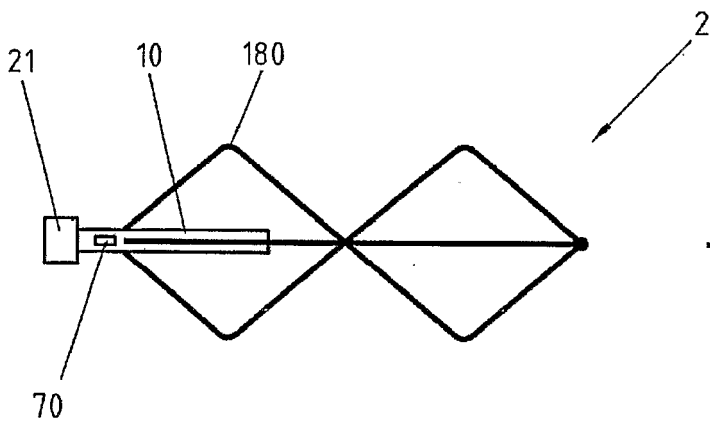

Fig. 10

5/5

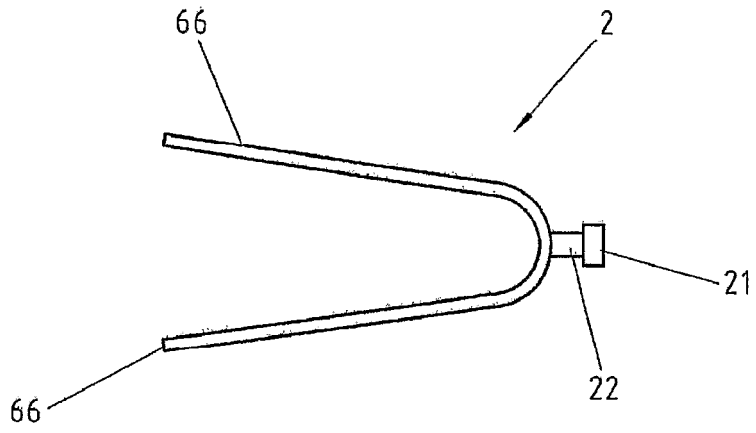

Fig. 11

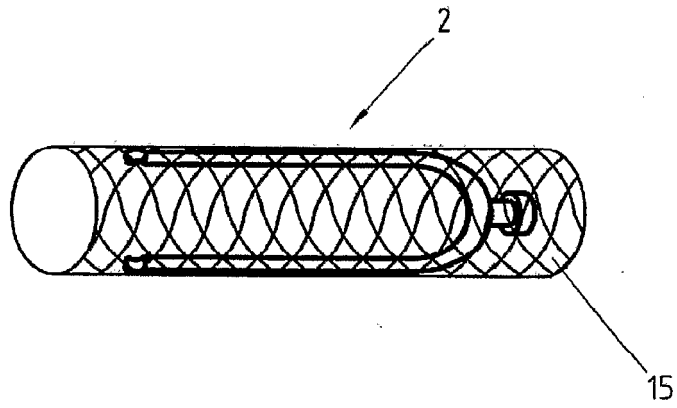

Fig. 12

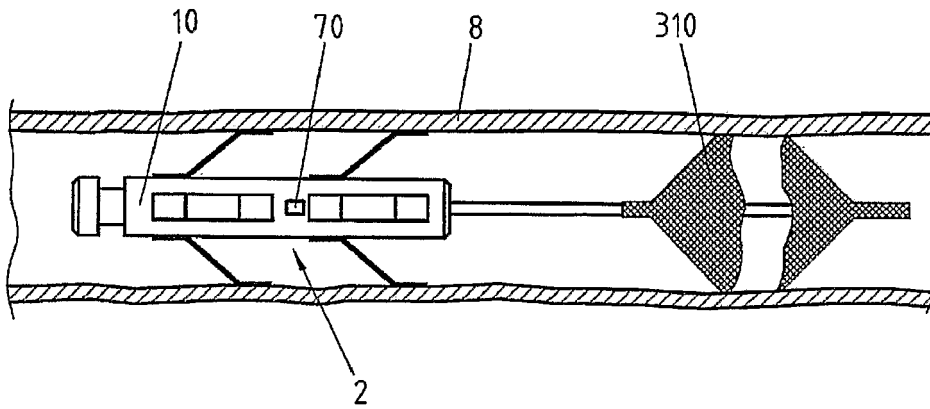

Fig. 13

INTERNATIONAL SEARCH REPORT

International Application No
PCT/EP2004/051121

A. CLASSIFICATION OF SUBJECT MATTER IPC 7 A61B5/00				
According to International Patent Classification (IPC) or to both national classification and IPC				
B. FIELDS SEARCHED				
Minimum documentation searched (classification system followed by classification symbols) IPC 7 A61B				
Documentation searched other than minimum documentation to the extent that such documents are included in the fields searched				
Electronic data base consulted during the international search (name of data base and, where practical, search terms used) EPO-Internal, WPI Data, PAJ				
C. DOCUMENTS CONSIDERED TO BE RELEVANT				
Category °	Citation of document, with indication, where appropriate, of the relevant passages	Relevant to claim No.		
X A	US 4 886 065 A (COLLINS JR EARL R) 12 December 1989 (1989-12-12) the whole document	1, 9, 14, 20, 21 2-8, 10-13, 15-19		
A	----- US 6 442 413 B1 (SILVER JAMES H) 27 August 2002 (2002-08-27) column 19, line 29 - line 63; figure 7	1-21		
A	----- US 5 954 761 A (MACHEK JAMES E ET AL) 21 September 1999 (1999-09-21) claim 23; figures 7-10 -----	1-21		
<input type="checkbox"/> Further documents are listed in the continuation of box C.				
<input checked="" type="checkbox"/> Patent family members are listed in annex.				
° Special categories of cited documents :				
<table style="width: 100%; border: none;"> <tr> <td style="width: 50%; border: none; vertical-align: top;"> *A* document defining the general state of the art which is not considered to be of particular relevance *E* earlier document but published on or after the international filing date *L* document which may throw doubts on priority claim(s) or which is cited to establish the publication date of another citation or other special reason (as specified) *O* document referring to an oral disclosure, use, exhibition or other means *P* document published prior to the international filing date but later than the priority date claimed </td> <td style="width: 50%; border: none; vertical-align: top;"> *T* later document published after the international filing date or priority date and not in conflict with the application but cited to understand the principle or theory underlying the invention *X* document of particular relevance; the claimed invention cannot be considered novel or cannot be considered to involve an inventive step when the document is taken alone *Y* document of particular relevance; the claimed invention cannot be considered to involve an inventive step when the document is combined with one or more other such documents, such combination being obvious to a person skilled in the art. *&* document member of the same patent family </td> </tr> </table>			*A* document defining the general state of the art which is not considered to be of particular relevance *E* earlier document but published on or after the international filing date *L* document which may throw doubts on priority claim(s) or which is cited to establish the publication date of another citation or other special reason (as specified) *O* document referring to an oral disclosure, use, exhibition or other means *P* document published prior to the international filing date but later than the priority date claimed	*T* later document published after the international filing date or priority date and not in conflict with the application but cited to understand the principle or theory underlying the invention *X* document of particular relevance; the claimed invention cannot be considered novel or cannot be considered to involve an inventive step when the document is taken alone *Y* document of particular relevance; the claimed invention cannot be considered to involve an inventive step when the document is combined with one or more other such documents, such combination being obvious to a person skilled in the art. *&* document member of the same patent family
A document defining the general state of the art which is not considered to be of particular relevance *E* earlier document but published on or after the international filing date *L* document which may throw doubts on priority claim(s) or which is cited to establish the publication date of another citation or other special reason (as specified) *O* document referring to an oral disclosure, use, exhibition or other means *P* document published prior to the international filing date but later than the priority date claimed	*T* later document published after the international filing date or priority date and not in conflict with the application but cited to understand the principle or theory underlying the invention *X* document of particular relevance; the claimed invention cannot be considered novel or cannot be considered to involve an inventive step when the document is taken alone *Y* document of particular relevance; the claimed invention cannot be considered to involve an inventive step when the document is combined with one or more other such documents, such combination being obvious to a person skilled in the art. *&* document member of the same patent family			
Date of the actual completion of the international search <p style="text-align: center;">2 November 2004</p>	Date of mailing of the international search report <p style="text-align: center;">10/11/2004</p>			
Name and mailing address of the ISA European Patent Office, P.B. 5818 Patentlaan 2 NL - 2280 HV Rijswijk Tel. (+31-70) 340-2040, Tx. 31 651 epo nl, Fax: (+31-70) 340-3016	Authorized officer <p style="text-align: center;">Mausser, T</p>			

INTERNATIONAL SEARCH REPORT

International application No.
PCT/EP2004/051121

Box II Observations where certain claims were found unsearchable (Continuation of item 2 of first sheet)

This International Search Report has not been established in respect of certain claims under Article 17(2)(a) for the following reasons:

1. Claims Nos.: 22-26
because they relate to subject matter not required to be searched by this Authority, namely:
Rule 39.1(iv) PCT - Method for treatment of the human or animal body by surgery
2. Claims Nos.:
because they relate to parts of the International Application that do not comply with the prescribed requirements to such an extent that no meaningful International Search can be carried out, specifically:
3. Claims Nos.:
because they are dependent claims and are not drafted in accordance with the second and third sentences of Rule 6.4(a).

Box III Observations where unity of invention is lacking (Continuation of item 3 of first sheet)

This International Searching Authority found multiple inventions in this International application, as follows:

1. As all required additional search fees were timely paid by the applicant, this International Search Report covers all searchable claims.
2. As all searchable claims could be searched without effort justifying an additional fee, this Authority did not invite payment of any additional fee.
3. As only some of the required additional search fees were timely paid by the applicant, this International Search Report covers only those claims for which fees were paid, specifically claims Nos.:
4. No required additional search fees were timely paid by the applicant. Consequently, this International Search Report is restricted to the invention first mentioned in the claims; it is covered by claims Nos.:

Remark on Protest

- The additional search fees were accompanied by the applicant's protest.
- No protest accompanied the payment of additional search fees.

INTERNATIONAL SEARCH REPORT

Information on patent family members

International Application No PCT/EP2004/051121
--

Patent document cited in search report	Publication date	Publication date	Patent family member(s)	Publication date
US 4886065	A	12-12-1989	NONE	
US 6442413	B1	27-08-2002	AU 5965601 A	26-11-2001
			WO 0187137 A2	22-11-2001
			US 2002128546 A1	12-09-2002
			US 2003009093 A1	09-01-2003
			US 2003114735 A1	19-06-2003
			US 2004176672 A1	09-09-2004
US 5954761	A	21-09-1999	CA 2284830 A1	01-10-1998
			EP 0968028 A1	05-01-2000
			JP 2001517995 T	09-10-2001
			WO 9842403 A1	01-10-1998

专利名称(译)	仪器可检索的可植入装置		
公开(公告)号	EP1633242A1	公开(公告)日	2006-03-15
申请号	EP2004741806	申请日	2004-06-15
[标]申请(专利权)人(译)	MOSER RAYMOND		
申请(专利权)人(译)	MOSER , RAYMOND		
当前申请(专利权)人(译)	MOSER , RAYMOND		
[标]发明人	MOSER RAYMOND		
发明人	MOSER, RAYMOND		
IPC分类号	A61B5/00 A61B5/0215 A61B5/042 A61B5/07		
CPC分类号	A61B5/6876 A61B5/0215 A61B5/042 A61B5/076 A61B5/14546 A61B5/4839 A61B5/6862 A61B5/6886		
优先权	2003101769 2003-06-17 EP		
其他公开文献	EP1633242B1		
外部链接	Espacenet		

摘要(译)

仪器化可回收植入装置 (2) , 包括可扩张部分 , 用于放置在体腔内 , 优选放置在血管中。装置 (2) 包括连接的传感器 (70) , 用于监测一个或多个生理参数以用于诊断或治疗目的。通过与外部读出单元或植入设备通信的无源RF应答器确保数据访问 , 同时提供传感器 (70) 的能量供应。本发明 (2) 的装置的形状允许通过微创方法重新定位和取回 , 借助于可与安装在导管 (40) 上的抓取装置 (45) 连接的连接部分 (20) 。