

(19) World Intellectual Property  
Organization  
International Bureau



(43) International Publication Date  
15 April 2004 (15.04.2004)

PCT

(10) International Publication Number  
WO 2004/030480 A1

- (51) International Patent Classification<sup>7</sup>: A41D 20/00 // A61B 5/00
- (21) International Application Number: PCT/US2003/031208
- (22) International Filing Date: 1 October 2003 (01.10.2003)
- (25) Filing Language: English
- (26) Publication Language: English
- (30) Priority Data: 60/415,468 1 October 2002 (01.10.2002) US
- (71) Applicant: NELLCOR PURITAN BENNETT INCORPORATED [US/US]; 4280 Hacienda Drive, Pleasanton, CA 94588 (US).
- (72) Inventors: HANNULA, Don; 1450 Andrews Street, San Luis Obispo, CA 93401 (US). COAKLEY, Joseph; 11732 Casa Linda Court, Dublin, CA 94568 (US).
- (74) Agents: KUSHA, Babak et al.; TOWNSEND AND TOWNSEND AND CREW LLP, Two Embarcadero Center, Eighth Floor, San Francisco, CA 94111 (US).
- (81) Designated States (*national*): CA, JP.
- (84) Designated States (*regional*): European patent (AT, BE, BG, CH, CY, CZ, DE, DK, EE, ES, FI, FR, GB, GR, HU, IE, IT, LU, MC, NL, PT, RO, SE, SI, SK, TR).
- Published:**  
— with international search report  
— before the expiration of the time limit for amending the claims and to be republished in the event of receipt of amendments
- For two-letter codes and other abbreviations, refer to the "Guidance Notes on Codes and Abbreviations" appearing at the beginning of each regular issue of the PCT Gazette.*

(54) Title: HEADBAND WITH TENSION INDICATOR

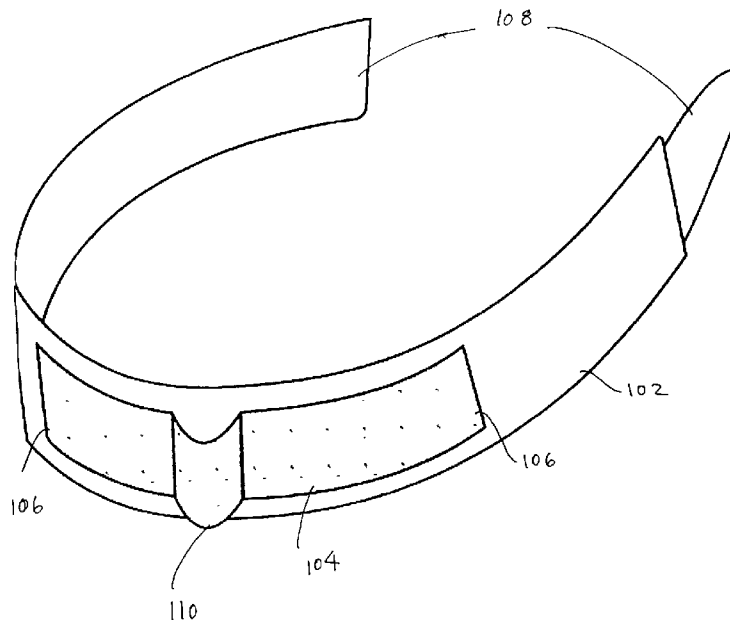

(57) Abstract: A headband (102) with a tension indicator (110) having an elastic segment (102) sized to fit around a wearer's head; and a non-elastic segment (104) being smaller than and attached with the elastic segment (102). The non-elastic segment (104) is sized to span a portion of the elastic segment (102) when the elastic segment (102) is stretched, and the non-elastic segment (104) is larger than the portion of the elastic segment (102) it spans when the elastic segment (102) is not stretched. The non-elastic segment (104) is attached with the elastic segment in such a manner that the non-elastic segment (104) projects out from the surface of the elastic portion when the headband is not sufficiently tight, thus creating a loop (110) which provides a visual indication that the headband needs re-tightening.

WO 2004/030480 A1

## HEADBAND WITH TENSION INDICATOR

### CROSS-REFERENCES TO RELATED APPLICATIONS

[0001] This application claims the benefit of U.S. Provisional Patent Application No. 60/415,468, filed October 1, 2002, which application is incorporated herein by reference in its entirety for all purposes.

### BACKGROUND OF THE INVENTION

[0002] The present invention relates to headbands, and in particular to headbands that have a tension indicator for indicating when a headband is appropriately stretched and is thus capable of imparting an appropriate level of pressure to a wearer's head.

[0003] Various headband devices are known. These include athletic type headband devices as well as more sophisticated headband devices, such as those used to mount devices carried on the head. Some headband devices are used to apply a certain level of pressure to the region under the headband. Such applied pressures are useful, for example, to support a medical sensor for the wearer of the headband. In such circumstances, there is a need for an improved headband having a tension indicator.

### BRIEF SUMMARY OF THE INVENTION

[0004] Embodiments of the present invention are directed to a head band with a tension indicator. In one embodiment, the present invention provides a headband having an elastic segment sized to fit around a wearer's head; and a non-elastic segment being smaller than and attached with the elastic segment. The non-elastic segment is sized to span a portion of the elastic segment when the elastic segment is stretched, and the non-elastic segment is larger than the portion of the elastic segment it spans when the elastic segment is not stretched.

[0005] In one aspect, the non-elastic segment is attached with the elastic segment in such a manner that the non-elastic segment projects out from the surface of the elastic portion when the headband is not sufficiently tight, thus creating a loop which provides a visual indication that the headband needs re-tightening.

[0006] In another aspect, the non-elastic segment is formed with a fold or a crease, which causes the non-elastic portion to project out from the surface of the elastic portion in a pronounced fashion as the elastic segment retracts.

[0007] In another aspect, the non-elastic segment is sized to not project out from the surface of the elastic portion when the headband is sufficiently tight, thus indicating an adequate level of tension corresponding with delivering a pressure in the range higher than the venous pressure and lower than the capillary pressure to the forehead of the wearer.

[0008] In an alternate embodiment, the present invention provides a headband having an inelastic segment sized to fit around a wearer's head; and an elastic segment that is smaller than and attached with the inelastic segment. The elastic segment is sized to span a portion of the inelastic segment when the elastic segment is stretched, and the elastic segment is smaller than the portion of the inelastic segment it spans when the elastic segment is not stretched.

[0009] For a further understanding of the nature and advantages of the invention, reference should be made to the following description taken in conjunction with the accompanying drawings.

#### BRIEF DESCRIPTION OF THE DRAWINGS

[0010] Fig. 1 is a diagram of a forehead oximetry sensor being applied to a patient.

[0011] Fig. 2 is a diagram of a forehead oximetry sensor being held to a patient's forehead with a headband.

[0012] Fig. 3 is a diagram of one embodiment of the headband in accordance with the present invention.

[0013] Fig. 4 is a diagram of an alternate embodiment of the headband in accordance with the present invention.

[0014] Fig. 4A is a top view detail diagram of the crease or fold of Fig. 4.

[0015] Fig. 5 is a front view diagram of an embodiment of the headband in accordance with the present invention shown worn by a user.

[0016] Fig. 6 is a top view diagram of an embodiment of the headband in accordance with the present invention shown in proper tension when worn by a user.

[0017] Fig. 7 is a top view diagram of an embodiment of the headband in accordance with the present invention shown in less than proper tension when worn by a user.

[0018] Fig. 8 is a diagram of an alternate embodiment of the headband in accordance with the present invention.

#### DETAILED DESCRIPTION OF THE INVENTION

[0019] The embodiments of the present invention are directed towards a headband with a tension indicator. Such a headband may be used to support the administration of a health care related service to a patient. Such a service may include the placement of a sensor 101 on a patient's forehead, such as for example, an oximetry sensor (e.g., those manufactured by Nellcor Puritan Bennett, the assignee herein), as is shown in Fig. 1. A typical pulse oximeter measures two physiological parameters, percent oxygen saturation of arterial blood hemoglobin ( $SpO_2$  or sat) and pulse rate. Oxygen saturation can be estimated using various techniques. In one common technique, the photocurrent generated by the photo-detector is conditioned and processed to determine the ratio of modulation ratios (ratio of ratios) of the red to infrared signals. This modulation ratio has been observed to correlate well to arterial oxygen saturation. The pulse oximeters and sensors are empirically calibrated by measuring the modulation ratio over a range of in vivo measured arterial oxygen saturations ( $SaO_2$ ) on a set of patients, healthy volunteers, or animals. The observed correlation is used in an inverse manner to estimate blood oxygen saturation ( $SpO_2$ ) based on the measured value of modulation ratios of a patient. The estimation of oxygen saturation using modulation ratios is described in U.S. Patent No. 5,853,364, entitled "METHOD AND APPARATUS FOR ESTIMATING PHYSIOLOGICAL PARAMETERS USING MODEL-BASED ADAPTIVE FILTERING", issued December 29, 1998, and U.S. Patent No. 4,911,167, entitled "METHOD AND APPARATUS FOR DETECTING OPTICAL PULSES", issued March 27, 1990, and the relationship between oxygen saturation and modulation ratio is further described in U.S. Patent No. 5,645,059, entitled "MEDICAL SENSOR WITH MODULATED ENCODING SCHEME," issued July 8, 1997, the disclosures of which are herein incorporated by reference in their entirety. Most pulse oximeters extract the plethysmographic signal having first determined saturation or pulse rate. An exemplary forehead oximetry sensor is described in a co-pending United States Patent Application No. 10/256,245, entitled: "Stacked Adhesive Optical Sensor," the disclosure of which is herein incorporated by reference in its entirety for all purposes.

[0020] The force applied to the oximetry sensor can be a factor in the proper functioning of the sensor. In certain clinical scenarios, a headband 200 is required to be used in conjunction with a forehead sensor 101 (e.g., an oximetry sensor), as is shown in Fig. 2. Fig. 2 shows the sensor leads extending from the sensor (not shown) outward from beneath the headband. Such clinical scenarios include scenarios where: patient is lying down with his/her head near or below chest level; patient is subject to elevated venous pressure; patient is diaphoretic; patient is moving excessively, such as during exercise; as well as other scenarios where venous pulsations can introduce errors in oximetry calculations. In those scenarios, without a headband, or force on the oximetry sensor, venous pulsations could cause an incorrect interpretation of the waveform, and therefore result in a less than accurate determination of the oxygen saturation and pulse rate values. The headband can be used to apply pressure to the oximetry sensor, thus reducing the effects of venous pulsations. When used to support an oximetry sensor, the amount of force applied by the sensor on the forehead should be greater than the venous pressure, but less than the arteriole pressure. Generally, a good pressure range is one where the applied pressure is higher than venous pressure (e.g., 3-5 mm Hg) and lower than the capillary pressure (e.g., 22 mm Hg). Preferably, this should be between 15 mm Hg and 20 mm Hg in the adult patient. The headband in accordance with the embodiments of the present invention may be adjusted for use with any size wearer by using an adjustable closure mechanism, such as for example a hook and loop closure mechanism. The user can apply a wide range of pressures to the forehead oximetry sensor depending on the amount of tension which has been applied to the headband during its placement around the wearer's head.

[0021] The embodiments of the present invention are intended to alleviate the guesswork by the caregivers by giving them a visual indicator of the proper amount of tension required in the headband during placement around the head. The required tension is related to the pressure being applied by the sensor when it is attached with the patient.

[0022] In one embodiment, shown in Fig. 3, an elastic headband 102 is shown in an unstretched position. A non-elastic fabric 104 is shown attached to the elastics portion 102 along two of its edges 106. The other two edges of the non-elastic portion are not attached to the elastic segment and are thus free to project outward away from the face of the elastic segment. The non-elastic segment is smaller the elastic segment. The non-elastic segment is sized to span a portion of the elastic segment when the elastic segment is stretched. The non-elastic segment is larger than the portion of the elastic segment it spans when the elastic segment is not stretched. As the elastic segment 102 is stretched from its

non-stretched position, the non-elastic portion is pulled at its edges 106 along with the stretching elastic segment 102 until the elastic portion between the edges has stretched to a length equal to the length of the non-elastic portion. The headband also includes closure mechanisms (not shown), which are described below in conjunction with Fig. 4. Fig. 5 shows a front view diagram of an embodiment of the headband in accordance with the present invention shown worn by a user. It is noted that the headband may be used to hold and impart a pressure against a sensor, such as an oximetry sensor applied to a patient's forehead, as shown in Fig. 2. For clarity in describing the tension indicator, such a sensor is not shown in Figs. 5-7. Fig. 6 is a top view diagram of an embodiment of the headband 102 in accordance with the present invention shown in proper tension when worn by a user. As is shown in this figure, when the headband is properly tightened, the pressure indicator portion 104 is pulled tight across the elastic portion 102, thus not providing a visual indication that the headband needs to be retightened. On the other hand, Fig. 7 shows a top view diagram of an embodiment of the headband in accordance with the present invention shown in less than proper tension when worn by a user. As is shown in Fig. 7, when a less than adequate pressure is being applied by the headband to a user's forehead, or when the headband is not tight enough, the indicator 104 projects out from the surface creating a loop which provides a visual cue that the headband needs retightening.

[0023] When the headband is not stretched there is an amount of slack between the non-elastic and elastic portions. When the headband is stretched, the slack in the non-elastic strap is eliminated, giving the visual indication that the headband stretch is sufficient. The headband is chosen to be long enough to fit around the head of a user (or patient). The elastic material may be made of any suitable fabric, such as an open cell urethane foam. The non-elastic strap, which is shorter than the elastic portion is sewn or attached otherwise (e.g., adhesively, etc.) onto the elastic headband at a spacing that is less than the lengths of the non-elastic portion. The non-elastic material may be made of any suitable fabric, such a Dacron-type fabric.

[0024] Fig. 4 is a diagram of an alternate embodiment of the headband in accordance with the present invention. An elastic headband 102 is shown in an unstretched position. A non-elastic fabric 104 is shown attached to the elastics portion 102 along two of its edges 106. The other two edges of the non-elastic portion are not attached to the elastic segment and are thus free to project outward away from the face of the elastic segment. The non-elastic segment 104 is smaller the elastic segment 102. The non-elastic segment is sized to span a portion of the elastic segment when the elastic segment is stretched. The non-

elastic segment is larger than the portion of the elastic segment it spans when the elastic segment is not stretched. As the elastic segment 102 is stretched from its non-stretched position, the non-elastic portion is pulled at its edges 106 along with the stretching elastic segment 102 until the elastic portion between the edges has stretched to a length equal to the length of the non-elastic portion.

[0025] Fig. 4 also shows the non-elastic portion to include a permanent crease or a fold 110. As shown in Fig. 4A, such a fold 110 may be made by overlapping the non-elastic portion to form a fold and then heat pressing or heat sealing the fabric to form a permanent fold or crease. In one embodiment, the fold or crease is made in the middle of the inelastic segment, which causes it to project outward in a sharp, angular fashion as the elastic band 102 retracts or relaxes. In operation, it has been shown that the sharp, angular crease or fold acts as a mechanical amplifier and provides a more distinct visual cue and better sensitivity as to when the threshold of minimal headband tension has been passed. The creased tension indicator 110 exhibits increased sensitivity to a loss in headband tension by projecting further away from the elastic band in a skewed fashion. The creased tension indicator 110 provides a more pronounced visual cue both from the perspective of looking directly at the forehead and from looking down at the top (edge) of the headband. The material chosen for the inelastic portion having a fold or a crease can be similar to the non-creased or non-folded inelastic material. In addition, a material such a polyester webbing material, which is capable of holding a fold or a crease, may also be used. The elastic material may be made of a material as is described above, or made using other suitable material such as a terry band.

[0026] When the headband is not stretched there is an amount of slack between the non-elastic and elastic portions. When the headband is stretched, the slack in the non-elastic strap is eliminated, giving the visual indication that the headband stretch is sufficient.

[0027] Also shown in Fig. 4, and applicable to the embodiment described in conjunction with Fig. 3, is the closure device 108. One such closure device is a hook and loop type closure. The headband in accordance with the embodiments of the present invention may use other closure mechanisms such as snaps, buttons, adhesives, pins, or combinations thereof, as well as others known to those of skill in the relevant arts. Alternately, the headband may be a pre-formed loop, without a separate closure mechanism.

[0028] The headband described above includes a sensor attachment pressure indicator. As described above, the headband may be used to allow a sensor's attachment

pressure with the patient's tissue location (e.g. forehead, and so on) to be chosen which is greater than venous pulsations (e.g., 5-10 mm Hg) but less than a maximum amount (e.g., 30 mm Hg, or so). As described above, such a pressure indicator is attached with the headband. Alternately, the pressure indicator may be attached with the sensor, such as an oximetry sensor. One embodiment of the pressure indicator is a tension indicator as described above with reference to Figs. 3-4. Other pressure indicating means include pressure or force sensors small and light enough to be included with either the sensor or the headband assembly.

[0029] The information provided by the pressure indicator may be used to help establish an acceptable windows of pressure for the sensor's attachment with a patient. The acceptable window of pressure may also be enhanced to include the affects of the patient's head elevation relative to the patient's heart.

[0030] Additionally, the concept of using a headband to ensure an acceptable sensor attachment pressure is extendible to other patient body locations; locations where a sensor attachment pressure can help provide a more accurate sensor reading.

[0031] An alternate embodiment of the tension or pressure indicating headband in accordance with the present invention is shown in Fig. 8. As is shown in Fig. 8, the headband includes an inelastic portion 604 and an elastic portion 602. The tension indicating portion 606 is also made of an inelastic material. The tension indicating portion 606 may be a creased or folded as described in conjunction with Fig. 4 or as is shown uncreased or unfolded as described in conjunction with Fig. 3. The description of the closure devices and how the elastic and inelastic portions are attached to one another are also set forth above. In this embodiment, the main stretchable portion is elastic portion 602. Once the headband has been stretched such that section 602 is stretched to match the length of section 606, the headband's stretch will be limited. This embodiment by having a shorter elastic portion limits the extension of the headband and hence limits the range of pressures that can be applied by the headband against a user's forehead or the sensor applied to a user's forehead.

[0032] As will be understood by those skilled in the art, the present invention may be embodied in other specific forms without departing from the essential characteristics thereof. These other embodiments are intended to be included within the scope of the present invention, which is set forth in the following claims.

WHAT IS CLAIMED IS:

1. A headband, comprising:  
an elastic segment sized to fit around a wearer's head; and  
a non-elastic segment being smaller than and attached with said elastic segment, said non-elastic segment sized to span a portion of said elastic segment when said elastic segment is stretched, said non-elastic segment being larger than said portion of said elastic segment it spans when said elastic segment is not stretched.
2. The headband of claim 1 further comprising a closure mechanism coupled with said elastic portion.
3. The headband of claim 2 wherein said closure mechanism is a hook and loop closure, a snap, a button, an adhesive, a pin, or combinations thereof.
4. The headband of claim 1 wherein said elastic segment is rectangular shaped having a long and a short dimension, and said non-elastic segment is attached along a set of its edges with said elastic segment, wherein said set of edges are generally parallel to said short dimension.
5. The headband of claim 1 wherein said non-elastic segment is attached with said elastic segment in such a manner that said non-elastic segment projects out from the surface of the elastic portion when said headband is not sufficiently tight, thus creating a loop which provides a visual indication that the headband needs re-tightening.
6. The headband of claim 1 wherein said non-elastic segment is formed with a fold or a crease, which causes said non-elastic portion to project out from the surface of the elastic portion in a pronounced fashion as the elastic segment retracts.
7. The headband of claim 5 wherein said non-elastic segment is sized to not project out from the surface of the elastic portion when said headband is sufficiently tight thus indicating an adequate level of tension corresponding with delivering a pressure in the range higher than the venous pressure and lower than the capillary pressure to the forehead of the wearer.
8. A headband, comprising:  
an inelastic segment sized to fit around a wearer's head; and

an elastic segment being smaller than and attached with said inelastic segment, said elastic segment sized to span a portion of said inelastic segment when said elastic segment is stretched, said elastic segment being smaller than said portion of said inelastic segment it spans when said elastic segment is not stretched.

9. The headband of claim 8 further comprising a closure mechanism coupled with said elastic portion.

10. The headband of claim 9 wherein said closure mechanism is a hook and loop closure, a snap, a button, an adhesive, a pin, or combinations thereof.

11. The headband of claim 8 wherein said inelastic segment is rectangular shaped having a long and a short dimension, and said elastic segment is attached along a set of its edges with said inelastic segment, wherein said set of edges are generally parallel to said short dimension.

12. The headband of claim 8 wherein said elastic segment is attached with said inelastic segment in such a manner that said non-elastic segment projects out from the surface adjacent to a user's forehead when said headband is not sufficiently tight, thus creating a loop which provides a visual indication that the headband needs re-tightening.

13. The headband of claim 12 wherein said non-elastic segment is sized to not project out from said surface when said headband is sufficiently tight thus indicating an adequate level of tension corresponding with delivering a pressure in the range higher than venous pressure and lower than capillary pressure to the wearer's forehead.

14. A headband for holding an oximetry sensor on the forehead of a patient, comprising:

an elastic segment sized to fit around a patient's head and over an oximetry sensor located on the forehead of a patient; and

a non-elastic segment being smaller than and attached with said elastic segment, said non-elastic segment sized to span a portion of said elastic segment when said elastic segment is stretched, said non-elastic segment being larger than said portion of said elastic segment it spans when said elastic segment is not stretched.

15. The headband of claim 14 further comprising a closure mechanism coupled with said elastic portion.

16. The headband of claim 15 wherein said closure mechanism is a hook and loop closure, a snap, a button, an adhesive, a pin, or combinations thereof.

17. The headband of claim 14 wherein said non-elastic segment is attached with said elastic segment in such a manner that said non-elastic segment projects out from the surface of the elastic portion when said headband is not sufficiently tight, thus creating a loop which provides a visual indication that the headband needs re-tightening.

18. The headband of claim 17 wherein said non-elastic segment is sized to not project out from the surface of the elastic portion when said headband is sufficiently tight thus indicating an adequate level of tension corresponding with delivering a pressure in the range higher than the venous pressure and lower than the capillary pressure to the oximetry sensor applied to the forehead of the patient.

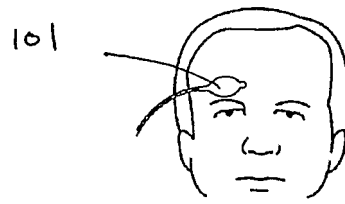

Fig. 1

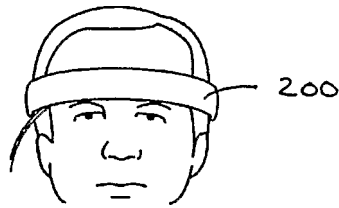

Fig. 2

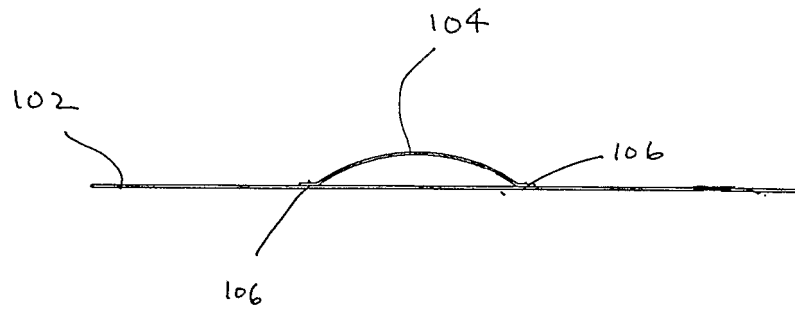

Fig. 3

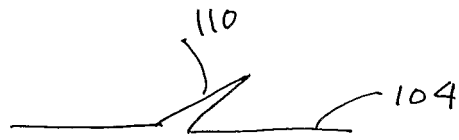

Fig. 4A

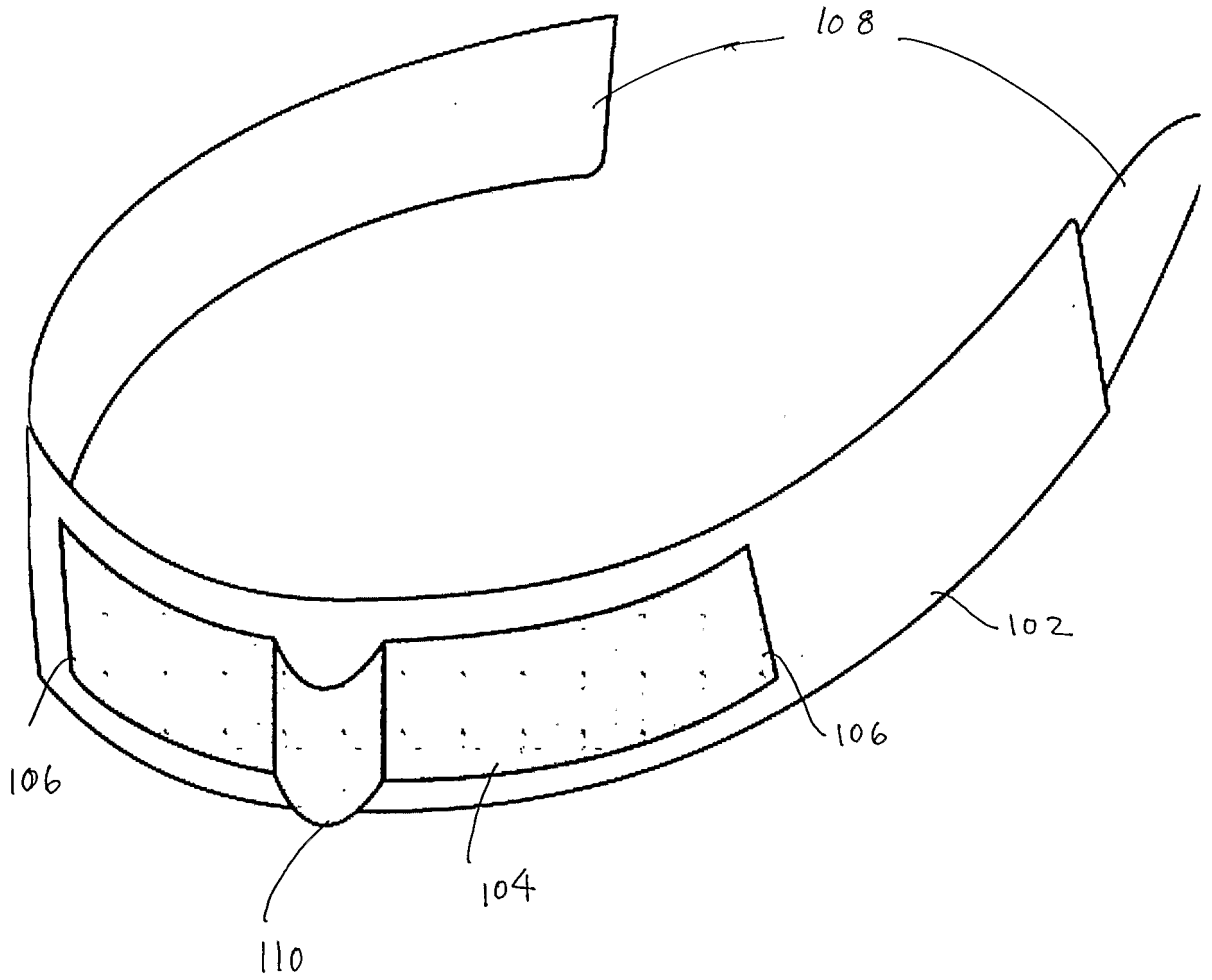

Fig. 4

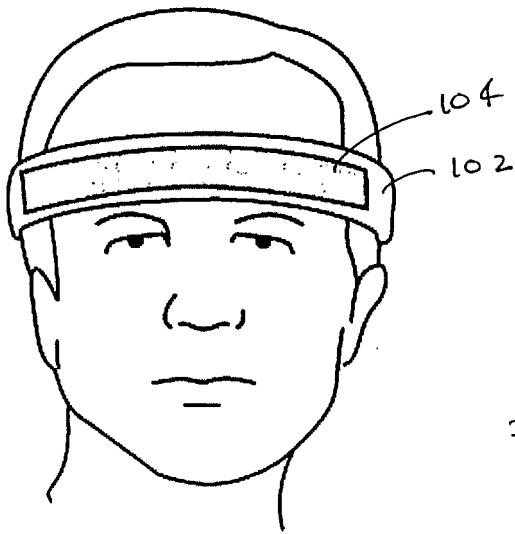

Fig. 5

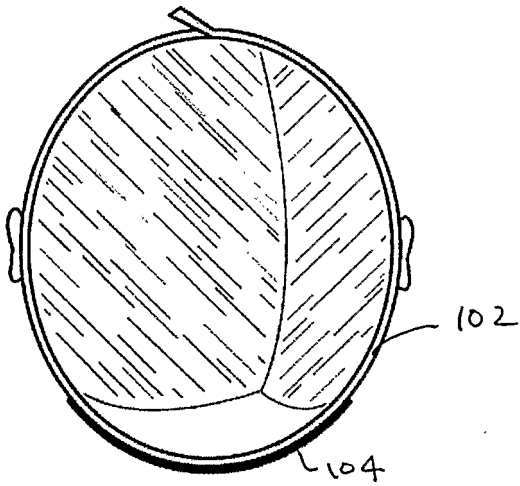

Fig. 6

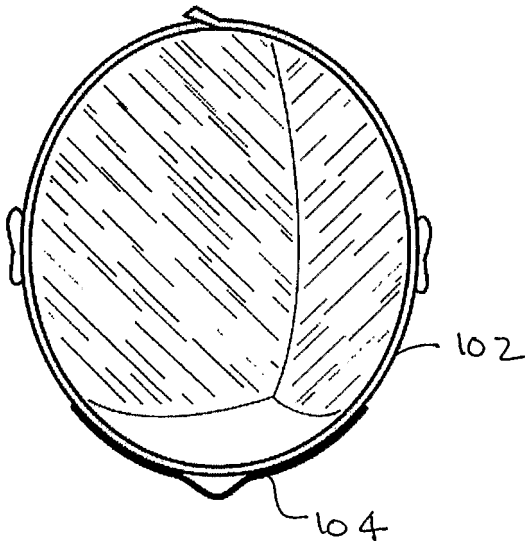

Fig. 7

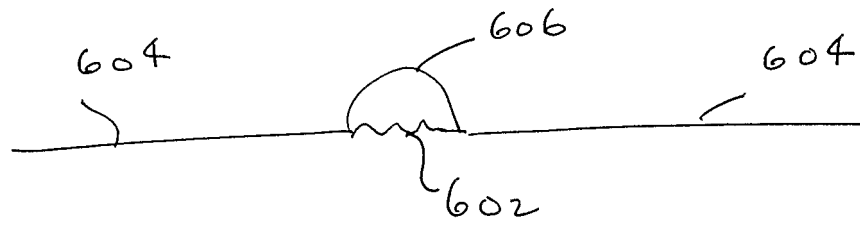

Fig. 8

**INTERNATIONAL SEARCH REPORT**

Internation Application No  
PCT/US 03/31208

**A. CLASSIFICATION OF SUBJECT MATTER**  
IPC 7 A41D20/00 //A61B5/00

According to International Patent Classification (IPC) or to both national classification and IPC

**B. FIELDS SEARCHED**

Minimum documentation searched (classification system followed by classification symbols)  
IPC 7 A41D A61B

Documentation searched other than minimum documentation to the extent that such documents are included in the fields searched

Electronic data base consulted during the international search (name of data base and, where practical, search terms used)

EPO-Internal

**C. DOCUMENTS CONSIDERED TO BE RELEVANT**

Category °	Citation of document, with indication, where appropriate, of the relevant passages	Relevant to claim No.
X	US 5 826 277 A (MCCONVILLE CHRISTINA H) 27 October 1998 (1998-10-27)	1,4,5,7
Y	the whole document	2,3
A	US 4 462 116 A (SANZONE SALVATORE J ET AL) 31 July 1984 (1984-07-31) column 3, line 9 - line 14	1-18
X	US 4 977 011 A (SMITH CAROL L) 11 December 1990 (1990-12-11) column 3, line 31 - line 33; claims 1,11; figures	8,9,11,12
Y	column 6, line 6; figure 10	10
Y	DE 295 15 877 U (VOGEL MEINOLPH) 30 November 1995 (1995-11-30) page 1, paragraph 1	2,3,10
	-/--	

Further documents are listed in the continuation of box C.

Patent family members are listed in annex.

° Special categories of cited documents :

- \*A\* document defining the general state of the art which is not considered to be of particular relevance
- \*E\* earlier document but published on or after the international filing date
- \*L\* document which may throw doubts on priority claim(s) or which is cited to establish the publication date of another citation or other special reason (as specified)
- \*O\* document referring to an oral disclosure, use, exhibition or other means
- \*P\* document published prior to the international filing date but later than the priority date claimed

- \*T\* later document published after the international filing date or priority date and not in conflict with the application but cited to understand the principle or theory underlying the invention
- \*X\* document of particular relevance; the claimed invention cannot be considered novel or cannot be considered to involve an inventive step when the document is taken alone
- \*Y\* document of particular relevance; the claimed invention cannot be considered to involve an inventive step when the document is combined with one or more other such documents, such combination being obvious to a person skilled in the art.
- \*Z\* document member of the same patent family

Date of the actual completion of the international search

5 February 2004

Date of mailing of the international search report

20/02/2004

Name and mailing address of the ISA

European Patent Office, P.B. 5818 Patentlaan 2  
NL - 2280 HV Rijswijk  
Tel. (+31-70) 340-2040, Tx. 31 651 epo nl,  
Fax: (+31-70) 340-3016

Authorized officer

Uhlig, R

INTERNATIONAL SEARCH REPORT

International Application No  
PCT/US 03/31208

C.(Continuation) DOCUMENTS CONSIDERED TO BE RELEVANT

Category °	Citation of document, with indication, where appropriate, of the relevant passages	Relevant to claim No.
X	US 4 856 116 A (SULLIVAN LLOYD S) 15 August 1989 (1989-08-15) column 5, line 46 - line 61; figures 1,2 ---	14,17
A	EP 0 631 756 A (HAMAMATSU PHOTONICS KK) 4 January 1995 (1995-01-04) page 2, line 3; figure 2 ---	14-18
A	US 4 991 234 A (GREENBERG BERT) 12 February 1991 (1991-02-12) figures 6-9 -----	1-7

# INTERNATIONAL SEARCH REPORT

information on patent family members

International	Location No
PCT/US 03/31208	

Patent document cited in search report	A	Publication date	Patent family member(s)	Publication date
US 5826277	A	27-10-1998	NONE	
US 4462116	A	31-07-1984	NONE	
US 4977011	A	11-12-1990	WO 9204183 A1 US 5209801 A	19-03-1992 11-05-1993
DE 29515877	U	30-11-1995	DE 29515877 U1	30-11-1995
US 4856116	A	15-08-1989	NONE	
EP 0631756	A	04-01-1995	EP 0631756 A1 DE 69309261 D1 DE 69309261 T2 JP 7008473 A	04-01-1995 30-04-1997 03-07-1997 13-01-1995
US 4991234	A	12-02-1991	NONE	

专利名称(译)	带张力指示器的头带		
公开(公告)号	<a href="#">EP1549165A1</a>	公开(公告)日	2005-07-06
申请号	EP2003773086	申请日	2003-10-01
[标]申请(专利权)人(译)	内尔科尔普里坦贝内特公司		
申请(专利权)人(译)	NELLCOR PURITAN BENNETT INCORPORATED		
当前申请(专利权)人(译)	NELLCOR PURITAN BENNETT LLC		
[标]发明人	HANNULA DON COAKLEY JOSEPH		
发明人	HANNULA, DON COAKLEY, JOSEPH		
IPC分类号	A41D20/00 A61B5/00		
CPC分类号	A61B5/6814 A41D20/00 A61B5/01 A61B5/14552		
优先权	60/415468 2002-10-01 US		
其他公开文献	EP1549165B8 EP1549165B1		
外部链接	<a href="#">Espacenet</a>		

#### 摘要(译)

一种头带 ( 102 ) , 其具有张力指示器 ( 110 ) , 该张力指示器 ( 110 ) 具有弹性部分 ( 102 ) , 该弹性部分 ( 102 ) 的尺寸适于围绕佩戴者的头部;非弹性段 ( 104 ) 小于弹性段 ( 102 ) 并与弹性段 ( 102 ) 连接。当弹性段被拉伸时, 非弹性段 ( 104 ) 的尺寸设计成跨越弹性段 ( 102 ) 的一部分, 并且非弹性段 ( 104 ) 大于弹性段 ( 102 ) 的部分。当弹性段 ( 102 ) 未被拉伸时跨越。非弹性段 ( 104 ) 与弹性段连接, 使得当头带不够紧时非弹性段 ( 104 ) 从弹性部分的表面突出, 从而形成环 ( 110 ) 提供头带需要重新收紧的视觉指示。