

(19)



(11)

EP 3 123 937 B1

(12)

EUROPEAN PATENT SPECIFICATION

(45) Date of publication and mention of the grant of the patent:
28.08.2019 Bulletin 2019/35

(51) Int Cl.:
A61B 5/024 ^(2006.01) **A61B 5/1455** ^(2006.01)
A61B 10/00 ^(2006.01) **A61B 5/00** ^(2006.01)
H05B 33/08 ^(2006.01)

(21) Application number: **15178625.8**

(22) Date of filing: **28.07.2015**

(54) BIOMETRIC SENSOR ARRANGEMENT AND METHOD FOR GENERATING A BIOMETRIC SIGNAL

BIOMETRISCHE SENSORANORDNUNG UND VERFAHREN ZUR ERZEUGUNG EINES BIOMETRISCHEN SIGNALS

AGENCEMENT DE CAPTEUR BIOMÉTRIQUE ET PROCÉDÉ DE GÉNÉRATION D'UN SIGNAL BIOMÉTRIQUE

(84) Designated Contracting States:
AL AT BE BG CH CY CZ DE DK EE ES FI FR GB GR HR HU IE IS IT LI LT LU LV MC MK MT NL NO PL PT RO RS SE SI SK SM TR

(74) Representative: **Epping - Hermann - Fischer**
Patentanwalts-gesellschaft mbH
Schloßschmidstraße 5
80639 München (DE)

(43) Date of publication of application:
01.02.2017 Bulletin 2017/05

(56) References cited:
US-A1- 2005 075 553 US-A1- 2013 272 688
US-A1- 2015 133 756 US-A1- 2015 190 094
US-A1- 2015 196 239

(73) Proprietor: **ams AG**
8141 Premstätten (AT)

(72) Inventor: **ENENKEL, Jan**
8101 Gratkorn (AT)

EP 3 123 937 B1

Note: Within nine months of the publication of the mention of the grant of the European patent in the European Patent Bulletin, any person may give notice to the European Patent Office of opposition to that patent, in accordance with the Implementing Regulations. Notice of opposition shall not be deemed to have been filed until the opposition fee has been paid. (Art. 99(1) European Patent Convention).

Description

[0001] The present application is related to a biometric sensor arrangement and a method for generating a biometric signal.

[0002] A biometric sensor arrangement can be configured to determine the heart rate of a user. Such a biometric sensor arrangement comprises one light source and one light sensor to measure pressure changes in the capillaries of the human skin of a user. The light source emits radiation which is spread through the tissue to the capillaries. The light sensor then measures the optical response through the skin. The heart rate can be determined as a function of the optical response. There is an increased demand to realize small and cost-effective biometric sensor arrangements.

[0003] Document US 2005/0075553 A1 describes a portable biological information monitor apparatus. An information detection unit comprises a green light-emitting diode (abbreviated LED), an infrared LED, a driver and a photo detector connected to an analog-to-digital converter. The driver is started in accordance with a command from a processor and drives the LEDs alternately at different timings.

[0004] Document US 2015/0133756 A1 explains a system for determining physiological characteristics of a patient using pulse oximetry. An oximetry sensor comprises two radiation emitters emitting in the red and the infrared regime, a signal conditioning and filtering element connected to the emitters, a detector and a further signal conditioning and filtering element connected to the detector. The two emitters are connected in parallel with opposing polarities such that in operation one emitter will be activated by positive driving signals, while the other emitter will be activated by negative driving signals.

[0005] Document US 2015/0190094 A1 is related to a sensor device and an electronic device having a sensor device. The electronic device includes a substrate, a heart rate sensor (HR sensor) mounted on the substrate, a flash light emitting diode (LED) placed adjacent to the HR sensor, an integral window placed in a housing to cover the HR sensor and the flash LED all together, and a shielding unit configured to provide shielding between an area of the HR sensor and an area of the flash LED. The HR sensor device may detect the user's pulse or oxygen saturation by allowing light to pass through or be reflected by a human blood vessel by using an LED or an infrared LED and detecting returning light by using a photo detector or a photo diode.

[0006] It is an object of the present patent application to provide a biometric sensor arrangement and a method for generating a biometric signal which can be combined with other devices.

[0007] This object is achieved by the subject-matter of the independent claims. Further embodiments are subject of dependent claims.

[0008] In an embodiment, a biometric sensor arrangement comprises a first and a second radiation source, a

driver, a photosensor and a signal conditioning unit. The driver is coupled to the first and the second radiation source and is configured to selectively operate the first and the second radiation source. The signal conditioning unit is coupled to the photosensor and designed to provide a biometric signal. Advantageously, the first radiation source is combined with the second radiation source and the driver that supplies both the first and the second radiation source. Thus, the driver controls the operating of the first and the second radiation source avoiding an interference between the two radiation sources. At least the first radiation source is used for biometric sensing.

[0009] In an embodiment, the second radiation source is implemented as a flash radiation source. The second radiation source may be used for another purpose than biometric sensing. A mobile device typically comprises a radiation source. Thus, the second radiation source may be used for a function of the mobile device. Advantageously, the functions of the biometric sensor arrangement and of the mobile device could be combined.

[0010] In an embodiment, the first radiation source is implemented as a black-body radiator, a laser, a lamp such as incandescent lamp or a Nernst lamp, a heater or a light-emitting diode, abbreviated LED.

[0011] A radiation emitted by the first radiation source may be a visible light, an ultraviolet light or an infrared light.

[0012] The second radiation source is realized as flash LED. The flash LED is designed to be able to emit a flash. The flash LED is fabricated for conducting a high current. The current flowing through the flash LED may be higher than 200 mA. Alternatively, the current may be higher than 500 mA or 1000 mA.

[0013] In an embodiment, the photosensor is configured to provide a photon signal. The photon signal may be a function of radiation emitted by the first radiation source.

[0014] In an embodiment, the photosensor is implemented as a photodiode or a phototransistor.

[0015] In an embodiment, the signal conditioning unit is configured such that the biometric signal is a function of the photon signal.

[0016] In an embodiment, the driver is configured to operate the first radiation source in a first operating phase and to operate the second radiation source in a second operating phase. The first and the second operating phases are free of an overlap. The signal conditioning unit may be configured to provide the biometric signal depending on the photon signal during the first operating phase.

[0017] In an embodiment, the signal conditioning unit is configured to provide the biometric signal independent from the photon signal in the second operating phase.

[0018] In an embodiment, the second radiation source emits a flash during the second operating phase. The driver is realized to provide a sufficient electric power supply to the second radiation source in the second operating phase.

[0019] In an embodiment, the first radiation source is configured to protect the second radiation source, for example in case of an electrostatic discharge event, abbreviated ESD event.

[0020] In an embodiment, the first and the second radiation source are both implemented as LED. The first and the second radiation source form an anti-parallel circuit of diodes. Thus, an anode of the first radiation source is connected to a cathode of the second radiation source and a cathode of the first radiation source is connected to an anode of the second radiation source. Since the anti-parallel circuit of the first and the second radiation source only has two terminals, the driver also requires only exactly two driver terminals to supply electric power to the first radiation source as well as to the second radiation source.

[0021] In an embodiment, the first radiation source is configured to emit radiation at a first wavelength and the second radiation source is configured to emit radiation at a second wavelength. The first wavelength is different from the second wavelength.

[0022] In an embodiment not covered by the invention, the signal conditioning unit is configured to provide the biometric signal depending from the photon signal in the first and the second operating phase. The photon signal in the second operating phase may be used for on-line calibration or reducing the influence of disturbing parameters, a baseline or a drift.

[0023] In an embodiment, the driver is realized as an H-bridge. The H-bridge is configured to selectively supply the first and the second radiation source.

[0024] In an embodiment, the H-bridge comprises a converter, a switch, a current source and a further current source. The H-bridge is configured such that the converter and the current source supply the second radiation source and that the further current source and the switch supply the first radiation source. The current source is arranged between a first driver terminal and a reference potential terminal. The further current source is located between the first driver terminal and a supply terminal. The converter is arranged between the supply terminal and a second driver terminal. The switch is located between the second driver terminal and the reference potential terminal. The first and the second radiation source are coupled between the first and the first driver terminal.

[0025] In an alternative embodiment, the driver comprises the current source, the further current source and the converter. The further current source couples the supply terminal to the first driver terminal. The current source couples an output of the converter to the first driver terminal. The first driver terminal is connected to a terminal of the first radiation source and to a terminal of the second radiation source. A further terminal of the first radiation source and a further terminal of the second radiation source may be coupled to the reference potential terminal, for example directly or via the switch. The converter generates a converter voltage. The converter voltage may have an opposite polarity in comparison to a

supply voltage tapped at the supply terminal. The converter voltage may be negative with respect to the reference potential terminal. Thus, in the first operating phase, a positive voltage may be applied to the first driver terminal and, in the second operating phase, a negative voltage may be applied to the first driver terminal. Advantageously, the converter is realized as a negative voltage circuit for a p-channel metal-oxide-semiconductor flash current source, abbreviated PMOS Flash current source.

[0026] In an embodiment, the driver comprises a signal terminal coupled to a signal terminal of the signal conditioning unit for synchronizing the operation of the first radiation source with the operation of the signal conditioning unit. The signal terminal of the driver may be a signal output terminal and the signal terminal of the signal conditioning unit may be a signal input terminal that is connected to the signal output terminal of the driver.

[0027] In an embodiment, the signal conditioning unit comprises a transimpedance amplifier for amplifying the photon signal.

[0028] In an embodiment, the first and the second radiation source are located in vicinity of each other. The first and the second radiation source may emit radiation through the same opening or the same transparent window of a housing enclosing the biometric sensor arrangement. Only one opening or transparent window is necessary for the first and the second radiation source. The first and the second radiation source may both be arranged on a common carrier or common substrate.

[0029] In a further development, the photosensor receives radiation through the same opening or the same transparent window that is designed for emitting radiation by the first and the second radiation source. Thus, the photosensor may be arranged on the common carrier or the common substrate in vicinity to the first and the second radiation source.

[0030] In an embodiment, the biometric sensor arrangement is configured to determine the heart rate of a user, also called pulse of the user. The biometric sensor arrangement is implemented as heart rate sensor, heart rate monitor or photoplethysmograph. The biometric sensor arrangement is designed to measure the normal resting adult human heart rate ranging from 60 to 100 beats per minute, abbreviated bpm, and the heart rate during a tachycardia, also called tachyarrhythmia that is a heart rate exceeding the normal resting rate caused by exercise of a person or by a problem within the heart. The biometric sensor arrangement may be designed to measure heart rates in an interval of 30 bpm to 250 bpm.

[0031] Alternatively or additionally, the biometric sensor arrangement is configured to determine at least one parameter in the skin of a user of a group consisting of a melanin concentration, a water concentration, a fat concentration, an alcohol concentration and an oxygen concentration. The oxygen concentration may be a blood oxygen concentration or the oxygen saturation level of arterial blood.

[0032] In an embodiment, the biometric sensor arrangement is configured as pulse oximeter that measures the oxygen saturation level as well as the pulse. Thus, the heart rate measurement may be combined with the oxygen measurement.

[0033] In an embodiment, a mobile device comprises the biometric sensor arrangement. The mobile device may be realized as a watch or a mobile telecommunication device, such as mobile phone or mobile smartphone. The mobile device may comprise a camera. The camera may be coupled to the second radiation source. Thus, the second radiation source realized as a flash radiation source may be used for the implementation of the camera. The second radiation source may generate a flash for the operation of the camera.

[0034] In an embodiment, a method for generating a biometric signal comprises selectively operating a first and a second radiation source by a driver. The second radiation source may be implemented as a flash radiation source. A photon signal is provided by a photosensor as a function of radiation emitted by the first radiation source. The biometric signal is provided by a signal conditioning unit as a function of the photon signal.

[0035] Advantageously, the driver can select the operating of the first and the second radiation source for avoiding an interference of the function which is performed by the first radiation source and the function which is performed by the second radiation source. Light may be a form of radiation.

[0036] In an embodiment, the biometric sensor arrangement uses a driver of a flash LED. A signal processing unit of the heart rate sensor is connected either to an integrated sensing photodiode or an external sensing photodiode.

[0037] In an embodiment, the driver of a flash LED is implemented as an emission source for biometric sensing.

[0038] In an embodiment, the first radiation source is implemented as an ESD Diode of the flash LED in reversed polarity to emit a light of a particular wavelength - such as red, green, IR - and shining it into a living organism to measure biometric signals, for example heart rate.

[0039] In an embodiment, the driver is designed either as an H-Bridge circuit with current sink/source. Alternatively, the driver comprises a negative voltage circuit for a p-channel metal-oxide-semiconductor flash current source, abbreviated PMOS Flash current source.

[0040] In an embodiment, the driver synchronizes the emission of a biometric sensing process with an external photo measurement device, such as a photodiode.

[0041] In an embodiment, the first radiation source is implemented as a reversed ESD diode which does emit an optical signal for measuring biometric information of a living object.

[0042] In an embodiment, the second radiation source indicates to a user where to put his finger when he wants to measure his heart rate. A switching occurs between a

flash indication pulse provided by the second radiation source and a pulse provided by the first radiation source for measurement of heart rate.

[0043] In an embodiment, the biometric sensor arrangement is configured for the measurement of a biometric signal such as for example melanin, water, fat, alcohol, heartrate and blood oxygen.

[0044] The first radiation source may emit light with a wavelength between 300 nm to 700 nm for the detection of melanin. A group of natural pigments found in most organism is called melanin.

[0045] The first radiation source may emit light with a wavelength between 1150 nm to 2000 nm - such as 1600 nm - for the measurement of water. A small water concentration may be a hint of a dehydration of a user.

[0046] The first radiation source may emit light with a wavelength between 1000 nm to 2000 nm for the detection of fat.

[0047] In an embodiment, the biometric sensor arrangement is realized as pulse oximeter. The first radiation source may emit light with a wavelength between 500 nm to 1000 nm for the detection of blood oxygen. The first radiation source may emit infrared light, for example with a wavelength of 890 nm or 950 nm. The second radiation source or a third radiation source comprised by the biometric sensor arrangement may emit red light, for example at 650 nm or 663 nm. The oxygen saturation level of blood may be calculated as a function of the photon signal received in response to the infrared light and of the photon signal received in response to the red light.

[0048] In an embodiment, a synchronization signal is generated for the synchronization of the driver and the photodiode that senses the biometric signal and is integrated with a signal conditioning unit.

[0049] The following description of figures may further illustrate and explain exemplary embodiments. Insofar as components, circuits and method steps correspond to one another in terms of their function in different figures, the description thereof is not repeated for each of the following figures.

Figures 1A to 1G show an exemplary embodiment of a biometric sensor arrangement;

Figures 2A to 2D show alternative exemplary embodiments of a biometric sensor arrangement; and

Figures 3A to 3E show an exemplary embodiment of an interaction of a biometric sensor arrangement with a user and of mobile devices comprising a biometric sensor arrangement.

[0050] Figure 1A shows an exemplary embodiment of a biometric sensor arrangement 10 which comprises a first radiation source 11 and a second radiation source

12. Moreover, the biometric sensor arrangement 10 comprises a driver 13 that is connected to the first and the second radiation source 11, 12. A first driver terminal 14 of the driver 13 is connected to first terminals of the first and the second radiation source 11, 12. A second driver terminal 15 of the driver 13 is connected to second terminals of the first and the second radiation source 11, 12. The first and the second radiation source 11, 12 emit radiation, the radiation may be light.

[0051] The second radiation source 12 may be fabricated as a flash radiation source. Thus, the second radiation source 12 may be configured to emit a flash of visible light, for example white light. The second radiation source 12 may be designed to conduct a pulse current higher than 200 mA, alternatively higher than 500 mA or 1 A.

[0052] The first and the second radiation source 11, 12 are realized as light-emitting diodes, abbreviated LEDs. The first radiation source 11, for example, is realized as infrared LED. The first radiation source 11 is designed as an electrostatic discharge protection diode, abbreviated ESD diode. The second radiation source 12 may be implemented as white LED.

[0053] The first and the second radiation source 11, 12 are configured as an anti-parallel circuit of diodes. An anode of the first radiation source 11 is directly connected to a cathode of the second radiation source 12. An anode of the second radiation source 12 is directly connected to a cathode of the first radiation source 11. Thus, the anode of the first radiation source 11 and the cathode of the second radiation source 12 are connected to the first driver terminal 14. The anode of the second radiation source 12 and the cathode of the first radiation source 11 are connected to the second driver terminal 15.

[0054] Additionally, the biometric sensor arrangement 10 comprises a photosensor 16. The photosensor 16 comprises a photodiode 17. The biometric sensor arrangement 10 comprises a signal conditioning unit 18 that is coupled to the photosensor 16 and, thus, to the photodiode 17. The signal conditioning unit 18 is connected to two terminals of the photodiode 17. The photodiode 17 may be implemented as BPW34 diode fabricated by Vishay Intertechnology, Inc. or OSRAM Opto Semiconductors GmbH, Regensburg, Germany.

[0055] Furthermore, the biometric sensor arrangement 10 comprises a logic circuit 19. The logic circuit 19 is connected to the signal conditioning unit 18. The logic circuit 19 may be realized as an inter-integrated circuit, abbreviated I²C circuit. The logic circuit 19 may comprise registers. The biometric sensor arrangement 10 comprises an inter-integrated circuit interface 20, abbreviated I²C interface, connected to the logic circuit 19, as well as further signal terminals 21, connected to the logic circuit 19. The biometric sensor arrangement 10 is connected to a supply terminal 22 and to a reference potential terminal 23.

[0056] The driver 13 is realized as an H-bridge. The driver 13 comprises a converter 24. The converter 24 is

realized as a DC-to-DC converter. The converter 24 is coupled between the supply terminal 22 and the second driver terminal 15. Moreover, the driver 13 comprises a switch 25. The switch 25 couples the second driver terminal 15 to the reference potential terminal 23. The switch 25 may be realized as a field-effect transistor. The switch 25 may be implemented as an n-channel metal-oxide-semiconductor field-effect transistor.

[0057] Furthermore, the driver 13 comprises a current source 26 that couples the first driver terminal 14 to the reference potential terminal 23. Additionally, the driver 13 comprises a further current source 27 that is arranged between the supply terminal 22 and the first driver terminal 14. The driver 13 comprises a control unit 28. The control unit 28 may be designed as a state machine. Alternatively, the control unit 28 may be implemented by a microprocessor or a microcontroller. The control unit 28 can be realized as heart rate control unit. The control unit 28 is connected to a control terminal of the switch 25 and a control terminal of the further current source 27. Additionally, the control unit 28 may also be connected to a control terminal of the current source 26. Furthermore, the control unit 28 can also be connected to a control terminal of a converter controller 29 of the converter 24, the signal conditioning unit 18 and the logic circuit 19. A driver capability of the current source 26 may be larger than a driver capability of the further current source 27.

[0058] The converter 24 is implemented as an inductive DC-to-DC converter. The converter 24 is realized as a step-up or Boost converter. The converter 24 comprises an inductor 30 having a first terminal connected to the supply terminal 22. A second terminal of the inductor 30 is coupled via a first converter switch 31 of the converter 24 to the second driver terminal 15. The second terminal of the inductor 30 is coupled via a second converter switch 32 of the driver 24 to the reference potential terminal 23. An output capacitor 33 couples the first terminal 15 to the reference potential terminal 23. An input capacitor 34 is arranged between the supply terminal 22 and the reference potential terminal 23. The converter controller 29 is connected to the control terminal of the first and the second converter switch 31, 32 and to the supply terminal 22. The first and the second converter switch 31, 32 are realized as field-effect transistors.

[0059] The signal conditioning unit 18, the control unit 28, the logic circuit 19, the current source 26, the further current source 27, the switch 25 and parts of the converter 24 are integrated on a semiconductor substrate 35. The first and the second converter switch 31, 32 and the converter controller 29 are integrated on the semiconductor substrate 35. The photosensor 16 is not implemented on the semiconductor substrate 35. The semiconductor substrate 35 is free of any photosensor. Also the first and the second radiation source 11, 12, the supply capacitor 34 and the output capacitor 33 are not integrated on the semiconductor substrate 35. Furthermore, the inductor 30 of the converter 24 is not realized on the semiconductor substrate 35.

[0060] The biometric sensor arrangement 10 comprises a further semiconductor substrate 36. The photosensor 16 is integrated on the further semiconductor substrate 36.

[0061] As the further semiconductor substrate 36 with the receiving photodiode 17 is not having any analog amplification circuitry, a cost improvement due to regular diode process is achieved. Realizing the photodiode 17 without integration with another circuit, the size of the photodiode 17 can be bigger as there is no cost pressure which does improve an optical integration of movement fractures. This results in a better signal quality.

[0062] The signals and the operation of the biometric sensor arrangement 10 is explained using Figures 1B and 1C. The biometric sensor arrangement 10 is operated in a first operating phase A and in a second operating phase B. The first operating phase A is shown in Figure 1B, whereas the second operating phase B is shown in Figure 1C.

[0063] In an alternative, not shown embodiment, the converter 24 may be realized as a capacitive DC-to-DC converter.

[0064] In an alternative, not shown embodiment, the converter 24 may be realized as step-down or step-up/step-down converter, also named Buck or Buck-Boost converter.

[0065] Alternatively, the second radiation source 12 does not operate as a flash radiation source. For example, the second radiation source 12 may contribute to the detection of a parameter of a user by the first radiation source 11 and the photosensor 16 or may operate as backlight of a display or as an indicator light.

[0066] Figure 1B shows the first operating phase A of the biometric sensor arrangement 10 illustrated in Figure 1A. A battery voltage VBAT is provided to the supply terminal 22. A reference potential GND is tapped at the reference potential terminal 23. A first and a second I2C signal SDA, SCL are applied at the two terminals of the I2C interface 20. The further signals STR, TXM, INT are applied at the further signal terminals 21 and, thus, at the logic unit 19. The control unit 28 controls the first and the second operating phase A, B. In the first operating phase A, the converter 24 and the current source 26 are deactivated by the control unit 28. In the first operating phase A, no current flows through the converter 24 and the current source 26.

[0067] In the first operating phase A, the further current source 27 is activated and the switch 25 is set in a conducting state by the control unit 28. The polarity of the first radiation source 11 is designed such that a first current I1 can flow through the first radiation source 11. Thus, the first current I1 is controlled by the further current source 27 and flows through the first radiation source 11 and the switch 25. Therefore, the first current I1 flows from the supply terminal 22 via the further current source 27, the first driver terminal 14, the first radiation source 11, the second driver terminal 15 and the switch 25 to the reference potential terminal 23.

[0068] In the first operating phase A, no current flows through the second radiation source 12. The polarity of the second radiation source 12 is designed such that the first current I1 cannot flow through the second radiation source 12 in the first operating phase A.

[0069] During the first operating phase A, the photodiode 17 of the photosensor 16 generates a photon signal SP that is provided to the signal conditioning unit 18. The signal conditioning unit 18 generates a biometric signal SB that is provided to the logic circuit 19. The logic circuit 19 delivers the information comprised by the biometric signal SB via the I2C terminals 20 or the further signal terminals 21 to a not shown microprocessor, microcontroller or computer.

[0070] Alternatively, the signal conditioning unit 18 performs an analog signal conversion or analog and digital signal conversion of the photon signal SP. The signal conditioning unit 18 provides a modified photon signal SP' to the logic circuit 19. The logic circuit 19 generates the biometric signal SB. The logic circuit 19 delivers the biometric signal SB via the I2C terminals 20 or the further signal terminals 21 to a not shown microprocessor, microcontroller or computer.

[0071] Figure 1C shows the second operating phase B of the biometric sensor arrangement 10 illustrated in Figures 1A and 1B. In the second operating phase B, the switch 25 is set in a non-conducting state by the control unit 28. Additionally, the further current source 27 is deactivated by the control unit 28. The control unit 28 activates the converter 24. For this purpose, the control unit 28 provides a signal to the converter controller 29. In the second operating phase B, the converter 24 performs a DC/DC conversion of the battery voltage VBAT into an output voltage VOUT. The output VOUT can be tapped between the second driver terminal 15 and the reference potential terminal 23. The output voltage VOUT is applied across the output capacitor 33.

[0072] The second converter switch 32 is set in a conducting state and the first converter switch 31 is set in a non-conducting state in a first converter phase B1 of the converter 24. The battery voltage VBAT mainly drops across the inductor 30. Thus, an inductor current IL that flows through the inductor 30 rises in the first converter phase B1. The inductor current IL flows from the supply terminal 22 via the inductor 30 and the second converter switch 32 to the reference potential terminal 23 in the first converter phase B1.

[0073] In a second converter phase B2, the first converter switch 31 is set in a conducting state and the second converter switch 32 is set in a non-conducting state. The second converter phase B2 follows the first converter phase B1. In the second converter phase B2, the inductor current IL flows from the supply terminal 22 through the inductor 30 and the first converter switch 31 to the output of the converter 22 and charges the output capacitor 33. Thus, the output voltage VOUT is increased during the second converter phase B2.

[0074] The converter controller 29 controls the first and

the second converter switch 31, 32. The first and the second converter phases B1, B2 are periodically repeated, for example with a frequency of 4 MHz. The output voltage VOUT will be increased until the output voltage VOUT obtains a value sufficient for a flash provided by the second radiation source 12.

[0075] In the second operating phase B, the second radiation source 12 provides a flash, when the current source 26 is triggered by the control unit 28. Thus, the flash occurs in a flash operating period B3 after repeating the first and the second converter phase B1, B2 several times. During the flash operating period B3, a second current I2 flows through the second radiation source 12 generating the flash of light. The second current I2 is controlled by the current source 26. During the flash operating period B3, the second current I2 flows from the output capacitor 33 via the second radiation source 12, the first driver terminal 14 and the current source 26 to the reference potential terminal 23.

[0076] By the flash of the second radiation source 12, the output voltage VOUT is decreased. However, the value of the output voltage VOUT may still be higher than 0 V. At the start of the next first operating phase A, the output voltage VOUT is set to zero by the switch 25.

[0077] Figure 1D shows an exemplary embodiment of the signal conditioning unit 18 of the biometric sensor arrangement 10 shown in Figure 1A to 1C. The signal conditioning unit 18 comprises a transimpedance amplifier 37 that is connected on its input side to the photodiode 17. The photodiode 17 is connected to the input of the transimpedance amplifier 37.

[0078] The transimpedance amplifier 37 comprises an operational amplifier 38. A feedback resistor 39 couples a first input of the operational amplifier 38 to an output of the operational amplifier 38. Moreover, a feedback capacitor 40 is arranged between the first input of the operational amplifier 38 and the output of the operational amplifier 38. A terminal of the photodiode 17 is connected to the first input of the operational amplifier 38. A further terminal of the photodiode 17 and a second input of the operational amplifier 38 are connected to the reference potential terminal 23. The output of the operational amplifier 38 is connected to an output of the transimpedance amplifier 37. The first input of the operational amplifier 38 is realized as an inverting input and the second input of the operational amplifier 38 is implemented as a non-inverting input.

[0079] Furthermore, the signal conditioning unit 18 comprises an analog-to-digital converter 42 coupled to the output of the transimpedance amplifier 37. The signal conditioning unit 18 comprises a filter 41 coupling the output of the transimpedance amplifier 37 to the analog-to-digital converter 42. The filter 41 may be realized as a low-pass filter. Moreover, the signal conditioning unit 18 may comprise a calculation unit 43. The calculation unit 43 is connected on its input side to the analog-to-digital converter 42. The calculation unit 43 is coupled on its output side to the logic circuit 19.

[0080] The photon signal SP is provided to the transimpedance amplifier 37. The analog-to-digital converter 42 generates a modified photon signal SP'. The calculation unit 43 generates the biometric signal SB as a function of the photon signal SP. The calculation unit 43 may comprise a state machine, a microcontroller or a microprocessor.

[0081] As the transimpedance amplifier 37 can be driven by a bigger photodiode 17, a lower gain of the transimpedance amplifier 37 can be set. This results in a better signal-to-noise ratio inside the signal conditioning circuit 18.

[0082] In an alternative, not shown embodiment, the signal conditioning unit 18 does not comprise a calculation unit 43. The analog-to-digital converter 42 is connected to the logic circuit 19. The logic circuit 19 calculates the biometric signal SB.

[0083] Figure 1E shows an exemplary embodiment of the operating phases of the biometric sensor arrangement 10. In an example, the biometric sensor arrangement 10 first operates in the first operating phase A and then in the second operating phase B. When the second operating phase B starts, then the converter 24 generates the output voltage VOUT by a sequence of the first and the second converter phases B1, B2. After this sequence of the first and the second converter phases B1, B2, a flash is emitted by the second radiation source 12 during the flash operating phase B3. The first operating phase A and the second operating phase B do not overlap. There may be an idle phase between the first and the second operating phase A, B.

[0084] Other sequences are possible: The biometric sensor arrangement 10 may operate using more than one first operating phase A until it operates using the second operating phase B. Alternatively, the biometric sensor arrangement 10 may operate using one or more than one second operating phase B until it operates using the first operating phase A. The sequence of the first and the second converter phases B1, B2 may consist of exactly one first converter phase B1 and of exactly one second converter phase B2.

[0085] Figures 1F and 1G show examples of measurements of different embodiments of the biometric sensor arrangement 10. In Figures 1F and 1G, the response of the photodiode 17 in artificial units AI is illustrated as a function of a measurement number NR. The photodiode 17, used to obtain the measurement results shown in Figure 1F, has an area of 7.5 mm², whereas the area of the photodiode 17 used for the measurement shown in Figure 1G has a value of 1 mm². A photodiode 17 with a 7.5 mm² area improves the optical performance compared to a photodiode 17 with 1 mm² area, because more light is received shining through capillaries; therefore, the signal to noise ratio is improved. The ratio can also be named signal to baseline ratio, since the signal generated by a pulse of a user has to be detected in the presence of a signal generated for example by optical refraction from the surface of the skin forming the baseline. A bigger

diode area helps to receive a cleaner photon signal SP in the presence of slight body movements because the refractions are "averaged" more.

[0086] Figure 2A shows an alternative exemplary embodiment of the biometric sensor arrangement 10 which is a further development of the embodiments shown in Figures 1A to 1G. The signal conditioning unit 18 and the photosensor 16 are integrated on the further semiconductor substrate 36. The photosensor 16 is realized as the photodiode 17. The further semiconductor substrate 36 has a further supply terminal 44 that is coupled to the supply terminal 22 and a further reference potential terminal 45 connected to the reference potential terminal 23. The control unit 28 is coupled to the signal conditioning unit 18 via a synchronization connection line 46 and a synchronization pin 47. A data connection line 48 may connect the signal conditioning unit 18 to the logic circuit 19 for providing the biometric signal SB to the logic circuit 19.

[0087] The further semiconductor substrate 36 realizes the photodiode 17 with an integrated signal conditioning unit 18. Advantageously, a disturbance of the photon signal SP is kept low since the connection lines between the signal conditioning unit 18 and the photodiode 17 can be kept very short. The biometric sensor arrangement 10 is realized with the flash LED driver 13 coupled via the synchronization pin 47 to the photodiode 17 with integrated signal conditioning.

[0088] Figure 2B shows a further exemplary embodiment of the biometric sensor arrangement 10 which is a further development of the embodiments shown in Figures 1A to 1G and 2A. The semiconductor substrate 35 also comprises the photosensor 16 having the photodiode 17. Thus, the photosensor 16 is integrated on the semiconductor substrate 35. The semiconductor substrate 35 comprises an integrated photodiode 17. Therefore, the number of pins or pads for the connection of the semiconductor substrate 35 to other components is reduced. Advantageously, the reduced numbers of pins and the reduced length of connection lines result in an increase of the accuracy of the measurements provided by the photodiode 17. The semiconductor substrate 35 comprises the photodiode 17 with the signal conditioning unit 18. The biometric sensor arrangement 10 is implemented as a heart rate sensor with integrated photodiode 17 to use the flash LED as the emitting source 12.

[0089] Figure 2C shows a further exemplary embodiment of the biometric sensor arrangement 10 which is a further development of the embodiments shown in Figures 1A to 1G, 2A and 2B. The converter 28 generates a converter voltage VDC. The converter voltage VDC is negative with respect to the reference potential GND. The converter 24 is connected to the cathode of the second radiation source 12. Thus, for example, the output of the converter 24 is connected via the current source 26 to the second radiation source 12. A converter capacitor 46 is connected between the output of the converter 24 and the reference potential terminal 23.

[0090] In the second operating phase B, the converter 24 generates the converter voltage VDC. The converter capacitor 46 stabilizes the converter voltage VDC. When the value of the converter voltage VDC is sufficient for generating a flash, the control unit 28 sets the switch 25 in a conducting state and activates the current source 26 for triggering the flash. During the flash the second current I2 flows from the converter capacitor 49 through the current source 26, the first driver terminal 14, the second radiation source 12, the second driver terminal 15 and the switch 25 to the reference potential terminal 23. The output capacitor 33 may be omitted. The operation of the biometric sensor arrangement 10 in the first operating phase A is shown in Figure 1B.

[0091] Figure 2D shows a further exemplary embodiment of the biometric sensor arrangement 10 which is a further development of the embodiments shown in Figures 1A to 1G and 2A to 2C. The first and the second radiation source 11, 12 are not arranged as an anti-parallel circuit of diodes. The supply terminal 22 is coupled via the further current source 27, the first driver terminal 14 and the first radiation source 11 to the reference potential terminal 23. The converter 24 is coupled via the current source 26, the second driver terminal 15 and the second radiation source 12 to the reference potential terminal 23. Thus, the anode of the first radiation source 11 is not connected to the anode of the second radiation source 12. The cathode of the first radiation source 11 is connected to the cathode of the second radiation source 12 and to the reference potential terminal 23.

[0092] In the first operating phase A, the further current source 27 is actuated and the current source 26 is deactivated. Thus, the first current I1 flows through the first radiation source 11 and the further current source 27.

[0093] In the second operating phase B, the further current source 27 is deactivated. First the converter 24 charges the converter capacitor 49. When the output voltage VOUT obtains a value sufficient for a flash, the current source 26 is activated. Thus, the second current I2 flows from the converter capacitor 49 via the current source 26 and the second radiation source 12 to the reference potential terminal 23. Since the control unit 28 controls the first and the second operating phase A, B, a simultaneous emitting of light by both radiation sources 11, 12 is avoided.

[0094] Figure 3A shows an exemplary embodiment of an interaction of the biometric sensor arrangement 10 with a user. Thus, the procedure of the heart rate measurement is illustrated. In the upper drawing, the first radiation source 11 emits light to a skin 55 of a user. The skin 55 comprises several layers such as an epidermis layer 56 and a hypodermis layer 57. The light emitted by the first radiation source 11 at least penetrates the epidermis layer 56. Capillaries 58 in the skin 55 will change its volume due to the pressure change caused by a pulse of the user. Thus, the light that is detected by the photosensor 16 depends on the volume of the capillaries 58 and, thus, on the pulse of the user. In the lower drawing,

an examples of the different capillaries 58 are shown.

[0095] The concept is to have one light emitter realized as the first radiation source 11 and one receiver realized as the photosensor 16 having the photodiode 17 to measure the pressure changes in the capillaries 58. The first radiation source 11 emits light such as green, red or IR-light which is spread through the tissue to the capillaries 58. The photosensor 16 - also named photo transducer - measures the optical response through the human skin 55. The photosensor 16 can be implemented for example with analogue photodiodes with external transimpedance converters as shown in Figure 2A or with integrated photodiodes as shown in Figure 2B. The first radiation source 11 may emit radiation with a wavelength between 480 nm to 950 nm.

[0096] Figure 3B shows an exemplary embodiment of a mobile device comprising the biometric sensor arrangement 10 that can be realized as illustrated in one of the Figures 1A to 1G, 2A to 2D and 3A. The mobile device is realized as mobile telecommunication device 59. The mobile telecommunication device 59 comprises the biometric sensor arrangement 10. The mobile telecommunication device 59 comprises a housing 60 or cover. The housing 60 has an opening 61 that is covered by a transparent window. At the inside of the housing 60, the first and the second radiation source 11, 12 and the photosensor 16 are located. The housing 60 comprises a further opening 62 that is also closed by a transparent window. The mobile device may comprises a camera 64 that is located behind the second opening 62. The camera 64 may be realized by a camera semiconductor body.

[0097] Thus, the biometric sensor arrangement 10 may be realized on a backside of the mobile device. The heart rate sensor may be located on the backside of a smartphone. The second radiation source 12 is implemented as flash LED and is connected to a reversed diode realized by the first radiation source 11. The first radiation source 11 can be for example an IR, red or green emitting diode. Advantageously, the second radiation source 12 is located on the backside of the mobile telecommunication device 59 that may be mobile phone or a mobile smartphone.

[0098] Every opening in the backside of the housing 60 of a smartphone represents additional time and effort required for a research&development engineer in terms of designing, qualification testing and production. A reduction of openings 60, 61 and apertures to the inside of the mobile telecommunication device 59 reduces risk of failures, price of production and design efforts. Possible angular issues with the housing backside. Additionally, the smartphone keeps the look of simplicity when the number of openings 60, 61 in the housing 60 is small.

[0099] Also, the biometric sensor arrangement 10 advantageously reduces the cost for healthcare and achieves an improvement in performance.

[0100] The biometric sensor arrangement 10 uses the first radiation source 11 connected to the second radiation source 12 to emit a red, green or IR light for a heart

rate measurement. The first radiation source 11 is a reversed diode and ESD diode to the second radiation source 12 implemented as flash LED. Advantageously, the opening of the flash LED on the backside of the phone can be designed for the emission signal.

[0101] In an alternative, not shown embodiment, the housing 60 comprises an additional opening for the receiving photodiode 17. The reflected radiation is detected through the additional opening. The second radiation source 12 emits through the opening 61. Thus, the photodiode 17 and the second radiation source 12 realizing a flash LED are optically isolated.

[0102] The first radiation source 11 may emit through the opening 61 or through the additional opening.

[0103] The optical crosstalk is improved compared to single emitter/receiver solutions. The optical path through the human body can be increased. Thus, a better signal-to-noise ratio is achieved, wherein the noise includes human movement.

[0104] Figures 3C and 3D show the operation performed by the user of the biometric sensor arrangement 10 that can be realized as illustrated in one of the Figures 1A to 1G, 2A to 2D, 3A and 3B. A short light pulse emitted by the second radiation source 12 shows the user the place where the user has to put his finger 63, as illustrated by Figure 3C. When the user has put his finger 63 on the right place, as shown in Figure 3D, the biometric sensor arrangement 10 is able to perform the determination of the biometric signal SB and, thus, determines the pulse rate. Advantageously, the driver 13 is realized as a Flash LED Driver and can also be used as a heart rate sensor.

[0105] Figure 3E shows an exemplary embodiment of a mobile device comprising the biometric sensor arrangement 10 that can be realized as illustrated in one of the above shown Figures. The mobile device is realized as a watch 70. The watch 70 comprises the biometric sensor arrangement 10. The watch 70 can also be called wrist watch. The biometric sensor arrangement 10 is located at a backside of the watch 70 such that the watch 70 is in direct contact to an arm of the user.

[0106] The invention is defined by appended claims 1-12.

Reference Numerals

[0107]

10	biometric sensor arrangement
11	first radiation source
12	second radiation source
13	driver
14	first driver terminal
15	second driver terminal
16	photosensor
17	photodiode
18	signal conditioning unit
19	logic circuit
20	I2C interface

21	further signal terminals
22	supply terminal
23	reference potential terminal
24	converter
25	switch
26	current source
27	further current source
28	control unit
29	converter controller
30	inductor
31	first converter switch
32	second converter switch
33	output capacitor
34	input capacitor
35	semiconductor substrate
36	further semiconductor substrate
37	transimpedance amplifier
38	operational amplifier
39	feedback resistor
40	feedback capacitor
41	filter
42	analog-to-digital converter
43	calculation unit
44	further supply terminal
45	further reference potential terminal
46	synchronization connection line
47	synchronization pin
48	data connection line
49	converter capacitor
55	skin
56	epidermis layer
57	hypodermis layer
58	capillaries
59	mobile telecommunication device
60	housing
61	opening
62	further opening
63	finger
64	camera
70	watch
A	first operating phase
B	second operating phase
B1	first converter phase
B2	second converter phase
B3	flash operating phase
GND	reference potential
IL	inductor current
INT	further signal
I1	first current
I2	second current
SB	biometric signal
SCL, SDA I2C	signals
SP, SP'	photon signal
STR	further signal
TXM	further signal
VBAT	battery voltage
VDC	converter voltage
VOU	output voltage

Claims

1. Biometric sensor arrangement, comprising:

- 5 - a first radiation source (11),
 - a second radiation source (12) that is implemented as a flash radiation source, wherein the second radiation source (12) is realized as flash LED,
 10 - a driver (13) coupled to the first and the second radiation source (11, 12),
 - a photosensor (16) and
 - a signal conditioning unit (18) coupled to the photosensor (16) and designed to provide a biometric signal (SB),
 15

characterized in

that the flash LED is implemented as white LED and is fabricated for conducting a high current that is higher than 500 mA,

wherein the driver (13) is configured to selectively operate the first and the second radiation source (11, 12) and is configured to operate the first radiation source (11) in a first operating phase (A) and to operate the second radiation source (12) in a second operating phase (B) such that the second radiation source (12) emits a flash in the second operating phase (B), and

wherein the signal conditioning unit (18) is configured to provide the biometric signal (SB) depending on a photon signal (SP) generated by the photosensor (16) in the first operating phase (A) and independent from the photon signal (SB) in the second operating phase (B).

2. Biometric sensor arrangement according to Claim 1, wherein the photosensor (16) is configured to provide the photon signal (SP) as a function of radiation emitted by the first radiation source (11).

3. Biometric sensor arrangement according to Claim 1 or 2, wherein the first radiation source (11) is configured to emit radiation at a first wavelength and the second radiation source (12) is configured to emit radiation at a second wavelength that is different from the first wavelength.

4. Biometric sensor arrangement according to one of Claims 1 to 3, wherein the first radiation source (11) is realized as light-emitting diode, LED, and the first and the second radiation source (11, 12) form an anti-parallel circuit of diodes.

5. Biometric sensor arrangement according to Claim 4, wherein the driver (13) is implemented as a H-bridge that is configured to supply the first and the second

radiation source (11, 12).

6. Biometric sensor arrangement according to Claim 4, wherein the driver (13) comprises a current source (26), a further current source (27) and a converter (24), and wherein the further current source (27) couples a supply terminal (22) to a first driver terminal (14), the current source (26) couples an output of the converter (24) to the first driver terminal (14) and the first driver terminal (14) is coupled to a terminal of the first radiation source (11) and to a terminal of the second radiation source (12). 5
7. Biometric sensor arrangement according to one of Claims 4 to 6, wherein the first radiation source (11) is configured to protect the second radiation source (12) in an event of an electrostatic discharge. 10
8. Biometric sensor arrangement according to one of Claims 1 to 7, wherein the first and the second radiation source (11, 12) are arranged in vicinity and are configured to emit radiation through the same opening (61) of a housing (60). 15
9. Biometric sensor arrangement according to one of Claims 1 to 8, wherein the biometric sensor arrangement (10) is configured to determine a heart rate of a user. 20
10. Biometric sensor arrangement according to one of Claims 1 to 9, wherein the biometric sensor arrangement (10) is configured to determine the concentration of at least one parameter in a skin of a user of a group consisting of melanin, water, fat, alcohol and oxygen. 25
11. Mobile device, comprising the biometric sensor arrangement (10) according to one of Claims 1 to 10, wherein the mobile device is realized as a mobile telecommunication device (59) or a watch (70). 30
12. Method for generating a biometric signal, comprising: 35
- operating a first and a second radiation source (11, 12) by a driver (13), wherein the second radiation source (12) is implemented as a flash radiation source and is realized as flash LED, 40
 - providing a photon signal (SP) by a photosensor (16) as a function of radiation emitted by the first radiation source (11) and 45
 - providing the biometric signal (SB) by a signal conditioning unit (18) as a function of the photon signal (SP), 50

characterized in

that the flash LED is implemented as white LED and is fabricated for conducting a high current that is higher than 500 mA, wherein the driver (13) selectively operates the first and the second radiation source (11, 12), wherein the driver (13) is configured to operate the first radiation source (11) in a first operating phase (A) and to operate the second radiation source (12) in a second operating phase (B) such that the second radiation source (12) emits a flash in the second operating phase (B), and wherein the signal conditioning unit (18) is configured to provide the biometric signal (SB) depending on the photon signal (SP) generated by the photosensor (16) in the first operating phase (A) and independent from the photon signal (SB) in the second operating phase (B).

20 Patentansprüche

1. Biometrische Sensoranordnung, aufweisend:

- eine erste Strahlungsquelle (11),
- eine zweite Strahlungsquelle (12), die als Blitzstrahlungsquelle ausgebildet ist, wobei die zweite Strahlungsquelle (12) als Blitz-LED ausgeführt ist,
- einen Treiber (13), der mit der ersten und zweiten Strahlungsquelle (11, 12) verbunden ist,
- einen Lichtsensor (16) und
- eine Signalaufbereitungseinheit (18), die mit dem Lichtsensor (16) verbunden und zum Bereitstellen eines biometrischen Signals (SB) ausgelegt ist,

dadurch gekennzeichnet, dass

die Blitz-LED als weiße LED ausgeführt und für die Durchleitung eines hohen Stroms von über 500 mA konfektioniert ist, wobei der Treiber (13) dazu ausgelegt ist, die erste und zweite Strahlungsquelle (11, 12) selektiv zu betreiben, und dazu ausgelegt ist, die erste Strahlungsquelle (11) in einer ersten Betriebsphase (A) und die zweite Strahlungsquelle (12) in einer zweiten Betriebsphase (B) so zu betreiben, dass die zweite Strahlungsquelle (12) in der zweiten Betriebsphase (B) einen Blitz aussendet, und wobei die Signalaufbereitungseinheit (18) dazu ausgelegt ist, das biometrische Signal (SB) in der ersten Betriebsphase (A) in Abhängigkeit von einem vom Lichtsensor (16) erzeugten Photonensignal (SP) und in der zweiten Betriebsphase (B) unabhängig vom Photonensignal (SP) bereitzustellen.

2. Biometrische Sensoranordnung nach Anspruch 1, wobei der Lichtsensor (16) dazu ausgelegt ist, das Photonensignal (SP) abhängig von der von der ers-

- ten Strahlungsquelle (11) emittierten Strahlung bereitstellen.
3. Biometrische Sensoranordnung nach Anspruch 1 oder 2, wobei die erste Strahlungsquelle (11) dazu ausgelegt ist, Strahlung mit einer ersten Wellenlänge zu emittieren, und die zweite Strahlungsquelle (12) dazu ausgelegt ist, Strahlung mit einer zweiten Wellenlänge zu emittieren, die sich von der ersten Wellenlänge unterscheidet. 5
 4. Biometrische Sensoranordnung nach einem der Ansprüche 1 bis 3, wobei die erste Strahlungsquelle (11) als lichtemittierende Diode, LED, ausgeführt ist, und die erste und zweite Strahlungsquelle (11, 12) eine antiparallele Schaltung aus Dioden bilden. 10
 5. Biometrische Sensoranordnung nach Anspruch 4, wobei der Treiber (13) als H-Brücke ausgeführt ist, die zur Versorgung der ersten und zweiten Strahlungsquelle (11, 12) ausgelegt ist. 15
 6. Biometrische Sensoranordnung nach Anspruch 4, wobei der Treiber (13) eine Stromquelle (26), eine weitere Stromquelle (27) und einen Wandler (24) aufweist, und wobei die weitere Stromquelle (27) einen Versorgungsanschluss (22) mit einem ersten Treiberanschluss (14) verbindet, die Stromquelle (26) einen Ausgang des Wandlers (24) mit dem ersten Treiberanschluss (14) verbindet, und der erste Treiberanschluss (14) mit einem Anschluss der ersten Strahlungsquelle (11) und einem Anschluss der zweiten Strahlungsquelle (12) verbunden ist. 20
 7. Biometrische Sensoranordnung nach einem der Ansprüche 4 bis 6, wobei die erste Strahlungsquelle (11) dazu ausgelegt ist, die zweite Strahlungsquelle (12) im Falle einer elektrostatischen Entladung zu schützen. 25
 8. Biometrische Sensoranordnung nach einem der Ansprüche 1 bis 7, wobei die erste und zweite Strahlungsquelle (11, 12) nahe beieinander liegen und dazu ausgelegt sind, Strahlung durch dieselbe Öffnung (61) eines Gehäuses (60) abzugeben. 30
 9. Biometrische Sensoranordnung nach einem der Ansprüche 1 bis 8, wobei die biometrische Sensoranordnung (10) dazu ausgelegt ist, eine Herzfrequenz eines Benutzers zu bestimmen. 35
 10. Biometrische Sensoranordnung nach einem der Ansprüche 1 bis 9, wobei die biometrische Sensoranordnung (10) dazu ausgelegt ist, die Konzentration von mindestens einem Parameter in einer Haut eines Benutzers zu bestimmen, und zwar aus einer Gruppe bestehend aus Melanin, Wasser, Fett, Alkohol und Sauerstoff. 40
 11. Mobile Vorrichtung, umfassend die biometrische Sensoranordnung (10) nach einem der Ansprüche 1 bis 10, wobei die mobile Vorrichtung als mobile Telekommunikationsvorrichtung (59) oder Uhr (70) ausgeführt ist. 45
 12. Verfahren zum Erzeugen eines biometrischen Signals, umfassend:
 - Betreiben einer ersten und einer zweiten Strahlungsquelle (11, 12) durch einen Treiber (13), wobei die zweite Strahlungsquelle (12) als Blitzstrahlungsquelle realisiert und als Blitz-LED ausgeführt ist,
 - Bereitstellen eines Photonensignals (SP) durch einen Lichtsensor (16) in Abhängigkeit von der von der ersten Strahlungsquelle (11) emittierten Strahlung und
 - Bereitstellen des biometrischen Signals (SB) durch eine Signalaufbereitungseinheit (18) in Abhängigkeit vom Photonensignal (SP),

dadurch gekennzeichnet, dass
 die Blitz-LED als weiße LED ausgeführt und für die Durchleitung eines hohen Stroms von über 500 mA konfektioniert ist, wobei der Treiber (13) die erste und zweite Strahlungsquelle (11, 12) selektiv betreibt, wobei der Treiber (13) dazu ausgelegt ist, die erste Strahlungsquelle (11) in einer ersten Betriebsphase (A) und die zweite Strahlungsquelle (12) in einer zweiten Betriebsphase (B) so zu betreiben, dass die zweite Strahlungsquelle (12) in der zweiten Betriebsphase (B) einen Blitz aussendet, und wobei die Signalaufbereitungseinheit (18) dazu ausgelegt ist, das biometrische Signal (SB) in der ersten Betriebsphase (A) in Abhängigkeit von dem vom Lichtsensor (16) erzeugten Photonensignal (SP) und in der zweiten Betriebsphase (B) unabhängig vom Photonensignal (SP) bereitzustellen. 50

Revendications

1. Agencement de capteur biométrique, comprenant :
 - une première source de rayonnement (11),
 - une deuxième source de rayonnement (12) qui est implémentée comme source de rayonnement éclair, sachant que la deuxième source de rayonnement (12) est réalisée comme LED éclair,

- un pilote (13) couplé à la première et à la deuxième source de rayonnement (11, 12),
- un photocapteur (16) et
- une unité de traitement de signal (18) couplée au photocapteur (16) et conçue pour fournir un signal biométrique (SB),

caractérisé en ce que

la LED éclair est implémentée comme LED blanche et est fabriquée pour conduire un courant fort qui est supérieur à 500 mA,

sachant que le pilote (13) est configuré pour faire fonctionner sélectivement la première et la deuxième source de rayonnement (11, 12) et est configuré pour faire fonctionner la première source de rayonnement (11) dans une première phase de fonctionnement (A) et pour faire fonctionner la deuxième source de rayonnement (12) dans une deuxième phase de fonctionnement (B) de sorte que la deuxième source de rayonnement (12) émette un éclair dans la deuxième phase de fonctionnement (B), et sachant que l'unité de traitement de signal (18) est configurée pour fournir le signal biométrique (SB) en fonction d'un signal de photon (SP) généré par le photocapteur (16) dans la première phase de fonctionnement (A) et indépendamment du signal de photon (SB) dans la deuxième phase de fonctionnement (B).

2. Agencement de capteur biométrique selon la revendication 1, sachant que le photocapteur (16) est configuré pour fournir le signal de photon (SP) comme fonction d'un rayonnement émis par la première source de rayonnement (11).
3. Agencement de capteur biométrique selon la revendication 1 ou 2, sachant que la première source de rayonnement (11) est configurée pour émettre un rayonnement à une première longueur d'onde et la deuxième source de rayonnement (12) est configurée pour émettre un rayonnement à une deuxième longueur d'onde qui est différente de la première longueur d'onde.
4. Agencement de capteur biométrique selon l'une des revendications 1 à 3, sachant que la première source de rayonnement (11) est réalisée comme diode électroluminescente, LED, et la première et la deuxième source de rayonnement (11, 12) forment un circuit antiparallèle de diodes.
5. Agencement de capteur biométrique selon la revendication 4, sachant que le pilote (13) est implémenté comme pont en H qui est configuré pour alimenter la première et la deuxième source de rayonnement (11, 12).

6. Agencement de capteur biométrique selon la revendication 4, sachant que le pilote (13) comprend une source de courant (26), une source de courant supplémentaire (27) et un convertisseur (24), et sachant que la source de courant supplémentaire (27) couple une borne d'alimentation (22) à une première borne de pilote (14), la source de courant (26) couple une sortie du convertisseur (24) à la première borne de pilote (14) et la première borne de pilote (14) est couplée à une borne de la première source de rayonnement (11) et à une borne de la deuxième source de rayonnement (12).
7. Agencement de capteur biométrique selon l'une des revendications 4 à 6, sachant que la première source de rayonnement (11) est configurée pour protéger la deuxième source de rayonnement (12) en cas de décharge électrostatique.
8. Agencement de capteur biométrique selon l'une des revendications 1 à 7, sachant que la première et la deuxième source de rayonnement (11, 12) sont agencées à proximité et sont configurées pour émettre un rayonnement à travers la même ouverture (61) d'un boîtier (60).
9. Agencement de capteur biométrique selon l'une des revendications 1 à 8, sachant que l'agencement de capteur biométrique (10) est configuré pour déterminer une fréquence cardiaque d'un utilisateur.
10. Agencement de capteur biométrique selon l'une des revendications 1 à 9, sachant que l'agencement de capteur biométrique (10) est configuré pour déterminer la concentration d'au moins un paramètre dans une peau d'un utilisateur d'un groupe constitué par la mélanine, l'eau, la graisse, l'alcool et l'oxygène.
11. Dispositif mobile, comprenant l'agencement de capteur biométrique (10) selon l'une des revendications 1 à 10, sachant que le dispositif mobile est réalisé comme dispositif de télécommunication mobile (59) ou comme montre (70).
12. Procédé de génération d'un signal biométrique, comprenant :
 - la mise en fonctionnement d'une première et d'une deuxième source de rayonnement (11, 12) par un pilote (13), sachant que la deuxième source de rayonnement (12) est implémentée comme source de rayonnement éclair et est réalisée comme LED éclair,

- la fourniture d'un signal de photon (SP) par un photodétecteur (16) comme fonction d'un rayonnement émis par la première source de rayonnement (11) et
- la fourniture du signal biométrique (SB) par une unité de traitement de signal (18) comme fonction du signal de photon (SP),

caractérisé en ce que

la LED éclair est implémentée comme LED blanche et est fabriquée pour conduire un courant fort qui est supérieur à 500 mA, sachant que le pilote (13) fait fonctionner sélectivement la première et la deuxième source de rayonnement (11, 12), sachant que le pilote (13) est configuré pour faire fonctionner la première source de rayonnement (11) dans une première phase de fonctionnement (A) et pour faire fonctionner la deuxième source de rayonnement (12) dans une deuxième phase de fonctionnement (B) de sorte que la deuxième source de rayonnement (12) émette un éclair dans la deuxième phase de fonctionnement (B), et sachant que l'unité de traitement de signal (18) est configurée pour fournir le signal biométrique (SB) en fonction du signal de photon (SP) généré par le photodétecteur (16) dans la première phase de fonctionnement (A) et indépendamment du signal de photon (SB) dans la deuxième phase de fonctionnement (B).

5

10

15

20

25

30

35

40

45

50

55

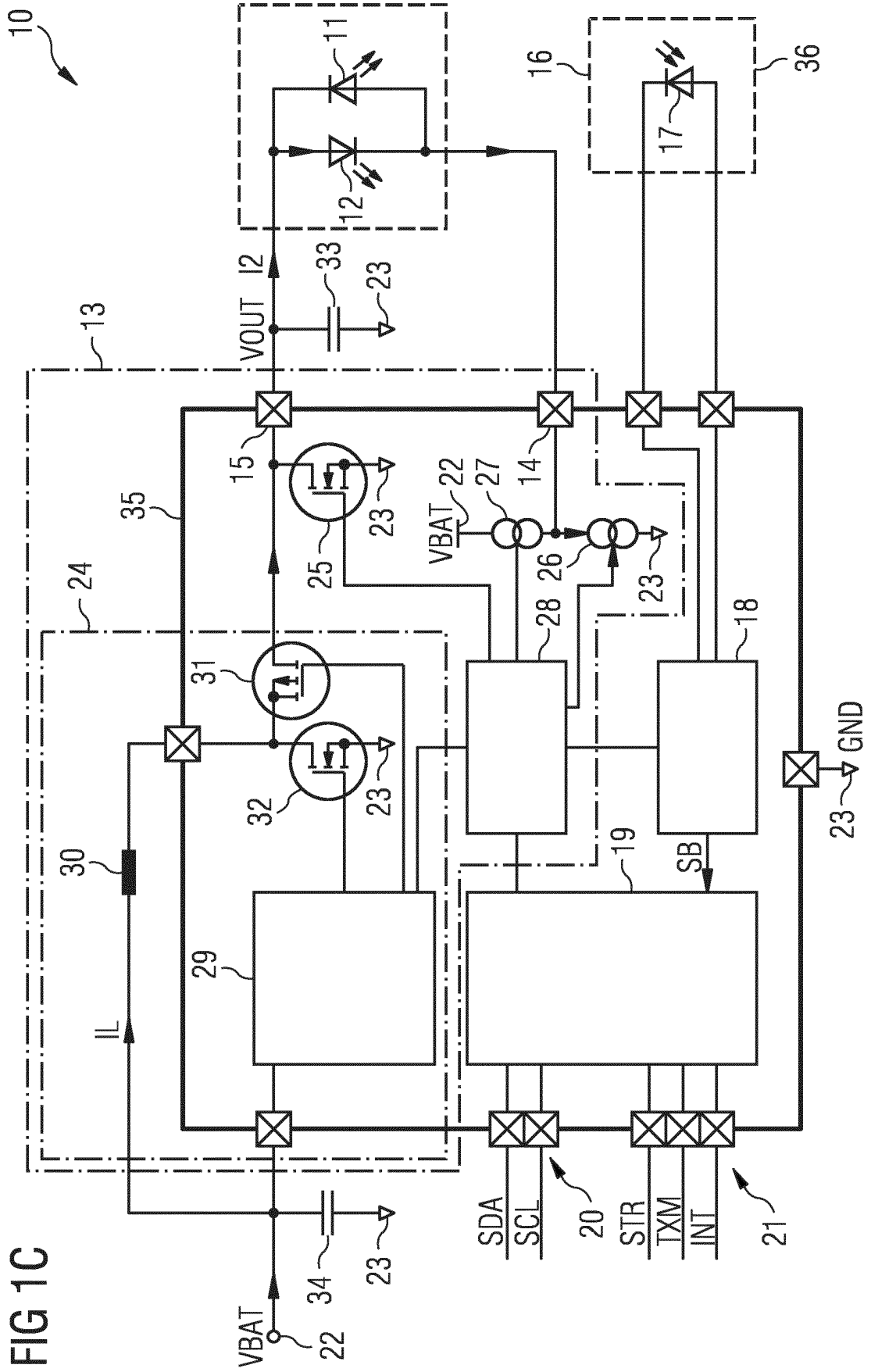

FIG 1D

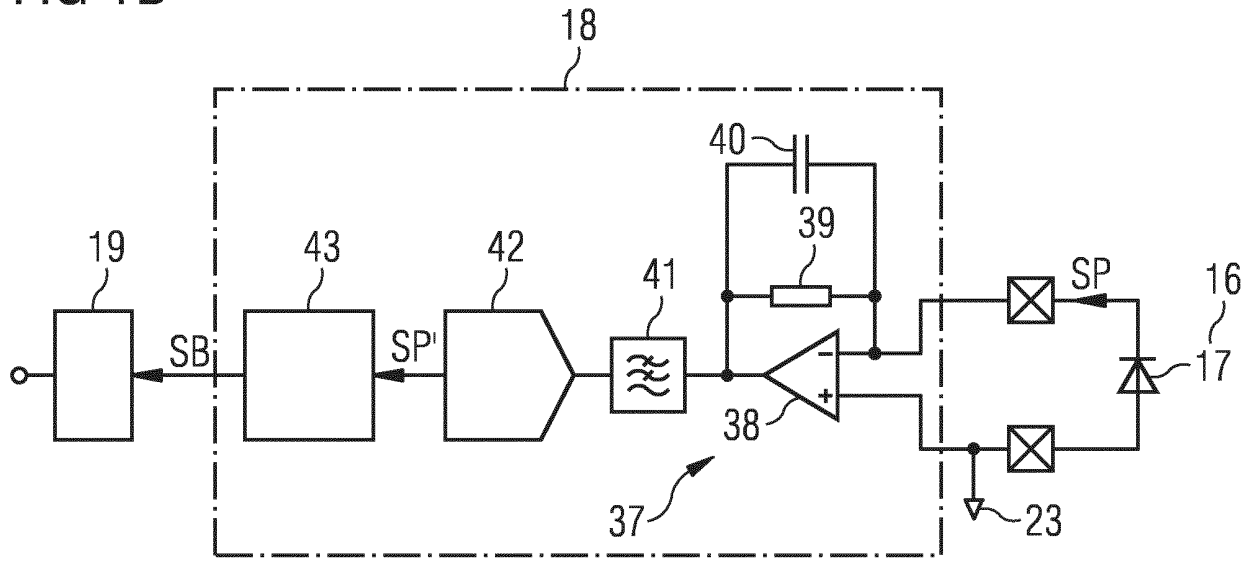
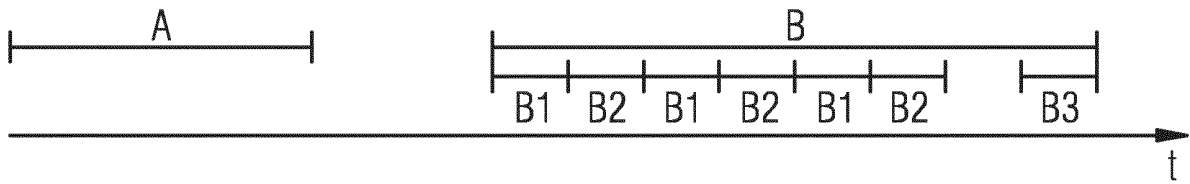
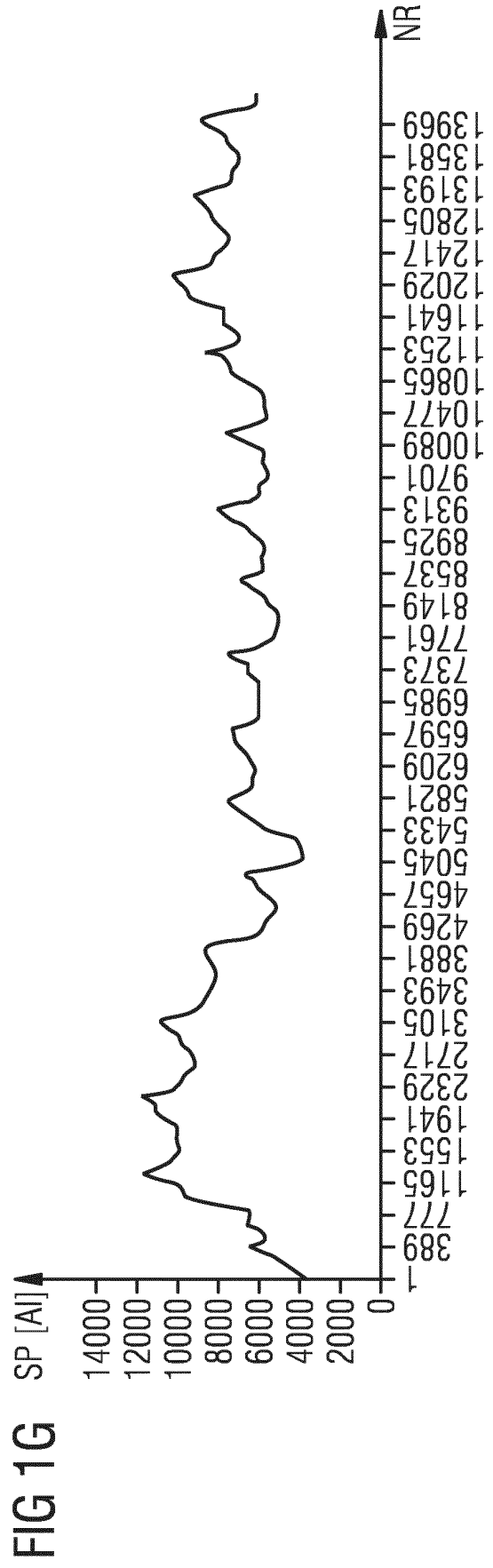
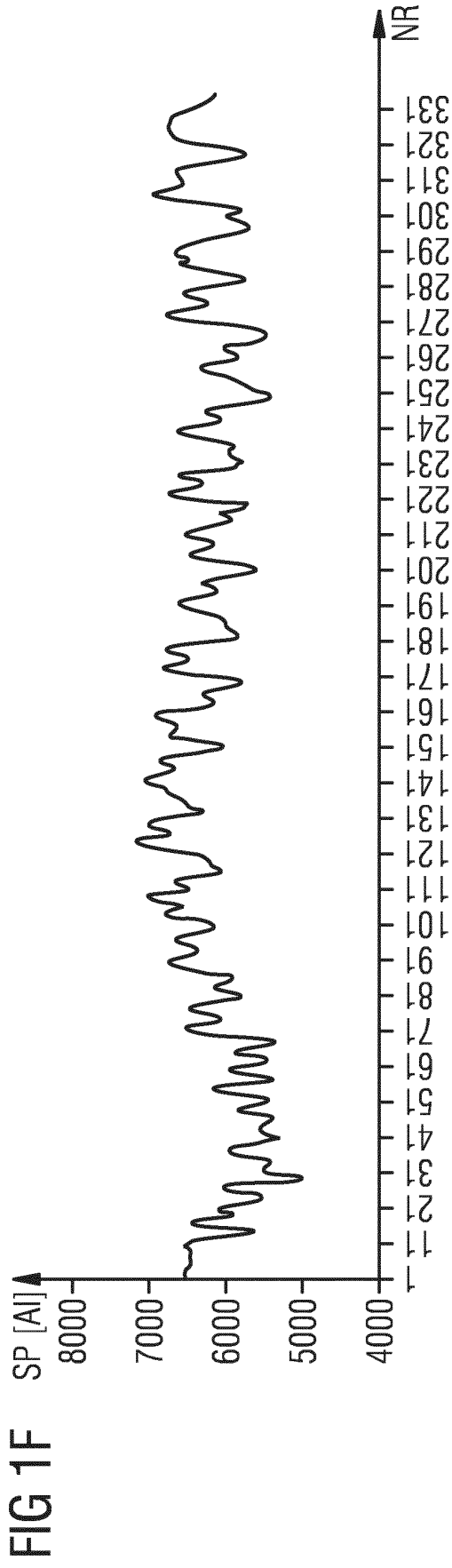
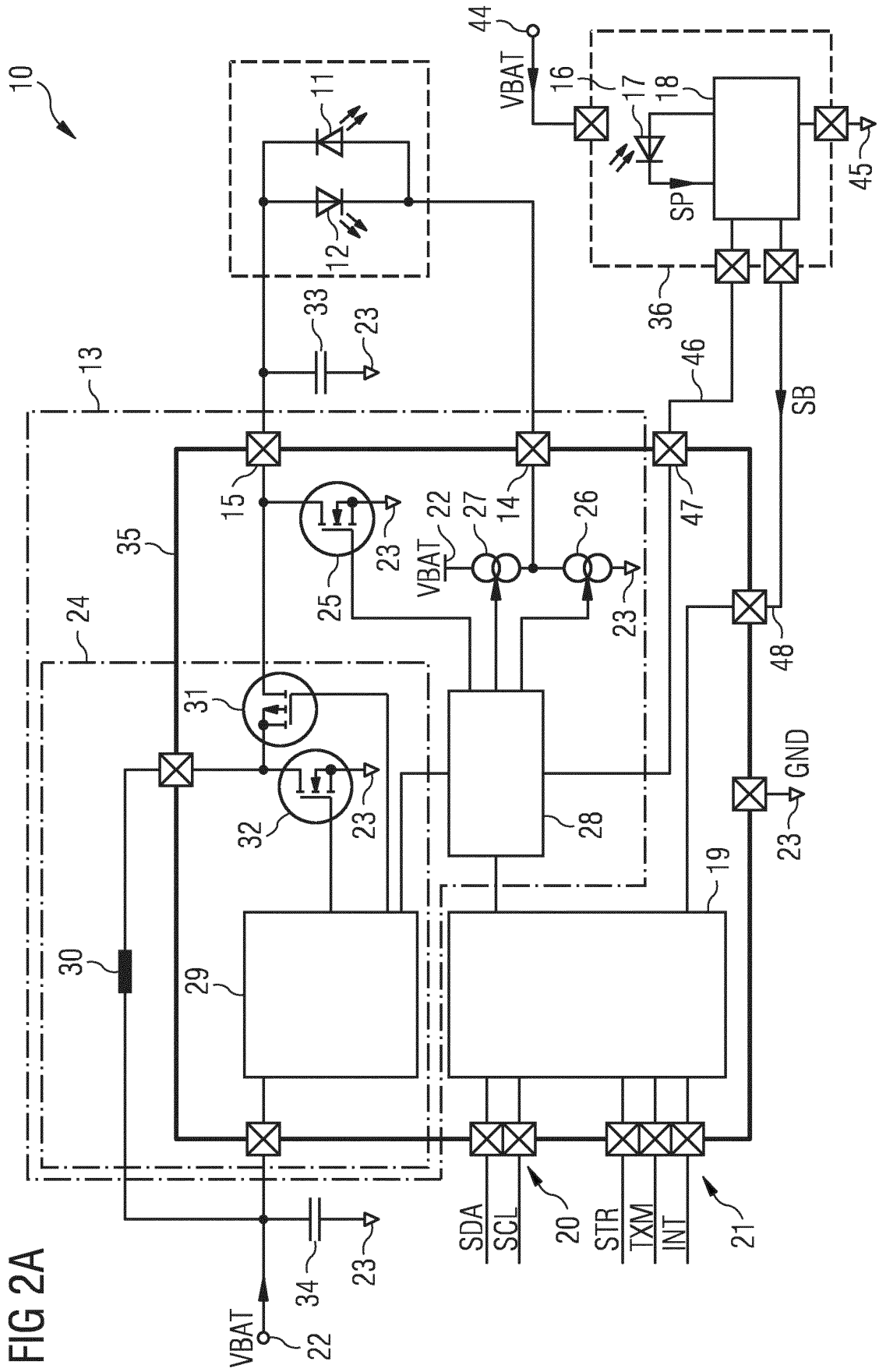
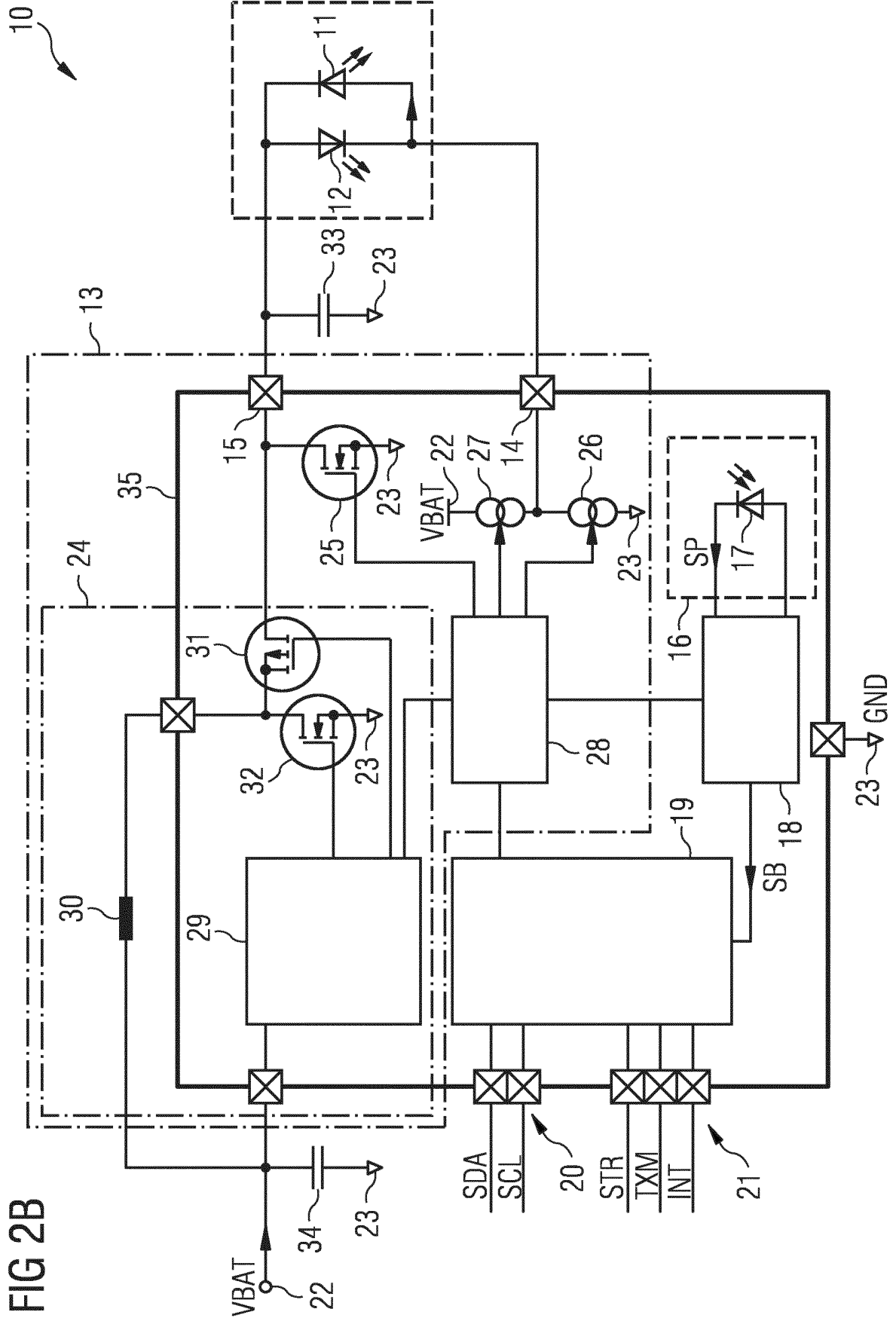

FIG 1E









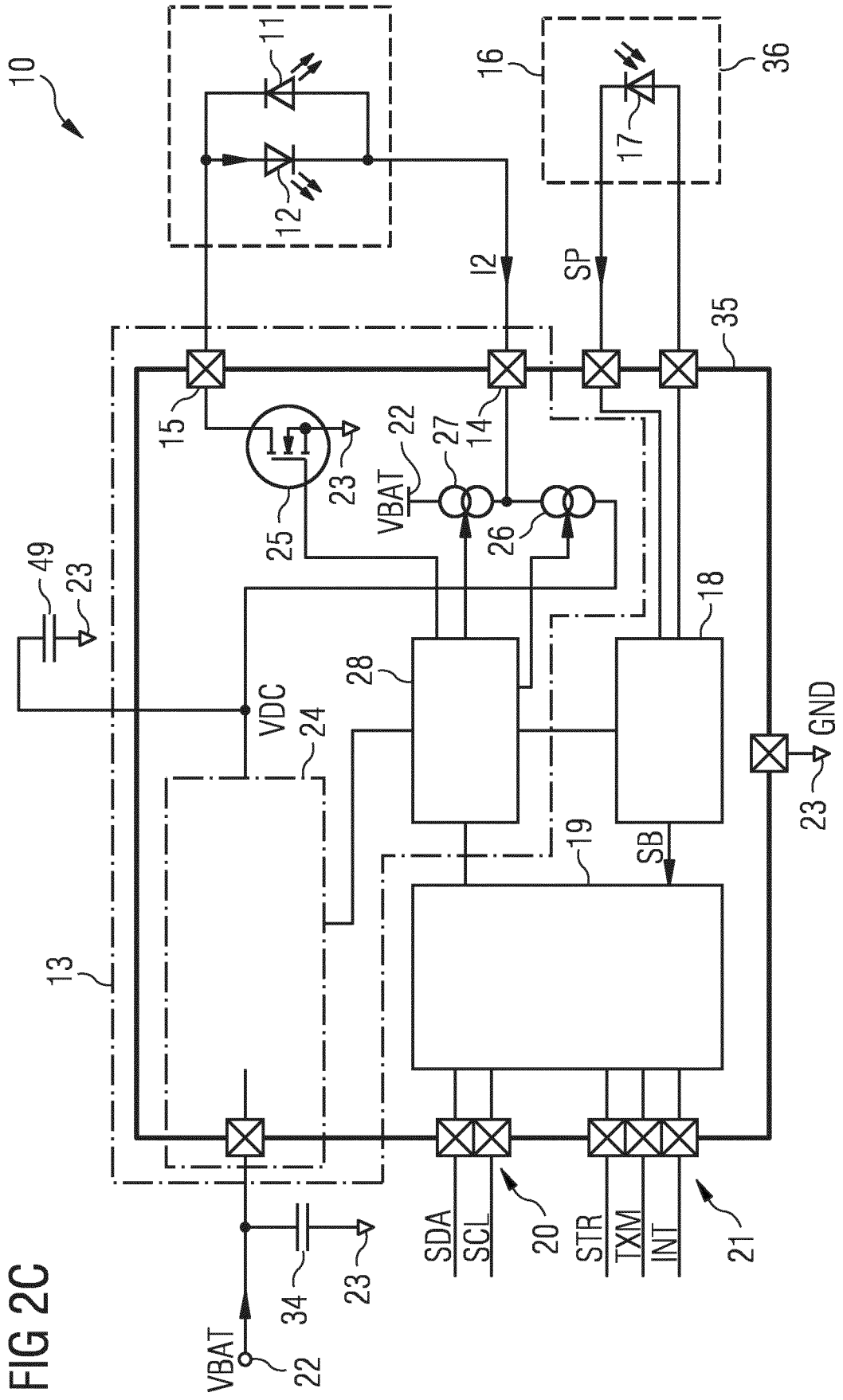

FIG 2C

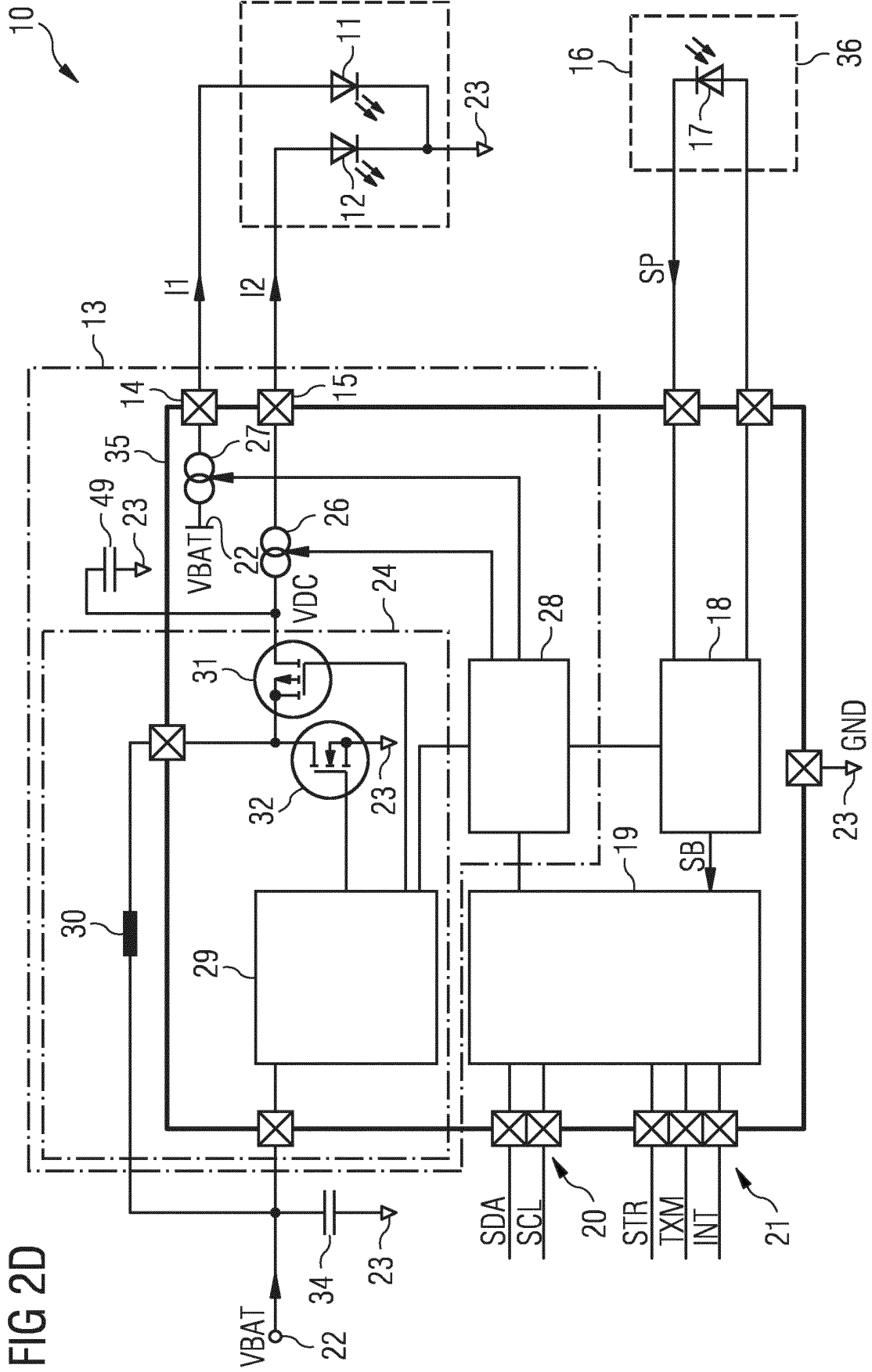

FIG 3A

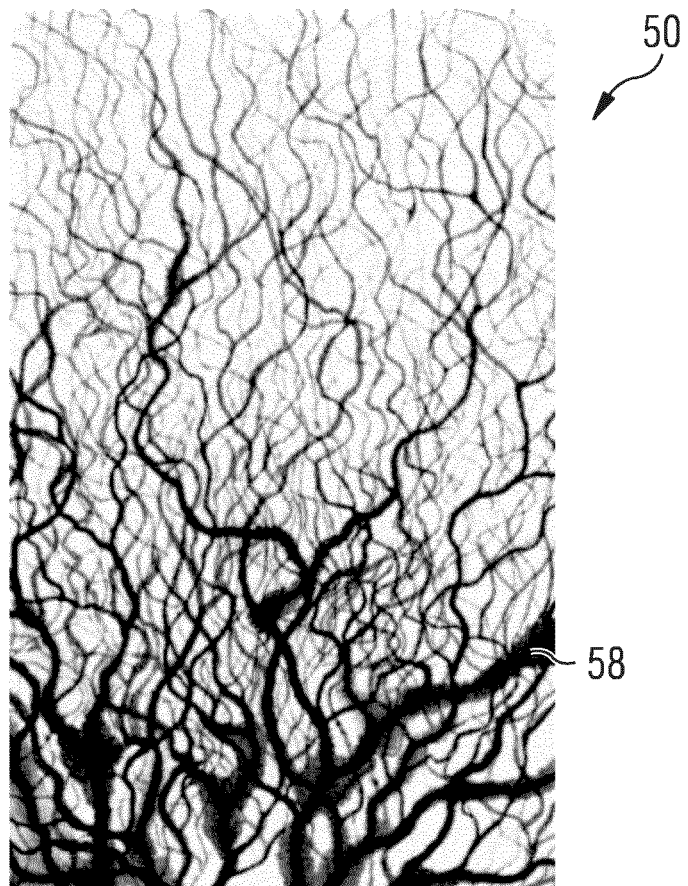
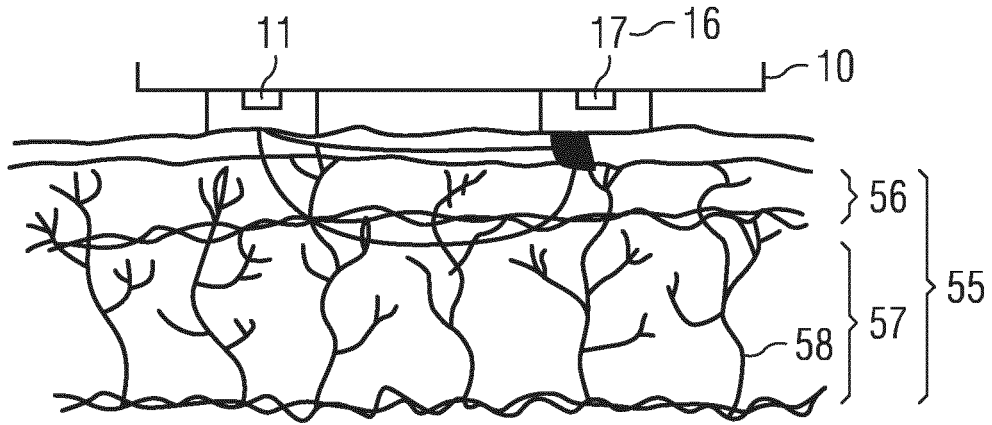

FIG 3B

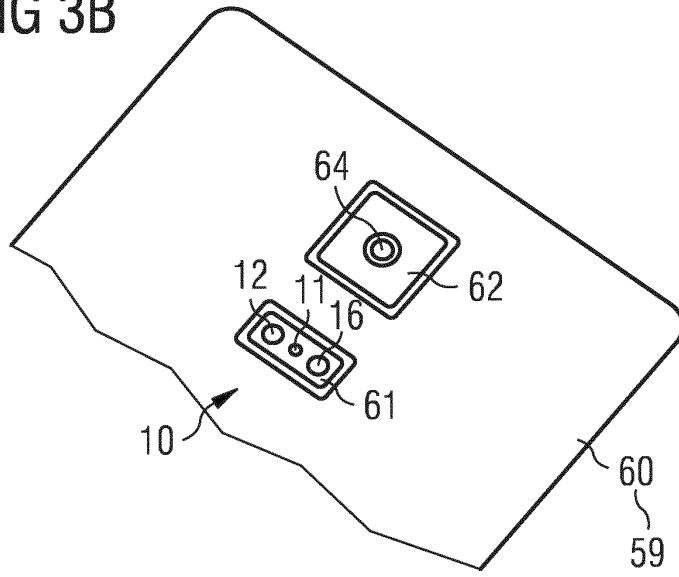

FIG 3C

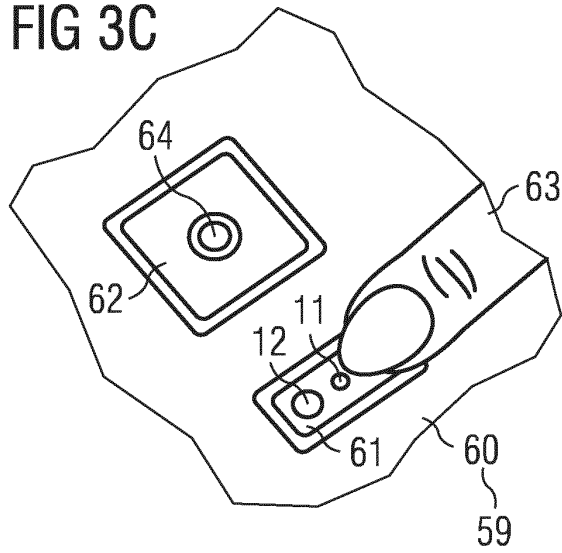

FIG 3D

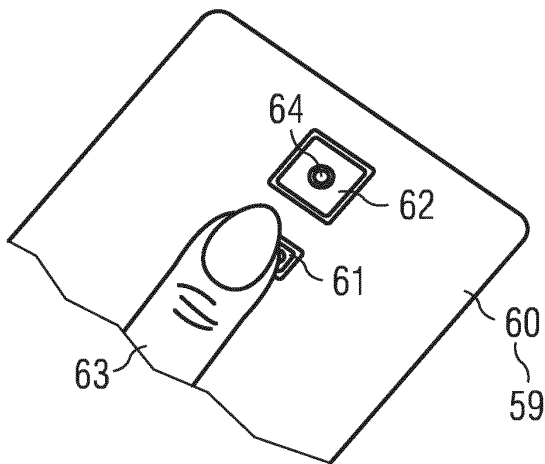
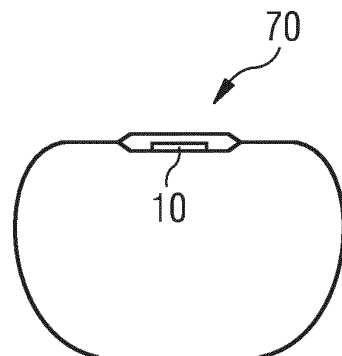

FIG 3E



REFERENCES CITED IN THE DESCRIPTION

This list of references cited by the applicant is for the reader's convenience only. It does not form part of the European patent document. Even though great care has been taken in compiling the references, errors or omissions cannot be excluded and the EPO disclaims all liability in this regard.

Patent documents cited in the description

- US 20050075553 A1 [0003]
- US 20150133756 A1 [0004]
- US 20150190094 A1 [0005]

专利名称(译)	生物特征传感器布置和用于生成生物特征信号的方法		
公开(公告)号	EP3123937B1	公开(公告)日	2019-08-28
申请号	EP2015178625	申请日	2015-07-28
[标]申请(专利权)人(译)	奥地利微系统股份有限公司		
申请(专利权)人(译)	AMS AG		
当前申请(专利权)人(译)	AMS AG		
[标]发明人	ENENKEL JAN		
发明人	ENENKEL, JAN		
IPC分类号	A61B5/024 A61B5/1455 A61B10/00 A61B5/00 H05B33/08		
其他公开文献	EP3123937A1		
外部链接	Espacenet		

摘要(译)

生物识别传感器装置 (10) 包括第一辐射源 (11)，实现为闪光辐射源的第二辐射源 (12) 和耦合到第一和第二辐射源 (11,12) 的驱动器 (13)。并且配置成选择性地操作第一和第二辐射源 (11,12)。此外，生物传感器装置 (10) 包括光电传感器 (16) 和耦合到光电传感器 (16) 并设计成提供生物信号 (SB) 的信号调节单元 (18)。

