

(19)



(11)

EP 3 064 128 B1

(12)

EUROPEAN PATENT SPECIFICATION

(45) Date of publication and mention of the grant of the patent:
23.10.2019 Bulletin 2019/43

(51) Int Cl.:
A61B 5/024 ^(2006.01) **A61B 5/1455** ^(2006.01)
A61B 5/00 ^(2006.01)

(21) Application number: **15157297.1**

(22) Date of filing: **03.03.2015**

(54) USER WEARABLE APPARATUS WITH OPTICAL SENSOR

VOM BENUTZER TRAGBARE VORRICHTUNG MIT OPTISCHEM SENSOR

APPAREIL PORTABLE PAR UN UTILISATEUR AVEC CAPTEUR OPTIQUE

(84) Designated Contracting States:
AL AT BE BG CH CY CZ DE DK EE ES FI FR GB GR HR HU IE IS IT LI LT LU LV MC MK MT NL NO PL PT RO RS SE SI SK SM TR

(43) Date of publication of application:
07.09.2016 Bulletin 2016/36

(73) Proprietor: **Nokia Technologies Oy**
02610 Espoo (FI)

(72) Inventors:
• **Rouvinen, Jarkko**
02340 Espoo (FI)

• **Kosonen, Matti**
04420 Järvenpää (FI)

(74) Representative: **Espatent Oy**
Kaivokatu 10 D
00100 Helsinki (FI)

(56) References cited:
EP-A1- 3 026 523 **WO-A2-2006/067690**
US-A- 5 238 000 **US-A1- 2014 275 854**
US-A1- 2015 038 853

EP 3 064 128 B1

Note: Within nine months of the publication of the mention of the grant of the European patent in the European Patent Bulletin, any person may give notice to the European Patent Office of opposition to that patent, in accordance with the Implementing Regulations. Notice of opposition shall not be deemed to have been filed until the opposition fee has been paid. (Art. 99(1) European Patent Convention).

Description**TECHNICAL FIELD**

[0001] The present application generally relates to user wearable sensor apparatuses and especially to optical sensor arrangements therein.

BACKGROUND

[0002] This section illustrates useful background information without admission of any technique described herein representative of the state of the art.

[0003] Various metering devices such as pulse sensors have become more common for people to measure their own heart rate, movements or other parameters.

[0004] Pulse or heart rate measurement can be performed using a chest strap that is worn under clothes and maintains electric cardiac sensor's sensor in place on the skin of the user so that heart beat can be computed from the signals produced by the sensor. Another alternative is a wrist worn watch-like pulse sensor, often combined with accelerometers for acting as pedometer.

[0005] In wrist worn sensors, heart rate can be monitored for example optically. Optical heart rate measurement requires that the sensor is kept very stably on the wrist during the measurement. However, a wrist strap cannot be kept too tight, because it would be inconvenient / unpleasant for the user and might even stop or deteriorate blood circulation in small vessels thereby causing the measurement signal to disappear. As you need to be moderate with tightening, the device will basically always move a bit and the measurement is affected.

Document US2014/275854 discloses an embodiment where motion of the optical device with respect to the skin may be tracked through feature-tracking of the skin and/or adaptive motion correction using an accelerometer and gyroscope.

SUMMARY

[0006] Various aspects of examples of the invention are set out in the claims.

[0007] According to a first example aspect of the present invention, there is provided a user wearable apparatus comprising:

an optical sensor structure configured to optically monitor an area of a body of a user wearing the apparatus to monitor a physiological property of the user, and
a processor configured

to cause movement of at least one part of the optical sensor structure to change the monitored area of the body of the user and to determine a desired monitoring area, wherein the movement of the at least one part of the optical sensor struc-

ture causes changes in optical path of light rays used in the optical sensor structure, wherein the desired monitoring area is an area where a measured signal is strongest or where the measured signal exceeds a threshold value, and to maintain the monitoring of the physiological property of the user at the determined desired monitoring area.

[0008] In an embodiment, the optical sensor structure comprises a light source configured to illuminate an area of the body of the user wearing the apparatus, and a detector configured to detect light rays reflected from the body of the user to monitor the physiological property of the user.

[0009] In an embodiment, the movement of the at least one part of the optical sensor structure causes changes in optical path of light rays used in the optical sensor structure.

[0010] In an embodiment, the movement of the at least one part of the optical sensor structure comprises movement of the whole optical sensor structure.

[0011] In an embodiment, the optical sensor structure comprises an actuator configured to move the at least one part of the optical sensor structure, and wherein the processor is configured to control the actuator to move the at least one part of the optical sensor structure.

[0012] In an embodiment, the at least one part of the optical sensor structure is moved laterally in relation to optical axis of the optical sensor structure.

[0013] In an embodiment, the movement of the at least one part of the optical sensor structure is movement of an internal structure of the at least one part of the optical sensor structure.

[0014] In an embodiment, the optical sensor structure comprises an optical emitter and emitter optics; and an optical detector and detector optics; and the actuator is configured to move at least one of: the optical emitter, the emitter optics, the optical detector, and the detector optics.

[0015] In an embodiment, the actuator is a stabilizer comprised in or operatively connected to a movable part of the optical sensor structure.

[0016] In an embodiment, the processor is configured to cause movement of the at least one part of the optical sensor structure to compensate for movements of the user wearable apparatus and to maintain the monitoring of the physiological property of the user at the determined desired monitoring area.

[0017] In an embodiment, the user wearable apparatus further comprises a motion detection sensor configured to detect movements of the user wearable apparatus in relation to the body of the user, and the processor is configured to determine, based on movements detected by the motion detection sensor, movement required for the at least one part of the optical sensor structure to compensate for the movements of the user wearable apparatus.

[0018] In an embodiment, the desired monitoring area is an area that fulfills certain predefined criteria.

[0019] In an embodiment, the physiological property is heart rate.

[0020] In an embodiment, the apparatus is one of: a wrist strap, an ankle strap, a device configured to be integrated into a garment of a user.

[0021] According to a second example aspect of the present invention, there is provided a method comprising:

using an optical sensor structure to optically monitor an area of a body of a user wearing a user wearable apparatus to monitor a physiological property of the user,
 moving at least one part of the optical sensor structure to change the monitored area of the body of the user and to determine a desired monitoring area, wherein the movement of the at least one part of the optical sensor structure causes changes in optical path of light rays used in the optical sensor structure, wherein the desired monitoring area is an area where a measured signal is strongest or where the measured signal exceeds a threshold value, and maintaining the monitoring of the physiological property of the user at the determined desired monitoring area.

[0022] In an embodiment, the method comprises moving the at least one part of the optical sensor structure to compensate for movements of the user wearable apparatus and to maintain the monitoring of the physiological property of the user at the determined desired monitoring area.

[0023] In an embodiment, the method further comprises detecting movements of the user wearable apparatus in relation to the body of the user, and determining, based on movements detected, movements required for the at least one part of the optical sensor structure to compensate for the movements of the user wearable apparatus.

[0024] In an example implementation, there is provided a computer program comprising computer executable program code configured to control a wearable device, when the computer executable program code is executed, to perform the method of the second aspect.

[0025] The computer program may be stored in a computer readable memory medium. The memory medium may be a non-transitory memory medium.

[0026] Any foregoing memory medium may comprise a digital data storage such as a data disc or diskette, optical storage, magnetic storage, holographic storage, opto-magnetic storage, phase-change memory, resistive random access memory, magnetic random access memory, solid-electrolyte memory, ferroelectric random access memory, organic memory or polymer memory. The memory medium may be formed into a device without other substantial functions than storing memory or it may be formed as part of a device with other functions, including but not limited to a memory of a computer, a chip set,

and a sub assembly of an electronic device.

[0027] Different non-binding example aspects and embodiments of the present invention have been illustrated in the foregoing. The embodiments in the foregoing are used merely to explain selected aspects or steps that may be utilized in implementations of the present invention. Some embodiments may be presented only with reference to certain example aspects of the invention. It should be appreciated that corresponding embodiments may apply to other example aspects as well.

BRIEF DESCRIPTION OF THE DRAWINGS

[0028] For a more complete understanding of example embodiments of the present invention, reference is now made to the following descriptions taken in connection with the accompanying drawings in which:

Fig. 1 is a simplified illustration of an example optical heart rate measurement;

Figs. 2A and 2B show schematic drawings of apparatuses of example embodiments;

Fig. 3A, 3B and 3C show schematic drawings of apparatuses of example embodiments;

Fig. 4 illustrates operation principle of an example embodiment;

Fig. 5 shows a block diagram of an apparatus of an example embodiment;

Fig. 6 shows a flow chart of a process of an example embodiment; and

Fig. 7 shows a flow chart of a process of another example embodiment.

DETAILED DESCRIPTION OF THE DRAWINGS

[0029] Example embodiments of the present invention and its potential advantages are understood by referring to Figs. 1 through 6 of the drawings. In this document, like reference signs denote like parts or steps.

[0030] In the following, various example embodiments are discussed in connection with heart rate monitoring. Various embodiments are however not necessarily limited to heart rate monitoring only. Instead some other physiological condition can be monitored instead or in addition to heart rate monitoring. Physiological conditions may include one or more of the following: heart rate, blood pressure, and CO₂ (carbon dioxide) level. Also other physiological condition measurements may apply.

[0031] Heart rate can be monitored optically by measuring variations in blood volume with a PPG (Photoplethymography) sensor. Fig. 1 is a simplified illustration of an example optical heart rate measurement. Fig. 1 shows a simple reflective type PPG sensor that comprises a LED (light emitting diode) 101 and a photo diode (light detector) 102. The LED (optical emitter, light source) 101 emits light and the detector 102 receives light rays reflected from a wrist 103 of a user. Such optical heart rate measurement requires that the sensor is kept

very stably on the wrist during the measurement. However, a wrist strap cannot be kept too tight, because it would be inconvenient / unpleasant for the user and might even stop or deteriorate blood circulation in small vessels thereby causing the measurement signal to disappear. As you need to be moderate with tightening, the device will basically always move a bit and the measurement is affected.

[0032] In an embodiment of the invention, a monitoring apparatus (such as a heart rate monitoring device) is arranged to alter or change optical path of light rays used in an optical sensor structure before the light rays hit a detector element of the optical sensor structure. In an embodiment, the changes in the optical path are caused by moving part of the optical sensor structure (without moving the whole apparatus). In general, the optical sensor structure of such monitoring apparatus comprises a light source configured to illuminate an area of the body of the user wearing the apparatus, and a detector configured to detect light rays reflected from the body of the user to monitor the physiological property of the user.

[0033] The monitoring apparatus monitors a certain area of a body of a user. In an embodiment, at least one (internal) part of the optical sensor structure is moved to different positions to find a desired monitoring area. The movements are internal movements that do not move the whole monitoring apparatus. In an embodiment, the optical path of light rays used in the optical sensor structure is changed to find a desired monitoring area. The desired monitoring area may for example fulfill certain predefined criteria and/or be an optimal monitoring area. In an example, an area where the measured signal is strongest or where the signal exceeds certain threshold value is searched for. The threshold may be for example such that exceeding the threshold fulfills quality requirements set for the measurement. When the desired monitoring area has been found, the measurements are locked to that area. Thereafter changes in optical path of light rays used in the optical sensor structure and/or internal movements of internal part(s) of the optical sensor structure may be used to compensate for movements of the monitoring apparatus in relation to the body of the user. In this way the measurements can be maintained at the desired monitoring area. This may improve the monitoring result.

[0034] The part of the optical sensor structure that is moved may be the detector, the optical elements of the sensor structure, or the light source elements of the sensor structure, or some other part whose movement alters the optical path of light rays used in the optical sensor structure. In an embodiment the whole optical sensor structure is moved to change the monitoring area.

[0035] There may be for example an actuator that causes the movements of the movable part of the optical sensor structure. The actuator may be a stabilizer comprised in or integrated into the part that is moved. The actuator may be an electromagnetic voice coil or a piezoelectric actuator, for example.

[0036] Figs. 2A and 2B show schematic drawings of apparatuses of example embodiments. The apparatus is a user wearable device that comprises a strap 202 that can be fitted around a wrist 201 of a user and a body 203.

[0037] In Fig 2A, the body 203 comprises an optical sensor structure comprising an optical emitter 210, emitter optics 212, detector 213 and detector optics 214. The optical sensor structure is configured to produce sensor signals corresponding to a property of the skin or underlying matter (capillaries and veins, for example). In the example of Fig. 2A the detector optics 214 comprises or is operatively connected to an actuator that is configured to move the detector optics 214 within the body 203 and the optical sensor structure. In an example one may define that the actuator causes the detector optics to move perpendicularly in relation to an optical axis of the detector optics to cause a change in optical path of light rays in the optical sensor structure. If the optical axis of the detector optics is denoted as z direction in three dimensional coordinates, the detector optics may move in x and y directions. In an example one may define that the actuator causes the detector optics to move laterally in relation to skin of the user wearing the apparatus to cause a change in optical path of light rays in the optical sensor structure. In an example embodiment the movement of the detector optics 214 is a movement within the detector optics, i.e. an internal movement of the movable component. For example if the detector optics comprises a shape-changing prism, the movement may be tilting of glass plates of the shape-changing prism.

[0038] Furthermore the body 203 comprises a motion detector 215. In addition, the body comprises a processor or some other processing unit (not shown) that is configured to control functionalities of the body and the optical sensor structure. The processor may process measurement values or sensor signals received from the motion detector and the optical sensor structure, and control the optical sensor structure accordingly. The processor may for example determine desired monitoring area for the optical sensor structure and/or maintain monitoring at the desired monitoring area. The processor may cause the actuator to move the detector optics to change monitoring area of the optical sensor structure in order to determine the desired monitoring area. Additionally, the processor may cause the actuator to move the detector optics to compensate for movements of the apparatus in order to maintain the monitoring at the desired monitoring area.

[0039] In an example embodiment the detector optics operates as an optical stabilizer in front of the detector 213. The detector optics/optical stabilizer may be any suitable lens element or a shape-changing prism, for example.

[0040] In Fig 2B, the body 203 comprises an optical sensor structure comprising an optical emitter 210, emitter optics 222, detector 213 and detector optics 314. The optical sensor structure is configured to produce sensor signals corresponding to a property of the skin or underlying matter (capillaries and veins, for example). In the

example of Fig. 2B the emitter optics 222 comprises or is operatively connected to an actuator that is configured to move the emitter optics 222 within the body 203 and the optical sensor structure. In an example one may define that the actuator causes the emitter optics to move perpendicularly in relation to an optical axis of the emitter optics to cause a change in optical path of light rays in the optical sensor structure. If the optical axis of the emitter optics is denoted as z direction in three dimensional coordinates, the emitter optics may move in x and y directions. In an example one may define that the actuator causes the emitter optics to move laterally in relation to skin of the user wearing the apparatus to cause a change in optical path of light rays in the optical sensor structure. In an example embodiment the movement of the emitter optics 222 is a movement within the emitter optics. For example if the emitter optics comprises a shape-changing prism, the movement may be tilting of glass plates of the shape-changing prism.

[0041] Furthermore the body 203 comprises a motion detector 215. In addition, the body comprises a processor or some other processing unit (not shown) that is configured to control functionalities of the body and the optical sensor structure. The processor may process measurement values or sensor signals received from the motion detector and the optical sensor structure, and control the optical sensor structure accordingly. The processor may for example determine desired monitoring area for the optical sensor structure and/or maintain monitoring at the desired monitoring area. The processor may cause the actuator to move the emitter optics to change monitoring area of the optical sensor structure in order to determine the desired monitoring area. Additionally, the processor may cause the actuator to move the emitter optics to compensate for movements of the apparatus in order to maintain the monitoring at the desired monitoring area.

[0042] In an example embodiment the emitter optics operates as an optical stabilizer in front of the emitter 210. The emitter optics/optical stabilizer may be any suitable lens element or a shape-changing prism, for example.

[0043] Figs. 3A, 3B and 3C show schematic drawings of apparatuses of example embodiments. The apparatus is a user wearable device that comprises a strap 202 that can be fitted around a wrist 201 of a user and a body 203.

[0044] In Fig 3A, the body 203 comprises an optical sensor structure comprising an optical emitter 210, emitter optics 212, detector 313 and detector optics 314. The optical sensor structure is configured to produce sensor signals corresponding to a property of the skin or underlying matter (capillaries and veins, for example). In the example of Fig. 3 the detector 313 comprises or is operatively connected to an actuator that is configured to move the detector 313 within the body 203 and the optical sensor structure. In an example one may define that the actuator causes the detector to move perpendicularly in relation to an optical axis of the optical sensor structure. If the optical axis of the optical sensor structure is denoted

as z direction in three dimensional coordinates, the detector 313 may move in x and y directions. In an example one may define that the actuator causes the detector 313 to move laterally in relation to skin of the user wearing the apparatus. Moving the detector 313 changes the place / spot of the user's skin from where reflected light rays are detected by the sensor structure.

[0045] Furthermore the body 203 comprises a motion detector 215. In addition, the body comprises a processor or some other processing unit (not shown) that is configured to control functionalities of the body and the optical sensor structure. The processor may process measurement values or sensor signals received from the motion detector and the optical sensor structure, and control the optical sensor structure accordingly. The processor may for example determine desired monitoring area for the optical sensor structure and/or maintain monitoring at the desired monitoring area. The processor may cause the actuator to move the detector to change monitoring area of the optical sensor structure in order to determine the desired monitoring area. Additionally, the processor may cause the actuator to move the detector to compensate for movements of the apparatus in order to maintain the monitoring at the desired monitoring area.

[0046] In Fig 3B, the body 203 comprises an optical sensor structure comprising an optical emitter 310, emitter optics 212, detector 213 and detector optics 314. The optical sensor structure is configured to produce sensor signals corresponding to a property of the skin or underlying matter (capillaries and veins, for example). In the example of Fig. 3B the optical emitter 310 comprises or is operatively connected to an actuator that is configured to move the optical emitter 310 within the body 203 and the optical sensor structure. In an example one may define that the actuator causes the optical emitter to move perpendicularly in relation to an optical axis of the optical sensor structure. If the optical axis of the optical sensor structure is denoted as z direction in three dimensional coordinates, the optical emitter 310 may move in x and y directions. In an example one may define that the actuator causes the optical emitter 310 to move laterally in relation to skin of the user wearing the apparatus. Moving the optical emitter 310 changes the place / spot of the user's skin from where reflected light rays are detected by the sensor structure.

[0047] Furthermore the body 203 comprises a motion detector 215. In addition, the body comprises a processor or some other processing unit (not shown) that is configured to control functionalities of the body and the optical sensor structure. The processor may process measurement values or sensor signals received from the motion detector and the optical sensor structure, and control the optical sensor structure accordingly. The processor may for example determine desired monitoring area for the optical sensor structure and/or maintain monitoring at the desired monitoring area. The processor may cause the actuator to move the optical emitter 310 to change monitoring area of the optical sensor structure in order to de-

termine the desired monitoring area. Additionally, the processor may cause the actuator to move the optical emitter 310 to compensate for movements of the apparatus in order to maintain the monitoring at the desired monitoring area.

[0048] In Fig 3C, the body 203 comprises an optical sensor structure 355 comprising an optical emitter 210, emitter optics 212, detector 213 and detector optics 314. The optical sensor structure is configured to produce sensor signals corresponding to a property of the skin or underlying matter (capillaries and veins, for example). In the example of Fig. 3C the optical sensor structure 355 comprises or is operatively connected to an actuator that is configured to move the optical sensor structure 355 within the body 203. In an example one may define that the actuator causes the optical sensor structure 355 to move perpendicularly in relation to an optical axis of the optical sensor structure. If the optical axis of the optical sensor structure is denoted as z direction in three dimensional coordinates, the optical sensor structure 355 may move in x and y directions. In an example one may define that the actuator causes the optical sensor structure 355 to move laterally in relation to skin of the user wearing the apparatus.

[0049] Furthermore the body 203 comprises a motion detector 215. In addition, the body comprises a processor or some other processing unit (not shown) that is configured to control functionalities of the body and the optical sensor structure. The processor may process measurement values or sensor signals received from the motion detector and the optical sensor structure, and control the optical sensor structure accordingly. The processor may for example determine desired monitoring area for the optical sensor structure and/or maintain monitoring at the desired monitoring area. The processor may cause the actuator to move the optical sensor structure 355 to change monitoring area of the optical sensor structure in order to determine the desired monitoring area. Additionally, the processor may cause the actuator to move the optical sensor structure 355 to compensate for movements of the apparatus in order to maintain the monitoring at the desired monitoring area.

[0050] Figs. 2A-3B show examples where the movable part of the optical sensor structure is the detector or the detector optics or alternatively the optical emitter or emitter optics. Also some other part may be moved to cause changes in monitoring area of the optical sensor structure and/or to change the optical path of the optical sensor structure. The movement of the movable part may be a lateral movement or an internal movement inside the movable part.

[0051] It is noted that the apparatus of Figs. 2A-3C may be shaped like a watch and it may be configured to display time or other useful information to the user. The body 203 of the apparatus may be made of any of metals; plastics; carbon fiber materials; glass; wood; ceramics; and any combination or composition thereof. The body 203 of the apparatus can be formed roughly as a concave

block or unit or as a block or unit with a cut-out on one side thereof. The strap 202 may be made of suitable flexible or bendable material, such as plastic, fabric, and leather. In an example embodiment, the strap 202 and the body 203 are integrally formed of one piece of material. The material can comprise or consist of any of the following: plastics, metals, nano-fibers, carbon fiber, leather, and glass.

[0052] Figs. 2A-3C show a wrist strap as an example apparatus. Alternatively an apparatus according to example embodiments of the invention may be some other device that is wearable by a user. The apparatus may be a device that is configured to be integrated into a garment of a user. The device may be attached or integrated for example to a belt, a sock, a shoe, a sleeve or a collar of a shirt or pullover, and/or a waistband of trousers or skirt. The device may be detachable from the garment.

[0053] Fig. 4 illustrates operation principle of an example embodiment. The shown example is based on the apparatus of Fig. 2 where the detector optics 214 is movable.

[0054] In heart rate monitoring the optical sensor structure works as follows: the optical emitter 210 (e.g. a LED) illuminates certain area 401 of a wrist of a user. The apparatus (e.g. a processor therein) studies the volume of changes of blood vessels 402, 403. The detector 213 receives light rays 406 reflected from the wrist. If the apparatus moves in relation to the wrist, the reflected light rays come to the detector 213 from different area than earlier. This causes discontinuity and stops the measurement for a certain period. If the movement happens constantly, the apparatus is unable to perform the monitoring at all. This problem is removed by moving the detector optics and by thereby changing the optical path of the light rays. In the shown example, the apparatus moves in the direction of arrow 411. The movement is detected by the motion detector 215 and in order to compensate for the movement the detector optics 214 are caused to move in the direction of arrow 412 so that light rays from the same area, that was previously monitored, are folded to the detector. In this way light rays from the desired area (e.g. the most optimum area) are guided to the detector 213 regardless of the apparatus movement.

[0055] Fig. 5 shows a block diagram of the apparatus 500 of an example embodiment, for helping understanding of various processing and control related aspects. The apparatus 500 can be suited for use as the apparatus of Figs. 2 and 3.

[0056] The apparatus 500 comprises a radio unit 550, a processor 540 coupled to the radio unit 550, and a memory 560 coupled to the processor 540. The apparatus further comprises a motion detector 590, a physiological sensor 510, and a user interface (U/I) unit 520, such as a touch sensitive display, which are coupled to the processor 540.

[0057] The memory 560 comprises a work memory and a non-volatile memory such as a read-only memory, flash memory, optical or magnetic memory. In the mem-

ory 560, typically at least initially in the non-volatile memory, there is stored software 570 operable to be loaded into and executed by the processor 540. The software 570 may comprise one or more software modules and can be in the form of a computer program product that is software stored in a memory medium.

[0058] The radio unit 550 is configured to provide communications to other devices or communication networks over one or more links. The links may be wired and/or wireless links. The communication interface 550 may further or alternatively implement telecommunication links suited for establishing links with other users or for data transfer, e.g. using the Internet. Such telecommunication links may be links using any of: wireless local area network links, Bluetooth, ultra-wideband, cellular or satellite communication links.

[0059] The motion detector 590 is configured to detect movements of the apparatus 500 in relation to the body of the user. The motion detector may be for example an optical sensor or an accelerometer.

[0060] The physiological sensor 510 is an optical sensor that is configured to monitor certain physiological property of a user wearing the apparatus 500. The physiological sensor 510 comprises an actuator 530 that is operable to move one or more internal parts or components of the physiological sensor 510. The movement caused by the actuator 530 may alter optical path of light rays used in the physiological sensor 510. The actuator 530 may move the part of the physiological sensor 510 without moving the whole sensor element 510. Alternatively, the actuator may move the whole sensor element 510 without moving the apparatus 500. The internal parts of the physiological sensor are not shown in Fig 5 for the sake of clarity.

[0061] The processor 540 is, for instance, a central processing unit (CPU), a microprocessor, a digital signal processor (DSP), a graphics processing unit, an application specific integrated circuit (ASIC), a field programmable gate array, a microcontroller or a combination of such elements. In an example embodiment the processor is configured, in response to signals received from the motion detector 590 and/or the physiological sensor 510 to control the actuator 530 of the physiological sensor to move one or more internal parts of the physiological sensor 510 for example to alter optical path of light rays used in the physiological sensor 510. In an example embodiment the processor is configured to control the actuator 530 of the physiological sensor to move one or more internal parts of the physiological sensor 510 to change the monitored area of a body of a user of the apparatus 500 in order to determine a desired monitoring area. In an example embodiment the processor is configured to determine, based on movements detected by the motion detection sensor, movements required for internal parts of the physiological sensor 510 and/or changes required in the optical path of light rays used in the physiological sensor 510 to compensate for the movements of the apparatus 500.

[0062] A skilled person appreciates that in addition to the elements shown in Fig. 5, the apparatus 500 may comprise other elements, such as microphones, displays, and batteries.

5 **[0063]** It shall be understood that any coupling in this document refers to functional or operational coupling; there may be intervening components or circuitries in between coupled elements unless expressly otherwise described.

10 **[0064]** Fig. 6 shows a flow chart of a process of an example embodiment. The process comprises: 610 moving an internal part of a sensor structure to change measurement area of the sensor structure (e.g. an optical component, detector component, light source component or a suitable combination thereof may be moved); 620 determining desired measurement area (e.g. an area that fulfills certain predefined criteria, an area where one detects most optimal blood vessels for heart rate monitoring, or an area that exhibits strongest signal); 630 starting measurement at the desired measurement area (comprising for example locking the measurement to the desired area); and 640 compensating for movements of the apparatus by moving the at least one internal part of the sensor structure to maintain the measurement at the desired measurement area. In an example embodiment the whole sensor structure may be moved inside the apparatus to change the measurement area of the sensor structure or to compensate for the movements of the apparatus.

20 25 30 **[0065]** Fig. 7 shows a flow chart of a process of an example embodiment. The process comprises: 710 changing optical path of light rays to change measurement area of a sensor structure; 620 determining desired measurement area (e.g. an area that fulfills certain predefined criteria, an area where one detects most optimal blood vessels for heart rate monitoring, or an area that exhibits strongest signal); 630 starting measurement at the desired measurement area (comprising for example locking the measurement to the desired area); and 740 compensating for movements of the apparatus by changing optical path of light rays to maintain the measurement at the desired measurement area.

35 40 45 50 55 **[0066]** Without in any way limiting the scope, interpretation, or application of the claims appearing below, a technical effect of one or more of the example embodiments disclosed herein is that optical monitoring of physiological properties, such as heart rate, is improved. For example reliability of the monitoring is enhanced. Another technical effect of one or more of the example embodiments disclosed herein is that signal quality is improved as a monitoring area fulfilling predefined criteria or a monitoring area providing the best results is searched for before starting the monitoring. Another technical effect of one or more of the example embodiments disclosed herein is that the apparatus may be allowed to move without disturbing or stopping the monitoring process. Another technical effect of one or more of the example embodiments disclosed herein is that there is no need for elec-

trical stabilization or compensation or other processing of results performed on the detected signals as the movements of the apparatus are compensated for before the light rays hit the detector.

[0067] If desired, the different functions discussed herein may be performed in a different order and/or concurrently with each other. Furthermore, if desired, one or more of the before-described functions may be optional or may be combined.

[0068] Although various aspects of the invention are set out in the independent claims, other aspects of the invention comprise other combinations of features from the described embodiments and/or the dependent claims with the features of the independent claims, and not solely the combinations explicitly set out in the claims.

[0069] It is also noted herein that while the foregoing describes example embodiments of the invention, these descriptions should not be viewed in a limiting sense. Rather, there are several variations and modifications which may be made without departing from the scope of the present invention as defined in the appended claims.

Claims

1. A user wearable apparatus; comprising:

an optical sensor structure (510) configured to optically monitor an area of a body (201) of a user wearing the apparatus to monitor a physiological property of the user, and a processor (540) configured

to cause movement of at least one part of the optical sensor structure to change the monitored area of the body (201) of the user and to determine a desired monitoring area, wherein the movement of the at least one part of the optical sensor structure causes changes in optical path of light rays used in the optical sensor structure, wherein the desired monitoring area is an area where a measured signal is strongest or where the measured signal exceeds a threshold value, and

to maintain the monitoring of the physiological property of the user at the determined desired monitoring area.

2. The user wearable apparatus of claim 1, wherein the optical sensor structure comprises a light source (210) configured to illuminate an area of the body of the user wearing the apparatus, and a detector (213) configured to detect light rays reflected from the body of the user to monitor the physiological property of the user.

3. The user wearable apparatus of any preceding

claim, wherein the movement of the at least one part of the optical sensor structure comprises movement of the whole optical sensor structure.

4. The user wearable apparatus of any preceding claim, wherein the optical sensor structure comprises an actuator (530) configured to move the at least one part of the optical sensor structure, and wherein the processor is configured to control the actuator to move the at least one part of the optical sensor structure.

5. The user wearable apparatus of any preceding claim, wherein the at least one part of the optical sensor structure is moved laterally in relation to optical axis of the optical sensor structure.

6. The user wearable apparatus of any preceding claim, wherein the movement of the at least one part of the optical sensor structure is movement of an internal structure of the at least one part of the optical sensor structure.

7. The user wearable apparatus of any one of claims 4-6, wherein the optical sensor structure comprises an optical emitter (210) and emitter optics (212); and an optical detector (213) and detector optics (214); and wherein the actuator is configured to move at least one of: the optical emitter, the emitter optics, the optical detector, and the detector optics.

8. The user wearable apparatus of any one of claims 4-7, wherein the actuator is a stabilizer comprised in or operatively connected to a movable part of the optical sensor structure.

9. The user wearable apparatus of any preceding claim, wherein the processor is configured to cause movement of the at least one part of the optical sensor structure to compensate for movements of the user wearable apparatus and to maintain the monitoring of the physiological property of the user at the determined desired monitoring area.

10. The user wearable apparatus of claim 9, further comprising a motion detection sensor (215, 590) configured to detect movements of the user wearable apparatus in relation to the body of the user, wherein the processor is configured to determine, based on movements detected by the motion detection sensor, movement required for the at least one part of the optical sensor structure to compensate for the movements of the user wearable apparatus.

11. The user wearable apparatus of any preceding claim, wherein the desired monitoring area is an area

that fulfills certain predefined criteria.

12. The user wearable apparatus of any preceding claim, wherein the physiological property is heart rate.
13. The user wearable apparatus of any preceding claim, wherein the apparatus is one of: a wrist strap, an ankle strap, a device configured to be integrated into a garment of a user.

14. A method comprising:

using an optical sensor structure (510) to optically monitor an area of a body (201) of a user wearing a user wearable apparatus to monitor a physiological property of the user, moving (610) at least one part of the optical sensor structure to change the monitored area of the body of the user and to determine a desired monitoring area, wherein the movement of the at least one part of the optical sensor structure causes changes (710) in optical path of light rays used in the optical sensor structure, wherein the desired monitoring area is an area where a measured signal is strongest or where the measured signal exceeds a threshold value, and maintaining (640, 740) the monitoring of the physiological property of the user at the determined desired monitoring area.

Patentansprüche

1. Von einem Anwender tragbare Vorrichtung, die Folgendes umfasst:

eine optische Sensorstruktur (510), die konfiguriert ist, einen Bereich eines Körpers (201) eines Anwenders, der die Vorrichtung trägt, optisch zu überwachen, um eine physiologische Eigenschaft des Anwenders zu überwachen, und einen Prozessor (540), der konfiguriert ist, eine Bewegung mindestens eines Teils der optischen Sensorstruktur zu bewirken, um den überwachten Bereich des Körpers (201) des Anwenders zu ändern und einen gewünschten Überwachungsbereich zu bestimmen, wobei die Bewegung des mindestens einen Teils der optischen Sensorstruktur Änderungen im optischen Pfad von Lichtstrahlen, die in der optischen Sensorstruktur verwendet werden, bewirkt, wobei der gewünschte Überwachungsbereich ein Bereich ist, in dem ein gemessenes Signal am stärksten ist oder in dem das gemessene Signal einen Schwellenwert überschreitet, und die Überwachung der physiologischen Eigen-

schaft des Anwenders im bestimmten gewünschten Überwachungsbereich aufrechtzuhalten.

2. Von einem Anwender tragbare Vorrichtung nach Anspruch 1, wobei die optische Sensorstruktur Folgendes umfasst:

eine Lichtquelle (210), die konfiguriert ist, einen Bereich des Körpers des Anwenders, der die Vorrichtung trägt, zu beleuchten, und einen Detektor (213), der konfiguriert ist, Lichtstrahlen, die vom Körper des Anwenders reflektiert werden, zu detektieren, um die physiologische Eigenschaft des Anwenders zu überwachen.

3. Von einem Anwender tragbare Vorrichtung nach einem vorhergehenden Anspruch, wobei die Bewegung des mindestens einen Teils der optischen Sensorstruktur eine Bewegung der gesamten optischen Sensorstruktur umfasst.

4. Von einem Anwender tragbare Vorrichtung nach einem vorhergehenden Anspruch, wobei die optische Sensorstruktur einen Aktor (530) umfasst, der konfiguriert ist, den mindestens einen Teil der optischen Sensorstruktur zu bewegen, und der Prozessor konfiguriert ist, den Aktor zu steuern, den mindestens einen Teil der optischen Sensorstruktur zu bewegen.

5. Von einem Anwender tragbare Vorrichtung nach einem vorhergehenden Anspruch, wobei sich der mindestens eine Teil der optischen Sensorstruktur in Bezug auf die optische Achse der optischen Sensorstruktur seitlich bewegt.

6. Von einem Anwender tragbare Vorrichtung nach einem vorhergehenden Anspruch, wobei die Bewegung des mindestens einen Teils der optischen Sensorstruktur eine Bewegung einer internen Struktur des mindestens einen Teils der optischen Sensorstruktur ist.

7. Von einem Anwender tragbare Vorrichtung nach einem der Ansprüche 4-6, wobei die optische Sensorstruktur einen optischen Sender (210) und eine Senderoptik (212); und einen optischen Detektor (213) und eine Detektoroptik (214) umfasst; und wobei der Aktor konfiguriert ist, Folgendes zu bewegen: den optischen Sender, die Senderoptik, den optischen Detektor und/oder die Detektoroptik.

8. Von einem Anwender tragbare Vorrichtung nach einem der Ansprüche 4-7, wobei der Aktor eine Stabilisierungseinrichtung ist, die in einem beweglichen Teil der optischen Sensorstruktur enthalten ist oder mit ihr funktionstechnisch verbunden ist.

9. Von einem Anwender tragbare Vorrichtung nach einem vorhergehenden Anspruch, wobei der Prozessor konfiguriert ist, eine Bewegung des mindestens einen Teils der optischen Sensorstruktur zu bewirken, um Bewegungen der von einem Anwender tragbaren Vorrichtung zu kompensieren und das Überwachen der physiologischen Eigenschaft des Anwenders im bestimmten gewünschten Überwachungsbereich aufrechtzuerhalten.

10. Von einem Anwender tragbare Vorrichtung nach Anspruch 9, die ferner Folgendes umfasst:

einen Bewegungserfassungssensor (215, 590), der konfiguriert ist, Bewegungen der von einem Anwender tragbaren Vorrichtung in Bezug zum Körper des Anwenders zu detektieren, wobei der Prozessor konfiguriert ist, auf der Grundlage von Bewegungen, die durch den Bewegungserfassungssensor erfasst wurden, eine Bewegung zu bestimmen, die erforderlich ist, damit der mindestens eine Teil der optischen Sensorstruktur die Bewegungen der von einem Anwender tragbaren Vorrichtung kompensieren kann.

11. Von einem Anwender tragbare Vorrichtung nach einem vorhergehenden Anspruch, wobei der gewünschte Überwachungsbereich ein Bereich ist, der bestimmte vordefinierte Kriterien erfüllt.

12. Von einem Anwender tragbare Vorrichtung nach einem vorhergehenden Anspruch, wobei die physiologische Eigenschaft eine Herzfrequenz ist.

13. Von einem Anwender tragbare Vorrichtung nach einem vorhergehenden Anspruch, wobei die Vorrichtung Folgendes ist: ein Handgelenkband, ein Fußgelenkband oder eine Einrichtung, die konfiguriert ist, in ein Kleidungsstück eines Anwenders integriert zu sein.

14. Verfahren, das Folgendes umfasst:

Verwenden einer optischen Sensorstruktur (510), um einen Bereich eines Körpers (201) eines Anwenders, der die Vorrichtung trägt, optisch zu überwachen, um eine physiologische Eigenschaft des Anwenders zu überwachen, Bewegungen (610) mindestens eines Teils der optischen Sensorstruktur, um den überwachten Bereich des Körpers des Anwenders zu ändern und einen gewünschten Überwachungsbereich zu bestimmen, wobei die Bewegung des mindestens einen Teils der optischen Sensorstruktur Änderungen (710) im optischen Pfad von Lichtstrahlen, die in der optischen Sensorstruktur verwendet werden, bewirkt, wobei der gewünschte Überwachungsbereich ein Bereich

ist, in dem ein gemessenes Signal am stärksten ist oder in dem das gemessene Signal einen Schwellenwert überschreitet, und Aufrechterhalten (640, 740) der Überwachung der physiologischen Eigenschaft des Anwenders im bestimmten gewünschten Überwachungsbereich.

10 Revendications

1. Appareil portable par un utilisateur ; comprenant :

une structure de capteur optique (510) configurée pour surveiller optiquement une zone d'un corps (201) d'un utilisateur portant l'appareil pour surveiller une propriété physiologique de l'utilisateur, et un processeur (540) configuré

pour provoquer un mouvement d'au moins une partie de la structure de capteur optique pour changer la zone surveillée du corps (201) de l'utilisateur et pour déterminer une zone de surveillance souhaitée, dans lequel le mouvement de ladite au moins une partie de la structure de capteur optique provoque des changements du chemin optique des rayons lumineux utilisés dans la structure de capteur optique, dans lequel la zone de surveillance souhaitée est une zone dans laquelle un signal mesuré est le plus fort ou dans laquelle le signal mesuré dépasse une valeur seuil, et pour maintenir la surveillance de la propriété physiologique de l'utilisateur dans la zone de surveillance souhaitée déterminée.

2. Appareil portable par un utilisateur selon la revendication 1, dans lequel la structure de capteur optique comprend

une source de lumière (210) configurée pour éclairer une zone du corps de l'utilisateur portant l'appareil, et

un détecteur (213) configuré pour détecter des rayons lumineux réfléchis par le corps de l'utilisateur pour surveiller la propriété physiologique de l'utilisateur.

3. Appareil portable par un utilisateur selon l'une quelconque des revendications précédentes, dans lequel le mouvement de ladite au moins une partie de la structure de capteur optique comprend un mouvement de la structure de capteur optique tout entière.

4. Appareil portable par un utilisateur selon l'une quelconque des revendications précédentes, dans le-

- quel la structure de capteur optique comprend un actionneur (530) configuré pour déplacer ladite au moins une partie de la structure de capteur optique, et dans lequel le processeur est configuré pour commander l'actionneur pour déplacer ladite au moins une partie de la structure de capteur optique.
5. Appareil portable par un utilisateur selon l'une quelconque des revendications précédentes, dans lequel ladite au moins une partie de la structure de capteur optique est déplacée latéralement par rapport à l'axe optique de la structure de capteur optique.
6. Appareil portable par un utilisateur selon l'une quelconque des revendications précédentes, dans lequel le mouvement de ladite au moins une partie de la structure de capteur optique est un mouvement d'une structure interne de ladite au moins une partie de la structure de capteur optique.
7. Appareil portable par un utilisateur selon l'une quelconque des revendications 4 à 6, dans lequel la structure de capteur optique comprend un émetteur optique (210) et une optique d'émetteur (212) ; et un détecteur optique (213) et une optique de détecteur (214) ; et dans lequel l'actionneur est configuré pour déplacer au moins un élément parmi : l'émetteur optique, l'optique d'émetteur, le détecteur optique et l'optique de détecteur.
8. Appareil portable par un utilisateur selon l'une quelconque des revendications 4 à 7, dans lequel l'actionneur est un stabilisateur compris dans ou connecté de manière opérationnelle à une partie mobile de la structure de capteur optique.
9. Appareil portable par un utilisateur selon l'une quelconque des revendications précédentes, dans lequel le processeur est configuré pour provoquer un mouvement de ladite au moins une partie de la structure de capteur optique pour compenser des mouvements de l'appareil portable par un utilisateur et pour maintenir la surveillance de la propriété physiologique de l'utilisateur dans la zone de surveillance souhaitée déterminée.
10. Appareil portable par un utilisateur selon la revendication 9, comprenant en outre un capteur de détection de mouvement (215, 590) configuré pour détecter des mouvements de l'appareil portable par un utilisateur par rapport au corps de l'utilisateur, dans lequel le processeur est configuré pour déterminer, sur la base de mouvements détectés par le capteur de détection de mouvement, un mouvement nécessaire pour ladite au moins une partie de la structure de capteur optique pour compenser les mouvements
- de l'appareil portable par un utilisateur.
11. Appareil portable par un utilisateur selon l'une quelconque des revendications précédentes, dans lequel la zone de surveillance souhaitée est une zone qui répond à certains critères prédéfinis.
12. Appareil portable par un utilisateur selon l'une quelconque des revendications précédentes, dans lequel la propriété physiologique est le rythme cardiaque.
13. Appareil portable par un utilisateur selon l'une quelconque des revendications précédentes, dans lequel l'appareil est un élément parmi : un bracelet au poignet, un bracelet à la cheville, un dispositif configuré pour être intégré dans un vêtement d'un utilisateur.
14. Procédé, comprenant :
- l'utilisation une structure de capteur optique (510) pour surveiller de manière optique une zone d'un corps (201) d'un utilisateur portant un appareil portable par un utilisateur pour surveiller une propriété physiologique de l'utilisateur, le déplacement (610) d'au moins une partie de la structure de capteur optique pour changer la zone surveillée du corps de l'utilisateur et pour déterminer une zone de surveillance souhaitée, dans lequel le mouvement de ladite au moins une partie de la structure de capteur optique provoque des changements (710) du chemin optique des rayons lumineux utilisés dans la structure de capteur optique, la zone de surveillance souhaitée étant une zone dans laquelle un signal mesuré est le plus fort ou dans laquelle le signal mesuré dépasse une valeur seuil, et le maintien (640, 740) de la surveillance de la propriété physiologique de l'utilisateur dans la zone de surveillance souhaitée déterminée.

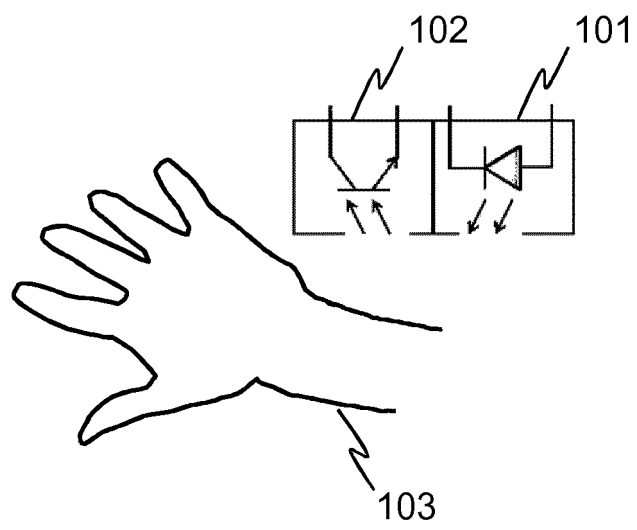

Fig. 1

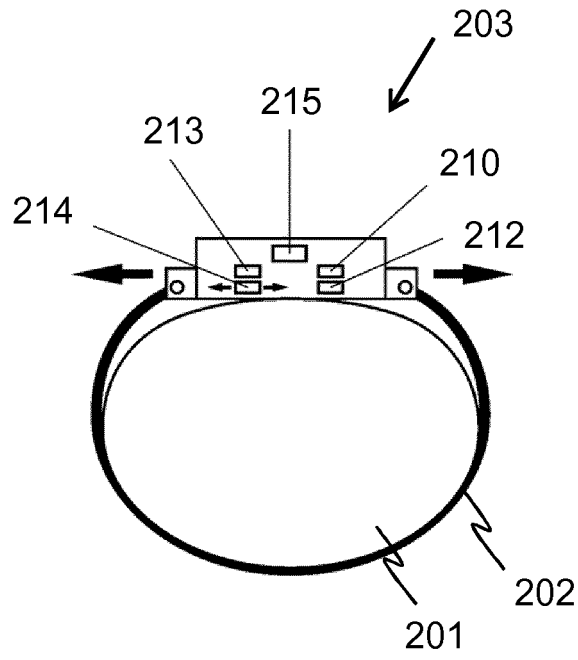

Fig. 2A

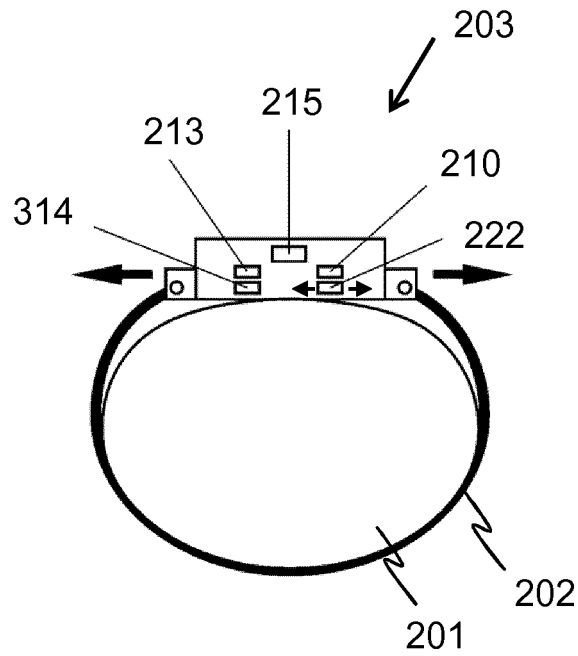

Fig. 2B

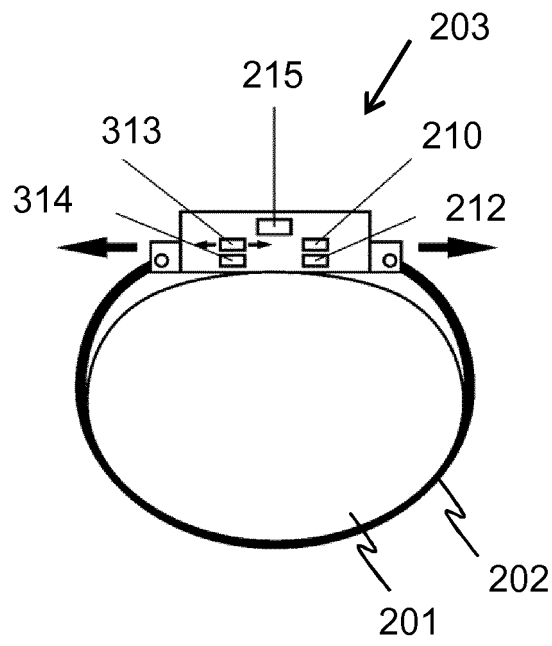

Fig. 3A

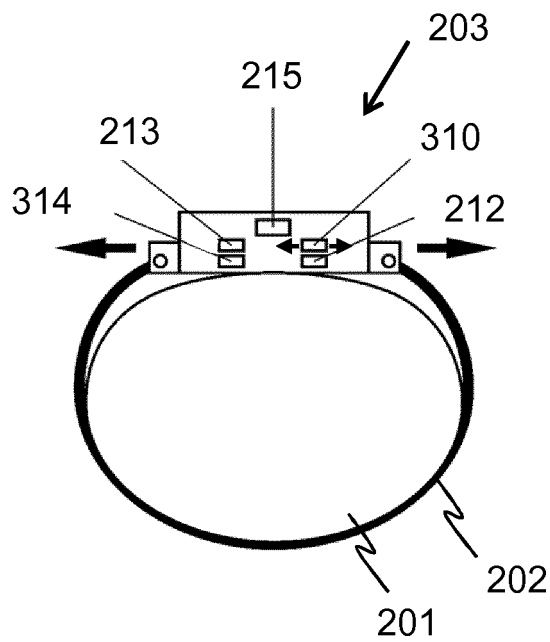

Fig. 3B

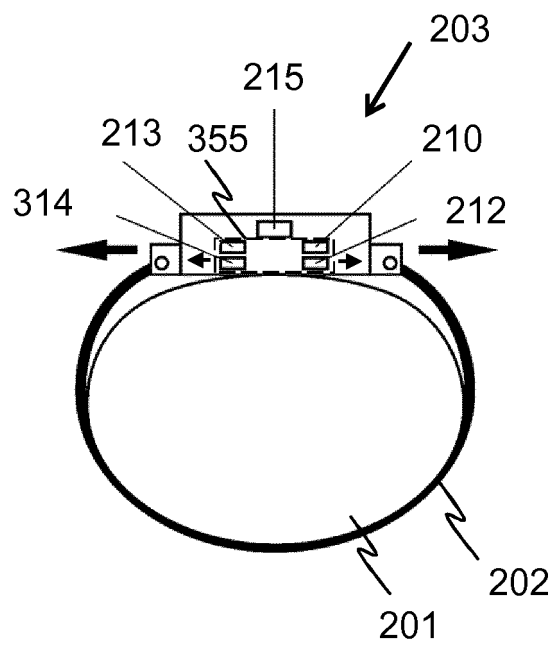

Fig. 3C

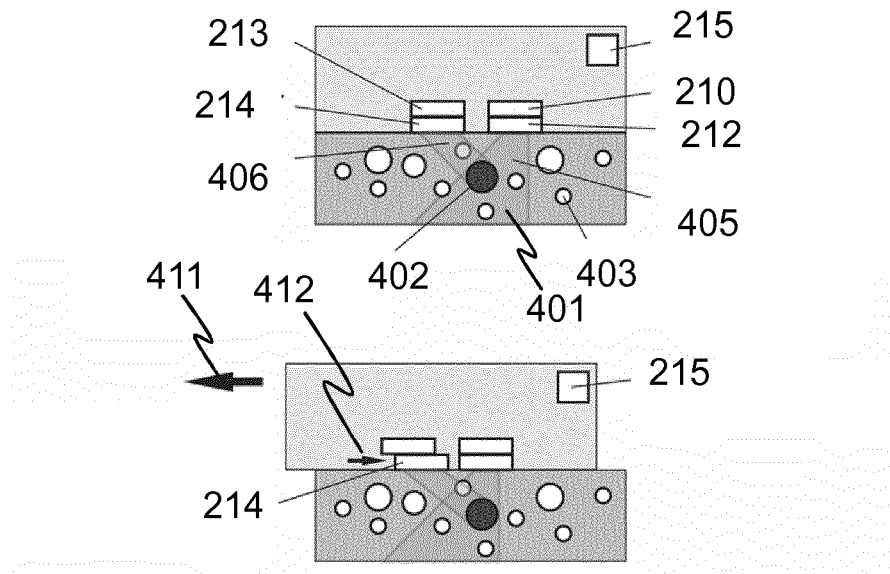

Fig. 4

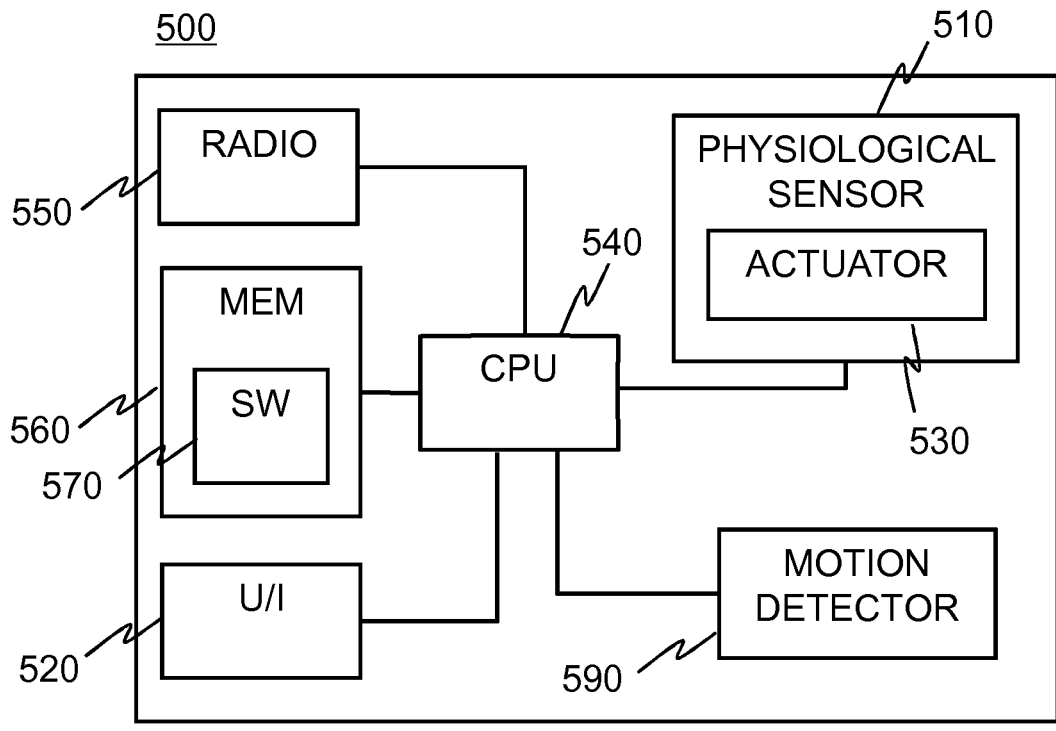
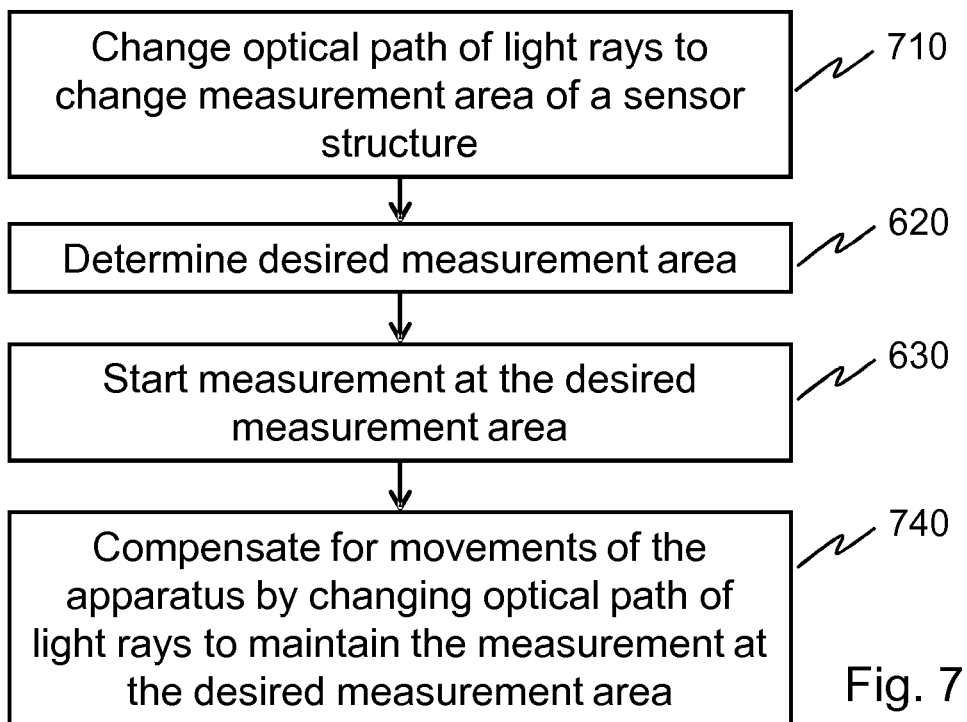
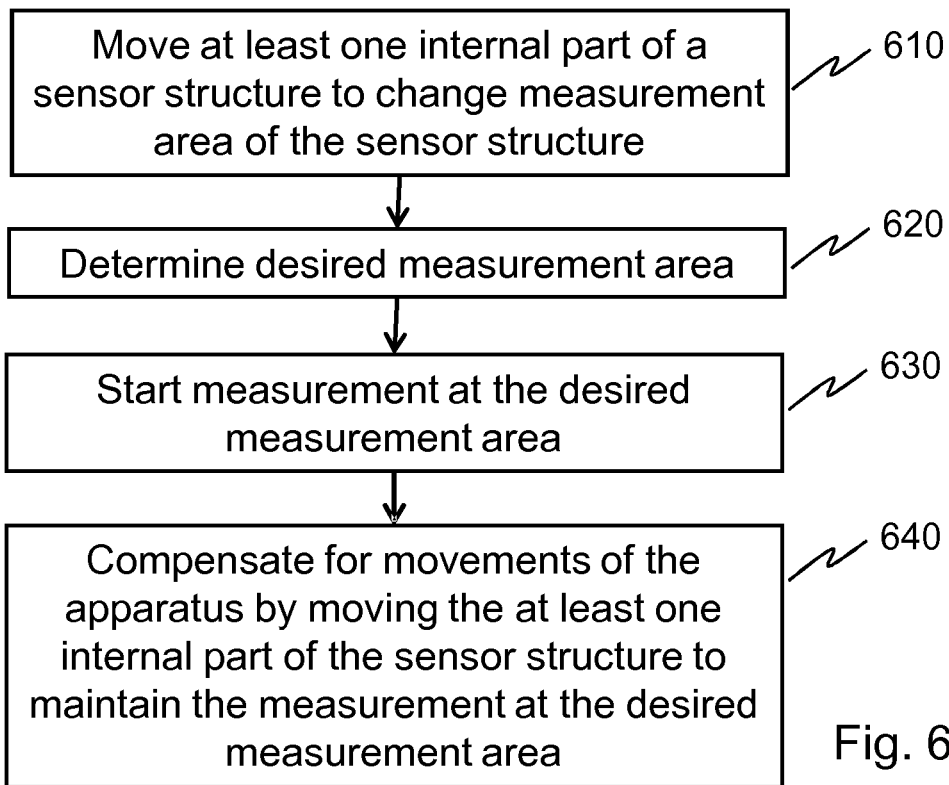

Fig. 5



REFERENCES CITED IN THE DESCRIPTION

This list of references cited by the applicant is for the reader's convenience only. It does not form part of the European patent document. Even though great care has been taken in compiling the references, errors or omissions cannot be excluded and the EPO disclaims all liability in this regard.

Patent documents cited in the description

- US 2014275854 A [0005]

专利名称(译)	带有光学传感器的用户可穿戴设备		
公开(公告)号	EP3064128B1	公开(公告)日	2019-10-23
申请号	EP2015157297	申请日	2015-03-03
[标]申请(专利权)人(译)	诺基亚技术有限公司		
申请(专利权)人(译)	NOKIA TECHNOLOGIES OY		
当前申请(专利权)人(译)	NOKIA TECHNOLOGIES OY		
[标]发明人	ROUVINEN JARKKO KOSONEN MATTI		
发明人	ROUVINEN, JARKKO KOSONEN, MATTI		
IPC分类号	A61B5/024 A61B5/1455 A61B5/00		
其他公开文献	EP3064128A1		
外部链接	Espacenet		

摘要(译)

用户可佩戴设备包括光学传感器结构，该光学传感器结构被配置为光学地监视佩戴该设备的用户的身体区域以监视用户的生理特性。引起光学传感器结构的至少一部分的移动以改变用户的身体的被监视区域并确定期望的监视区域，然后，将用户的生理特性的监视保持在确定的期望的位置。监控区。

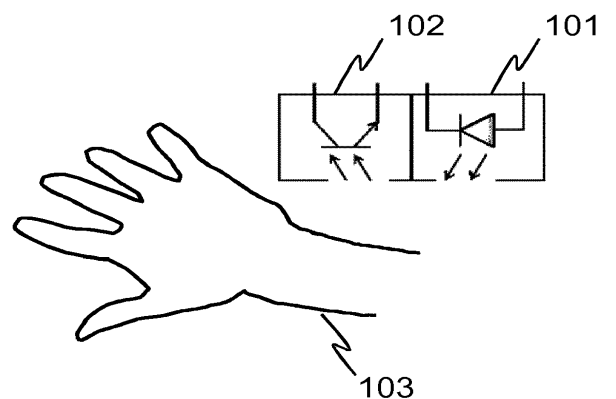

Fig. 1