

(19)



(11)

EP 2 142 087 B1

(12)

EUROPEAN PATENT SPECIFICATION

(45) Date of publication and mention of the grant of the patent:

29.06.2016 Bulletin 2016/26

(21) Application number: **08742578.1**

(22) Date of filing: **03.04.2008**

(51) Int Cl.:

A61B 5/04 (2006.01)	A61B 5/0488 (2006.01)
A61B 5/0492 (2006.01)	A61B 17/16 (2006.01)
A61B 17/17 (2006.01)	A61B 5/00 (2006.01)
A61N 1/05 (2006.01)	A61N 1/08 (2006.01)
A61B 5/05 (2006.01)	A61N 1/36 (2006.01)
A61B 17/00 (2006.01)	

(86) International application number:

PCT/US2008/004427

(87) International publication number:

WO 2008/124079 (16.10.2008 Gazette 2008/42)

(54) **NEUROPHYSIOLOGIC MONITORING SYSTEM**

NEUROPHYSIOLOGISCHES ÜBERWACHUNGSSYSTEM

SYSTÈME DE SURVEILLANCE NEUROPHYSIOLOGIQUE

(84) Designated Contracting States:

AT BE BG CH CY CZ DE DK EE ES FI FR GB GR HR HU IE IS IT LI LT LU LV MC MT NL NO PL PT RO SE SI SK TR

(30) Priority: **03.04.2007 US 921718 P**

24.10.2007 US 354 P

(43) Date of publication of application:

13.01.2010 Bulletin 2010/02

(73) Proprietor: **Nuvasive Inc.**

San Diego, CA 92121 (US)

(72) Inventors:

- **GHARIB, James**
San Diego, CA 92130 (US)
- **FARQUHAR, Allen**
deceased (US)
- **LAYMAN, Doug**
San Diego, CA 92129 (US)

- **SCHOLL, Thomas**
San Diego, CA 92129 (US)
- **POTHIER, Albert**
San Diego, CA 92106 (US)
- **MARTINELLI, Scot**
Mountaintop, PA 18707 (US)
- **IVANKO, Dave**
San Diego, CA 92103 (US)
- **FERNANDES, Antonio**
San Jose, CA 95125 (US)

(74) Representative: **Boult Wade Tennant**

Verulam Gardens
70 Gray's Inn Road
London WC1X 8BT (GB)

(56) References cited:

US-A- 5 938 688	US-A- 5 947 964
US-A1- 2002 123 780	US-A1- 2005 004 623
US-A1- 2005 033 380	US-A1- 2006 052 828

EP 2 142 087 B1

Note: Within nine months of the publication of the mention of the grant of the European patent in the European Patent Bulletin, any person may give notice to the European Patent Office of opposition to that patent, in accordance with the Implementing Regulations. Notice of opposition shall not be deemed to have been filed until the opposition fee has been paid. (Art. 99(1) European Patent Convention).

Description**BACKGROUND OF THE INVENTION**5 **I. Field of the Invention**

[0001] The present invention relates to a system generally aimed at surgery. More particularly, the present invention is directed at a system for performing surgical procedures and assessments involving the use of neurophysiology.

10 **II. Description of Related Art**

[0002] Neurophysiology monitoring has become an increasingly important adjunct to surgical procedures where neural tissue may be at risk. Spinal surgery, in particular, involves working close to delicate tissue in and surrounding the spine, which can be damaged in any number of different ways. For example, an exiting nerve root may be compromised if surgical instruments have to pass near or close to the nerve while accessing the surgical target site in the spine. A spinal nerve and/or exiting nerve root may also be compromised if a pedicle screw, used often to secure fixation of multiple vertebra relative to each other, breaches the cortical layer of the pedicle. Surgeries targeting the spine may also require the retraction of nerve and/or vascular tissue out of the operative corridor. While doing so is necessary, there is a possibility of damaging nerve tissue through over retraction and/or a decreased supply of blood reaching the tissue due to the impingement of the retractor against the vascular tissue. Various neurophysiological techniques have been attempted and developed to monitor delicate nerve tissue during surgery in attempts to reduce the risk inherent in spine surgery (and surgery in general). Because of the complex structure of the spine and nervous system no single monitoring technique has been developed that may adequately assess the risk to nervous tissue in all situations and complex techniques are often utilised in conjunction one or more other complex monitoring techniques. EMG monitoring, for example, may be used to detect the presence of nerve roots near a surgical instrument or a breach formed in a pedicle wall. EMG monitoring is not, however, very effective when cord monitoring is required.

[0003] When cord monitoring is required one of motor evoked potential (MEP) and somatosensory evoked potential (SSEP) monitoring is often chosen. While both MEP and SSEP monitoring can be quite effective, MEP monitors the ventral column of the spinal cord and SSEP monitors the dorsal column. Danger to nerve tissue that might then be detected using one of these methods may be missed by the other, and vice versa. Thus it may be most effective to use both MEP and SSEP monitoring during the same procedure, while still potentially needing EMG monitoring as well.

[0004] EMG, MEP and SSEP involve complex analysis and specially trained neurophysiologists are generally called upon to perform the monitoring. Even though performed by specialists, interpreting the complex waveforms in this fashion is nonetheless disadvantageously prone to human error and can be disadvantageously time consuming, adding to the duration of the operation and translating into increased healthcare costs. Even more costly is the fact that the neurophysiologist is required in addition to the actual surgeon performing the spinal operation. Putting the difficulties associated with human interpretation of EMG, MEP and SSEP monitoring aside, combining such testing in the OR generally requires multiple products accommodate the differing requirements of each. This is disadvantageous when space is often as such a premium in the operating rooms of today. The present invention is directed at eliminating, or at least reducing the effects of, the above-described problems with the prior art.

[0005] US 2005/0004623 describes systems and related methods for performing percutaneous pedicle integrity assessments involving the use of neurophysiology according to the first part of claim 1. US 5,947,964 describes methods and apparatus for therapeutic cauterisation of predetermined volumes of biological tissue.

45 **SUMMARY OF THE INVENTION**

[0006] The present invention includes a system for avoiding harm to neural tissue during surgery as set out in claim 1. The system includes an instrument capable of advancement to a surgical target site and a processing system. The instrument is

50 configured to deliver a stimulation signal either while advancing to the target site and after reaching said target site. The processing system is programmed with a set of at least three threshold ranges and configured to direct a first stimulation signal to said instrument at a first magnitude. The first magnitude corresponds to a boundary between the pair of ranges. The processing system further directs a second stimulation signal at a second magnitude corresponding to a boundary between a different pair of the ranges. The processing unit is still further programmed to and measure the response of nerves depolarized by said stimulation signals to indicate at least one of nerve proximity and pedicle integrity.

[0007] Also described below is a system which includes a control unit, a patient module, and a plurality of surgical accessories adapted to couple to the patient module. The control unit includes a power supply and is programmed to receive user commands, activate stimulation in a plurality of predetermined modes, process signal data according to

defined algorithms, display received parameters and processed data, and monitor system status. The patient module is in communication with the control unit. The patient module is within the sterile field. The patient module includes signal conditioning circuitry, stimulator drive circuitry, and signal conditioning circuitry required to perform said stimulation in said predetermined modes. The patient module includes a processor programmed to perform a plurality of predetermined functions including at least two of static pedicle integrity testing, dynamic pedicle integrity testing, nerve proximity detection, neuromuscular pathway assessment, manual motor evoked potential monitoring, automatic motor evoked potential monitoring, somatosensory evoked potential monitoring, non-evoked monitoring, and surgical navigation.

[0008] Also described below is an instrument and a processing system. The instrument is in communication with the processing unit. The instrument is capable of advancement to a surgical target site and is configured to deliver a stimulation signal at least one of while advancing to said target site and after reaching said target site. The processing unit is programmed to perform a plurality of predetermined functions using said instrument including at least two of static pedicle integrity testing, dynamic pedicle integrity testing, nerve proximity detection, neuromuscular pathway assessment, manual motor evoked potential monitoring, automatic motor evoked potential monitoring, somatosensory evoked potential monitoring, non-evoked monitoring, and surgical navigation. The processing system has a pre-established profile for at least one of said predetermined functions so as to facilitate the initiation of said at least one predetermined function.

BRIEF DESCRIPTION OF THE DRAWINGS

[0009] Many advantages of the present invention will be apparent to those skilled in the art with a reading of this specification in conjunction with the attached drawings, wherein like reference numerals are applied to like elements and wherein:

Figure 1 is a block diagram of an exemplary surgical system capable of conducting multiple nerve and spinal cord monitoring functions including but not necessarily limited to MEP, SSEP, neuromuscular pathway, bone integrity, nerve detection, and nerve pathology (evoked or free-run EMG) assessments;

Fig. 2 is a perspective view showing examples of several components of the neurophysiology system of Fig. 1;

Fig. 3 is a graph illustrating a plot of a single pulse stimulation current signal capable of producing a neuromuscular response (EMG) of the type shown in FIG. 5;

Fig. 4 is a graph illustrating a plot of a stimulation current signal comprising a train of pulses capable of producing a neuromuscular response (EMG) of the type shown in FIG. 5;

Figure 5 is a graph illustrating a plot of the neuromuscular response (EMG) of a given myotome over time based on a stimulation signal (such as shown in either Fig. 3, or Fig.4);

Fig. 6 is a perspective view of an example of a control unit forming part of the neurophysiology system of Fig. 1;

Figs. 7-9 are perspective, top, and side views, respectively, of an example of a patient module forming part of the neurophysiology system of Fig. 1;

Fig. 10 is a top view of an electrode harness 80 forming part of the neurophysiology system of Fig. 1;

Figs. 11A-11C are side views of various examples of harness ports forming part of the neurophysiology system of Fig. 1;

Fig. 12 is a plan view of an example of a label affixed to an electrode connector forming part of the neurophysiology system of Fig. 1;

Figs 13A-13B are top views of examples of electrode caps forming part of the neurophysiology system of Fig. 1;

Fig. 14A is a block diagram setting forth the features of an electrode test as implemented on an electrode test screen forming part of the neurophysiology system of Fig. 1;

Fig. 14B is a screenshot capturing the features of Fig. 14A;

Figs. 15-17 are perspective, top, and side views, respectively, of an example of a stimulation probe accessory

forming part of the neurophysiology system of Fig. 1;

Fig. 18 is side view of an example of a stimulation clip accessory forming part of the neurophysiology system of Fig. 1;

5 Figs. 19-20 are perspective views of individual components of the stimulation clip of Fig. 18;

Figs. 21-22 are perspective views of an example of a secondary display forming part of the neurophysiology system of Fig. 1;

10 Fig. 23A-23B are a block diagram and screenshot, respectively, of an example of a startup screen forming part of the neurophysiology system of Fig. 1;

Fig. 24A-24B are a block diagram and screenshot, respectively, of an example of a monitoring screen forming part of the neurophysiology system of Fig. 1;

15 Fig. 25A-25B are a block diagram and screenshot, respectively, of a second example of a monitoring screen forming part of the neurophysiology system of Fig. 1;

Fig. 26A-26B are a block diagram and screenshot, respectively, of a third example of a monitoring screen forming part of the neurophysiology system of Fig. 1;

Fig. 27A-27B are a block diagram and screenshot, respectively, of a fourth example of a monitoring screen forming part of the neurophysiology system of Fig. 1;

25 Fig. 28A-28B are a block diagram and screenshot, respectively, of a fifth example of a monitoring screen forming part of the neurophysiology system of Fig. 1;

Fig. 29A-29B are a block diagram and screenshot, respectively, of a sixth example of a monitoring screen forming part of the neurophysiology system of Fig. 1;

30 Fig. 30 is a block diagram of a seventh example of a monitoring screen forming part of the neurophysiology system of Fig. 1;

Fig. 31 is a screen shot of an eighth example of a monitoring screen forming part of the neurophysiology system of Fig. 1;

Figs. 32A-32D are graphs illustrating the fundamental steps of a rapid current threshold-hunting algorithm;

Fig. 33 is block diagram illustrating the steps of an initiation sequence for determining a relevant safety level prior to determining a precise threshold value according to an embodiment of the invention.

Fig. 34 is a flowchart illustrating the method by which a multi-channel hunting algorithm determines whether to perform or omit a stimulation;

45 Fig. 35 are graphs illustrating use of the threshold hunting algorithm of Fig. 32 and further omitting stimulations when the likely result is already clear from previous data;

Fig. 36A is a flowchart illustrating the sequence employed by the algorithm to determine and monitor I_{thresh} ;

50 Fig. 36B is a graph illustrating the confirmation step employed by the algorithm to determine whether I_{thresh} has changed from a previous determination; and

Fig. 37 is a block diagram of a profile setting screenshot forming part of the neurophysiology monitoring system of Fig. 1.

55

DETAILED DESCRIPTION OF THE PREFERRED EMBODIMENT

[0010] Illustrative embodiments of the invention are described below. In the interest of clarity, not all features of an

actual implementation are described in this specification. It will of course be appreciated that in the development of any such actual embodiment, numerous implementation-specific decisions must be made to achieve the developers' specific goals, such as compliance with system-related and business-related constraints, which will vary from one implementation to another. Moreover, it will be appreciated that such a development effort might be complex and time-consuming, but would nevertheless be a routine undertaking for those of ordinary skill in the art having the benefit of this disclosure. It is also expressly noted that, although described herein largely in terms of use in spinal surgery, the surgical system and related methods described herein are suitable for use in any number of additional procedures, surgical or otherwise, wherein assessing the health of the spinal cord and/or various other nerve tissue may prove beneficial.

[0011] A surgeon operable neurophysiology system 10 is described herein and is capable of performing a number of neurophysiological and/or guidance assessments at the direction of the surgeon (and/or other members of the surgical staff). By way of example only, Figs. 1-2 illustrate the basic components of the neurophysiology system 10. The system comprises a control unit 12 (including a main display 34 preferably equipped with a graphical user interface (GUI) and a processing unit 36 that collectively contain the essential processing capabilities for controlling the system 10), a patient module 14, a stimulation accessory (e.g. a stimulation probe 16, stimulation clip 18 for connection to various surgical instruments, an inline stimulation hub 20, and stimulation electrodes 22), and a plurality of recording electrodes 24 for detecting electrical potentials. The stimulation clip 18 may be used to connect any of a variety of surgical instruments to the system 10, including, but not necessarily limited to a pedicle access needle 26, k-wire 27, tap 28, dilator(s) 30, tissue retractor 32, etc. One or more secondary feedback devices (e.g. secondary display 46) may also be provided for additional expression of output to a user and/or receiving input from the user.

[0012] In one embodiment, the neurophysiology system 10 may be configured to execute any of the functional modes including, but not necessarily limited to, static pedicle integrity testing ("Basic Stimulated EMG"), dynamic pedicle integrity testing ("Dynamic Stimulated EMG"), nerve proximity detection ("XLIF®"), neuromuscular pathway assessment ("Twitch Test"), motor evoked potential monitoring ("MEP manual" and MEP Automatic"), somatosensory evoked potential monitoring ("SSEP"), non-evoked monitoring ("Free-run EMG") and surgical navigation ("Navigated Guidance"). The neurophysiology system 10 may also be configured for performance in any of the lumbar, thoracolumbar, and cervical regions of the spine.

[0013] The basis for performing many of these functional modes (e.g. Basic Stimulated EMG, Dynamic Stimulated EMG, XLIF, MEP manual, and MEP automatic, and Twitch Test) is the assessment of evoked responses of the various muscles myotomes monitored by the system 10 in relation to a stimulation signal transmitted by the system 10 (via patient module 14). This is illustrated in FIG. 3-5, wherein FIG. 5 illustrates the resulting EMG waveform of a monitored myotome in response to one of the example stimulation signals represented in FIG. 3 and FIG. 4. The EMG responses provide a quantitative measure of the nerve depolarization caused by the electrical stimulus. One way to characterize the EMG response is by a peak-to-peak voltage of $V_{pp} = V_{max} - V_{min}$, as shown in Fig. 5. Nerve tissues have characteristic threshold current levels (I_{thresh}) at which they will depolarize and result in a detectable muscle activity. Below this threshold current level, a stimulation signal will not evoke a significant EMG response. According to one embodiment, a significant EMG response may be defined as having a V_{pp} of approximately 100uV. Thus, the lowest stimulation current necessary to evoke an EMG response of the threshold voltage (V_{thresh}), 100uV in this example, may be called I_{thresh} . The greater the degree of electrical communication between a stimulation signal and a nerve, the lower I_{thresh} will be. Conversely, the lower the degree of electrical communication a stimulation signal and a nerve, the greater I_{thresh} will be. Thus determining I_{thresh} and/or monitoring changes in I_{thresh} over time, may provide valuable information when nerve tissues are at risk during a surgical procedure, as will be discussed in more detail below. By way of example, an excessively high I_{thresh} or an increase over a previous measurement during MEP may indicate a problem in the spinal cord inhibiting transmission (communication) of the stimulation signal to the nerve. Meanwhile, during the Basic Stimulated EMG or Dynamic Stimulated EMG modes and the XLIF mode, a low T_{thresh} value may indicate a breach in the pedicle allowing the electrical signal to transmit through the pedicle, or the close proximity of a nerve to the stimulation source, respectively. Armed with the useful information conveyed by T_{thresh} , the surgeon may detect a problem or potential problem early and then act to avoid and/or mitigate the problem.

The neurophysiology system 10 may quickly and accurately determine I_{thresh} under the direction and operation of the surgeon (if desired) and convey the useful information I_{thresh} contains in a simple and easily comprehensible manner for interpretation by the surgeon.

[0014] Before further addressing I_{thresh} and the various functional modes of the surgical system 10, the hardware components and features of the system 10 will be describe in further detail. The control unit 12 of the neurophysiology system 10, illustrated by way of example only in Fig. 6, includes a main display 34 and a processing unit 36, which collectively contain the essential processing capabilities for controlling the neurophysiology system 10. The main display 34 is preferably equipped with a graphical user interface (GUI) capable of graphically communicating information to the user and receiving instructions from the user. The processing unit 36 contains computer hardware and software that commands the stimulation source (e.g. patient module 14, Figs. 7-9), receives digital and/or analog signals and other information from the patient module 14, processes EMG and SSEP response signals, and displays the processed data

to the operator via the display 34. The primary functions of the software within the control unit 12 include receiving user commands via the touch screen main display 34, activating stimulation in the appropriate mode (Basic Stimulated EMG, Dynamic Stimulated EMG, XLIF, MEP automatic, MEP manual, SSEP, and Twitch Test), processing signal data according to defined algorithms, displaying received parameters and processed data, and monitoring system status. According to one example embodiment, the main display 34 may comprise a 15" LCD display equipped with suitable touch screen technology and the processing unit 36 may comprise a 2GHz. The processing unit 36 shown in Fig. 6 further includes a powered USB port 38 for connection to the patient module 14, a media drive 40 (e.g. CD, CD-RW, DVD, DVD-RW, etc...), a network port, wireless network card, and a plurality of additional ports 42 (e.g. USB, IEEE 1394, infrared, etc...) for attaching additional accessories, such as for example only, navigated guidance sensors, auxiliary stimulation anodes, and external devices (e.g. printer, keyboard, mouse, etc...). Preferably, during use the control unit 12 sits near the surgical table but outside the surgical field, such as for example, on a table top or a mobile stand. It will be appreciated, however, that if properly draped and protected, the control unit 12 may be located within the surgical (sterile) field.

[0015] The patient module 14, shown by way of example only in FIGS. 7-9, is communicatively linked to the control unit 12. In this embodiment the patient module 14 is communicatively linked with and receives power from the control unit 12 via a USB data cable 44. However, it will be appreciated that the patient module 14 may be supplied with its own power source and other known data cables, as well as wireless technology, may be utilized to establish communication between the patient module 14 and control unit 12. The patient module 14 contains a digital communications interface to communicate with the control unit 12, as well as the electrical connections to all recording and stimulation electrodes, signal conditioning circuitry, stimulator drive and steering circuitry, and signal conditioning circuitry required to perform all of the functional modes of the neurophysiology system 10, including but not necessarily limited to Basic Stimulated EMG, Dynamic Stimulated EMG, XLIF®, Twitch Test, MEP Manual and MEP Automatic, and SSEP. A display (e.g. an LCD screen) may be provided on the face of the patient module 14, and maybe utilized for showing simple status readouts (for example, results of a power on test, the electrode harnesses attached, and impedance data, etc...) or more procedure related data (for example, a stimulation threshold result, current stimulation level, selected function, etc ...). The patient module 14 may be positioned near the patient in the sterile field during surgery. By way of example, the patient module 14 may be attached to bed rail with the aid of a hook 48 attached to, or forming a part of, the patient module 14 casing.

[0016] With reference to Figs. 7-9, patient module 14 comprises a multitude of ports and indicators for connecting and verifying connections between the patient module 14 and other system components. A control unit port 50 is provided for data and power communication with the control unit 12, via USB data cable 44 as previously described. There are four accessory ports 52 provided for connecting up to the same number of surgical accessories, including, but not necessarily limited to, stimulation probe 16, stimulation clip 18, inline stimulation hub 20, and navigated guidance sensor (or tilt sensor) 54. The accessory ports 52 include a stimulation cathode and transmit digital communication signals, tri-color LED drive signals, button status signals, identification signals, and power between the patient module 14 and the attached accessory. A pair of anode ports 56, preferably comprising 2 wire DIN connectors, may be used to attach auxiliary stimulation anodes should it become desirable or necessary to do so during a procedure. A pair of USB ports 58 are connected as a USB hub to the control unit 12 and may be used to make any number of connections, such as for example only, a portable storage drive.

[0017] As soon as a device is plugged into any one of ports 50, 52, 56, or 58, the neurophysiology system 10 automatically performs a circuit continuity check to ensure the associated device will work properly. Each device forms a separate closed circuit with the patient module such that the devices may be checked independent of each other. If one device is not working properly the device may be identified individually while the remaining devices continue indicate their valid status. An indicator LED is provided for each port to convey the results of the continuity check to the user. Thus, according to the example embodiment of Figs. 7-9, the patient module 14 includes one control unit indicator 60, four accessory indicators 62, two anode indicators 64, and two USB indicators 66. According to a preferred embodiment, if the system detects an incomplete circuit during the continuity check, the appropriate indicator will turn red alerting the user that the device might not work properly. On the other hand, if a complete circuit is detected, the indicator will appear green signifying that the device should work as desired. Additional indicator LEDs are provided to indicate the status of the system and the MEP stimulation. The system indicator 68 will appear green when the system is ready and red when the system is not ready. The MEP stim indicator 70 lights up when the patient module is ready to deliver and MEP stimulation signal. In one embodiment, the MEP stim indicator 68 appears yellow to indicate a ready status.

[0018] To connect the array of recording electrodes 24 and stimulation electrodes 22 utilized by the system 10, the patient module 14 also includes a plurality of electrode harness ports. In the embodiment shown, the patient module 14 includes an EMG/MEP harness port 72, SSEP harness port 74, and an Auxiliary harness port 76 (for expansion and/or custom harnesses). Each harness port 72, 74, and 76 includes a shaped socket 78 that corresponds to a matching shaped connector 82 on the appropriate electrode harness 80. In addition, the neurophysiology system 10 may preferably employ a color code system wherein each modality (e.g. EMG, EMG/MEP, and SSEP) has a unique color associated with it. By way of example only and as shown herein, EMG monitoring (including, screw tests, detection, and nerve retractor) may be associated with the color green, MEP monitoring with the color blue, and SSEP monitoring may be

associated with the color orange. Thus, each harness port 72, 74, 76 is marked with the appropriate color which will also correspond to the appropriate harness 80. Utilizing the combination of the dedicated color code and the shaped socket/connector interface simplifies the setup of the system, reduces errors, and can greatly minimize the amount of pre-operative preparation necessary. The patient module 14, and especially the configuration of quantity and layout of the various ports and indicators, has been described according to one example embodiment of the present invention. It should be appreciated, however, that the patient module 14 could be configured with any number of different arrangements without departing from the scope of the invention.

[0019] As mentioned above, to simplify setup of the system 10, all of the recording electrodes 24 and stimulation electrodes 22 that are required to perform one of the various functional modes (including a common electrode 23 providing a ground reference to pre-amplifiers in the patient module 14, and an anode electrode 25 providing a return path for the stimulation current) are bundled together and provided in single electrode harness 80, as illustrated, by way of example only, in Fig. 10. Depending on the desired function or functions to be used during a particular procedure, different groupings of recording electrodes 24 and stimulation electrodes 22 may be required. By way of example, the SSEP function requires more stimulating electrodes 22 than either the EMG or MEP functions, but also requires fewer recording electrodes than either of the EMG and MEP functions. To account for the differing electrode needs of the various functional modes, the neurophysiology system 10 may employ different harnesses 80 tailored for the desired modes. According to one embodiment, three different electrode harnesses 80 may be provided for use with the system 10, an EMG harness, an EMG/MEP harness, and an SSEP harness.

[0020] At one end of the harness 80 is the shaped connector 82. As described above, the shaped connector 82 interfaces with the shaped socket 72, 74, or 76 (depending on the functions harness 80 is provided for). Each harness 80 utilizes a shaped connector 82 that corresponds to the appropriate shaped socket 72, 74, 76 on the patient module 14. If the shapes of the socket and connector do not match the harness 80, connection to the patient module 14 cannot be established. According to one embodiment, the EMG and the EMG/MEP harnesses both plug into the EMG/MEP harness port 72 and thus they both utilized the same shaped connector 82. By way of example only, Figs. 11A-11C illustrate the various shape profiles used by the different harness ports 72, 74, 76 and connectors 82. Fig. 11A illustrates the half circular shape associated with the EMG and EMG/MEP harness and port 72. Fig. 11B illustrates the rectangular shape utilized by the SSEP harness and port 74. Finally, Fig. 11C illustrates the triangular shape utilized by the Auxiliary harness and port 76. Each harness connector 82 includes a digital identification signal that identifies the type of harness 80 to the patient module 14. At the opposite end of the electrode harness 80 are a plurality of electrode connectors 102 linked to the harness connector 82 via a wire lead. Using the electrode connector 102, any of a variety of known electrodes may be used, such as by way of example only, surface dry gel electrodes, surface wet gel electrodes, and needle electrodes.

[0021] To facilitate easy placement of scalp electrodes used during MEP and SSEP modes, an electrode cap 81, depicted by way of example only in Fig. 13A may be used. The electrode cap 81 includes two recording electrodes 23 for SSEP monitoring, two stimulation electrodes 22 for MEP stimulation delivery, and an anode 23. Graphic indicators may be used on the electrode cap 81 to delineate the different electrodes. By way of example, lightning bolts may be used to indicate a stimulation electrode, a circle within a circle may be used to indicate recording electrodes, and a stepped arrow may be used to indicate the anode electrode. The anode electrode wire is colored white to further distinguish it from the other electrodes and is significantly longer than the other electrode wires to allow placement of the anode electrode on the patient's shoulder. The shape of the electrode cap 81 may also be designed to simplify placement. By way of example only, the cap 81 has a pointed end that may point directly toward the patient's nose when the cap 81 is centered on the head in the right orientation. A single wire may connect the electrode cap 81 to the patient module 14 or electrode harness 80, thereby decreasing the wire population around the upper regions of the patient. Alternatively, the cap 81 may be equipped with a power supply and a wireless antenna for communicating with the system 10. Fig. 13B illustrates another example embodiment of an electrode cap 83 similar to cap 81. Rather than using graphic indicators to differentiate the electrodes, colored wires may be employed. By way of example, the stimulation electrodes 22 are colored yellow, the recording electrodes 24 are gray, and the anode electrode 23 is white. The anode electrode is seen here configured for placement on the patient's forehead.

[0022] To further simplify the process of placing the required electrodes, the end of each wire lead next to the electrode connector 102 may be tagged with a label 86 that shows or describes the proper positioning of the electrode on the patient. The label 86 preferably demonstrates proper electrode placement graphically and textually. As shown in Fig. 12, the label may include, a graphic image showing the relevant body portion 88 and the precise electrode position 90. Textually, the label 86 may indicate the side 100 and muscle (or anatomic location) 96 for placement, the function of the electrode (e.g. stimulation, recording channel, anode, and reference - not shown), the patient surface (e.g. anterior or posterior), the spinal region 94, and the type of monitoring 92 (e.g. EMG, MEP, SSEP, by way of example, only). According to one embodiment (set forth by way of example only), the electrode harnesses 80 are designed such that the various electrodes may be positioned about the patient (and preferably labeled accordingly) as described in Table 1 for Lumbar EMG, Table 2 for Cervical EMG, Table 3 for Lumbar/Thoracolumbar EMG and MEP, Table 4 for Cervical EMG and

EP 2 142 087 B1

MEP, and Table 5 for SSEP:

Table 1: Lumbar EMG

5
10
15
20

Electrode Type	Electrode Placement	Spinal Level
Ground	Upper Outer Thigh	-
Anode	Latissimus Dorsi	-
Stimulation	Knee	-
Recording	Left Tibialis Anterior	L4, L5
Recording	Left Gastroc. Medialis	S1, S2
Recording	Left Vastus Medialis	L2, L3, L4
Recording	Left Biceps Femoris	L5, S1, S2
Recording	Right Biceps Femoris	L5, S1, S2
Recording	Right Vastus Medialis	L2, L3, L4
Recording	Right Gastroc. Medialis	S1, S2
Recording	Right Tibialis Anterior	L4, L5

Table 2: Cervical EMG

25
30
35
40
45

Electrode Type	Electrode Placement	Spinal Level
Ground	Shoulder	-
Anode	Mastoid	-
Stimulation	Inside Elbow	-
Recording	Left Triceps	C7, C8
Recording	Left Flexor Carpi Radialis	C6, C7, C8
Recording	Left Deltoid	C5, C6
Recording	Left Trapezius	C3, C4
Recording	Left Vocal Cord	RLN
Recording	Right Vocal Cord	RLN
Recording	Right Trapezius	C3, C4
Recording	Right Deltoid	C5, C6
Recording	Right Flexor Carpi Radialis	C6, C7, C8
Recording	Right Triceps	C7, C8

Table 3: Lumbar/Thoracolumbar EMG + MEP

50
55

Electrode Type	Electrode Placement	Spinal Level
Ground	Upper Outer Thigh	-
Anode	Latissimus Dorsi	-
Stimulation	Knee	-
Recording	Left Tibialis Anterior	L4, L5
Recording	Left Gastroc. Medialis	S1, S2
Recording	Left Vastus Medialis	L2, L3, L4

EP 2 142 087 B1

(continued)

Electrode Type	Electrode Placement	Spinal Level
Recording	Left Biceps Femoris	L5, S1, S2
Recording	Left APB-ADM	C6, C7, C8, T1
Recording	Right APB-ADM	C6, C7, C8, T1
Recording	Right Biceps Femoris	L5, S1, S2
Recording	Right Vastus Medialis	L2, L3, L4
Recording	Right Gastroc. Medialis	S1, S2
Recording	Right Tibialis Anterior	L4, L5

Table 4: Cervical EMG + MEP

Electrode Type	Electrode Placement	Spinal Level
Ground	Shoulder	-
Anode	Mastoid	-
Stimulation	Inside Elbow	-
Recording	Left Tibialis Anterior	L4, L5
Recording	Left Flexor Carpi Radialis	C6, C7, C8
Recording	Left Deltoid	C5, C6
Recording	Left Trapezius	C3, C4
Recording	Left APB-ADM	C6, C7, C8, T1
Recording	Left Vocal Cord	RLN
Recording	Right Vocal Cord	RLN
Recording	Right APB-ADM	C6, C7, C8, T1
Recording	Right Trapezius	C3, C4
Recording	Right Deltoid	C5, C6
Recording	Right Flexor Carpi Radialis	C6, C7, C8
Recording	Right Tibialis Anterior	L4, L5

Table 5: SSEP

Electrode Type	Electrode Placement	Spinal Level
Ground	Shoulder	-
Stimulation	Left Post Tibial Nerve	-
Stimulation	Left Ulnar Nerve	-
Stimulation	Right Post Tibial Nerve	-
Stimulation	Right Ulnar Nerve	-
Recording	Left Popliteal Fossa	-
Recording	Left Erb's	-
Recording	Left Scalp Cp3	-
Recording	Right Popliteal Fossa	-

(continued)

Electrode Type	Electrode Placement	Spinal Level
Recording	Right Erb's	-
Recording	Right Scalp Cp4	-
Recording	Center ScalpFpz	-
Recording	Center Scalp Cz	-
Recording	Center Cervical Spine	-

[0023] The patient module 14 is configured such that the neurophysiology system 10 may conduct an impedance test under the direction of the control unit 12 of all electrodes once the system is set up and the electrode harness is connected and applied to the patient. After choosing the appropriate spinal site upon program startup (described below), the user is directed to an electrode test. Fig. 14A illustrates, by way of example only, a box diagram setting forth the features of the electrode test as implemented on an electrode test screen 104. Fig. 14B illustrates, by way of example only, a graphical implementation capturing the features described in Fig. 14A, according to one example embodiment of the GUI. The electrode test screen 104 includes a human figure depiction with positioned electrodes 108. A harness indicator 109 displays which harness is in use. For each electrode on the harness 80 in use there is a channel button 110. This includes the common 25 and anode 23electrods which are both independently checked for impedance. To accomplish this, the anode 23 and common 25 are both provided as dual electrodes. At least one of the anode leads on the anode electrode is reversible. During the impedance check the reversible anode lead switches to a cathode such that the impedance between the leads can be measured. When the impedance test is complete the reversible lead switches back to an anode. The channel button 110 may be labeled with the muscle or coverage area of the corresponding electrode. Selecting the channel button 110 will disable the channel. Disabled channels will not be tested for impedance and they will not be monitored for responses or errors unless reactivated. Upon selection of a start button 106 (entitled "Run Electrode Test"), the system 10 tests each electrode individually to determine the impedance value. If the impedance is determined to be within acceptable limits, the channel button 110 and electrode depiction on the human figure 108 turn green. If the impedance value for any electrode is not determined to be acceptable, the associated channel button 110 and electrode depiction turn red, alerting the user. Once the test is complete, selecting the Accept button 112 will open the main monitoring screen of system 10. In order to individually check the impedance of the both the anode electrode 25 and common electrode 23 may be individually tested for impedance.

[0024] The neurophysiology system 10 may utilize various stimulation accessories to deliver stimulation signals to a stimulation target site, such as a hole formed or being formed in a pedicle and/or tissue surrounding a surgical access corridor. One such stimulation accessory is the stimulation probe 16, illustrated, by way of example, in Figs. 15-17. The probe 16 includes an ergonomic handle 116 and an insulated probe member 118 with an uninsulated ball end 120. Preferably, the entire stimulation probe 16 is disposable and a new probe may be provided for each use. The handle 116 includes an integrated stimulation button 122. Depressing the stimulation button 122 while active in an appropriate functional mode (e.g. Basic Stimulated EMG) is effective to activate stimulation in the selected functional mode. The finger indentions 126 and curved under surface 128 permit the probe 16 to rest comfortably in the hands of the user.

[0025] Also situated in the handle 116 of probe 16 is a multi-color LED light 124. The LED 124 may be used to indicate the connectivity status of the probe. This may be done preferably, in addition to the connectivity status indicated from the accessory indicator 62. When the probe 16 is connected to the patient module 14 stimulation is active the LED 124 may appear predetermined color (e.g. purple in this embodiment) to indicate the stimulation status. Additionally, the LED 124 may be used to indicate the status of a threshold (I_{thresh}) result. By way of example, and as will be further described below, if a threshold value is determined to be within a predetermined safe range, the probe LED 124 may appear the color green indicating relative safety. If the determined threshold value falls within a predetermined unsafe range, the probe LED 124 may appear the color red indicating potential danger. Finally, if the threshold result is between the predetermined safe and unsafe ranges, the probe LED may appear yellow indicating caution. The probe handle 116 may also be equipped to emit audible tones related to the determined threshold results. For example, the pitch of the sound may change in response to different threshold levels. Thus, when a determined threshold is in the safe (Green) range then a low pitch tone may be emitted. When the threshold result is in-between the safe and unsafe levels (Yellow) the sound may have a higher pitch. A still higher pitch may be emitted when the threshold result is in the unsafe (Red) range. Alternatively, a different sound volume may indicate different safety levels. In still another alternative, different sounds (e.g. ping, bell, siren etc...) may be produced for each safety level. The probe handle 116 may also be equipped to deliver tactile feedback to the user. For example, the probe handle 116 may vibrate in response to a determined stimulation threshold. The vibration of the probe 116 may operate in similar fashion to that of the sound function just

described. That is, the vibration frequency and/or intensity may be altered depending on the safety level of the corresponding threshold result. Any of the vibration frequency, intensity, pulse pattern, etc... may be variable depending upon the stimulation result so as to provide an indication to the user of the determined threshold. The stimulation probe 116 includes a connector 126 that may be plugged into one of the accessory ports 62 on the patient module 14. Similar to the electrode connector 82, the probe connector 126 includes an identification signal that identifies the probe 116 to the patient module 14.

[0026] Figs. 18-20 illustrate an example embodiment of another stimulation accessory, this one in the form of a stimulation clip 18 that permits the system 10 to deliver stimulation signals through various surgical instruments already used during the surgical procedure. By way of example only, the coupling device 18 may connect the neurophysiology system 10 with instruments including, but not necessarily limited to a pedicle access needle 26, a tap 28, dilator 30, tissue retractor 32, and k-wire 27. The stimulation clip 18 utilizes a spring-loaded plunger 128 to hold the surgical tool and transmit the stimulation signal thereto. The plunger 128 is composed of a conductive material such as metal. A nonconductive housing 130 partially encases the plunger 128 about its center. Extending from the housing 130 is an end plate 132 that hooks the surgical instrument. A spring (not shown) is disposed within the housing 130 such that in a natural or "closed" state the plunger 128 is situated in close proximity to the endplate 132. Exerting a compressive force on the spring (such as by pulling on the thumb grip 134) causes a gap between the end plate 132 and the plunger 128 to widen to an "open" position (shown in Figs. 18-19), thereby allowing insertion of a surgical tool between the end plate 132 and plunger 128. Releasing the thumb grip 134 allows the spring to return to a "closed" position, causing the plunger 132 to move laterally back towards the endplate such that a force is exerted upon the surgical instrument and thereby holding it in place between the endplate 132 and the plunger 128. The clip 18 further includes a button module 129 containing an activation button 131 for initiating stimulation. The button module 129 is set apart from the body of the clip 18 and they are linked by an integrated wire. An accessory port 133 is located next to the button 131 on the button module 129, thus minimizing the number of wires connecting back to the patient module 14 and outside the sterile field. Clip 18 is equipped with three LEDs 135, 137, and 139. LED 135 is associated with the accessory port 133 and LED 137 is associated with the clip 18 to indicate which of the two is stimulating. The LEDs 135 and 137 may appear purple when stimulation is active. When a stimulation result is determined the associated LED 135 or 137 may appear either red (if the result meets a predetermined potentially unsafe value), green (if the result meets a predetermined safe value), or yellow (if the result is in between the safe and potentially unsafe values). A third LED 139 is contained within the thumb grip 134, which will appear red, yellow, or green depending on the threshold result. The clip 18 connects to one of the accessory ports 62 on the patient module 14 via a connector 136. The connector 136 includes an identification signal that identifies it to the patient module 14.

[0027] As mentioned above, the neurophysiology monitoring system 10 may include a secondary display, such as for example only, the secondary display 46 illustrated in Figs. 21-22. The secondary display 46 may be configured to display some or all of the information provided on main display 34. The information displayed to the user on the secondary display 34 may include, but is not necessarily limited to, alpha-numeric and/or graphical information regarding any of the selected function modes (e.g. Basic Stimulated EMG, Dynamic Stimulated EMG, XLIF, MEP automatic, MEP manual, SSEP, and Twitch Test, and Free run), attached accessories (e.g. stimulation probe 16, stimulation clip 18, tilt sensor 54), electrode harness or harnesses attached, impedance test results, myotome/EMG levels, stimulation levels, history reports, selected parameters, test results, etc... In one embodiment, secondary display 46 may be configured to receive user input in addition to its display function. The secondary display 46 can thus be used as an alternate control point for the system 10. The control unit 12 and secondary display 46 may be linked such that input may be received on from one display without changing the output shown on the other display. This would allow the surgeon to maintain focus on the patient and test results while still allowing other members of the OR staff to manipulate the system 10 for various purposes (e.g. inputting annotations, viewing history, etc...). The secondary display 46 may be battery powered. Advantageously, the secondary display 46 may be positioned inside the sterile field as well as outside the sterile field. For positioning within the sterile field a disposable sterile case 47 may be provided to house the display. Alternatively, the display 46 may be sterile bagged. Both the sterile case 47 and the secondary display 46 may be mounted to a pole, bed frame, light fixture, or other apparatus found near and/or in the surgical field. It is further contemplated that multiple secondary displays 46 may be linked to the control unit 12. This may effectively distribute neurophysiology information and control throughout the operating room. By way of example, a secondary display 46 may also be provided for the anesthesiologist. This may be particularly useful in providing the anesthesiologist with results from the Twitch Test and providing reminders about the use of paralytics, which may adversely affect the accuracy of the neurophysiology system 10. Wired or wireless technology may be utilized to link the secondary display 46 to the control unit 12.

[0028] Having described an example embodiment of the system 10 and the hardware components that comprise it, the neurophysiological functionality and methodology of the system 10 will now be described in further detail. Various parameters and configurations of the neuromonitoring system 10 may depend upon the target location, i.e. spinal region, of the surgical procedure. In one embodiment, upon starting the system 10 the software will automatically open to the startup screen, illustrated by way of example only, in block chart form in Fig. 23A and graphical form in Fig. 23B. The

startup screen includes a profile selection window 160 from which the user may select from one of the standard profiles (e.g. "Standard Cervical," "Standard Thoracolumbar," and "Standard Lumbar") or any custom profiles that have been previously saved to the system. Selecting a profile configures the system 10 to the parameters assigned for the selected region or to custom parameters saved under the profile. The availability of different function modes depends upon the profile selected. By way of example only, selecting the cervical and thoracolumbar spinal regions may automatically configure the options to allow selection of the Twitch Test, Basic and Dynamic Stimulated EMG Tests, MEP Auto, MEP Manual, SSEP, and Navigated Guidance modes, while selecting the lumbar region may automatically configure the options to allow selection of the Twitch Test, Basic and Dynamic Stimulated EMG Tests, XLIF®, and Nerve Retractor modes. Default parameters associated with the various function modes may also depend on the profile selected; for example, the characteristics of the stimulation signal delivered by the system 10 may vary depending on the profile. By way of example, the stimulation signal utilized for the Stimulated EMG modes may be configured differently when a lumbar profile is selected versus when one of a thoracolumbar profile and a cervical profile. As previously described above, each of the hardware components includes an identification tag that allows the control unit 12 to know exactly what devices are hooked up and ready for operation. In one embodiment, profiles may only be available for selection if the appropriate devices (e.g. proper electrode harness 80 and stimulation accessories) are connected and/or ready for operation. Alternatively, the software could bypass the startup screen and jump straight to one of the functional modes based on the accessories and/or harnesses it knows are plugged in. The ability to select a profile based on standard parameters, and especially on customized preferences, may save significant time at the beginning of a procedure and provides for monitoring availability right from the start. Moving on from the startup screen, the software advances directly to an electrode test screen and impedance tests, which are performed on every electrode as discussed above. When an acceptable impedance test has been completed, the system 10 is ready to begin monitoring and the software advances to a monitoring screen from which the neurophysiological monitoring functions of the system 10 are performed.

[0029] The information displayed on the monitoring screen may include, but is not necessarily limited to, alpha-numeric and/or graphical information regarding any of the functional modes (e.g., Basic Stimulated EMG, Dynamic Stimulated EMG, XLIF, MEP automatic, MEP manual, SSEP, Twitch Test, and Free run), attached accessories (e.g. stimulation probe 16, stimulation clip 18, tilt sensor 54), electrode harness or harnesses attached, impedance test results, myotome/EMG levels, stimulation levels, history reports, selected parameters, test results, etc... In one embodiment, set forth by way of example only, this information displayed on a main monitoring screen may include, but is not necessarily limited to the following components as set forth in Table 6:

Table 6

Screen Component	Description
Patient Image/Electrode layout	An image of the human body or relevant portion thereof showing the electrode placement on the body, with labeled channel number tabs on each side (1-4 on the left and right). Left and right labels will show the patient orientation. The channel number tabs may be highlighted or colored depending on the specific function being performed.
Myotome & Level Names	A label to indicate the Myotome name and corresponding Spinal Level(s) associated with the channel of interest.
Test Menu	A hideable menu bar for selecting between the available functional modes.
Device Bar	A hideable bar displaying icons and/or names of devices connected to the patient module.
Display Area	Shows procedure-specific information including stimulation results.
Color Indication	Enhances stimulation results with a color display of green, yellow, or red corresponding to the relative safety level determined by the system.
Stimulation Bar	A graphical stimulation indicator depicting the present stimulation status (i.e. on or off and stimulation current level), as well as providing for starting and stopping stimulation
Event Bar	A hideable bar that shows the last up to a selected number of previous stimulation results, provides for annotation of results, and a chat dialogue box for communicating with remote participants.
EMG waveforms	EMG waveforms may be optionally displayed on screen along with the stimulation results.

[0030] With reference to Figs. 24A-24B, various features of the monitoring screen 200 of the GUI will now be described. It should be appreciated that while FIGS. 24A-24B depict the monitoring screen 200 while the selected function is the

Twitch Test, the features of monitoring screen 200 apply equally to all the functions. Result-specific data is displayed in a center result area 202. A large color saturated numeric value 210 is used to show the threshold result. Three different options are provided for showing the stimulation response level. First, the user can view the waveform. Second, a likeness of the color coded electrode harness label 86 may be shown on the display. Third, the color coded label 212 may be integrated with a body image. On one side of center result area 202 there is a collapsible device menu 202. The device menu displays a graphic representation of each device connected to the patient module 14. If a device is selected from the device menu 202, an impedance test may be initiated. Opposite the device menu 202 there is a collapsible test menu 204. The test menu 204 highlights each test that is available under the operable setup profile and may be used to navigate between functions. A collapsible stimulation bar 206 indicates the current stimulation status and provides start and stop stimulation buttons (not shown) to activate and control stimulation. The collapsible event bar 208 stores all the stimulation test results obtained throughout a procedure so that the user may review the entire case history from the monitoring screen. Clicking on a particular event will open a note box and annotations may be entered and saved with the response, for later inclusion in a procedure report chronicling all nerve monitoring functions conducted during the procedure as well as the results of nerve monitoring. In one embodiment the report may be printed immediately from one or more printers located in the operating room or copied to any of a variety of memory devices known in the prior art, such as, by way of example only, a floppy disk, and/or USB memory stick. The system 10 may generate either a full report or a summary report depending on the particular needs of the user. In one embodiment, the identifiers used to identify the surgical accessories to the patient module may also be encoded to identify their lot number or other identifying information. As soon as the accessory is identified, the lot number may be automatically added to the report. Alternatively, hand held scanners can be provided and linked to the control unit 12 or patient module 14. The accessory packaging may be scanned and again the information may go directly to the procedure report. The event bar 208 also houses a chat box feature when the system 10 is connected to a remote monitoring system to allow a user in the operating room to contemporaneously communicate with a person performing the associated neuromonitoring in a remote location.

[0031] From a profile setting screen 154, illustrated by way of example only in Fig. 37, custom profiles can be created and saved. Beginning with one of the standard profiles, parameters may be altered by selecting one of the audio 168, site selection 170, test selection 172, and waveform scaling 174 buttons and making the changes until the desired parameters are set. By way of example only, profiles may be generated and saved for particular procedures (e.g. ACDF, XLIF, and Decompression) or for particular individuals. Clicking on each button will display the parameter options specific to the selected button in a parameter window 176. By way of example only, by selecting the audio button 168 both the system audio and Free Run audio may be adjusted. Selecting the site selection button 170 allows the opportunity to change from the site selected initially. Adjusting the site selection of the profile may alter the options available. By way of example, if the user changes the site selection from cervical to lumbar, the MEP function may no longer be selectable as an option. From within the test selection area, function specific parameters for all available test functions (based on site selection, available devices, etc...) may be accessed and set according to need. One option that is available for multiple functions under the test selection button is the ability to select from three different viewing options. The user may choose to see results displayed in numeric form, on a body panel, and on a label that reflects the labels associated with each electrode, or any combination of the three. The user may also choose to see the actual waveforms. Selecting the waveform scaling button 174 allows the user to adjust the scale on which waveforms are displayed. Profiles may be saved directly on the control unit 12 or they may be saved to a portable memory device.

[0032] The functions performed by the neuromonitoring system 10 may include, but are not necessarily limited to, the Twitch Test, Free-run EMG, Basic Stimulated EMG, Dynamic Stimulated EMG, XLIF®, Nerve Retractor, MEP Auto, MEP manual, and SSEP modes, all of which will be described briefly below. The system 10 further includes a navigated guidance function that will also be described below. The Twitch Test mode is designed to assess the neuromuscular pathway via the so-called "train-of-four test" to ensure the neuromuscular pathway is free from muscle relaxants prior to performing neurophysiology-based testing, such as bone integrity (e.g. pedicle) testing, nerve detection, and nerve retraction. This is described in greater detail within PCT Patent App. No. PCT/US2005/036089, entitled "System and Methods for Assessing the Neuromuscular Pathway Prior to Nerve Testing," filed October 7, 2005. The Basic Stimulated EMG Dynamic Stimulated EMG tests are designed to assess the integrity of bone (e.g. pedicle) during all aspects of pilot hole formation (e.g., via an awl), pilot hole preparation (e.g. via a tap), and screw introduction (during and after). These modes are described in greater detail in PCT Patent App. No. PCT/US02/35047 entitled "System and Methods for Performing Percutaneous Pedicle Integrity Assessments," filed on October 30, 2002, and PCT Patent App. No. PCT/US2004/025550, entitled "System and Methods for Performing Dynamic Pedicle Integrity Assessments," filed on August 5, 2004. The XLIF mode is designed to detect the presence of nerves during the use of the various surgical access instruments of the neuromonitoring system 10, including the pedicle access needle 26, k-wire 42, dilator 44, and retractor assembly 70. This mode is described in greater detail within PCT Patent App. No. PCT/US2002/22247, entitled "System and Methods for Determining Nerve Proximity, Direction, and Pathology During Surgery," filed on July 11, 2002. The Nerve Retractor mode is designed to assess the health or pathology of a nerve before, during, and after retraction of the nerve during a surgical procedure. This mode is described in greater detail within PCT Patent App. No.

PCT/US2002/30617, entitled "System and Methods for Performing Surgical Procedures and Assessments," filed on Sept. 25, 2002. The MEP Auto and MEP Manual modes are designed to test the motor pathway to detect potential damage to the spinal cord by stimulating the motor cortex in the brain and recording the resulting EMG response of various muscles in the upper and lower extremities. The SSEP function is designed to test the sensory pathway to detect potential damage to the spinal cord by stimulating peripheral nerves inferior to the target spinal level and recording the action potential from sensors superior to the spinal level. The MEP Auto, MEP manual, and SSEP modes are described in greater detail within PCT Patent App. No. PCT/US2006/003966, entitled "System and Methods for Performing Neurophysiologic Assessments During Spine Surgery," filed on February 2, 2006. The Navigated Guidance function is designed to facilitate the safe and reproducible use of surgical instruments and/or implants by providing the ability to determine the optimal or desired trajectory for surgical instruments and/or implants and monitor the trajectory of surgical instruments and/or implants during surgery. This mode is described in greater detail within PCT Patent App. No. PCT/US2007/11962, entitled "Surgical Trajectory Monitoring System and Related Methods," filed on July 30, 2007. These functions will be explained now in brief detail.

[0033] The neuromonitoring system 10 performs neuromuscular pathway (NMP) assessments, via Twitch Test mode, by electrically stimulating a peripheral nerve (preferably the Peroneal Nerve for lumbar and thoracolumbar applications and the Median Nerve for cervical applications) via stimulation electrodes 22 contained in the applicable electrode harness and placed on the skin over the nerve or by direct stimulation of a spinal nerve using a surgical accessory such as the probe 116. Evoked responses from the muscles innervated by the stimulated nerve are detected and recorded, the results of which are analyzed and a relationship between at least two responses or a stimulation signal and a response is identified. The identified relationship provides an indication of the current state of the NMP. The identified relationship may include, but is not necessarily limited to, one or more of magnitude ratios between multiple evoked responses and the presence or absence of an evoked response relative to a given stimulation signal or signals. With reference to FIGS. 24A-24B details of the test indicating the state of the NMP and the relative safety of continuing on with nerve testing are conveyed to the surgeon via GUI display 34. On the monitoring screen 200 utilized by the various functions performed by the system 10, function specific data is displayed in a center result area 202. The results may be shown as a numeric value 210, a highlighted label corresponding to the electrode labels 86, or (in the case of twitch test only) a bar graph of the stimulation results. On one side of center result area 202 is a collapsible device menu 202. The device menu displays a graphic representation of each device connected to the patient module 14. Opposite the device menu 202 there is a collapsible test menu 204. The test menu 204 highlights each test that is available under the operable setup profile and may be used to navigate between functions. A collapsible stimulation bar 206 indicates the current stimulation status and provides start and stop stimulation buttons (not shown) to activate and control stimulation. The collapsible event bar 208 stores all the stimulation test results obtained throughout a procedure. Clicking on a particular event will open a note box and annotations may be entered and saved with the response, for later inclusion in a procedure report. The event bar 208 also houses a chat box feature when the system 10 is connected to a remote monitoring system as described above. Within the result area 202 the twitch test specific results may be displayed.

[0034] The neuromonitoring system 10 may test the integrity of pedicle holes (during and/or after formation) and/or screws (during and/or after introduction) via the Basic Stimulation EMG and Dynamic Stimulation EMG tests. To perform the Basic Stimulation EMG a test probe 116 is placed in the screw hole prior to screw insertion or placed on the installed screw head and a stimulation signal is applied. The insulating character of bone will prevent the stimulation current, up to a certain amplitude, from communicating with the nerve, thus resulting in a relatively high I_{thresh} , as determined via the basic threshold hunting algorithm described below. However, in the event the pedicle wall has been breached by the screw or tap, the current density in the breach area will increase to the point that the stimulation current will pass through to the adjacent nerve roots and they will depolarize at a lower stimulation current, thus I_{thresh} will be relatively low. The system described herein may exploit this knowledge to inform the practitioner of the current I_{thresh} of the tested screw to determine if the pilot hole or screw has breached the pedicle wall.

[0035] In Dynamic Stim EMG mode, test probe 116 may be replaced with a clip 18 which may be utilized to couple a surgical tool, such as for example, a tap member 28 or a pedicle access needle 26, to the neuromonitoring system 10. In this manner, a stimulation signal may be passed through the surgical tool and pedicle integrity testing can be performed while the tool is in use. Thus, testing may be performed during pilot hole formation by coupling the access needle 26 to the neuromonitoring system 10, and during pilot hole preparation by coupling the tap 28 to the system 10. Likewise, by coupling a pedicle screw to the neuromonitoring system 10 (such as via pedicle screw instrumentation), integrity testing may be performed during screw introduction.

[0036] In both Basic Stimulation EMG mode and Dynamic Stimulation EMG mode, the signal characteristics used for testing in the lumbar testing may not be effective when monitoring in the thoracic and/or cervical levels because of the proximity of the spinal cord to thoracic and cervical pedicles. Whereas a breach formed in a pedicle of the lumbar spine results in stimulation being applied to a nerve root, a breach in a thoracic or cervical pedicle may result in stimulation of the spinal cord instead, but the spinal cord may not respond to a stimulation signal the same way the nerve root would. To account for this, the surgical system 10 is equipped to deliver stimulation signals having different characteristics

based on the region selected. By way of example only, when the lumbar region is selected, stimulation signals for the stimulated EMG modes comprise single pulse signals (see Fig. 3). On the other hand, when the thoracic and cervical regions are selected the stimulation signals may be configured as multipulse signals (see Fig. 4).

5 **[0037]** Stimulation results (including but not necessarily limited to at least one of the numerical I_{thresh} value and color coded safety level indication) and other relevant data are conveyed to the user on at least main display 34, as illustrated in FIGS. 25A-25B and 26A-26B. FIGS. 25A-25B illustrate the monitoring screen 200 with the Basic Stimulation EMG test selected. FIGS. 26A-26B illustrate the monitoring screen 200 with the Dynamic Stimulation EMG test selected. In one embodiment of the various screw test functions (e.g. Basic and Dynamic), green corresponds to a threshold range of greater than 10 milliamps (mA), a yellow corresponds to a stimulation threshold range of 7-10 mA, and a red corresponds to a stimulation threshold range of 6 mA or below. EMG channel tabs may be selected via the touch screen display 26 to show the I_{thresh} of the corresponding nerves. Additionally, the EMG channel possessing the lowest I_{thresh} may be automatically highlighted and/or colored to clearly indicate this fact to the user.

10 **[0038]** The neuromonitoring system 10 may perform nerve proximity testing, via the XLIF mode, to ensure safe and reproducible access to surgical target sites. Using the surgical access components 26-32, the system 10 detects the existence of neural structures before, during, and after the establishment of an operative corridor through (or near) any of a variety of tissues having such neural structures which, if contacted or impinged, may otherwise result in neural impairment for the patient. The surgical access components 26-32 are designed to bluntly dissect the tissue between the patient's skin and the surgical target site. Dilators of increasing diameter, which are equipped with one or more stimulating electrodes, are advanced towards the target site until a sufficient operating corridor is established to advance retractor 32 to the target site. As the dilators are advanced to the target site electrical stimulation signals are emitted via the stimulation electrodes. The stimulation signal will stimulate nerves in close proximity to the stimulation electrode and the corresponding EMG response is monitored. As a nerve gets closer to the stimulation electrode, the stimulation current required to evoke a muscle response decreases because the resistance caused by human tissue will decrease, and it will take less current to cause nervous tissue to depolarize. I_{thresh} is calculated, using the basic threshold hunting algorithm described below, providing a measure of the communication between the stimulation signal and the nerve and thus giving a relative indication of the proximity between access components and nerves. An example of the monitoring screen 200 with XLIF mode active is depicted in FIGS. 27A-27B. In a preferred embodiment, a green or safe level corresponds to a stimulation threshold range of 10 milliamps (mA) or greater, a yellow level denotes a stimulation threshold range of 5-9 mA, and a red level denotes a stimulation threshold range of 4 mA or below.

20 **[0039]** The neuromonitoring system 10 performs assessments of spinal cord health using one or more of MEP Auto, MEP Manual, and SSEP modes. In MEP modes, stimulation signals are delivered to the Motor Cortex via patient module 14 and resulting EMG responses are detected from various muscles in the upper and lower extremities. An increase in I_{thresh} from an earlier test to a later test may indicate a degradation of spinal cord function. Likewise, the absence of a significant EMG response to a given I_{stim} on a channel that had previously reported a significant response to the same or lesser I_{stim} is also indicative of a degradation in spinal cord function. These indicators are detected by the system in the MEP modes and reported to the surgeon. In MEP Auto mode the system determines the I_{thresh} baseline for each channel corresponding to the various monitored muscles, preferably early in the procedure, using the multi-channel algorithm described. Throughout the procedure subsequent tests may be conducted to again determine I_{thresh} for each channel. The difference between the resulting I_{thresh} values and the corresponding baseline are computed by the system 10 and compared against predetermined "safe" and "unsafe" difference values. The I_{thresh} , baseline, and difference values are displayed to the user, along with any other indicia of the safety level determined (such as a red, yellow, green color code), on the display 34, as illustrated in FIGS. 28A-28B. In MEP Manual mode, the user selects the stimulation current level and the system reports whether or not the stimulation signal evokes a significant response on each channel. Stimulation results may be shown on the display 34 in the form of "YES" and "NO" responses, or other equivalent indicia, as depicted in FIG. 29A-29B. Using either mode the surgeon may thus be alerted to potential complications with the spinal cord and any corrective actions deemed necessary may be undertaken at the discretion of the surgeon.

25 **[0040]** In SSEP mode, the neuromonitoring system 10 stimulates peripheral sensory nerves that exit the spinal cord below the level of surgery and then measures the electrical action potential from electrodes located on the nervous system tract superior to the surgical target site. To accomplish this, stimulation electrodes 22 may be placed on the skin over the desired peripheral nerve (such as by way of example only, the Posterior Tibial nerve and/or the Ulnar nerve) and recording electrodes 23 are positioned on the recording sites (such as, by way of example only, C2 vertebra, scalp, Erb's point, and pop fossa) and stimulation signals are delivered from the patient module 14. Damage in the spinal cord may disrupt the transmission of the signal up the cord resulting in a weakened or delayed signal at the recording site. The system 10 determines differences in amplitude and latency between a signal response and a baseline signal response. The differences are compared against predetermined "safe" and "unsafe" levels and the results are displayed on display 34 as seen in the exemplary screen view illustrated in FIG. 30.

30 **[0041]** The neuromonitoring system 10 may also conduct free-run EMG monitoring while the system is in any of the above-described modes. Free-run EMG monitoring continuously listens for spontaneous muscle activity that may be

indicative of potential danger. The system 10 may automatically cycle into free-run monitoring after 5 seconds (by way of example only) of inactivity. Initiating a stimulation signal in the selected mode will interrupt the free-run monitoring until the system 10 has again been inactive for five seconds, at which time the free-run begins again.

[0042] The neuromonitoring system 10 may also perform a navigated guidance function. The navigated guidance feature may be used by way of example only, to ensure safe and reproducible pedicle screw placement by monitoring the axial trajectory of surgical instruments used during pilot hole formation and/or screw insertion. Preferably, EMG monitoring may be performed simultaneously with the navigated guidance feature. To perform the navigated guidance and angle-measuring device (hereafter "tilt sensor") 54 is connected to the patient module 14 via one of the accessory ports 62. The tilt sensor measures its angular orientation with respect to a reference axis (such as, for example, "vertical" or "gravity") and the control unit displays the measurements. Because the tilt sensor is attached to a surgical instrument the angular orientation of the instrument, maybe determined as well, enabling the surgeon to position and maintain the instrument along a desired trajectory during use. In general, to orient and maintain the surgical instrument along a desired trajectory during pilot hole formation, the surgical instrument is advanced to the pedicle (through any of open, mini-open, or percutaneous access) while oriented in the zero-angle position. The instrument is then angulated in the sagittal plane until the proper cranial-caudal angle is reached. Maintaining the proper cranial-caudal angle, the surgical instrument may then be angulated in the transverse plane until the proper medial-lateral angle is attained. Once the control unit 12 indicates that both the medial-lateral and cranial caudal angles are matched correctly, the instrument may be advanced into the pedicle to form the pilot hole, monitoring the angular trajectory of the instrument until the hole formation is complete.

[0043] The control unit 12 may communicate any of numerical, graphical, and audio feedback corresponding to the orientation of the tilt sensor in the sagittal plane (cranial-caudal angle) and in the transverse plane (medial-lateral angle). The medial-lateral and cranial-caudal angle readouts may be displayed simultaneously and continuously while the tilt sensor is in use, or any other variation thereof (e.g. individually and/or intermittently). Fig. 31 illustrates, by way of example only, one embodiment of a GUI screen for the Navigated Guidance function. The angular orientation of the instrument is displayed along with a color coded targeting scheme to help the user find the desired angle.

[0044] To obtain I_{thresh} and take advantage of the useful information it provides, the system 10 identifies and measures the peak-to-peak voltage (V_{pp}) of each EMG response corresponding to a given stimulation current (I_{stim}). Identifying the true V_{pp} of a response may be complicated by the existence of stimulation and/or noise artifacts which may create an erroneous V_{pp} measurement. To overcome this challenge, the neuromonitoring system 10 may employ any number of suitable artifact rejection techniques such as those shown and described in full in the above referenced co-pending and commonly assigned PCT App. Ser. No. PCT/US2004/0255500, entitled "System and Methods for Performing Dynamic Pedicle Integrity Assessments," filed on August 5, 2004. Upon measuring V_{pp} for each EMG response, the V_{pp} information is analyzed relative to the corresponding stimulation current (I_{stim}) in order to identify the minimum stimulation current (I_{Thresh}) capable of resulting in a predetermined V_{pp} EMG response. The determination of I_{Thresh} may be accomplished via any of a variety of suitable algorithms or techniques.

[0045] FIGS. 32A-32D illustrate, by way of example only, the principles of a threshold hunting algorithm used to quickly find I_{thresh} . The method for finding I_{thresh} utilizes a bracketing method and a bisection method. The bracketing method quickly finds a range (bracket) of stimulation currents that must contain I_{thresh} and the bisection method narrows the bracket until I_{thresh} is known within a specified accuracy. If the stimulation current threshold, I_{thresh} , of a channel exceeds a maximum stimulation current, that threshold is considered out of range.

[0046] FIG. 32B illustrates the bracketing feature of the threshold hunting algorithm. Stimulation begins at a minimum stimulation current, such as (by way of example only) 1mA. It will be appreciated that the relevant current values depend in part on the function performed (e.g. high currents are used for MEP and low currents are generally used for other functions) and the current values described here are for purposes of example only and may in actuality be adjusted to any scale. The level of each subsequent stimulation is doubled from the preceding stimulation level until a stimulation current recruits (i.e. results in an EMG response with a V_{pp} greater or equal to V_{thresh}). The first stimulation current to recruit (8 mA in FIG. 32B), together with the last stimulation current to have not recruited (4 mA in FIG. 32B), forms the initial bracket.

[0047] FIGS. 32C-32D illustrate the bisection feature of the threshold hunting algorithm. After the threshold current I_{thresh} has been bracketed (FIG. 32B), the initial bracket is successively reduced via bisection to a predetermined width, such as (by way of example only) 0.25 mA. This is accomplished by applying a first bisection stimulation current that bisects (i.e. forms the midpoint of) the initial bracket (6 mA in FIG. 32C). If this first bisection stimulation current recruits, the bracket is reduced to the lower half of the initial bracket (e.g. 4 mA and 6 mA in FIG. 32C). If this first bisection stimulation current does not recruit, the bracket is reduced to the upper half of the initial bracket (e.g. 6 mA and 8 mA in FIG. 32C). This process is continued for each successive bracket until I_{thresh} is bracketed by stimulation currents separated by the predetermined width (which, in this case, is 0.25 mA). In this example shown, this would be accomplished by applying a second bisection stimulation current (forming the midpoint of the second bracket, or 5 mA in this example). Because this second bisection stimulation current is below I_{thresh} , it will not recruit. As such, the second bracket will be reduced to the upper half thereof (5 mA to 6 mA), forming a third bracket. A third bisection stimulation current forming

the mid-point of the third bracket (5.50 mA in this case) will then be applied. Because this third bisection stimulation current is below I_{thresh} , it will not recruit. As such, the third bracket will be reduced to the upper half thereof (5.50 mA to 6 mA), forming a fourth bracket. A fourth bisection stimulation current forming the mid-point of the fourth bracket (5.75 mA in this case) will then be applied. Because the fourth bisection stimulation current is above I_{thresh} , it will recruit. The final bracket is therefore between 5.50mA and 5.75 mA. Due to the "response" or recruitment at 5.50 mA and "no response" or lack of recruitment at 5.75 mA, it can be inferred that I_{thresh} is within this range. In one embodiment, the midpoint of this final bracket may be defined as I_{thresh} , however, any value falling within the final bracket may be selected as I_{thresh} without departing from the scope of the present invention. Depending on the active mode, the algorithm may stop after finding I_{thresh} for the first responding channel (i.e. the channel with the lowest I_{thresh}) or the bracketing and bisection steps may be repeated for each channel to determine I_{thresh} for each channel. In one embodiment, this multiple channel I_{thresh} determination may be accomplished by employing the additional steps of the multi-channel threshold detection algorithm, described below.

[0048] Additionally, in the "dynamic" functional modes, including, but not necessarily limited to Dynamic Stimulation EMG and XLIF, the system may continuously update the stimulation threshold level and indicate that level to the user. To do so, the threshold hunting algorithm does not repeatedly determine the I_{thresh} level anew, but rather, it determines whether stimulation current thresholds are changing. This is accomplished, as illustrated in FIG. 32D, by a monitoring phase that involves switching between stimulations at lower and upper ends of the final bracket. If the threshold has not changed then the lower stimulation current should not evoke a response, while the upper end of the bracket should. If either of these conditions fail, the bracket is adjusted accordingly. The process is repeated for each of the active channels to continue to assure that each threshold is bracketed. If stimulations fail to evoke the expected response three times in a row, then the algorithm transitions back to the bracketing state in order to reestablish the bracket. In the event a change in I_{thresh} is detected during the monitoring phase, the user may be alerted immediately via the screen display and/or audio feedback. By way of example only, the color shown on the display corresponding to the previous I_{thresh} can be altered to a neutral color (e.g. black, grey, etc...) as soon as the change in I_{thresh} is detected but before the new I_{thresh} value is determined. If an audio tone is used to represent a particular safety level, the tone can be ceased as soon as the change is detected. Once the new I_{thresh} value is determined the color and/or audio tone can be altered again to signify the value.

[0049] In an embodiment of the invention, rather than beginning by entering the bracketing phase at the minimum stimulation current and bracketing upwards until I_{thresh} is bracketed, the threshold hunting algorithm may begin by immediately determining the appropriate safety level and then entering the bracketing phase. The algorithm may accomplish this by initiating stimulation at one or more of the boundary current levels. By way of example only, and with reference to FIG. 33, the algorithm may begin by delivering a stimulation signal at the boundary between the unsafe (e.g. red) and caution (e.g. yellow) levels. If the safety level is not apparent after the first stimulation, the algorithm may stimulate again at the boundary between the caution (e.g. yellow) and safe (e.g. green) levels. Once the safety level is known (i.e. after the first stimulation if the safety level is red, or, after the second stimulation if the safety level is yellow or green) the screen display may be updated to the appropriate color and/or coded audio signals may be emitted. As the screen display is updated, the algorithm may transition to the bracketing and bisection phases to determine the actual I_{thresh} value. When the I_{thresh} value is determined the display may be updated again to reflect the additional information. In dynamic modes, if the monitoring phase detects a change in I_{thresh} , the algorithm will again stimulate at the boundary level(s) as necessary and update the color and/or audio signals before transitioning to the bracketing and bisection phases to determine the new I_{thresh} .

[0050] For some functions, such as (by way of example) MEP, it may be desirable to obtain I_{thresh} for each active channel each time the function is performed. This is particularly advantageous when assessing changes in I_{thresh} over time as a means to detect potential problems (as opposed to detecting an I_{thresh} below a predetermined level determined to be safe, such as in the Stimulated EMG modes). While I_{thresh} can be found for each active channel using the algorithm as described above, it requires a potentially large number of stimulations, each of which is associated with a specific time delay, which can add significantly to the response time. Done repeatedly, it could also add significantly to the overall time required to complete the surgical procedure, which may present added risk to the patient and added costs. To overcome this drawback, a preferred embodiment of the neuromonitoring system 10 boasts a multi-channel threshold hunting algorithm so as to quickly determine I_{thresh} for each channel while minimizing the number of stimulations and thus reduce the time required to perform such determinations.

[0051] The multi-channel threshold hunting algorithm reduces the number stimulations required to complete the bracketing and bisection steps when I_{thresh} is being found for multiple channels. The multi-channel algorithm does so by omitting stimulations for which the result is predictable from the data already acquired. When a stimulation signal is omitted, the algorithm proceeds as if the stimulation had taken place. However, instead of reporting an actual recruitment result, the reported result is inferred from previous data. This permits the algorithm to proceed to the next step immediately, without the time delay associated with a stimulation signal.

[0052] Regardless of what channel is being processed for I_{thresh} , each stimulation signal elicits a response from all

active channels. That is to say, every channel either recruits or does not recruit in response to a stimulation signal (again, a channel is said to have recruited if a stimulation signal evokes an EMG response deemed to be significant on that channel, such as V_{pp} of approximately 100 μ V). These recruitment results are recorded and saved for each channel. Later, when a different channel is processed for I_{thresh} , the saved data can be accessed and, based on that data, the

algorithm may omit a stimulation signal and infer whether or not the channel would recruit at the given stimulation current. **[0053]** There are two reasons the algorithm may omit a stimulation signal and report previous recruitment results. A stimulation signal may be omitted if the selected stimulation current would be a repeat of a previous stimulation. By way of example only, if a stimulation current of 1mA was applied to determine I_{thresh} for one channel, and a stimulation at 1mA is later required to determine I_{thresh} for another channel, the algorithm may omit the stimulation and report the previous results. If the specific stimulation current required has not previously been used, a stimulation signal may still be omitted if the results are already clear from the previous data. By way of example only, if a stimulation current of 2mA was applied to determine I_{thresh} for a previous channel and the present channel did not recruit, when a stimulation at 1 mA is later required to determine I_{thresh} for the present channel, the algorithm may infer from the previous stimulation that the present channel will not recruit at 1mA because it did not recruit at 2mA. The algorithm may therefore omit the stimulation and report the previous result.

[0054] FIG. 34 illustrates (in flowchart form) a method by which the multi-channel threshold hunting algorithm determines whether to stimulate, or not stimulate and simply report previous results. The algorithm first determines if the selected stimulation current has already been used (step 302). If the stimulation current has been used, the stimulation is omitted and the results of the previous stimulation are reported for the present channel (step 304). If the stimulation current has not been used, the algorithm determines $I_{recruit}$ (step 306) and $I_{norecruit}$ (step 308) for the present channel. $I_{recruit}$ is the lowest stimulation current that has recruited on the present channel. $I_{norecruit}$ is the highest stimulation current that has failed to recruit on the present channel. The algorithm next determines whether $I_{recruit}$ is greater than $I_{norecruit}$ (step 310). An $I_{recruit}$ that is not greater than $I_{norecruit}$ is an indication that changes have occurred to I_{thresh} on that channel. Thus, previous results may not be reflective of the present threshold state and the algorithm will not use them to infer the response to a given stimulation current. The algorithm will stimulate at the selected current and report the results for the present channel (step 312). If $I_{recruit}$ is greater than $I_{norecruit}$, the algorithm determines whether the selected stimulation current is higher than $I_{recruit}$, lower than $I_{norecruit}$, or between $I_{recruit}$ and $I_{norecruit}$ (step 314). If the selected stimulation current is higher than $I_{recruit}$, the algorithm omits the stimulation and reports that the present channel recruits at the specified current (step 316). If the selected stimulation current is lower than $I_{norecruit}$, the algorithm infers that the present channel will not recruit at the selected current and reports that result (step 318). If the selected stimulation current falls between $I_{recruit}$ and $I_{norecruit}$, the result of the stimulation cannot be inferred and the algorithm stimulates at the selected current and reports the results for the present channel (step 312). This method may be repeated until I_{thresh} has been determined for every active channel.

[0055] In the interest of clarity, FIGS. 35A-35C demonstrate use of the multi-channel threshold hunting algorithm to determine I_{thresh} on only two channels. It should be appreciated, however, that the multi-channel algorithm is not limited to finding I_{thresh} for two channels, but rather it may be used to find I_{thresh} for any number of channels, such as (for example) eight channels according to a preferred embodiment of the neuromonitoring system 10. With reference to FIG. 35A, channel 1 has an I_{thresh} to be found of 6.25 mA and channel 2 has an I_{thresh} to be found of 4.25 mA. I_{thresh} for channel 1 is found first as illustrated in FIG. 35B, using the bracketing and bisection methods discussed above. Bracketing begins at the minimum stimulation current (for the purposes of example only) of 1 mA. As this is the first channel processed and no previous recruitment results exist, no stimulations are omitted. The stimulation current is doubled with each successive stimulation until a significant EMG response is evoked at 8 mA. The initial bracket of 4-8 mA is bisected, using the bisection method described above, until the stimulation threshold, I_{thresh} , is contained within a final bracket separated by the selected width or resolution (again .25 mA). In this example, the final bracket is 6 mA-6.25 mA. I_{thresh} may be defined as any point within the final bracket or as the midpoint of the final bracket (6.125 mA in this case). In either event, I_{thresh} is selected and reported as I_{thresh} for channel 1.

[0056] Once I_{thresh} is found for channel 1, the algorithm turns to channel 2, as illustrated in FIG. 35C. The algorithm begins to process channel 2 by determining the initial bracket, which is again 4-8 mA. All the stimulation currents required in the bracketing state were used in determining I_{thresh} for channel 1. The algorithm refers back to the saved data to determine how channel 1 responded to the previous stimulations. From the saved data, the algorithm may infer that channel 2 will not recruit at stimulation currents of 1, 2, and 4 mA, and will recruit at 8 mA. These stimulations are omitted and the inferred results are displayed. The first bisection stimulation current selected in the bisection process (6 mA in this case), was previously used and, as such, the algorithm may omit the stimulation and report that channel 2 recruits at that stimulation current. The next bisection stimulation current selected (5 mA in this case) has not been previously used and, as such, the algorithm must determine whether the result of a stimulation at 5 mA may still be inferred. In the example shown, $I_{recruit}$ and $I_{norecruit}$ are determined to be 6 mA and 4 mA, respectively. Because 5 mA falls in between $I_{recruit}$ and $I_{norecruit}$, the algorithm may not infer the result from the previous data and, as such, the stimulation may not be omitted. The algorithm then stimulates at 5 mA and reports that the channel recruits. The bracket is reduced to the

lower half (making 4.50 mA the next bisection stimulation current). A stimulation current of 4.5 mA has not previously been used and, as such, the algorithm again determines I_{recruit} and $I_{\text{norecruit}}$ (5 mA and 4 mA in this case). The selected stimulation current (4.5 mA) falls in between I_{recruit} and $I_{\text{norecruit}}$ and, as such, the algorithm stimulates at 4.5 mA and reports the results. The bracket now stands at its final width of .25 mA (for the purposes of example only). I_{thresh} may be defined as any point within the final bracket or as the midpoint of the final bracket (4.125 mA in this case). In either event, I_{thresh} is selected and reported as I_{thresh} for channel 2.

[0057] Although the multi-channel threshold hunting algorithm is described above as processing channels in numerical order, it will be understood that the actual order in which channels are processed is immaterial. The channel processing order may be biased to yield the highest or lowest threshold first (discussed below) or an arbitrary processing order may be used. Furthermore, it will be understood that it is not necessary to complete the algorithm for one channel before beginning to process the next channel, provided that the intermediate state of the algorithm is retained for each channel. Channels are still processed one at a time. However, the algorithm may cycle between one or more channels, processing as few as one stimulation current for that channel before moving on to the next channel. By way of example only, the algorithm may stimulate at 10mA while processing a first channel for I_{thresh} . Before stimulating at 20 mA (the next stimulation current in the bracketing phase), the algorithm may cycle to any other channel and process it for the 10 mA stimulation current (omitting the stimulation if applicable). Any or all of the channels may be processed this way before returning to the first channel to apply the next stimulation. Likewise, the algorithm need not return to the first channel to stimulate at 20 mA, but instead may select a different channel to process first at the 20 mA level. In this manner, the algorithm may advance all channels essentially together and bias the order to find the lower threshold channels first or the higher threshold channels first. By way of example only, the algorithm may stimulate at one current level and process each channel in turn at that level before advancing to the next stimulation current level. The algorithm may continue in this pattern until the channel with the lowest I_{thresh} is bracketed. The algorithm may then process that channel exclusively until I_{thresh} is determined, and then return to processing the other channels one stimulation current level at a time until the channel with the next lowest I_{thresh} is bracketed. This process may be repeated until I_{thresh} is determined for each channel in order of lowest to highest I_{thresh} . If I_{thresh} for more than one channel falls within the same bracket, the bracket may be bisected, processing each channel within that bracket in turn until it becomes clear which one has the lowest I_{thresh} . If it becomes more advantageous to determine the highest I_{thresh} first, the algorithm may continue in the bracketing state until the bracket is found for every channel and then bisect each channel in descending order.

[0058] FIG. 36A illustrates a further feature of the threshold hunting algorithm which advantageously provides the ability to further reduce the number of stimulations required to find I_{thresh} when an I_{thresh} value has previously been determined for a specific channel. In the event that a previous I_{thresh} determination exists for a specific channel, the algorithm may begin by merely confirming the previous I_{thresh} rather than beginning anew with the bracketing and bisection methods. The algorithm first determines whether it is conducting the initial threshold determination for the channel or whether there is a previous I_{thresh} determination (step 320). If it is not the initial determination, the algorithm confirms the previous determination (step 322) as described below. If the previous threshold is confirmed, the algorithm reports that value as the present I_{thresh} (step 324). If it is the initial I_{thresh} determination, or if the previous threshold cannot be confirmed, then the algorithm performs the bracketing function (step 326) and bisection function (step 328) to determine I_{thresh} and then reports the value (step 324).

[0059] FIG. 36B illustrates, by way of example only, a method employed by the threshold hunting algorithm for confirming a previous threshold. The confirmation step attempts to ascertain whether I_{thresh} has moved from its last known value. To do this, the algorithm applies two stimulation currents, one at or just above the threshold value and the other just below the threshold value. If the stimulation at or above I_{thresh} recruits and the stimulation just below I_{thresh} does not recruit, then the threshold has not moved and the algorithm may report that value as I_{thresh} and proceed to process another channel. If the stimulation just below I_{thresh} recruits, it may be concluded that I_{thresh} has decreased and likewise if the stimulation at or just above I_{thresh} fails to recruit, it may be concluded that I_{thresh} has increased.

[0060] If I_{thresh} cannot be confirmed, the algorithm enters the bracketing state. Rather than beginning the bracketing state from the minimum stimulation current, however, the bracketing state may begin from the previous I_{thresh} . The bracketing may advance up or down depending on whether I_{thresh} has increased or decreased. By way of example only, if the previous value of I_{thresh} was 4 mA, the confirmation step may stimulate at 4 mA and 3.75 mA. If the stimulation at 4 mA fails to evoke a significant response, it may be concluded that the I_{thresh} has increased and the algorithm will bracket up from 4 mA. When the algorithm enters the bracketing state, the increment used in the confirmation step (i.e..25 mA in this example) is doubled. Thus, in this example, the algorithm stimulates at 4.50 mA. If the channel fails to recruit at this current level, the increment is doubled again (1 mA in this example) and the algorithm stimulates at 5.50 mA. This process is repeated until the maximum stimulation current is reached or the channel recruits, at which time the bisection function may be performed. If, during the confirmation step, the stimulation current just below the previously determined I_{thresh} recruits, it may be concluded that I_{thresh} for that channel has decreased and the algorithm may bracket down from that value (3.75 mA in this case). Thus, in this example, the algorithm would double the increment to .50 mA and stimulate at 3.25 mA. If the channel still recruits at this stimulation current, the increment is doubled again to 1 mA such that the

algorithm stimulates at 2.25 mA. This process is repeated until the minimum stimulation current is reached or the channel fails to recruit, at which time the algorithm may perform the bisection function. When determining I_{thresh} for multiple channels with previously determined I_{thresh} values, this technique may be performed for each channel, in turn, in any order. Again stimulations may be omitted and the algorithm may begin processing a new channel before completing the algorithm for another channel, as described above.

[0061] Although the hunting algorithm is discussed herein in terms of finding I_{thresh} (the lowest stimulation current that evokes a predetermined EMG response), it is contemplated that alternative stimulation thresholds may be useful in assessing the health of the spinal cord or nerve monitoring functions and may be determined by the hunting algorithm. By way of example only, the hunting algorithm may be employed by the system 10 to determine a stimulation voltage threshold, $V_{\text{stim_thresh}}$. This is the lowest stimulation voltage (as opposed to the lowest stimulation current) necessary to evoke a significant EMG response, V_{thresh} . Bracketing, bisection and monitoring states are conducted as described above for each active channel, with brackets based on voltage being substituted for the current based brackets previously described. Moreover, although described above within the context of MEP monitoring, it will be appreciated that the algorithms described herein may also be used for determining the stimulation threshold (current or voltage) for any other EMG related functions, including but not limited to pedicle integrity (screw test), nerve detection, and nerve root retraction.

[0062] While this invention has been described in terms of a best mode for achieving this invention's objectives, it will be appreciated by those skilled in the art that variations may be accomplished in view of these teachings without deviating from the scope of the present invention as defined in the claims. For example, the present invention may be implemented using any combination of computer programming software, firmware or hardware. As a preparatory step to practicing the invention or constructing an apparatus according to the invention, the computer programming code (whether software or firmware) according to the invention will typically be stored in one or more machine readable storage mediums such as fixed (hard) drives, diskettes, optical disks, magnetic tape, semiconductor memories such as ROMs, PROMs, etc., thereby making an article of manufacture in accordance with the invention. The article of manufacture containing the computer programming code is used by either executing the code directly from the storage device, by copying the code from the storage device into another storage device such as a hard disk, RAM, etc. or by transmitting the code on a network for remote execution. As can be envisioned by one of skill in the art, many different combinations of the above may be used.

Claims

1. A system (10) for avoiding harm to neural tissue during surgery, comprising:

an instrument (16) capable of advancement to a surgical target site and configured to deliver a stimulation signal at least one of while advancing to said target site and after reaching said target site; and
 a display (34) for communicating said at least one of nerve proximity and pedicle integrity;
 a processing system (36) programmed with a set of threshold ranges, said set comprising first, second and third threshold ranges, each threshold range corresponding to a respective safety level; **characterized in that** said processing system (36) is configured to direct a first stimulation signal to said instrument at a first magnitude corresponding to a boundary between said first and second threshold ranges, direct a second stimulation signal at a second magnitude corresponding to a boundary between said second and third threshold ranges, and measure the response of nerves depolarized by said stimulation signals to indicate at least one of nerve proximity and pedicle integrity.

2. The system (10) of claim 1, wherein the response of said depolarized nerves is measured by monitoring the EMG waveforms of myotomes associated with said depolarized nerves.

3. The system (10) of claim 1, wherein said system (10) indicates at least one of nerve proximity and pedicle integrity by displaying at least one of the colors of red, yellow, and green.

4. The system (10) of claim 3, wherein said processing system (36) automatically determines a stimulation threshold after displaying said one of red, yellow, and green and augments the display of said one of red, yellow, and green with a numerical value after determining said threshold.

5. The system (10) of claim 1, wherein said instrument (16) is one of a device for forming a hole in a pedicle and a part of a system for establishing an operative corridor through a lateral approach to a spinal surgical target site.

6. The system (10) of claim 5, wherein said instrument (16) is further coupled to an orientation sensor (54) operable

to determine a first angular relationship in a first plane between said sensor (54) and a reference direction and operable to determine a second angular relationship in a second plane between said sensor (54) and said reference direction.

- 5 7. The system (10) of claim 6, wherein said orientation sensor (54) is communicatively linked to said processing system (36) and said processing system (36) communicates information to a user regarding at least one of said determined first and second angular relationships between said sensor (54) and said reference direction.
- 10 8. The system (10) of claim 1, wherein an individualized closed circuit is formed between the instrument (16) and the processing system (36) and at least one of said processing system (36) and said instrument (16) possess an indicator when said closed circuit is formed.
- 15 9. The system (10) of claim 1, comprising a plurality of sensors for measuring said nerve responses, wherein said plurality of sensors are connectable to said processing system (36) through a single connector (82).
- 20 10. The system (10) of claim 9, wherein said single connector (82) comprises an identifier that is recognized by said processing system (36).
- 25 11. The system (10) of claim 10, wherein the identification of said connector (82) alters system parameters employed by said processing system (36).
- 30 12. The system (10) of claim 11, further comprising a plurality of sensors for measuring said nerve responses and wherein the status of said sensors is checked prior to measuring said nerve responses.
- 35 13. The system (10) of claim 12, wherein the status of each of said plurality of sensors is determined independently from the other sensors.
- 40 14. The system (10) of claim 1, wherein said processing system is further configured to: (a) deliver an electrical stimulation signal to the motor cortex of a patient; (b) receive evoked neuromuscular response data from a sensor employed on the patient; (c) assess spinal cord health by identifying a relationship between the stimulation signal and the neuromuscular response; and (d) communicate the relationship between the stimulation signal and the neuromuscular response to a user via at least one of alpha-numeric indicia and audio.
- 45 15. The system (10) of claim 1 wherein said processing system is further configured to: (a) deliver an electrical stimulation signal to a peripheral nerve of the patient; (b) measure an action potential related to said stimulation signal; (c) assess spinal cord health by identifying a relationship between the stimulation signal and the measured action potential; and (d) communicate the relationship between the stimulation signal and the action potential response to a user via at least one of alpha-numeric indicia and audio.

Patentansprüche

- 50 1. System (10) zur Vermeidung von Nervengewebescheiden während Operation, umfassend ein Instrument (16), das in der Lage ist zu einer chirurgischen Zielstelle vorzurücken und gestaltet ist, um während dem Vorrücken zur Zielstelle und/oder nach dem Erreichen der Zielstelle ein Stimulationssignal abzugeben; und eine Anzeige (34) zur Kommunikation der Nervennähe und/oder Pedikel-Integrität, ein Prozessierungssystem (36), das mit einer Reihe von Schwellwertbereichen programmiert ist, wobei die Reihe einen ersten, zweiten und dritten Schwellwertbereich umfasst, wobei jeder Schwellwertbereich einer jeweiligen Sicherheitsebene entspricht, **dadurch gekennzeichnet, dass** das Prozessierungssystem (36) gestaltet ist, um ein erstes Stimulationssignal mit einer ersten Stärke, die einer Grenze zwischen dem ersten und zweiten Schwellwertbereich entspricht, an das Instrument zu leiten, um ein zweites Stimulationssignal mit einer zweiten Stärke, die einer Grenze zwischen dem zweiten und dritten Schwellwertbereich entspricht, zu leiten, und die Antwort der Nerven zu messen, die durch die Simulationssignale depolarisiert wurden, um Nervennähe und/oder Pedikel-Integrität anzugeben.
- 55 2. System (10) nach Anspruch 1, wobei die Antwort der depolarisierten Nerven durch Überwachung der EMG Wellenformen von Myotomen, die den depolarisierten Nerven zugeordnet sind, gemessen wird.

EP 2 142 087 B1

3. System (10) nach Anspruch 1, wobei das System (10) Nervennähe und/oder Pedikel-Integrität durch Anzeigen mindestens einer der Farben rot, gelb, und grün angibt.
- 5 4. System (10) nach Anspruch 3, wobei das Prozessierungssystem (36) automatisch nach Anzeigen des einen von rot, gelb, und grün einen Stimulationsschwellwert bestimmt und die Anzeige des einen von rot, gelb, und grün mit einem numerischen Wert nach Bestimmung des Schwellwertes ergänzt.
- 10 5. System (10) nach Anspruch 1, wobei das Instrument (16) eines ist von einer Vorrichtung, die ein Loch in einem Pedikel bildet und einem Teil eines Systems zur Schaffung eines operativen Korridors durch einen lateralen Zugang zu einer spinalen chirurgischen Zielstelle.
- 15 6. System (10) nach Anspruch 5, wobei das Instrument (16) weiter an einen Orientierungssensor (54) gekoppelt ist, der betreibbar ist, um eine erste Winkelbeziehung in einer ersten Ebene zwischen dem Sensor (54) und einer Referenzrichtung zu bestimmen, und betreibbar ist, um eine zweite Winkelbeziehung in einer zweiten Ebene zwischen dem Sensor (54) und der Referenzrichtung zu bestimmen.
- 20 7. System (10) nach Anspruch 6, wobei der Orientierungssensor (54) kommunikativ mit dem Prozessierungssystem (36) verbunden ist und das Prozessierungssystem (36) Informationen an einen Nutzer kommuniziert, die zumindest eine der bestimmten ersten und zweiten Winkelbeziehung zwischen dem Sensor (54) und der Referenzrichtung betreffen.
- 25 8. System (10) nach Anspruch 1, wobei ein individualisierter geschlossener Kreislauf zwischen dem Instrument (16) und dem Prozessierungssystem (36) gebildet ist und zumindest eines von dem Prozessierungssystem (36) und dem Instrument (16) einen Indikator besitzt, wenn der geschlossene Kreislauf gebildet ist.
- 30 9. System (10) nach Anspruch 1, umfassend eine Mehrzahl von Sensoren zum Messen der Nervenantworten, wobei die Mehrzahl der Sensoren durch einen einzelnen Anschluss (82) zum Prozessierungssystem (36) anschließbar sind.
- 35 10. System (10) nach Anspruch 9, wobei der einzelne Anschluss (82) eine Kennung umfasst, die von dem Prozessierungssystem (36) erkannt wird.
- 40 11. System (10) nach Anspruch 10, wobei die Identifizierung des Anschlusses (82) Systemparameter, die von dem Prozessierungssystem verwendet werden, ändert.
- 45 12. System (10) nach Anspruch 11, weiter umfassend eine Mehrzahl von Sensoren zum Messen der Nervenantworten und wobei der Status der Sensoren vor der Messung der Nervenantworten überprüft wird.
- 50 13. System (10) nach Anspruch 12, wobei der Status von jedem der Mehrzahl der Sensoren unabhängig von den anderen Sensoren bestimmt wird.
- 55 14. System (10) nach Anspruch 1, wobei das Prozessierungssystem weiter gestaltet ist, um: (a) ein elektrisches Stimulationssignal an den motorischen Kortex eines Patienten abzugeben; (b) evozierte neuromuskuläre Antwortdaten von einem Sensor, der an dem Patienten verwendet wird, zu empfangen; (c) den Gesundheitszustand des Rückenmarks durch Identifizieren einer Beziehung zwischen dem Stimulationssignal und der neuromuskulären Antwort zu beurteilen; und (d) die Beziehung zwischen dem Stimulationssignal und der neuromuskulären Antwort durch mindestens eines von alpha-nummerischen Zeichen und Ton an einen Nutzer zu kommunizieren.
15. System (10) nach Anspruch 1, wobei das Prozessierungssystem weiter gestaltet ist, um: (a) ein elektrisches Stimulationssignal an einen peripheralen Nerven des Patienten abzugeben; (b) ein Aktionspotential, das mit dem Stimulationssignal zusammenhängt, zu messen; (c) den Gesundheitszustand des Rückenmarks durch Identifizieren einer Beziehung zwischen dem Stimulationssignal und dem gemessenen Aktionspotential zu beurteilen; und (d) die Beziehungen zwischen dem Stimulationssignal und der Antwort auf das Aktionspotential durch mindestens eines von alpha-nummerischen Zeichen und Ton an einen Nutzer zu kommunizieren.

Revendications

1. Système (10) pour éviter d'endommager un tissu nerveux au cours d'une intervention chirurgicale, comprenant:

un instrument (16) capable d'avancer vers un site chirurgical cible et configuré pour délivrer un signal de stimulation tout en avançant vers ledit site cible et/ou après avoir atteint ledit site cible ; et un écran (34) pour communiquer ladite proximité d'un nerf et/ou ladite intégrité d'un pédicule ; un système de traitement (36) programmé avec un ensemble de plages de seuil, ledit ensemble comprenant des première, deuxième et troisième plages de seuil, chaque plage de seuil correspondant à un niveau de sécurité respectif ;

caractérisé en ce que ledit système de traitement (36) est configuré pour diriger un premier signal de stimulation vers ledit instrument à une première amplitude correspondant à une limite entre lesdites première et deuxième plages de seuil, pour diriger un deuxième signal de stimulation à une deuxième amplitude correspondant à une limite entre lesdites deuxième et troisième plages de seuil, et pour mesurer la réponse de nerfs dépolarisés par lesdits signaux de stimulation pour indiquer la proximité d'un nerf et/ou l'intégrité d'un pédicule.

2. Système (10) de la revendication 1, dans lequel la réponse desdits nerfs dépolarisés est mesurée en surveillant les formes d'onde EMG de myotomes associés auxdits nerfs dépolarisés.
3. Système (10) de la revendication 1, dans lequel ledit système (10) indique la proximité d'un nerf et/ou l'intégrité d'un pédicule en affichant au moins l'une des couleurs rouge, jaune et vert.
4. Système (10) de la revendication 3, dans lequel ledit système de traitement (36) détermine automatiquement un seuil de stimulation après l'affichage de ladite couleur parmi le rouge, le jaune et le vert et augmente l'affichage de ladite couleur parmi le rouge, le jaune et le vert avec une valeur numérique après la détermination dudit seuil.
5. Système (10) de la revendication 1, dans lequel ledit instrument (16) est l'un(e) d'un dispositif pour former un trou dans un pédicule et d'une partie d'un système pour établir un corridor opératoire par une approche latérale à un site chirurgical rachidien cible.
6. Système (10) de la revendication 5, dans lequel ledit instrument (16) est en outre couplé à un capteur d'orientation (54) pouvant fonctionner pour déterminer une première relation angulaire dans un premier plan entre ledit capteur (54) et une direction de référence et pouvant fonctionner pour déterminer une deuxième relation angulaire dans un deuxième plan entre ledit capteur (54) et ladite direction de référence.
7. Système (10) de la revendication 6, dans lequel ledit capteur d'orientation (54) est relié de manière à communiquer avec ledit système de traitement (36) et ledit système de traitement (36) communique des informations à un utilisateur concernant au moins l'une desdites première et deuxième relations angulaires déterminées entre ledit capteur (54) et ladite direction de référence.
8. Système (10) de la revendication 1, dans lequel un circuit fermé individualisé est formé entre l'instrument (16) et le système de traitement (36) et au moins l'un dudit système de traitement (36) et dudit instrument (16) possède un indicateur lorsque ledit circuit fermé est formé.
9. Système (10) de la revendication 1, comprenant une pluralité de capteurs pour mesurer lesdites réponses nerveuses, où ladite pluralité de capteurs peuvent être raccordés audit système de traitement (36) par un raccord unique (82).
10. Système (10) de la revendication 9, dans lequel ledit raccord unique (82) comprend un identifiant qui est reconnu par ledit système de traitement (36).
11. Système (10) de la revendication 10, dans lequel l'identification dudit raccord (82) modifie les paramètres système utilisés par ledit système de traitement (36).
12. Système (10) de la revendication 11, comprenant en outre une pluralité de capteurs pour mesurer lesdites réponses nerveuses et où l'état desdits capteurs est vérifié avant de mesurer lesdites réponses nerveuses.
13. Système (10) de la revendication 12, dans lequel l'état de chacun de ladite pluralité de capteurs est déterminé indépendamment des autres capteurs.
14. Système (10) de la revendication 1, dans lequel ledit système de traitement est en outre configuré : (a) pour délivrer un signal de stimulation électrique au cortex moteur d'un patient ; (b) pour recevoir des données de réponse neuromusculaire évoquée à partir d'un capteur utilisé sur le patient ; (c) pour évaluer l'état de la moelle épinière en

identifiant une relation entre le signal de stimulation et la réponse neuromusculaire ; et (d) pour communiquer la relation entre le signal de stimulation et la réponse neuromusculaire à un utilisateur par l'intermédiaire d'indices alphanumériques et/ou par audio.

- 5 **15.** Système (10) de la revendication 1, dans lequel ledit système de traitement est en outre configuré : (a) pour délivrer un signal de stimulation électrique à un nerf périphérique du patient ; (b) pour mesurer un potentiel d'action relatif audit signal de stimulation ; (c) pour évaluer l'état de la moelle épinière en identifiant une relation entre le signal de stimulation et le potentiel d'action mesuré ; et (d) pour communiquer la relation entre le signal de stimulation et la réponse de potentiel d'action à un utilisateur par l'intermédiaire d'indices alphanumériques et/ou par audio.

10

15

20

25

30

35

40

45

50

55

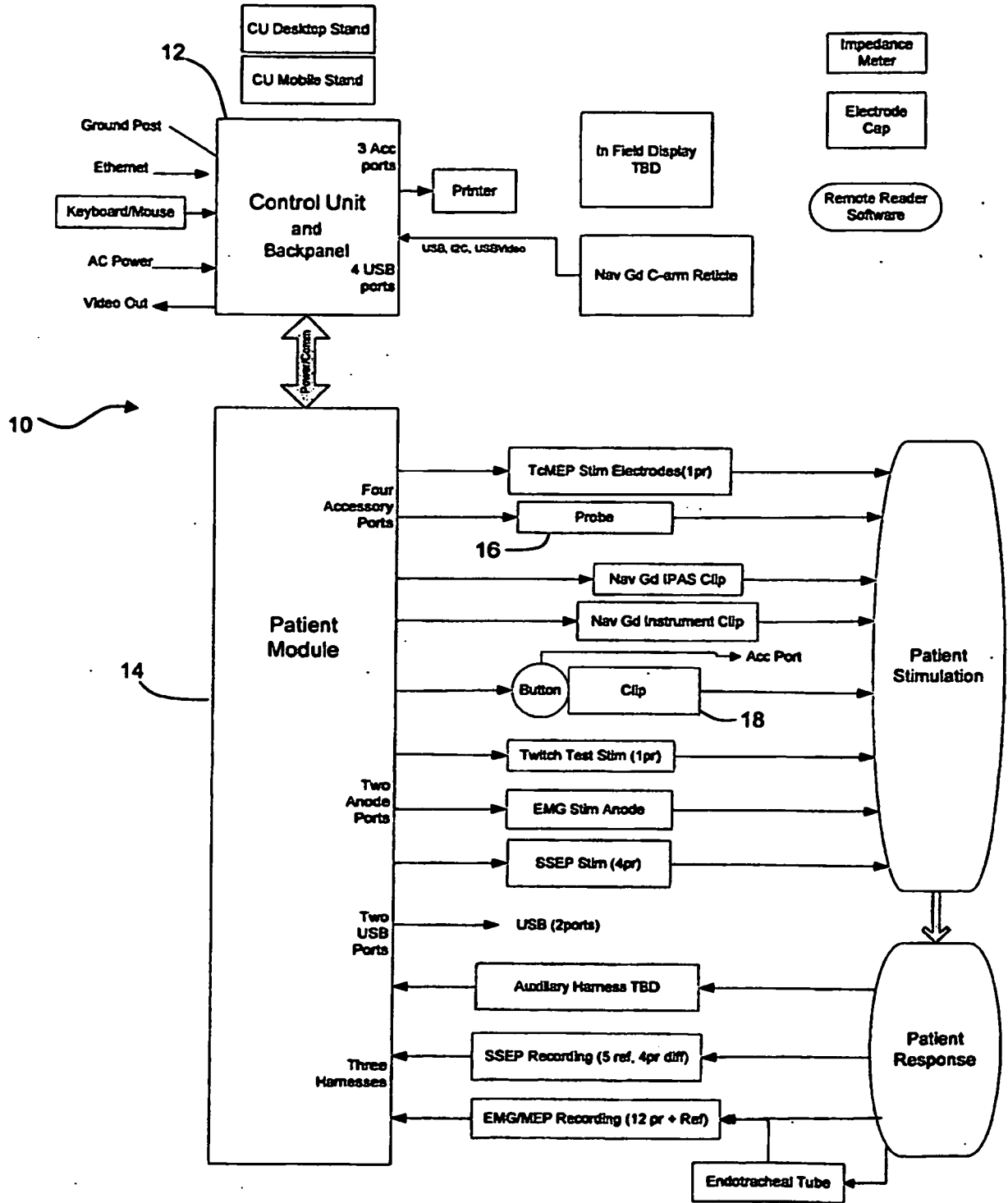
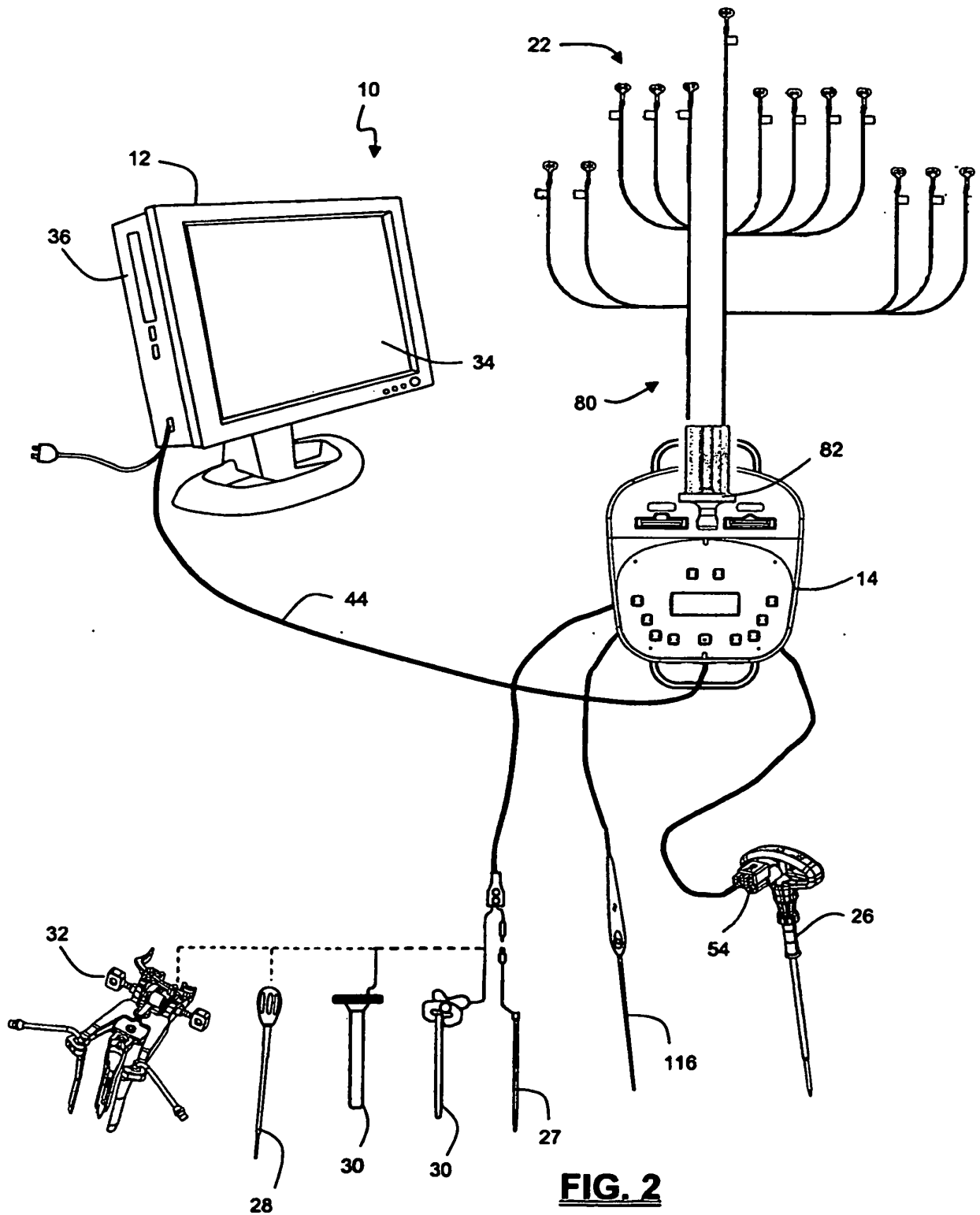

FIG. 1



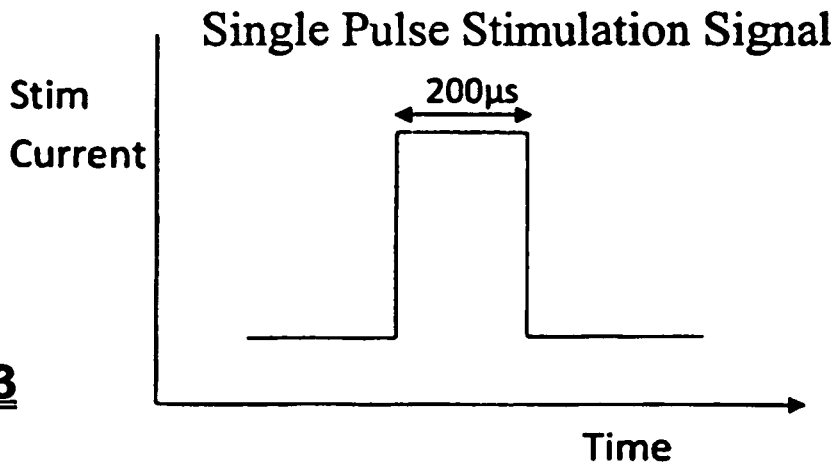

FIG. 3

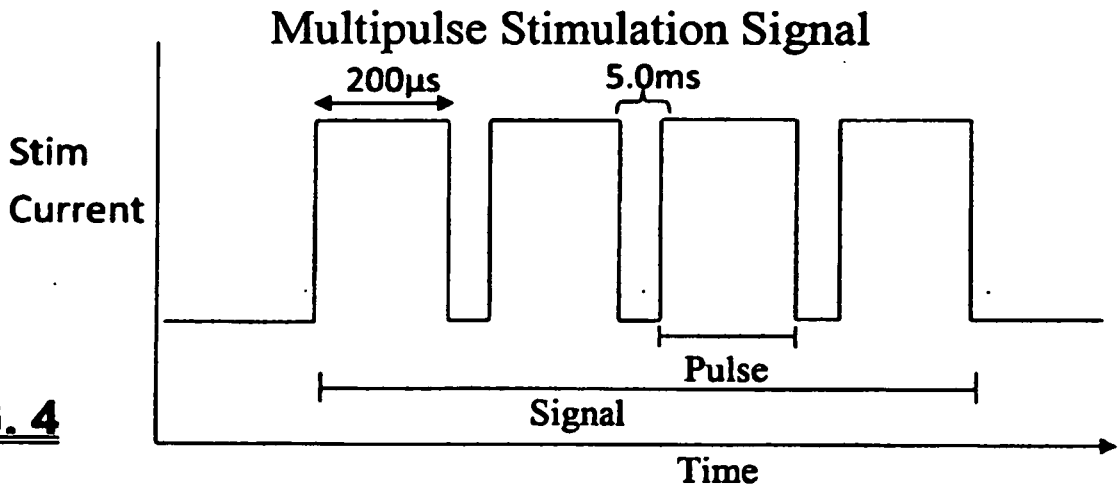

FIG. 4

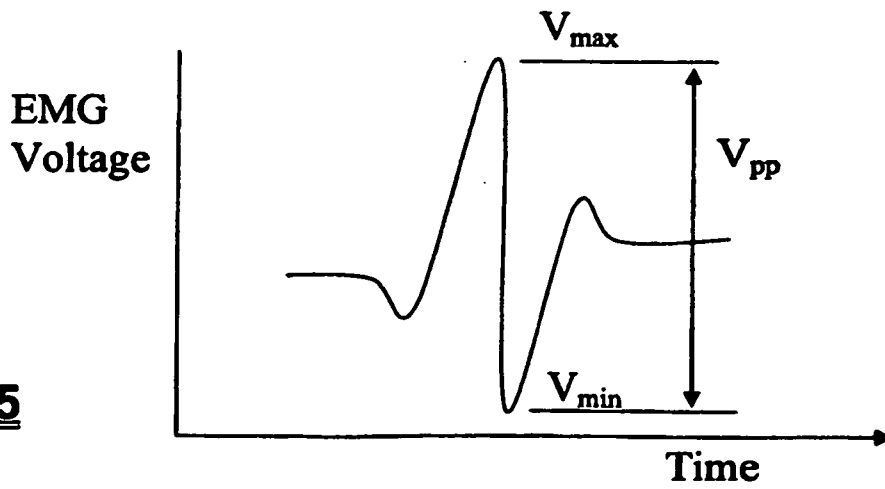

FIG. 5

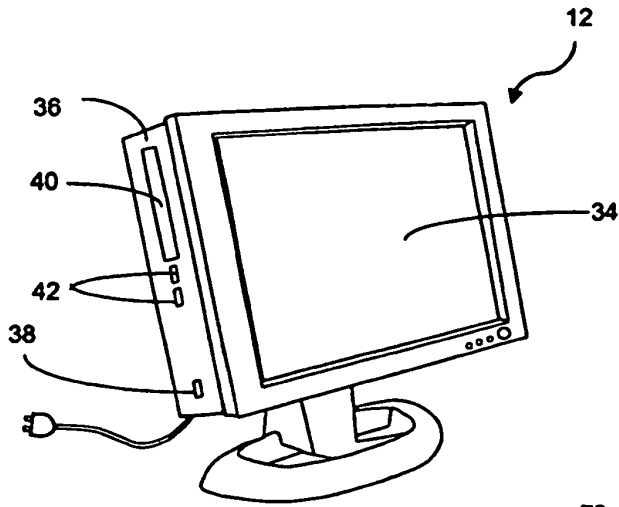

FIG. 6

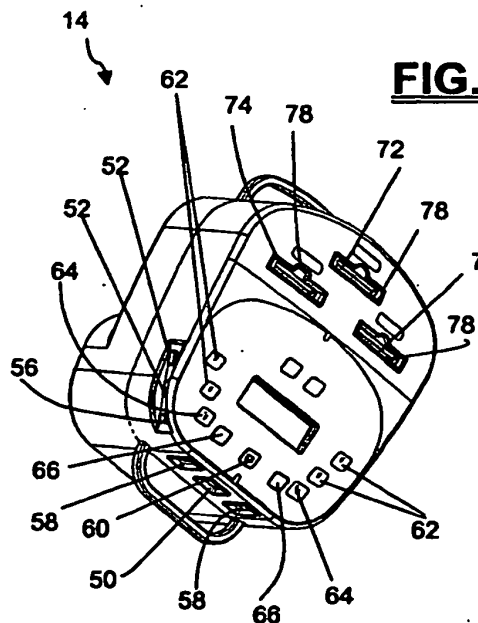

FIG. 7

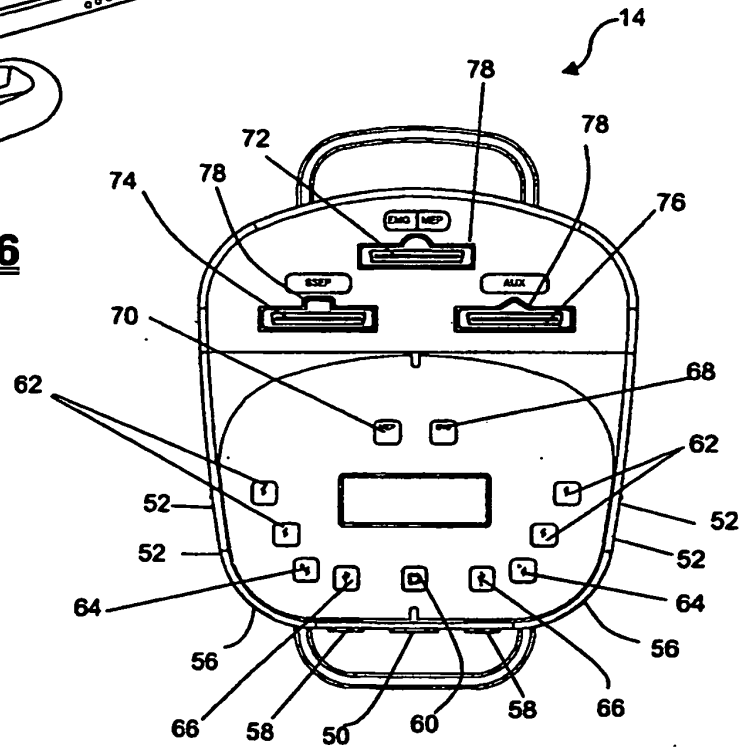

FIG. 8

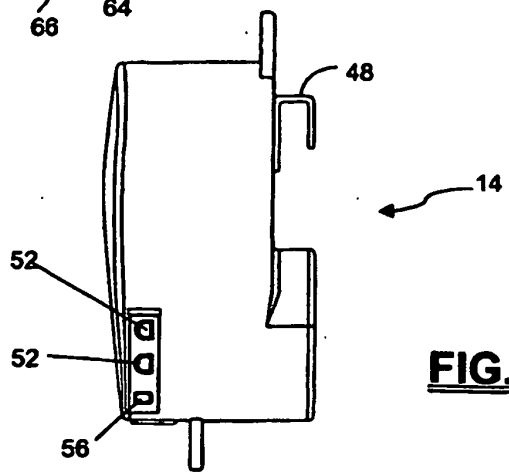

FIG. 9

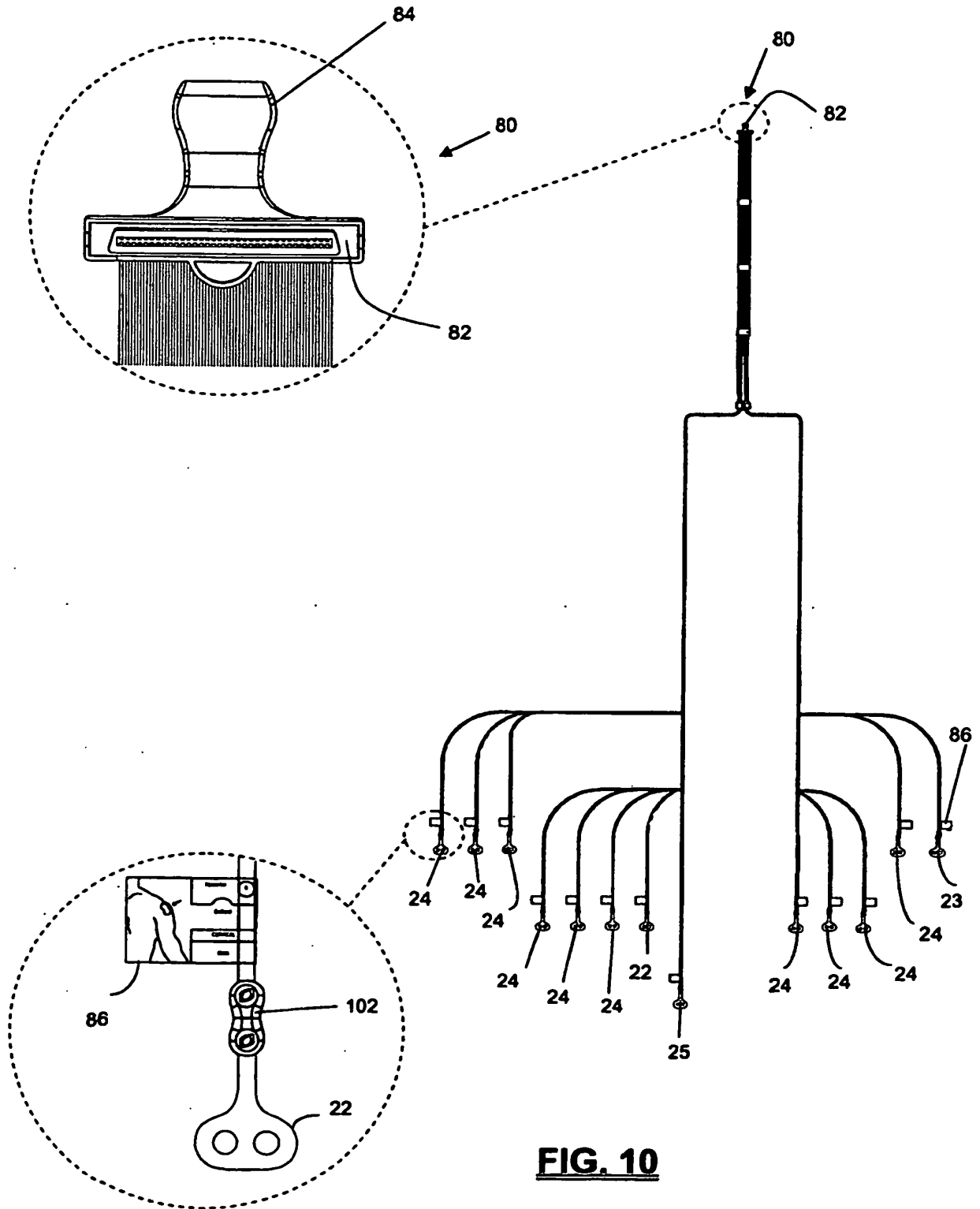

FIG. 10

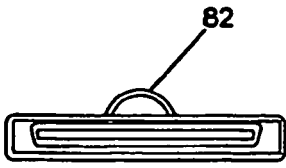

FIG. 11A

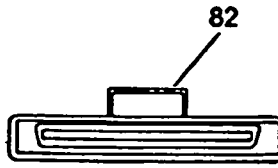

FIG. 11B

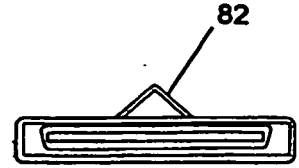

FIG. 11C

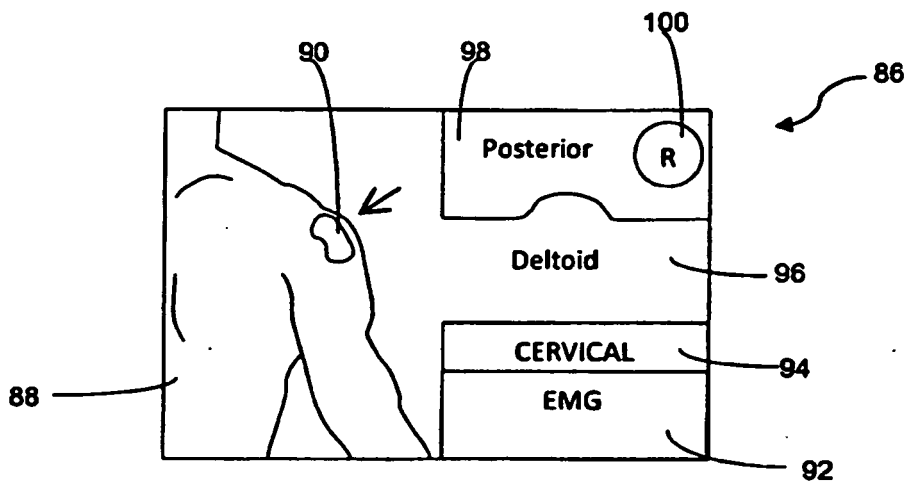

FIG. 12

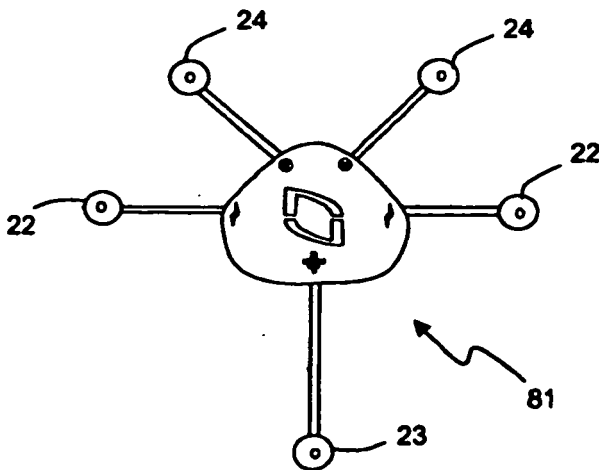

FIG. 13A

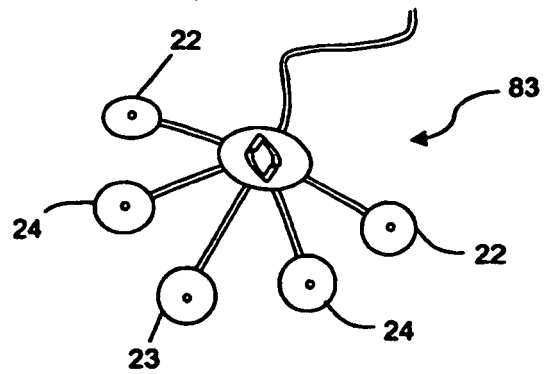

FIG. 13B

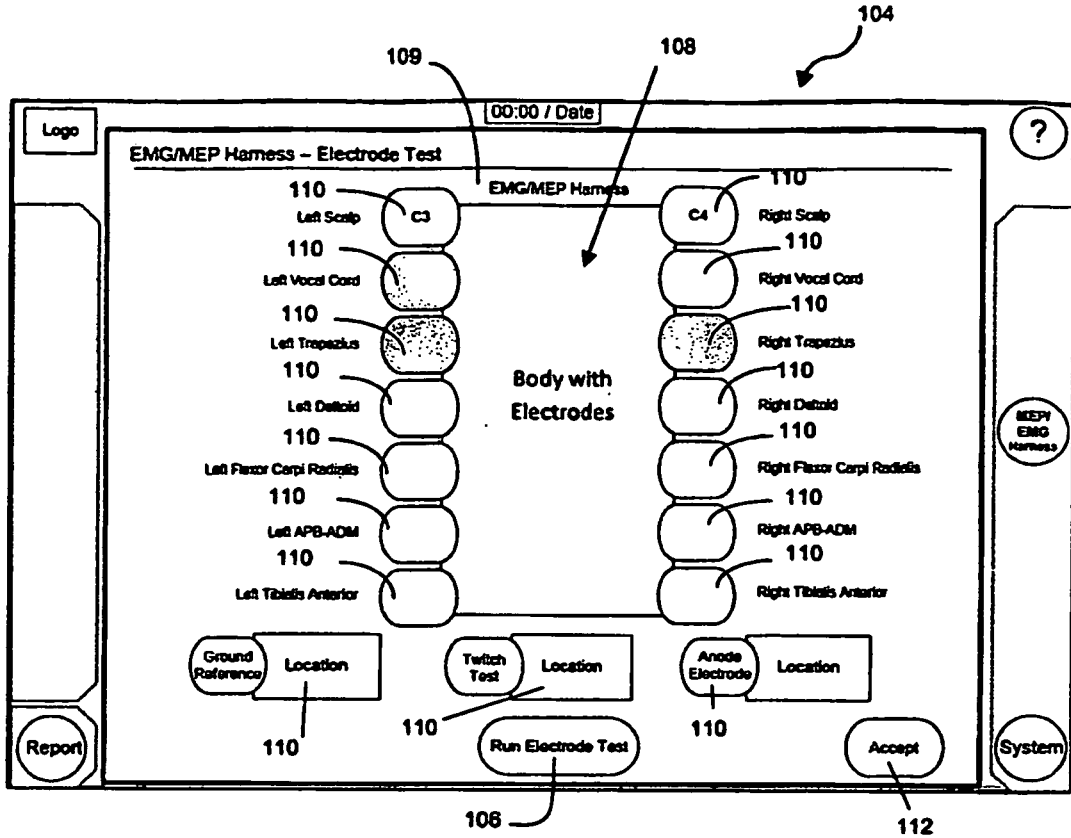

FIG. 14A

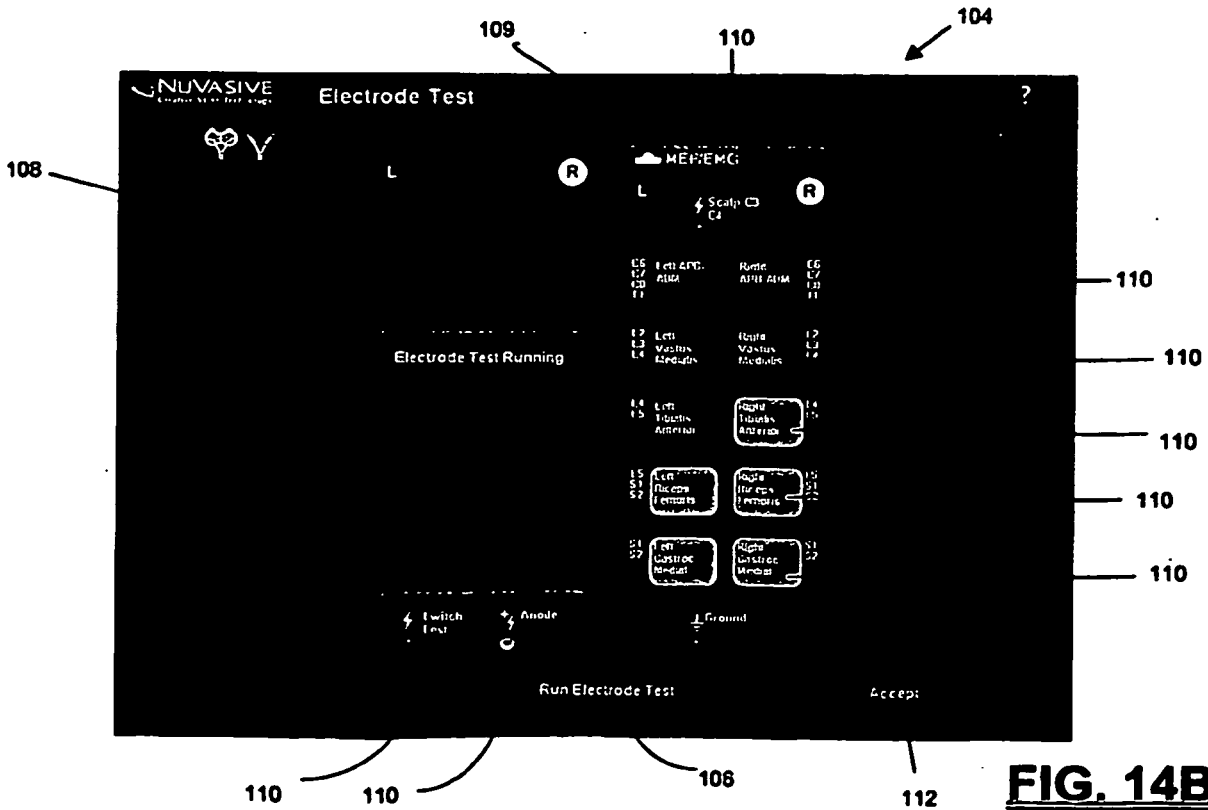
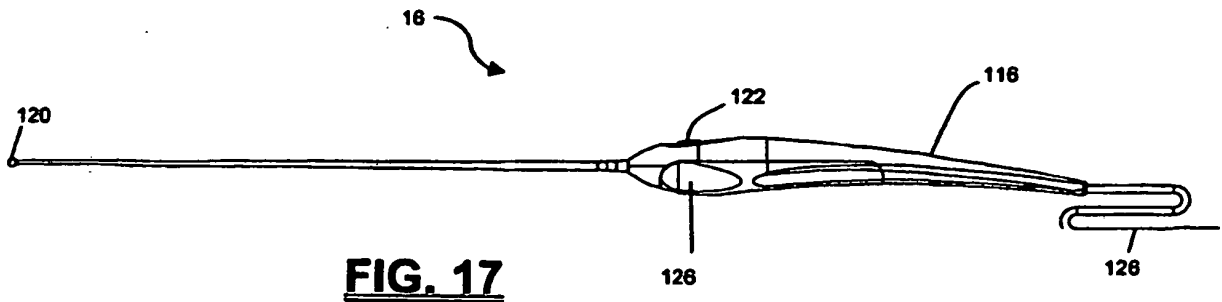
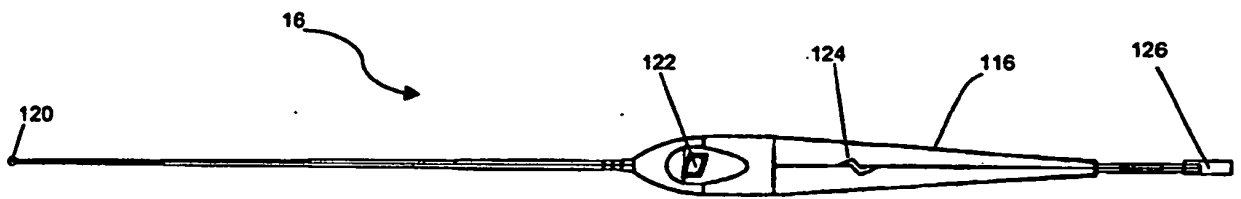
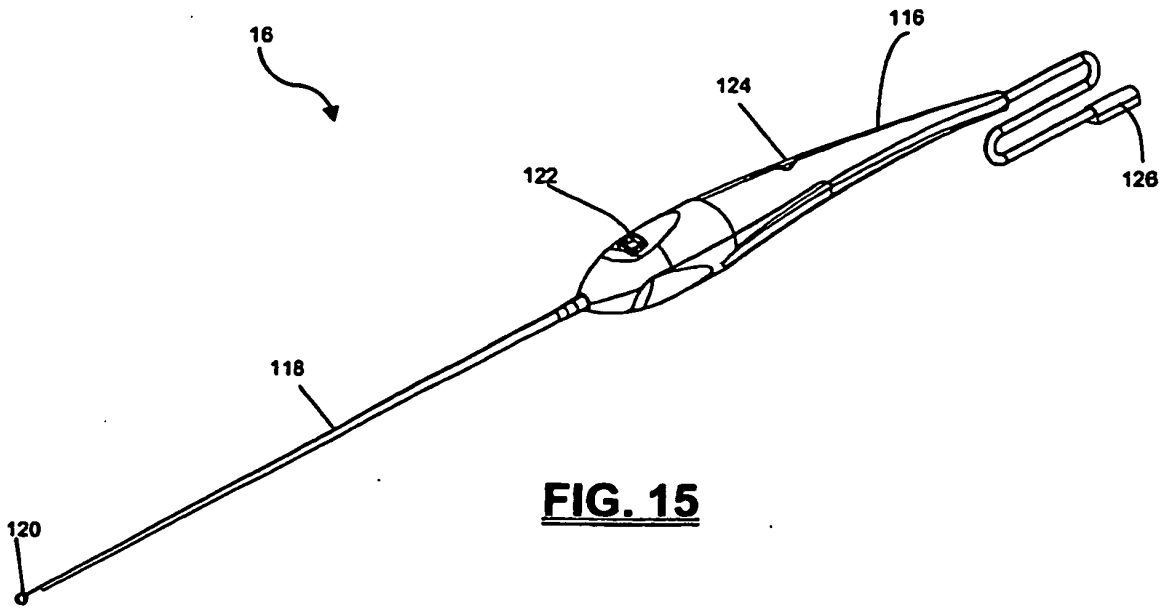

FIG. 14B



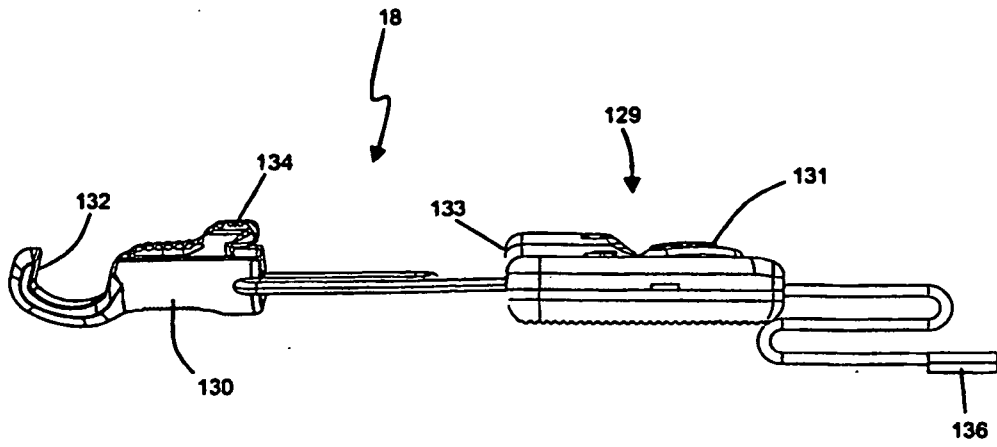

FIG. 18

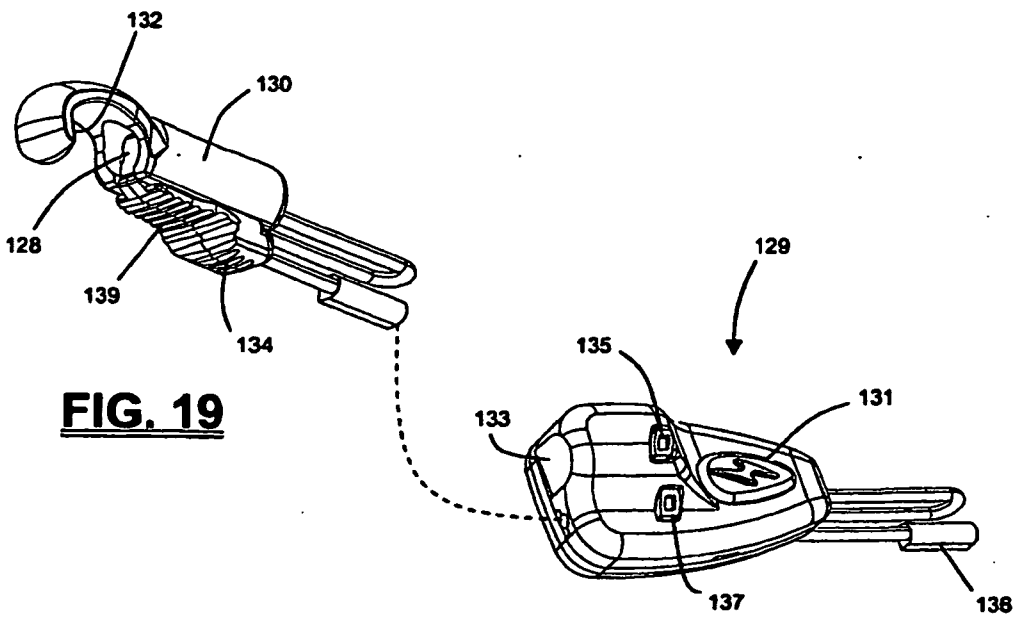

FIG. 19

FIG. 20

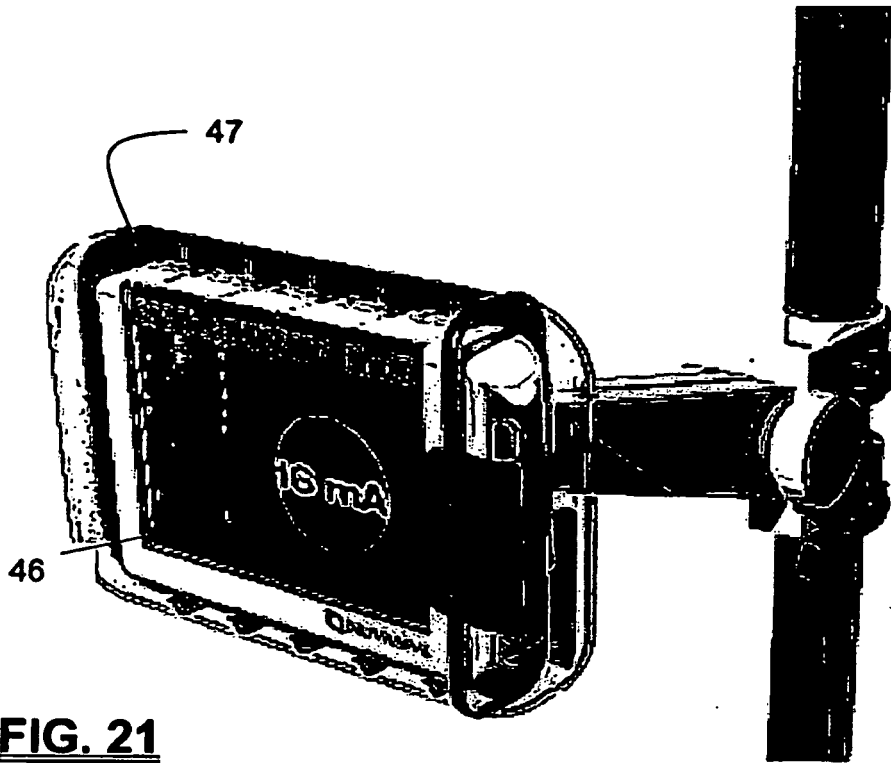

FIG. 21

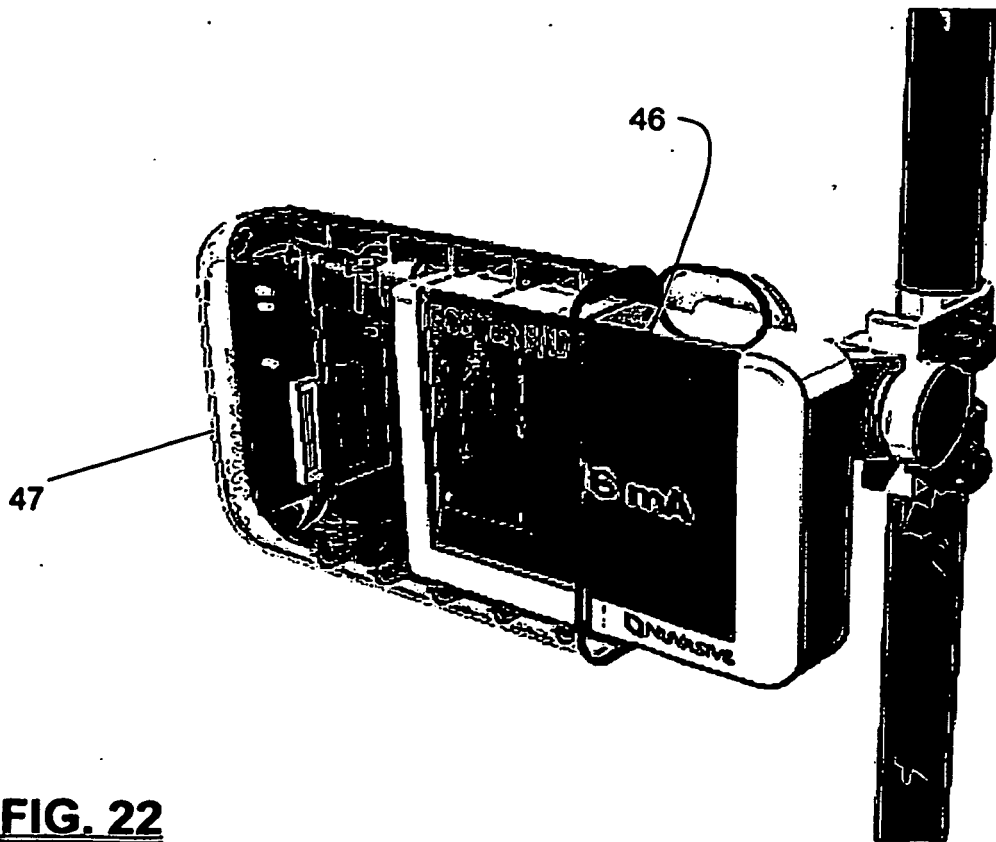

FIG. 22

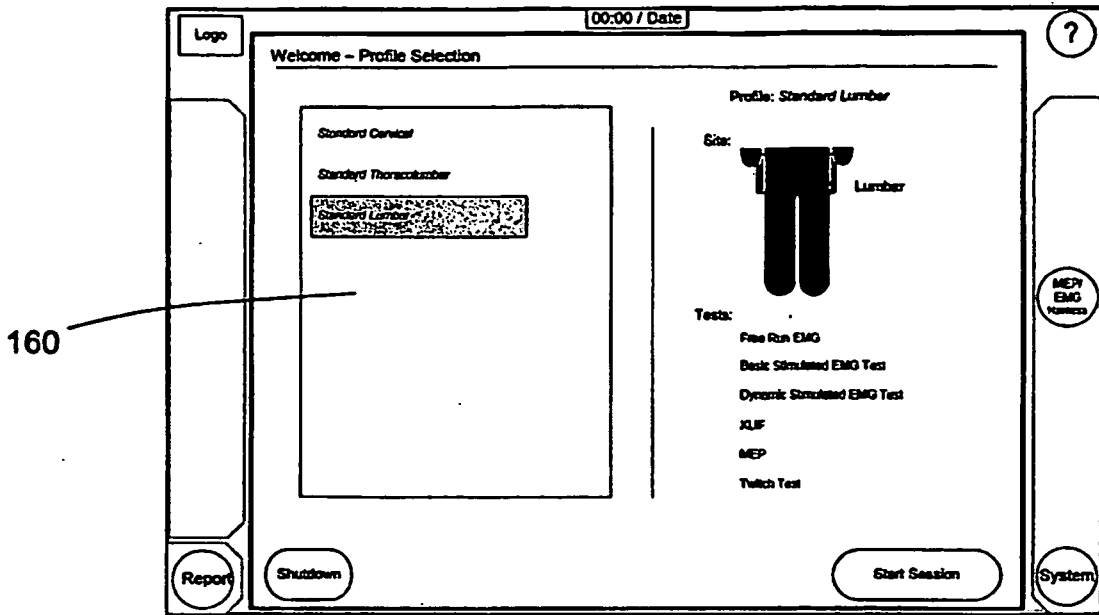

FIG. 23A

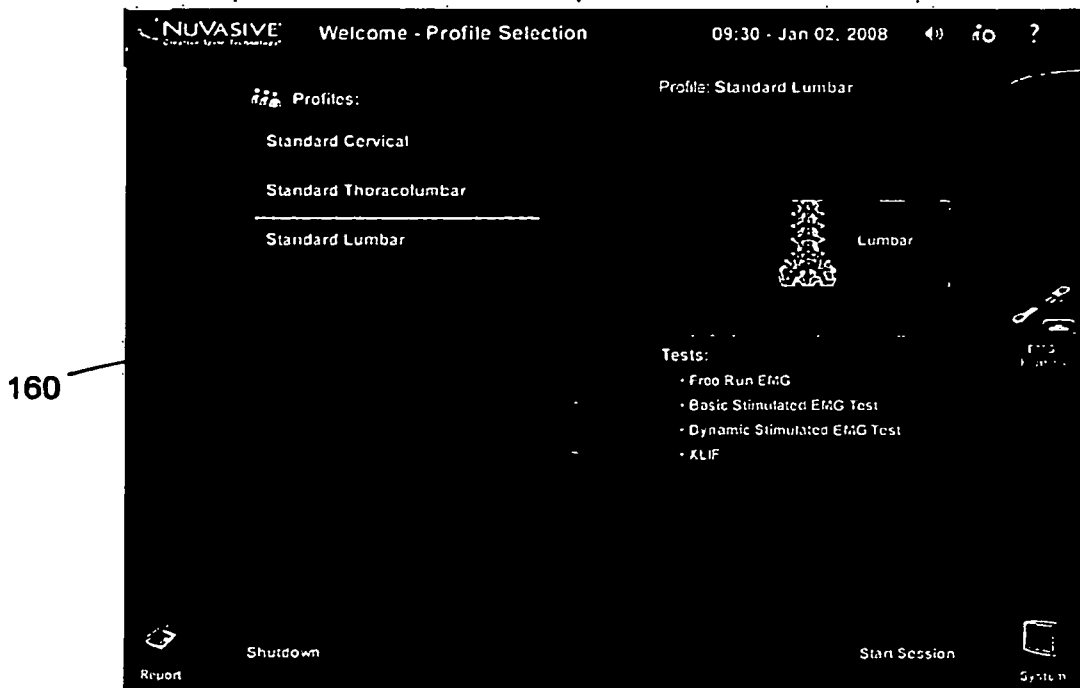

FIG. 23B

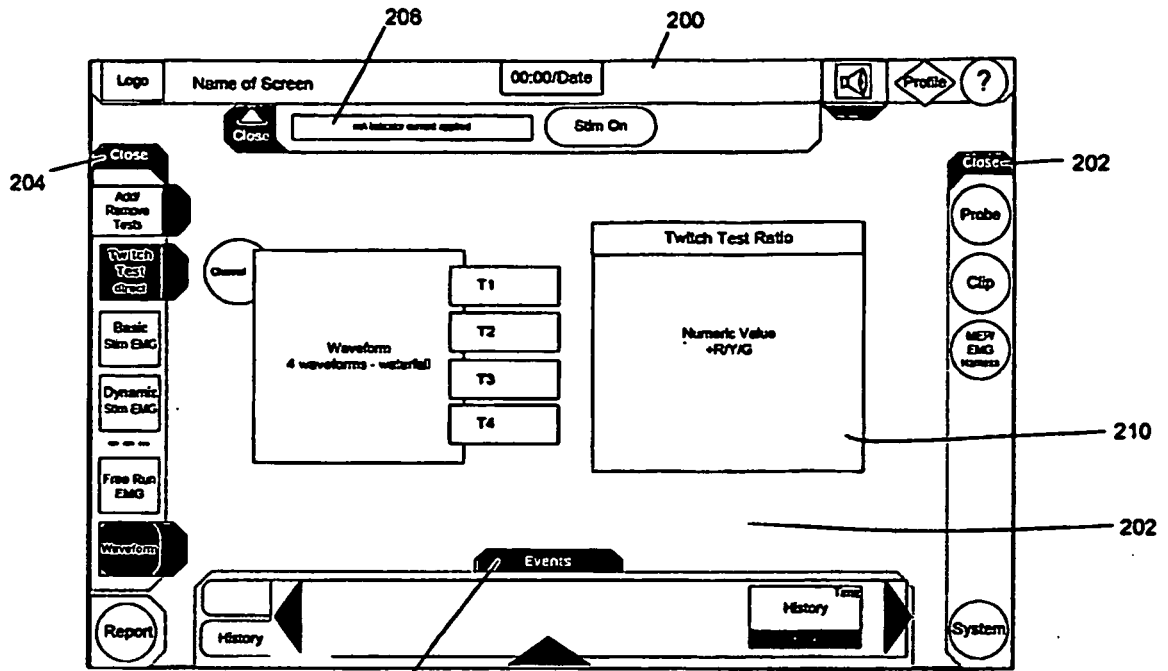

FIG. 24A

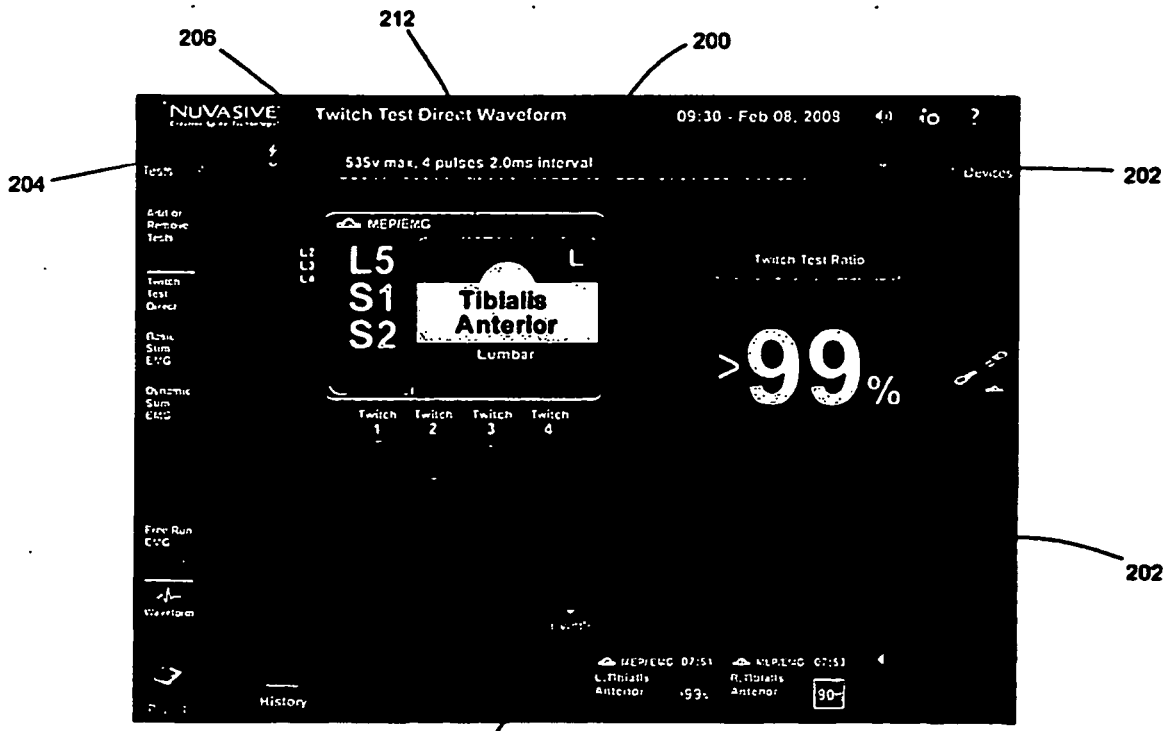

FIG. 24B

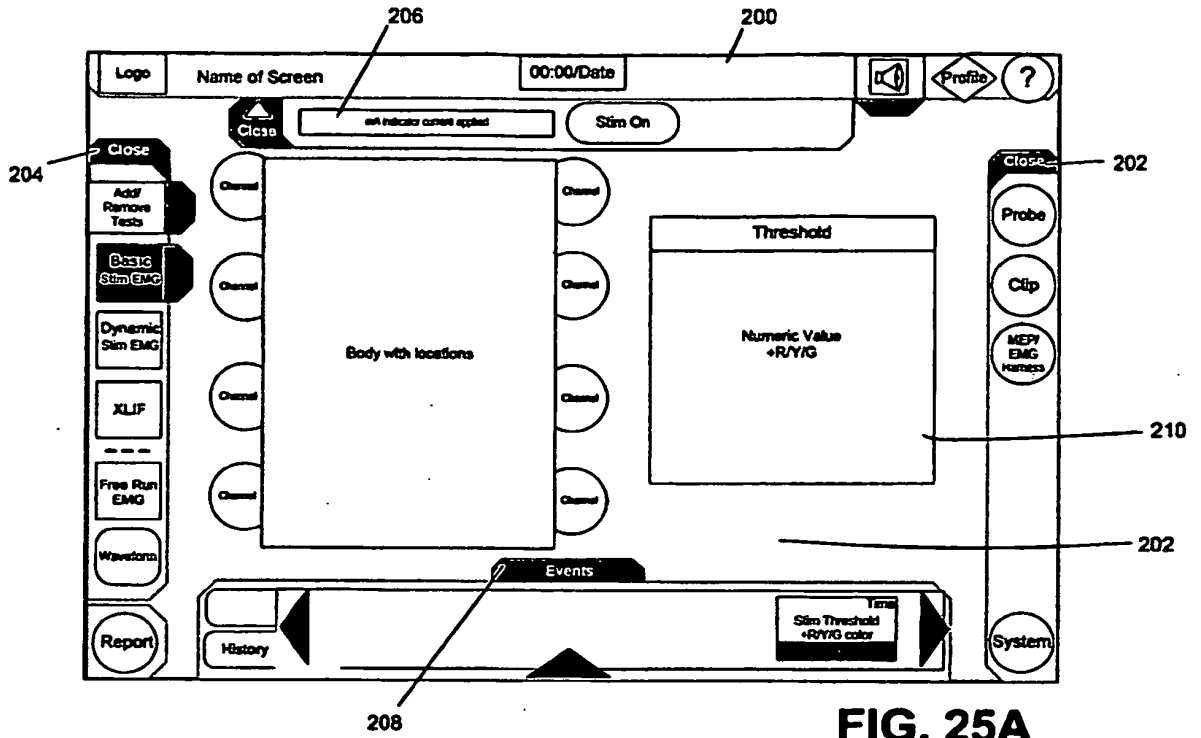

FIG. 25A

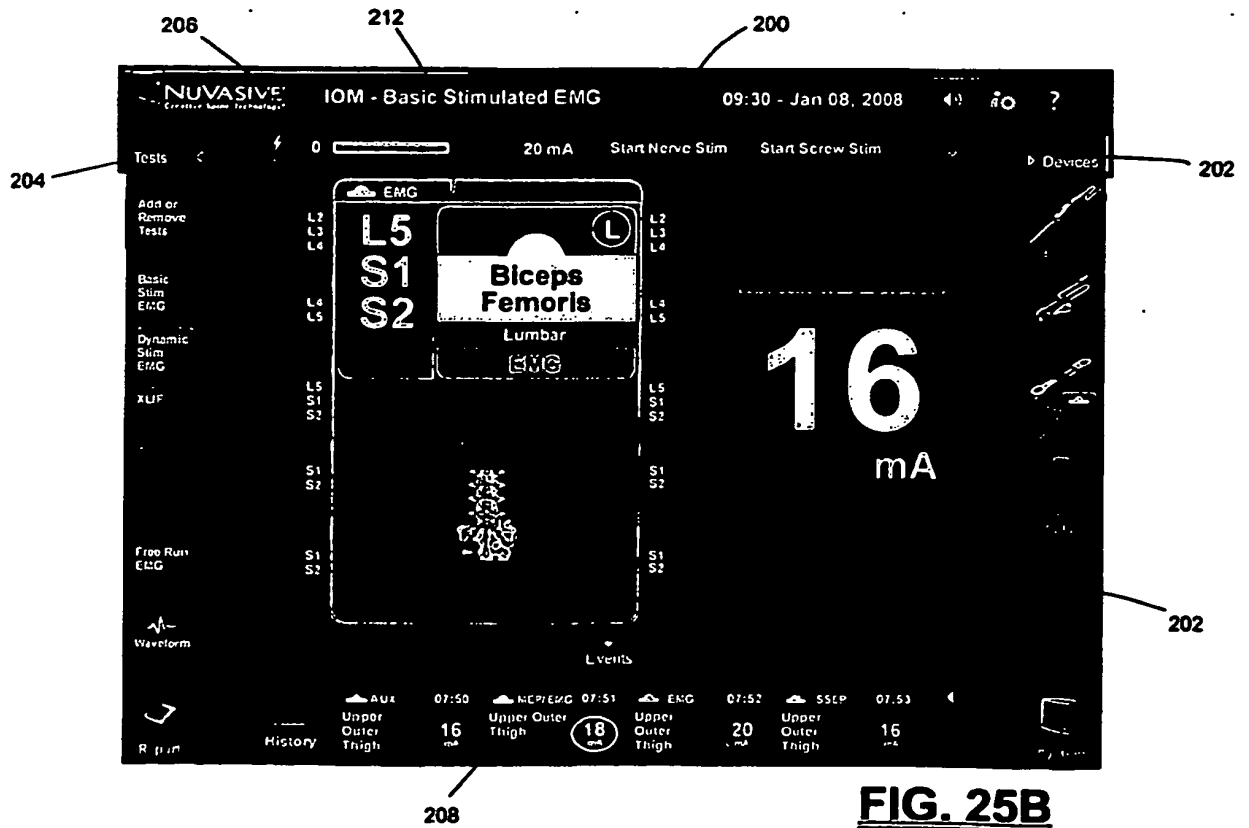

FIG. 25B

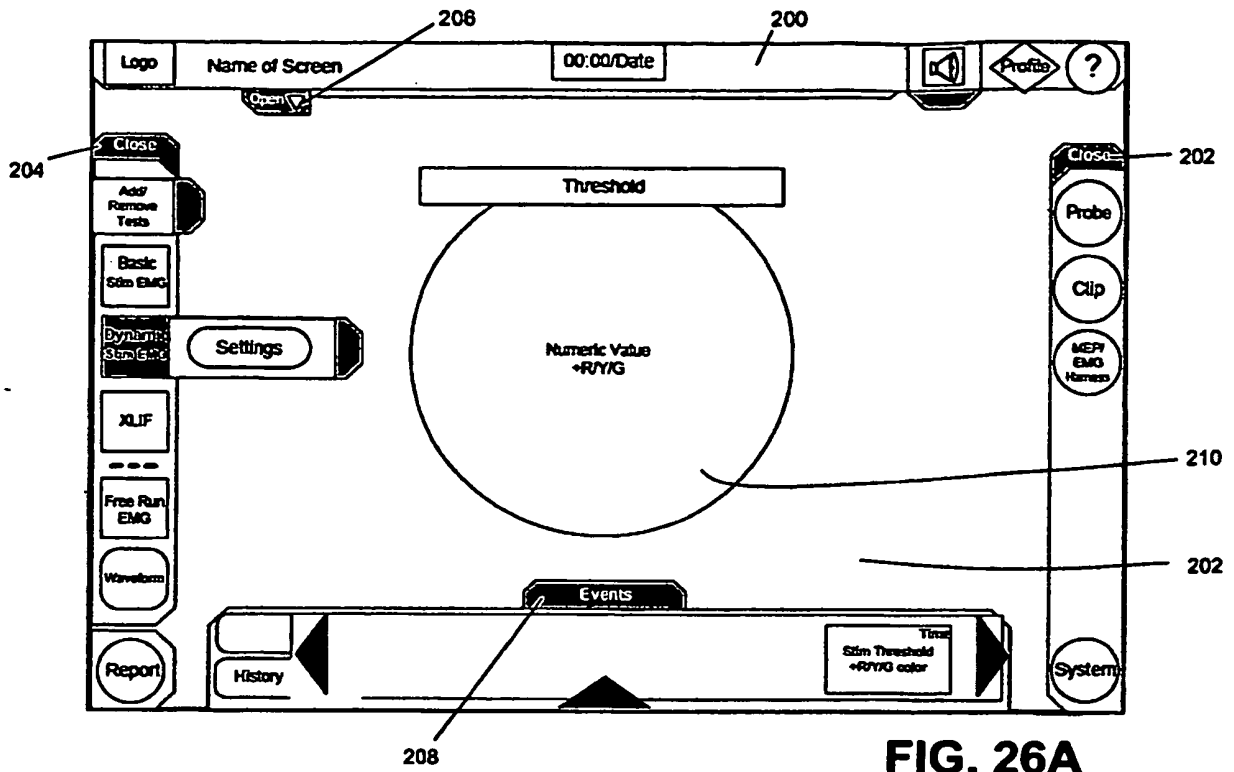

FIG. 26A

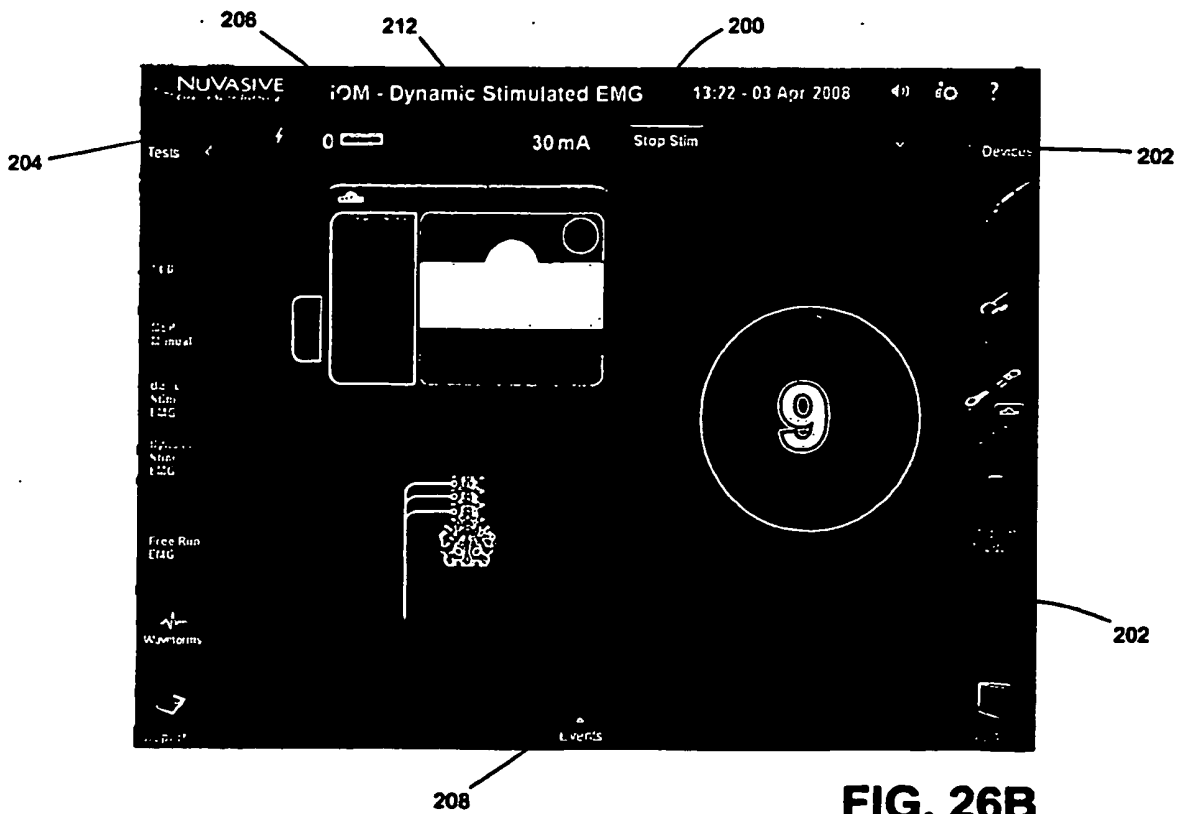

FIG. 26B

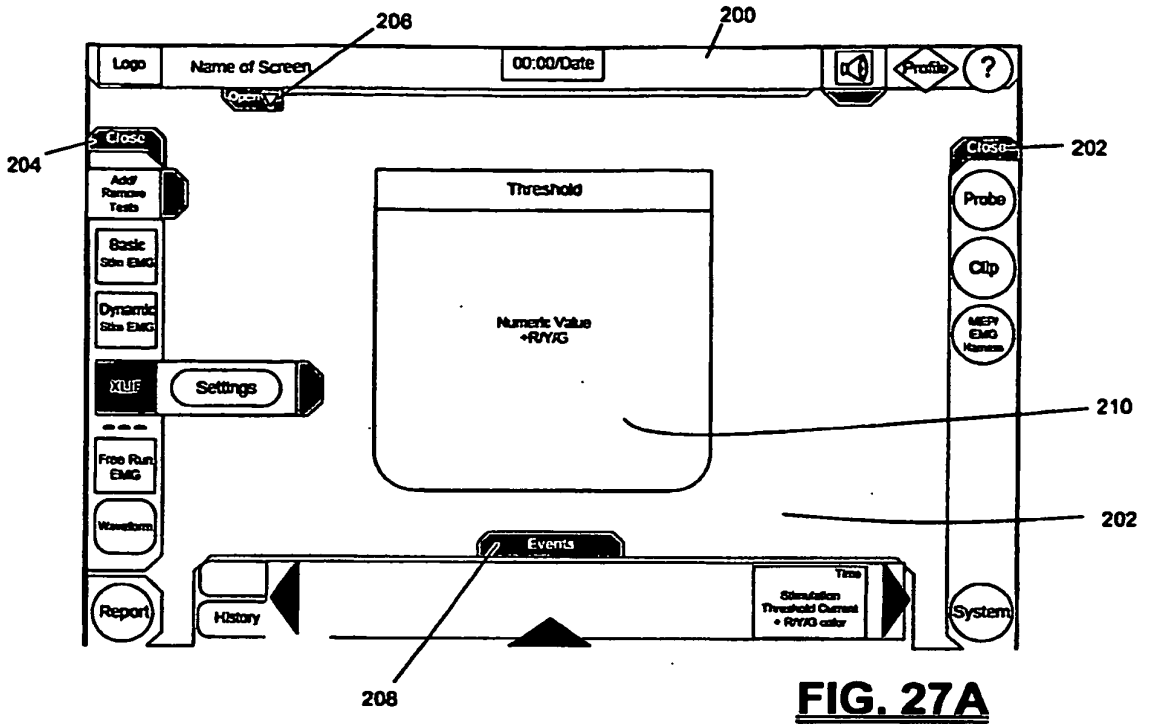

FIG. 27A

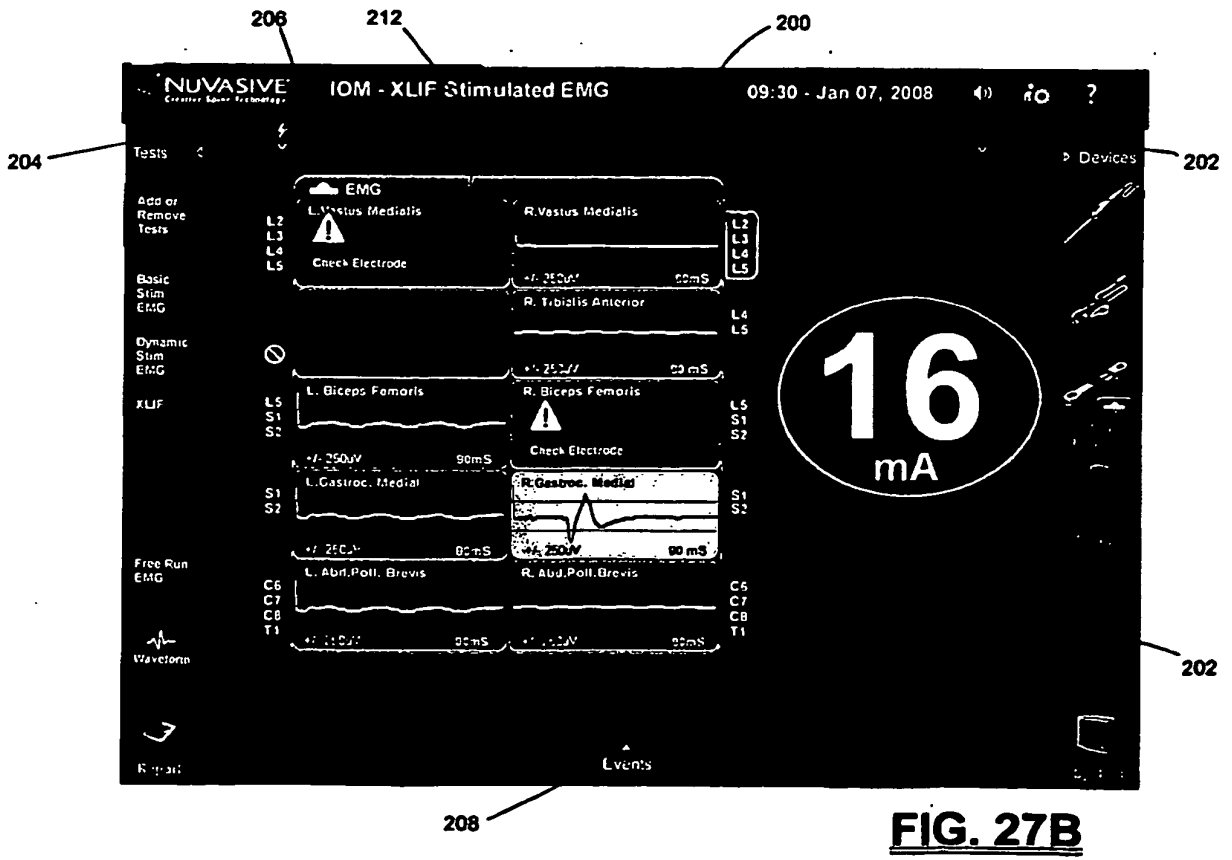

FIG. 27B

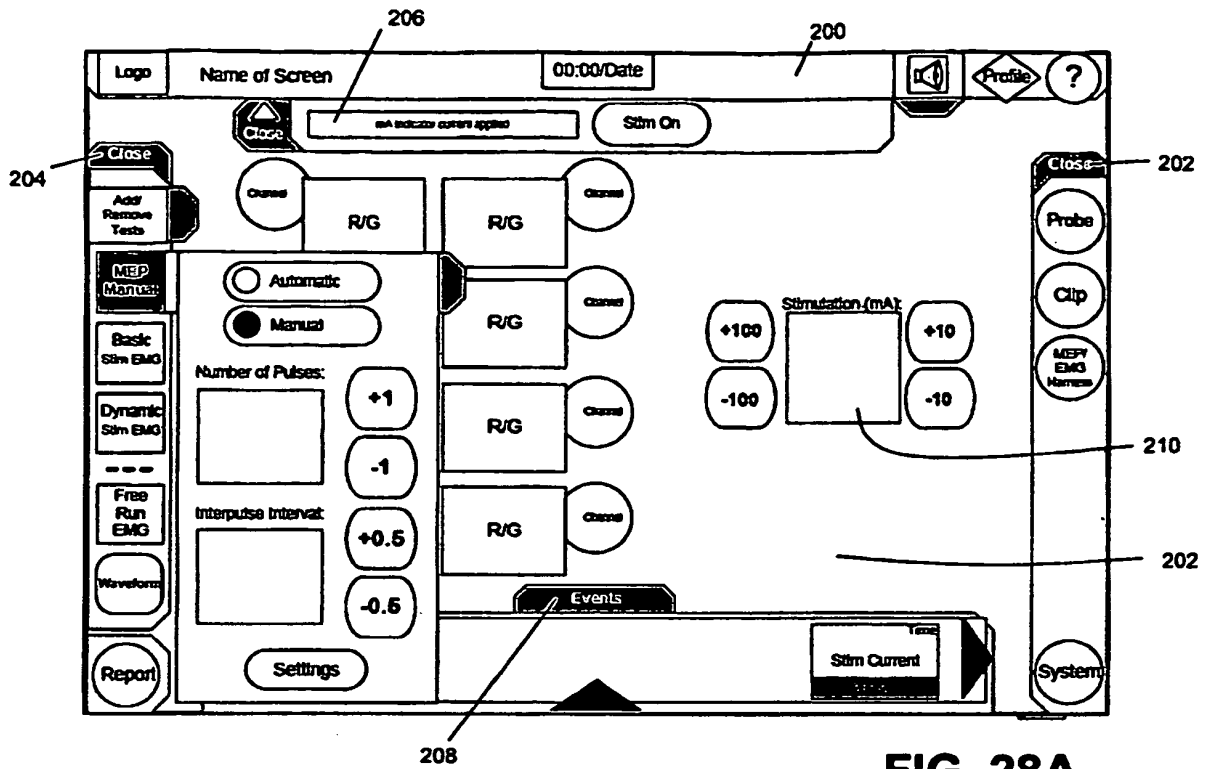

FIG. 28A

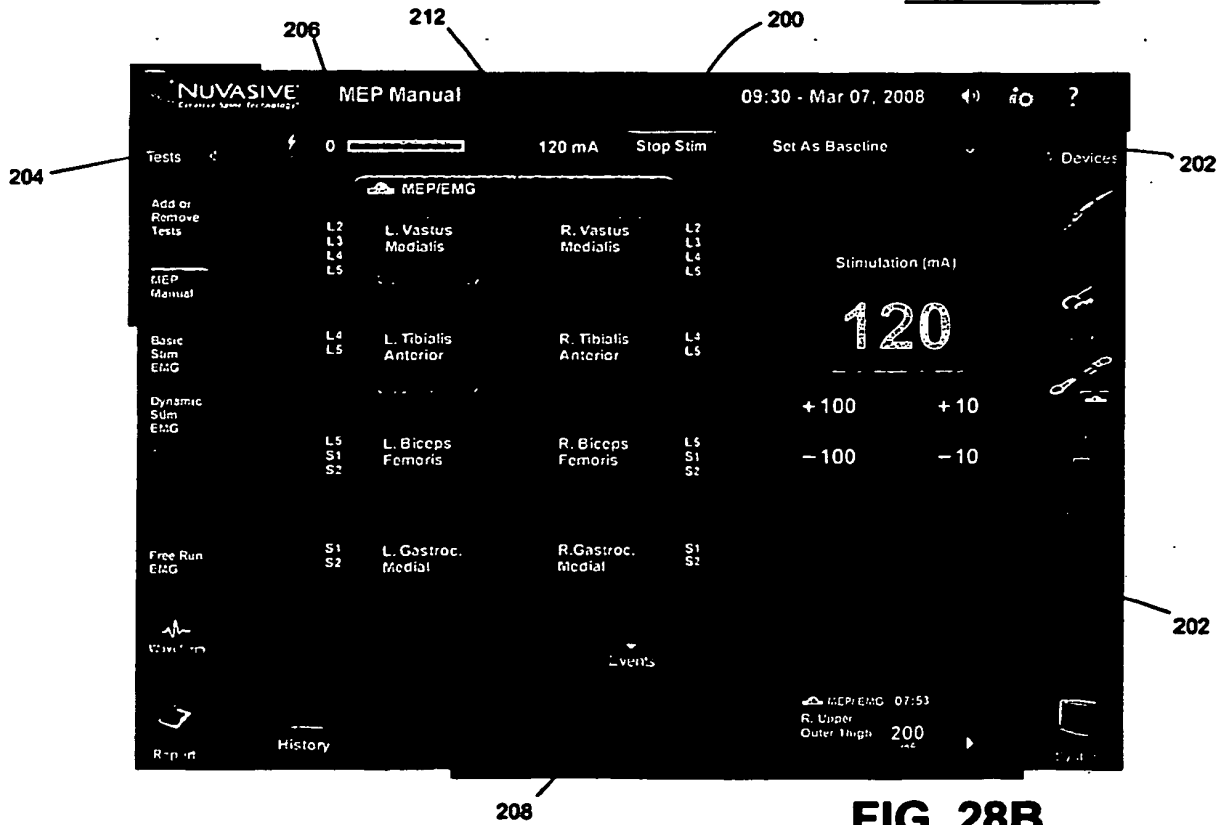

FIG. 28B

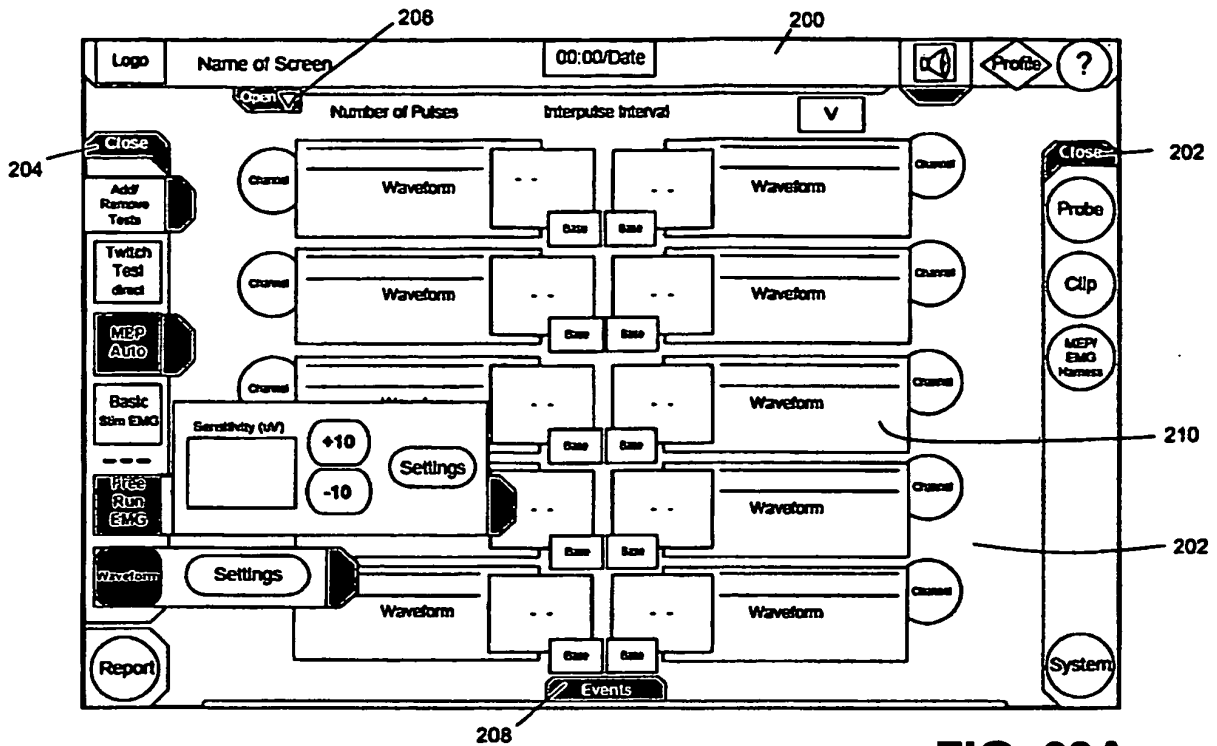

FIG. 29A

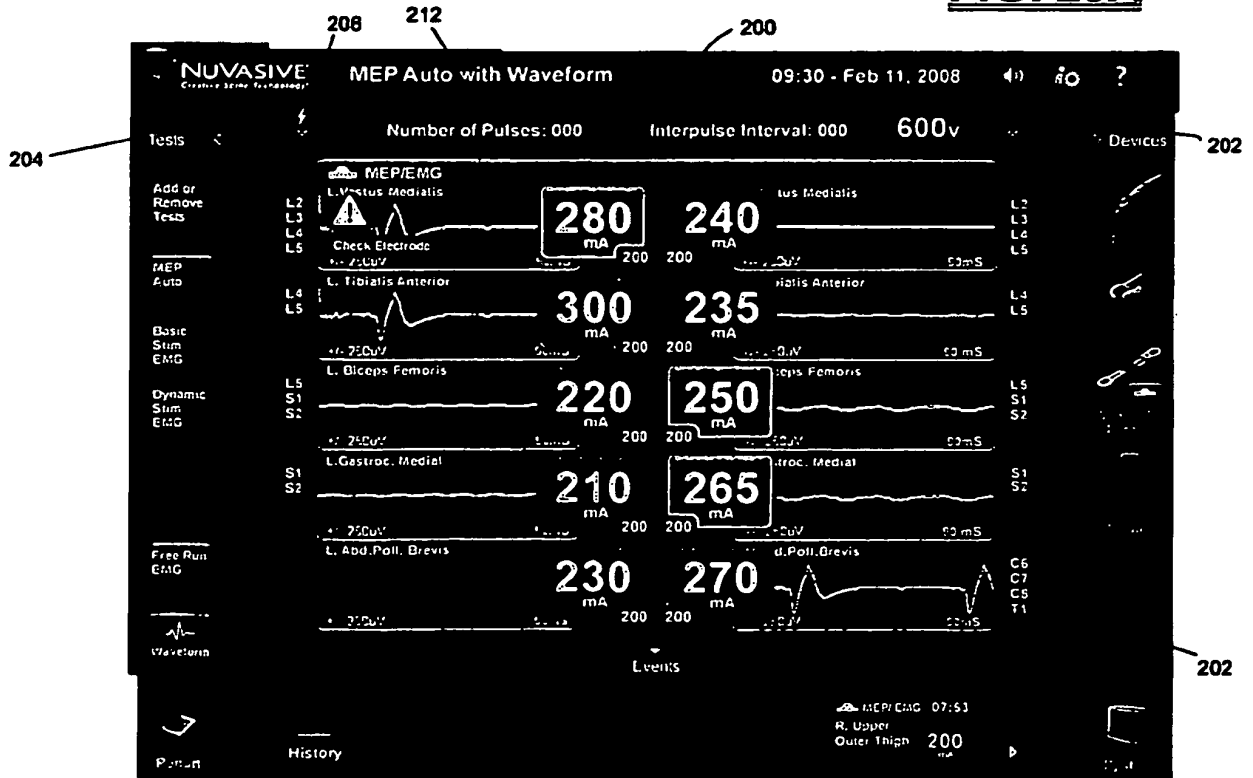

FIG. 29B

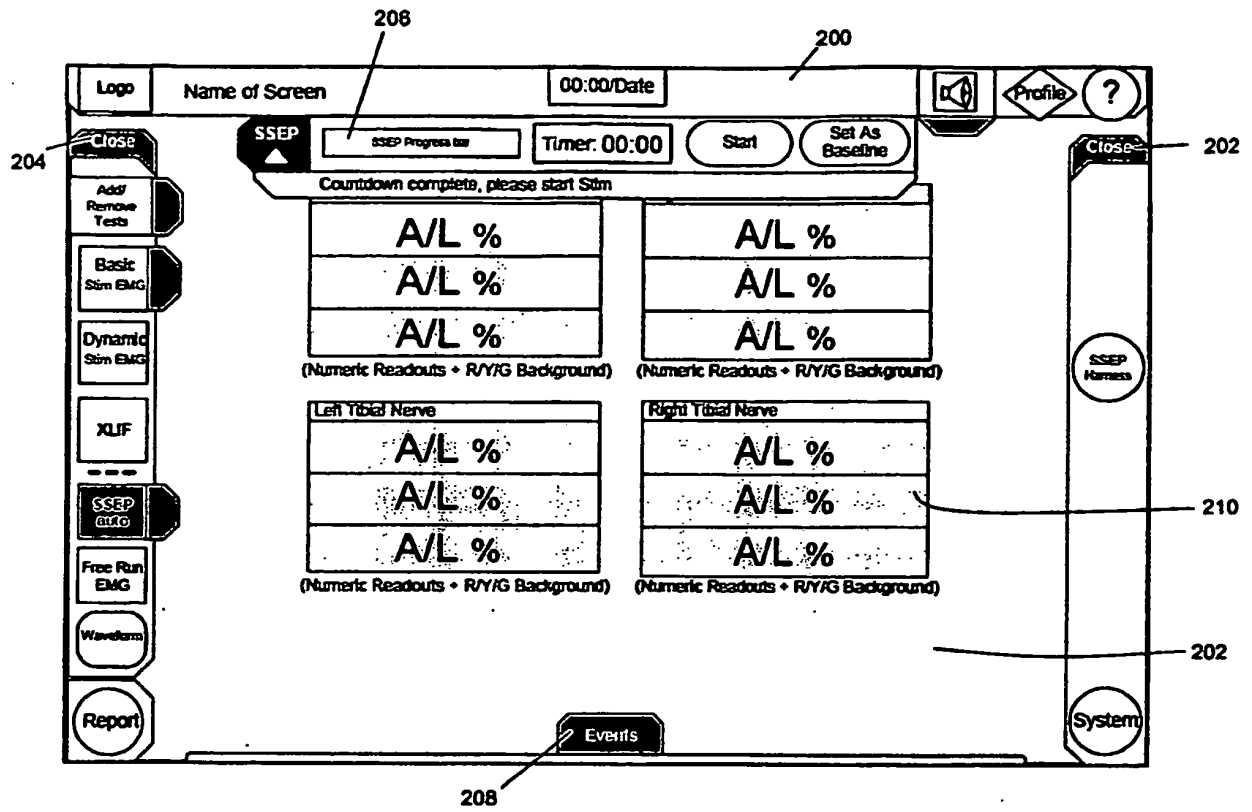

FIG. 30

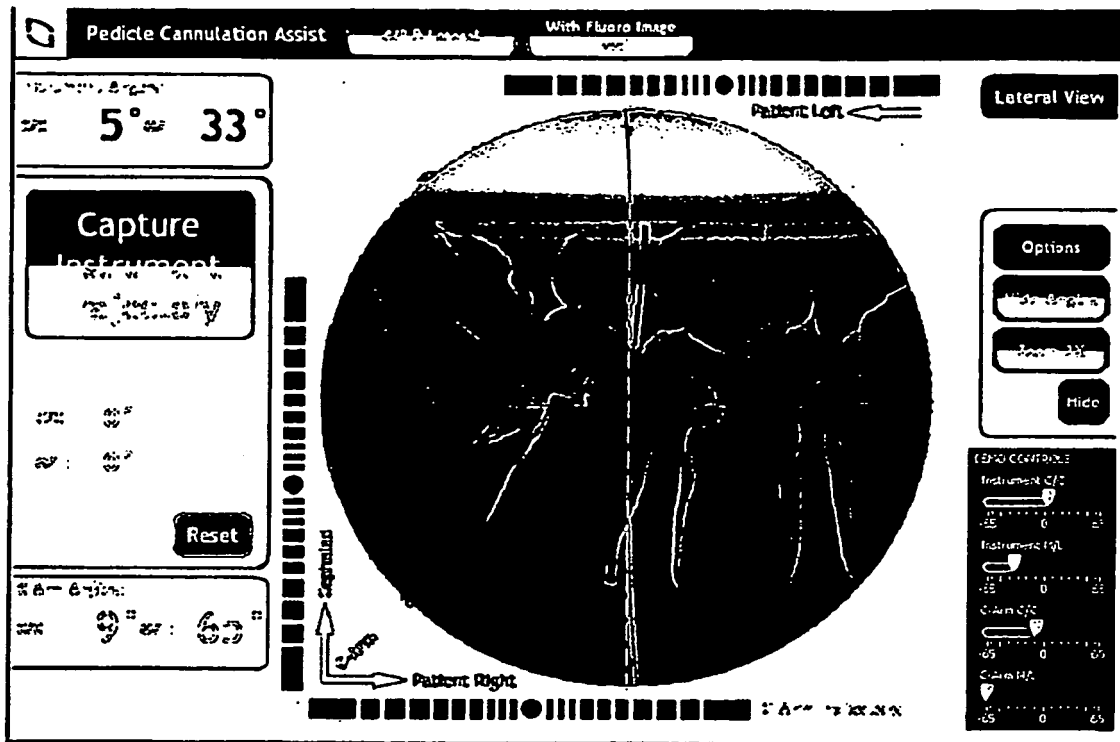

FIG. 31

FIG. 32A

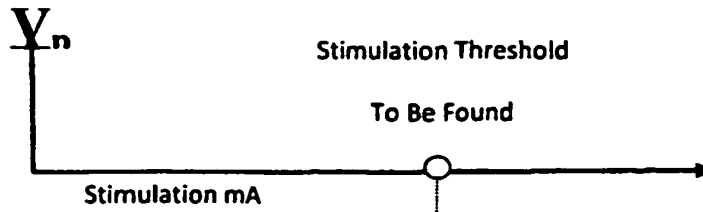

FIG. 32B

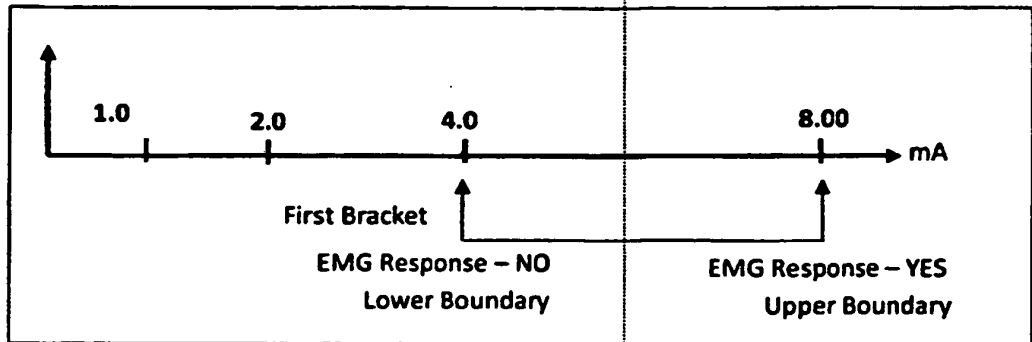

FIG. 32C

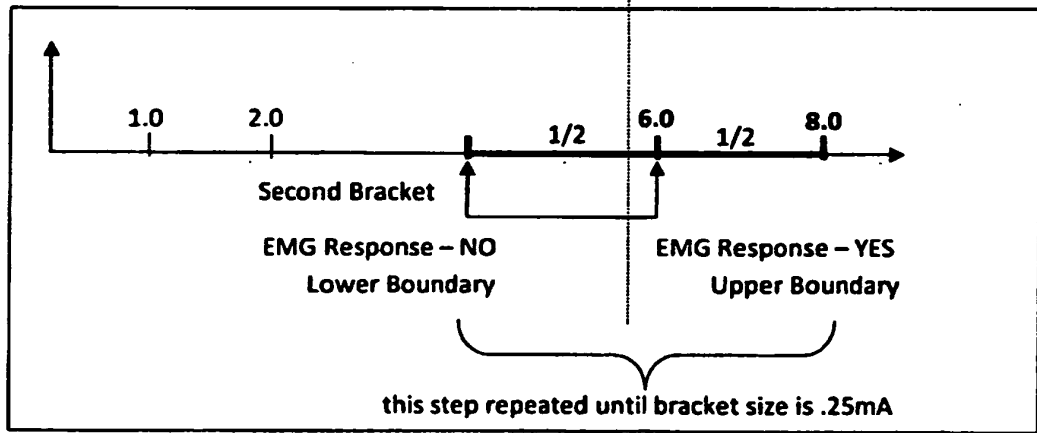
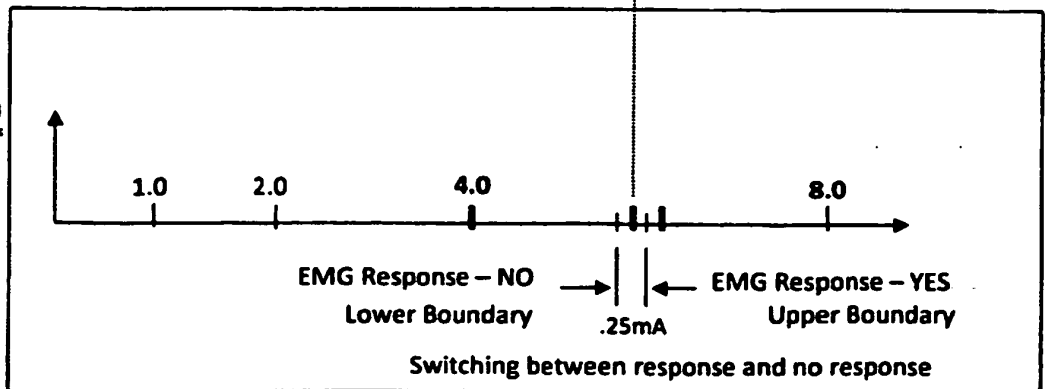

FIG. 32D



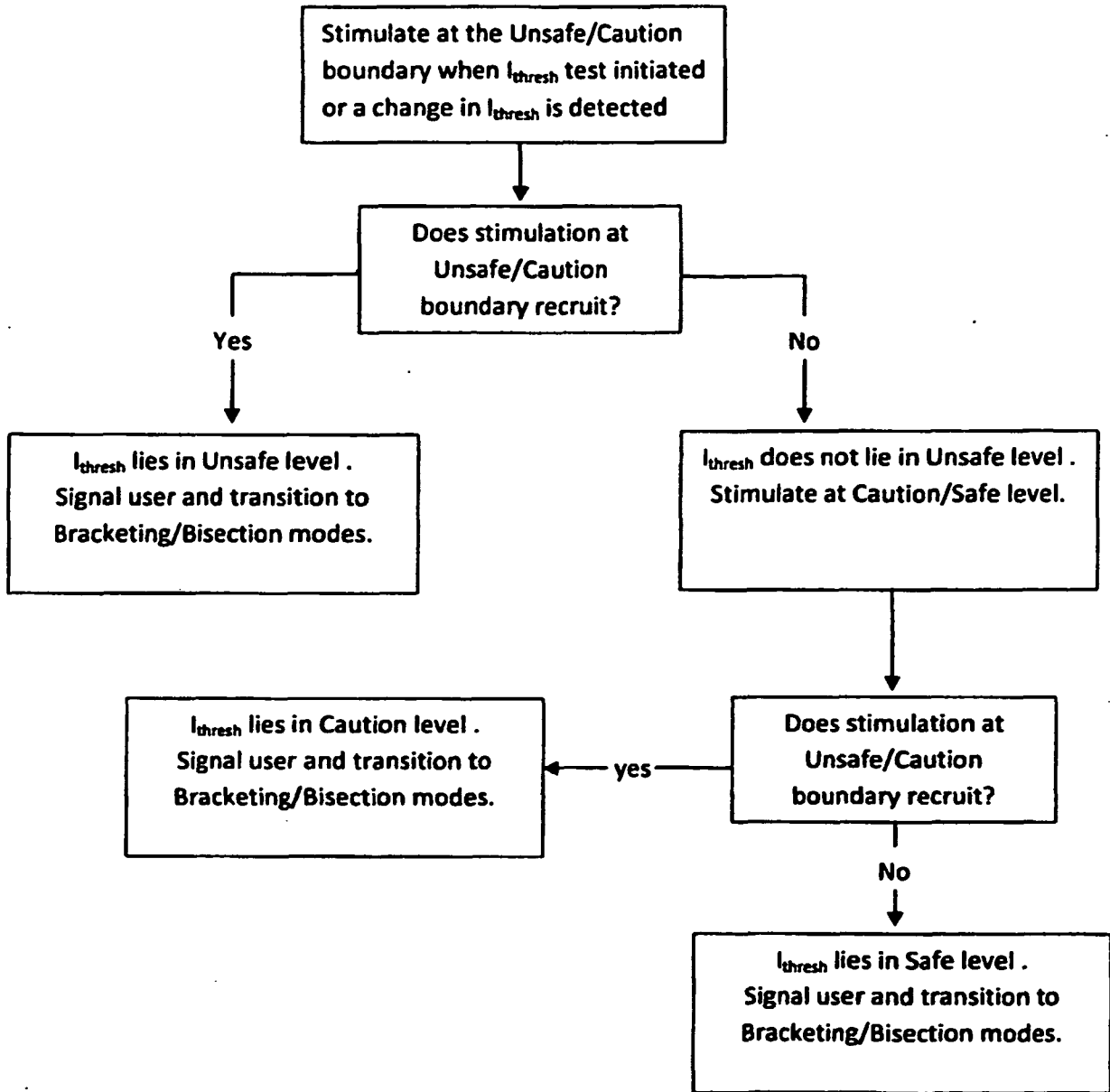
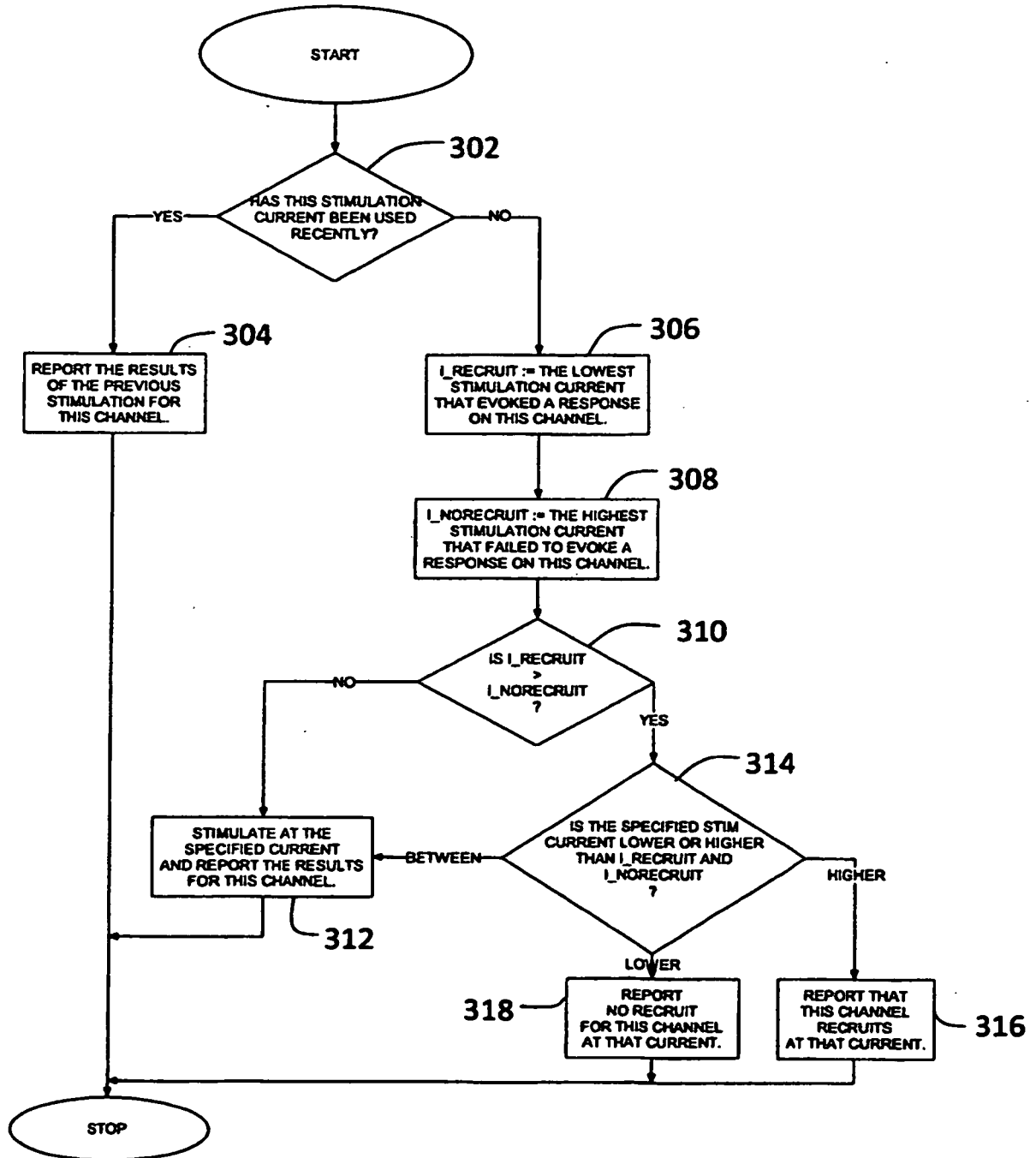
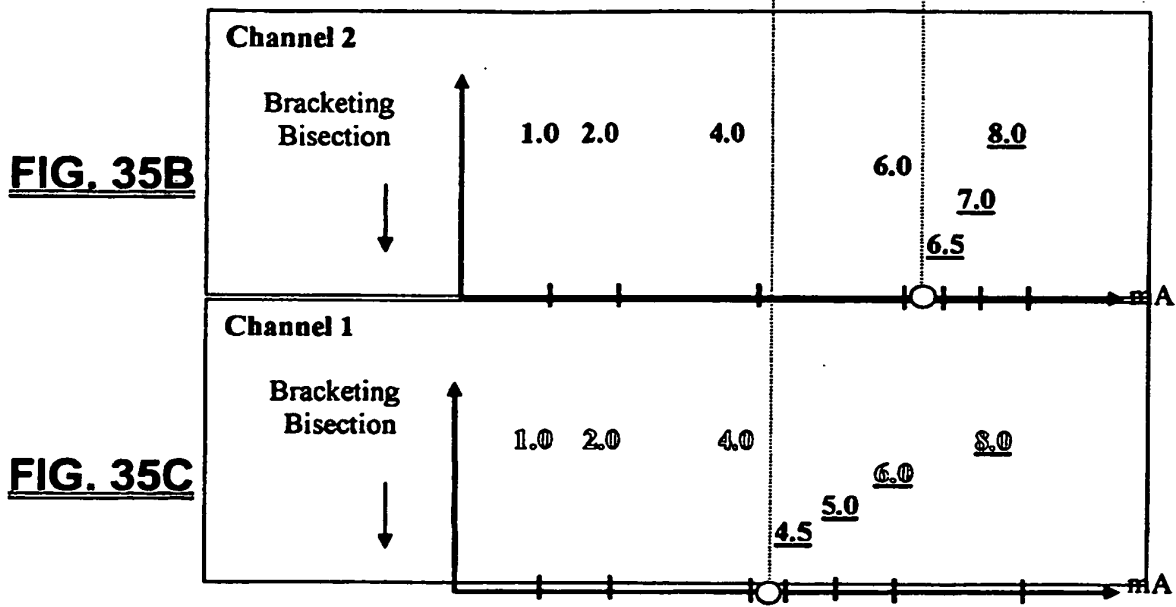
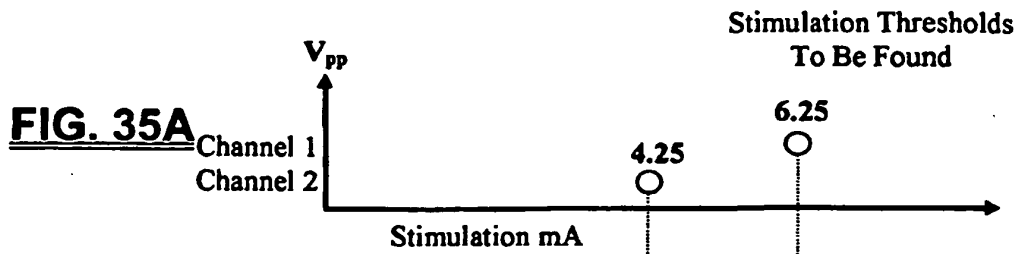

FIG. 33





LEGEND	
#	= actual recruit
#	= inferred recruit
#	= actual nonrecruit
#	= inferred nonrecruit

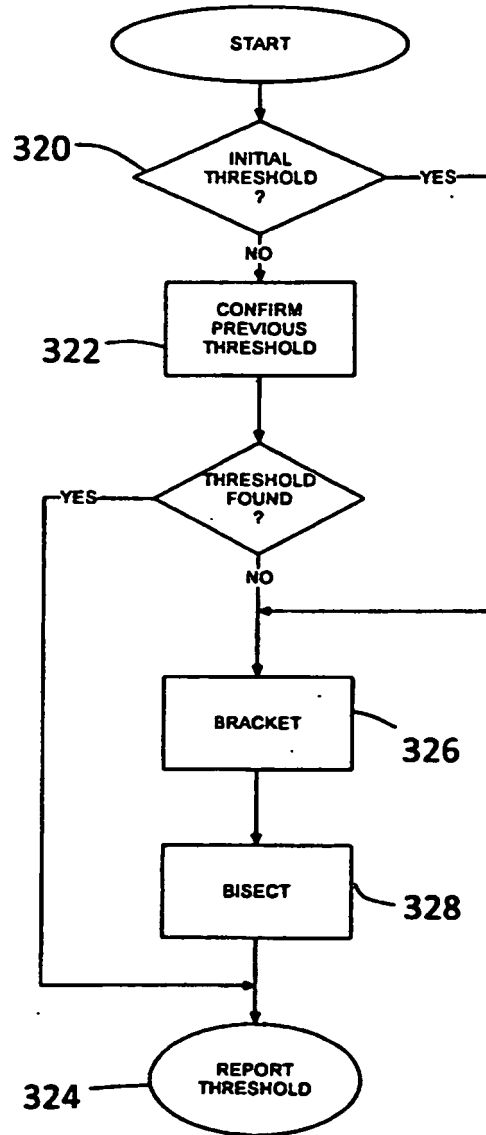

FIG. 36A

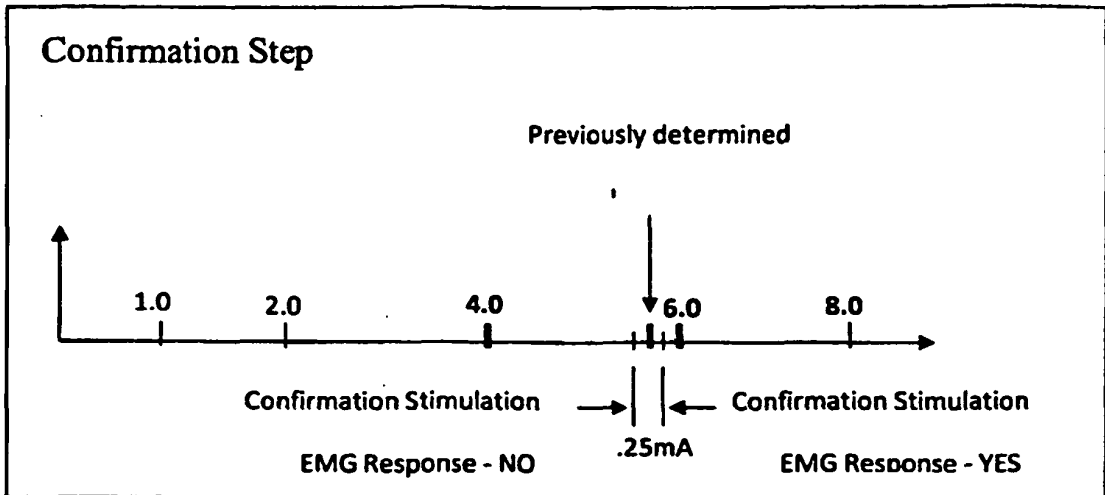

FIG. 36B

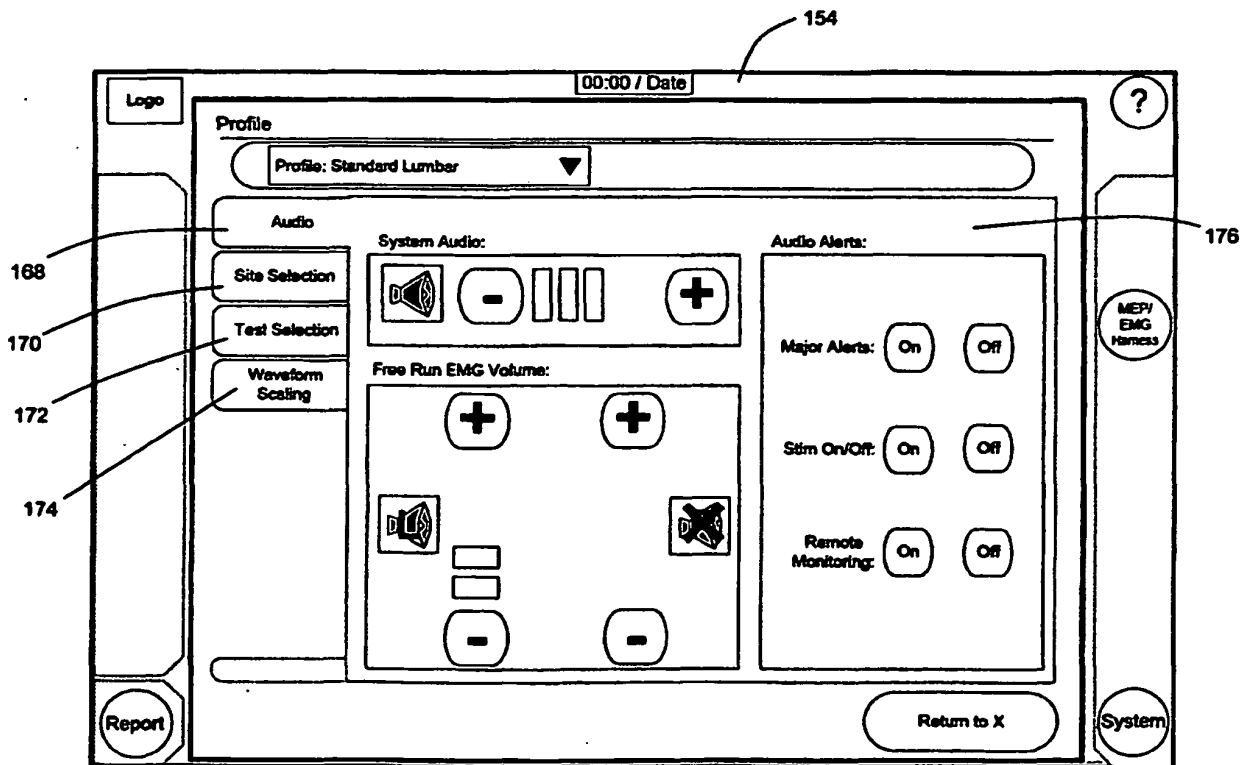

FIG. 37

REFERENCES CITED IN THE DESCRIPTION

This list of references cited by the applicant is for the reader's convenience only. It does not form part of the European patent document. Even though great care has been taken in compiling the references, errors or omissions cannot be excluded and the EPO disclaims all liability in this regard.

Patent documents cited in the description

- US 20050004623 A [0005]
- US 5947964 A [0005]
- US 2005036089 W [0032]
- US 0235047 W [0032]
- US 2004025550 W [0032]
- US 200222247 W [0032]
- US 200230617 W [0032]
- US 2006003966 W [0032]
- US 200711962 W [0032]
- US 20040255500 W [0044]

专利名称(译)	神经生理学监测系统		
公开(公告)号	EP2142087A4	公开(公告)日	2010-06-16
申请号	EP2008742578	申请日	2008-04-03
[标]申请(专利权)人(译)	NUVASIVE		
申请(专利权)人(译)	NUVASIVE INC.		
当前申请(专利权)人(译)	NUVASIVE INC.		
[标]发明人	GHARIB JAMES FARQUHAR ALLEN LAYMAN DOUG SCHOLL THOMAS POTHIER ALBERT MARTINELLI SCOT IVANKO DAVE FERNANDES ANTONIO		
发明人	GHARIB, JAMES FARQUHAR, ALLEN LAYMAN, DOUG SCHOLL, THOMAS POTHIER, ALBERT MARTINELLI, SCOT IVANKO, DAVE FERNANDES, ANTONIO		
IPC分类号	A61B5/05 A61B5/04 A61B5/00 A61B5/0488 A61B5/0492 A61B17/00 A61B17/16 A61B17/17 A61N1/05 A61N1/08 A61N1/36		
CPC分类号	A61B5/04001 A61B5/0488 A61B5/0492 A61B5/05 A61B5/407 A61B5/4893 A61B17/1626 A61B17/ /1671 A61B17/1757 A61B2017/00022 A61B2017/00026 A61N1/0551 A61B5/4566 A61B5/7271 A61B5/ /7405 A61B5/742 A61B5/7455 A61B5/746 A61B17/00 A61B34/20 A61N1/08 A61N1/36014		
优先权	60/921718 2007-04-03 US 61/000354 2007-10-24 US		
其他公开文献	EP2142087A1 EP2142087B1		
外部链接	Espacenet		

摘要(译)

本发明涉及一般旨在手术的系统和方法。更具体地，本发明涉及用于执行涉及使用神经生理学的外科手术和评估的系统和相关方法。

