



(12) **EUROPEAN PATENT APPLICATION**

(43) Date of publication:
22.12.2004 Bulletin 2004/52

(51) Int Cl.⁷: **A61B 5/00**

(21) Application number: **03101769.2**

(22) Date of filing: **17.06.2003**

(84) Designated Contracting States:
**AT BE BG CH CY CZ DE DK EE ES FI FR GB GR
HU IE IT LI LU MC NL PT RO SE SI SK TR**
Designated Extension States:
AL LT LV MK

(72) Inventor: **Moser, Raymond**
1024 Ecublens (CH)

(74) Representative: **P&TS**
Patents & Technology Surveys SA
Terreaux 7
P.O.Box 2848
2001 Neuchâtel (CH)

(71) Applicant: **Moser, Raymond**
1024 Ecublens (CH)

(54) **Instrumented retrievable implantable device**

(57) Instrumented retrievable implantable device (2), comprising an expandable section, for placement inside a body lumen, preferably in a blood vessel. The device (2) comprises a permanently joined sensor (70) for monitoring one or more physiological parameter for diagnostic or therapeutic purposes. Data access is as-

ured by a passive RF transponder, in communication with an external readout unit, providing as well to the energy supply of the sensor (70). The device is repositionable and retrievable by non-invasive methods, thanks to its specially adapted shape and to a joint section (20) for coupling with a grabbing device (45) mounted on a catheter (40).

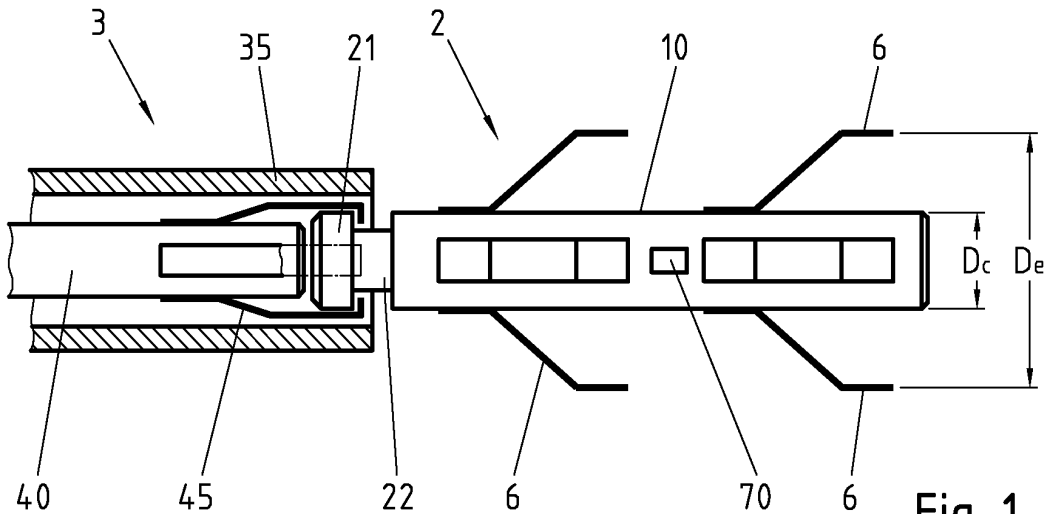

Fig. 1

DescriptionField of the invention

[0001] The present invention deals with an implantable device, comprising a removable part, for retrievably securing the device inside a body lumen, and a sensor, for measuring, logging and/or transmitting relevant body parameters.

Description of related art

[0002] Implantable devices have long been applied, in particular in conjunction with balloon angioplasty, to restore proper flow in constricted blood vessels. In this application the blood vessel is expanded with an inflatable balloon, guided into the desired section of the vessel by means of a catheter. The intravascular device or stent is then positioned inside the vessel to ensure that it maintains the enlarged diameter once the expanding balloon is removed.

[0003] On the other hand it is known to use miniaturized devices for performing diagnostic or research measurement inside the body of a human or an animal. Such devices are in general inserted inside a blood vessel or another body lumen by a suitable catheter. This procedure, even if it is only moderately invasive, must be performed in a medical establishment and does not allow prosecuting the measurement for an extended period of time or during patient's normal activities.

[0004] Moreover the known stenting devices are in general suitable for definitive implantation only. While safe and reliable procedures to position a stent into a body lumen are well established, this is not generally true for recovering or repositioning an already implanted device. Once a stent is deployed its emplacement is considered definitive and recovering or replacing it would often require invasive surgery.

Brief summary of the invention

[0005] An aim of the present invention is to provide a practical and safe device for performing accurate inner measurements for diagnostic, research or therapy, without interfering with patient's normal activities and in a minimally invasive way.

[0006] Another object of the present invention is to provide a replaceable intravascular device, which can safely and easily be recovered from its position inside the body, or moved to a different position, without the necessity of invasive techniques.

[0007] These objects are attained by the devices and method of the independent claims in the corresponding categories, while the remaining claims deal with preferred and alternatives embodiment and examples. In particular said objects are attained by an implantable device, for placement in a body lumen, preferably in a blood vessel, comprising:

an expandable section having a variable dimension, said variable dimension allowing a compressed value D_c for delivery to said body lumen and an expanded value D_e , larger than said compressed value D_c , for implantation in said body lumen ;

a link section at one end of said device, comprising a grip, for joining said device to a catheter, and for applying an axial force on said device;

at least one sensor permanently joined to said device;

wherein said device is arranged for reacting to an axial pulling force to said grip, by assuming said compressed value of said variable dimension, for retrieval or repositioning of said implantable device ; and by an apparatus for positioning an implantable device according to claim 1, comprising:

a flexible catheter, inserted into a flexible sleeve; a grasp section, fixed to the tip of said catheter, for cooperating with said link section of said implantable device, said clasp section comprising at least two opposed flexible fingers;

said flexible sleeve interacting with said flexible fingers for opening and closing them on said link section, and interacting with said expandable section for reducing said variable dimension of said implantable device.

Brief Description of the Drawings

[0008] The invention will be better comprised from the study of the following description and claims and with reference to the appended figures wherein:

- figure 1 shows an implantable device according to the invention, connected to a delivery/recovery apparatus according to the invention;
- figures 2a to 2d represent a sequence of actions describing the use of the device and the apparatus of figure 1.
- figure 3 represent an alternative embodiment of the implantable device according to the invention, comprising a flexible tether.
- figure 4a and 4b show another embodiment of the invention wherein the implantable device comprises a tubular mesh;
- figures 5 and 6 illustrate two different fashions of realizing the connexion between the implantable device and the positioning apparatus of the invention;
- figures 7, 8, 9, 10 and 11 shows other embodiments

of the implantable device according to the invention;

- figure 12 shows an application of the device of the invention in conjunction with a vascular stent.

Detailed Description of the Invention

[0009] According to a first embodiment of the present invention, the implantable device 2 comprises a core 10, of elongated shape, on which are disposed at least a plurality of elastic struts 6 which can assume all the positions between the fully released configuration visible in figure 1, in which the struts 6 extend radially from the body 10, and a compressed configuration, in which the struts are almost in full contact with the core 10.

[0010] The transversal diameter of the device 2 is therefore variable according to the configuration of the flexible struts 6. In their fully released position the struts 6 define the maximum expanded diameter D_e of the device, while the compressed diameter D_c is obtained when the struts 6 are in full contact with the core 10.

[0011] In this particular example of the invention the struts 6 are in number of 8, and disposed, as shown on figure 1, in two levels, each comprising four radial struts. The skilled person will understand however that the number of struts and their disposition could easily be modified, according to the circumstances and the destination of the implantable device 2.

[0012] The link section 20 is located at one extremity of the core 10, and its function is to allow repeatable engagement and connection with the grasp section placed on the delivery/recovery apparatus 3, also visible on figure 1. The link section comprises, in this embodiment of the invention, a round/cylindrical head 21, joined to the core by a relatively narrow neck 22.

[0013] The delivery/recovery apparatus 3 comprises a flexible catheter 40, enclosed in a flexible sleeve 35. On the tip of the catheter 40 is fixed a grasping device composed by the four flexible fingers 45. According to the relative position of the catheter 40 in the sleeve 45 the fingers can be retracted inside the sleeve 45, in which case they assume the closed configuration represented in figure 1, or they can extend forward from the sleeve 45, in which case their elasticity forces them in the open configuration shown on figure 2c.

[0014] The functioning of the implantable device 2 and of the apparatus 3 will now be explained in relation with figures 2a - 2d, showing a typical implantation sequence.

[0015] In figure 2a is visible the implantable device 2, connected to the catheter 40 by the fingers 45 closed on the neck 22 of the link section. The device 2 is fully retracted inside the sleeve 35.

[0016] In this configuration the sleeve 35 is inserted into the human or animal body, and guided until the tip of the apparatus 3, now containing the device 2, is at the place chosen for the implantation. The progress of the device into the body can for example be monitored

and followed using conventional X-ray techniques. To this effect the device 2 and the delivery/recovery apparatus 3 may be equipped with radio-opaque marks.

[0017] Once the position of the device 2 is satisfactory, the operator retracts the sleeve 35 (fig. 2b). The device 2 is still connected and axially maintained by the catheter 40. In this way the struts 6, now free from the sleeve 35, open themselves and anchor the device 2 inside the blood vessel 3.

[0018] By continuing the retraction of the sleeve 35 the fingers 45 finally get free, and open themselves (fig. 2c). The device 2 is now detached from the catheter 40.

[0019] Finally the catheter 35 is pulled back, and the fingers 45 retracted inside the sleeve 35. In this configuration the apparatus 3 can be extracted from the body, leaving the implantable device 2 in place in the body lumen 8.

[0020] A recovery sequence involves all the above steps in reverse order. Initially the delivery/recovery apparatus 3 is inserted in the body lumen 8, with the grasp section fully retracted inside the sleeve 35 (Fig. 2d). The catheter 45 is then pushed out of the sleeve 35 in order to expose and open the fingers 45 (Fig. 2c). During this phase the fingers 45 touch the walls of the body lumen 8, and align the tip the catheter 35 with the axis of the body lumen, simplifying the connection between delivery/recovery apparatus 3 and the implantable device 2. Once the tip of the catheter 35 is in contact with the link section of the implantable device, the sleeve 35 is advanced (fig. 2b), in order to close the fingers 45 on the neck 22, thereby locking and aligning the catheter 35 and the implantable device 2. Finally the edge of the sleeve 35 enters in contact with the struts 6 and forces them in the compressed configuration. The device 2 is now released from the lumen 8 and can be recovered inside the sleeve 35.

[0021] The grasp section of the delivery/recovery apparatus 3 can of course take also other forms, different from the hook-shaped fingers of figure 1. In a variant of the present embodiment represented on figure 5, the grasp section comprises two rectangular or oval loops 49.

[0022] The link section 20 of the device 2 can also take other forms than the round head if figure 1. For example, in the variant of figure 6, which will be explained in more detail later, the head 21 has the shape of a ball. In the example visible on figure 8 the link section comprises a wire loop 221.

[0023] The present invention is however not limited to the shapes described here by way of example for the join section of the device 2 and the grasp section of the delivery/recovery apparatus 3, but comprises as well all the many different shapes adapted to interoperate together for the realization of the invention.

[0024] The device 2 further comprises at least a permanently attached sensor 70. For example the sensor 70 may measure a physical property, like blood pressure sensor, fluid flow, temperature or electric heart or mus-

cle activity. The sensor 70 may also record a chemical blood parameter, like pH, glycaemia, electrolytes or gas concentration.

[0025] Preferably the sensor 70 communicates with an external readout unit (not shown) via a wireless connection. In this way the parameters acquired by the sensor 70 can be accessed whenever necessary, or automatically logged on a periodical basis in the readout unit for later analysis.

[0026] If requested, the readout unit may be arranged to trigger an alarm signal in case an abnormal situation, calling for urgent medical care is detected.

[0027] Advantageously the wireless link between the external readout unit and the sensor 70 could also provide the necessary energy source for the sensor operation. The link could for example comprise a backscattering passive transponder.

[0028] In this variant of the invention, the sensor 70 is only active when the readout unit sends an electromagnetic flux toward the implanted device 2. In this case the electrical signal picked up by the transponder antenna serves, after rectification and conversion, to supply the sensor 70. The requested measurement is then sent back to the readout unit by backscattering modulation or other transmission techniques.

[0029] Other wireless communication techniques, like for example HF, acousto-magnetic, electromagnetic, swept-RF or Macro-wave or others are also possible and comprised in the present invention.

[0030] By using a passive transponder, the need of an energy source in the implantable device is avoided, thus reducing the size of the device 2 and the hazard connected with electrochemical batteries. Autonomous energy sources may however also be employed, according to the circumstances.

[0031] In an alternative, not represented, variant of the present invention, the data recorded by the sensor 70 are logged in a permanent memory included in the implantable device 2. In this case no real-time telemetry link is required. Instead the data are analyzed in a second moment, when the implantable device 2 is removed from the patient's body.

[0032] According to this variant embodiment of the invention, the implantable device 2 may comprise an autonomous source of electrical energy, for example an electrochemical battery. Alternately, the implantable device 2 may be alimented by an external source, via a magnetic link or another wireless energy transmission technique.

[0033] According to another embodiment of the present invention, represented on figure 3, the sensor 70 is not rigidly joined to the device 2, but rather connected to it by a flexible tether 50.

[0034] This embodiment of the invention allows monitoring of body parameters in places that, due to their conformation or for other reason, would not be suitable for directly placing a device. An example of application for this embodiment of the present invention would be

the monitoring of blood pressure in an aneurism.

[0035] According to another embodiment of the present invention not represented in the figures, the device 2 includes a reservoir of a biologically active substance, which can be selectively put in fluid contact with the body lumen 8 by an appropriate command from an external unit in wireless communication with the implantable device 2. This embodiment of the invention comprises a hollow reservoir and an electrically actionable valve realized with known micro-fluidic and MEMS (microelectromechanical systems) techniques, for example by 2D or 3D photolithography, or by a LIGA process.

[0036] In another variant embodiment the device may contain elements loaded with a biologically active substance, which is passively released in the body, until the device is extracted, or the supply is used up.

[0037] According to the embodiment of the invention represented on figures 4a and 4b, the body of the implantable device 2 comprises a tubular elastic mesh 150 of biocompatible wire. The tubular mesh 150 has an expanded configuration, allowing it to adhere closely to the inner walls of the blood vessel 8, yet is sufficiently elastic to be compressed inside the sleeve 35 of the delivery/recovery apparatus 3. The link section consists, in this embodiment of the present invention, of a ball 21, connected to the mesh 150 by at least one wire 220, as it is visible on figure 6.

[0038] According to another embodiment of the present invention represented on figure 7, the device 2 comprises a plurality of curved smooth membranes 170 joined together by a common central edge 175. The outer edges 172 of the membranes 170 lie, in the deployed extended configuration, on the inner walls of the blood vessel 8, thereby securing the device 2 in place. To recover the device 2 the membranes 170 are bent elastically and / or rolled one on each other, by the combined action of the catheter 35 pulling on the ball 21 and of the edge of the sleeve 35 pushing on the wires 220, until the device 2 is fully retracted inside the sleeve 35. In this particular embodiment, the exposed surfaces are smooth and parallel to the fluid current, thereby opposing a low flow resistance, without disturbing laminar flow.

[0039] According to another embodiment of the present invention represented on figure 9, the device 2 comprises two flexible lateral plates 160, having a cylindrical surface, joined by the triangular or conical flexible surfaces 163. In the expanded state the lateral surfaces 160 contact the inner wall of the body lumen 8 and maintain the device in the desired position. The creases between lateral plates 160 and the connecting surfaces 163 can bend, compressing the device 2 inside the sleeve 35, as in the other embodiments.

[0040] According to another embodiment of the present invention represented on figure 10, the device 2 comprises an elongated core 10 and at least one flexible wire 180 comprising straight and bent sections, whose flexibility allows a compressed configuration for

fitting inside the sleeve 35 and an expanded configuration for anchoring inside the body lumen 3 having a lateral dimension larger than the lateral dimension of said compressed configuration.

[0041] Figures 11 represents a further embodiment of the present invention, in which the implantable device comprises two flexible arms 66, joined as to form a flexible "U", and the join section fixed on the curved section of the "U"

[0042] Figure 12 shows an application of the present invention in which the implantable device 2 is inserted in a permanent or semipermanent angioplasty stent 15. In this case the particular embodiment of figure 11 is shown, inside a tubular stent 15. The skilled person will understand, however, that all presented embodiment of the invention may be adapted for use in this manner. In this particular application, the device of the invention can for example be placed for a limited time, after an angioplasty operation, in the expanded body vessel. Thanks to this aspect of the invention it is possible to monitor or log blood pressure, flow constriction, or other clinical parameters, or deliver drugs *in situ*.

Claims

1. Implantable device (2), for placement in a body lumen, preferably in a blood vessel (8), comprising:

an expandable section having a variable dimension, said variable dimension allowing a compressed value (D_c) for delivery to said body lumen (8) and an expanded value (D_e), larger than said compressed value (D_c), for implantation in said body lumen (8);

a link section (20), at one end of said device (2) comprising a grip (21, 221), for joining said device (2) to a catheter (40), and for applying an axial force on said device (2);

at least one sensor (70) permanently joined to said device (2);

wherein said device (2) is arranged for reacting to an axial pulling force to said grip (21, 221), by assuming said compressed value (D_c) of said variable dimension, for retrieval or repositioning of said implantable device (2).

2. Implantable device according to claim 1, comprising an elongated core (10) and a plurality of elastic struts (6) having a released configuration, in which said elastic struts (6) radially protrude from said elongated core (10), and a compressed position, in which said elastic struts (6) are closer to said elongated core (10).

3. Implantable device according to claim 1, comprising a tubular mesh of elastic wire, whose diameter al-

lows a compressed value (D_c) and an expanded value (D_e), larger than said compressed value (D_c).

4. Implantable device according to claim 1, comprising a plurality of curved smooth membranes (170), parallel to the main axis of said device (2), allowing unobstructed fluid flow through said body lumen (8).

5. Implantable device according to claim 1, comprising a plurality of flexible lateral surfaces (160), for anchoring said device within said body lumen (8), bendably joined by a plurality of radial connection elements (163) allowing a compressed configuration having a lateral dimension (D_c) and an expanded configuration having a lateral dimension (D_e), larger than said lateral dimension (D_c) of said compressed configuration.

6. Implantable device according to claim 1, comprising an elongated core (10) and at least one flexible wire (180) comprising straight and bent sections, whose flexibility allows a compressed configuration having a lateral dimension (D_c) and an expanded configuration having a lateral dimension (D_e), larger than said lateral dimension (D_c) of said compressed configuration.

7. Implantable device according to one of the claims from 1 to 6, wherein at least a part of said sensor (70) is flexibly connected to said device, by a flexible tether (50).

8. Implantable device according to claims from 1 to 7, wherein said sensor (70), includes a communication device to communicate with an external read-out unit by a wireless link.

9. Implantable device according to claim 8, wherein said wireless link also provides energy supply for said sensor (70).

10. Implantable device according to claim 8, further comprising a reservoir, which can selectively be put in fluid communication with said body lumen upon a command received on said wireless link.

11. Implantable device according to claims 1 or 8, further comprising at least one release means, for releasing at least one substance comprised in said release means.

12. Implantable device according to one of the claims from 1 to 6, wherein said grip (21, 221) comprises a head (21) having a transversal dimension, and a neck (22) connecting said head (21) to said device (2), having a dimension smaller than said transversal dimension of said head (21).

13. Implantable device according to one of the claims from 1 to 6, wherein said grip (21, 221) is connected to said device (2) by at least one wire (220).
14. Implantable device according to one of the claims from 1 to 6, wherein said grip comprises a loop of wire (221).
15. Implantable device according to one of the claims from 1 to 14, wherein said sensor comprises at least one of: a temperature sensor; a pressure sensor; a chemical sensor, a fluid flow sensor, an ECG sensor, a pH sensor, an electrolyte sensor, a wireless communication device.
16. Apparatus (3) for positioning an implantable device (2) according to claim 1, comprising:
- a flexible catheter (40), inserted into a flexible sleeve (35);
a grasp section, fixed to the tip of said catheter (40), for cooperating with said link section (20) of said implantable device (2), said grasp section comprising at least two opposed flexible fingers (45);
said flexible sleeve (35) interacting with said flexible fingers (45) for opening and closing them on said link section (20) of said implantable device (2), and interacting with an expandable section of said implantable device (2) for reducing a variable dimension of said implantable device (2).
17. A combination of: an implantable device (2), for placement in a body lumen, and an apparatus (3) for positioning said implantable device (2), said implantable device (2) comprising:
- an expandable section having a variable dimension, said variable dimension allowing a compressed value (D_c) for delivery to said body lumen (8) and an expanded value (D_e), larger than said compressed value (D_c), for implantation in said body lumen (8);
a link section (20), at one end of said device (2) comprising a grip (21, 221), for joining said device (2) to a catheter (40), and for applying an axial force on said device (2);
at least a sensor (70) permanently joined to said device (2);
said apparatus comprising:
- a flexible catheter (40), inserted into a flexible sleeve (35);
a grasp section, fixed to the tip of said catheter (40), for cooperating with said link section (20) of said implantable device (2), said grasp section comprising at least two opposed flexible fingers (45); said flexible sleeve (35) interacting with said flexible fingers (45) for opening and closing them on said link section (20);
- wherein said flexible sleeve (35) interacts with said implantable device (2) by forcing it to assume said compressed value (D_c) of said variable dimension, when said device (2) is pulled by said flexible catheter (40) into said flexible sleeve (35).
18. Method for sensing a parameter within a body lumen, comprising:
- a step of delivering an implantable device (2) comprising a miniaturized sensor (70) in said body lumen;
a step of expanding said implantable device for anchoring it in said body lumen;
a step of contactless reading the value measured by said miniaturized sensor (70);
a step of retrieving said implantable device (2);
19. Method according to claim 18, wherein said step of contactless reading comprises transmitting said value on a wireless link, said wireless link also providing energy for the functioning of said sensor (70).
20. Method according to claim 18 or claim 19, wherein said device is implanted within a stent (15) in said body lumen (8).
21. Method according to claim 18 or claim 19, wherein said implantable device (2) is an implantable device according to one of the claims from 1 to 15.
22. Method according to claim 18 or claim 19, wherein said steps of delivering and said step of retrieving are carried out with the apparatus of claim 16.

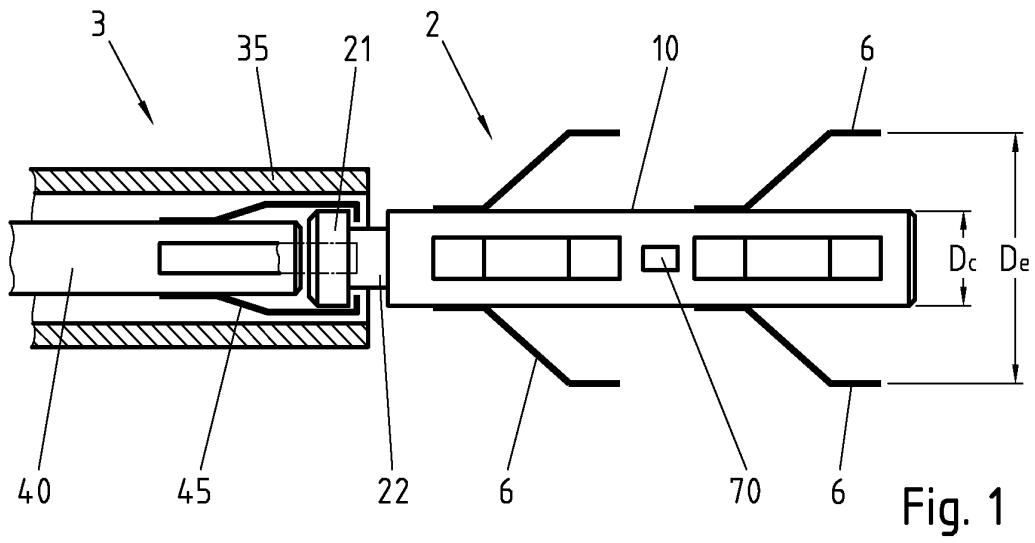

Fig. 1

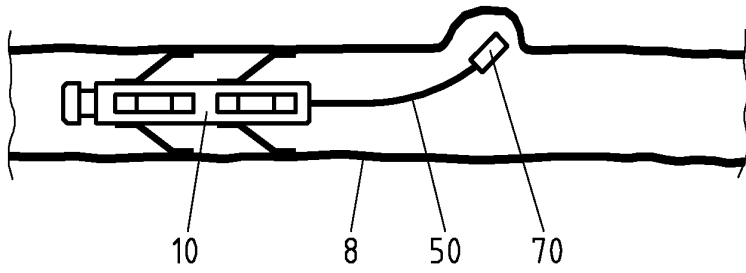

Fig. 3

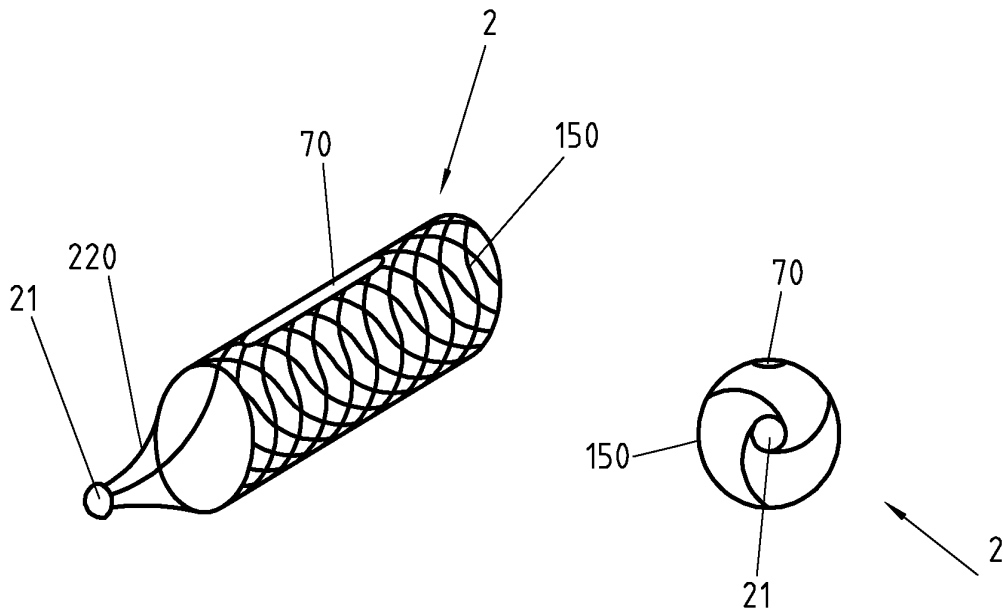

Fig. 4a

Fig. 4b

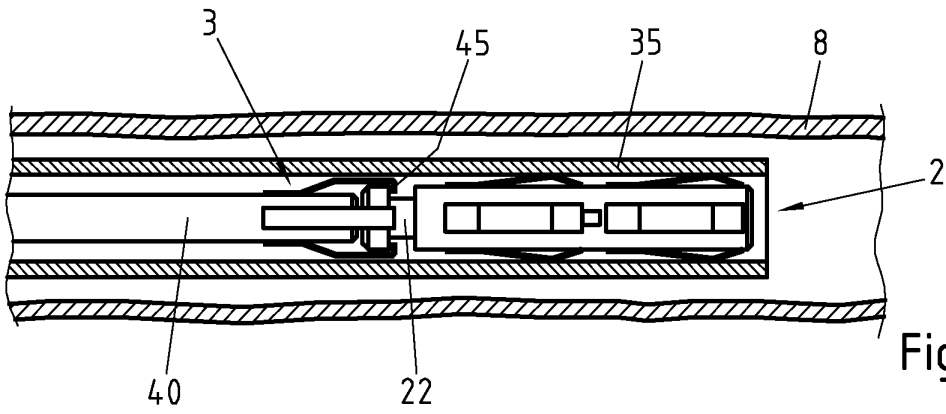

Fig. 2a

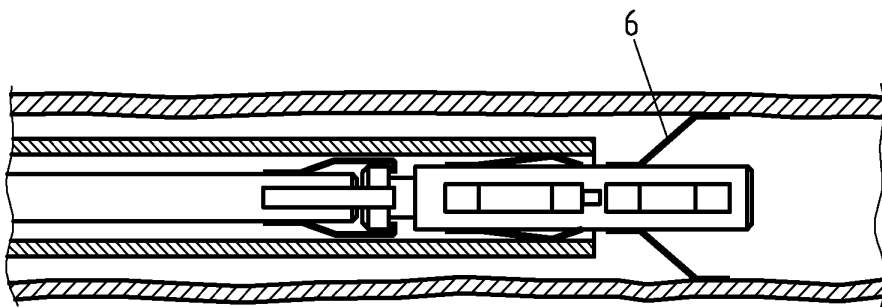

Fig. 2b

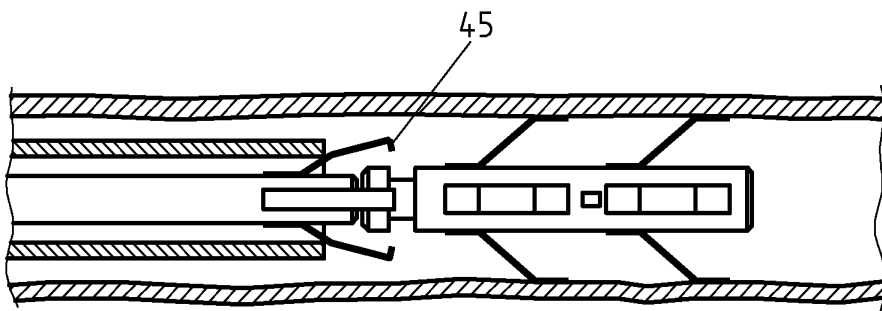

Fig. 2c

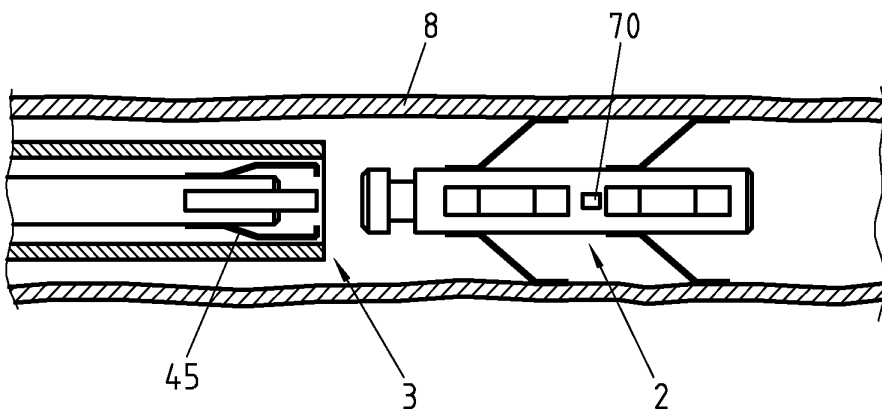
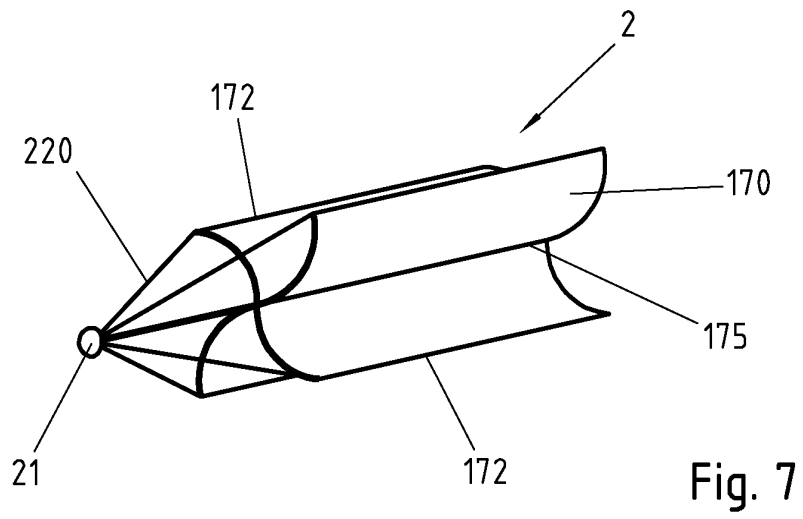
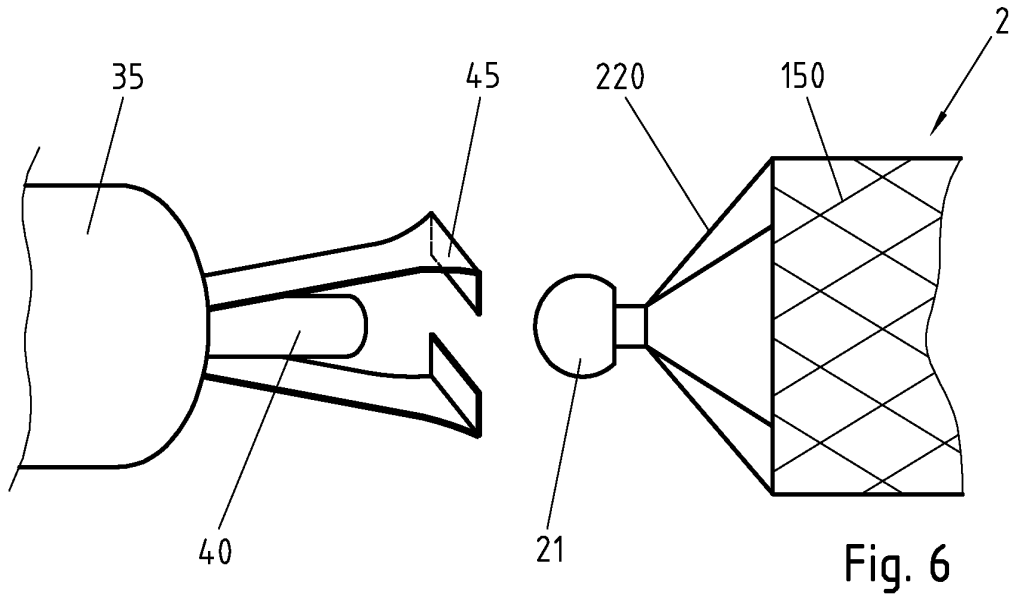
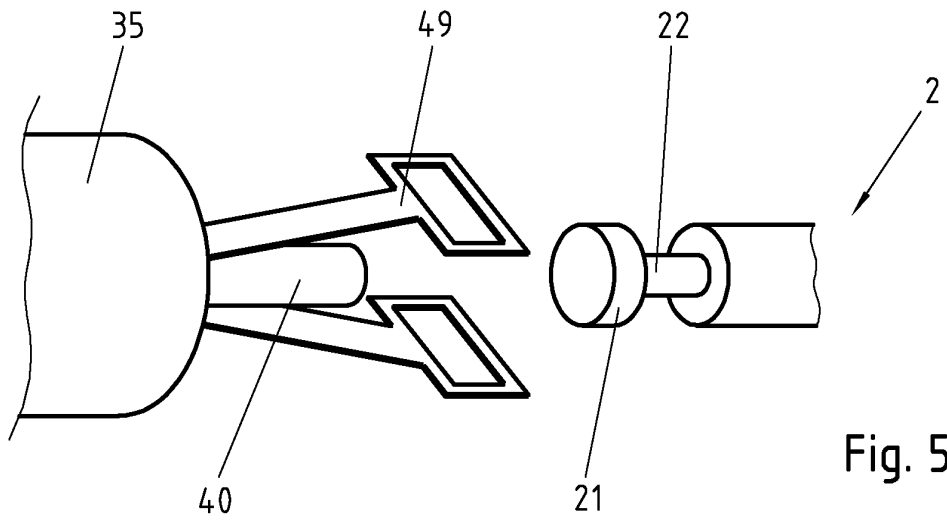

Fig. 2d



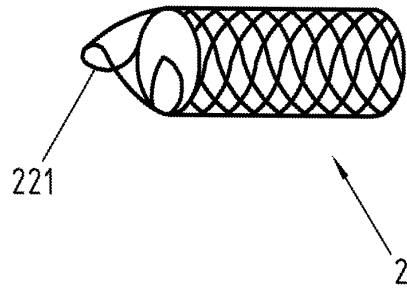

Fig. 8

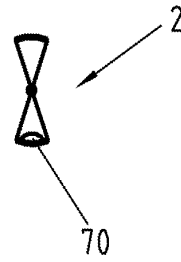
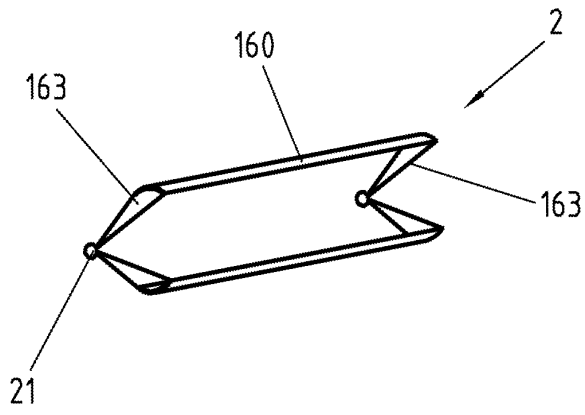

Fig. 9

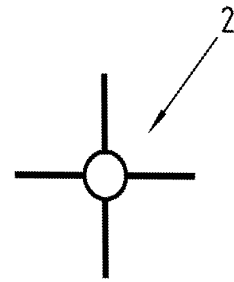
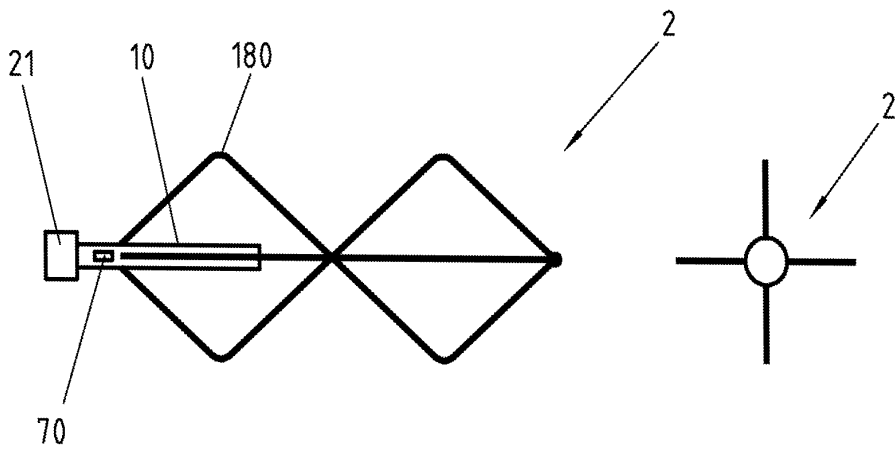

Fig. 10

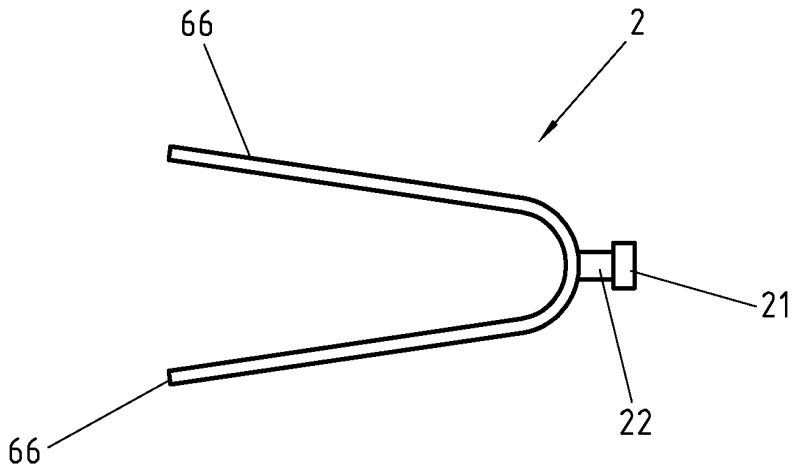

Fig. 11

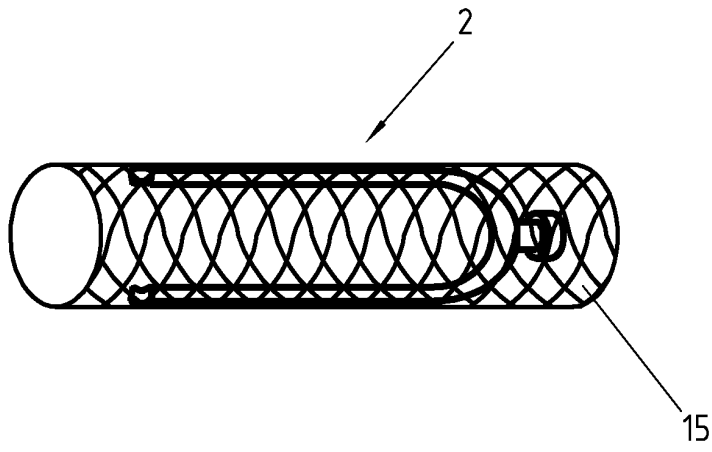

Fig. 12



European Patent Office

EUROPEAN SEARCH REPORT

Application Number
EP 03 10 1769

DOCUMENTS CONSIDERED TO BE RELEVANT			
Category	Citation of document with indication, where appropriate, of relevant passages	Relevant to claim	CLASSIFICATION OF THE APPLICATION (Int.Cl.7)
X A	US 4 886 065 A (COLLINS JR EARL R) 12 December 1989 (1989-12-12) * the whole document *	1,7,12, 16,17 2-6, 8-11, 13-15, 18-22	A61B5/00
X A	--- US 6 442 413 B1 (SILVER JAMES H) 27 August 2002 (2002-08-27) * column 19, line 29 - line 63; figure 7 *	18-21 1-17,22	
A	--- US 5 954 761 A (MACHEK JAMES E ET AL) 21 September 1999 (1999-09-21) * claim 23; figures 7-10 *	1-22	
			TECHNICAL FIELDS SEARCHED (Int.Cl.7)
			A61B
The present search report has been drawn up for all claims			
Place of search MUNICH		Date of completion of the search 19 November 2003	Examiner Mausser, T
<p>CATEGORY OF CITED DOCUMENTS</p> <p>X : particularly relevant if taken alone Y : particularly relevant if combined with another document of the same category A : technological background O : non-written disclosure P : intermediate document</p> <p>T : theory or principle underlying the invention E : earlier patent document, but published on, or after the filing date D : document cited in the application L : document cited for other reasons & : member of the same patent family, corresponding document</p>			

EPO FORM 1503 03 82 (P04C01)

**ANNEX TO THE EUROPEAN SEARCH REPORT
ON EUROPEAN PATENT APPLICATION NO.**

EP 03 10 1769

This annex lists the patent family members relating to the patent documents cited in the above-mentioned European search report. The members are as contained in the European Patent Office EDP file on
The European Patent Office is in no way liable for these particulars which are merely given for the purpose of information.

19-11-2003

Patent document cited in search report		Publication date	Patent family member(s)	Publication date
US 4886065	A	12-12-1989	NONE	

US 6442413	B1	27-08-2002	AU 5965601 A	26-11-2001
			WO 0187137 A2	22-11-2001
			US 2002128546 A1	12-09-2002
			US 2003009093 A1	09-01-2003
			US 2003114735 A1	19-06-2003

US 5954761	A	21-09-1999	EP 0968028 A1	05-01-2000
			JP 2001517995 T	09-10-2001
			WO 9842403 A1	01-10-1998

专利名称(译)	仪器可检索的可植入装置		
公开(公告)号	EP1488735A1	公开(公告)日	2004-12-22
申请号	EP2003101769	申请日	2003-06-17
[标]申请(专利权)人(译)	MOSER RAYMOND		
申请(专利权)人(译)	MOSER , RAYMOND		
当前申请(专利权)人(译)	MOSER , RAYMOND		
[标]发明人	MOSER RAYMOND		
发明人	MOSER, RAYMOND		
IPC分类号	A61B5/0215 A61B5/042 A61B5/07 A61B5/00		
CPC分类号	A61B5/6876 A61B5/0215 A61B5/042 A61B5/076 A61B5/14546 A61B5/4839 A61B5/6862 A61B5/6886		
其他公开文献	EP1488735B1		
外部链接	Espacenet		

摘要(译)

仪器化可回收植入装置 (2) , 包括可扩张部分 , 用于放置在体腔内 , 优选放置在血管中。装置 (2) 包括永久连接的传感器 (70) , 用于监测一个或多个生理参数以用于诊断或治疗目的。通过与外部读出单元通信的无源RF应答器确保数据访问 , 同时提供传感器 (70) 的能量供应。由于其特别适合的形状 , 该装置可通过非侵入性方法重新定位和检索 , 并且可通过连接部分 (20) 与安装在导管 (40) 上的抓取装置 (45) 连接。

