



(11) **EP 1 204 368 B1**

(12) **EUROPEAN PATENT SPECIFICATION**

(45) Date of publication and mention of the grant of the patent:
13.08.2008 Bulletin 2008/33

(51) Int Cl.:
A61B 5/00 (2006.01) **A61M 25/00** (2006.01)
A61F 7/12 (2006.01)

(21) Application number: **00968972.0**

(86) International application number:
PCT/US2000/040654

(22) Date of filing: **16.08.2000**

(87) International publication number:
WO 2001/012061 (22.02.2001 Gazette 2001/08)

(54) **CENTRAL VENOUS CATHETER WITH HEAT EXCHANGE PROPERTIES**

ZENTRALVENÖSER KATHETER MIT WÄRMETAUSCHEIGENSCHAFTEN

CATHETER VEINEUX CENTRAL POSSEDANT DES PROPRIETES D'ECHANGE THERMIQUE

(84) Designated Contracting States:
AT BE CH CY DE DK ES FI FR GB GR IE IT LI LU MC NL PT SE

(30) Priority: **18.08.1999 US 376524**

(43) Date of publication of application:
15.05.2002 Bulletin 2002/20

(60) Divisional application:
08151320.2 / 1 915 943

(73) Proprietor: **Alsius Corporation**
Irvine,
California 92618 (US)

(72) Inventors:
• **SHIMADA, Lynn, M.**
Orange, CA 92869 (US)
• **WORTHEN, William, J.**
Coto de Caza, CA 92679 (US)

- **EVANS, Scott, M.**
Santa Ana, CA 92705 (US)
- **LUO, Xia**
Los Angeles, CA 90045 (US)
- **PECOR, Robert**
Aliso Viejo, CA 92656 (US)
- **WALKER, Blair**
Mission Viejo, CA 92691 (US)

(74) Representative: **Shortt, Peter Bernard**
TOMKINS & CO.,
5 Dartmouth Road
Dublin 6 (IE)

(56) References cited:
WO-A-93/04727 **WO-A-98/40017**
WO-A-99/27862 **US-A- 5 304 214**
US-A- 5 437 673 **US-A- 5 542 928**
US-A- 5 733 319 **US-A- 5 868 735**

EP 1 204 368 B1

Note: Within nine months of the publication of the mention of the grant of the European patent in the European Patent Bulletin, any person may give notice to the European Patent Office of opposition to that patent, in accordance with the Implementing Regulations. Notice of opposition shall not be deemed to have been filed until the opposition fee has been paid. (Art. 99(1) European Patent Convention).

Description**FIELD OF THE INVENTION**

[0001] The present invention relates generally an apparatus for cooling patients for therapeutic purposes, and more particularly to systems for establishing central venous access while providing a means for cooling a patient.

BACKGROUND

[0002] It has been discovered that the medical outcome for a patient suffering from severe brain trauma or from ischemia caused by stroke or heart attack is degraded if the patient's body temperature rises above normal (38°C). It is further believed that the medical outcome for many such patients might be significantly improved if the patients were to be cooled relatively quickly for a short period, e.g., 24-72 hours. Apart from the therapeutic benefits of hypothermia, the outcomes for brain trauma or ischemia patients that develop fevers is worse than for patients that do not develop fevers. Consequently temperature management for such patients is important, even when hypothermia is not to be used to treat the patients. Moreover, prophylactic short-term hypothermia might help patients undergoing minimally invasive heart surgery and aneurysm surgery.

[0003] The affected organ, in any case, is the brain. Accordingly, systems and methods have been disclosed that propose cooling blood flowing to the brain through the carotid artery. An example of such systems and methods is disclosed in now published U.S. patent 6126684 (app. serial no. 09/063,984, filed April 21, 1998.) owned by the present assignee

[0004] In the referenced application, various catheters are disclosed which can be advanced into a patient's carotid artery and through which coolant can be pumped in a closed circuit, to remove heat from the blood in the carotid artery and thereby cool the brain. The referenced devices have the advantage over other methods of cooling (e.g., wrapping patients in cold blankets) of being controllable, relatively easy to use, and of being capable of rapidly cooling and maintaining blood temperature at a desired set point.

[0005] As recognized in now published US Patent 6338727 (U.S. pat. app. serial no. 09/133,813, filed August 13, 1998) owned by the present assignee the above-mentioned advantages in treating brain trauma/ ischemic patients by cooling can also be realized by cooling the patient's entire body, i.e., by inducing systemic hypothermia. The advantage of systemic hypothermia is that, as recognized by the present assignee, to induce systemic hypothermia a cooling catheter or other cooling device need not be advanced into the blood supply of the brain, but rather can be easily and quickly placed into the relatively large vena cava of the central venous system.

[0006] Moreover, since many patients already are intubated with central venous catheters for other clinically approved purposes anyway, providing a central venous catheter that can also cool the blood, if only to manage temperature and thereby ameliorate fever spikes, requires no additional surgical procedures for those patients. A cooling central venous catheter is disclosed in the present assignee's co-pending U.S. patent application serial no. 09/253,109, filed February 19, 1999 (now published as WO 00/48670) The present inventions are directed to central venous cooling devices.

SUMMARY OF THE INVENTION

[0007] The invention comprises a central venous line catheter with heat exchange properties including an introducer sheath, comprising a hollow body defining a proximal end, a distal end positionable in a patient, and at least one first lumen extending therebetween, the body also defining a coolant supply lumen and a coolant return lumen, a barrier in the first lumen at or near the proximal end of the body for selectively blocking the first lumen, and a distally-located heat transfer region associated with the body and communicating with the coolant supply and return lumens, as claimed in claim 1 with preformed embodiments in the dependent claims.

[0008] An introducer sheath for a central venous line catheter includes a hollow body defining a proximal end, a distal end positionable in a patient, and at least one catheter placement lumen extending therebetween. A barrier such as a septum or hemostasis valve is in the lumen at or near the proximal end of the body for selectively blocking the lumen, and at least one temperature sensor such as a thermistor or thermocouple is mounted on the body at or near the distal end for generating a temperature signal. The catheter can include at least one distally-located cooling membrane.

[0009] The body of the sheath further includes a coolant supply lumen and a coolant return lumen. Both the coolant supply lumen and coolant return lumen communicate with a distally-located heat transfer region associated with the body. The heat transfer region can be established by at least one membrane that is attached to the body, or by at least one distally-located fluid passageway that is formed in the body.

[0010] The introducer sheath for a central venous line catheter includes a hollow body defining a proximal end, a distal end positionable in a patient, and at least one catheter placement lumen extending therebetween. The body also defines a coolant supply lumen and a coolant return lumen. A barrier is disposed in the catheter placement lumen at or near the proximal end of the body for selectively blocking the catheter placement lumen, and a distally-located heat transfer region is associated with the body in communication with the coolant supply and return lumens.

[0011] In another aspect, a heat exchange catheter includes a catheter body defining at least a coolant supply

lumen, a coolant return lumen, and an air lumen. A cooling membrane defines a chamber that communicates with the coolant supply and return lumens, and an inflation balloon is disposed in the chamber. The inflation balloon is selectively movable between an inflated configuration, wherein the inflation balloon causes coolant to flow near an outer surface of the cooling membrane to thereby effect relatively greater heat exchange with the blood, and a deflated configuration, wherein coolant tends to flow through the cooling membrane with a laminar flow characteristic nearer the catheter body than the outer surface of the cooling membrane.

[0012] In still another aspect, a central venous access system includes a multi-lumen catheter, at least one heat exchange membrane or balloon located distally on the catheter and communicating with at least one coolant lumen of the catheter, and a heat exchange system communicating with at least the coolant lumen. Coolant is circulated between the heat exchange system and the membrane or balloon to effect heat exchange with a patient. At least one holder is engageable with the catheter to hold the catheter onto a patient. Also, a central venous system communicates with at least one lumen of the catheter.

[0013] The details of the present invention, both as to its structure and operation, can best be understood in reference to the accompanying drawings, in which like reference numerals refer to like parts, and in which:

BRIEF DESCRIPTION OF THE DRAWINGS

[0014]

Figure 1 is an exploded perspective view of a first embodiment of an entry sheath for a venous catheter, schematically showing a cooling system in communication with the catheter;

Figure 1A is a longitudinal cross-section as would be seen along the line 1A-1A in Figure 1, of an alternate balloon configuration for the catheter shown in Figure 1;

Figure 2 is a perspective view of a second example of an entry sheath, configured for providing cooling capability in a patient's central venous system;

Figure 3 is a cross-sectional view as seen along the line 3-3 in Figure 2;

Figure 3A is a cross-sectional view of an alternate sheath that includes a distal cooling balloon, as would be seen along the line 3-3 in Figure 2;

Figure 4 is a perspective view of a so-called jugular bulb catheter configured for cooling a patient, schematically showing various jugular bulb components and a cooling system connected to the catheter;

Figure 5 is a cross-sectional view as seen along the line 5-5 in Figure 4;

Figure 6 is a perspective view of a dialysis catheter configured for cooling a patient, schematically showing various dialysis components and a cooling sys-

tem connected to the catheter;

Figure 7 is a cross-sectional view as seen along the line 7-7 in Figure 6;

Figure 8 is a perspective view of a Foley catheter configured for cooling a patient, schematically showing various Foley catheter components and a cooling system connected to the catheter, and

Figure 9 is a cross-sectional view as seen along the line 9-9 in Figure 8.

DETAILED DESCRIPTION OF THE PREFERRED EMBODIMENT

[0015] Referring initially to Figure 1, a therapeutic catheter system, generally designated 10, is shown for establishing and maintaining hypothermia in a patient, or for attenuating a fever spike in a patient and then maintaining normal body temperature in the patient, or for returning a hypothermic patient to normothermic. Commencing the description of the system 10 at the proximal end, as shown the system 10 includes a cooling system 12 that can be a water-bath system or a TEC-based system such as either of the systems disclosed in now published US Patent 6146411(U.S. patent application serial no. 09/220,897, filed December 24, 1998) or now published U.S. Patent 6019783(U.S. patent application serial no. 09/260,950, filed March 2, 1999),. In any case, the coolant system 12 provides coolant such as saline water through a coolant supply line 14, and coolant is returned to the source 12 via a coolant return line 16. A catheter, generally designated 18, includes respective coolant supply and return lumens that communicate with the lines 14, 16 to establish a closed circuit coolant path between the catheter 18 and coolant source 12.

[0016] In one preferred embodiment, the catheter 18 is any one of the catheters disclosed in the above-referenced priority applications, For example, the catheter 18 can be the catheter disclosed in U.S. patent application serial no. 09/253,109, filed February 19, 1999, which catheter includes a holder 18a to hold the catheter onto a patient for long-term intubation. The above-referenced application discloses an exemplary anchor that can establish the holder 18a. In addition to the structure disclosed in the above-referenced application, the in-growth flange set forth in U.S. PaL No. 4,578,063 can be used as the present holder, or the anchoring systems set forth in U.S. Pat. Nos. 5,693,032 or 5,192,274 can be used, or the anchoring tape set forth in U.S. Pat. No. 3,677,250 can be used, or suture thread can be wound around the catheter body and attached to the patient to establish the holder. Also, one or more central venous systems 19 communicate with one or more lumens of the catheter 18 via respective tubes 19a (only a single system 19 shown for clarity). The central venous system 19 can be, e.g., a source of medicament to be infused into a patient's central venous system, or a syringe or other device for extracting central venous blood from a patient, or a pressure monitoring or blood gas monitoring or temperature

monitoring system.

[0017] Alternatively, the catheter 18 can be the modified catheter 20 shown in Figure 1A, which in all essential respects is identical to the two-balloon catheter set forth in U.S. patent application serial no. 09/305,613, filed May 5, 1999, now published (WO 00/66053) with the following exceptions.

[0018] As shown in Figure 1A, each of the two cooling balloons (only a single cooling balloon 22 is shown for clarity of disclosure) of the catheter 20 surrounds a respective inflation balloon 24. Coolant from a cooling system 26 or other coolant source enters each cooling balloon 22 through a coolant supply lumen 28 and coolant supply port or ports 30 and exits the cooling balloon 22 through a coolant exit port or ports 32 and coolant return lumen 34.

[0019] Additionally, Inflation fluid such as air can be directed into the inflation balloon 24 from an air source 36 through an inflation lumen 38 and air port or ports 40 to inflate the inflation balloon 24. Air can be exhausted from the inflation balloon 24 back through the inflation lumen 38 to collapse the inflation balloon 24. With this structure, the inflation balloon 24 can be selectively moved between an inflated configuration (shown), wherein the inflation balloon 24 causes coolant to flow near the outer surface of the respective cooling balloon 22 and thereby effect relatively greater heat exchange with the blood, and a deflated configuration, wherein coolant tends to flow through the cooling balloon 22 with a laminar flow characteristic nearer the body of the catheter 20 than the outer surface of the catheter.

[0020] Referring back to Figure 1, the catheter 18 can be introduced into a patient through an elongated hollow plastic introducer sheath 42 having a hollow body 42A and a side port 43 connected to the body 42A. The sheath 42 preferably is coated with an anti-microbial agent, and it can also be coated with an anti-clotting substance such as heparin.

[0021] As shown, the sheath 42 includes a proximal end 44 and an open distal end 46, it being understood that a working lumen through which the catheter 18 (or other catheter, conventional or otherwise) can be advanced extends between the proximal end 44 and distal end 46 of the sheath 42. A barrier 48 such as a septum or hemostasis valve or other barrier selectively blocks the working lumen. The catheter 18 can be advanced through the barrier 48, with the barrier 48 sealing against the catheter 18. Upon removal of the catheter 18, the barrier 48 closes to prevent backflow through the working lumen out of the proximal end 44 of the sheath 42.

[0022] In the preferred embodiment shown, a temperature sensor 50 is mounted on the sheath 42 at or near the distal end 46 to sense the temperature of blood flowing past the distal end 46. The sensor 50 can be a thermistor or thermocouple or other suitable temperature sensing device. In any case, the sensor 50 is operably connected to the cooling system 12 as schematically indicated by the dashed line 52, to provide temperature

feedback to the system 12. This connection can be made by wireless transmission or through a wire or fiber that extends through the wall of the sheath 42. The sensor 50 can be mounted on the sheath 42 by solvent bonding or disposed in a lumen of the sheath 42, or attached to a wire that is disposed in a lumen of the sheath 42, with the sensor hanging outside the sheath 42.

[0023] Figure 2 shows that instead of a cooling catheter 18/20, a non-cooling catheter 54 such as a conventional central venous catheter or a Swan-Ganz catheter as exemplified in U.S. Patent No. 3,995,623 can be provided, this does not form part of the invention. In this case, a sheath 56 which is in all essential respects identical to the sheath 42 shown in Figure 1, with the following exceptions, can be provided. The sheath 56 includes a central working lumen 58 (Figure 3) for receiving the catheter 54 therein in slidable engagement, and at least along a distal segment of the sheath 56 coolant supply and return lumens 60, 62 surround the working lumen 58 to establish a distally-located heat transfer region. Accordingly, in the embodiment shown in Figures 2 and 3 a heat transfer region is established by at least one distally-located fluid passageway (e.g., either or both of the lumens 60, 62) that is formed in the body 66 of the sheath 56.

[0024] As shown best in Figure 3, the working lumen 58 is defined by a central lumen wall 64, with the supply and return lumens 60, 62 being established between the wall 64 and an outer wall 66 of the sheath 56. Separator ribs 68, 70 extend laterally between the walls 64, 66 along the length of the coolant supply and return lumens 64, 66 to separate the coolant supply and return lumens 60, 62.

[0025] In accordance with the present invention, the coolant supply and return lumens 60, 62 communicate, via a side port 72 having supply and return tubes 74, 76, with a cooling system 78 that is in all essential respects identical to the system 12 shown in Figure 1. If desired, a temperature sensor 80 can be mounted on the sheath 56 to provide temperature feedback to the cooling system 78 in accordance with principles set forth above.

[0026] Alternatively, as shown in Figure 3A a thin-walled cooling balloon or membrane 82 can surround a distal segment of the outer wall 66 of the sheath 56, to establish a cooling chamber 84 between the outer wall 66 and the balloon or membrane 82. The embodiment of the sheath 56 shown in Figure 3A would then function essentially analogously to the cooling catheters disclosed in the above-referenced patent applications, with the coolant from the system 78 entering and exiting the chamber 84 through respective coolant supply and return passageways in the sheath 56. In the embodiment shown in Figure 3A, the distally-located heat transfer region is established by the balloon or membrane 82.

[0027] Now referring to Figures 4 and 5, a jugular vein catheter system, generally designated 100, includes a jugular catheter body 102 bearing an oxygen sensor, shown schematically at 104. The jugular catheter can be the fiberoptic intravascular catheter sold under the trade-

mark "Opticath" by Abbot Critical Care Systems, or a jugular catheter made by Baxter International, with the exceptions noted below.

[0028] An optical fiber 106 is connected to the oxygen sensor 104, and the fiber 106 terminates in an optical connection 108. In turn, the connector 108 can be connected to an oxygen measuring system 110. Further, a temperature sensor, shown schematically at 112, is supported by the body and is operably connected through a sensor lumen 113 (Figure 5) with a monitoring system 114. Both the oxygen and temperature sensor connecting lines can extend through the sensor lumen 113. Moreover, a pressure sensor, shown schematically at 116, is supported on the body 102, and the pressure sensor 116 communicates via a pressure/infusion lumen 118 and luer-like fitting 120 with a pressure sensing system 122 or with a drug infusion device 124, such as a syringe or IV bag.

[0029] Unlike conventional jugular bulb catheters, however, the catheter 102 shown in Figures 4 and 5 includes a distally-located balloon or membrane 126. The balloon or membrane 126 is attached to the catheter body and communicates with coolant supply and return lumens 128, 130 that are formed in the catheter body. In turn, the coolant lumens 128, 130 communicate via coolant supply and return lines 132, 134 with a cooling system 136. With this structure, coolant can be circulated in the balloon or membrane 126 to effect heat exchange with a patient's body.

[0030] In addition to the above heat exchange structures, an arterial catheter system, generally designated 150 in Figures 6 and 7, can be provided to effect heat exchange with a patient. The system 150 includes an arterial catheter body 152. In accordance with arterial catheter principles, the body 152 includes a blood supply lumen 154 and a blood return lumen 156, both of which communicate with a dialysis blood source 158 via blood supply and return tubes 160, 162 for undertaking dialysis of a patient's blood.

[0031] The arterial catheter system 150 also includes a heat exchange region associated with a distal segment of the catheter body 152. The body 152 includes coolant supply and return lumens 164, 166 that communicate with a cooling system 168 via supply and return tubes 170, 172, with the lumens 164, 166 establishing the heat exchange region. Or, the heat exchange region can be established by at least one distally-located balloon or membrane 174 that communicates with the supply and return lumens 166, 168 in accordance with present principles.

[0032] Figures 8 and 9 show a Foley catheter, generally designated 200, that is adapted for use for cooling the interior of a patient's bladder, to effect patient cooling. As shown, the catheter 200 includes a flexible resilient catheter body 202 terminating in a central fluid drainage tube 204 that communicates with a urine drainage lumen 206 (Figure 9) in the body 202. The drainage tube 204 can be connected to a fluid collection receptacle 208 in

accordance with Foley catheter principles known in the art. Also, the body 202 terminates in a temperature connector tube 210, and a temperature lead 212 extends through the connector tube 210 and a temperature lead lumen 214 (Figure 9) for connecting a temperature sensor 216 that is distally located on the body 202 with a temperature monitor system 218. Moreover, a drug infusion tube 220 can be connected to a drug infusion source 222 to infuse drugs into the bladder of a patient through the drug infusion tube 220 and a drug infusion lumen 224 that communicates with the drug infusion tube 220.

[0033] In addition to the conventional Foley catheter structure described above, the catheter 200 shown in Figures 8 and 9 includes coolant supply and return lumens 226, 228 that communicate with at least one balloon or membrane 230 that is distally located on the catheter body 202 in accordance with principles set forth above. Coolant such as saline from a cooling system 232 is circulated through coolant supply and return lines 234, 236, coolant lumens 226, 228, and balloon or membrane 230 in a closed loop to remove heat from a bladder of a patient into which the catheter 200 has been advanced. It is to be understood that while Figure 9 illustrates one lumen design layout, other layouts can be used. It is to be further understood that the cooling system 232 is in all essential respects identical in operation and construction to the above-described cooling systems. If desired, the temperature monitor system 218 can be connected to the cooling system 232 as indicated at the line 236 to provide temperature feedback to the cooling system 232.

[0034] While the particular CENTRAL VENOUS CATHETER WITH HEAT EXCHANGE PROPERTIES as herein shown and described in detail is fully capable of attaining the above-described objects of the invention, it is to be understood that it is the presently preferred embodiment of the present invention and is thus representative of the subject matter which is broadly contemplated by the present invention, that the scope of the present invention fully encompasses other embodiments which may become obvious to those skilled in the art, and that the scope of the present invention is accordingly to be limited by nothing other than the appended claims, in which reference to an element in the singular is not intended to mean "one and only one" unless explicitly so stated, but rather "one or more". All structural and functional equivalents to the elements of the above-described preferred embodiment that are known or later come to be known to those of ordinary skill in the art are expressly incorporated herein by reference and are intended to be encompassed by the present claims. Moreover, it is not necessary for a device to address each and every problem sought to be solved by the present invention, for it to be encompassed by the present claims. Furthermore, no element, component, or method step in the present disclosure is intended to be dedicated to the public regardless of whether the element or component is explicitly recited in the claims.

Claims

1. A central venous line catheter (18) with heat exchange properties including an introducer sheath (42), said introducer sheath (42) comprising :
- 5
- a hollow body (42A) defining a proximal end (44), a distal end (46) positionable in a patient, and at least one catheter placement lumen (58) extending therebetween, the body also defining a coolant supply lumen (60) and a coolant return lumen (62);
- 10
- a barrier (48) in the catheter placement lumen (58) at or near the proximal end (44) of the body (42A) for selectively blocking the catheter placement lumen (58); and
- 15
- a distally-located heat transfer region associated with the body (42A) and communicating with the coolant supply and return lumens (60, 62).
- 20
2. A catheter as claimed in claim 1 comprising:
- at least one temperature sensor (50) mounted on the body (42A) at or near the distal end (46) for generating a temperature signal.
- 25
3. A catheter as claimed in Claim 1 or Claim 2, wherein the catheter is a heat exchange catheter (20), comprising:
- 30
- a catheter body (102) defining at least a coolant supply lumen (28), a coolant return lumen (34), and an air lumen (38);
- 35
- at least a first cooling membrane (22) defining a chamber communicating with the coolant supply and return lumens (28, 34); and
- 40
- at least a first inflation balloon (24) disposed in the chamber and selectively movable between an inflated configuration, wherein the inflation balloon (24) causes coolant to flow near an outer surface of the cooling membrane (22) to thereby effect relatively greater heat exchange with the blood, and a deflated configuration, wherein coolant tends to flow through the cooling membrane (22) with a laminar flow characteristic nearer the catheter body (20) than the outer surface of the cooling membrane (22).
- 45
4. A catheter as claimed in any one of the preceding claims:
- 50
- wherein the catheter is a multi-lumen catheter (18, 54); and
- further comprising:
- 55
- at least one heat exchange membrane or balloon (22, 82) located distally on the catheter (18, 54) and communicating with at
- least one coolant lumen (28, 60) of the catheter (18, 54);
- a heat exchange system (12, 78) communicating with at least the coolant lumen (28, 60), coolant being circulated between the heat exchange system and the membrane or balloon (22, 82) to effect heat exchange with a patient; and
- at least one holder (18a) engageable with the catheter (18, 54) to hold the catheter (18, 54) onto a patient.
5. The catheter of Claim 4, further comprising a central venous system (19) communicating with at least one lumen of the catheter (18, 54).
6. A catheter as claimed in any one of the preceding claims wherein:
- the catheter is a multi-lumen catheter (18, 54); and
- further comprising:
- at least one heat exchange membrane or balloon (22, 82) located distally on the catheter (18, 54) and communicating with at least one coolant lumen (28, 60) of the catheter (18, 54);
- a heat exchange system (12, 78) communicating with at least the coolant lumen (28, 60), coolant being circulated between the heat exchange system and the membrane or balloon (22, 82) to effect heat exchange with a patient; and
- a central venous system (19) communicating with at least one lumen of the catheter (54).
7. A catheter as claimed in any of the preceding claims further comprising at least one holder (18a) engageable with the catheter (18, 54) to hold the catheter (18, 54) onto a patient.

Patentansprüche

1. Zentralvenöser Leitungskatheter (18) mit Wärmeaustauscheigenschaften, eine Inserter-Hülse (42) enthaltend, wobei die Inserter-Hülse (42) umfasst:
- einen Hohlkörper (42A), der ein proximales Ende (44), ein distales Ende (46), das in einem Patienten positioniert werden kann, und wenigstens ein Katheterplatzierungslumen (58), sich dazwischen erstreckend, definiert, wobei der Körper außerdem ein Kühlmittelzuführungslumen (60) und ein Kühlmittelrückführungslumen (62) definiert,

- eine Absperrung (48) in dem Katheterplatzierungslumen (58), an oder nahe dem proximalen Ende (44) des Körpers (42A), zum selektiven Blockieren des Katheterplatzierungslumens (58) und
- einen distal angeordneten Wärmeübertragungsbereich, verbunden mit dem Körper (42A) und mit dem Kühlmittelzuführungslumen (60) und dem Kühlmittelrückführungslumen (62) kommunizierend.
2. Katheter nach Anspruch 1, umfassend:
- wenigstens einen Temperatursensor (50), angebracht auf dem Körper (42A) an oder nahe dem distalen Ende (46), zum Erzeugen eines Temperatursignals.
3. Katheter nach Anspruch 1 oder 2, wobei der Katheter ein Wärmeaustauschkatheter (20) ist, der umfasst:
- einen Katheterkörper (102), der wenigstens ein Kühlmittelzuführungslumen (28), ein Kühlmittelrückführungslumen (34) und ein Luftlumen (38) definiert,
- wenigstens eine erste Kühlmembran (22), die eine Kammer definiert, die mit dem Kühlmittelzuführungslumen (28) und dem Kühlmittelrückführungslumen (34) kommuniziert, und
- einen ersten Inflationsballon (24), angeordnet in der Kammer und selektiv bewegbar zwischen einer aufgeblasenen Konfiguration, in der der Ballon (24) bewirkt, dass das Kühlmittel nahe einer Außenfläche der Kühlmembran (22) strömt, um **dadurch** einen relativ größeren Wärmeaustausch mit dem Blut herbeizuführen, und einer entleerten Konfiguration, in der das Kühlmittel die Tendenz hat, mit einer laminaren Strömungscharakteristik, näher dem Katheterkörper (20) anstelle der Außenfläche der Kühlmembran (22), durch die Kühlmembran (22) zu strömen.
4. Katheter nach einem der vorhergehenden Ansprüche, wobei der Katheter ein Multi-Lumen-Katheter (18, 54) ist und des Weiteren umfasst:
- wenigstens eine Wärmeaustauschmembran oder wenigstens einen Wärmeaustauschballon (22, 82), distal auf dem Katheter (18, 54) angeordnet und mit wenigstens einem Kühlmittellumen (28, 60) des Katheters (18, 54) kommunizierend,
- ein Wärmeaustauschsystem (12, 78), mit wenigstens dem Kühlmittellumen (28, 60) kommunizierend, wobei zwischen dem Wärmeaustauschsystem und der Membran oder dem Ballon (22, 28) Kühlmittel zirkuliert wird, um Wärmeaustausch mit einem Patienten zu bewirken, und ein zentralvenöses System (19), mit dem wenigstens ein Lumen des Katheters (54) kommunizierend.
5. Katheter nach Anspruch 4, das des Weiteren ein zentralvenöses System (19) enthält, das mit wenigstens einem Lumen des Katheters (18, 54) kommuniziert.
6. Katheter nach einem der vorhergehenden Ansprüche, wobei
- der Katheter ein Multi-Lumen-Katheter (18, 54) ist und des Weiteren umfasst:
- wenigstens eine Wärmeaustauschmembran oder wenigstens einen Wärmeaustauschballon (22, 82), distal auf dem Katheter (18, 54) angeordnet und mit wenigstens einem Kühlmittellumen (28, 60) des Katheters (18, 54) kommunizierend,
- ein Wärmeaustauschsystem (12, 78), mit dem wenigstens ein Kühlmittellumen (28, 60) kommunizierend, wobei zwischen dem Wärmeaustauschsystem und der Membran oder dem Ballon (22, 28) Kühlmittel zirkuliert wird, um Wärmeaustausch mit einem Patienten zu bewirken, und ein zentralvenöses System (19), mit dem wenigstens ein Lumen des Katheters (54) kommunizierend.
7. Katheter nach einem der vorhergehenden Ansprüche, der wenigstens einen Halter (18a) umfasst, der mit dem Katheter (18, 54) in Eingriff gebracht werden kann, um den Katheter (18, 54) auf dem Patienten zu halten.

Revendications

1. Cathéter veineux central (18) possédant des propriétés d'échange thermique, comprenant une gaine d'intubateur (42), ladite gaine d'intubateur (42) comprenant :

un corps creux (42A) définissant une extrémité proximale (44), une extrémité distale (46) pouvant être positionnée dans un patient, et au moins une lumière (58) de mise en place de cathéter, s'étendant entre elles, le corps définissant également une lumière (60) d'arrivée de fluide de refroidissement et une lumière (62) de retour de fluide de refroidissement;

- une barrière (48) dans la lumière (58) de mise en place de cathéter, au niveau ou proche de l'extrémité proximale (44) du corps (42A) pour permettre une obturation sélective de la lumière (58) mise en place de cathéter; et
 5 une région de transfert thermique située en position distale, associée au corps (42A) et communiquant avec les lumières (60, 62) d'arrivée et de retour de liquide de refroidissement.
2. Cathéter selon la revendication 1, comprenant :
- au moins un capteur de température (50) monté sur le corps (42A) au niveau ou proche de l'extrémité distale (46) pour générer un signal de température.
3. Cathéter selon la revendication 1 ou la revendication 2, dans lequel le cathéter est un cathéter d'échange thermique (20), comprenant :
- un corps de cathéter (102) définissant au moins une lumière (28) d'arrivée de fluide de refroidissement, une lumière (34) de retour de fluide de refroidissement, et une lumière (38) de circulation d'air;
 25 au moins une première membrane de refroidissement (22) définissant une chambre communiquant avec les lumières (28, 34) d'arrivée et de retour de fluide de refroidissement; et
 30 au moins un premier ballon gonflable (24) disposé dans la chambre et pouvant être déplacé de manière sélective entre une configuration gonflée, dans laquelle le ballon gonflable (24) provoque l'écoulement du fluide de refroidissement à proximité d'une surface extérieure de la membrane de refroidissement (22) pour réaliser ainsi un échange thermique relativement plus élevée avec le sang, et une configuration dégonflée, dans laquelle le fluide de refroidissement a tendance à s'écouler à travers la membrane de refroidissement (22), avec des caractéristiques d'écoulement laminaire, plus près du corps du cathéter (20) que de la surface extérieure de la membrane de refroidissement (22).
 45
4. Cathéter selon l'une quelconque des revendications précédentes, qui est un cathéter multi-lumières (18, 54), et qui comprend, en outre :
- 50 au moins une membrane ou ballon (22, 82) d'échange thermique situé à une position distale sur le cathéter (18, 54) et communiquant avec au moins une lumière (28, 60) de fluide de refroidissement du cathéter (18, 54)
 55 un système d'échange thermique (12, 78) communiquant avec au moins la lumière (28, 60) de fluide de refroidissement, un fluide de refroidissement étant mis en circulation entre le système d'échange thermique et la membrane ou ballon (22, 82) pour réaliser un échange thermique avec un patient ; et
 au moins un élément de retenue (18a) pouvant entrer en prise avec le cathéter (18, 54) pour retenir le cathéter (18, 54) sur un patient.
5. Cathéter selon la revendication 4, comprenant, en outre, un système veineux central (19) communiquant avec au moins une lumière du cathéter (18, 54).
6. Cathéter selon l'une quelconque des revendications précédentes, qui est un cathéter multi-lumières (18, 54), et qui comprend, en outre :
- au moins une membrane ou ballon (22, 82) d'échange thermique situé à une position distale sur le cathéter (18, 54) et communiquant avec au moins une lumière (28, 60) de fluide de refroidissement du cathéter (18, 54) ;
 un système d'échange thermique (12, 78) communiquant avec au moins la lumière (28, 60) de fluide de refroidissement, un fluide de refroidissement étant mis en circulation entre le système d'échange thermique et la membrane ou ballon (22, 82) pour réaliser un échange thermique avec un patient ; et
 un système veineux central (19) communiquant avec au moins une lumière du cathéter (54).
7. Cathéter selon l'une quelconque des revendications précédentes, comprenant, en outre, au moins un élément de retenue (18a) pouvant entrer en prise avec le cathéter (18, 54) pour retenir le cathéter (18, 54) sur un patient.

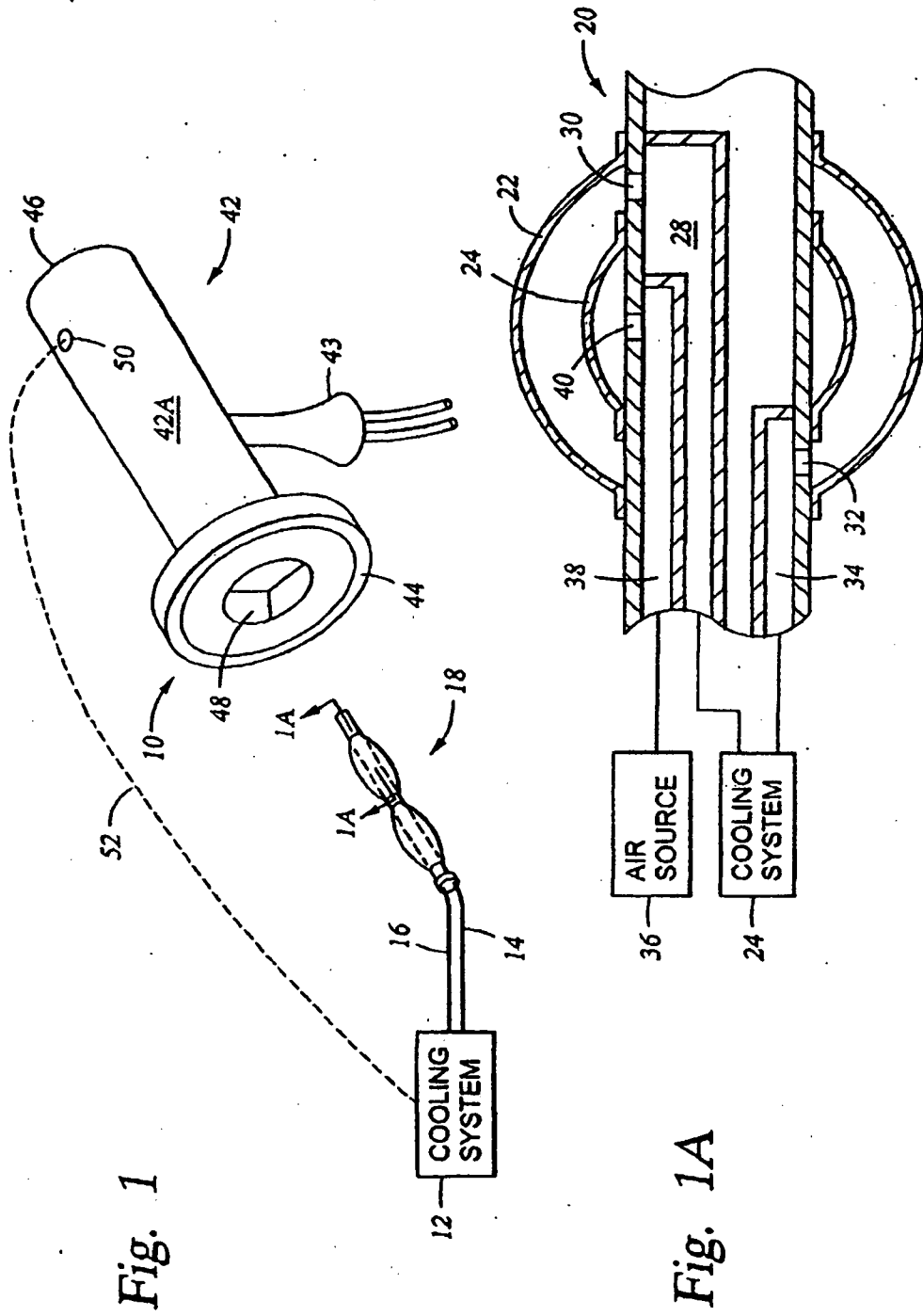

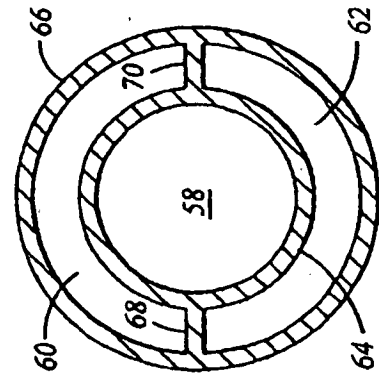
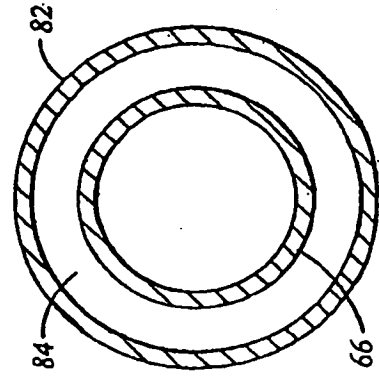
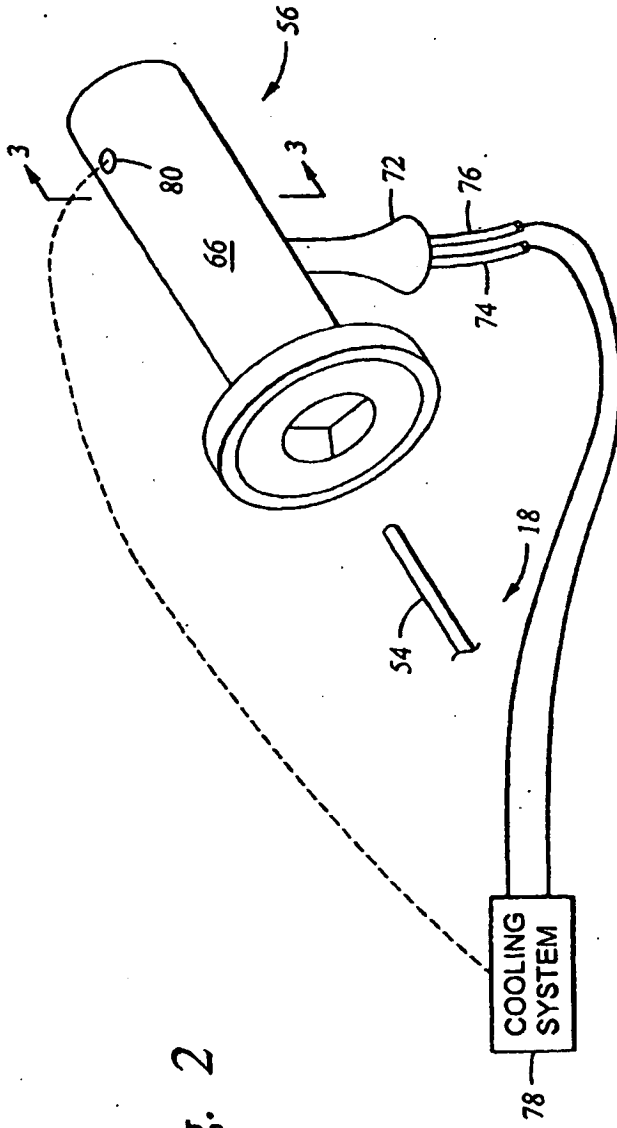

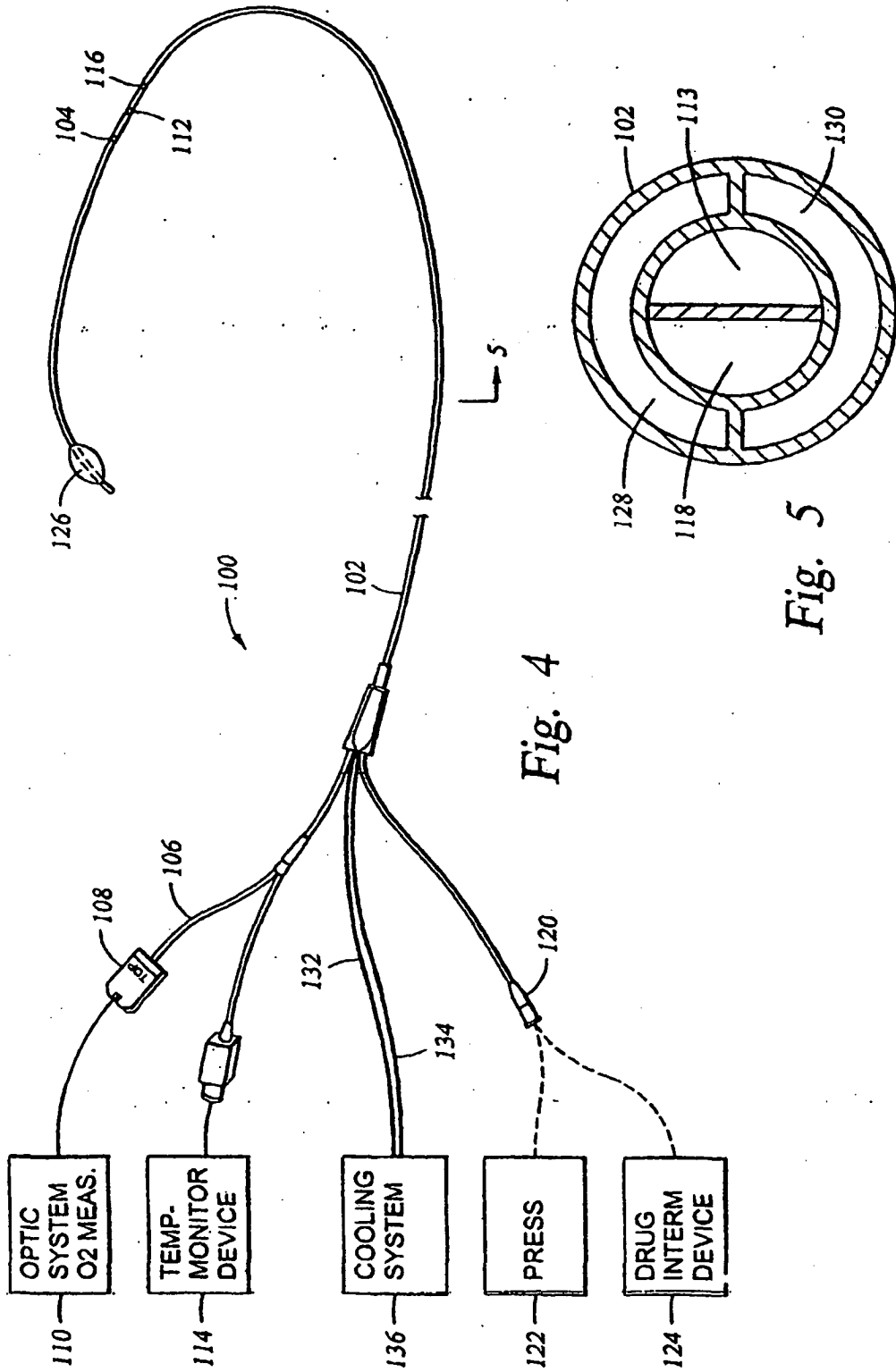
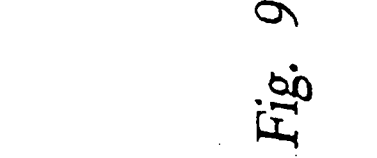
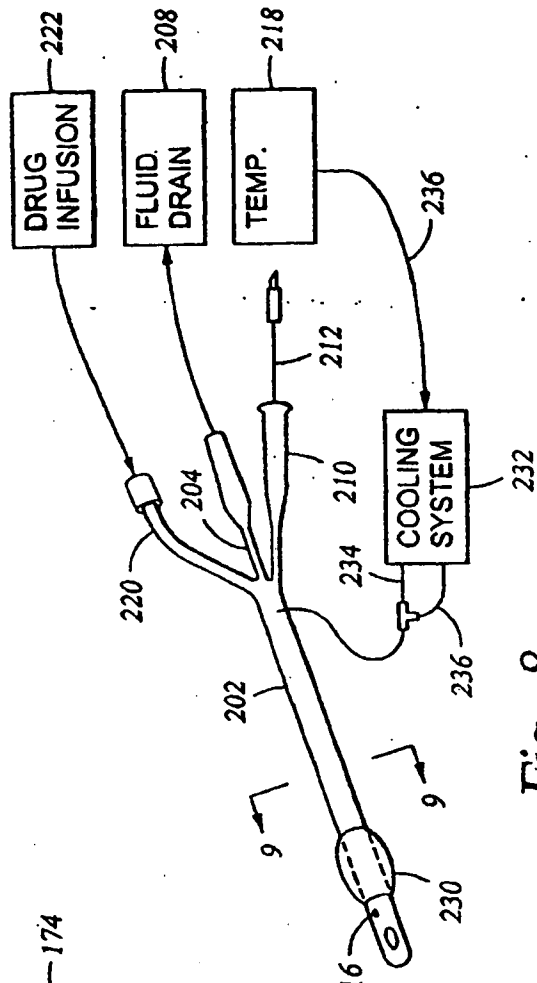
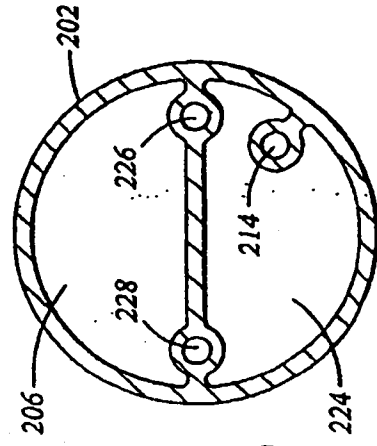
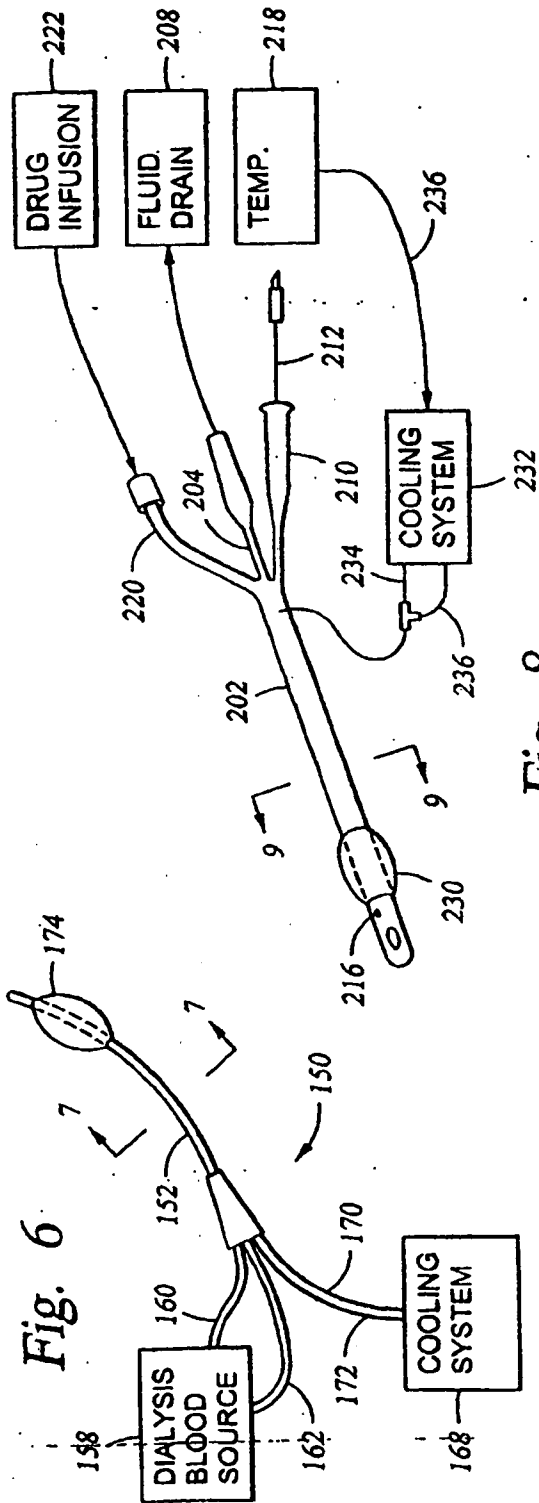

Fig. 4

Fig. 5



REFERENCES CITED IN THE DESCRIPTION

This list of references cited by the applicant is for the reader's convenience only. It does not form part of the European patent document. Even though great care has been taken in compiling the references, errors or omissions cannot be excluded and the EPO disclaims all liability in this regard.

Patent documents cited in the description

- US 6126684 A [0003]
- US 09063984 B [0003]
- US 6338727 A [0005]
- US 13381398 A [0005]
- US 25310999 A [0006] [0016]
- WO 0048670 A [0006]
- US 6146411 A [0015]
- US 22089798 A [0015]
- US 6019783 A [0015]
- US 26095099 A [0015]
- US 4578063 A [0016]
- US 5693032 A [0016]
- US 5192274 A [0016]
- US 3677250 A [0016]
- US 30561399 A [0017]
- WO 0066053 A [0017]
- US 3995623 A [0023]

专利名称(译)	中心静脉导管具有热交换特性		
公开(公告)号	EP1204368B1	公开(公告)日	2008-08-13
申请号	EP2000968972	申请日	2000-08-16
[标]申请(专利权)人(译)	ALSIUS		
申请(专利权)人(译)	ALSIUS CORPORATION		
当前申请(专利权)人(译)	ALSIUS CORPORATION		
[标]发明人	SHIMADA LYNN M WORTHEN WILLIAM J EVANS SCOTT M LUO XIA PECOR ROBERT WALKER BLAIR		
发明人	SHIMADA, LYNN, M. WORTHEN, WILLIAM, J. EVANS, SCOTT, M. LUO, XIA PECOR, ROBERT WALKER, BLAIR		
IPC分类号	A61B5/00 A61M25/00 A61F7/12 A61B17/00 A61B17/34 A61B18/00 A61F2/958 A61F7/10 A61M1/36 A61M5/44 A61M25/06 A61M25/14		
CPC分类号	A61F7/123 A61B17/3415 A61B17/3417 A61B17/3421 A61B17/3462 A61B2017/00084 A61B2018 /00011 A61B2018/00023 A61F7/10 A61F7/12 A61F2007/126 A61M1/369 A61M5/44 A61M25/00 A61M25/0028 A61M25/0032 A61M25/0662 A61M25/1011 A61M2025/0031 A61M2025/0036 A61M2025 /1013 A61M2205/36		
优先权	09/376524 1999-08-18 US		
其他公开文献	EP1204368A4 EP1204368A1		
外部链接	Espacenet		

摘要(译)

用于中心静脉导管 (54) 的导引器护套 (42) 包括护套主体 (56) 和安装在主体 (56) 上的远端的温度传感器 (80)。

