



- (51) International Patent Classification:
A61B 18/04 (2006.01)
- (21) International Application Number:
PCT/US2012/040639
- (22) International Filing Date:
3 June 2012 (03.06.2012)
- (25) Filing Language: English
- (26) Publication Language: English
- (30) Priority Data:
61/493,344 3 June 2011 (03.06.2011) US
- (72) Inventor; and
- (71) Applicant : SHARMA, Virender, K. [US/US]; 6531 North 60th Street, Paradise Valley, AZ 85253 (US).
- (74) Agent: ANSARI, Hazim; Novel IP, 191 West Second Street, Santa Ana, CA 92701 (US).
- (81) Designated States (unless otherwise indicated, for every kind of national protection available): AE, AG, AL, AM, AO, AT, AU, AZ, BA, BB, BG, BH, BR, BW, BY, BZ,

CA, CH, CL, CN, CO, CR, CU, CZ, DE, DK, DM, DO, DZ, EC, EE, EG, ES, FI, GB, GD, GE, GH, GM, GT, HN, HR, HU, ID, IL, IN, IS, JP, KE, KG, KM, KN, KP, KR, KZ, LA, LC, LK, LR, LS, LT, LU, LY, MA, MD, ME, MG, MK, MN, MW, MX, MY, MZ, NA, NG, NI, NO, NZ, OM, PE, PG, PH, PL, PT, QA, RO, RS, RU, RW, SC, SD, SE, SG, SK, SL, SM, ST, SV, SY, TH, TJ, TM, TN, TR, TT, TZ, UA, UG, US, UZ, VC, VN, ZA, ZM, ZW.

- (84) Designated States (unless otherwise indicated, for every kind of regional protection available): ARIPO (BW, GH, GM, KE, LR, LS, MW, MZ, NA, RW, SD, SL, SZ, TZ, UG, ZM, ZW), Eurasian (AM, AZ, BY, KG, KZ, RU, TJ, TM), European (AL, AT, BE, BG, CH, CY, CZ, DE, DK, EE, ES, FI, FR, GB, GR, HR, HU, IE, IS, IT, LT, LU, LV, MC, MK, MT, NL, NO, PL, PT, RO, RS, SE, SI, SK, SM, TR), OAPI (BF, BJ, CF, CG, CI, CM, GA, GN, GQ, GW, ML, MR, NE, SN, TD, TG).

Published:
— without international search report and to be republished upon receipt of that report (Rule 48.2(g))



WO 2012/167213 A2

(54) Title: METHOD AND APPARATUS FOR TISSUE ABLATION

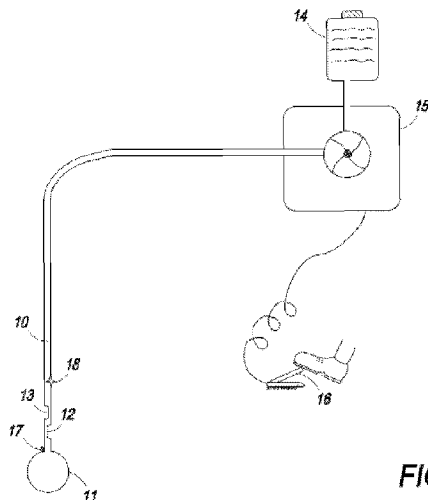

FIG. 1

(57) Abstract: The present application discloses devices that ablate human tissue. The device comprises a catheter with a shaft through which an ablative agent can travel, a liquid reservoir and a heating component, which may comprise a length of coiled tubing contained within a heating element, wherein activation of said heating element causes said coiled tubing to increase from a first temperature to a second temperature and wherein the increase causes a conversion of liquid within the coiled tubing to vapor, a reusable cord connecting the outlet of the reservoir to the inlet of the heating component, and a single use cord connecting a pressure-resistant inlet port of a vapor based ablation device to the outlet of the heating component.

METHOD AND APPARATUS FOR TISSUE ABLATION

CROSS-REFERENCE TO RELATED APPLICATIONS

5 The present application also relies on United States Provisional Patent Application Number 61/493,344, entitled "Method and Apparatus for Tissue Ablation", filed on June 3, 2011, and assigned to the applicant of the present invention, for priority, which is herein incorporated by reference in its entirety.

FIELD OF THE INVENTION

10 The present invention relates to medical apparatus and procedures. More particularly, the present invention relates to a device for ablation of tissue comprising a centering or positioning attachment in order to position the device at a consistent distance from the tissue to be ablated.

BACKGROUND OF THE INVENTION

15 Colon polyps affect almost 25% of the population over the age of 50. While most polyps are detected on colonoscopy and easily removed using a snare, flat sessile polyps are hard to remove using the snare technique and carry a high risk of complications, such as bleeding and perforation. Recently, with improvement in imaging techniques, more flat
20 polyps are being detected. Endoscopically unresectable polyps require surgical removal. Most colon cancer arises from colon polyps and, safe and complete resection of these polyps is imperative for the prevention of colon cancer.

Barrett's esophagus is a precancerous condition effecting 10-14% of the US population with gastro esophageal reflux disease (GERD) and is the proven precursor lesion
25 of esophageal adenocarcinoma, the fastest rising cancer in the developed nations. The incidence of the cancer has risen over 6 fold in the last 2 decades and mortality has risen by 7 fold. The 5-year mortality from esophageal cancer is 85%. Ablation of Barrett's epithelium has shown to prevent its progression to esophageal cancer.

Dysfunctional uterine bleeding (DUB), or menorrhagia, affects 30% of women in
30 reproductive age. The associated symptoms have considerable impact on a woman's health and quality of life. The condition is typically treated with endometrial ablation or a hysterectomy. The rates of surgical intervention in these women are high. Almost 30% of women in the US will undergo hysterectomy by the age of 60, with menorrhagia or DUB being the cause for surgery in 50-70% of these women. Endometrial ablation techniques have

been FDA approved for women with abnormal uterine bleeding and with intramural fibroids less than 2 cm. The presence of submucosal uterine fibroids and a large uterus size have been shown to decrease the efficacy of standard endometrial ablation. Of the five FDA approved global ablation devices (namely, Thermachoice, hydrothermal ablation, Novasure, Her
5 Option, and microwave ablation) only microwave ablation (MEA) has been approved for use where the submucosal fibroids are less than 3 cm and are not occluding the endometrial cavity and, additionally, for large uteri up to 14 cm.

The known ablation treatments for Barrett's esophagus include laser treatment (Ertan et al, Am. J. Gastro., 90:2201-2203 [1995]), ultrasonic ablation (Bremner et al, Gastro. Endo.,
10 43:6 [1996]), photodynamic therapy (PDT) using photo-sensitizer drugs (Overholt et al, Semin. Surg. Oncol., 1 :372-376 (1995), multipolar electrocoagulation, such as by use of a bicap probe (Sampliner et al.), argon plasma coagulation (APC;), radiofrequency ablation (Sharma et al. Gastrointest Endosc) and cryoablation (Johnston et al. Gastrointest Endosc). The treatments are delivered with the aid of an endoscope and devices passed through the
15 channel of the endoscope or alongside the endoscope.

Conventional techniques have inherent limitations, however, and have not found widespread clinical applications. First, most of the hand held ablation devices (bicap probe, APC, cryoablation) are point and shoot devices that create small foci of ablation. This ablation mechanism is operator dependent, cumbersome and time consuming. Second,
20 because the target tissue is moving due to patient movement, respiration movement, normal peristalsis and vascular pulsations, the depth of ablation of the target tissue is inconsistent and results in a non-uniform ablation. Superficial ablation results in incomplete ablation with residual neoplastic tissue left behind. Deeper ablation results in complications such as bleeding, stricture formation and perforation. All of these limitations and complications have
25 been reported with conventional devices.

For example, radiofrequency ablation uses a rigid bipolar balloon based electrode and radiofrequency thermal energy. The thermal energy is delivered by direct contact of the electrode with the diseased Barrett's epithelium allowing for a relatively uniform, large area ablation. However, the rigid electrode does not accommodate for variations in esophageal
30 size and is ineffective in ablating lesions within a tortuous esophagus, proximal esophageal lesions as an esophagus narrows toward the top, and lesions in the esophagus at the gastroesophageal junction due to changes in the esophageal diameter. Nodular disease in Barrett's esophagus also cannot be treated using the rigid bipolar RF electrode. Due to its size and rigidity, the electrode cannot be passed through the scope. In addition, sticking of

sloughed tissue to the electrode impedes delivery of radiofrequency energy resulting in incomplete ablation. The electrode size is limited to 3 cm, thus requiring repeat applications to treat larger lengths of Barrett's esophagus.

5 Photodynamic therapy (PDT) is a two part procedure that involves injecting a photo-sensitizer that is absorbed and retained by the neoplastic and pre-neoplastic tissue. The tissue is then exposed to a selected wavelength of light which activates the photo-sensitizer and results in tissue destruction. PDT is associated with complications such as stricture formation and photo-sensitivity which has limited its use to the most advanced stages of the disease. In addition, patchy uptake of the photosensitizer results in incomplete ablation and residual
10 neoplastic tissue.

Cryoablation of the esophageal tissues via direct contact with liquid nitrogen has been studied in both animal models and humans (Rodgers et al, *Cryobiology*, 22:86-92 (1985); Rodgers et al, *Ann. Thorac. Surg.* 55:52-7 [1983]) and has been used to treat Barrett's esophagus (Johnston et al. *Gastrointest Endosc*) and early esophageal cancer (Grana et al, *Int. Surg.*, 66:295 [1981]). A spray catheter that directly sprays liquid N₂ or CO₂ (cryoablation) or argon (APC) to ablate Barrett's tissue in the esophagus has been described. These techniques suffer the shortcoming of the traditional hand-held devices. Treatment using this probe is cumbersome and requires operator control under direct endoscopic visualization. Continuous movement in the esophagus due to respiration or cardiac or aortic pulsations or
20 movement causes an uneven distribution of the ablative agent and results in non-uniform and/or incomplete ablation. Close or direct contact of the catheter to the surface epithelium may cause deeper tissue injury, resulting in perforation, bleeding or stricture formation. Too distant a placement of the catheter due to esophageal movement will result in incomplete Barrett's ablation, requiring multiple treatment sessions or buried lesions with a continued
25 risk of esophageal cancer. Expansion of cryogenic gas in the esophagus results in uncontrolled retching which may result in esophageal tear or perforation requiring continued suctioning of cryogen.

Colon polyps are usually resected using snare resection with or without the use of monopolar cautery. Flat polyps or residual polyps after snare resection have been treated with
30 argon plasma coagulation or laser treatment. Both of these treatments are inadequate due to the previously mentioned limitations. Hence, most large flat polyps undergo surgical resection due to high risk of bleeding, perforation and residual disease using traditional endoscopic resection or ablation techniques.

Most of the conventional balloon catheters traditionally used for tissue ablation either heat or cool the balloon itself or a heating element such as radio frequency (RF) coils mounted on the balloon. This requires direct contact of the balloon catheter with the ablated surface. When the balloon catheter is deflated, the epithelium sticks to the catheter and sloughs off, thereby causing bleeding. Blood can interfere with the delivery of energy, and therefore acts as an energy sink. In addition, reapplication of energy will result in deeper burn in the area where superficial lining has sloughed. Further, balloon catheters cannot be employed for treatment in non-cylindrical organs, like the uterus or sinuses, and also do not provide non-circumferential or focal ablation in a hollow organ. Additionally, if used with cryogens as ablative agents, which expand exponentially upon being heated, balloon catheters may result in a closed cavity and trap the escape of cryogen, resulting in complications such as perforations and tears.

Accordingly, there is a need in the art for an improved method and system for delivering ablative agents to a tissue surface, for providing a consistent, controlled, and uniform ablation of the target tissue, and for minimizing the adverse side effects of introducing ablative agents into a patient.

SUMMARY OF THE INVENTION

In one embodiment, the present specification discloses a device to be used in conjunction with a tissue ablation system, comprising: a handle with a pressure-resistant port on its distal end, a flow channel through which an ablative agent can travel, and one or more connection ports on its proximal end for the inlet of said ablative agent and for an RF feed; an insulated catheter that attaches to said pressure-resistant port of said snare handle, containing a shaft through which an ablative agent can travel and one or more ports along its length for the release of said ablative agent; and one or more positioning elements attached to said catheter shaft at one or more separate positions, wherein said positioning element(s) is configured to position said catheter at a predefined distance from the tissue to be ablated.

Optionally, the handle has one pressure-resistant port for the attachment of both an ablative agent inlet and an RF feed. The handle has one separate pressure-resistant port for the attachment of an ablative agent inlet and one separate port for the attachment of an RF feed or an electrical feed.

In another embodiment, the present specification discloses a device to be used in conjunction with a tissue ablation system, comprising: a handle with a pressure-resistant port on its distal end, a flow channel passing through said handle which is continuous with a pre-

attached cord through which an ablative agent can travel, and a connection port on its proximal end for an RF feed or an electrical field; an insulated catheter that attaches to said pressure-resistant port of said handle, containing a shaft through which an ablative agent can travel and one or more ports along its length for the release of said ablative agent; and one or more positioning elements attached to said catheter shaft at one or more separate positions, wherein said positioning element(s) is configured to position said catheter at a predefined distance from the tissue to be ablated. Optionally, the distal end of said catheter is designed to puncture the target.

In another embodiment, the present specification discloses a device to be used in conjunction with a tissue ablation system, comprising: an esophageal probe with a pressure-resistant port on its distal end, a flow channel through which an ablative agent can travel, and one or more connection ports on its proximal end for the inlet of said ablative agent and for an RF feed or an electrical feed; an insulated catheter that attaches to said pressure-resistant port of said esophageal probe, containing a shaft through which an ablative agent can travel and one or more ports along its length for the release of said ablative agent; and one or more inflatable positioning balloons at either end of said catheter positioned beyond said one or more ports, wherein said positioning balloons are configured to position said catheter at a predefined distance from the tissue to be ablated.

Optionally, the catheter is dual lumen, wherein a first lumen facilitates the transfer of ablative agent and a second lumen contains an electrode for RF ablation. The catheter has differential insulation along its length.

The present specification is also directed toward a tissue ablation device, comprising: a liquid reservoir, wherein said reservoir includes an outlet connector that can resist at least 1 atm of pressure for the attachment of a reusable cord; a heating component comprising: a length of coiled tubing contained within a heating element, wherein activation of said heating element causes said coiled tubing to increase from a first temperature to a second temperature and wherein said increase causes a conversion of liquid within said coiled tubing to vapor; and an inlet connected to said coiled tubing; an outlet connected to said coiled tubing; and at least one pressure-resistant connection attached to the inlet and/or outlet; a cord connecting the outlet of said reservoir to the inlet of the heating component; a single use cord connecting a pressure-resistant inlet port of a vapor based ablation device to the outlet of said heating component.

In one embodiment, the liquid reservoir is integrated within an operating room equipment generator. In one embodiment, the liquid is water and the vapor is steam.

In one embodiment, the pressure-resistant connections are luer lock connections. In one embodiment, the coiled tubing is copper.

In one embodiment, the tissue ablation device further comprises a foot pedal, wherein only when said foot pedal is pressed, vapor is generated and passed into said single use cord. In another embodiment, only when pressure is removed from said foot pedal, vapor is generated and passed into said single use cord.

In another embodiment, the present specification discloses a vapor ablation system used for supplying vapor to an ablation device, comprising; a single use sterile fluid container with attached compressible tubing used to connect the fluid source to a heating unit in the handle of a vapor ablation catheter. The tubing passes through a pump that delivers the fluid into the heating unit at a predetermined speed. There is present a mechanism such as a unidirectional valve between the fluid container and the heating unit to prevent the backflow of vapor from the heating unit. The heating unit is connected to the ablation catheter to deliver the vapor from the heating unit to the ablation site. The flow of vapor is controlled by a microprocessor. The microprocessor uses a pre-programmed algorithm in an open-loop system or uses information from one or more sensors incorporated in the ablation system in a closed-loop system or both to control delivery of vapor.

In one embodiment the handle of the ablation device is made of a thermally insulating material to prevent thermal injury to the operator. The heating unit is enclosed in the handle. The handle locks into the channel of an endoscope after the catheter is passed through the channel of the endoscope. The operator can then manipulate the catheter by holding the insulated handle or by manipulating the catheter proximal to the insulating handle.

The present specification is also directed toward a vapor ablation system comprising: a container with a sterile liquid therein; a pump in fluid communication with said container; a first filter disposed between and in fluid communication with said container and said pump; a heating component in fluid communication with said pump; a valve disposed between and in fluid communication with said pump and heating container; a catheter in fluid communication with said heating component, said catheter comprising at least one opening at its operational end; and, a microprocessor in operable communication with said pump and said heating component, wherein said microprocessor controls the pump to control a flow rate of the liquid from said container, through said first filter, through said pump, and into said heating component, wherein said liquid is converted into vapor via the transfer of heat from said heating component to said fluid, wherein said conversion of said fluid into said vapor results in a volume expansion and a rise in pressure where said rise in pressure forces said

vapor into said catheter and out said at least one opening, and wherein a temperature of said heating component is controlled by said microprocessor.

In one embodiment, the vapor ablation system further comprises at least one sensor on said catheter, wherein information obtained by said sensor is transmitted to said microprocessor, and wherein said information is used by said microprocessor to regulate said pump and said heating component and thereby regulate vapor flow. In one embodiment, the at least one sensor includes one or more of a temperature sensor, flow sensor, or pressure sensor.

In one embodiment, the vapor ablation system further comprises a screw cap on said liquid container and a puncture needle on said first filter, wherein said screw cap is punctured by said puncture needle to provide fluid communication between said container and said first filter.

In one embodiment, the liquid container and catheter are disposable and configured for a single use.

In one embodiment, the fluid container, first filter, pump, heating component, and catheter are connected by sterile tubing and the connections between said pump and said heating component and said heating component and said catheter are pressure resistant.

The present specification is also directed toward a tissue ablation system comprising: a catheter with a proximal end and a distal end and a lumen therebetween, said catheter comprising: a handle proximate the proximal end of said catheter and housing a fluid heating chamber and a heating element enveloping said chamber, a wire extending distally from said heating element and leading to a controller; an insulating sheath extending and covering the length of said catheter and disposed between said handle and said heating element at said distal end of said catheter; and, at least one opening proximate the distal end of said catheter for the passage of vapor; and, a controller operably connected to said heating element via said wire, wherein said controller is capable of modulating energy supplied to said heating element and further wherein said controller is capable of adjusting a flow rate of liquid supplied to said catheter; wherein liquid is supplied to said heating chamber and then converted to vapor within said heating chamber by a transfer of heat from said heating element to said chamber, wherein said conversion of said liquid to vapor results in a volume expansion and a rise in pressure within said catheter, and wherein said rise in pressure pushes said vapor through said catheter and out said at least one opening.

In one embodiment, the tissue ablation system further comprises a pressure resistant fitting attached to the fluid supply and a one-way valve in said pressure resistant fitting to prevent a backflow of vapor into the fluid supply.

In one embodiment, the tissue ablation system further comprises at least one sensor on said catheter, wherein information obtained by said sensor is transmitted to said microprocessor, and wherein said information is used by said microprocessor to regulate said pump and said heating component and thereby regulate vapor flow.

In one embodiment, the tissue ablation system further comprises a metal frame within said catheter, wherein said metal frame is in thermal contact with said heating chamber and conducts heat to said catheter lumen, thereby preventing condensation of said vapor. In various embodiments, the metal frame comprises a metal skeleton with outwardly extending fins at regularly spaced intervals, a metal spiral, or a metal mesh and the metal frame comprises at least one of copper, stainless steel, or another ferric material.

In one embodiment, the heating element comprises a heating block, wherein said heating block is supplied power by said controller.

In various embodiments, the heating element uses one of magnetic induction, microwave, high intensity focused ultrasound, or infrared energy to heat said heating chamber and the fluid therein.

BRIEF DESCRIPTION OF THE DRAWINGS

These and other features and advantages of the present invention will be further appreciated, as they become better understood by reference to the detailed description when considered in connection with the accompanying drawings, wherein:

5 FIG. 1 illustrates an ablation device, in accordance with an embodiment of the present invention;

 FIG. 2A illustrates a longitudinal section of an ablation device with ports distributed thereon;

 FIG. 2B illustrates a cross section of a port on the ablation device, in accordance with
10 an embodiment of the present invention;

 FIG. 2C illustrates a cross section of a port on the ablation device, in accordance with another embodiment of the present invention;

 FIG. 2D illustrates a catheter of the ablation device, in accordance with an embodiment of the present invention;

FIG. 2E illustrates an ablation device in the form of a catheter extending from a conventional snare handle, in accordance with an embodiment of the present invention;

FIG. 2F illustrates a cross section of an ablation device in the form of a catheter extending from a conventional snare handle with a pre-attached cord, in accordance with another embodiment of the present invention;

FIG. 2G illustrates an ablation device in the form of a catheter extending from a conventional esophageal probe, in accordance with an embodiment of the present invention;

FIG. 3A illustrates the ablation device placed in an upper gastrointestinal tract with Barrett's esophagus to selectively ablate the Barrett's tissue, in accordance with an embodiment of the present invention;

FIG. 3B illustrates the ablation device placed in an upper gastrointestinal tract with Barrett's esophagus to selectively ablate the Barrett's tissue, in accordance with another embodiment of the present invention;

FIG. 3C is a flowchart illustrating the basic procedural steps for using the ablation device, in accordance with an embodiment of the present invention;

FIG. 4A illustrates the ablation device placed in a colon to ablate a flat colon polyp, in accordance with an embodiment of the present invention;

FIG. 4B illustrates the ablation device placed in a colon to ablate a flat colon polyp, in accordance with another embodiment of the present invention;

FIG. 5A illustrates the ablation device with a coaxial catheter design, in accordance with an embodiment of the present invention;

FIG. 5B illustrates a partially deployed positioning device, in accordance with an embodiment of the present invention;

FIG. 5C illustrates a completely deployed positioning device, in accordance with an embodiment of the present invention;

FIG. 5D illustrates the ablation device with a conical positioning element, in accordance with an embodiment of the present invention;

FIG. 5E illustrates the ablation device with a disc shaped positioning element, in accordance with an embodiment of the present invention;

FIG. 6 illustrates an upper gastrointestinal tract with a bleeding vascular lesion being treated by the ablation device, in accordance with an embodiment of the present invention;

FIG. 7 illustrates endometrial ablation being performed in a female uterus by using the ablation device, in accordance with an embodiment of the present invention;

FIG. 8 illustrates sinus ablation being performed in a nasal passage by using the ablation device, in accordance with an embodiment of the present invention;

FIG. 9 illustrates bronchial and bullous ablation being performed in a pulmonary system by using the ablation device, in accordance with an embodiment of the present invention;

FIG. 10 illustrates prostate ablation being performed on an enlarged prostate in a male urinary system by using the device, in accordance with an embodiment of the present invention;

FIG. 11 illustrates fibroid ablation being performed in a female uterus by using the ablation device, in accordance with an embodiment of the present invention;

FIG. 12 illustrates a vapor delivery system using an RF heater for supplying vapor to the ablation device, in accordance with an embodiment of the present invention;

FIG. 13 illustrates a vapor delivery system using a resistive heater for supplying vapor to the ablation device, in accordance with an embodiment of the present invention;

FIG. 14 illustrates a vapor delivery system using a heating coil for supplying vapor to the ablation device, in accordance with an embodiment of the present invention;

FIG. 15 illustrates the heating component and coiled tubing of the heating coil vapor delivery system of FIG. 14, in accordance with an embodiment of the present invention;

FIG. 16A illustrates the unassembled interface connection between the ablation device and the single use cord of the heating coil vapor delivery system of FIG. 14, in accordance with an embodiment of the present invention;

FIG. 16B illustrates the assembled interface connection between the ablation device and the single use cord of the heating coil vapor delivery system of FIG. 14, in accordance with an embodiment of the present invention;

FIG. 17 illustrates a vapor ablation system using a heater or heat exchange unit for supplying vapor to the ablation device, in accordance with another embodiment of the present invention;

FIG. 18 illustrates the fluid container, filter member, and pump of the vapor ablation system of FIG. 17;

FIG. 19 illustrates a first view of the fluid container, filter member, pump, heater or heat exchange unit, and microcontroller of the vapor ablation system of FIG. 17;

FIG. 20 illustrates a second view of the fluid container, filter member, pump, heater or heat exchange unit, and microcontroller of the vapor ablation system of FIG. 17;

FIG. 21 illustrates the unassembled filter member of the vapor ablation system of FIG. 17, depicting the filter positioned within;

FIG. 22 illustrates one embodiment of the microcontroller of the vapor ablation system of FIG. 17;

5 FIG. 23 illustrates one embodiment of a catheter assembly for use with the vapor ablation system of FIG. 17;

FIG. 24 illustrates one embodiment of a heat exchange unit for use with the vapor ablation system of FIG. 17;

10 FIG. 25 illustrates another embodiment of a heat exchange unit for use with the vapor ablation system of the present invention;

FIG. 26 illustrates the use of induction heating to heat a chamber;

FIG. 27A illustrates one embodiment of a coil used with induction heating in the vapor ablation system of the present invention;

15 FIG. 27B illustrates one embodiment of a catheter handle used with induction heating in the vapor ablation system of the present invention;

FIG. 28A is a front view cross sectional diagram illustrating one embodiment of a catheter used with induction heating in the vapor ablation system of the present invention;

20 FIG. 28B is a longitudinal view cross sectional diagram illustrating one embodiment of a catheter used with induction heating in the vapor ablation system of the present invention;

FIG. 28C is a longitudinal view cross sectional diagram illustrating another embodiment of a catheter with a metal spiral used with induction heating in the vapor ablation system of the present invention;

25 FIG. 28D is a longitudinal view cross sectional diagram illustrating another embodiment of a catheter with a mesh used with induction heating in the vapor ablation system of the present invention; and,

FIG. 29 illustrates one embodiment of a heating unit using microwaves to convert fluid to vapor in the vapor ablation system of the present invention.

30 **DETAILED DESCRIPTION OF THE INVENTION**

The present invention is directed toward an ablation device comprising a catheter with one or more centering or positioning attachments at one or more ends of the catheter to affix the catheter and its infusion port at a fixed distance from the ablative tissue which is not affected by the movements of the organ. The arrangement of one or more spray ports allows

for uniform spray of the ablative agent producing a uniform ablation of a large area, such as encountered in Barrett's esophagus. The flow of ablative agent is controlled by the microprocessor and depends upon one or more of the length or area of tissue to be ablated, type and depth of tissue to be ablated, and distance of the infusion port from or in the tissue to be ablated.

The present invention is also directed toward a device to be used in conjunction with a tissue ablation system, comprising: a handle with a pressure-resistant port on its distal end, a flow channel through which an ablative agent can travel, and one or more connection ports on its proximal end for the inlet of said ablative agent and for an RF feed or an electrical feed; an insulated catheter that attaches to said pressure-resistant port of said handle, containing a shaft through which an ablative agent can travel and one or more ports along its length for the release of said ablative agent; and, one or more positioning elements attached to said catheter shaft at one or more separate positions, wherein said positioning element(s) is configured to position said catheter at a predefined distance from or in the tissue to be ablated.

In one embodiment, the handle has one pressure-resistant port for the attachment of both an ablative agent inlet and an RF feed. In another embodiment, the handle has one separate pressure-resistant port for the attachment of an ablative agent inlet and one separate port for the attachment of an RF feed or an electrical feed.

The present invention is also directed toward a device to be used in conjunction with a tissue ablation system, comprising: a handle with a pressure-resistant port on its distal end, a flow channel passing through said handle which is continuous with a pre-attached cord through which an ablative agent can travel, and a connection port on its proximal end for an RF feed or an electrical feed; an insulated catheter that attaches to said pressure-resistant port of said handle, containing a shaft through which an ablative agent can travel and one or more ports along its length for the release of said ablative agent; and, one or more positioning elements attached to said catheter shaft at one or more separate positions, wherein said positioning element(s) is configured to position said catheter at a predefined distance from or in the tissue to be ablated. In one embodiment, the distal end of said catheter is designed to puncture the target tissue to deliver ablative agent to the correct depth and location.

The present invention is also directed toward a device to be used in conjunction with a tissue ablation system, comprising: an esophageal probe with a pressure-resistant port on its distal end, a flow channel through which an ablative agent can travel, and one or more connection ports on its proximal end for the inlet of said ablative agent and for an RF feed; an insulated catheter that attaches to said pressure-resistant port of said esophageal probe,

containing a shaft through which an ablative agent can travel and one or more ports along its length for the release of said ablative agent; and, one or more inflatable positioning balloons at either end of said catheter positioned beyond said one or more ports, wherein said positioning balloons are configured to position said catheter at a predefined distance from the tissue to be ablated.

In one embodiment, the catheter is dual lumen, wherein a first lumen facilitates the transfer of ablative agent and a second lumen contains an electrode for RF ablation.

In one embodiment, the catheter has differential insulation along its length.

The present invention is also directed toward a vapor delivery system used for supplying vapor to an ablation device, comprising: a liquid reservoir, wherein said reservoir includes a pressure-resistant outlet connector for the attachment of a reusable cord; a reusable cord connecting the outlet of said reservoir to the inlet of a heating component; a powered heating component containing a length of coiled tubing within for the conversion of liquid to vapor and pressure-resistant connections on both the inlet and outlet ends of said heating component; and, a single use cord connecting a pressure-resistant inlet port of a vapor based ablation device to the outlet of said heating component.

In one embodiment, the liquid reservoir is integrated within an operating room equipment generator.

In one embodiment, the liquid is water and resultant said vapor is steam.

In one embodiment, the pressure-resistant connections are of a luer lock type.

In one embodiment, the coiled tubing is copper.

In one embodiment, the vapor delivery system used for supplying vapor to an ablation device further comprises a foot pedal used by the operator to deliver more vapor to the ablation device.

“Treat,” “treatment,” and variations thereof refer to any reduction in the extent, frequency, or severity of one or more symptoms or signs associated with a condition.

“Duration” and variations thereof refer to the time course of a prescribed treatment, from initiation to conclusion, whether the treatment is concluded because the condition is resolved or the treatment is suspended for any reason. Over the duration of treatment, a plurality of treatment periods may be prescribed during which one or more prescribed stimuli are administered to the subject.

“Period” refers to the time over which a “dose” of stimulation is administered to a subject as part of the prescribed treatment plan.

The term “and/or” means one or all of the listed elements or a combination of any two or more of the listed elements.

The terms “comprises” and variations thereof do not have a limiting meaning where these terms appear in the description and claims.

5 Unless otherwise specified, “a,” “an,” “the,” “one or more,” and “at least one” are used interchangeably and mean one or more than one.

For any method disclosed herein that includes discrete steps, the steps may be conducted in any feasible order. And, as appropriate, any combination of two or more steps may be conducted simultaneously.

10 Also herein, the recitations of numerical ranges by endpoints include all numbers subsumed within that range (e.g., 1 to 5 includes 1, 1.5, 2, 2.75, 3, 3.80, 4, 5, etc.). Unless otherwise indicated, all numbers expressing quantities of components, molecular weights, and so forth used in the specification and claims are to be understood as being modified in all instances by the term “about.” Accordingly, unless otherwise indicated to the contrary, the
15 numerical parameters set forth in the specification and claims are approximations that may vary depending upon the desired properties sought to be obtained by the present invention. At the very least, and not as an attempt to limit the doctrine of equivalents to the scope of the claims, each numerical parameter should at least be construed in light of the number of reported significant digits and by applying ordinary rounding techniques.

20 Notwithstanding that the numerical ranges and parameters setting forth the broad scope of the invention are approximations, the numerical values set forth in the specific examples are reported as precisely as possible. All numerical values, however, inherently contain a range necessarily resulting from the standard deviation found in their respective testing measurements.

25 Ablative agents such as steam, heated gas or cryogens, such as, but not limited to, liquid nitrogen are inexpensive and readily available and are directed via the infusion port onto the tissue, held at a fixed and consistent distance, targeted for ablation. This allows for uniform distribution of the ablative agent on the targeted tissue. The flow of the ablative agent is controlled by a microprocessor according to a predetermined method based on the
30 characteristic of the tissue to be ablated, required depth of ablation, and distance of the port from the tissue. The microprocessor may use temperature, pressure or other sensing data to control the flow of the ablative agent. In addition, one or more suction ports are provided to suction the ablation agent from the vicinity of the targeted tissue. The targeted segment can

be treated by a continuous infusion of the ablative agent or via cycles of infusion and removal of the ablative agent as determined and controlled by the microprocessor.

It should be appreciated that the devices and embodiments described herein are implemented in concert with a controller that comprises a microprocessor executing control instructions. The controller can be in the form of any computing device, including desktop, laptop, and mobile device, and can communicate control signals to the ablation devices in wired or wireless form.

The present invention is directed towards multiple embodiments. The following disclosure is provided in order to enable a person having ordinary skill in the art to practice the invention. Language used in this specification should not be interpreted as a general disavowal of any one specific embodiment or used to limit the claims beyond the meaning of the terms used therein. The general principles defined herein may be applied to other embodiments and applications without departing from the spirit and scope of the invention. Also, the terminology and phraseology used is for the purpose of describing exemplary embodiments and should not be considered limiting. Thus, the present invention is to be accorded the widest scope encompassing numerous alternatives, modifications and equivalents consistent with the principles and features disclosed. For purpose of clarity, details relating to technical material that is known in the technical fields related to the invention have not been described in detail so as not to unnecessarily obscure the present

Figure 1 illustrates an ablation device, in accordance with an embodiment of the present invention. The ablation device comprises a catheter 10 having a distal centering or positioning attachment which is an inflatable balloon 11. The catheter 10 is made of or covered with an insulated material to prevent the escape of ablative energy from the catheter body. The ablation device comprises one or more infusion ports 12 for the infusion of ablative agent and one or more suction ports 13 for the removal of ablative agent. In one embodiment, the infusion port 12 and suction port 13 are the same. In one embodiment, the infusion ports 12 can direct the ablative agent at different angles. Ablative agent is stored in a reservoir 14 connected to the catheter 10. Delivery of the ablative agent is controlled by a microprocessor 15 and initiation of the treatment is controlled by a treating physician using an input device, such as a foot-paddle 16. In other embodiments, the input device could be a voice recognition system (that is responsive to commands such as “start”, “more”, “less”, etc.), a mouse, a switch, footpad, or any other input device known to persons of ordinary skill in the art. In one embodiment, microprocessor 15 translates signals from the input device, such as pressure being placed on the foot-paddle or vocal commands to provide “more” or

“less” ablative agent, into control signals that determine whether more or less ablative agent is dispensed. Optional sensor 17 monitors changes in an ablative tissue or its vicinity to guide flow of ablative agent. In one embodiment, optional sensor 17 also includes a temperature sensor. Optional infrared, electromagnetic, acoustic or radiofrequency energy emitters and sensors 18 measure the dimensions of the hollow organ.

In one embodiment, a user interface included with the microprocessor 15 allows a physician to define device, organ, and condition which in turn creates default settings for temperature, cycling, volume (sounds), and standard RF settings. In one embodiment, these defaults can be further modified by the physician. The user interface also includes standard displays of all key variables, along with warnings if values exceed or go below certain levels.

The ablation device also includes safety mechanisms to prevent users from being burned while manipulating the catheter, including insulation, and optionally, cool air flush, cool water flush, and alarms/tones to indicate start and stop of treatment.

In one embodiment, the inflatable balloon has a diameter of between 1 mm and 10 cm. In one embodiment, the inflatable balloon is separated from the ports by a distance of 1 mm to 10 cm. In one embodiment, the size of the port openings is between 1 μ m and 1 cm. It should be appreciated that the inflatable balloon is used to fix the device and therefore is configured to not contact the ablated area. The inflatable balloon can be any shape that contacts the hollow organ at 3 or more points. One of ordinary skill in the art will recognize that, using triangulation, one can calculate the distance of the catheter from the lesion. Alternatively, the infrared, electromagnetic, acoustic or radiofrequency energy emitters and sensors 18 can measure the dimensions of the hollow organ. The infrared, electromagnetic, acoustic or radiofrequency energy is emitted from the emitter 18 and is reflected back from the tissue to the detector in the emitter 18. The reflected data can be used to determine the dimension of the hollow cavity. It should be appreciated that the emitter and sensor 18 can be incorporated into a single transceiver that is capable of both emitting energy and detecting the reflected energy.

Figure 2A illustrates a longitudinal section of the ablation device, depicting a distribution of infusion ports. Figure 2B illustrates a cross section of a distribution of infusion ports on the ablation device, in accordance with an embodiment of the present invention. The longitudinal and cross sectional view of the catheter 10 as illustrated in Figures 2A and 2B respectively, show one arrangement of the infusion ports 12 to produce a uniform distribution of ablative agent 21 in order to provide a circumferential area of ablation in a hollow organ 20. Figure 2C illustrates a cross section of a distribution of infusion ports on the ablation

device, in accordance with another embodiment of the present invention. The arrangement of the infusion ports 12 as illustrated in Figure 2C produce a focal distribution of ablative agent 21 and a focal area of ablation in a hollow organ 20.

For all embodiments described herein, it should be appreciated that the size of the port, number of ports, and distance between the ports will be determined by the volume of ablative agent needed, pressure that the hollow organ can withstand, size of the hollow organ as measured by the distance of the surface from the port, length of the tissue to be ablated (which is roughly the surface area to be ablated), characteristics of the tissue to be ablated and depth of ablation needed. In one embodiment, there is at least one port opening that has a diameter between 1 μm and 1 cm. In another embodiment, there are two or more port openings that have a diameter between 1 μm and 1 cm and that are equally spaced around the perimeter of the device.

Figure 2D illustrates another embodiment of the ablation device. The vapor ablation catheter comprises an insulated catheter 21 with one or more positioning attachments 22 of known length 23. The vapor ablation catheter has one or more vapor infusion ports 25. The length 24 of the vapor ablation catheter 21 with infusion ports 25 is determined by the length or area of the tissue to be ablated. Vapor 29 is delivered through the vapor infusion ports 25. The catheter 21 is preferably positioned in the center of the positioning attachment 22, and the infusion ports 25 are arranged circumferentially for circumferential ablation and delivery of vapor. In another embodiment, the catheter 21 can be positioned toward the periphery of the positioning attachment 22 and the infusion ports 25 can be arranged non-circumferentially, preferably linearly on one side for focal ablation and delivery of vapor. The positioning attachment 22 is one of an inflatable balloon, a wire mesh disc with or without an insulated membrane covering the disc, a cone shaped attachment, a ring shaped attachment or a freeform attachment designed to fit the desired hollow body organ or hollow body passage, as further described below. Optional infrared, electromagnetic, acoustic or radiofrequency energy emitters and sensors 28 are incorporated to measure the dimensions of the hollow organ.

The vapor ablation catheter may also comprise an optional coaxial sheath 27 to restrain the positioning attachment 22 in a manner comparable to a coronary metal stent. In one embodiment, the sheath is made of memory metal or memory material with a compressed linear form and a non-compressed form in the shape of the positioning attachment. Alternatively, the channel of an endoscope may perform the function of restraining the positioning attachment 22 by, for example, acting as a constraining sheath. Optional sensor

26 is deployed on the catheter to measure changes associated with vapor delivery or ablation. The sensor is one of temperature, pressure, photo or chemical sensor.

Optionally, one or more, infrared, electromagnetic, acoustic or radiofrequency energy emitters and sensors 28 can measure the dimensions of the hollow organ. The infrared,
5 electromagnetic, acoustic or radiofrequency energy is emitted from the emitter 28 and is reflected back from the tissue to the detector in the emitter 28. The reflected data can be used to determine the dimension of the hollow cavity. The measurement is performed at one or multiple points to get an accurate estimate of the dimension of the hollow organ. The data can also be used to create a topographic representation of the hollow organ. Additional data from
10 diagnostic tests can be used to validate or add to the data from the above measurements.

FIG. 2E illustrates an ablation device 20 in the form of a catheter 21 extending from a conventional handle 22, in accordance with an embodiment of the present invention. The catheter 21 is of a type as described above and extends from and attaches to the handle 22. In one embodiment, the catheter 21 is insulated to protect the user from burns that could result
15 from hot vapor heating the catheter. In one embodiment, the catheter is composed of a material that will ensure that the outer temperature of the catheter will remain below 60° C during use. The handle 22 includes a pressure resistant port at the point of attachment with the catheter 21. The handle 22 also includes a flow channel within that directs vapor through to the catheter 21.

20 In one embodiment, the snare handle 22 includes a single attachment port 23 for the connection of a vapor stream and an RF feed. In another embodiment (not shown), the snare handle includes two separate attachment ports for the connection of a vapor stream and an RF feed. The attachment port 23 interfaces with the vapor supply cord via pressure-resistant connectors. In one embodiment, the connectors are of a luer lock type. In one embodiment,
25 the catheter 21 is a dual lumen catheter. The first lumen serves to deliver vapor to the site of ablation. In one embodiment, the vapor is released through small ports 24 positioned proximate the distal end of the catheter 21. The distal end of the catheter 21 is designed so that it can puncture the tissue to deliver vapor to the desired depth and location within the target tissue. In one embodiment, the distal end of the catheter 21 tapers to a point. The
30 second lumen houses the electrode used for RF ablation. In one embodiment, the delivery of vapor or RF waves is achieved through the use of a microprocessor. In another embodiment, the user can release vapor or subject the target tissue to RF waves by the use of actuators (not shown) on the handle 22. In one embodiment, the catheter has varying or differential insulation along its length. In one embodiment, the ablation device 20 includes a mechanism

in which a snare to grasp the tissue to be ablated and sizing the tissue in the snare is used to determine the amount of vapor to be delivered.

FIG. 2F illustrates a cross section of an ablation device 27 in the form of a catheter 21 extending from a conventional handle 22 with a pre-attached cord 25, in accordance with another embodiment of the present invention. The cord 25 attaches directly to the vapor delivery system, eliminating one interface between the system and the ablation device and thereby decreasing the chance of system failure as a result of disconnection. In this embodiment, the handle 22 includes a separate attachment port (not shown) for the RF or an electric feed.

FIG. 2G illustrates an ablation device 29 in the form of a catheter 21 extending from a conventional esophageal probe 26, in accordance with an embodiment of the present invention. In one embodiment, the catheter 21 is insulated and receives vapor from a flow channel contained within the probe 26. The catheter 21 includes a multitude of small ports 24 for the delivery of vapor to the target tissue. The delivery of vapor is controlled by a microprocessor. In one embodiment, the catheter 21 also includes two inflatable balloons 28, one at its distal end beyond the last vapor port 24, and one at its proximal end, proximate the catheter's 21 attachment to the probe 26. All vapor ports are positioned between these two balloons. Once the device 29 is inserted within the esophagus, the balloons 28 are inflated to keep the catheter 21 positioned and to contain the vapor within the desired treatment area. In one embodiment, the balloons must be separated from the ablation region by a distance of greater than 0 mm, preferably 1 mm and ideally 1 cm. In one embodiment, the diameter of each balloon when inflated is in the range of 10 to 100 mm, preferably 15-40 mm, although one of ordinary skill in the art would appreciate that the precise dimensions are dependent on the size of the patient's esophagus.

In one embodiment, the catheter 21 attached to the esophageal probe 26 is a dual lumen catheter. The first lumen serves to deliver vapor to the site of ablation as described above. The second lumen houses the electrode used for RF ablation.

Figure 3A illustrates the ablation device placed in an upper gastrointestinal tract with Barrett's esophagus to selectively ablate the Barrett's tissue, in accordance with an embodiment of the present invention. The upper gastrointestinal tract comprises Barrett's esophagus 31, gastric cardia 32, gastroesophageal junction 33 and displaced squamo-columnar junction 34. The area between the gastroesophageal junction 33 and the displaced squamo-columnar junction 34 is Barrett's esophagus 31, which is targeted for ablation. Distal to the cardia 32 is the stomach 35 and proximal to the cardia 32 is the esophagus 36.

The ablation device is passed into the esophagus 36 and the positioning device 11 is placed in the gastric cardia 32 abutting the gastroesophageal junction 33. This affixes the ablation catheter 10 and its ports 12 in the center of the esophagus 36 and allows for uniform delivery of the ablative agent 21 to the Barrett's esophagus 31.

5 In one embodiment, the positioning device is first affixed to an anatomical structure, not being subjected to ablation, before ablation occurs. Where the patient is undergoing circumferential ablation or first time ablation, the positioning attachment is preferably placed in the gastric cardia, abutting the gastroesophageal junction. Where the patient is undergoing a focal ablation of any residual disease, it is preferable to use the catheter system shown in
10 Figure 4B, as discussed below. In one embodiment, the positioning attachment must be separated from the ablation region by a distance of greater than 0 mm, preferably 1 mm and ideally 1 cm. In one embodiment, the size of the positioning device is in the range of 10 to 100 mm, preferably 20-40 mm, although one of ordinary skill in the art would appreciate that the precise dimensions are dependent on the size of the patient's esophagus.

15 The delivery of ablative agent 21 through the infusion port 12 is controlled by the microprocessor 15 coupled with the ablation device. The delivery of ablative agent is guided by predetermined programmatic instructions, depending on the tissue to be ablated and the depth of ablation required. In one embodiment, the target procedural temperature will need to be between -100 degrees Celsius and 200 degrees Celsius, preferably between 50 degrees
20 Celsius and 75 degrees Celsius, as further shown in the dosimetry table below. In one embodiment, esophageal pressure should not exceed 5 atm, and is preferably below 0.5 atm. In one embodiment, the target procedural temperature is achieved in less than 1 minute, preferably in less than 5 seconds, and is capable of being maintained for up to 10 minutes, preferably 1 to 10 seconds, and then cooled to body temperature. One of ordinary skill in the
25 art would appreciate that the treatment can be repeated until the desired ablation effect is achieved.

Optional sensor 17 monitors intraluminal parameters such as temperature and pressure and can increase or decrease the flow of ablative agent 21 through the infusion port 12 to obtain adequate heating or cooling, resulting in adequate ablation. The sensor 17 monitors
30 intraluminal parameters such as temperature and pressure and can increase or decrease the removal of ablative agent 21 through the optional suction port 13 to obtain adequate heating or cooling resulting in adequate ablation of Barrett's esophagus 31. Figure 3B illustrates the ablation device placed in an upper gastrointestinal tract with Barrett's esophagus to selectively ablate the Barrett's tissue, in accordance with another embodiment of the present

invention. As illustrated in FIG. 3B, the positioning device 11 is a wire mesh disc. In one embodiment, the positioning attachment must be separated from the ablation region by a distance of greater than 0 mm, preferably 1 mm and ideally 1 cm. In one embodiment, the positioning attachment is removably affixed to the cardia or gastroesophageal (EG) junction (for the distal attachment) or in the esophagus by a distance of greater than 0.1 mm, preferably around 1 cm, above the proximal most extent of the Barrett's tissue (for the proximal attachment).

FIG. 3B is another embodiment of the Barrett's ablation device where the positioning element 11 is a wire mesh disc. The wire mesh may have an optional insulated membrane to prevent the escape of the ablative agent. In the current embodiment, two wire mesh discs are used to center the ablation catheter in the esophagus. The distance between the two discs is determined by the length of the tissue to be ablated which, in this case, would be the length of the Barrett's esophagus. Optional infrared, electromagnetic, acoustic or radiofrequency energy emitters and sensors 18 are incorporated to measure the diameter of the esophagus.

FIG. 3C is a flowchart illustrating the basic procedural steps for using the ablation device, in accordance with an embodiment of the present invention. At step 302, a catheter of the ablation device is inserted into an organ which is to be ablated. For example, in order to perform ablation in a Barrett's esophagus of a patient, the catheter is inserted into the Barrett's esophagus via the esophagus of the patient.

At step 304, a positioning element of the ablation device is deployed and organ dimensions are measured. In an embodiment, where the positioning element is a balloon, the balloon is inflated in order to position the ablation device at a known fixed distance from the tissue to be ablated. In various embodiments, the diameter of the hollow organ may be predetermined by using radiological tests such as barium X-rays or computer tomography (CT) scan, or by using pressure volume cycle, i.e. by determining volume needed to raise pressure to a fixed level (for example, 1 atm) in a fixed volume balloon. In another embodiment, where the positioning device is disc shaped, circumferential rings are provided in order to visually communicate to an operating physician the diameter of the hollow organ. In various embodiments of the present invention, the positioning device enables centering of the catheter of the ablation device in a non-cylindrical body cavity, and the volume of the cavity is measured by the length of catheter or a uterine sound.

Optionally, one or more infrared, electromagnetic, acoustic or radiofrequency energy emitters and sensors can be used to measure the dimensions of the hollow organ. The infrared, electromagnetic, acoustic or radiofrequency energy is emitted from the emitter and

is reflected back from the tissue to a detector in the emitter. The reflected data can be used to determine the dimensions of the hollow cavity. The measurement can be performed at one or multiple points to get an accurate estimate of the dimensions of the hollow organ. The data from multiple points can also be used to create a topographic representation of the hollow organ or to calculate the volume of the hollow organ.

In one embodiment, the positioning attachment must be separated from the ports by a distance of 0 mm or greater, preferably greater than 0.1 mm, and more preferably 1 cm. The size of the positioning device depends on the hollow organ being ablated and ranges from 1 mm to 10 cm. In one embodiment, the diameter of the positioning element is between 0.01 mm and 100 mm. In one embodiment, the first positioning element comprises a circular body with a diameter between 0.01 mm and 10 cm.

At step 306, the organ is ablated by automated delivery of an ablative agent, such as steam, via infusion ports provided on the catheter. The delivery of the ablative agent through the infusion ports is controlled by a microprocessor coupled with the ablation device. The delivery of ablative agent is guided by predetermined programmatic instructions depending on the tissue to be ablated and the depth of ablation required. In an embodiment of the present invention where the ablative agent is steam, the dose of the ablative agent is determined by conducting dosimetry study to determine the dose to ablate endometrial tissue. The variable that enables determination of total dose of ablative agent is the volume (or mass) of the tissue to be treated which is calculated by using the length of the catheter and diameter of the organ (for cylindrical organs). The determined dose of ablative agent is then delivered using a micro-processor controlled steam generator. Optionally, the delivery of the ablative agent can be controlled by the operator using predetermined dosimetry parameters.

In one embodiment, the dose is provided by first determining what the disorder being treated is and what the desired tissue effect is, and then finding the corresponding temperature, as shown in Tables 1 and 2, below.

Table 1.

Temp in °C	Tissue Effect
------------	---------------

37-40	No significant tissue effect
41-44	Reversible cell damage in few hours
45-49	Irreversible cell damage at shorter intervals
50-69	Irreversible cell damage –ablation necrosis at shorter intervals
70	Threshold temp for tissue shrinkage, H-bond breakage
70-99	Coagulation and Hemostasis
100-200	Desiccation and Carbonization of tissue
> 200	Charring of tissue glucose

Table 2.

<u>Disorder</u>	<u>Max. Temp in °C</u>
<u>ENT / Pulmonary</u>	
Nasal Polyp	60-80
Turbinectomy	70-85
Bullous Disease	70-85
Lung Reduction	70-85
<u>Genitourinary</u>	
Uterine Menorrhagia	80-90
Endometriosis	80-90
Uterine Fibroids	90-100
Benign Prostatic Hypertrophy	90-100
<u>Gastroenterology</u>	
Barrett’s Esophagus	60-75
Esophageal Dysplasia	60-80
Vascular GI Disorders	55-75
Flat Polyps	60-80

In addition, the depth of ablation desired determines the holding time at the maximum temperature. For superficial ablation (Barrett), the holding time at the maximum temperature is very short (flash burn) and does not allow for heat to transfer to the deeper layers. This will prevent damage to deeper normal tissue and hence prevent patient discomfort and complications. For deeper tissue ablation, the holding time at the maximum temperature will be longer, thereby allowing the heat to percolate deeper.

Figure 4A illustrates the ablation device placed in a colon to ablate a flat colon polyp, in accordance with an embodiment of the present invention. The ablation catheter 10 is passed through a colonoscope 40. The positioning device 11 is placed proximal, with respect to the patient's GI tract, to a flat colonic polyp 41 which is to be ablated, in the normal colon 42. The positioning device 11 is one of an inflatable balloon, a wire mesh disc with or without an insulated membrane covering the disc, a cone shaped attachment, a ring shaped attachment or a freeform attachment designed to fit the colonic lumen. The positioning device 11 has the catheter 10 located toward the periphery of the positioning device 11 placing it closer to the polyp 41 targeted for non-circumferential ablation. Hence, the positioning device 11 fixes the catheter to the colon 42 at a predetermined distance from the polyp 41 for uniform and focused delivery of the ablative agent 21. The delivery of ablative agent 21 through the infusion port 12 is controlled by the microprocessor 15 attached to the ablation device and depends on tissue and the depth of ablation required. The delivery of ablative agent 21 is guided by predetermined programmatic instructions depending on the tissue to be ablated and the area and depth of ablation required. Optional infrared, electromagnetic, acoustic or radiofrequency energy emitters and sensors 18 are incorporated to measure the diameter of the colon. The ablation device allows for focal ablation of diseased polyp mucosa without damaging the normal colonic mucosa located away from the catheter ports.

In one embodiment, the positioning attachment must be separated from the ablation region by a distance of greater than 0.1 mm, ideally more than 5 mm. In one embodiment, the positioning element is proximal, with respect to the patient's GI tract, to the colon polyp.

Figure 4B illustrates the ablation device placed in a colon 42 to ablate a flat colon polyp 41, in accordance with another embodiment of the present invention. As illustrated in Figure 4B, the positioning device 11 is a conical attachment at the tip of the catheter 10. The conical attachment has a known length 'l' and diameter 'd' that is used to calculate the amount of thermal energy needed to ablate the flat colon polyp 41. Ablative agent 21 is directed from the infusion port 12 to polyp 41 by the positioning device 11. In one embodiment, the positioning attachment 11 must be separated from the ablation region by a distance of greater than 0.1 mm, preferably 1 mm and more preferably 1 cm. In one embodiment, the length 'l' is greater than 0.1 mm, preferably between 5 and 10 mm. In one embodiment, diameter 'd' depends on the size of the polyp and can be between 1 mm and 10 cm, preferably 1 to 5 cm. Optional infrared, electromagnetic, acoustic or radiofrequency energy emitters and sensors 18 are incorporated to measure the diameter of the colon. This

embodiment can also be used to ablate residual neoplastic tissue at the edges after endoscopic snare resection of a large sessile colon polyp.

Figure 5A illustrates the ablation device with a coaxial catheter design, in accordance with an embodiment of the present invention. The coaxial design has a handle 52a, an infusion port 53a, an inner sheath 54a and an outer sheath 55a. The outer sheath 55a is used to constrain the positioning device 56a in the closed position and encompasses ports 57a. Figure 5B shows a partially deployed positioning device 56b, with the ports 57b still within the outer sheath 55b. The positioning device 56b is partially deployed by pushing the catheter 54b out of sheath 55b.

Figure 5C shows a completely deployed positioning device 56c. The infusion ports 57c are out of the sheath 55c. The length 'l' of the catheter 54c that contains the infusion ports 57c and the diameter 'd' of the positioning element 56c are predetermined/known and are used to calculate the amount of thermal energy needed. Figure 5D illustrates a conical design of the positioning element. The positioning element 56d is conical with a known length 'l' and diameter 'd' that is used to calculate the amount of thermal energy needed for ablation. Figure 5E illustrates a disc shaped design of the positioning element 56e comprising circumferential rings 59e. The circumferential rings 59e are provided at a fixed predetermined distance from the catheter 54e and are used to estimate the diameter of a hollow organ or hollow passage in a patient's body.

Figure 6 illustrates an upper gastrointestinal tract with a bleeding vascular lesion being treated by the ablation device, in accordance with an embodiment of the present invention. The vascular lesion is a visible vessel 61 in the base of an ulcer 62. The ablation catheter 63 is passed through the channel of an endoscope 64. The conical positioning element 65 is placed over the visible vessel 61. The conical positioning element 65 has a known length 'l' and diameter 'd', which are used to calculate the amount of thermal energy needed for coagulation of the visible vessel to achieve hemostasis. The conical positioning element has an optional insulated membrane that prevents escape of thermal energy or vapor away from the disease site.

In one embodiment, the positioning attachment must be separated from the ablation region by a distance of greater than 0.1 mm, preferably 1 mm and more preferably 1 cm. In one embodiment, the length 'l' is greater than 0.1 mm, preferably between 5 and 10 mm. In one embodiment, diameter 'd' depends on the size of the lesion and can be between 1 mm and 10 cm, preferably 1 to 5 cm.

Figure 7 illustrates endometrial ablation being performed in a female uterus by using the ablation device, in accordance with an embodiment of the present invention. A cross-section of the female genital tract comprising a vagina 70, a cervix 71, a uterus 72, an endometrium 73, fallopian tubes 74, ovaries 75 and the fundus of the uterus 76 is illustrated.

5 A catheter 77 of the ablation device is inserted into the uterus 72 through the cervix 71. In an embodiment, the catheter 77 has two positioning elements, a conical positioning element 78 and a disc shaped positioning element 79. The positioning element 78 is conical with an insulated membrane covering the conical positioning element 78. The conical element 78 positions the catheter 77 in the center of the cervix 71 and the insulated membrane prevents

10 the escape of thermal energy or ablative agent through the cervix 71. The second disc shaped positioning element 79 is deployed close to the fundus of the uterus 76 positioning the catheter 77 in the middle of the cavity. An ablative agent 778 is passed through infusion ports 777 for uniform delivery of the ablative agent 778 into the uterine cavity. Predetermined length "l" of the ablative segment of the catheter and diameter "d" of the positioning element

15 79 allows for estimation of the cavity size and is used to calculate the amount of thermal energy needed to ablate the endometrial lining. Optional temperature sensors 7 deployed close to the endometrial surface are used to control the delivery of the ablative agent 778. Optional topographic mapping using multiple infrared, electromagnetic, acoustic or radiofrequency energy emitters and sensors can be used to define cavity size and shape in

20 patients with an irregular or deformed uterine cavity due to conditions such as fibroids. Additionally data from diagnostic testing can be used to ascertain the uterine cavity size, shape or other characteristics.

In an embodiment, the ablative agent is vapor or steam which contracts on cooling. Steam turns to water which has a lower volume as compared to a cryogen that will expand or

25 a hot fluid used in hydrothermal ablation whose volume stays constant. With both cryogens and hot fluids, increasing energy delivery is associated with increasing volume of the ablative agent which, in turn, requires mechanisms for removing the agent, otherwise the medical provider will run into complications, such as perforation. However, steam, on cooling, turns into water which occupies significantly less volume; therefore, increasing energy delivery is

30 not associated with an increase in volume of the residual ablative agent, thereby eliminating the need for continued removal. This further decreases the risk of leakage of the thermal energy via the fallopian tubes 74 or the cervix 71, thus reducing any risk of thermal injury to adjacent healthy tissue.

In one embodiment, the positioning attachment must be separated from the ablation region by a distance of greater than 0.1 mm, preferably 1 mm and more preferably 1 cm. In another embodiment, the positioning attachment can be in the ablated region as long as it does not cover a significant surface area. For endometrial ablation, 100% of the tissue does not need to be ablated to achieve the desired therapeutic effect.

In one embodiment, the preferred distal positioning attachment is an uncovered wire mesh that is positioned proximate to the mid body region. In one embodiment, the preferred proximal positioning device is a covered wire mesh that is pulled into the cervix, centers the device, and occludes the cervix. One or more such positioning devices may be helpful to compensate for the anatomical variations in the uterus. The proximal positioning device is preferably oval, with a long axis between 0.1 mm and 10 cm (preferably 1 cm to 5 cm) and a short axis between 0.1 mm and 5 cm (preferably 0.5 cm to 1 cm). The distal positioning device is preferably circular with a diameter between 0.1 mm and 10 cm, preferably 1 cm to 5 cm.

Figure 8 illustrates sinus ablation being performed in a nasal passage by using the ablation device, in accordance with an embodiment of the present invention. A cross-section of the nasal passage and sinuses comprising nares 81, nasal passages 82, frontal sinus 83, ethmoid sinus 84, and diseased sinus epithelium 85 is illustrated. The catheter 86 is inserted into the frontal sinus 83 or the ethmoid sinus 84 through the nares 81 and nasal passages 82.

In an embodiment, the catheter 86 has two positioning elements, a conical positioning element 87 and a disc shaped positioning element 88. The positioning element 87 is conical and has an insulated membrane covering. The conical element 87 positions the catheter 86 in the center of the sinus opening 80 and the insulated membrane prevents the escape of thermal energy or ablative agent through the opening. The second disc shaped positioning element 88 is deployed in the frontal sinus cavity 83 or ethmoid sinus cavity 84, positioning the catheter 86 in the middle of either sinus cavity. The ablative agent 8 is passed through the infusion port 89 for uniform delivery of the ablative agent 8 into the sinus cavity. The predetermined length "l" of the ablative segment of the catheter and diameter "d" of the positioning element 88 allows for estimation of the sinus cavity size and is used to calculate the amount of thermal energy needed to ablate the diseased sinus epithelium 85. Optional temperature sensors 888 are deployed close to the diseased sinus epithelium 85 to control the delivery of the ablative agent 8. In an embodiment, the ablative agent 8 is steam which contracts on cooling. This further decreases the risk of leakage of the thermal energy thus reducing any risk of thermal injury to adjacent healthy tissue. In one embodiment, the dimensional ranges

of the positioning elements are similar to those in the endometrial application, with preferred maximum ranges being half thereof. Optional topographic mapping using multiple infrared, electromagnetic, acoustic or radiofrequency energy emitters and sensors can be used to define cavity size and shape in patients with an irregular or deformed nasal cavity due to conditions such as nasal polyps.

Figure 9 illustrates bronchial and bullous ablation being performed in a pulmonary system by using the ablation device, in accordance with an embodiment of the present invention. A cross-section of the pulmonary system comprising bronchus 91, normal alveolus 92, bullous lesion 93, and a bronchial neoplasm 94 is illustrated.

In one embodiment, the catheter 96 is inserted through the channel of a bronchoscope 95 into the bronchus 91 and advanced into a bullous lesion 93. The catheter 96 has two positioning elements, a conical positioning element 97 and a disc shaped positioning element 98. The positioning element 97 is conical having an insulated membrane covering. The conical element 97 positions the catheter 96 in the center of the bronchus 91 and the insulated membrane prevents the escape of thermal energy or ablative agent through the opening into the normal bronchus. The second disc shaped positioning element 98 is deployed in the bullous cavity 93 positioning the catheter 96 in the middle of the bullous cavity 93. An ablative agent 9 is passed through the infusion port 99 for uniform delivery into the sinus cavity. Predetermined length 'l' of the ablative segment of the catheter 96 and diameter 'd' of the positioning element 98 allow for estimation of the bullous cavity size and is used to calculate the amount of thermal energy needed to ablate the diseased bullous cavity 93. Optionally, the size of the cavity can be calculated from radiological evaluation using a chest CAT scan or MRI. Optional temperature sensors are deployed close to the surface of the bullous cavity 93 to control the delivery of the ablative agent 9. In an embodiment, the ablative agent is steam which contracts on cooling. This further decreases the risk of leakage of the thermal energy into the normal bronchus thus reducing any risk of thermal injury to adjacent normal tissue.

In one embodiment, the positioning attachment must be separated from the ablation region by a distance of greater than 0.1 mm, preferably 1 mm and more preferably 1 cm. In another embodiment, the positioning attachment can be in the ablated region as long as it does not cover a significant surface area.

In one embodiment, there are preferably two positioning attachments. In another embodiment, the endoscope is used as one fixation point with one positioning element. The positioning device is between 0.1 mm and 5 cm (preferably 1 mm to 2 cm). The distal

positioning device is preferably circular with a diameter between 0.1 mm and 10 cm, preferably 1 cm to 5 cm.

In another embodiment for the ablation of a bronchial neoplasm 94, the catheter 96 is inserted through the channel of a bronchoscope 95 into the bronchus 91 and advanced across the bronchial neoplasm 94. The positioning element 98 is disc shaped having an insulated membrane covering. The positioning element 98 positions the catheter in the center of the bronchus 91 and the insulated membrane prevents the escape of thermal energy or ablative agent through the opening into the normal bronchus. The ablative agent 9 is passed through the infusion port 99 in a non-circumferential pattern for uniform delivery of the ablative agent to the bronchial neoplasm 94. The predetermined length “l” of the ablative segment of the catheter and diameter ‘d’ of the positioning element 98 are used to calculate the amount of thermal energy needed to ablate the bronchial neoplasm 94.

The catheter could be advanced to the desired location of ablation using endoscopic, laparoscopic, stereotactic or radiological guidance. Optionally the catheter could be advanced to the desired location using magnetic navigation.

Figure 10 illustrates prostate ablation being performed on an enlarged prostate in a male urinary system by using the device, in accordance with an embodiment of the present invention. A cross-section of a male genitourinary tract having an enlarged prostate 1001, bladder 1002, and urethra 1003 is illustrated. The urethra 1003 is compressed by the enlarged prostate 1001. The ablation catheter 1005 is passed through the cystoscope 1004 positioned in the urethra 1003 distal to the obstruction. The positioning elements 1006 are deployed to center the catheter in the urethra 1003 and one or more insulated needles 1007 are passed to pierce the prostate 1001. The vapor ablative agent 1008 is passed through the insulated needles 1007 thus causing ablation of the diseased prostatic tissue resulting in shrinkage of the prostate.

The size of the enlarged prostate could be calculated by using the differential between the extra-prostatic and intra-prostatic urethra. Normative values could be used as baseline. Additional ports for infusion of a cooling fluid into the urethra can be provided to prevent damage to the urethra while the ablative energy is being delivered to the prostate for ablation, thus preventing complications such as stricture formation.

In one embodiment, the positioning attachment must be separated from the ablation region by a distance of greater than 0.1 mm, preferably 1 mm to 5 mm and no more than 2 cm. In another embodiment, the positioning attachment can be deployed in the bladder and

pulled back into the urethral opening/neck of the bladder thus fixing the catheter. In one embodiment, the positioning device is between 0.1 mm and 10 cm in diameter.

Figure 11 illustrates fibroid ablation being performed in a female uterus by using the ablation device, in accordance with an embodiment of the present invention. A cross-section of a female genitourinary tract comprising a uterine fibroid 1111, uterus 1112, and cervix 1113 is illustrated. The ablation catheter 1115 is passed through the hysteroscope 1114 positioned in the uterus distal to the fibroid 1111. The ablation catheter 1115 has a puncturing tip 1120 that helps puncture into the fibroid 1111. The positioning elements 1116 are deployed to center the catheter in the fibroid and insulated needles 1117 are passed to pierce the fibroid tissue 1111. The vapor ablative agent 1118 is passed through the needles 1117 thus causing ablation of the uterine fibroid 1111 resulting in shrinkage of the fibroid.

Figure 12 illustrates a vapor delivery system using an RF heater for supplying vapor to the ablation device, in accordance with an embodiment of the present invention. In an embodiment, the vapor is used as an ablative agent in conjunction with the ablation device described in the present invention. RF heater 64 is located proximate a pressure vessel 42 containing a liquid 44. RF heater 64 heats vessel 42, in turn heating the liquid 44. The liquid 44 heats up and begins to evaporate causing an increase in pressure inside the vessel 42. The pressure inside vessel 42 can be kept fairly constant by providing a thermal switch 46 that controls resistive heater 64. Once the temperature of the liquid 44 reaches a predetermined temperature, the thermal switch 46 shuts off RF heater 64. The vapor created in pressure vessel 42 may be released via a control valve 50. As the vapor exits vessel 42, a pressure drop is created in the vessel resulting in a reduction in temperature. The reduction of temperature is measured by thermal switch 46, and RF heater 64 is turned back on to heat liquid 44. In one embodiment, the target temperature of vessel 42 may be set to approximately 108°C, providing a continuous supply of vapor. As the vapor is released, it undergoes a pressure drop, which reduces the temperature of the vapor to a range of approximately 90-100° C. As liquid 44 in vessel 42 evaporates and the vapor exits vessel 42, the amount of liquid 44 slowly diminishes. The vessel 42 is optionally connected to reservoir 43 containing liquid 44 via a pump 49 which can be turned on by the controller 24 upon sensing a fall in pressure or temperature in vessel 42, delivering additional liquid 44 to the vessel 42.

Vapor delivery catheter 16 is connected to vessel 42 via a fluid connector 56. When control valve 50 is open, vessel 42 is in fluid communication with delivery catheter 16 via connector 56. Control switch 60 may serve to turn vapor delivery on and off via actuator 48. For example, control switch 60 may physically open and close the valve 50, via actuator 48,

to control delivery of vapor stream from the vessel 42. Switch 60 may be configured to control other attributes of the vapor such as direction, flow, pressure, volume, spray diameter, or other parameters.

5 Instead of, or in addition to, physically controlling attributes of the vapor, switch 60 may electrically communicate with a controller 24. Controller 24 controls the RF heater 64, which in turn controls attributes of the vapor, in response to actuation of switch 60 by the operator. In addition, controller 24 may control valves temperature or pressure regulators associated with catheter 16 or vessel 42. A flow meter 52 may be used to measure the flow, pressure, or volume of vapor delivery via the catheter 16. The controller 24 controls the
10 temperature and pressure in the vessel 42 and the time, rate, flow, and volume of vapor flow through the control valve 50. These parameters are set by the operator 11. The pressure created in vessel 42, using the target temperature of 108° C, may be in the order of 25 pounds per square inch (psi) (1.72 bars).

Figure 13 illustrates a vapor delivery system using a resistive heater for supplying
15 vapor to the ablation device, in accordance with an embodiment of the present invention. In an embodiment, the generated vapor is used as an ablative agent in conjunction with the ablation device described in the present invention. Resistive heater 40 is located proximate a pressure vessel 42. Vessel 42 contains a liquid 44. Resistive heater 40 heats vessel 42, in turn heating liquid 44. Accordingly, liquid 44 heats and begins to evaporate. As liquid 44 begins
20 to evaporate, the vapor inside vessel 42 causes an increase in pressure in the vessel. The pressure in vessel 42 can be kept fairly constant by providing a thermal switch 46 that controls resistive heater 40. When the temperature of liquid 44 reaches a predetermined temperature, thermal switch 46 shuts off resistive heater 40. The vapor created in pressure vessel 42 may be released via a control valve 50. As the vapor exits vessel 42, vessel 42
25 experiences a pressure drop. The pressure drop of vessel 42 results in a reduction of temperature. The reduction of temperature is measured by thermal switch 46, and resistive heater 40 is turned back on to heat liquid 44. In one embodiment, the target temperature of vessel 42 may be set to approximately 108°C, providing a continuous supply of vapor. As the vapor is released, it undergoes a pressure drop, which reduces the temperature of the vapor to
30 a range of approximately 90-100° C. As liquid 44 in vessel 42 evaporates and the vapor exits vessel 42, the amount of liquid 44 slowly diminishes. The vessel 42 is connected to another vessel 43 containing liquid 44 via a pump 49 which can be turned on by the controller 24 upon sensing a fall in pressure or temperature in vessel 42 delivering additional liquid 44 to the vessel 42.

Vapor delivery catheter 16 is connected to vessel 42 via a fluid connector 56. When control valve 50 is open, vessel 42 is in fluid communication with delivery catheter 16 via connector 56. Control switch 60 may serve to turn vapor delivery on and off via actuator 48. For example, control switch 60 may physically open and close the valve 50, via actuator 48, to control delivery of vapor stream from the vessel 42. Switch 60 may be configured to control other attributes of the vapor such as direction, flow, pressure, volume, spray diameter, or other parameters. Instead of, or in addition to, physically controlling attributes of the vapor, switch 60 may electrically communicate with a controller 24. Controller 24 controls the resistive heater 40, which in turn controls attributes of the vapor, in response to actuation of switch 60 by the operator. In addition, controller 24 may control valves temperature or pressure regulators associated with catheter 16 or vessel 42. A flow meter 52 may be used to measure the flow, pressure, or volume of vapor delivery via the catheter 16. The controller 24 controls the temperature and pressure in the vessel 42 as well as time, rate, flow, and volume of vapor flow through the control valve 50. These parameters are set by the operator.

11. The pressure created in vessel 42, using the target temperature of 108°C, may be on the order of 25 pounds per square inch (psi) (1.72 bars).

Figure 14 illustrates a vapor delivery system using a heating coil for supplying vapor to the ablation device, in accordance with an embodiment of the present invention. In an embodiment, the generated vapor is used as an ablative agent in conjunction with the ablation device described in the present invention. The vapor delivery system includes a conventional generator 1400 that is commonly used in operating rooms to provide power to specialized tools, i.e., cutters. The generator 1400 is modified to include an integrated liquid reservoir 1401. In one embodiment, the reservoir 1401 is filled with room temperature pure water. The reservoir 1401 portion of the generator 1400 is connected to the heating component 1405 via a reusable active cord 1403. In one embodiment, the reusable active cord 1403 may be used up to 200 times. The cord 1403 is fixedly attached via connections at both ends to withstand operational pressures, and preferably a maximum pressure, such that the cord does not become disconnected. In one embodiment, the connections can resist at least 1 atm of pressure. In one embodiment, the connections are of a luer lock type. The cord 1403 has a lumen through which liquid flows to the heating component 1405. In one embodiment, the heating component 1405 contains a coiled length of tubing 1406. As liquid flows through the coiled tubing 1406, it is heated by the surrounding heating component 1405 in a fashion similar to a conventional heat exchanger. As the liquid is heated, it becomes vaporized. The heating component contains a connector 1407 that accommodates the outlet of vapor from the

coiled tubing 1406. One end of a single use cord 1408 attaches to the heating component 1405 at the connector 1407. The connector 1407 is designed to withstand pressures generated by the vapor inside the coiled tubing 1406 during operation. In one embodiment, the connector 1407 is of a luer lock type. An ablation device 1409 is attached to the other
5 end of the single use cord 1408 via a connection able to withstand the pressures generated by the system. In one embodiment, the ablation device is integrated with a catheter. In another embodiment, the ablation device is integrated with a probe. The single use cord 1408 has a specific luminal diameter and is of a specific length to ensure that the contained vapor does not condense into liquid while simultaneously providing the user enough slack to operate. In
10 addition, the single use cord 1408 provides sufficient insulation so that personnel will not suffer burns when coming into contact with the cord. In one embodiment, the single use cord has a luminal diameter of less than 3 mm, preferably less than 2.6 mm, and is longer than 1 meter in length.

In one embodiment, the system includes a foot pedal 1402 by which the user can
15 supply more vapor to the ablation device. Depressing the foot pedal 1402 allows liquid to flow from the reservoir 1401 into the heating component 1405 where it changes into vapor within the coiled tubing 1406. The vapor then flows to the ablation device via the single use tube 1408. The ablation device includes an actuator by which the user can open small ports on the device, releasing the vapor and ablating the target tissue.

20 Figure 15 illustrates the heating component 1505 and coiled tubing 1506 of the heating coil vapor delivery system of FIG. 14, in accordance with an embodiment of the present invention. Liquid arrives through a reusable active cord (not shown) at a connection 1502 on one side of the heating component 1505. The liquid then travels through the coiled tubing 1506 within the heating component 1505. The coiled tubing is composed of a material
25 and configured specifically to provide optimal heat transfer to the liquid. In one embodiment, the coiled tubing 1506 is copper. The temperature of the heating component 1505 is set to a range so that the liquid is converted to vapor as it passes through the coiled tubing 1506. In one embodiment, the temperature of the heating component 1505 can be set by the user through the use of a temperature setting dial 1508. In one embodiment, the heating
30 component contains an on/off switch 1509 and is powered through the use of an attached AC power cord 1503. In another embodiment, the heating component receives power through an electrical connection integrated into and/or facilitated by the active cord connection to the reservoir. The vapor passes through the end of the coiled tubing 1506 and out of the heating component 1505 through a connector 1507. In one embodiment, the connector 1507 is

located on the opposite side of the heating component 1505 from the inlet connection 1502. A single use cord (not shown) attaches to the connector 1507 and supplies vapor to the ablation device.

5 Figure 16A illustrates the unassembled interface connection between the ablation device 1608 and the single use cord 1601 of the heating coil vapor delivery system of FIG. 14, in accordance with an embodiment of the present invention. In this embodiment, the ablation device 1608 and single use cord 1601 are connected via a male-to-male double luer lock adapter 1605. The end of the single use cord 1601 is threaded to form a female end 1602 of a luer lock interface and connects to one end of the adapter 1605. The ablation
10 device 1608 includes a small protrusion at its non-operational end which is also threaded to form a female end 1607 of a luer lock interface and connects to the other end of the adapter 1605. The threading luer lock interface provides a secure connection and is able to withstand the pressures generated by the heating coil vapor delivery system without becoming disconnected.

15 FIG. 16B illustrates the assembled interface connection between the ablation device 1608 and the single use cord 1601 of the heating coil vapor delivery system of FIG. 14, in accordance with an embodiment of the present invention. The male-to-male double luer lock adapter 1605 is pictured securing the two components together. The double luer lock interface provides a stable seal, allows interchangeability between ablation devices, and
20 enables users to quickly replace single use cords.

FIG. 17 illustrates a vapor ablation system using a heater or heat exchange unit for supplying vapor to the ablation device, in accordance with another embodiment of the present invention. In the pictured embodiment, water for conversion to vapor is supplied in a disposable, single use sterile fluid container 1705. The container 1705 is sealed with a sterile
25 screw top 1710 that is punctured by a needle connector 1715 provided on a first end of a first filter member 1720. The second end of the first filter member 1720, opposite the first end, is connected to a pump 1725 for drawing the water from the fluid container 1705, through the first filter member 1720, and into the heater or heat exchange unit 1730. The system includes a microcontroller or microprocessor 1735 for controlling the actions of the pump 1725 and
30 heater or heat exchange unit 1730. The heater or heat exchange unit 1730 converts the water into vapor (steam). The increase in pressure generated during the heating step drives the vapor through an optional second filter member 1740 and into the ablation catheter 1750. In one embodiment, the heater or heat exchange unit 1730 includes a one-way valve at its proximal end to prevent the passage of vapor back toward the pump 1725. In various

embodiments, optional sensors 1745 positioned proximate the distal end of the catheter 1750 measure one or more of temperature, pressure, or flow of vapor and transmit the information to the microcontroller 1735, which in turn controls the rate of the pump 1725 and the level of vaporizing energy provided by the heater or heat exchange unit 1730.

5 FIG. 18 illustrates the fluid container 1805, first filter member 1820, and pump 1825 of the vapor ablation system of FIG. 17. As can be seen in the pictured embodiment, the system includes a water-filled, disposable, single use sterile fluid container 1805 and a pump 1825 with a first filter member 1820 disposed therebetween. The first filter member 1820 is connected to the container 1805 and pump 1825 by two first and second lengths of sterile
10 tubing 1807, 1822 respectively, and includes a filter for purifying the water used in the ablation system.

 Figures 19 and 20 illustrate first and second views respectively, of the fluid container 1905, 2005, first filter member 1920, 2020, pump 1925, 2025, heater or heat exchange unit 1930, 2030, and microcontroller 1935, 2035 of the vapor ablation system of FIG. 17. The
15 container 1905, 2005 is connected to the first filter member 1920, 2020 by a first length of sterile tubing 1907, 2007 and the first filter member 1920, 2020 is connected to the pump 1925, 2025 by a second length of sterile tubing 1922, 2022. A third length of sterile tubing 1927, 2027 connects the pump 1925, 2025 to the heater or heat exchange unit 1930, 2030. The microcontroller 1935, 2035, is operably connected to the pump 1925, 2025 by a first set
20 of control wires 1928, 2028 and to the heater or heat exchange unit 1930, 2030 by a second set of control wires 1929, 2029. The arrows 1901, 2001 depict the direction of the flow of water from the container 1905, 2005, through the first filter member 1920, 2020 and pump 1925, 2025 and into the heater or heat exchange member 1930, 2030 where it is converted to vapor. Arrow 1931, 2031 depicts the direction of flow of vapor from the heater or heat
25 exchange unit 1930, 2030 into the ablation catheter (not shown) for use in the ablation procedure.

 FIG. 21 illustrates the unassembled first filter member 2120 of the vapor ablation system of FIG. 17, depicting the filter 2122 positioned within. In one embodiment, the first filter member 2120 includes a proximal portion 2121, a distal portion 2123, and a filter 2122.
30 The proximal portion 2121 and distal portion 2123 secure together and hold the filter 2122 within. Also depicted in FIG. 21 are the disposable, single use sterile fluid container 2105 and the first length of sterile tubing 2107 connecting the container 2105 to the proximal portion 2121 of the first filter member 2120.

FIG. 22 illustrates one embodiment of the microcontroller 2200 of the vapor ablation system of FIG. 17. In various embodiments, the microcontroller 2200 includes a plurality of control wires 2228 connected to the pump and heater or heat exchange unit for controlling said components and a plurality of transmission wires 2247 for receiving flow, pressure, and temperature information from optional sensors positioned proximate the distal end of the ablation catheter.

FIG. 23 illustrates one embodiment of a catheter assembly 2350 for use with the vapor ablation system of FIG. 17. Vapor is delivered from the heater or heat exchange unit to the catheter assembly 2350 via a tube 2348 attached to the proximal end of a connector component 2352 of the assembly 2350. A disposable catheter 2356 with a fixedly attached disposable length of flexible tubing 2358 at its distal end is fitted over the connector component 2352. A second filter member 2354 is positioned between the connector component 2352 and the disposable catheter 2356 for purifying the vapor supplied by the heater or heat exchange unit. The connector component 2352 includes two washers 2353 positioned apart a short distance at its distal end to engage the overlaying disposable catheter 2356 and form a double-stage seal, thereby preventing vapor leakage between the components. Once the disposable catheter 2356 has been fitted to the distal end of the connector component 2352, a catheter connector 2357 is slid over the disposable flexible tubing 2358 and disposable catheter 2356 and is then snapped into place onto the connector component 2352. The catheter connector 2357 acts to keep the disposable catheter 2356 in place and also assists in preventing vapor leakage. In various embodiments, the disposable flexible tubing 2358 includes one or more holes or ports 2359 at or proximate its distal end for the delivery of ablative vapor to target tissues.

FIG. 24 illustrates one embodiment of a heat exchange unit 2430 for use with the vapor ablation system of FIG. 17. The heat exchange unit 2430 comprises a length of coiled tubing 2435 surrounded by a heating element 2434. Water 2432 enters the coiled tubing 2435 of the heat exchange unit 2430 at an entrance port 2433 proximate a first end of said heat exchange unit 2430. As the water 2432 flows within the coiled tubing 2435, it is converted into vapor (steam) 2438 by the heat emanating from said coiled tubing 2435 which has been heated by the heating element 2434. The vapor 2438 exits the coiled tubing 2435 of the heat exchange unit 2430 at an exit port 2437 proximate a second end of said heat exchange unit 2430 and is then delivered to the ablation catheter (not shown) for use in the ablation procedure.

FIG. 25 illustrates another embodiment of a heat exchange unit 2560 for use with the vapor ablation system of the present invention. In the pictured embodiment, the heat exchange unit 2560 comprises a cylindrically shaped, pen sized 'clamshell' style heating block. The heating block of the heat exchange unit 2560 includes a first half 2561 and a second half 2562 fixedly attached by a hinge 2563 along one side, wherein the halves 2561, 2562 fold together and connect on the opposite side. In one embodiment, the sides of the halves opposite sides with the hinge include a clasp for holding the two halves together. In one embodiment, one of the halves includes a handle 2564 for manipulating the heat exchange unit 2560. When the halves are folded together, the heat exchange unit 2560 snugly envelopes a cylindrically shaped catheter fluid heating chamber 2551 attached to, in-line and in fluid communication with, the proximal end of the ablation catheter 2550. Each half 2561, 2562 of the heat exchange unit 2560 includes a plurality of heating elements 2565 for heating the block. The positioning and fit of the heating block place it in close thermal contact with the catheter fluid heating chamber 2551. When in operation, the heating elements 2565 heat the heating block which transfers heat to the catheter fluid heating chamber 2551, which in turn heats the water inside the chamber 2551, converting said water to vapor. The heating block does not directly contact the water. In one embodiment, the catheter fluid heating chamber 2551 comprises a plurality of linear indentations 2591 stretching along the length of the component and in parallel with the heating elements 2565. Upon closing the halves 2561, 2562, the heating elements 2565, which optionally protrude from the internal surfaces of the halves 2561, 2562 contact, and fit within, the linear indentations 2591. This also increases the surface area of contact between the heating block and the heating chamber, improving the efficiency of heat exchange.

A luer fitting coupler 2549 is provided at the proximal end of the catheter fluid heating chamber 2551 for connecting a tube supplying sterile water. In one embodiment, a one-way valve is included at the proximal end of the catheter fluid heating chamber 2551, distal to the luer fitting 2549, to prevent the passage of vapor under pressure toward the water supply.

As described above, the catheter fluid heating chamber is designed as part of the ablation catheter and, along with the remainder of the catheter, is single use and disposable. In another embodiment, the chamber is reusable, in which case the luer fitting is positioned between the catheter shaft and the chamber. The heating block is designed to be axially aligned with the heating chamber when in use, is reusable, and will not be damaged in the event that it falls to the floor. In one embodiment, the weight and dimensions of the heating

block are designed such that it can be integrated into a pen-sized and shaped handle of the ablation catheter. The handle is thermally insulated to prevent injury to the operator.

In one embodiment, the heating block receives its power from a console which is itself line powered and designed to provide 700 - 1000 W of power, as determined by the fluid vaporization rate. The heating block and all output connections are electrically isolated from line voltage. In one embodiment, the console includes a user interface allowing adjustment of power with a commensurate fluid flow rate. In addition, in one embodiment, a pump, such as a syringe pump, is used to control the flow of fluid to the heating chamber and heating element. In one embodiment, the volume of the syringe is at least 10 ml and is ideally 60 ml.

In the above embodiment, the catheter to be used with the vapor ablation system is designed using materials intended to minimize cost. In one embodiment, the tubing used with the catheter is able to withstand a temperature of at least 125° C and can flex through an endoscope's bend radius (approximately 1 inch) without collapse. In one embodiment, the section of the catheter that passes through an endoscope is 7 French (2.3 mm) diameter and has a minimum length of 215 cm. In one embodiment, thermal resistance is provided by the catheter shaft material which shields the endoscope from the super-heated vapor temperature. In one embodiment, the heat exchange unit is designed to interface directly with, or in very close proximity to, an endoscope's biopsy channel to minimize the likelihood of a physician handling heated components. Having the heat exchange unit in close proximity to the endoscope handle also minimizes the length of the catheter through which the vapor needs to travel, thus minimizing heat loss and premature condensation.

In various embodiments, other means are used to heat the fluid within the catheter fluid heating chamber. FIG. 26 illustrates the use of induction heating to heat a chamber 2605. When an alternating electric current is passed through a coil of wire within the chamber 2605, the coil creates a magnetic field. The magnetic lines of flux 2610 cut through the air around the coil. When the chamber 2605 is composed of a ferrous material, such as, iron, stainless steel, or copper, electrical currents known as eddy currents are induced to flow in the chamber 2605, resulting in localized heating of the chamber 2605.

FIG. 27A illustrates one embodiment of a coil 2770 used with induction heating in the vapor ablation system of the present invention. The coil is positioned surrounding the catheter fluid heating chamber 2751. An alternating current passing through the coil creates a magnetic field and results in heating of the catheter fluid heating chamber 2751. The heated chamber heats the fluid within, converting it into a vapor, which passes into the catheter 2750

for use in the ablation procedure. The coil itself does not heat, making it safe to touch. A luer fitting coupler 2749 is provided at the proximal end of the catheter fluid heating chamber 2751 for connecting a tube supplying sterile water. In one embodiment, a one-way valve (not shown) is included at the proximal end of the catheter fluid heating chamber 2751, distal to the luer fitting 2749, to prevent the passage of vapor toward the water supply. In one embodiment, thermal insulating material (not shown) is positioned between the coil 2770 and the heating chamber 2751. In another embodiment, the chamber 2751 is suspended in the center of the coil 2770 with no physical contact between the two. In this embodiment, the intervening air acts as a thermally insulating material. The design of the chamber is optimized to increase its surface area to maximize contact and heat transfer, in turn resulting in more efficient vapor generation.

FIG. 27B illustrates one embodiment of a catheter handle 2772 used with induction heating in the vapor ablation system of the present invention. The handle 2772 is thermally insulated and incorporates an induction coil. In one embodiment, the handle 2772 includes an insulated tip 2773 at its distal end that engages with an endoscope channel after the catheter is inserted into the endoscope. The catheter 2750 is connected to the heating chamber 2751 which in turn is connected with the pump via an insulated connector 2774. In one embodiment, the heating chamber 2751 length and diameter are less than those of the handle 2772 and the induction coil, thus the heating chamber 2751 can slide inside the handle 2772 in a coaxial fashion while maintaining a constant position within the magnetic field generated by the induction coil. The operator can manipulate the catheter 2750 by grasping on the insulated connector 2774 and moving it in and out of the handle 2772 which in turn moves the catheter tip in and out of the distal end of the endoscope. In this design, the heated portions of the catheter 2750 are within the channel of the endoscope and in the insulated handle 2772, thus not coming into contact with the operator at anytime during the operation. An optional sensor 2775 on the insulated tip 2773 can sense when the catheter is not engaged with the endoscope and temporarily disable the heating function of the catheter to prevent accidental activation and thermal injury to the operator. With respect to FIG. 27B, the catheter 2750 and heating chamber 2751 are the heated components of the system while the handle 2772, insulated tip 2773, and insulated connector 2774 are the cool components and therefore safe to touch by the user.

Figures 28A and 28B are front and longitudinal view cross sectional diagrams respectively, illustrating one embodiment of a catheter 2880 used with induction heating in the vapor ablation system of the present invention. The catheter 2880 includes an insulated

handle 2886 that contains a heating chamber 2851 and an induction coil 2884. The heating chamber 2851 includes a luer lock 2849 at its proximal end. The luer lock 2849 has a one-way valve that prevents the backward flow of vapor from the chamber 2851. Vaporization of fluid in the chamber results in volume expansion and an increase in pressure which pushes the vapor out of the chamber 2849 and into the catheter body. The induction coil 2884 includes a wire 2886 that extends from the proximal end of the catheter 2880 for the delivery of an alternating current. The handle 2886 is connected to the catheter 2880 with an outer insulating sheath 2881 made of a thermally insulating material.

In various embodiments, the insulating material is polyether ether ketone (PEEK), polytetrafluoroethylene (PTFE), fluorinated ethylene propylene (FEP), polyether block amide (PEBA), polyimide, or a similar material. In various embodiments, optional sensors 2887 positioned proximate the distal end of the catheter 2880 measure one or more of temperature, pressure, or flow of vapor and transmit the information to a microprocessor, which in turn controls the flow rate of the fluid and the level of vaporizing energy provided to the chamber 2851. The microcontroller adjusts fluid flow rate and chamber temperature based on the sensed information, thereby controlling the flow of vapor and in turn, the flow of ablative energy to the target tissue.

In one embodiment, the catheter 2880 includes an inner flexible metal skeleton 2883. In various embodiments, the skeleton 2883 is composed of copper, stainless steel, or another ferric material. The skeleton 2883 is in thermal contact with the heating chamber 2851 so that the heat from the chamber 2851 is passively conducted through the metal skeleton 2883 to heat the inside of the catheter 2880, thus maintaining the steam in a vaporized state and at a relatively constant temperature. In various embodiments, the skeleton 2883 extends through a particular portion or the entire length of the catheter 2880. In one embodiment, the skeleton 2883 includes fins 2882 at regular intervals that keep the skeleton 2883 in the center of the catheter 2880 for uniform heating of the catheter lumen.

In another embodiment, as seen in FIG. 28C, the catheter includes an inner metal spiral 2888 in place of the skeleton. In yet another embodiment, as seen in FIG. 28D, the catheter includes an inner metal mesh 2889 in place of the skeleton. Referring to FIG.'s 28B, 28C, and 28D simultaneously, water 2832 enters the luer lock 2849 at a predetermined rate. It is converted to vapor 2838 in the heating chamber 2851. The metal skeleton 2883, spiral 2888, and mesh 2889 all conduct heat from the heating chamber 2851 into the catheter lumen to prevent condensation of the vapor in the catheter and insure that ablating vapor will exit the catheter from one or more holes or ports at its distal end.

FIG. 29 illustrates one embodiment of a heating unit 2990 using microwaves 2991 to convert fluid to vapor in the vapor ablation system of the present invention. The microwaves 2991 are directed toward the catheter fluid heating chamber 2951, heating the chamber 2951 and converting the fluid within into vapor. The vapor passes into the catheter 2950 for use in the ablation procedure. A luer fitting coupler 2949 is provided at the proximal end of the catheter fluid heating chamber 2951 for connecting a tube supplying sterile water. In one embodiment, a one-way valve (not shown) is included at the proximal end of the catheter fluid heating chamber 2951, distal to the luer fitting 2949, to prevent the passage of vapor toward the water supply.

In various embodiments, other energy sources, such as, High Intensity Focused Ultrasound (HIFU) and infrared energy, are used to heat the fluid in the catheter fluid heating chamber.

One advantage of a vapor delivery system utilizing a heating coil is that the vapor is generated closer to the point of use. Traditional vapor delivery systems often generate vapor close to or at the point in the system where the liquid is stored. The vapor must then travel through a longer length of tubing, sometimes over 2 meters, before reaching the point of use. As a result of the distance traveled, the system can sometimes deliver hot liquid as the vapor cools in the tubing from the ambient temperature.

The device and method of the present invention can be used to cause controlled focal or circumferential ablation of targeted tissue to varying depth in a manner in which complete healing with re-epithelialization can occur. Additionally, the vapor could be used to treat/ablate benign and malignant tissue growths resulting in destruction, liquefaction and absorption of the ablated tissue. The dose and manner of treatment can be adjusted based on the type of tissue and the depth of ablation needed. The ablation device can be used not only for the treatment of Barrett's esophagus and esophageal dysplasia, flat colon polyps, gastrointestinal bleeding lesions, endometrial ablation, pulmonary ablation, but also for the treatment of any mucosal, submucosal or circumferential lesion, such as inflammatory lesions, tumors, polyps and vascular lesions. The ablation device can also be used for the treatment of focal or circumferential mucosal or submucosal lesions of any hollow organ or hollow body passage in the body. The hollow organ can be one of gastrointestinal tract, pancreaticobiliary tract, genitourinary tract, respiratory tract or a vascular structure such as blood vessels. The ablation device can be placed endoscopically, radiologically, surgically or under direct visualization. In various embodiments, wireless endoscopes or single fiber endoscopes can be incorporated as a part of the device. In another embodiment, magnetic or

stereotactic navigation can be used to navigate the catheter to the desired location. Radio-opaque or sonolucent material can be incorporated into the body of the catheter for radiological localization. Ferro- or ferrimagnetic materials can be incorporated into the catheter to help with magnetic navigation.

5 While the exemplary embodiments of the present invention are described and illustrated herein, it will be appreciated that they are merely illustrative. It will be understood by those skilled in the art that various changes in form and detail may be made therein without departing from or offending the spirit and scope of the invention.

10

CLAIMS

We claim:

1. A tissue ablation device, comprising:
 - a. A liquid reservoir, wherein said reservoir includes an outlet connector that can resist at least 1 atm of pressure for the attachment of a reusable cord;
 - b. A heating component comprising:
 - i. a length of coiled tubing contained within a heating element, wherein activation of said heating element causes said coiled tubing to increase from a first temperature to a second temperature and wherein said increase causes a conversion of liquid within said coiled tubing to vapor; and
 - ii. an inlet connected to said coiled tubing;
 - iii. an outlet connected to said coiled tubing; and
 - iv. at least one pressure-resistant connection attached to the inlet and/or outlet;
 - c. A cord connecting the outlet of said reservoir to the inlet of the heating component;
 - d. A single use cord connecting a pressure-resistant inlet port of a vapor based ablation device to the outlet of said heating component.
2. The tissue ablation device of claim 1, wherein said liquid reservoir is integrated within an operating room equipment generator.
3. The tissue ablation device of claim 1, wherein said liquid is water and said vapor is steam.
4. The tissue ablation device of claim 1, wherein said pressure-resistant connections are luer lock connections.
5. The tissue ablation device of claim 1, wherein said coiled tubing is copper.
6. The tissue ablation device of claim 1, further comprising a foot pedal, wherein only when said foot pedal is pressed, vapor is generated and passed into said single use cord.
7. The tissue ablation device of claim 1, further comprising a foot pedal, wherein only when pressure is removed from said foot pedal, vapor is generated and passed into said single use cord.
8. A vapor ablation system comprising:
 - a. a container with a sterile liquid therein;
 - b. a pump in fluid communication with said container;
 - c. a first filter disposed between and in fluid communication with said container and said pump;
 - d. a heating component in fluid communication with said pump;

- e. a valve disposed between and in fluid communication with said pump and heating container;
 - f. a catheter in fluid communication with said heating component, said catheter comprising at least one opening at its operational end; and,
 - g. a microprocessor in operable communication with said pump and said heating component, wherein said microprocessor controls the pump to control a flow rate of the liquid from said container, through said first filter, through said pump, and into said heating component, wherein said liquid is converted into vapor via the transfer of heat from said heating component to said fluid, wherein said conversion of said fluid into said vapor results is a volume expansion and a rise in pressure where said rise in pressure forces said vapor into said catheter and out said at least one opening, and wherein a temperature of said heating component is controlled by said microprocessor.
9. The vapor ablation system of claim 8, further comprising at least one sensor on said catheter, wherein information obtained by said sensor is transmitted to said microprocessor, and wherein said information is used by said microprocessor to regulate said pump and said heating component and thereby regulate vapor flow.
10. The vapor ablation system of claim 9, wherein said at least one sensor includes one or more of a temperature sensor, flow sensor, or pressure sensor.
11. The vapor ablation system of claim 8, further comprising a screw cap on said liquid container and a puncture needle on said first filter, wherein said screw cap is punctured by said puncture needle to provide fluid communication between said container and said first filter.
12. The vapor ablation system of claim 8, wherein said liquid container and said catheter are disposable and configured for a single use.
13. The vapor ablation system of claim 8, wherein said fluid container, first filter, pump, heating component, and catheter are connected by sterile tubing and wherein the connections between said pump and said heating component and said heating component and said catheter are pressure resistant.
14. A tissue ablation system comprising:
- a. a catheter with a proximal end and a distal end and a lumen therebetween, said catheter comprising: a handle proximate the proximal end of said catheter and housing a fluid heating chamber and a heating element enveloping said chamber, a wire extending distally from said heating element and leading to a controller; an

- insulating sheath extending and covering the length of said catheter and disposed between said handle and said heating element at said distal end of said catheter; and, at least one opening proximate the distal end of said catheter for the passage of vapor; and,
- b. a controller operably connected to said heating element via said wire, wherein said controller is capable of modulating energy supplied to said heating element and further wherein said controller is capable of adjusting a flow rate of liquid supplied to said catheter;
 - c. wherein liquid is supplied to said heating chamber and then converted to vapor within said heating chamber by a transfer of heat from said heating element to said chamber, wherein said conversion of said liquid to vapor results in a volume expansion and a rise in pressure within said catheter, and wherein said rise in pressure pushes said vapor through said catheter and out said at least one opening.
15. The tissue ablation system of claim 14, further comprising a pressure resistant fitting attached to said fluid supply and a one-way valve in said pressure resistant fitting to prevent a backflow of vapor into the fluid supply.
16. The tissue ablation system of claim 14, further comprising at least one sensor on said catheter, wherein information obtained by said sensor is transmitted to said microprocessor, and wherein said information is used by said microprocessor to regulate said pump and said heating component and thereby regulate vapor flow.
17. The tissue ablation system of claim 14, further comprising a metal frame within said catheter, wherein said metal frame is in thermal contact with said heating chamber and conducts heat to said catheter lumen, thereby preventing condensation of said vapor.
18. The tissue ablation system of claim 17, wherein said metal frame comprises a metal skeleton with outwardly extending fins at regularly spaced intervals, a metal spiral, or a metal mesh and wherein said metal frame comprises at least one of copper, stainless steel, or another ferric material.
19. The tissue ablation system of claim 14, wherein said heating element comprises a heating block, wherein said heating block is supplied power by said controller.
20. The tissue ablation system of claim 14, wherein said heating element uses one of magnetic induction, microwave, high intensity focused ultrasound, or infrared energy to heat said heating chamber and the fluid therein.

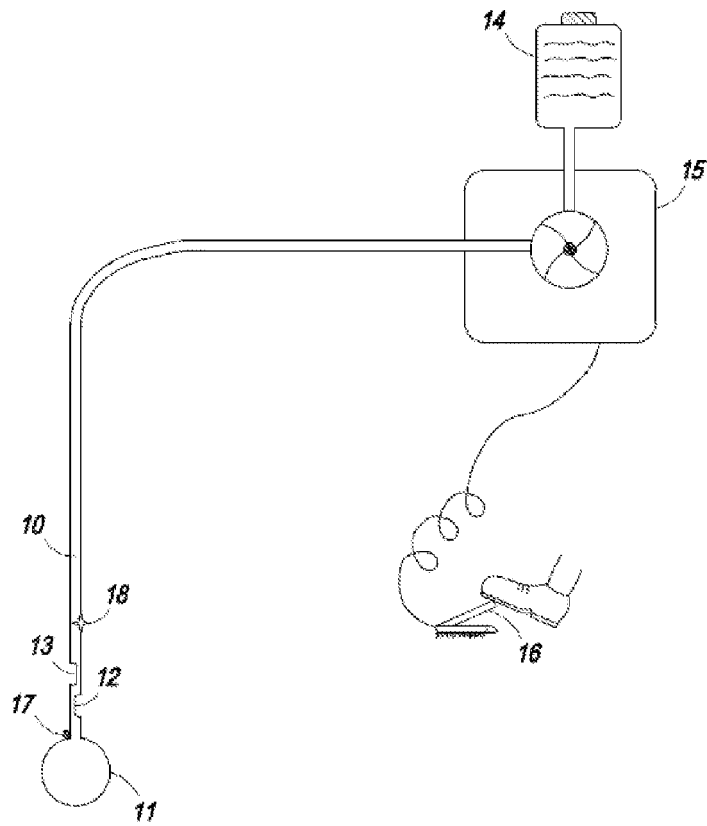
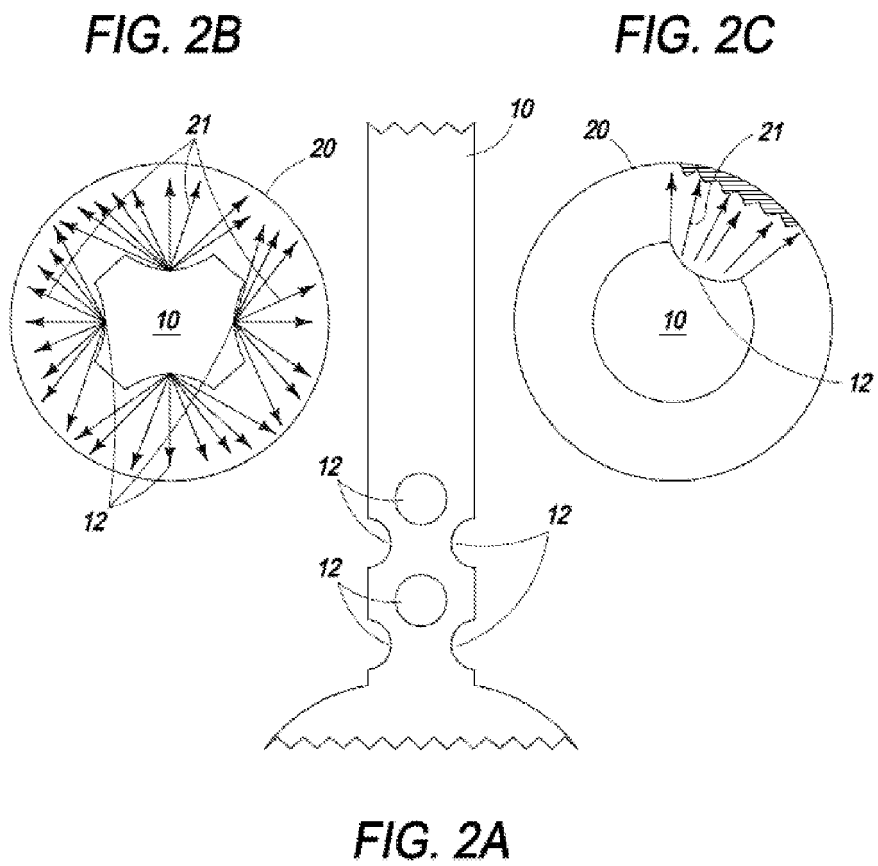

FIG. 1



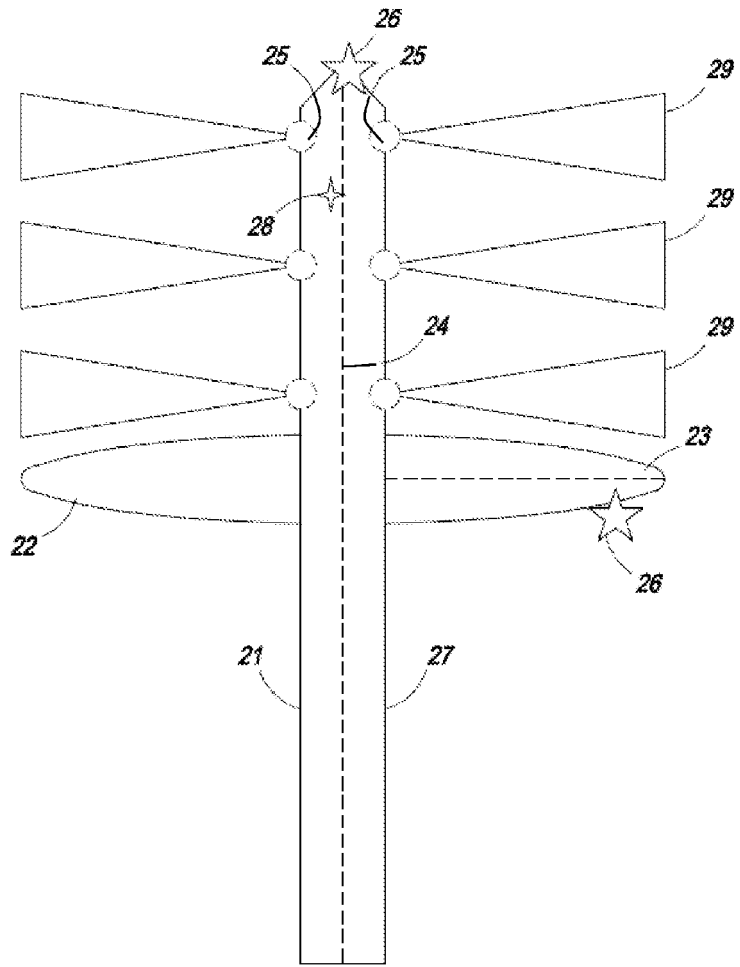
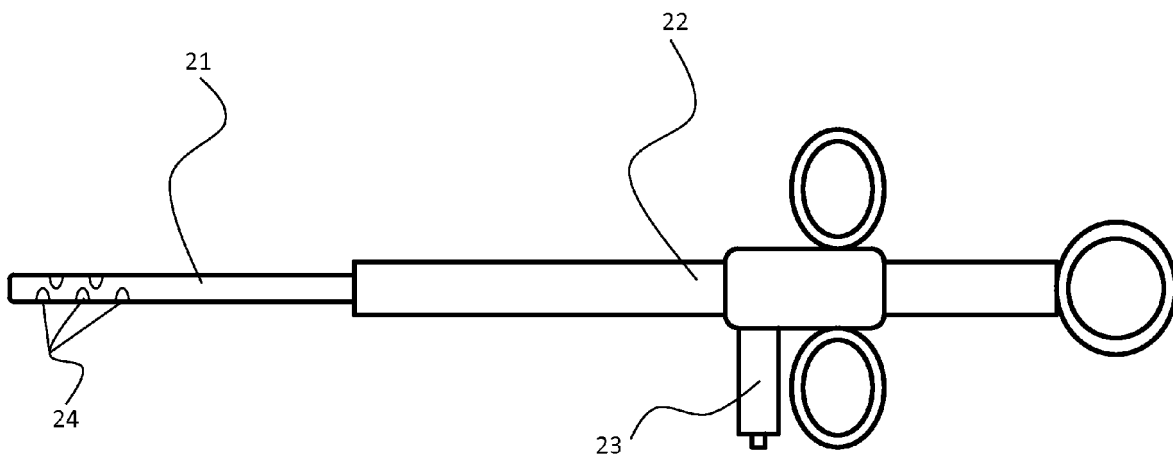

FIG. 2D



20

FIG. 2E

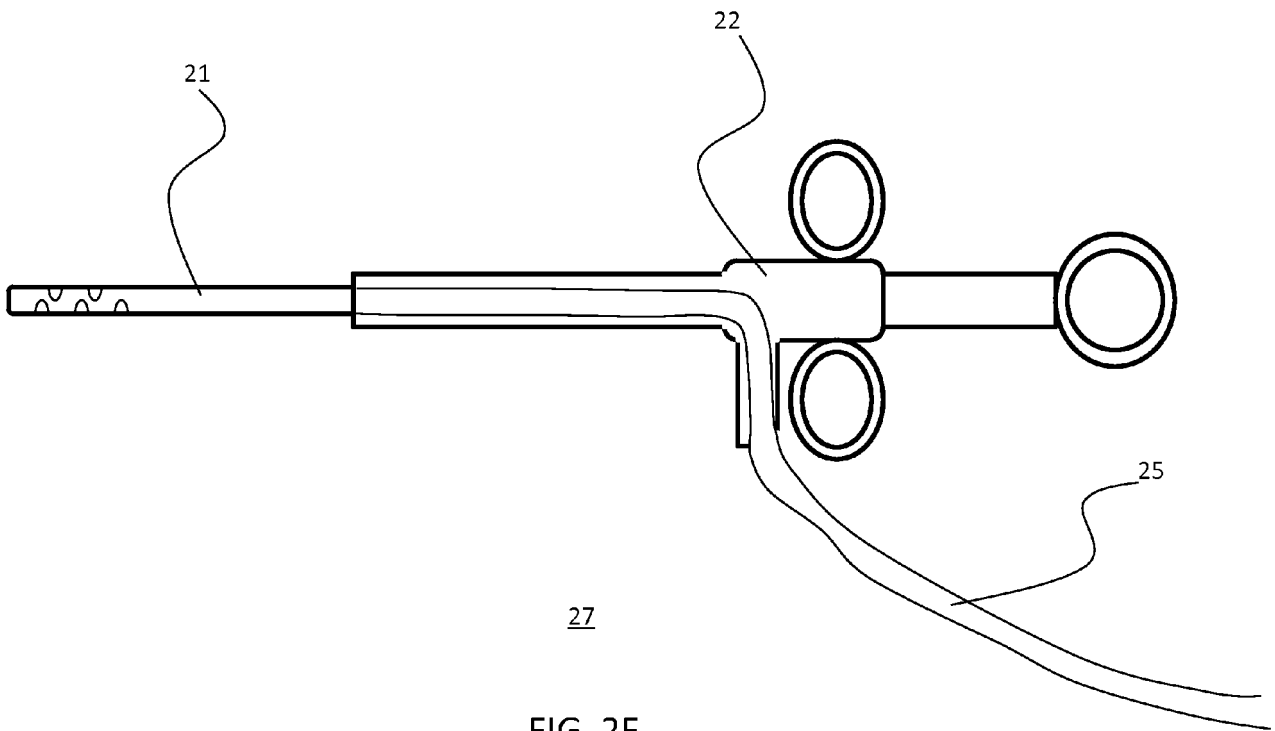

FIG. 2F

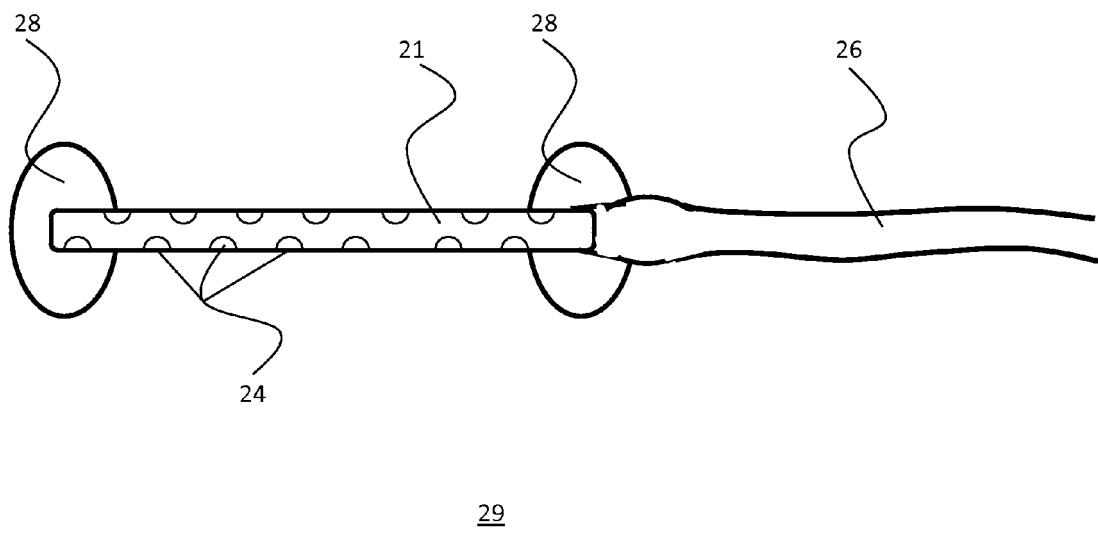

FIG. 2G

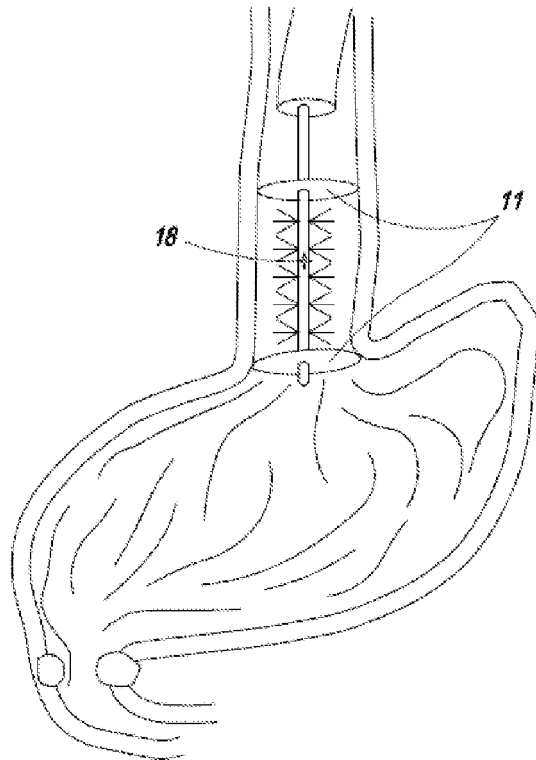

FIG. 3B

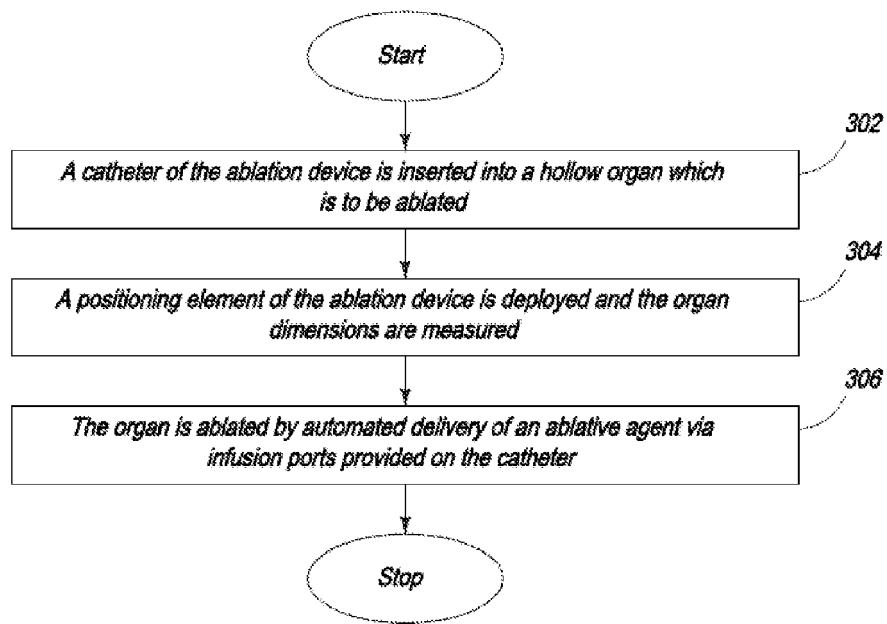

FIG. 3C

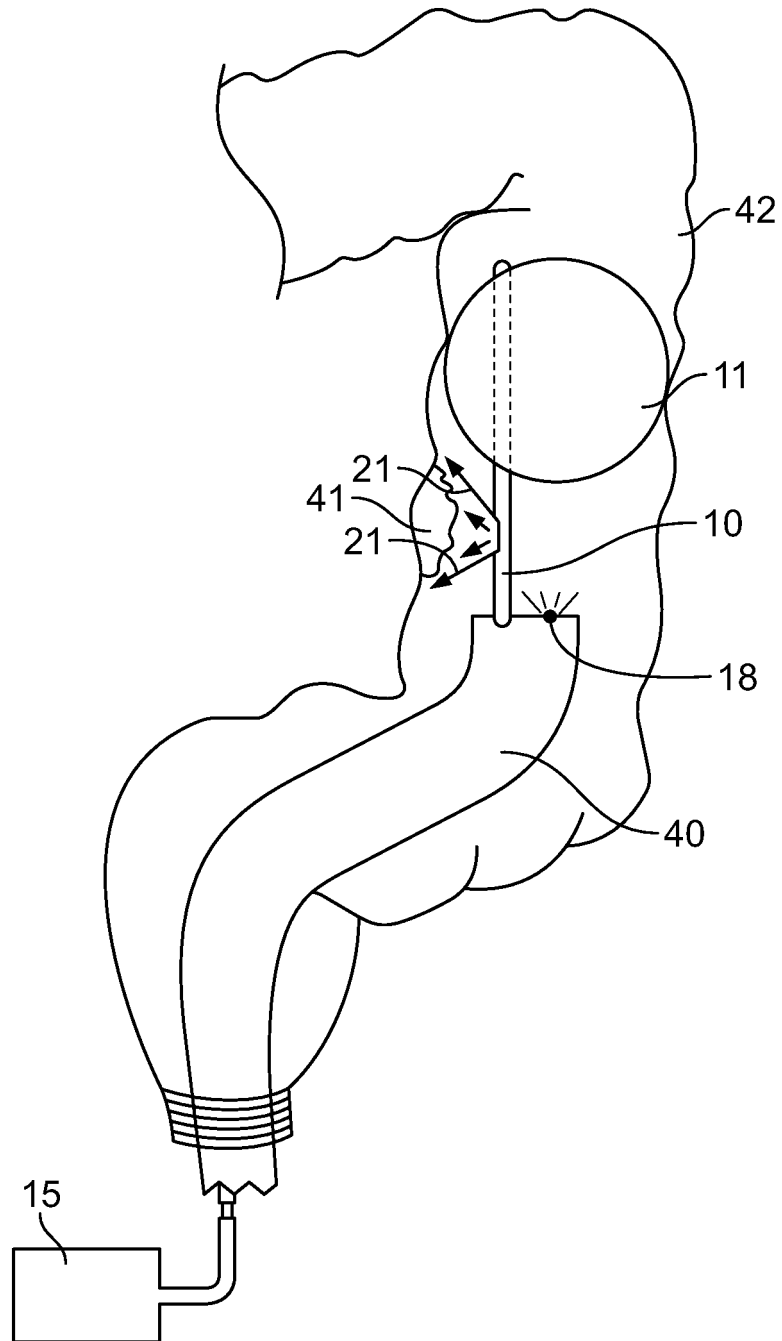

FIG. 4A

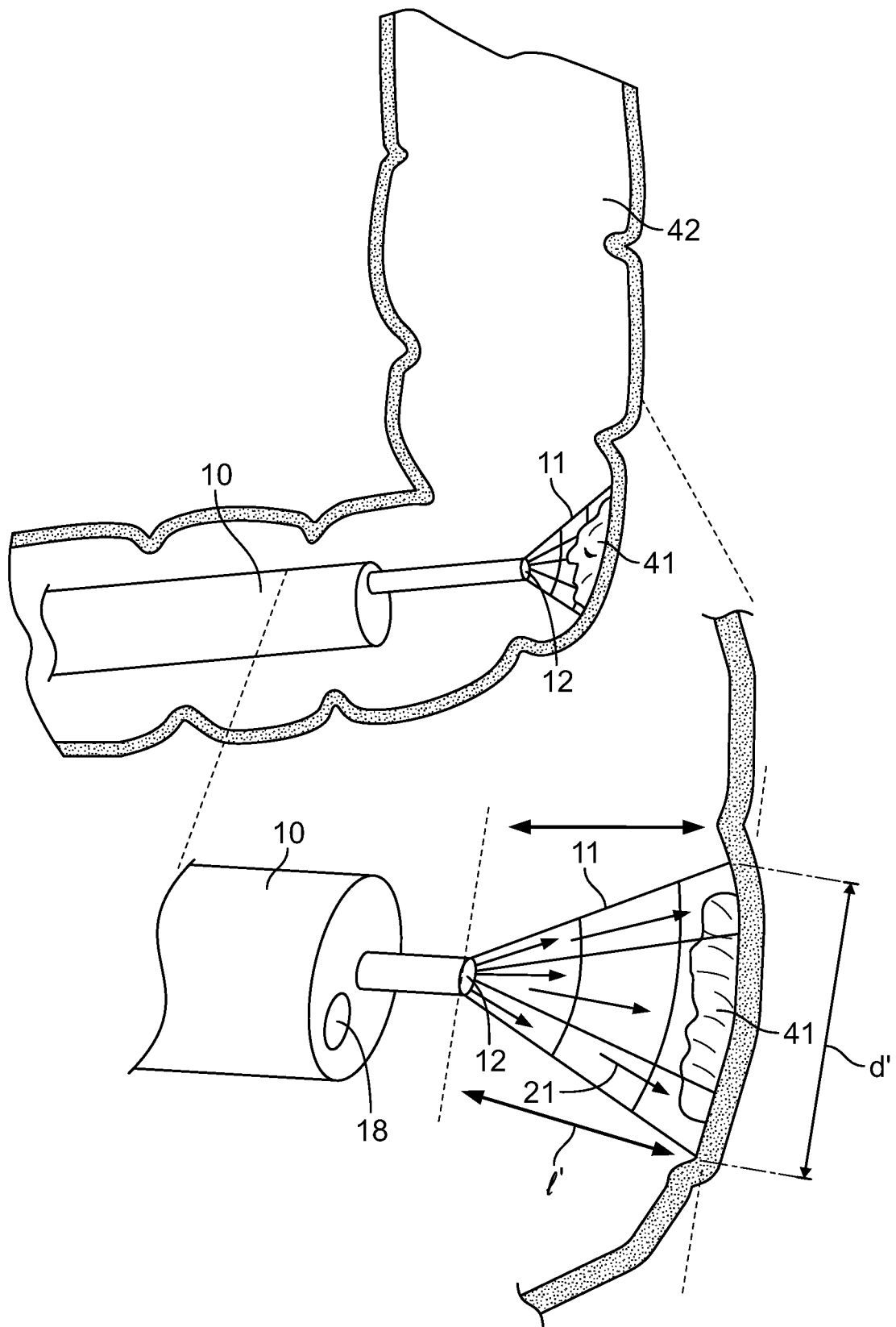

FIG. 4B

FIG. 5A

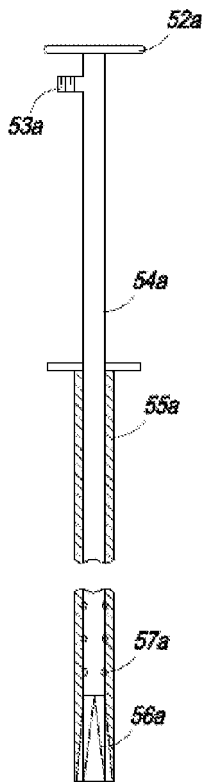

FIG. 5B

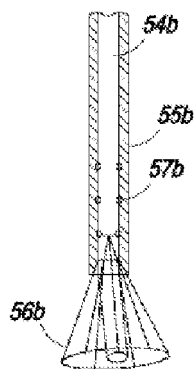

FIG. 5C

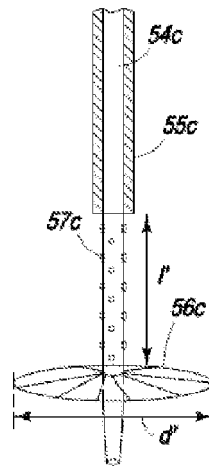

FIG. 5D

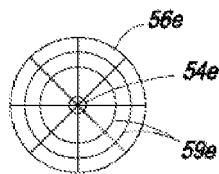
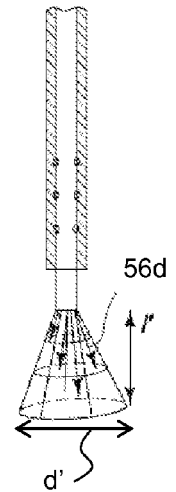

FIG. 5E

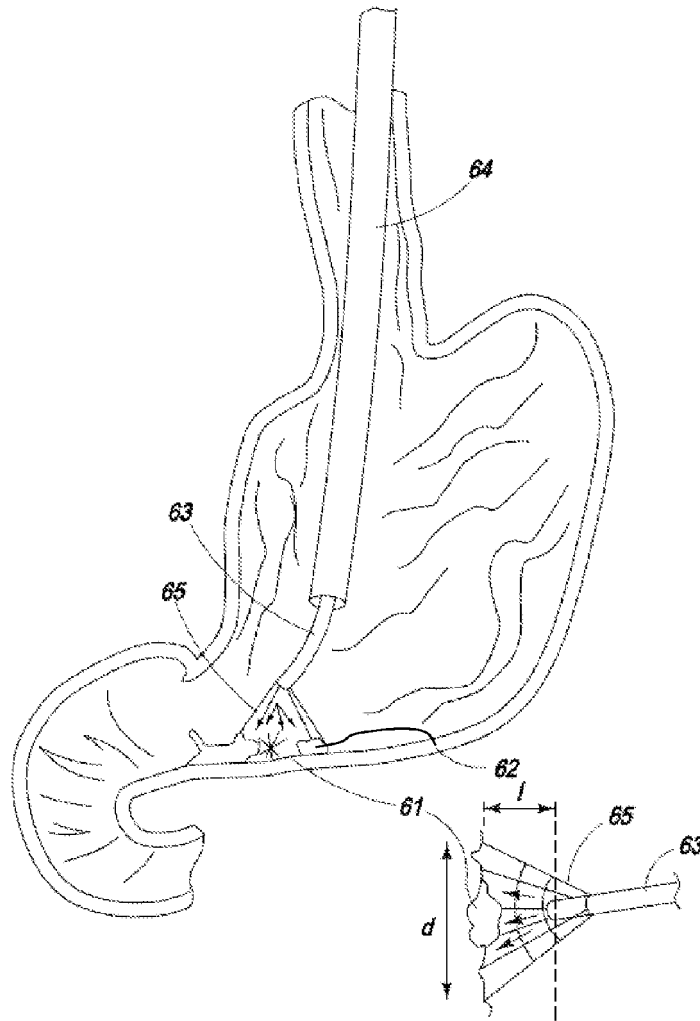

FIG. 6

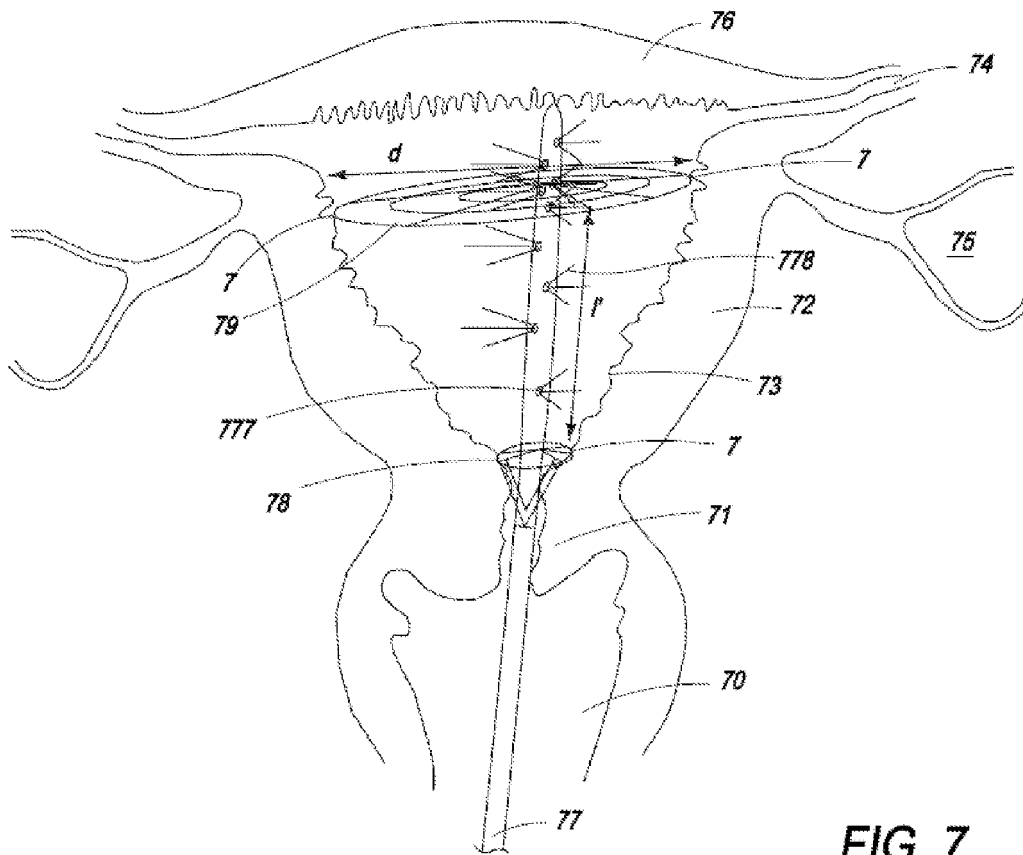

FIG. 7

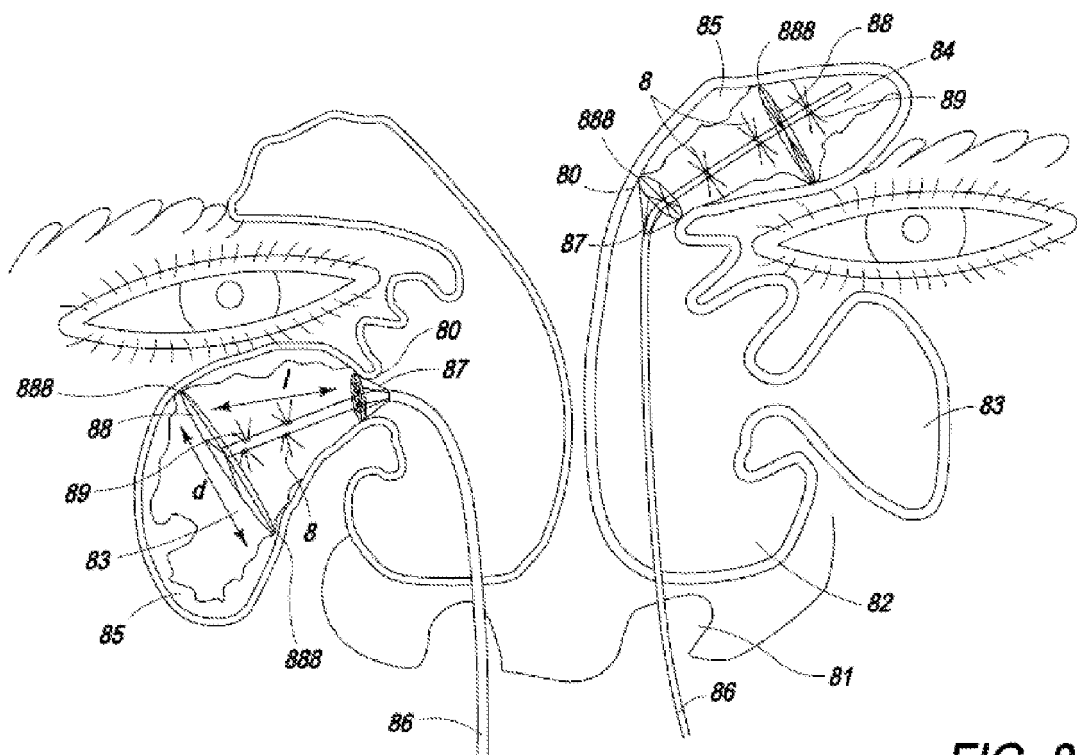

FIG. 8

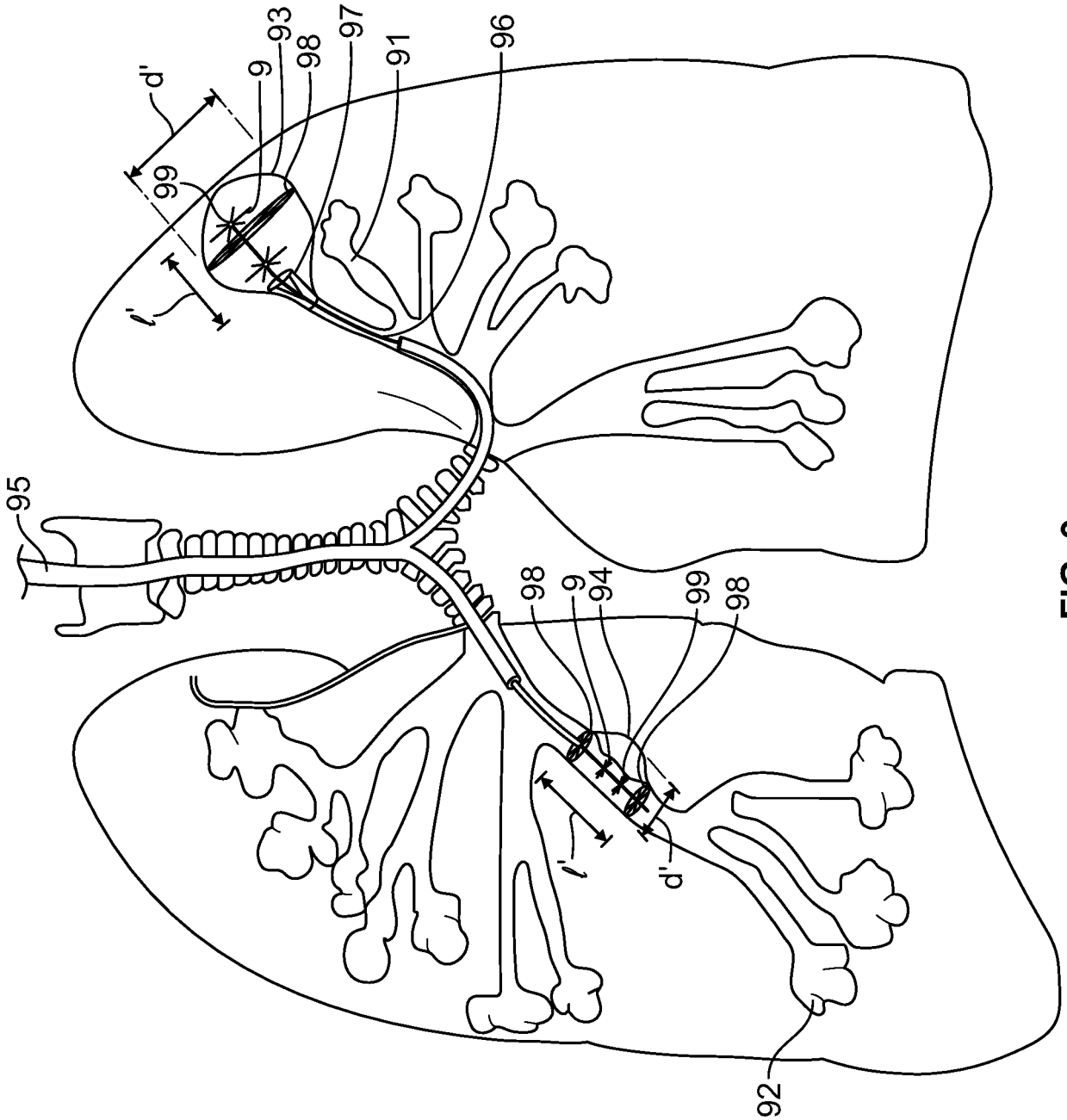

FIG. 9

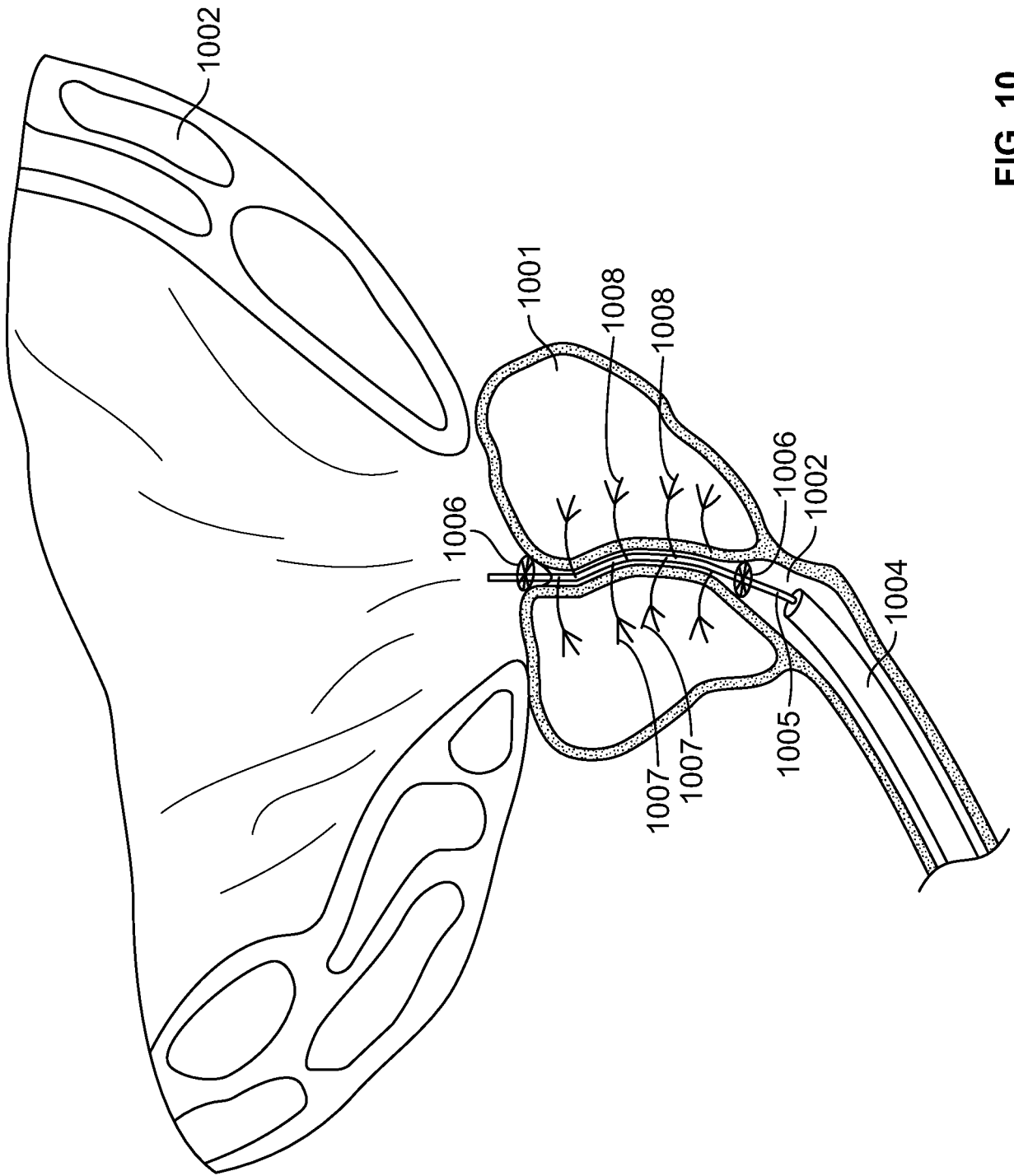

FIG. 10

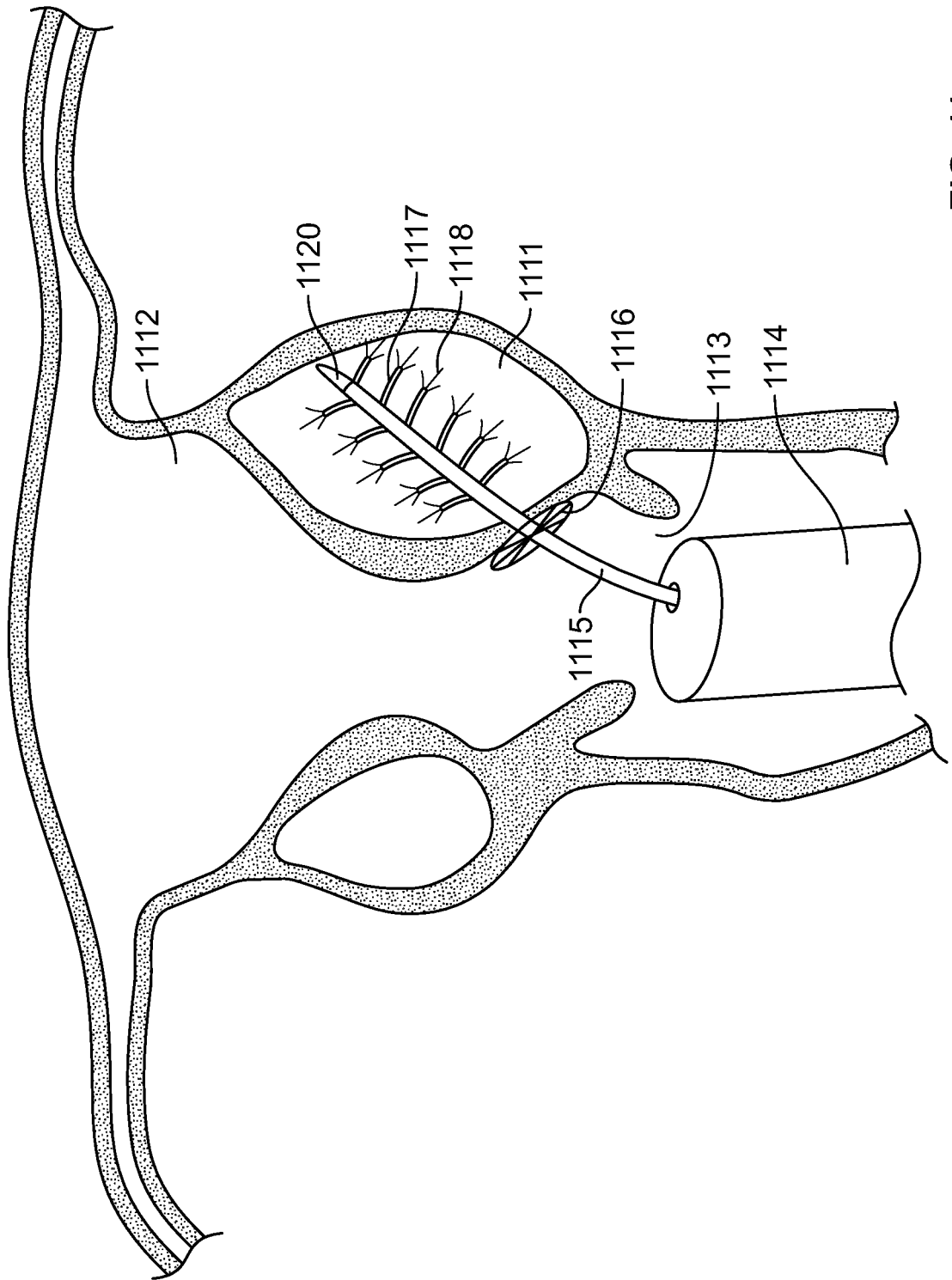

FIG. 11

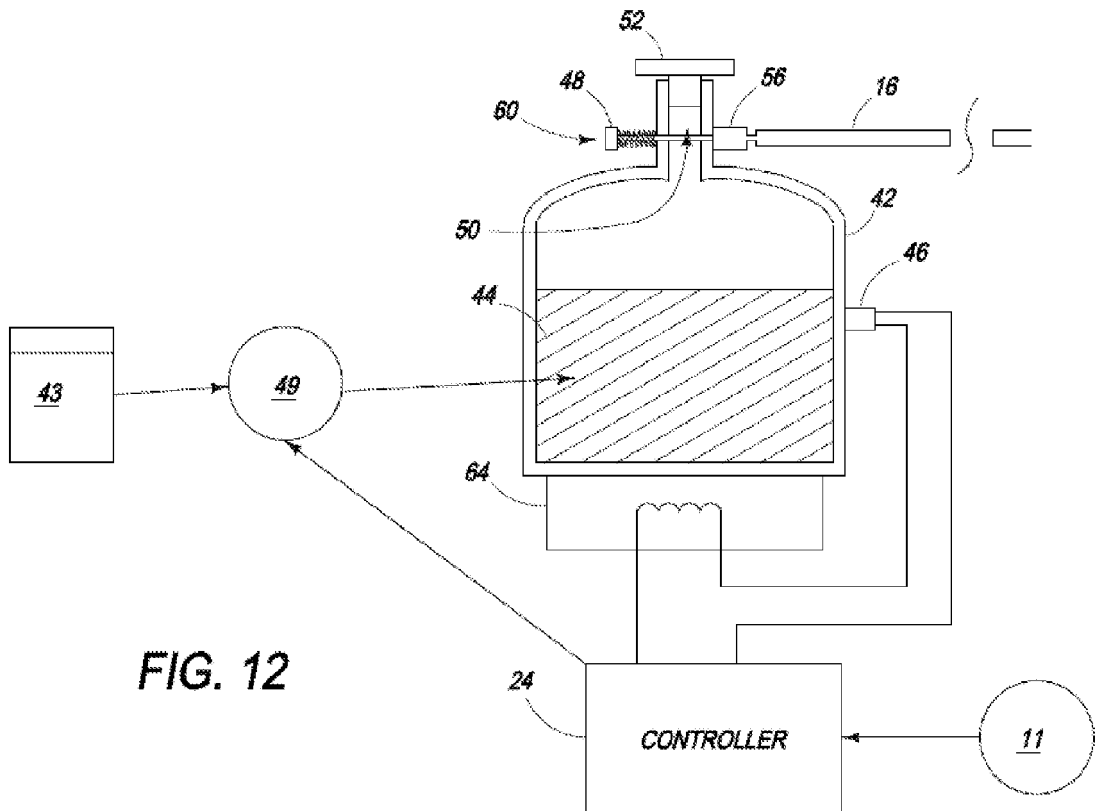

FIG. 12

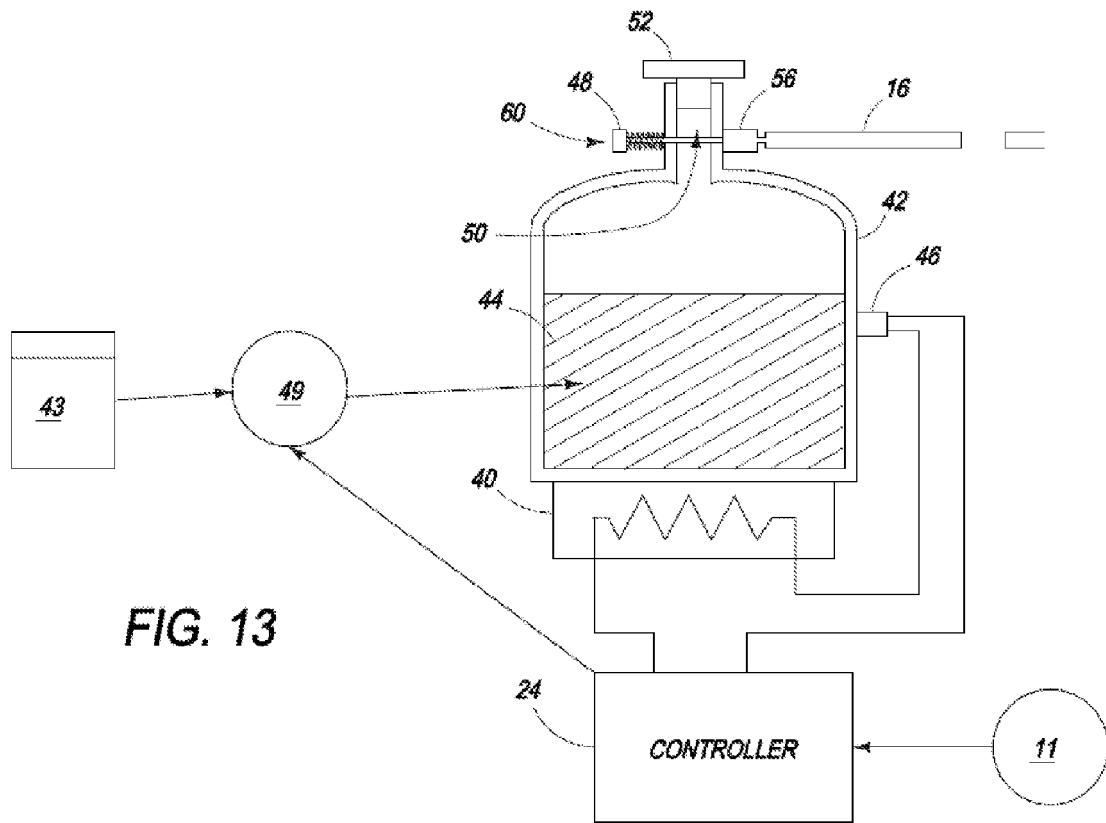

FIG. 13

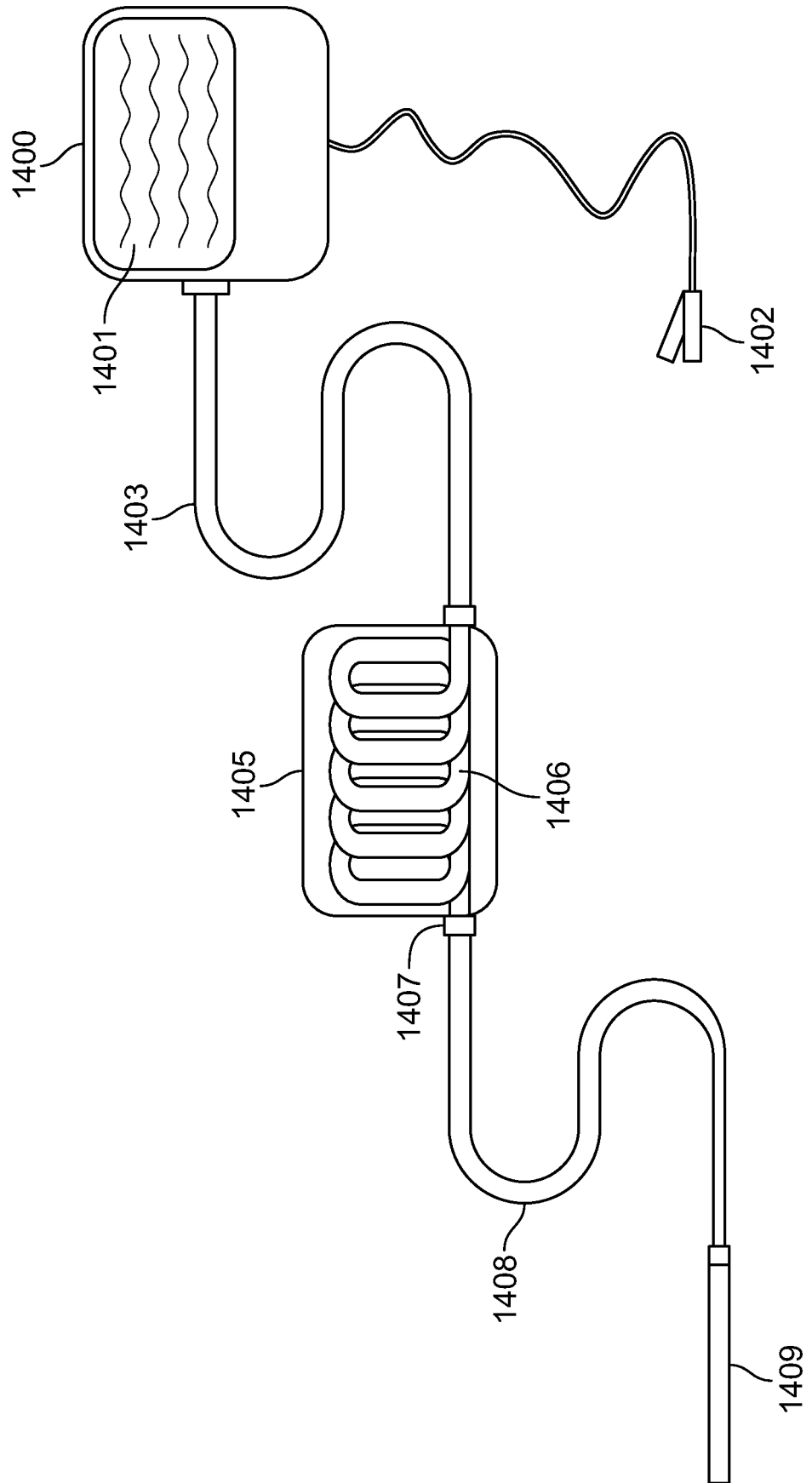

FIG. 14

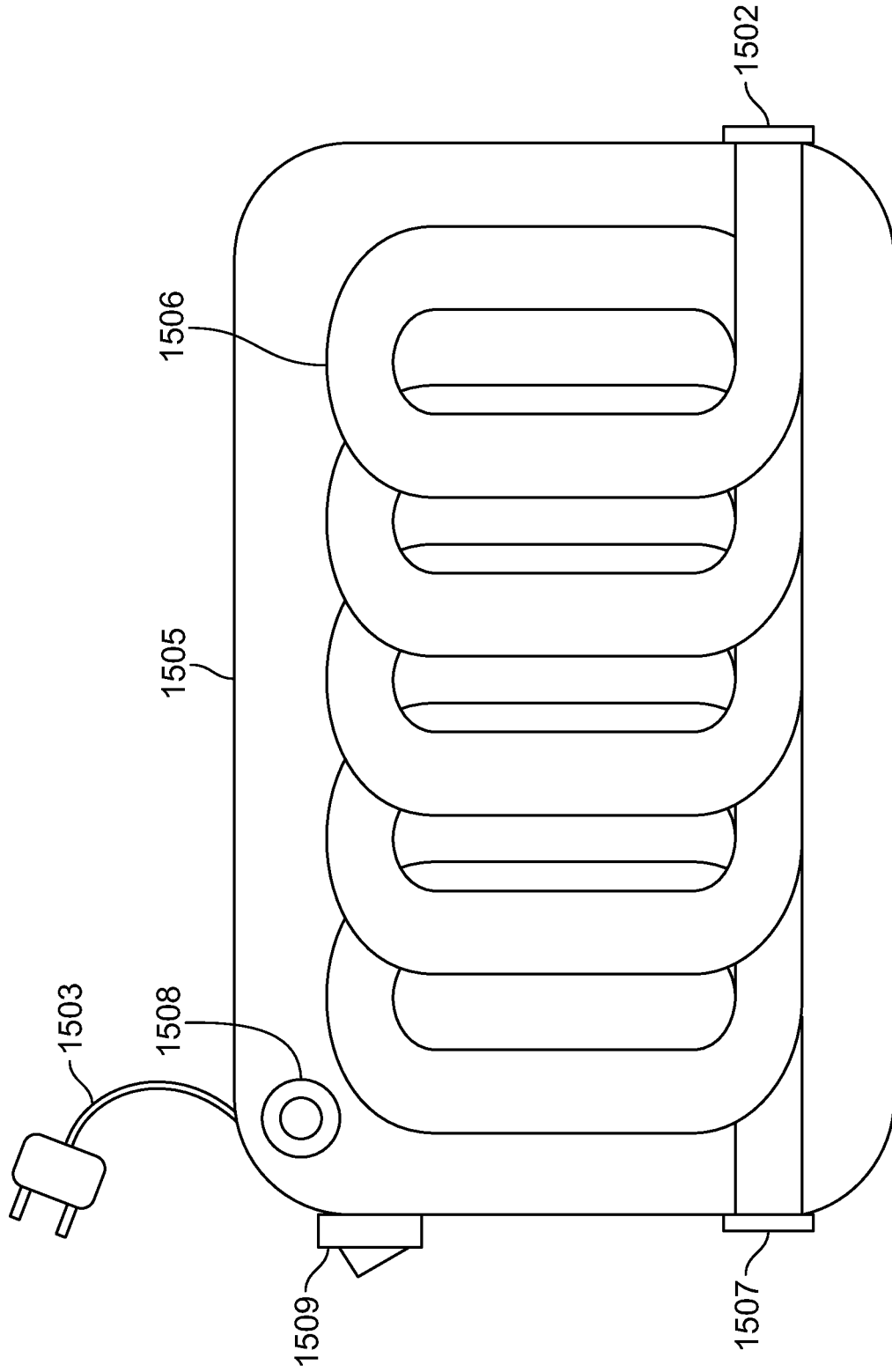

FIG. 15

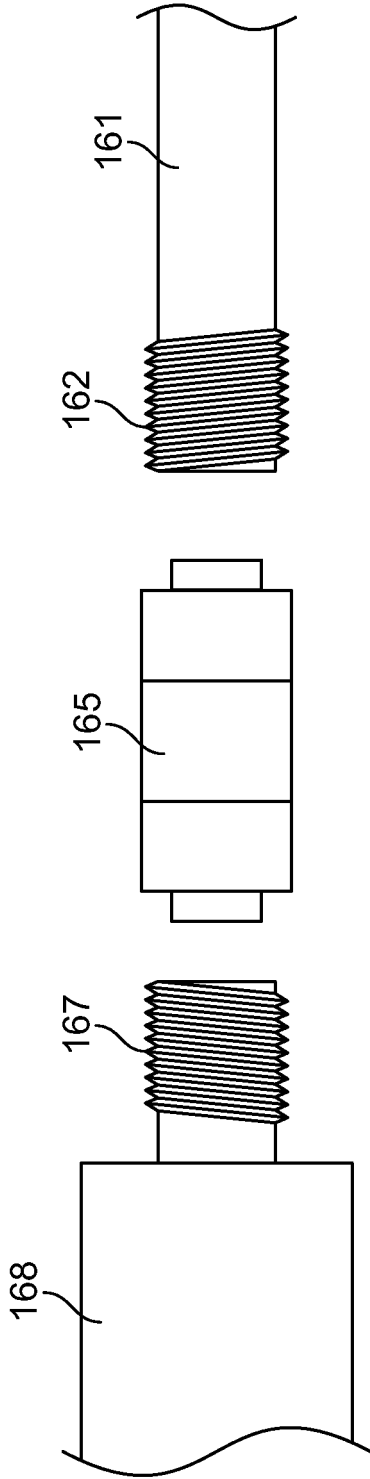

FIG. 16A

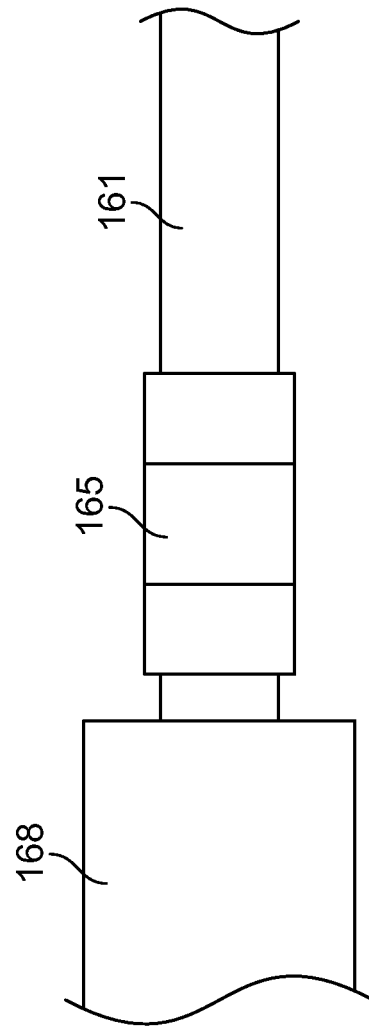

FIG. 16B

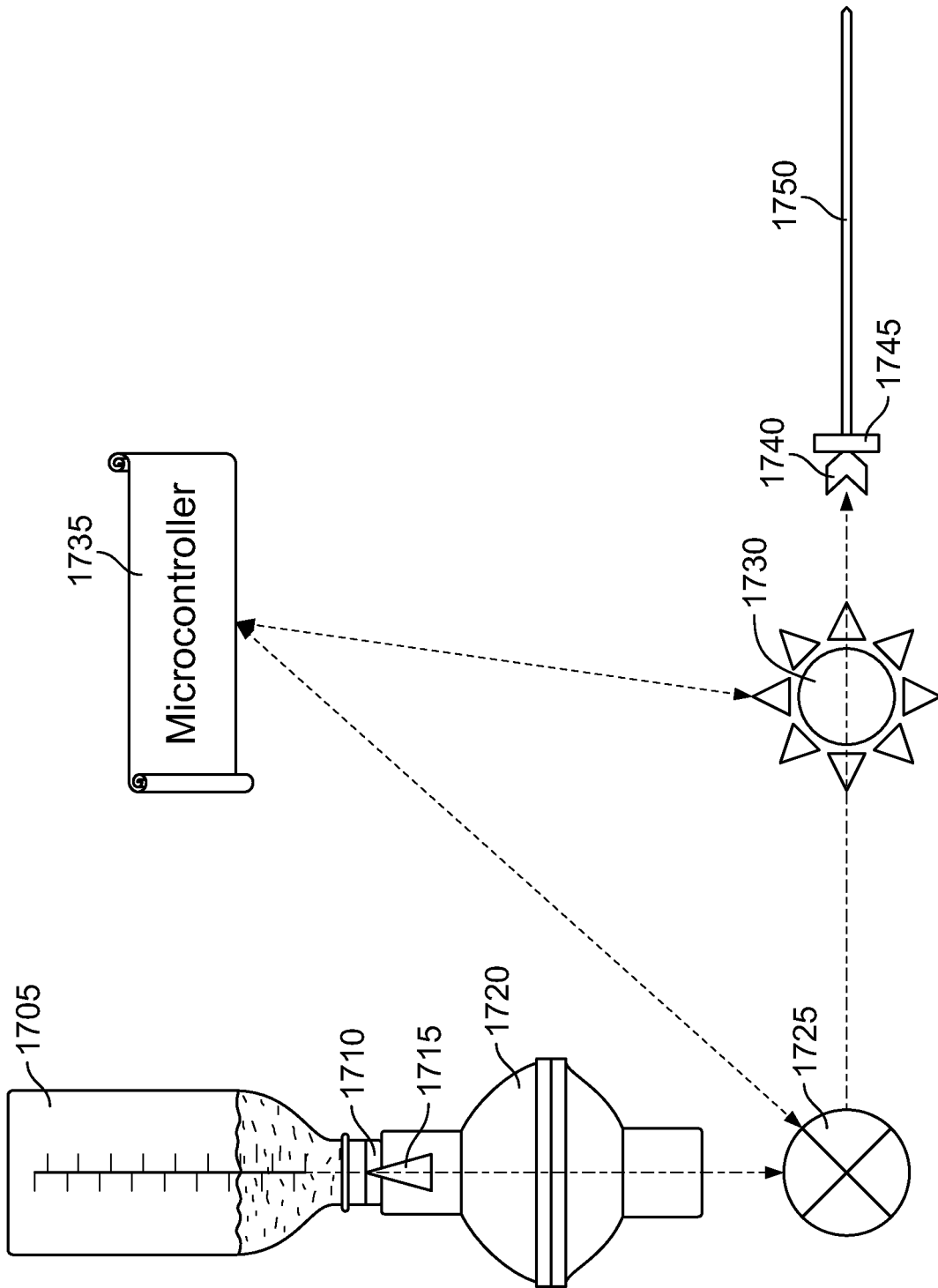

FIG. 17

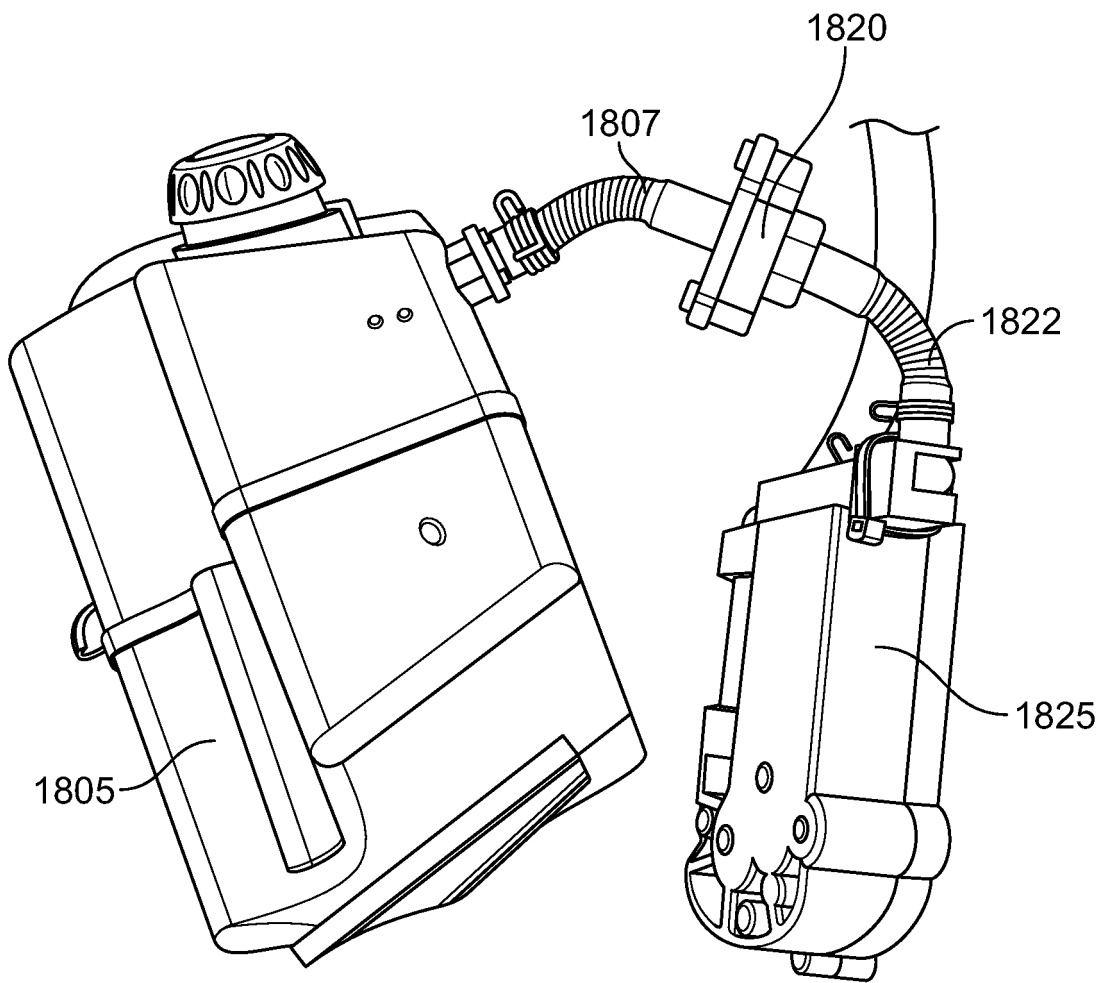

FIG. 18

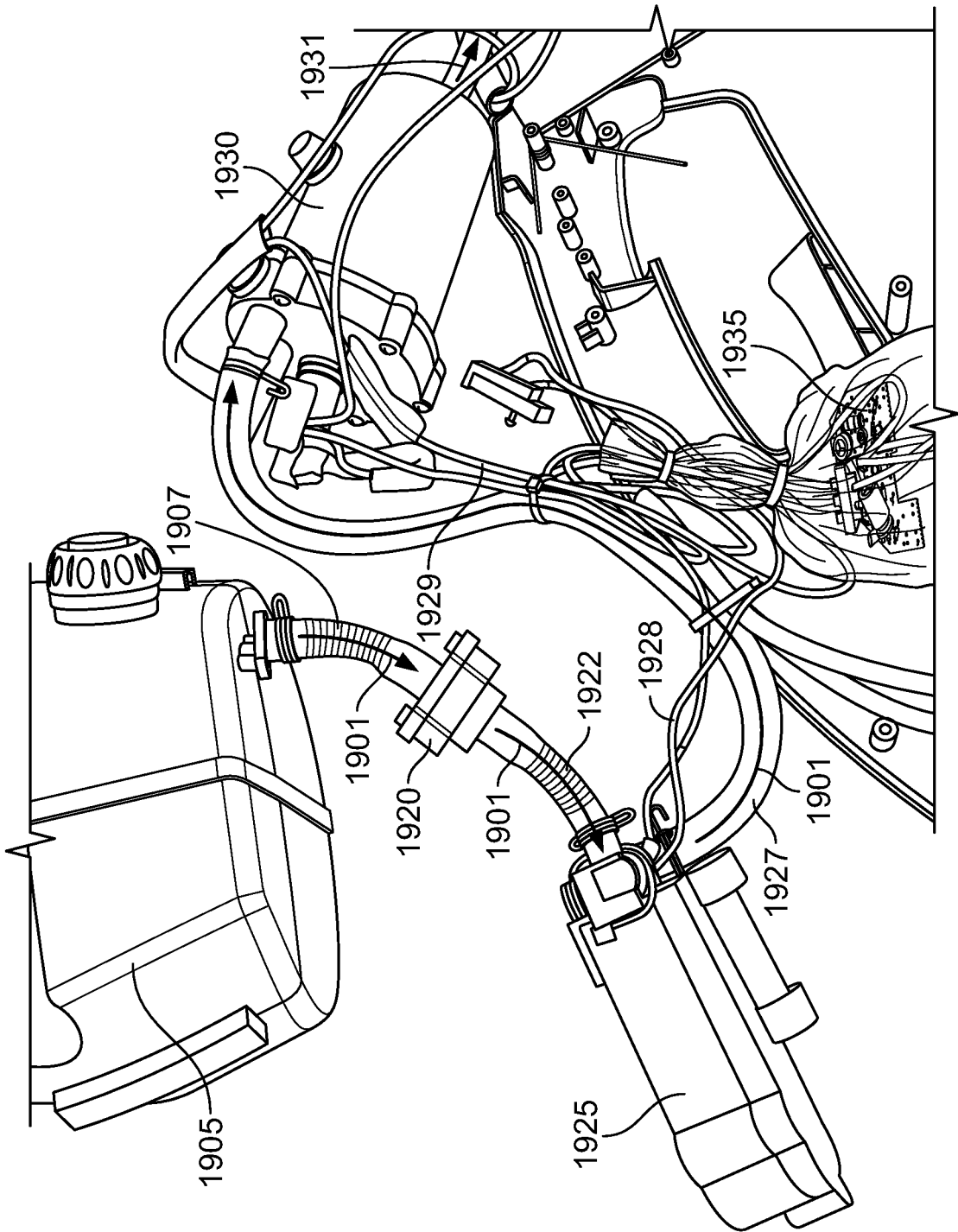

FIG. 19

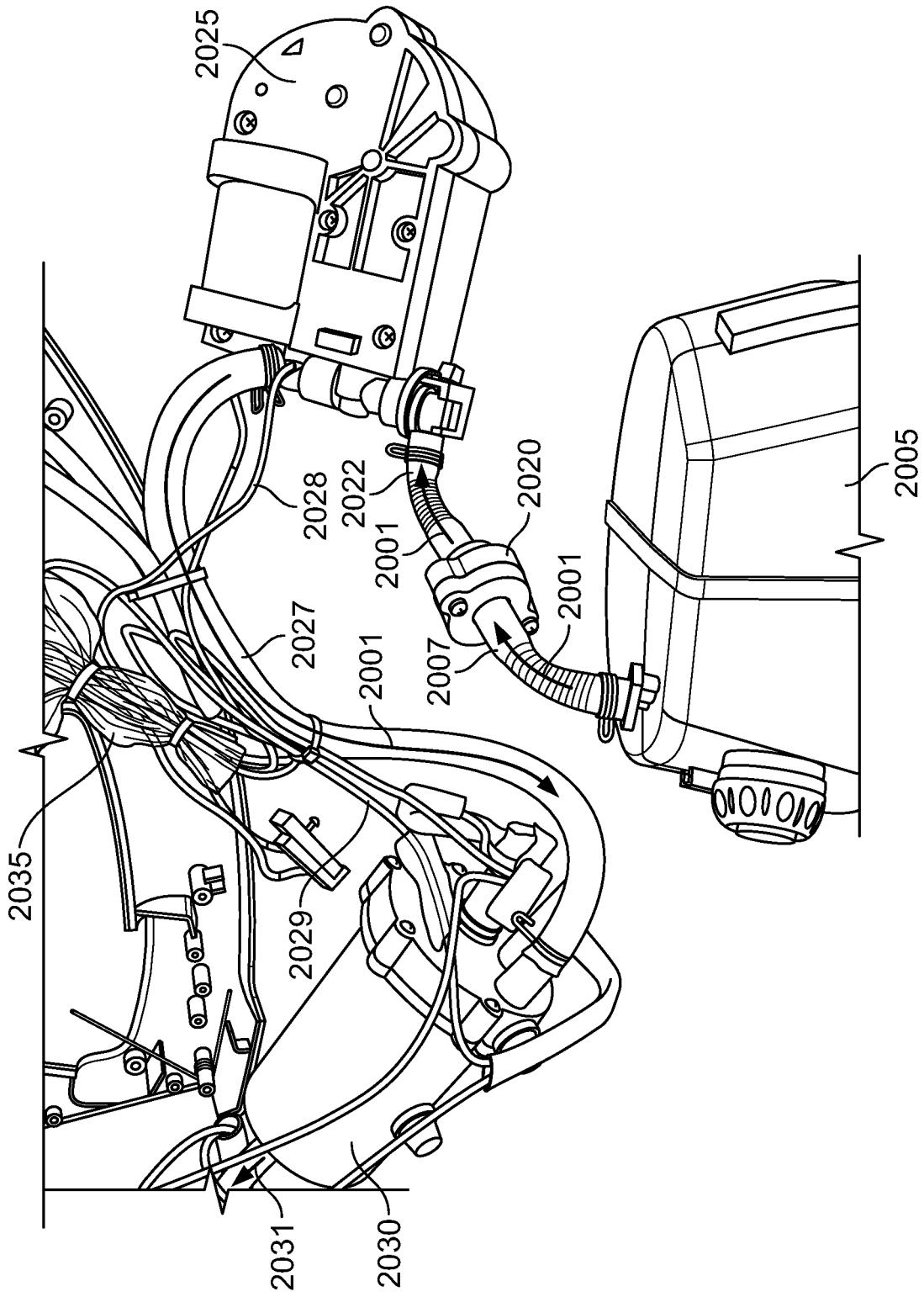

FIG. 20

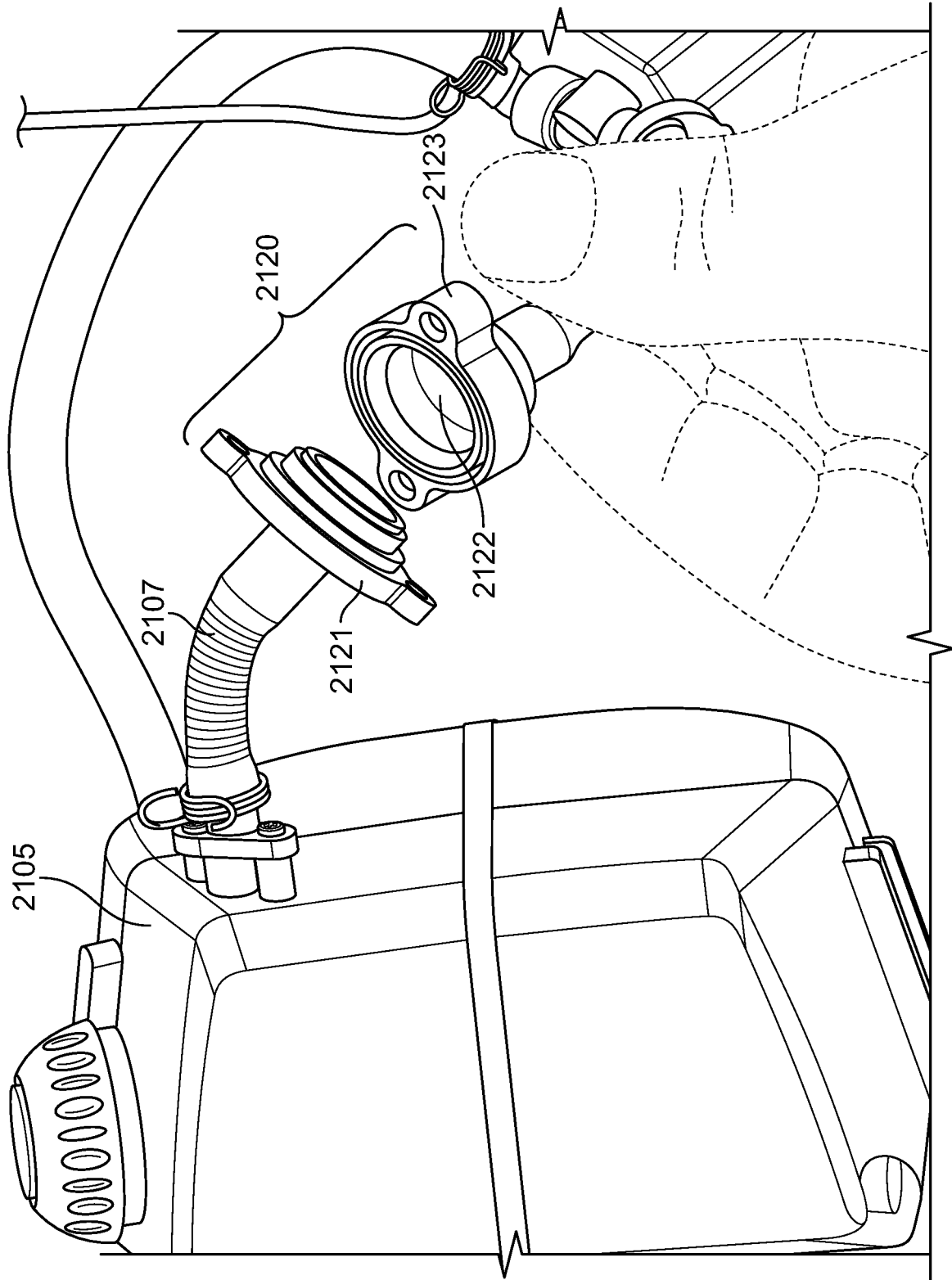

FIG. 21

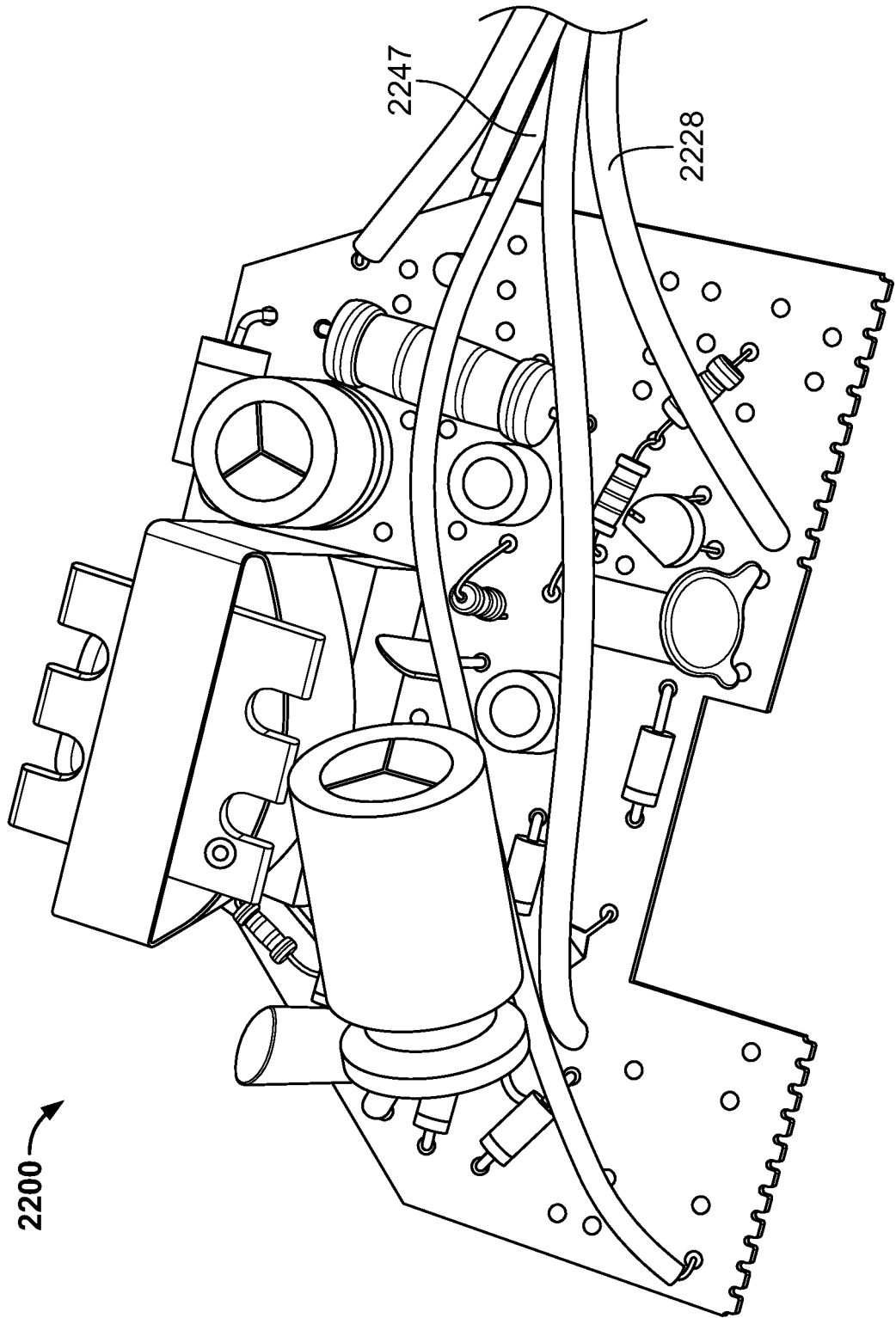

FIG. 22

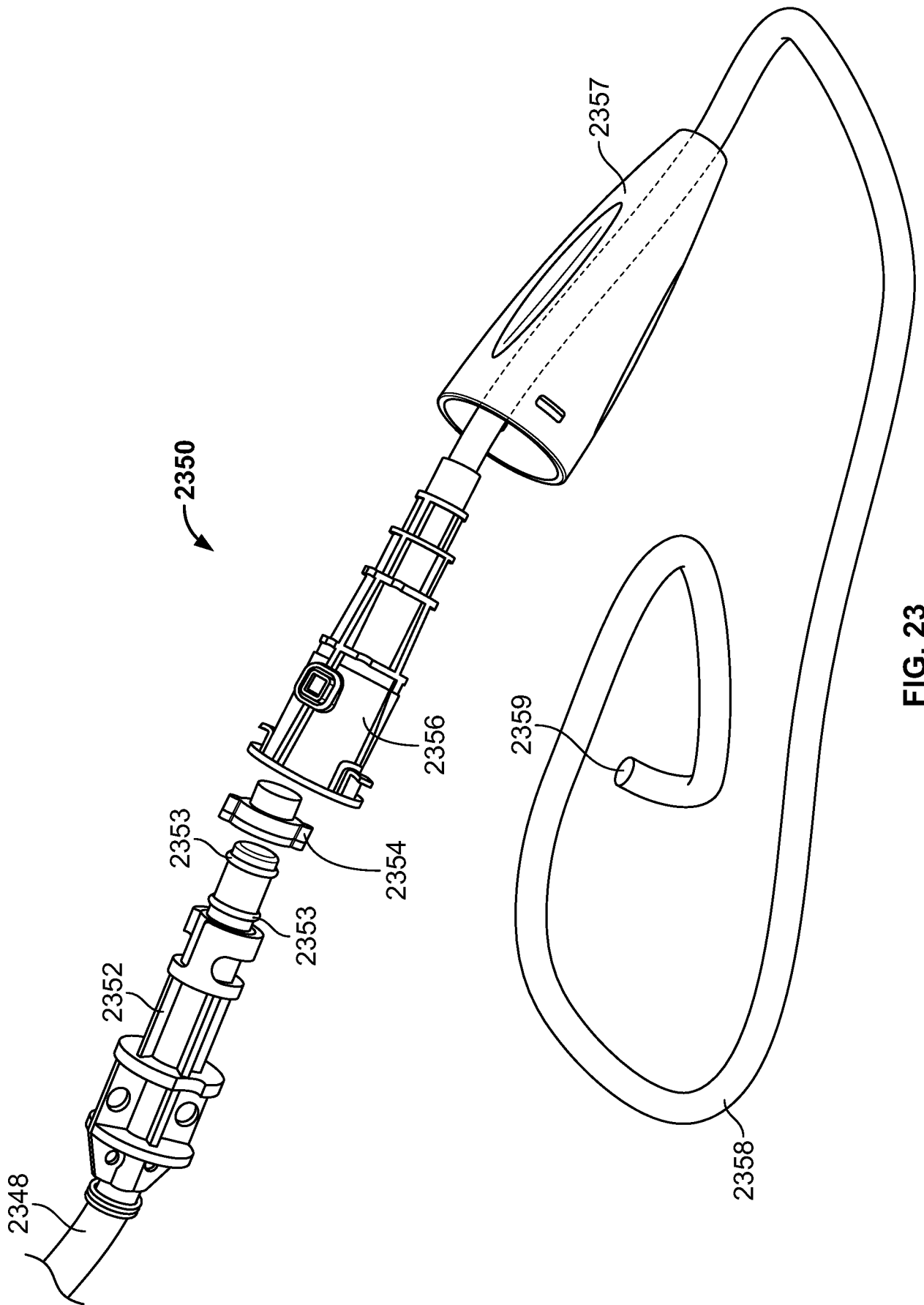

FIG. 23

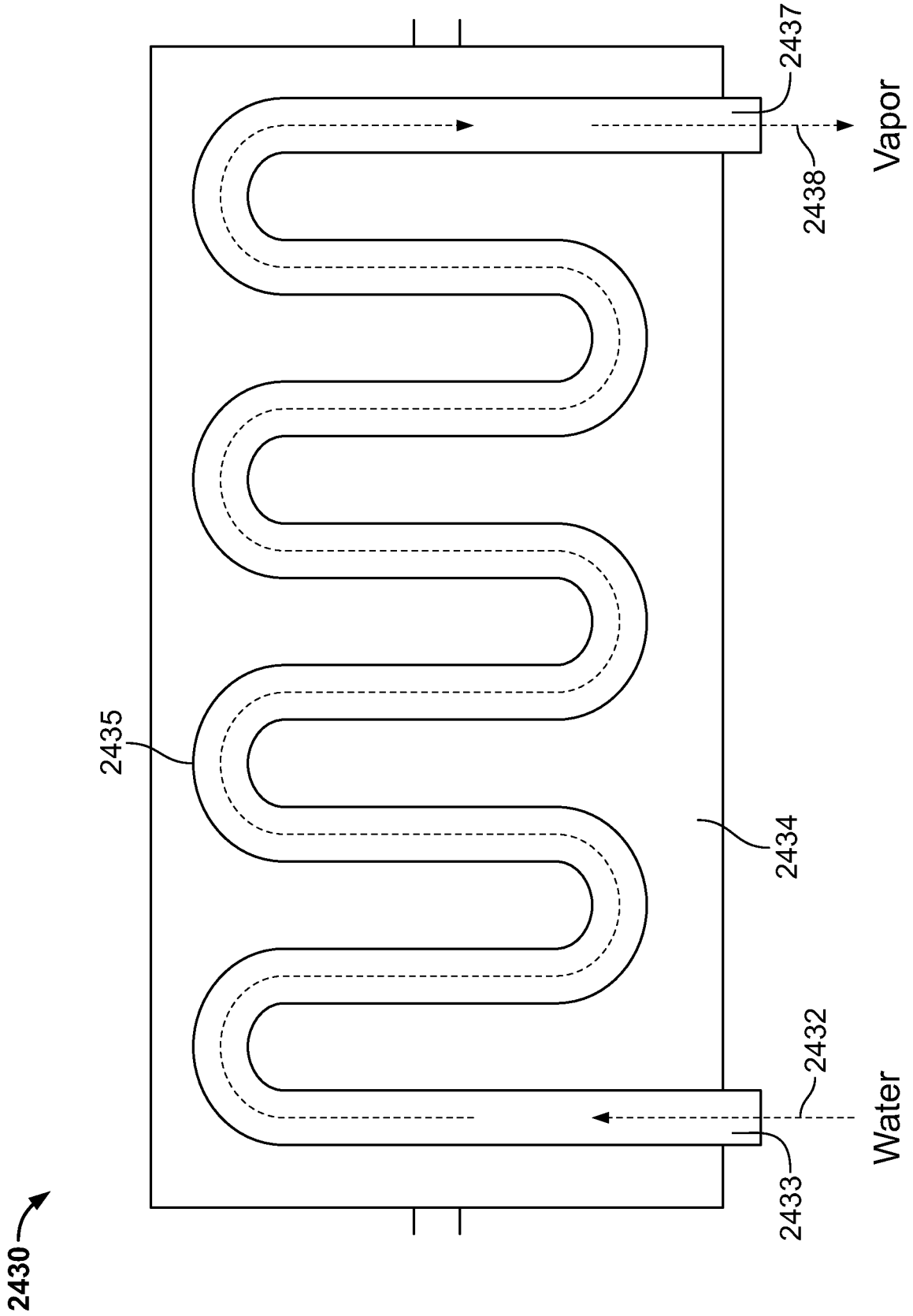

FIG. 24

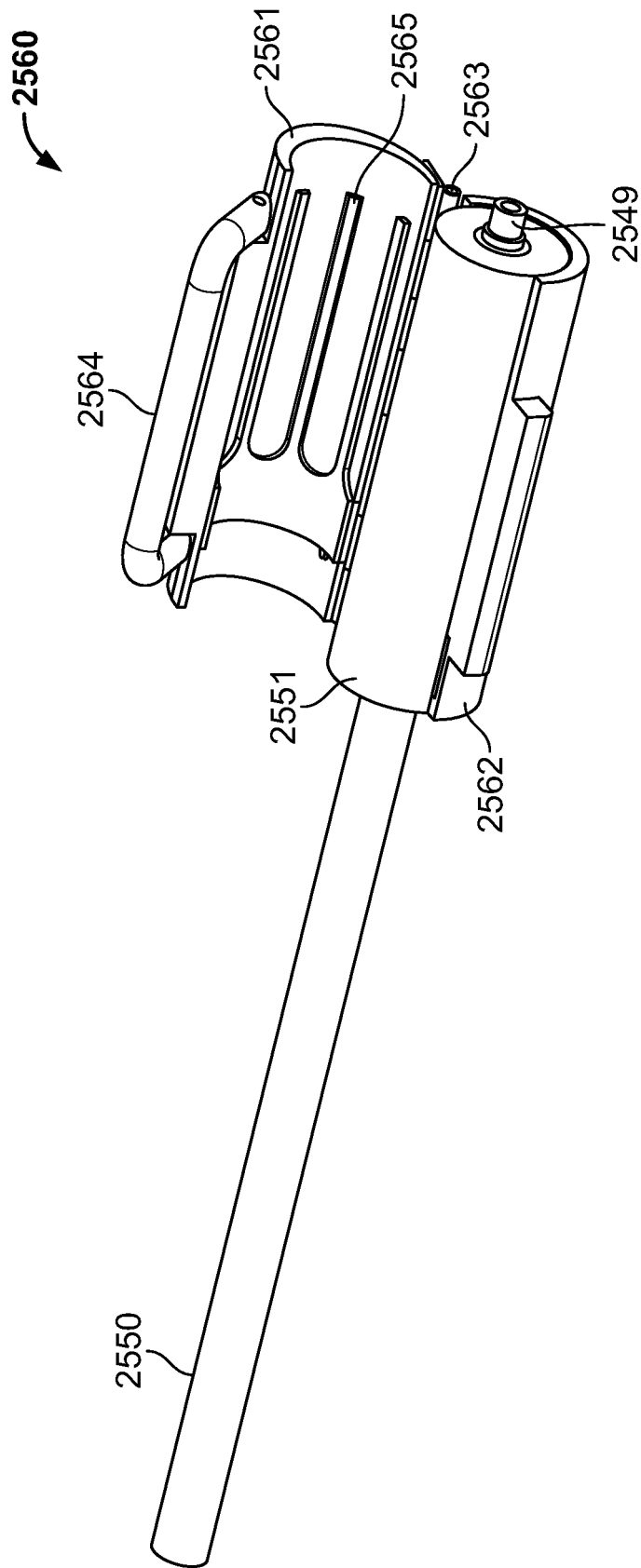

FIG. 25

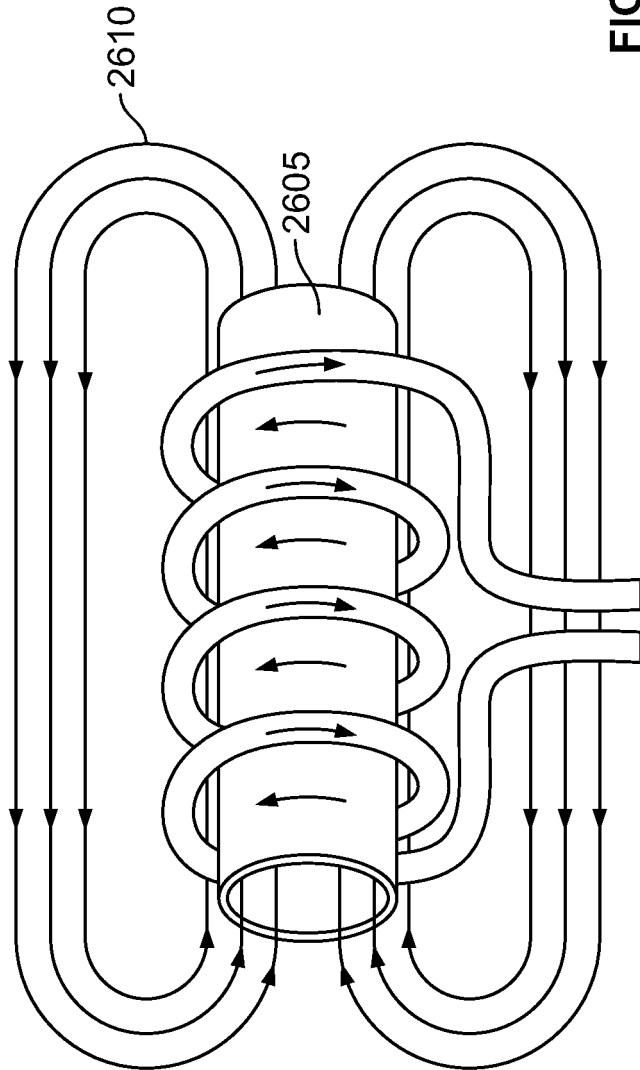

FIG. 26

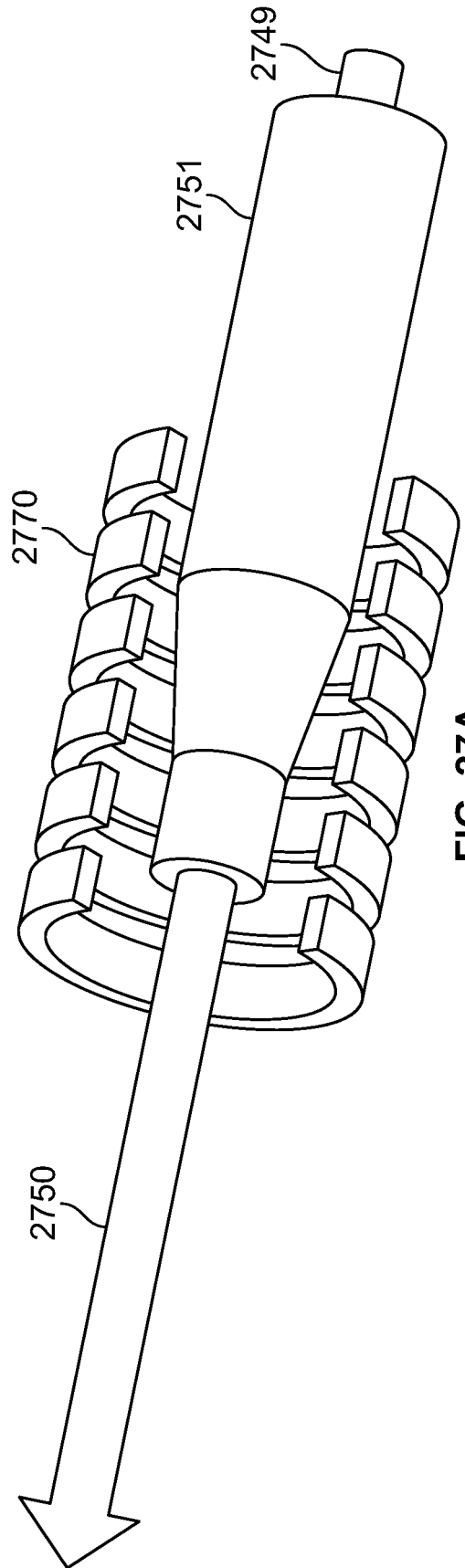

FIG. 27A

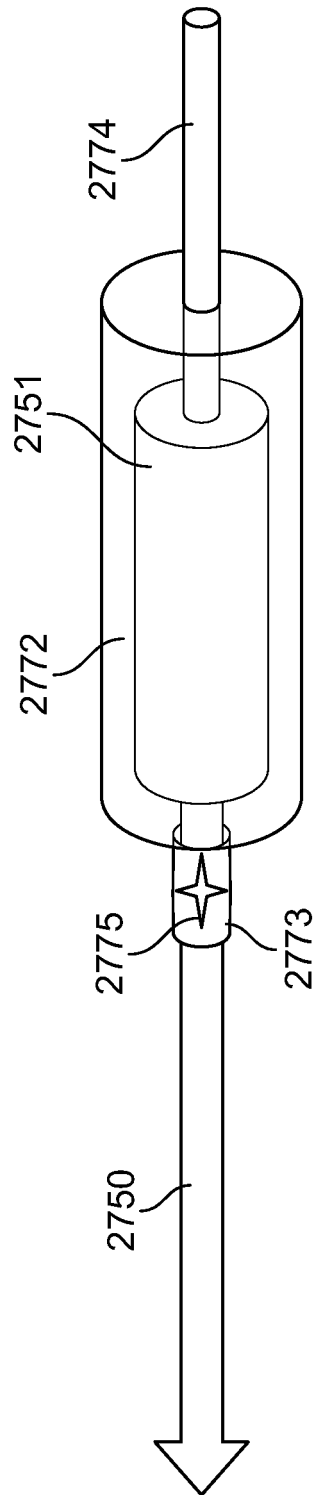

FIG. 27B

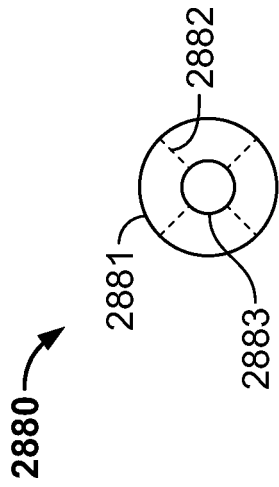

FIG. 28A

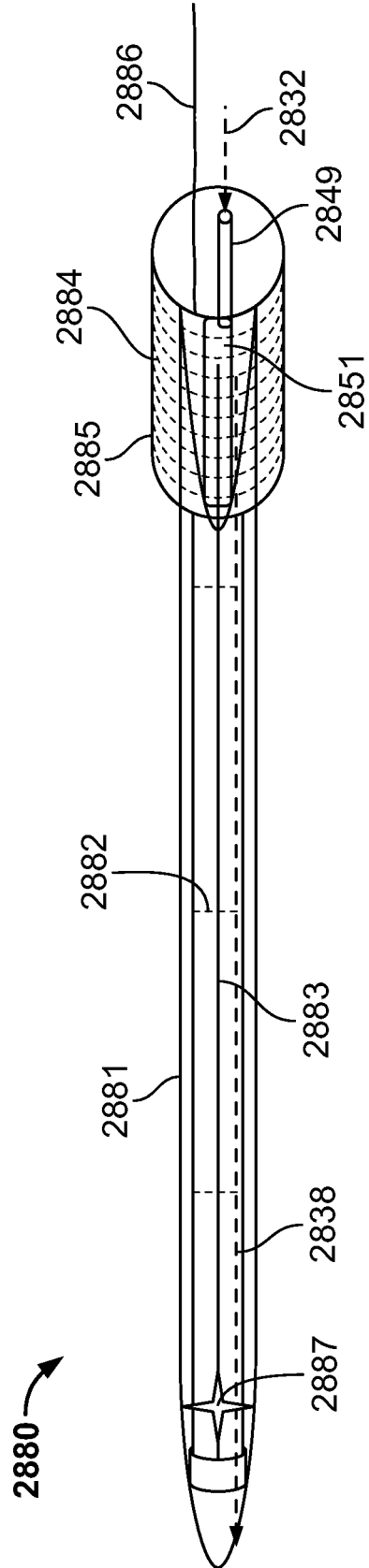

FIG. 28B

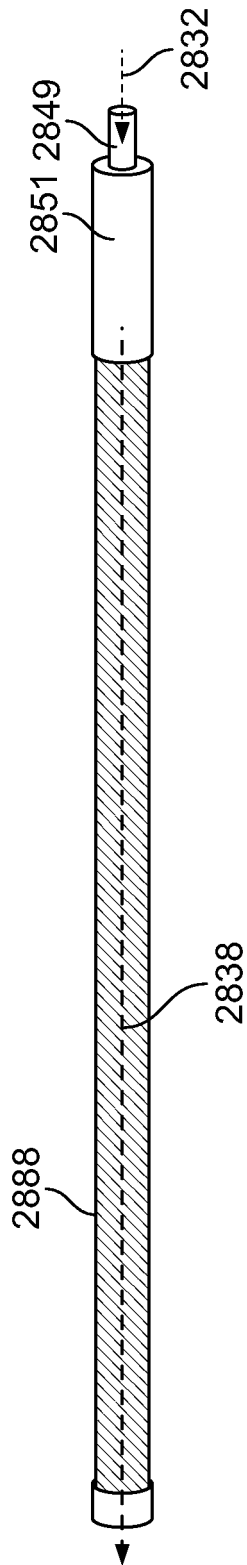

FIG. 28C

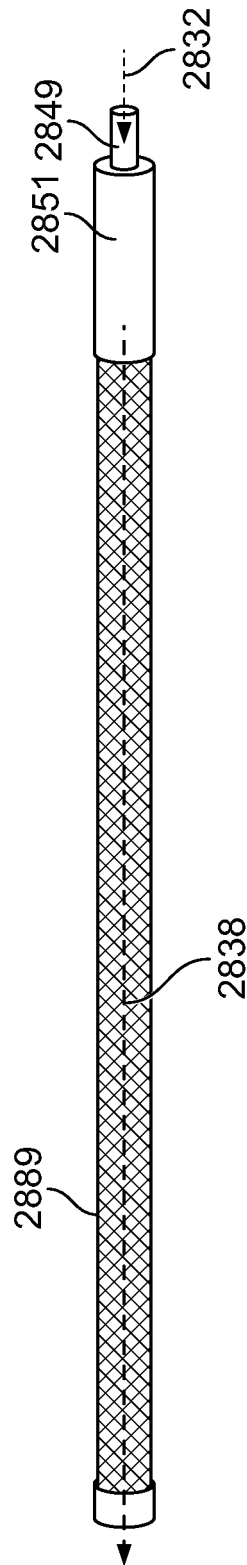

FIG. 28D

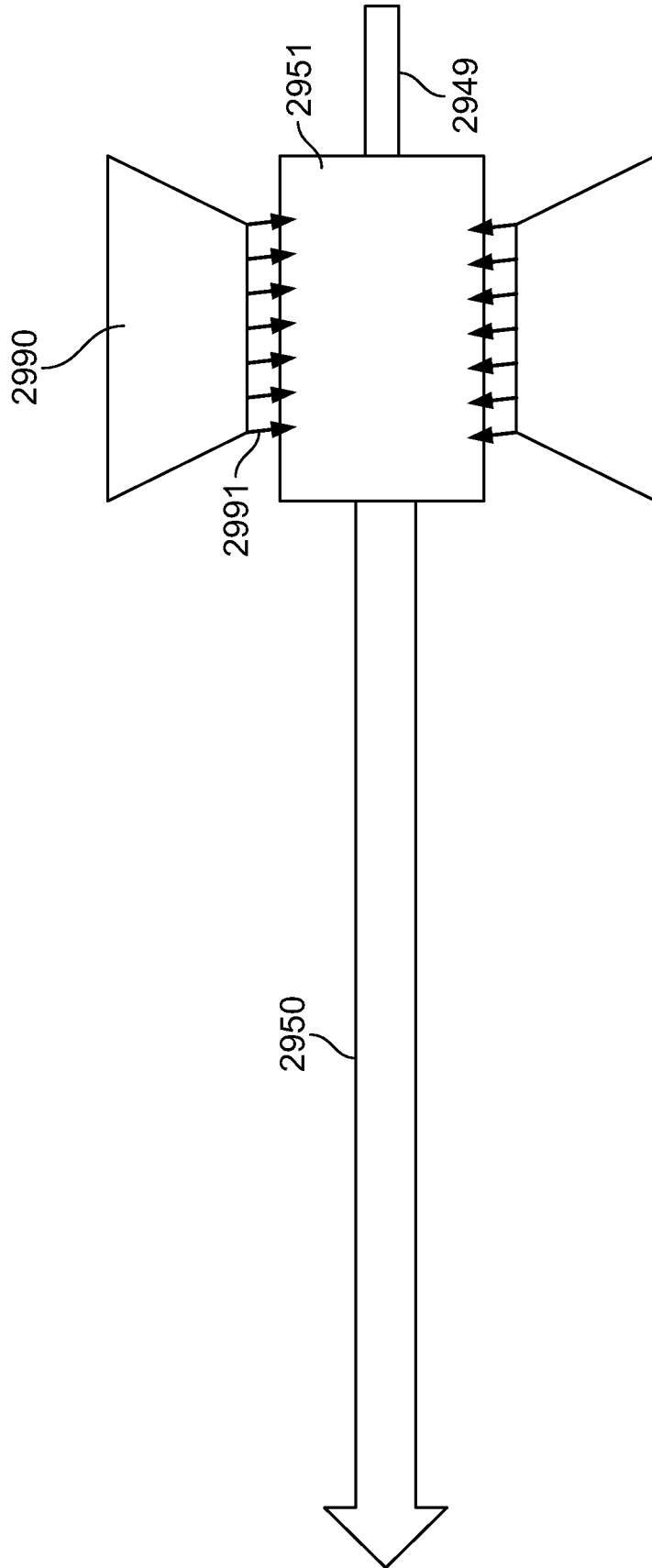

FIG. 29

专利名称(译)	用于组织消融的方法和设备		
公开(公告)号	EP2713923A4	公开(公告)日	2014-10-29
申请号	EP2012793307	申请日	2012-06-03
[标]申请(专利权)人(译)	SHARMA VIRENDER K.		
申请(专利权)人(译)	夏尔马VIRENDER K.		
当前申请(专利权)人(译)	夏尔马VIRENDER K.		
[标]发明人	SHARMA VIRENDER K		
发明人	SHARMA, VIRENDER K.		
IPC分类号	A61B18/04 A61B5/00 A61B5/107 A61B17/00 A61B17/24 A61B17/42 A61B18/00 A61B19/00 A61M25/10		
CPC分类号	A61B18/04 A61B5/1076 A61B5/6853 A61B17/24 A61B2017/00084 A61B2017/00203 A61B2017/00809 A61B2017/00973 A61B2017/4216 A61B2018/00327 A61B2018/00488 A61B2018/00494 A61B2018/00541 A61B2018/00547 A61B2018/00559 A61B2018/00577 A61B2018/00642 A61B2018/00648 A61B2018/00714 A61B2018/00744 A61B2018/00791 A61B2018/048 A61B2090/064 A61M25/04 A61M25/1011 A61M2205/3368		
优先权	61/493344 2011-06-03 US		
其他公开文献	EP2713923A2		
外部链接	Espacenet		

摘要(译)

本申请公开了消融人体组织的装置。该装置包括具有轴的导管，消融剂可以通过该轴移动，液体储存器和加热部件，其可以包括一段包含在加热元件内的盘管，其中所述加热元件的激活导致所述盘管增加从第一温度到第二温度，并且其中增加导致连续油管内的液体转换成蒸汽，将储存器的出口连接到加热部件的入口的可重复使用的绳索，以及连接压力的单个使用的绳索 - 基于蒸汽的消融装置的抵抗入口到加热部件的出口。