



- (51) **International Patent Classification:**
A61B 5/00 (2006.01) *A61B 5/053* (2006.01)
- (21) **International Application Number:**
PCT/CH2009/000122
- (22) **International Filing Date:**
17 April 2009 (17.04.2009)
- (25) **Filing Language:** English
- (26) **Publication Language:** English
- (71) **Applicant (for all designated States except US): SOLIANIS HOLDING AG** [CH/CH]; c/o ATC (Switzerland) SARL, Zweigniederlassung Zug, Bahnhofstrasse 28, CH-6300 Zug (CH).
- (72) **Inventors; and**
- (75) **Inventors/Applicants (for US only): CADUFF, Andreas** [CH/CH]; Giessereistrasse 14, CH-8005 Zürich (CH). **TALARY, Mark, Stuart** [CH/CH]; Grossackerstrasse 79, CH-8041 Zürich (CH). **MÜLLER, Martin** [CH/CH]; Federnstrasse 4, CH-8052 Zürich (CH). **DE FEO, Oscar** [IT/CH]; Rue Grand Saint Jean 4, CH-1003 Lausanne (CH).
- (74) **Agent: E. BLUM & CO. AG;** Vorderberg 11, CH-8044 Zürich (CH).

- (81) **Designated States (unless otherwise indicated, for every kind of national protection available):** AE, AG, AL, AM, AO, AT, AU, AZ, BA, BB, BG, BH, BR, BW, BY, BZ, CA, CH, CN, CO, CR, CU, CZ, DE, DK, DM, DO, DZ, EC, EE, EG, ES, FI, GB, GD, GE, GH, GM, GT, HN, HR, HU, ID, IL, IN, IS, JP, KE, KG, KM, KN, KP, KR, KZ, LA, LC, LK, LR, LS, LT, LU, LY, MA, MD, ME, MG, MK, MN, MW, MX, MY, MZ, NA, NG, NI, NO, NZ, OM, PG, PH, PL, PT, RO, RS, RU, SC, SD, SE, SG, SK, SL, SM, ST, SV, SY, TJ, TM, TN, TR, TT, TZ, UA, UG, US, UZ, VC, VN, ZA, ZM, ZW.
- (84) **Designated States (unless otherwise indicated, for every kind of regional protection available):** ARIPO (BW, GH, GM, KE, LS, MW, MZ, NA, SD, SL, SZ, TZ, UG, ZM, ZW), Eurasian (AM, AZ, BY, KG, KZ, MD, RU, TJ, TM), European (AT, BE, BG, CH, CY, CZ, DE, DK, EE, ES, FI, FR, GB, GR, HR, HU, IE, IS, IT, LT, LU, LV, MC, MK, MT, NL, NO, PL, PT, RO, SE, SI, SK, TR), OAPI (BF, BJ, CF, CG, CI, CM, GA, GN, GQ, GW, ML, MR, NE, SN, TD, TG).

Published:

— with international search report (Art. 21(3))

(54) **Title:** WIDE BAND FIELD RESPONSE MEASUREMENT FOR GLUCOSE DETERMINATION

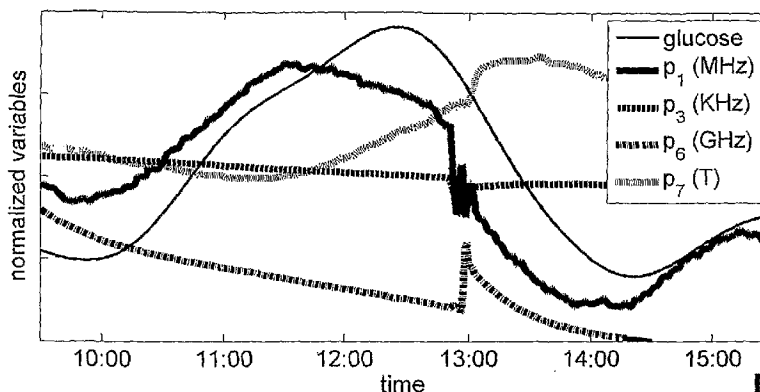

Fig. 5

(57) **Abstract:** A method and device for determining the glucose level in living tissue are based on measuring the response of the tissue an electric field as well as temperature measurements. In order to improve accuracy, it has been found that measurements in at least three frequency ranges between 1 kHz and 200 kHz, 0.2 MHz an 100 MHz as well as above 1 GHz should be combined since the response of the tissue in these different frequency ranges is ruled by differing mechanisms.

WO 2010/118538 A1

Wide band field response measurement for glucose determination

Technical Field

5 The invention relates to a device and method for determining the glucose level of living tissue. In particular, it relates to technologies that derive the glucose level from the response of the tissue to an applied electrical field.

Background Art

10 WO 02/069791 describes a device for determining the glucose level of living tissue. The device comprises an electrode arrangement mounted to a substrate, as well as a control unit adapted to determine the response of the tissue to the electric field generated by the electrodes. This type of device exploits the fact that the
15 glucose level affects the dielectric and electric response of the same.

Similarly, WO 2005/053523 and WO2005/053526 describe hardware and measurement methodology to be used in such a device.

20 Since glucose level is not the only state variable of the tissue that affects its electric and dielectric response, accuracy with such device can only be achieved by measuring and combining appropriate measured parameters.

Disclosure of the Invention

25 The problem to be solved by the present invention is therefore to provide an improved device and method of this type that allows a more accurate glucose level determination.

This problem is solved by the device and method of the independent claims.

30 Accordingly, AC signal voltages of at least a first, a second and a third frequency are applied, consecutively or simultaneously, to the electrode arrangement in order to measure a first, a second and a third electric parameter, respectively. The first frequency is between 1 kHz and 200 kHz, the second frequency is between 0.2 MHz and 100 MHz, and the third frequency is at least 1 GHz.

35 In addition, a temperature parameter indicative of the temperature of the tissue is measured.

The first, second and third electric parameter as well as the temperature parameter are then combined in order to derive the glucose level. For example, a sum of linear and/or quadratic terms of the first, second and third electric parameter and the temperature signal can be used, with coefficients obtained from calibration measurements.

This is based on the understanding that measurements in the three specific frequency ranges are advantageous in order to eliminate the influence of tissue state parameters other than glucose on the measured signals. For example, glucose mainly modulates the beta-dispersion in the frequency range 0.2 MHz to 100 MHz, and the effect of sweat can be eliminated because it primarily affects the signal in the frequency range between 1 kHz and 200 kHz, while it has a lesser effect on the signals at the other frequency ranges. Furthermore, the temperature of the tissue affects all the electrically measured parameters, therefore a direct temperature measurement allows to improve the accuracy further.]

Advantageously, in order to compensate for changes in the water content in the skin and underlying tissue, the third frequency should be between 1 GHz and 30 GHz because the dielectric response of water primarily affects the signal in this frequency range, while it has a lesser effect on the signals at the other frequency ranges.

In a further advantageous embodiment, the first electric parameter is measured by means of a first pair of electrodes designed as interdigital electrodes because the separation gap needs to be very small to allow measuring only surface effects, and the interdigital arrangement allows for a suitable large measurement surface.

The second electric parameter is best measured by means of a second pair of electrodes separated by a gap of at least 2 mm. This allows to generate a field reaching sufficiently far into the tissue in order to measure the beta-dispersion of blood in the tissue. Advantageously, at least two pairs of electrodes with different gap widths are provided for measurements at the second frequency range. They are used for measuring at least two different electric parameters, which allows to obtain depth-resolved information. The two pairs of electrodes may have one electrode (e.g. the ground electrode) in common.

The third electric parameter is also best measured by means of a dedicated third pair of electrodes, which can be optimized for measurements at the Gigahertz range, e.g. be being designed as coplanar waveguides. Advantageously, at least two pairs of electrodes with different gap widths are provided for measurements at the third frequency range. They are used for measuring at least two different elec-

tric parameters, which again allows to obtain depth-resolved information. The two pairs of electrodes may also have one electrode (e.g. the ground electrode) in common.

The following parameters are found to be particularly indicative for a glucose measurement:

p1 – a value depending on the phases of the impedances measured at several frequencies in the second frequency range at frequencies larger than 30 MHz, measured by means of an electrode having a separation gap of at least 2 mm. Advantageously, if the parameters are subsequently combined using linear or quadratic combinations, the logarithms of the phases of the impedances are used.

p2 – a value depending on the phases of the impedances measured at several frequencies in the second frequency range at frequencies larger than 30 MHz, measured by means of an electrode pair having a separation gap of less than 2 mm. Advantageously, if the parameters are subsequently combined using linear or quadratic combinations, logarithms of the phase of the phases of the impedances are used.

p3 – a value depending on the phases of the impedances measured at several frequencies in the first frequency range at frequencies larger than 100 kHz. Advantageously, if the parameters are subsequently combined using linear or quadratic combinations, logarithms of the phase of the phases of the impedances are used.

p4 – a value depending on the magnitudes of the impedances measured at several frequencies in the first frequency range at frequencies larger than 100 kHz. Advantageously, if the parameters are subsequently combined using linear or quadratic combinations, logarithms of the phase of the phases of the impedances are used.

p5 – a value depending on the phases of the transmission coefficient measured at least one frequency f_1 in the third frequency range, measured by means of an electrode having a separation gap of at least 1 mm. Advantageously, if the parameters are subsequently combined using linear or quadratic combinations, the square of the phase of the transmission is used.

p6 – a value depending on the phases of the transmission coefficient measured at least one frequency f_2 in the third frequency range, measured by means of an electrode having a separation gap of less than 1 mm. Advantageously, if the parameters are subsequently combined using linear or quadratic combinations, the square of the phase of the transmission is used.

p7 – a value depending on the temperature.

In addition to this, the measurement can further be refined by also taking into account at least one of the following parameters

p8 – a value depending on the phases of the impedances measured at several frequencies in the second frequency range between 10 and 30 MHz, measured by means of an electrode having a separation gap of at least 2 mm. Advantageously, if the parameters are subsequently combined using linear or quadratic combinations, the logarithms of the phases of the impedances are used.

p9 – a value depending on the phases of the impedances measured at several frequencies in the second frequency range between 10 and 30 MHz, measured by means of an electrode having a separation gap of less than 2 mm. Advantageously, if the parameters are subsequently combined using linear or quadratic combinations, the logarithms of the phases of the impedances are used.

p10 – a value depending on the magnitude of the impedances measured at several frequencies in the second frequency range at frequencies smaller than 10 MHz, measured by means of an electrode having a separation gap of at least 2 mm. Advantageously, if the parameters are subsequently combined using linear or quadratic combinations, the logarithms of the magnitudes of the impedances are used.

p11 – a value depending on the magnitudes of the impedances measured at several frequencies in the second frequency range at frequencies smaller than 10 MHz, measured by means of an electrode having a separation gap of less than 2 mm. Advantageously, if the parameters are subsequently combined using linear or quadratic combinations, the logarithms of the magnitudes of the impedances are used.

p12 – a value depending on the magnitudes of the transmission coefficient measured at at least one frequency $f1' < f1$ in the third frequency range, measured by means of an electrode having a separation gap of at least 1 mm. Advantageously, if the parameters are subsequently combined using linear or quadratic combinations, the square of the magnitude of the transmission is used.

p13 – a value depending on the magnitudes of the transmission coefficient measured at at least one frequency $f2' < f2$ in the third frequency range, measured by means of an electrode having a separation gap of less than 1 mm. Advantageously, if the parameters are subsequently combined using linear or quadratic combinations, the square of the magnitude of the transmission is used.

Advantageously, when calculating the glucose level, the parameters are weighted with weights, with part of said weights being “global weights”, which are defined as weights that are common for a series of devices, i.e. which do not have

to be adapted to the individual user. Another part of the weights are “user weights”, which are defined as weights that have to be calibrated for individual users. At least the following parameters are advantageously weighted by means of global weights:

p1, p2, p3, p4, p7, and, where applicable, p10, p11

In addition to this, or alternatively, at least the following parameters are advantageously weighed by means of local weights:

p5, p6, and, where applicable, p8, p9, p12, p13.

This is due to the fact that the parameters p5, p6 and, where applicable, p12, p13 mainly account for the changes in water content in the biological tissue, these are proportional to its thickness and may change from case to case. Furthermore, where applicable, the parameters p8 and p9 mainly account for the electrical losses in the biological tissue, which are again proportional to tissue thickness.

For example, the glucose level can be calculated using a linear, weighted sum and an offset, i.e. using a term such as

$$c + \sum_{i=1}^N k_i \cdot p_i,$$

wherein c is an offset, k_i are weights, p_i are the measured parameters and N is the number of measured parameters.

At least some of the weights k_j can be determined in calibration measurements. Advantageously, such calibration measurements comprise a calibration step where the parameters and a series of reference glucose values are measured over an extended period of time. In this context, a “reference glucose value” is a glucose level determined by other means than by means of the present invention, e.g. by analyzing blood samples, by optical measurements, etc.

During the calibration step, terms of the type

$$c_j + \sum_{i=1}^N k_i \cdot p_i$$

are calculated, with c_1, c_2, \dots, c_j being additive values. For a first series of consecutive measurements c_1 is used, for a second series of consecutive measurements c_2 is used, etc. In other words, the series of measurements is divided into sub-series, with each sub-series j having its own additive value c_j . Then, all the additive values c_j and at least part of the parameters k_j are fitted to the reference glucose values. The use of several additive values allows to compensate for a drift in the measurement by minimizing the effect of this latter in the estimation of the parameters k_j .

After this calibration step, the determination of the glucose level in “normal” operation can e.g. comprise the following steps:

measurement of a reference glucose value, i.e. in the morning,

determination of the offset c from the reference glucose value and the weights obtained in the calibration step, and
for subsequent measurements, e.g. during the day, determination of the glucose level from the measured parameters, the weights obtained in the calibration step, and the offset c .

Brief Description of the Drawings

The invention will be better understood and objects other than those set forth above will become apparent when consideration is given to the following detailed description thereof. Such description makes reference to the annexed drawings, wherein:

Fig. 1 shows a sectional view of a device,

Fig. 2 shows a bottom view of the device of Fig. 1,

Fig. 3 is a block circuit diagram of the device,

Fig. 4 is a block circuit diagram of the GHz-electronics of the device,

Fig. 5 shows how glucose content in the biological tissue mainly affect electrical parameters from the second frequency range ($p1$) whilst not affecting the electrical parameters from the other two frequency ranges ($p3$ and $p6$),

Fig. 6 shows how glucose modulates electrical parameters from the second frequency range ($p1$, $p2$) differently at different penetration depths because of different blood vessel concentration along the skin profile,

Fig. 7 shows a change in the state of the biological tissue consequent to a sweat event, occurring at about 10:00, the electrical parameters from the first frequency range ($p3$) measures the change induced at the surface, the electrical parameters from the third frequency range ($p6$) measures the consequent change in the water content in the biological tissue, the electrical parameters from the second frequency range ($p1$) are affected by a combination of these,

Fig. 8 shows a change in the state of the biological tissue consequent to a change in water content, occurring at about 12:10, which is measured by the electrical parameters from the third frequency range ($p5$) and affects the electrical parameters from the second frequency range ($p1$),

Fig. 9 shows that a sweat event, that leads to changes in water content, occurring at about 10:00, modulates electrical parameters from the third fre-

quency range (p5, p6) differently at different penetration depths because water content distribution is not constant along the skin profile,

Fig. 10 shows the dependency of the electrical parameters from the second frequency range (p1) upon temperature (p7).

5

Modes for Carrying Out the Invention

General hardware design

The general design of an advantageous embodiment of the device is shown in Figs. 1 and 2. The device comprises a housing 1, e.g. of plastics. One side of the device, in the following called the “bottom side”, is closed by a substrate 2. Substrate 2 is rectangular and elongate and has a longitudinal axis 3. A band or wrist-band 4 is attached to housing 1, extends perpendicular to longitudinal axis 3 and allows to mount the device e.g. to an arm or leg of a person, with longitudinal axis 3 extending parallel to the longitudinal axis of the arm or leg.

15

At a first side (bottom side) substrate 2 carries an electrode arrangement formed by a structured metal layer 5. Metal layer 5 is shown in gray in Fig. 2. On its second side (top side) electronic components 6 are mounted to substrate 2 and connected to metal leads on the surface or within substrate 2.

20

Housing 1 encloses at least one printed circuit 7 in addition to substrate 2, which carries further electronic components 8. Electrical connectors 9 are provided for connecting printed circuit board 7 to substrate 2.

In addition, the device typically also contains a battery as well as interface and/or display components (not shown).

25

As mentioned, substrate 2 has a first (bottom) side and a second (top) side, with the first side being applied to a person’s skin during operation of the device.

30

Metal layer 5 is structured to form a ground electrode 10 having openings. Signal electrodes 12a, 12b, 13a, 13b, 13c and 14 are placed within these openings, such that gaps 15 are formed between the inner edges of the openings and the outer edges of the signal electrodes. Each signal electrode 12a, 12b, 13a, 13b, 13c and 14 is completely surrounded by such a gap 15.

The electrode arrangement can comprise an optional dielectric layer covering metal layer 5 for mechanically and/or chemically protecting the electrodes.

35

During a measurement, the device is worn with the electrode arrangement applied against the tissue, i.e. the skin of the user.

Electrodes

There are three sets of signal electrodes:

- A first set of signal electrodes 14 are comprised of interdigital electrodes 22 and are operated at the first frequency range between 1 kHz and 200 kHz.

- A second set of signal electrodes 13a, 13b, 13c are operated as capacitive sensors in the second frequency range, i.e. between 0.2 MHz and 100 MHz.

- A third set of signal electrodes 12a, 12b are operated as "coplanar waveguides" (CPW) at frequencies in the third frequency range of at least 1 GHz.

Each signal electrode 12a, 12b, 13a, 13b, 13c, 14 forms an electrode pair together with ground electrode 10.

The primary purpose of the first set of signal electrodes 14 is the measurement of sweat and moisture, as described in section 2.2 of WO 2007/053963. The signal from the signal generator is fed to a contact point in the center of signal electrode 14, and a signal depending on the impedance Z between the signal electrode and the ground electrode is measured, as described in WO 2007/053963.

The width of the fingers of the interdigital electrodes as well their mutual distance is advantageously in the order of 0.15 mm.

The electrodes 13a, 13b, 13c of the second set are strip-shaped. The signal from the signal generator is fed to a contact point in the center of the signal electrode, and a signal depending on the impedance Z between the signal electrode and the ground electrode is measured, as e.g. described in WO 2007/053963 or WO 2005/053523.

Differing electrode geometries are used in order to generate electric fields reaching into different depths of the tissue. Hence, the widths of the gaps around the signal electrodes 13a, 13b, 13c differ. Advantageously: for signal electrode 13a, the width of the gap as well as the width of the signal electrode are typically 4 mm, for signal electrode 13b the width of the gap as well as the width of the signal electrode are typically 1.5 mm, and for signal electrode 13c the width of the gap as well as the width of the signal electrode are typically 0.3 mm. The length of the signal electrodes 13a, 13b, 13c should be as large as possible in order to have a large measured volume of skin and underlying tissue.

The signal electrodes 13a, 13b, 13c extend parallel to each other and parallel to the longitudinal axis 3, which increases the interaction length between the electrodes and the tissue within the wearer's arm or leg.

Each signal electrodes 12a, 12b of the third set forms a conductor-backed coplanar waveguide together with the surrounding part of ground electrode 10

and a shield electrode embedded within or arranged on the opposite side of substrate 2. The signal from the signal generator is fed to a first end of the signal electrode and the signal at the second, opposite end is fed to a signal detector, which will be described below.

5 Again, as described in WO 2005/120332 and WO 2007/053963, it is advantageous to generate electric fields reaching into different depths of the tissue, for which purpose the width of the gaps around the signal electrodes 12a and 12b differ. Advantageously: for signal electrode 12a, the width of the gap is typically up to 4 mm, for signal electrode 12b the width of the gap is typically up to 0.15 mm. Both
10 signal electrodes 12a, 12b have a width of 0.2 mm or less and a length of 20 – 23 mm.

The signal electrodes 12a, 12b of the third set are parallel to each other and extend perpendicularly to longitudinal axis 3. It has been found that for high-frequency sensors of this type, an arrangement perpendicular to the arm/leg of
15 the wearer provides more robust measurements that are less prone to signal errors due to mechanical shifts related to sensor contact with the skin. However, the signal electrodes 12a, 12b may also extend parallel to longitudinal axis 3.

Optical Sensors

20 As described in WO 2007/053963, it is advantageous to combine the electrical measurements with optical measurements, in particular optical reflectance measurements. For this purpose, the device can be equipped with at least one optical reflection sensor. Such a sensor allows to obtain a measure of the perfusion of the tissue.

25 In the embodiment of Fig. 2, the device comprises two such optical reflection sensors 23a and 23b. Each optical reflection sensor 23a, 23b is arranged in the gap around signal electrode 13a.

Each optical reflection sensor 23a, 23b advantageously comprises at least one light source and at least one light detector. In the embodiment shown in Fig.
30 2, each optical reflection sensor comprises three light sources 27a, 27b, 27c arranged in a row that extends perpendicularly to the longitudinal axis of the sensor. The light sources 27a, 27b, 27c advantageously emit light in the visible or near-infrared spectral range. Furthermore, in the embodiment of Fig. 2, each optical reflection sensor comprises two light detectors 28a, 28b, with the light sources 27a, 27b, 27c located
35 between the light detectors 28a, 28b, such that the light detectors 28a, 28b are able to sense light scattered in forward as well as backward direction respectively to the lon-

itudinal axis of the sensor but having different separations to the light sources 27a, 27b and 27c allowing for perfusion at different depths in the tissue to be measured.

Using at least two light sources with different optical emission spectra has the advantage that differing tissue processes giving rise to a spectrally differing reflectance changes can be distinguished.

In particular, if two light sources are used, one should generate a wavelength below 600 nm and the other a wavelength above 700 nm, advantageously at approximately 568 nm and 800 nm. If three light sources are used, the first one should advantageously generate light at a wavelength below 600nm, the second one light of a wavelength above 700 nm, and the third one light at a wavelength between 600 and 700 nm. Advantageous values were found to be 568 nm, 800 nm and 660 nm, respectively. It must be noted that 568 nm and 800 nm are "isosbestic" points where the haemoglobin absorption does not depend on the level of oxygenation. In order to correct for skin perfusion changes, the haemoglobin related signal can be calculated by the ratio of the absorption at 568 nm and 800 nm. The oxygen signal can be calculated at 660 nm, a wavelength where the difference between the absorbance of oxygenated and deoxygenated haemoglobin is at its largest, as a ratio to the 800nm.

Electronics:

Fig. 3 shows a block diagram of an embodiment of the device. It comprises a control unit 30, e.g. a microprocessor with program and data memory as known to the skilled person, which controls the operation of the device. It is connected to various sensors, in particular:

a) A low-frequency sensor 31 operated by a signal generator and signal detector in the first frequency range, which uses the interdigital electrodes 22 for its measurements.

b) A medium-frequency sensor 32 operated by a signal generator and signal detector in the second frequency range, which uses the second set of signal electrodes 13a, 13b, 13c for its measurements.

c) A high-frequency sensor 33 operated by a signal generator and signal detector in the third frequency range, which uses the third set of signal electrodes 12a, 12b for its measurements.

d) An optical detector 34 measuring optical reflection by means of the optical reflection sensors 23a, 23b, 23c.

e) A temperature sensor 35 measuring a temperature of the surface of the tissue as well as, optionally, the temperature within housing 1, e.g. by means of

a first temperature sensing device in direct thermal contact with substrate 2, as well as by means of a second temperature sensing device arranged inside housing 1.

Note: In the present embodiment, the signal generators of the low-frequency sensor 31, medium-frequency sensor 32 and high-frequency sensor 33 form the “signal generation circuit” as referred to in the claims.

In addition to the sensors, control unit 30 controls an interface 3 for exchanging data with an external device, which is used for analyzing and displaying the data measured by the present device. It must be noted, though, that this type of functionality can also be incorporated into the present device itself.

Fig. 4 shows a more detailed diagram of the high-frequency sensor 33. It comprises a voltage-controlled oscillator 40 with two identical outputs. One of the outputs is connected to a first switch 41, from where it is selectively sent to the input end Tx1, Tx2 of one of the signal electrodes 12a, 12b. The appropriate one of the signals Rx1, Rx2 from the output ends of the signal electrodes 12a, 12b is selected with a second switch 42 and fed to a first input of a magnitude/phase detector 43. The other output of oscillator 40 is routed through two static switches 44, 45 of the same type as the switches 41, 42 and then to the second input of magnitude/phase detector 43. The purpose of the static switches 44, 45 is to increase the symmetry of the two signal paths from oscillator 40 to magnitude/phase detector 43 in terms of temperature and technological variations.

Magnitude/phase detector 43 measures the relative magnitude and phase of the signals at its two inputs, which correspond to the complex transmission T of the coplanar waveguide, and feeds the corresponding value to an A/D converter 46.

Glucose determination

Control unit 30 is structured and adapted by means of software and the above hardware to determine the glucose level g from the measured parameters.

The basic principles of operation of this type of device are described in WO 2007/053963. In most general terms, glucose level g can be determined from the measured parameters p_i with $i = 1, 2, \dots, N$ using a suitable function f as

$$g = f(p_1, \dots, p_N).$$

In many cases, and in particular when suitably choosing the parameters p_i , function f can be a linear or polynomial function in the parameters p_i . In

a most simple approach, the glucose level can be determined from the measurements of the device described above by means of the following linear combination

$$c + k_1 \cdot p_1 + k_2 \cdot p_2 + k_3 \cdot p_3 + k_4 \cdot p_4 + k_5 \cdot p_5 + k_6 \cdot p_6 + k_7 \cdot p_7,$$

5

where c is an offset constant, to be determined via a reference measurement of glucose performed in the morning and kept constant during the day. The weights coefficient k_i are determined via calibration to reference measurements as described below, and the measured parameters p_i are as follows.

10

p1 – the average or a weighted sum of the logarithms of the phase of the impedance as measured by the electrode 13a (“large”) of Fig.1 at the frequencies: 35, 40, and 45 MHz, namely

$$p_1 = \frac{1}{3} \sum_{i=1}^3 \log_{10} \left(\angle \left(Z_{el2} (f_i) \right) \right),$$

$$f_i = \{35, 40, 45\} \text{ MHz}$$

15

where $\angle(Z)$ denotes the phase of the complex variable Z ,

p2 – the average of the logarithms of the phase of the impedance as measured by the electrode el3 (“middle”) of Fig.1 at the frequencies: 35, 40, and 45 MHz, namely

$$p_2 = \frac{1}{3} \sum_{i=1}^3 \log_{10} \left(\angle \left(Z_{el3} (f_i) \right) \right),$$

$$f_i = \{35, 40, 45\} \text{ MHz}$$

20

p3 – the average of the logarithms of the phase of the impedance as measured by electrode 14 of Fig.1 at the frequencies: 100, 150, and 200 kHz, namely

$$p_3 = \frac{1}{3} \sum_{i=1}^3 \log_{10} \left(\angle \left(Z_{el1} (f_i) \right) \right),$$

$$f_i = \{100, 150, 200\} \text{ kHz}$$

25

p4 – the average of the logarithms of the magnitude of the impedance as measured by electrode 14 of Fig.1 at the frequencies: 100, 150, and 200 kHz, namely

$$p_4 = \frac{1}{3} \sum_{i=1}^3 \log_{10} \left(|Z_{el1}(f_i)| \right),$$

$$f_i = \{100, 150, 200\} \text{ kHz}$$

p5 – the square of the phase of the transmission coefficient as measured by the electrode 12a of Fig.1 at the 2.02GHz, namely

$$p_5 = \left(\angle \left(T_{el4}(2.02\text{GHz}) \right) \right)^2,$$

with f1 as defined above being 2.02 GHz;

p6 – the square of the phase of the transmission coefficient as measured by the electrode 12b of Fig.1 at the 2.02GHz, namely

$$p_6 = \left(\angle \left(T_{el5}(2.02\text{GHz}) \right) \right)^2,$$

with f2 as defined above being 2.02 GHz;

p7 – the temperature measured in close proximity of the tissue by temperature sensor 35.

The first two terms are directly proportional to the changes in the beta dispersion induced by the changes in glucose concentration in the tissue (cf. Fig. 5). The two separation gaps allow addressing different penetration depths, where the beta dispersion is differently modulated because of different blood vessel concentration along the skin profile (cf. Fig. 6).

The third and fourth terms are necessary for accounting and compensating changes in impedance due to sweat events but unrelated to changes in glucose (cf. Fig. 7 for p_3 , similar dependencies are observed for p_4).

The fifth and sixth terms are necessary for accounting and compensating changes in impedance due to changes in the water content of the skin but unrelated to changes in glucose (cf. Fig. 8 for p_5 , similar dependencies are observed for p_6). Again, the two separation gaps allow addressing the water content distribution which is not constant along the skin profile (cf. Fig. 9).

The seventh term is necessary for accounting and compensating changes in impedance due to changes in temperature of the skin but unrelated to changes in glucose (cf. Fig. 10).

Advantageously, the glucose estimation can be further refined by considering also the following terms, namely by expanding the combination as follows

$$c + k_1 \cdot p_1 + k_2 \cdot p_2 + k_3 \cdot p_3 + k_4 \cdot p_4 + k_5 \cdot p_5 + k_6 \cdot p_6 + k_7 \cdot p_7 + k_8 \cdot p_8 + k_9 \cdot p_9 + k_{10} \cdot p_{10} + k_{11} \cdot p_{11} + k_{12} \cdot p_{12} + k_{13} \cdot p_{13}$$

where the first eight terms (from c to $k_7 \cdot p_7$) are the same as described above. The weights coefficient k_i ($i=8\dots 13$) are similarly determined via calibration to reference measurements as described below, and the measured parameters p_i ($i=8\dots 13$) are as followings.

p8 – the average of the logarithms of the phase of the impedance as measured by electrode 13a of Fig.1 at the frequencies: 15, 20, and 25 MHz, namely

$$p_8 = \frac{1}{3} \sum_{i=1}^3 \log_{10} \left(\angle \left(Z_{el2} (f_i) \right) \right),$$

$$f_i = \{15, 20, 25\} \text{ MHz}$$

p9 – the average of the logarithms of the phase of the impedance as measured by the electrode el3 (“middle”) of Fig.1 at the frequencies: 15, 20, and 25 MHz, namely

$$p_9 = \frac{1}{3} \sum_{i=1}^3 \log_{10} \left(\angle \left(Z_{el3} (f_i) \right) \right),$$

$$f_i = \{15, 20, 25\} \text{ MHz}$$

p10 – the average of the logarithms of the magnitude of the impedance as measured by the electrode 13a of Fig.1 at the frequencies: 0.5, 1, 2, and 5 MHz, namely

$$p_{10} = \frac{1}{4} \sum_{i=1}^4 \log_{10} \left(\left| Z_{el2} (f_i) \right| \right),$$

$$f_i = \{0.5, 1, 2, 5\} \text{ MHz}$$

p11 – the average of the logarithms of the magnitude of the impedance as measured by the electrode el3 (“middle”) of Fig.1 at the frequencies: 0.5, 1, 2, and 5 MHz, namely

$$p_{11} = \frac{1}{4} \sum_{i=1}^4 \log_{10} \left(\left| Z_{el3} (f_i) \right| \right),$$

$$f_i = \{0.5, 1, 2, 5\} \text{ MHz}$$

p12 – the magnitude of the transmission coefficient as measured by electrode 12a of Fig.1 at the 1.10 GHz, namely

$$p_{12} = |T_{e/4}(1.10\text{GHz})|,$$

with f_1' as defined above being 1.10 GHz;

p13 – the magnitude of the transmission coefficient as measured by
5 electrode 12b of Fig.1 at the 1.10 GHz, namely

$$p_{13} = |T_{e/4}(1.10\text{GHz})|,$$

with f_2' as defined above being 1.10 GHz;

10 p8 and p9 allow better characterizing the modulation of the beta dispersion due to glucose concentration changes, whilst all other terms allow accounting and compensating for changes in the electrical dispersive properties of the tissue which are unrelated to glucose changes.

15 *Experimental results*

The above comments on the properties of the various parameters refer to enclosed Figs. 5 – 10. These figures show the measured values of the respective parameters as well as of a invasively measured glucose level as a function of time.

20 Study procedure Fig. 5 / Fig. 6 / Fig. 8 / Fig. 10:

The patients arrived in the clinical study unit in the morning. An intravenous (i.v.) insulin infusion was established and the Multisensor attached to the upper arm by an expandable band (proximal/distal location). After a run-in period of
25 75 minutes during which the glucose level was stabilized at an euglycaemic level, glucose was administered orally to induce one hyperglycaemic excursion. Euglycaemia was re-established by an i.v. insulin infusion.

In order to assure close blood glucose (BG) monitoring, changes in the BG were measured with a reference standard technique (HemoCue Glucose Analyzer) from intravenous blood samples.
30

Study procedure Fig. 7 / Fig. 9:

The patients have worn the Multisensor on the upper arm during the day time at home or work. No glucose excursions were induced, but normal daily
35 glucose variations were present.

The patients have performed frequent self monitoring of blood glucose (SMBG) of at least 10 finger pricks per day with a standard blood glucose meter (BGM).

Events Fig. 5 / Fig. 6:

The patient was lying in bed in hospital.

13:00h: The Multisensor was detached and reattached to the skin.

5

Events Fig. 7 / Fig. 9:

The patient is at home and possibly active.

10:00h: The patient is sweating. The sweat on the skin surface and moisture balance in the skin are both affected. No physical exercise during that time.

10

Events Fig. 8 / Fig. 10

The patient was lying in bed in hospital.

12:10h: The patient is changing his position. The water/tissue balance in the skin is affected.

15

14:30h: The room temperature and therefore also the skin temperature drops.

Calibration

Here follows a description of the calibration using “run3” (which is now called c_j in the claims.

The calibration of the coefficients k_i ($i=1\dots7$ or $i=1\dots13$) can be performed as following.

Measurement data (p1 to p7 or p1 to p13) and the corresponding reference glucose values are collected across several days at a regular interval of one measurement every hour. The data are first divided into sub-series of 4 hours each, then, terms of the type

25

$$c_j + \sum_{i=1}^N k_i \cdot p_i$$

are fitted, with respect to the coefficient k_i , in least square sense to the reference glucose values, where a different additive constant c_j is allowed for each sub-series. The use of several additive values allows compensating for a drift in the measurement by minimizing the effect of this latter in the estimation of the parameters k_j .

30

Afterwards, the determination of the glucose level in “normal” operation is performed as following.

35

First, a measurement of a reference glucose value is collected in the morning concurrently with a measurement set from the device, i.e. values of the pa-

rameters p1 to p7 or p1 to p13. With these measurements the offset c is determined by subtracting from the reference glucose value the weighted sum of the parameters weighted with the weights obtained in the calibration step described above.

After computation of the offset, for subsequent measurements during the rest of the day, the glucose level is computed from the measured parameters, the weights obtained in the calibration step, and the offset c .

Notes

The above description as well as the claims mention that a voltage is generated by the signal generation circuit. This formulation is not meant to restrict the signal generation circuit to a voltage source controlled to provide a given voltage, but it may also be a current source controlled to provide a given current, or it may be any other circuit generating a voltage giving rise to a current in the tissue.

As mentioned above, the device can also be equipped with optical sensors. The signals, or the logarithms of the signals, measured by these sensors can also be incorporated as further parameters p14, p15 in the linear combination of parameters for determining the glucose level.

Various of the parameters described above are determined from an average of measurements at different frequencies. Alternatively, a weighted sum can be used for the same purpose, wherein the weights can e.g. be obtained in a fitting process varying the weights in order to fit the calculated glucose level to a sufficiently large number of experimentally measured reference glucose levels.

Alternatively to the magnitude and phase parameterization of the electrical properties, the real and imaginary parts can be considered instead.

Advantageously, fitting criteria alternative to the least square can be considered, e.g. least absolute deviation, max absolute deviation, robust least squares, and regularized least squares.

While there are shown and described presently preferred embodiments of the invention, it is to be distinctly understood that the invention is not limited thereto but may be otherwise variously embodied and practiced within the scope of the following claims.

Claims

1. A device for measuring a glucose level in living tissue, said device comprising

5 an electrode arrangement to be applied against said tissue,
a signal generation circuit, wherein said signal generation circuit is connected to said electrode arrangement in order to generate an AC signal voltage in said electrode arrangement,

10 a measuring circuit for measuring a response of said tissue to a field generated by said electrodes due to said signal voltage,

a first temperature sensor generating a first temperature signal indicative of a temperature of said tissue,

15 a control unit for operating said signal generation circuit, wherein said control unit is structured and adapted to operate said signal generation circuit and said measuring circuit at least at a first frequency for measuring a first electric parameter, at a second frequency for measuring a second electric parameter and at a third frequency for measuring a third electric parameter, wherein said first frequency is in a first frequency range between 1 kHz and 200 kHz, said second frequency is in a second frequency range between 0.2 MHz and 100 MHz, and said third frequency is
20 in a third frequency range above 1 GHz,

wherein said control unit is further structured and adapted to derive said glucose level from a combination of at least said first, second and third electric parameter and said first temperature parameter.

25 2. The device of claim 1 wherein said third frequency range is between 1 GHz and 30 GHz.

30 3. The device of any of the preceding claims wherein said control unit is structured and adapted to operate said signal generation circuit and said measuring circuit to measure several electric parameters at different frequencies in said first frequency range and/or to measure several electric parameters at different frequencies in said second frequency range and/or to measure several electric parameters at different frequencies in said third frequency range.

35 4. The device of any of the preceding claims wherein said electrode arrangement comprises a pair of first, interdigital electrodes and wherein said control unit is structured and adapted to measure said first electric parameter by means of said first electrodes.

5. The device of any of the preceding claims wherein said electrode arrangement comprises a second pair of electrodes separated by a gap of at least 2

mm and wherein said control unit is structured and adapted to measure said second electric parameter by means of said second electrodes.

6. The device of claim 5 wherein said electrode arrangement comprises at least two pairs of electrodes for measurements at said second frequency range, wherein said two pairs of electrodes have different gap widths, and wherein said control unit is structured and adapted to measure at least two electric parameters with said two electrodes at said second frequency range.

7. The device of any of the preceding claims wherein said electrode arrangement comprises a third pair of electrodes and wherein said control unit is structured and adapted to measure said third electric parameter by means of said third electrodes, and in particular wherein said third pair of electrodes forms a coplanar waveguide.

8. The device of claim 7 wherein said electrode arrangement comprises at least two pairs of electrodes for measurements at said third frequency range, wherein said two pairs of electrodes have different gap widths, and wherein said control unit is structured and adapted to measure at least two electric parameters with said two electrodes at said third frequency range.

9. The device of any of the preceding claims wherein said control unit further comprises a second temperature sensor for measuring a second temperature electric parameter indicative of a temperature within said device.

10. The device of any of the preceding claims wherein said control unit is structured and adapted to determine said glucose level from following parameters p1 – p7:

p1 – a value depending on the phases of the impedances measured at several frequencies in the second frequency range at frequencies larger than 30 MHz, measured by means of an electrode having a separation gap of at least 2 mm,

p2 – a value depending on the phases of the impedances measured at several frequencies in the second frequency range at frequencies larger than 30 MHz, measured by means of an electrode pair having a separation gap of less than 2 mm,

p3 – a value depending on the phases of the impedances measured at several frequencies in the second frequency range at frequencies larger than 100 kHz,

p4 – a value depending on the magnitudes of the impedances measured at several frequencies in the second frequency range at frequencies larger than 100 kHz,

p5 – a value depending on the phases of the transmission coefficient measured at at least one frequency in the third frequency range, measured by means of an electrode having a separation gap of at least 1 mm,

p6 – a value depending on the phases of the transmission coefficient measured at at least one frequency in the third frequency range, measured by means of an electrode having a separation gap of less than 1 mm, and

p7 – a value depending on the temperature.

11. The device of claim 10 wherein said control unit is structured and adapted to calculate logarithms of the parameters p1, p2, p3, p4 and/or to calculate squares of the parameters p5 and p6.

12. The device of any of the claims 10 or 11 wherein said control unit is structured and adapted to determine said glucose level further from at least one of following parameters p8 – p13

p8 – a value depending on the phases of the impedances measured at several frequencies in the second frequency range between 10 and 30 MHz, measured by means of an electrode having a separation gap of at least 2 mm,

p9 – a value depending on the phases of the impedances measured at several frequencies in the second frequency range between 10 and 30 MHz, measured by means of an electrode having a separation gap of less than 2 mm,

p10 – a value depending on the magnitude of the impedances measured at several frequencies in the second frequency range at frequencies smaller than 10 MHz, measured by means of an electrode having a separation gap of at least 2 mm,

p11 – a value depending on the magnitudes of the impedances measured at several magnitudes in the second frequency range at frequencies smaller than 10 MHz, measured by means of an electrode having a separation gap of less than 2 mm,

p12 – a value depending on the magnitudes of the transmission coefficient measured at at least one frequency $f1' < f1$ in the third frequency range, measured by means of an electrode having a separation gap of at least 1 mm, and/or

p13 – a value depending on the magnitudes of the transmission coefficient measured at at least one frequency $f2' < f2$ in the third frequency range, measured by means of an electrode having a separation gap of less than 1 mm.

13. A method for determining a glucose level in living tissue, said method comprising the steps of

applying an electrode arrangement to said tissue,

applying an AC signal voltage to said electrode arrangement, said

5 AC signal voltage comprising a first frequency between 1 kHz and 200 kHz, a second frequency between 0.2 MHz and 100 MHz, and a third frequency of at least 1 GHz,

measuring a first, second and third electric parameters indicative of a response of said tissue to said AC signal voltage at said first, second and third frequencies,

10 measuring a first temperature parameter indicative of a temperature of said tissue, and

combining said first, second and third electric parameter and said temperature signal for deriving said glucose level.

14. The method of claim wherein said glucose level is determined from following parameters p1 – p7:

15 p1 – a value depending on the phases of the impedances measured at several frequencies in the second frequency range at frequencies larger than 30 MHz, measured by means of an electrode having a separation gap of at least 2 mm,

20 p2 – a value depending on the phases of the impedances measured at several frequencies in the second frequency range at frequencies larger than 30 MHz, measured by means of an electrode pair having a separation gap of less than 2 mm,

25 p3 – a value depending on the phases of the impedances measured at several frequencies in the second frequency range at frequencies larger than 100 kHz,

p4 – a value depending on the magnitudes of the impedances measured at several frequencies in the second frequency range at frequencies larger than 100 kHz,

30 p5 – a value depending on the phases of the transmission coefficient measured at at least one frequency in the third frequency range, measured by means of an electrode having a separation gap of at least 1 mm,

p6 – a value depending on the phases of the transmission coefficient measured at at least one frequency in the third frequency range, measured by means of an electrode having a separation gap of less than 1 mm, and

35 p7 – a value depending on the temperature,

and in particular wherein at least one of the following parameters is used in addition to said parameters p1 – p7:

p8 – a value depending on the phases of the impedances measured at several frequencies in the second frequency range between 10 and 30 MHz, measured by means of an electrode having a separation gap of at least 2 mm,

p9 – a value depending on the phases of the impedances measured at several frequencies in the second frequency range between 10 and 30 MHz, measured by means of an electrode having a separation gap of less than 2 mm,

p10 – a value depending on the magnitude of the impedances measured at several frequencies in the second frequency range at frequencies smaller than 10 MHz, measured by means of an electrode having a separation gap of at least 2 mm,

p11 – a value depending on the magnitudes of the impedances measured at several magnitudes in the second frequency range at frequencies smaller than 10 MHz, measured by means of an electrode having a separation gap of less than 2 mm,

p12 – a value depending on the magnitudes of the transmission coefficient measured at at least one frequency $f1' < f1$ in the third frequency range, measured by means of an electrode having a separation gap of at least 1 mm, and/or

p13 – a value depending on the magnitudes of the transmission coefficient measured at at least one frequency $f2' < f2$ in the third frequency range, measured by means of an electrode having a separation gap of less than 1 mm.

15. The method of claim 14 comprising the step of determining said glucose level by weighting said parameters with weights, wherein part of said weights are global weights that are common for a series of devices, while part of said weights are user weights that are calibrated for individual users, wherein at least the following parameters are weighed by means of global weights

p1, p2, p3, p4, p7, and, where applicable, p10, p11 and/or at least the following parameters are weighed by means of user weights

p5, p6, and, where applicable, p8, p9, p12, p13

16. The method of any of the claims X or X+1, wherein said glucose is calculated using the term

$$c + \sum_{i=1}^N k_i \cdot p_i ,$$

wherein c is an offset, k_i are weights, p_i are the measured parameters and N is the number of measured parameters.

17. The method of claim 16 further comprising a calibration step, said calibration step including

measuring said parameters and a series of reference glucose values
over an extended period of time,

calculating

$$c_j + \sum_{i=1}^N k_i \cdot p_i ,$$

5 with c_1, c_2, \dots, c_J being additive values, wherein for a first series of consecutive measurements c_1 is used, for a second series of consecutive measurements c_2 is used, etc.,

fitting all said additive values c_j and at least part of said parameters
to said reference glucose values,

10 wherein, after said calibration step, that glucose is determined by
measuring a reference glucose value,

determining said offset c from said reference glucose value and the
weights obtained in said calibration step, and, subsequently,

15 determining said glucose level from said measured parameters, said
weights obtain in said calibration step, and said offset c .

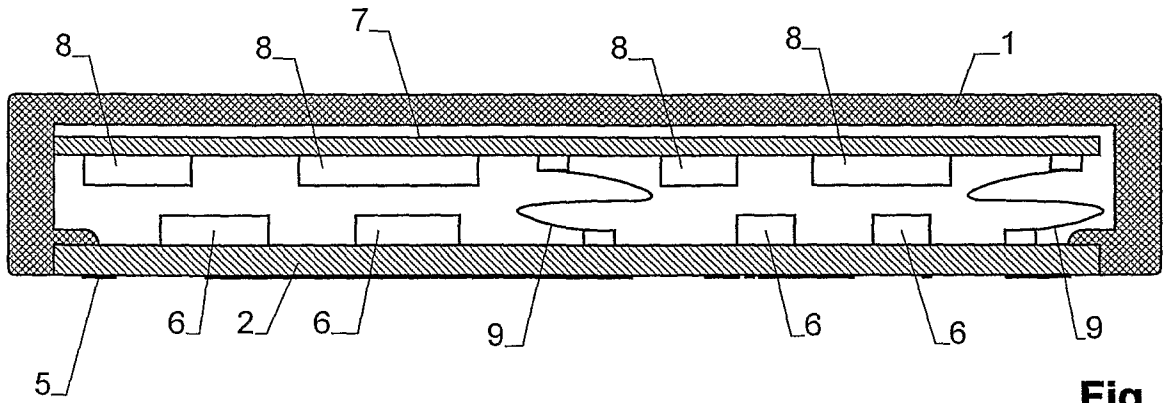

Fig. 1

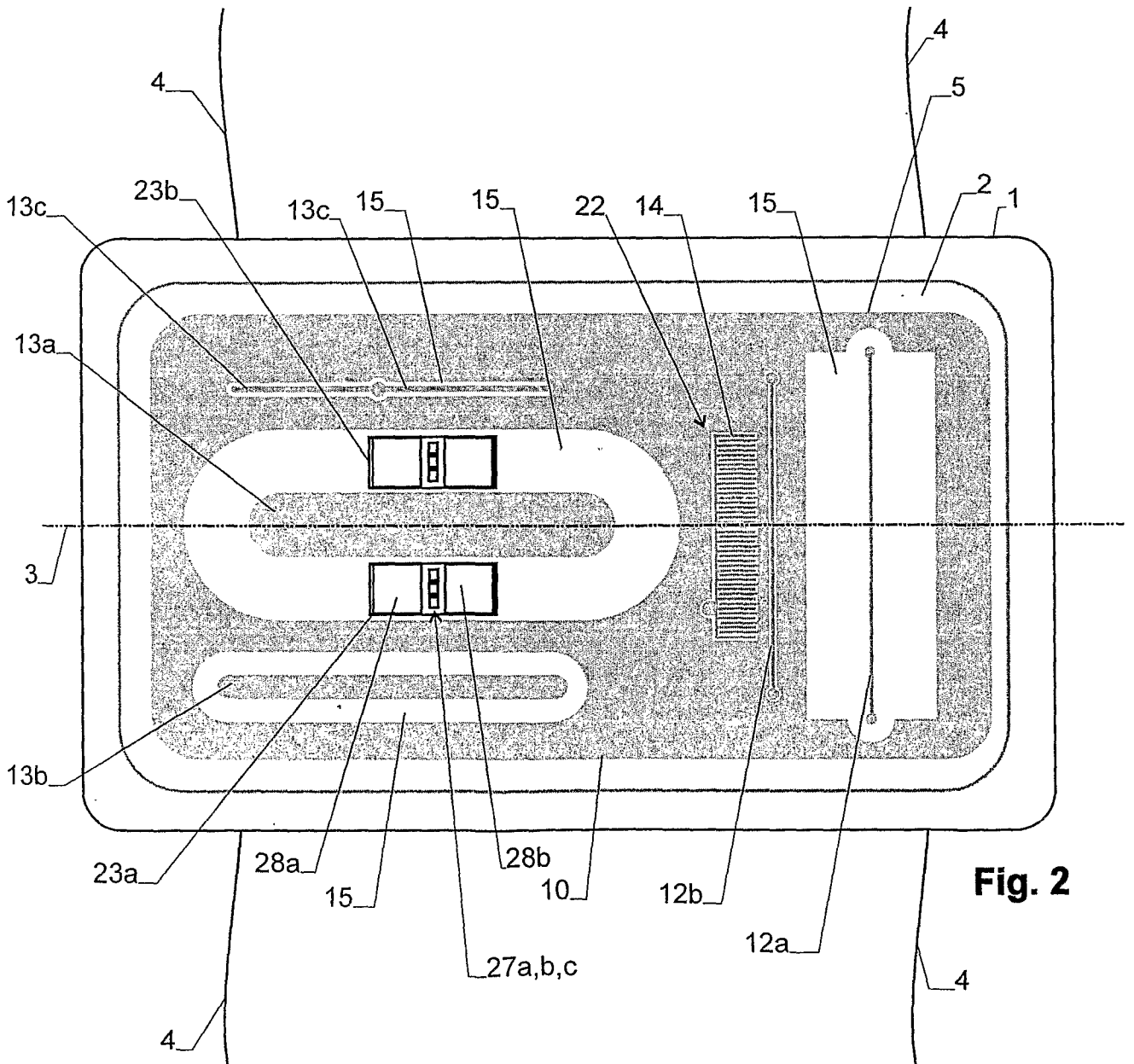

Fig. 2

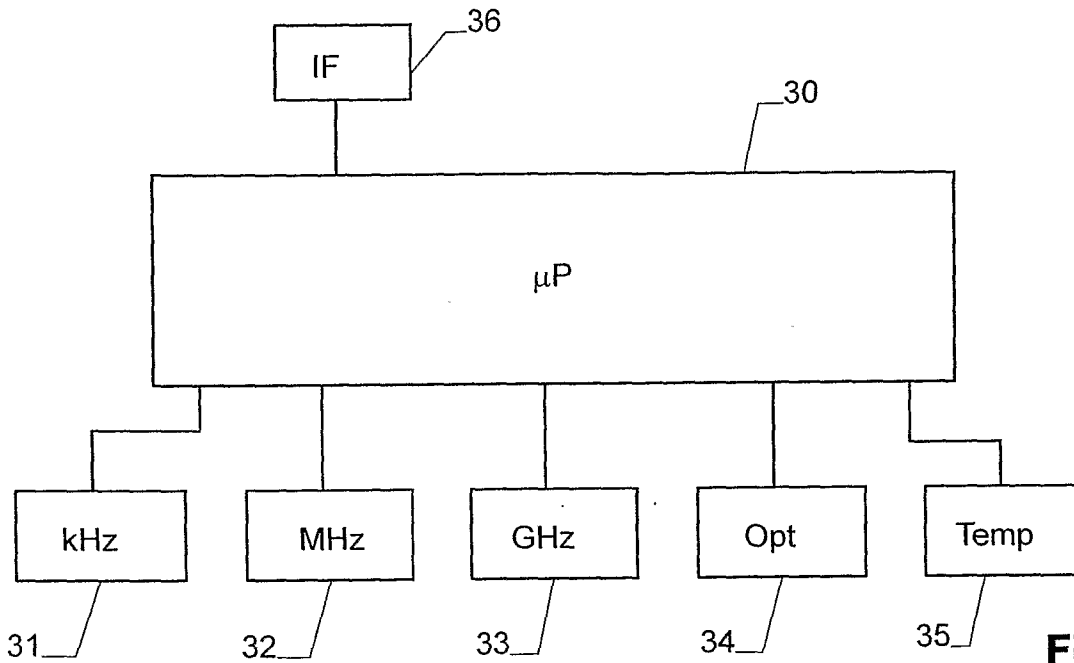

Fig. 3

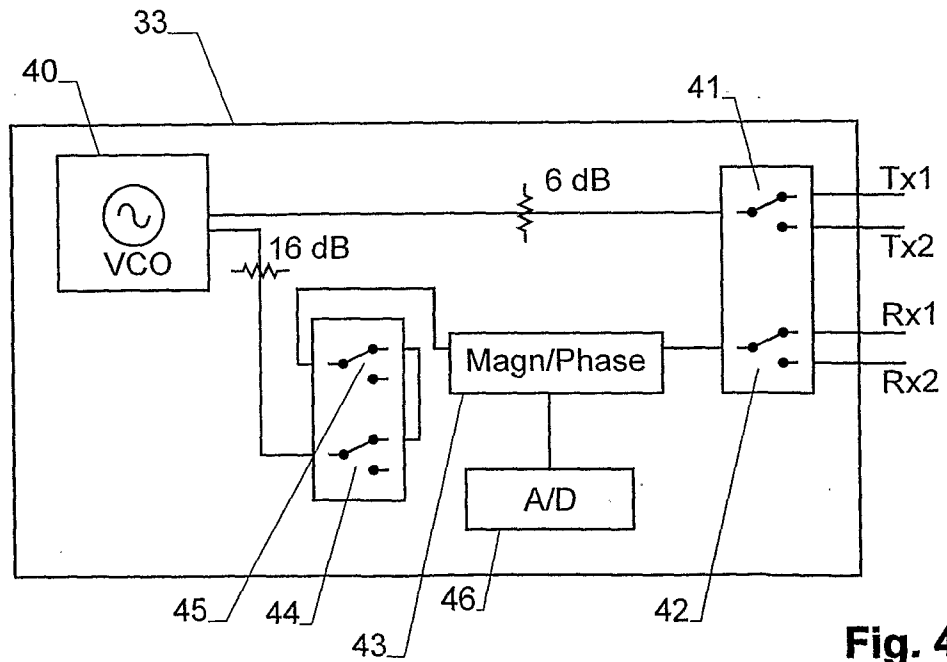

Fig. 4

3/4

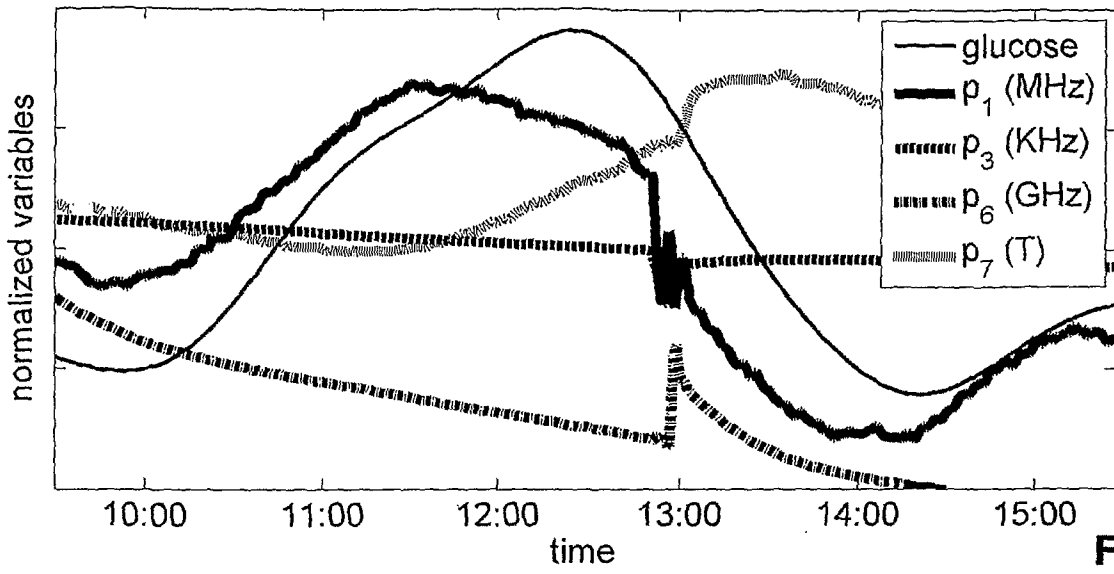

Fig. 5

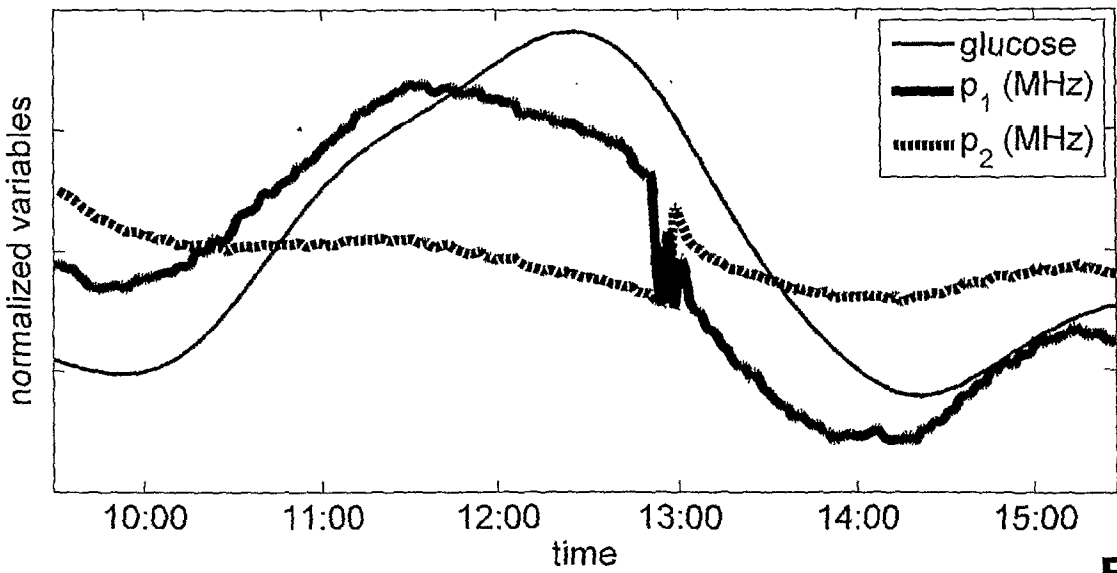

Fig. 6

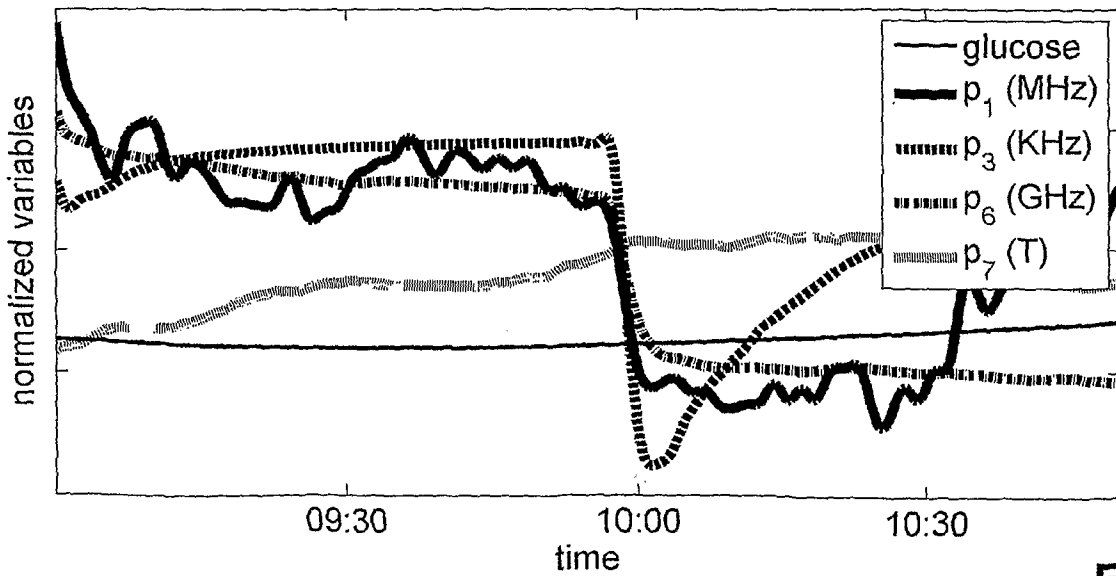

Fig. 7

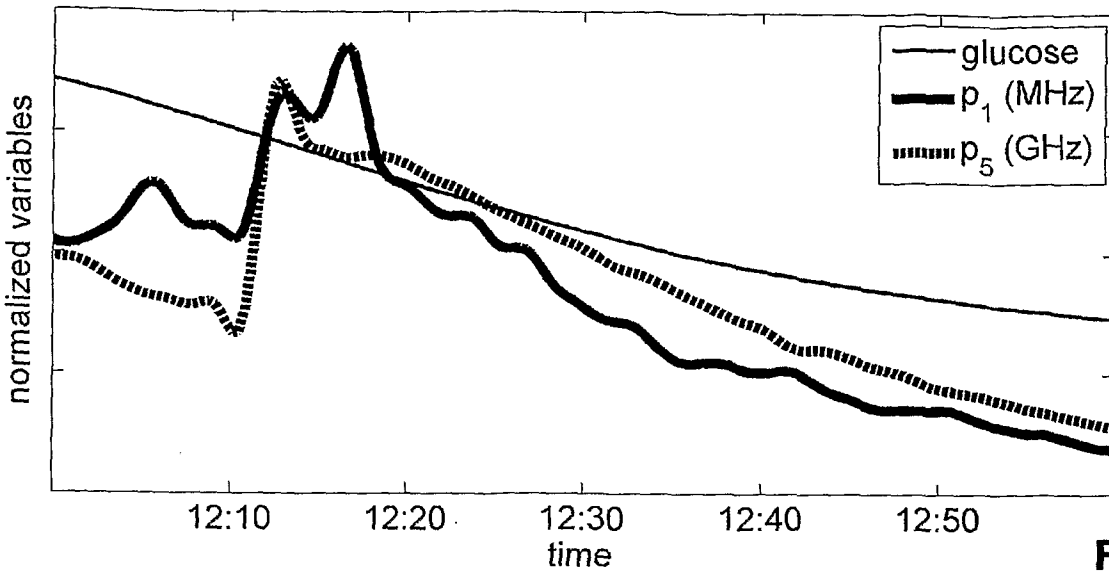

Fig. 8

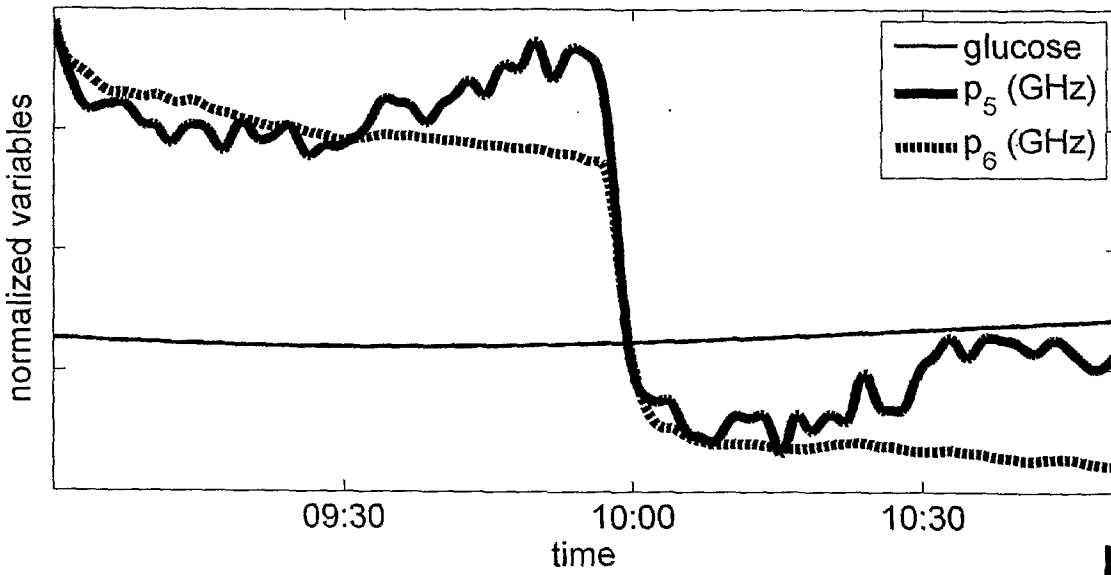

Fig. 9

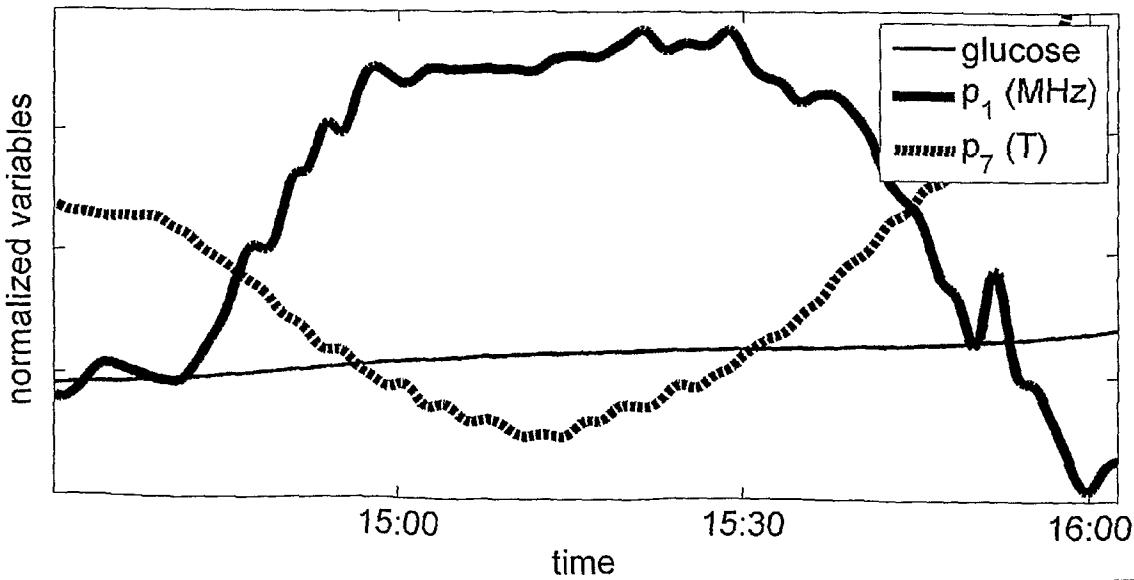

Fig. 10

INTERNATIONAL SEARCH REPORT

International application No

PCT/CH2009/000122

C(Continuation). DOCUMENTS CONSIDERED TO BE RELEVANT

Category*	Citation of document, with indication, where appropriate, of the relevant passages	Relevant to claim No.
Y	CADUFF A ET AL: "Non-invasive glucose monitoring in patients with Type 1 diabetes: A Multisensor system combining sensors for dielectric and optical characterisation of skin" BIOSENSORS AND BIOELECTRONICS, ELSEVIER BV, NL, vol. 24, no. 9, 20 February 2009 (2009-02-20), pages 2778-2784, XP026053065 ISSN: 0956-5663 DOI: 10.106/j.bios.2009.02.001 [retrieved on 2009-02-20]	4-6
A	page 2780, left-hand column, lines 14-17 page 2780, right-hand column, lines 7-12 page 2780, right-hand column, lines 33-36 figures 1-3	1-3,7-17
X	----- WO 2005/077260 A1 (BIOPEAK CORP [CA]; BRYENTON ALAN [CA]; BATKIN IZMAIL [CA]) 25 August 2005 (2005-08-25)	1-3,13
A	paragraphs [0001], [0006], [0008], [0019], [0022], [0025], [0050], [0063], [0067], [0068], [0070], [0077] figures 1,4-6,15,17,18	10,14
A	----- WO 2005/053523 A1 (PENDRAGON MEDICAL LTD [CH]; CADUFF ANDREAS [CH]; BUSCHOR STEPHAN [CH];) 16 June 2005 (2005-06-16) cited in the application the whole document	1-17
A	----- WO 00/09996 A1 (SOLID STATE FARMS INC [US]) 24 February 2000 (2000-02-24) the whole document	1-17
A	----- GB 2 428 801 A (HANCOCK CHRISTOPHER PAUL [GB]; MICROONCOLOGY LTD [GB]) 7 February 2007 (2007-02-07) page 1, lines 46-48 the whole document	1-17

INTERNATIONAL SEARCH REPORT

International application No.
PCT/CH2009/000122

Box No. II Observations where certain claims were found unsearchable (Continuation of item 2 of first sheet)

This international search report has not been established in respect of certain claims under Article 17(2)(a) for the following reasons:

1. Claims Nos.: 13-17(partially)
because they relate to subject matter not required to be searched by this Authority, namely:
see FURTHER INFORMATION sheet PCT/ISA/210
2. Claims Nos.:
because they relate to parts of the international application that do not comply with the prescribed requirements to such an extent that no meaningful international search can be carried out, specifically:
3. Claims Nos.:
because they are dependent claims and are not drafted in accordance with the second and third sentences of Rule 6.4(a).

Box No. III Observations where unity of invention is lacking (Continuation of item 3 of first sheet)

This International Searching Authority found multiple inventions in this international application, as follows:

see additional sheet

1. As all required additional search fees were timely paid by the applicant, this international search report covers all searchable claims.
2. As all searchable claims could be searched without effort justifying an additional fees, this Authority did not invite payment of additional fees.
3. As only some of the required additional search fees were timely paid by the applicant, this international search report covers only those claims for which fees were paid, specifically claims Nos.:
4. No required additional search fees were timely paid by the applicant. Consequently, this international search report is restricted to the invention first mentioned in the claims; it is covered by claims Nos.:

Remark on Protest

- The additional search fees were accompanied by the applicant's protest and, where applicable, the payment of a protest fee.
- The additional search fees were accompanied by the applicant's protest but the applicable protest fee was not paid within the time limit specified in the invitation.
- No protest accompanied the payment of additional search fees.

FURTHER INFORMATION CONTINUED FROM PCT/ISA/ 210

Continuation of Box II.1

Claims Nos.: 13-17(partially)

Claims 13-17 define methods for non-invasively determining a glucose level in living tissue. However, as detailed on page 5, lines 18-23 and page 15, lines 28-30, embodiments of these methods encompass invasive calibration steps, rendering them methods for treatment of the human or animal body by surgery in the sense of Rule 39.1 (iv) and Rule 67.1 (iv) PCT. The search has been based on those parts of the claims relating to embodiments which do not encompass steps of surgery.

FURTHER INFORMATION CONTINUED FROM PCT/ISA/ 210

This International Searching Authority found multiple (groups of) inventions in this international application, as follows:

1. claims: 1-9, 13

directed to specifying frequency ranges and details of the electrode assembly of a device and method for determining a glucose level in living tissue

2. claims: 10-12, 14-17

directed to specific parameter calculations in a device and method for determining a glucose level in living tissue

INTERNATIONAL SEARCH REPORT

Information on patent family members

International application No

PCT/CH2009/000122

Patent document cited in search report	Publication date	Patent family member(s)	Publication date
WO 2007053963 A1	18-05-2007	EP 1954175 A1 JP 2009514619 T US 2009312615 A1	13-08-2008 09-04-2009 17-12-2009
WO 2005077260 A1	25-08-2005	CA 2555807 A1 US 2005192488 A1 US 2010004517 A1	25-08-2005 01-09-2005 07-01-2010
WO 2005053523 A1	16-06-2005	EP 1694197 A1 JP 2007514474 T US 2010099960 A1	30-08-2006 07-06-2007 22-04-2010
WO 0009996 A1	24-02-2000	AU 5474699 A EP 1021705 A1	06-03-2000 26-07-2000
GB 2428801 A	07-02-2007	NONE	

专利名称(译)	用于葡萄糖测定的宽带场响应测量		
公开(公告)号	EP2429380A1	公开(公告)日	2012-03-21
申请号	EP2009775717	申请日	2009-04-17
申请(专利权)人(译)	BIOVOTION AG		
当前申请(专利权)人(译)	BIOVOTION AG		
[标]发明人	CADUFF ANDREAS TALARY MARK STUART MULLER MARTIN DE FEO OSCAR		
发明人	CADUFF, ANDREAS TALARY, MARK, STUART MÜLLER, MARTIN DE FEO, OSCAR		
IPC分类号	A61B5/00 A61B5/053		
CPC分类号	A61B5/4869 A61B5/01 A61B5/0507 A61B5/0531 A61B5/0537 A61B5/14532 A61B5/1455 A61B2560/0252 A61B2562/043 A61B2562/046		
外部链接	Espacenet		

摘要(译)

用于确定活组织中的葡萄糖水平的方法和设备基于测量组织对电场的响应以及温度测量。为了提高准确度，已经发现，由于组织在这些不同频率范围内的响应，应该在1 kHz和200 kHz之间，0.2 MHz，100 MHz以及1 GHz以上的至少三个频率范围内进行测量。由不同的机制统治。