

(19) World Intellectual Property Organization
International Bureau



(43) International Publication Date
3 December 2009 (03.12.2009)

(10) International Publication Number
WO 2009/144731 A2

- (51) **International Patent Classification:**
A61M 16/04 (2006.01) A61M 16/08 (2006.01)
- (21) **International Application Number:**
PCT/IL2009/000538
- (22) **International Filing Date:**
31 May 2009 (31.05.2009)
- (25) **Filing Language:** English
- (26) **Publication Language:** English
- (30) **Priority Data:**
61/071,959 28 May 2008 (28.05.2008) US
- (71) **Applicant (for all designated States except US):** **ORID-ION MEDICAL 1987 LTD.** [IL/IL]; 7 Hamarpe Street, Har-Hotzvim, 91450 Jerusalem (IL).
- (72) **Inventors; and**
- (75) **Inventors/Applicants (for US only):** **COLMAN, Joshua Lewis** [IL/IL]; 7/3 Patal Street, 97430 Jerusalem (IL). **SHALEV, Iris** [IL/IL]; 12 Hatzav Street, 45858 Mattan (IL).
- (74) **Agents:** **WEBB & ASSOCIATES** et al.; P.O. Box 2189, 76121 Rehovot (IL).
- (81) **Designated States (unless otherwise indicated, for every kind of national protection available):** AE, AG, AL, AM, AO, AT, AU, AZ, BA, BB, BG, BH, BR, BW, BY, BZ, CA, CH, CN, CO, CR, CU, CZ, DE, DK, DM, DO, DZ, EC, EE, EG, ES, FI, GB, GD, GE, GH, GM, GT, HN, HR, HU, ID, IL, IN, IS, JP, KE, KG, KM, KN, KP, KR, KZ, LA, LC, LK, LR, LS, LT, LU, LY, MA, MD, ME, MG, MK, MN, MW, MX, MY, MZ, NA, NG, NI, NO, NZ, OM, PG, PH, PL, PT, RO, RS, RU, SC, SD, SE, SG, SK, SL, SM, ST, SV, SY, TJ, TM, TN, TR, TT, TZ, UA, UG, US, UZ, VC, VN, ZA, ZM, ZW.
- (84) **Designated States (unless otherwise indicated, for every kind of regional protection available):** ARIPO (BW, GH, GM, KE, LS, MW, MZ, NA, SD, SL, SZ, TZ, UG, ZM, ZW), Eurasian (AM, AZ, BY, KG, KZ, MD, RU, TJ, TM), European (AT, BE, BG, CH, CY, CZ, DE, DK, EE, ES, FI, FR, GB, GR, HR, HU, IE, IS, IT, LT, LU, LV, MC, MK, MT, NL, NO, PL, PT, RO, SE, SI, SK, TR), OAPI (BF, BJ, CF, CG, CI, CM, GA, GN, GQ, GW, ML, MR, NE, SN, TD, TG).
- Published:**
— without international search report and to be republished upon receipt of that report (Rule 48.2(g))



WO 2009/144731 A2

(54) **Title:** METHODS, APPARATUS AND SYSTEMS FOR MONITORING CO₂

(57) **Abstract:** There is provided herein methods, apparatus and systems for evaluating carbon dioxide (CO₂) concentration in a subject's breath, for example in subjects ventilated with High Frequency Ventilation (HFV), the method includes inserting to a trachea of a subject an endotracheal tube (ETT), sampling breath from an area in the trachea located in proximity to a distal end of the endotracheal tube (ETT) and evaluating one or more CO₂ related parameters of the sampled breath.

METHODS, APPARATUS AND SYSTEMS FOR MONITORING CO₂

FIELD OF THE INVENTION

The invention generally relates to method and apparatus for monitoring carbon dioxide (CO₂) in breath.

5

BACKGROUND

Continuous noninvasive monitoring of carbon dioxide (CO₂) levels in infants, particularly in a Neonatal Intensive Care Unit (NICU), is considered very important mainly in order to protect subjects such as infants from the complications of hypocarbia (less than the normal level of carbon dioxide in the blood) and hypercarbia (more than the normal level of carbon dioxide in the blood) and to avoid extra blood sampling which may cause anemia, discomfort, and pain. Noninvasive monitoring of carbon dioxide (CO₂) levels typically refers to exhaled breath analysis also referred to as capnography.

Capnography is a common method of monitoring and optionally displaying the CO₂ level(s), CO₂ waveform(s) and/or other CO₂ related parameters, such as End Tidal CO₂ (EtCO₂), in exhaled breath. Capnography also provides information relating to cell metabolism, blood perfusion, alveolar ventilation and other body functions or conditions, and may enable real-time diagnosis of patho-physiological abnormalities as well as technical problems related to ventilation. In intubated subjects (such as patients) capnography is performed by sampling exhaled breath around the exit of the endotracheal tube (ETT) at a sampling region between the proximal end of the ETT (close to the subject's mouth) and the ventilator circuit. In intubated small children and infants, however, capnography is not commonly used since it does not consistently provide satisfactory results. One of the reasons for the lack of satisfactory results in small children, infants and/or neonates especially neonates, relates to the use of uncuffed endotracheal tubes (ETTs) during their ventilation. A cuff is an inflatable balloon on the outer surface of the ETT used to hold the ETT in place and to close off the ventilated air exiting the ETT at its distal end (towards the subject's lung) from escaping around the tube outwards. In case of small children and/or infants, and especially neonates, cuffed

ETT's are generally not used due to the risk of perforating or otherwise harming the gentle membrane of their trachea. The use of uncuffed ETT's results in ventilated air escaping around the tube during inhalation. Although this can be compensated for by changing the ventilator parameters, a greater problem arises during breath sampling (both in mainstream and sidestream capnography) which depends on the exhaled breath returning back through the ETT towards the sampling region. The uncuffed ETT allows the exhaled breath to return between the ETT and trachea, and out through the mouth without returning back through the ETT towards the sampling region. This is further exaggerated, since with neonates the ETT internal diameter is very small, typically between 2.5 to 4mm, which imposes a large restriction, enhancing further the possibility of exhaled breath escaping round the tube. The small volume of exhaled breath (which is only a fraction of the low tidal volumes of infants and neonates) that does manage to return back through the ETT is also diluted with clean ventilated air (often present in a "dead space" of the ETT) which leads to difficult breath sampling and erroneous CO₂ readings.

This problem is further enhanced in mainstream capnography, in which the required airway section is connected inline between the proximal end of the ETT (close to the subject's mouth) and the ventilator circuit. Thus, it adds more dead space, competes for tidal volume, and may also cause a kink in the ETT, especially in small premature infants. When a flow sensor is connected to the ETT, the use of mainstream capnography is even more cumbersome.

There is thus a need in the art for methods, systems and apparatuses that would allow accurate CO₂ monitoring, particularly in small children, infants or neonates.

High Frequency Ventilation (HFV):

In addition to the problems discussed hereinabove, which relates to CO₂ monitoring, the ventilation itself, particularly in neonates, but also with children and adults, still suffers from significant difficulties. Some neonates cannot be adequately ventilated even with sophisticated conventional ventilation. Therefore respiratory insufficiency remains one of the major causes of neonatal mortality. Intensification of conventional ventilation with higher rates and airway pressures leads to an increased incidence of barotrauma.

Especially, the high shearing forces resulting from large pressure amplitudes damage the lung tissue. High Frequency Ventilation (HFV) has been shown to resolve or at least ameliorate this issue in many cases.

High-Frequency Ventilation (HFV) is a technique of ventilation that uses respiratory rates that greatly exceed the rate of normal breathing. There are three main types of HFV:

- 1) High frequency positive pressure ventilation (HPPV, rate 60-150 breaths/minute);
- 2) High frequency jet ventilation (HFJV, rate 100-600 breaths/minute); and
- 3) High frequency oscillatory ventilation (HFOV, rate 300-3000 breaths/minute).

During conventional ventilation direct alveolar ventilation accomplishes pulmonary gas exchange. According to the classic concept of pulmonary ventilation an amount of gas reaching the alveoli equals the applied tidal volume minus the dead space volume. At tidal volumes below the size of the anatomical dead space this model fails to explain gas exchange. Instead, considerable mixing of fresh and exhaled gas in the airways and lungs is believed to be the key to the success of HFV in ventilating the lung at such very low tidal volumes. Among the advantages of high frequency oscillatory ventilation as compared to either conventional positive pressure or jet ventilation is its ability to promote gas exchange while using tidal volumes that are less than dead space. The ability of HFV to maintain oxygenation and ventilation while using minimal tidal volumes allows minimization of barotrauma and thus reduces the morbidity associated with ventilation.

Currently, two of the most important values that determine the respiratory therapy, such as HFV, is the Blood Gas CO_2 (PaCO_2) and the SpO_2 (the amount of oxygen being carried by the red blood cell in the blood). In order to monitor the subject's gas concentration in the blood, however, a blood sample must be taken. Blood sampling involves pain, discomfort and risk of infection. Especially with neonates, since the volume of blood is very small, each blood test takes a measurable percentage of the

neonate's blood. This dictates periodic blood transfusions, where each blood transfusion promotes a further danger to the neonate or other subject.

There is thus a need in the art for methods, systems and apparatuses that would permit and facilitate accurate measurement(s) of medical parameter(s) for the evaluation and control of HFV therapy in subjects, particularly, but not only, in small children, infants or neonates.

SUMMARY

This summary section should not be construed as limiting the invention to any features described in this summary section.

10 General Sampling in Neonatal Environment

Some embodiments of the invention are generally directed to a method and apparatus for monitoring breath carbon dioxide (CO₂) in subjects, particularly, but not limited to, small children and infants, from a position much closer to the bronchial tubes than the current sampling position. This type of CO₂ sampling and evaluation may also be referred to as a "distal CO₂ measurement".

As discussed hereinabove, the current sampling configuration is problematic since it involves sampling from an area close to subject's mouth and to the proximal end of the ETT, wherein CO₂ is mixed with ventilated air, which eventually leads to erroneous CO₂ readings. This is particularly problematic when using an uncuffed endotracheal tube (ETT), which is very common in small children, infants and neonates. It was found that sampling breath from a position at a lower section of the trachea closer to the bronchial tubes (distal CO₂ measurement) may be less susceptible to air leak and/or mixing of the measured CO₂ with inhaled air. More particularly, sampling breath for distal CO₂ measurement may be performed at the distal end of the ETT which is adapted to be positioned inside the bronchial tube. According to some embodiments, sampling breath for distal CO₂ measurement may be performed by inserting a catheter into the ETT, wherein the catheter is adapted to sample CO₂. According to some embodiments, sampling breath for distal CO₂ measurement may be performed by sampling breath

through the second (extra) lumen (typically having a very small diameter compared to the main lumen) of a double lumen ETT.

Sampling in subjects treated with High Frequency Ventilation (HFV):

Additional or alternative embodiments of the invention are generally directed to a method and apparatus for using capnography in monitoring breath carbon dioxide (CO₂) in subjects, particularly, but not limited to, small children and infants, who are ventilated by High Frequency Ventilation (HFV) technique.

When considering capnography for replacing at least some of the blood gas samples, and in general to provide continuous monitoring for HFV (such as HFOV) mode of ventilation, some difficulties arise:

- a) Capnographs are generally designed to detect breath cycles up to rates of about 120-150 breaths per minute. As mentioned above, with HFV, frequencies are much higher. A limiting factor being the response time, which even for the fastest capnograph systems is generally more than 100msec, which is far too slow for this mode of ventilation. In addition, it is most probable, that even if one had a capnograph system that was faster and able to detect changes at frequencies similar to those of the HFV ventilation mode, no breath cycle would be seen Since the CO₂ is mainly diffusing out, and only ripples would be seen caused by the pressure fluctuations.
- b) Capnographs are generally designed such that if a breath cycle (a minimal sinusoidal wave) is not detected, a “no breath” alarm is triggered.
- c) More important, as mentioned herein the considerable mixing of fresh and exhaled gas in the airways and lungs creates a status where the CO₂ concentration along the subject’s airway changes and decreases so that at the standard position for capnography sampling, either mainstream or sidestream, the concentration will be much lower than what is really occurring in the lungs. Hence, CO₂ as currently measured would not be comparative to the blood gas value, and even if it had some correlation, it would have very low resolution. It

was found that the CO₂ concentrations at these standard positions to be about eight times lower than those measured for standard ventilation modes. It is also noted that since there is no breath cycle, the CO₂ concentration is also an average value without peaks.

5 According to some embodiments of the invention, there are provided a method and apparatus that may overcome one or more issues related to difficulties such as those discussed hereinabove, and to facilitate CO₂ sampling and monitoring in subjects (for example, but not limited to, children, infants, and neonates) ventilated by the HFV mode. According to some embodiments of the invention, there are provided a method and
10 apparatus for CO₂ sampling and monitoring in subjects (but not limited to, children, infants, and neonates) ventilated by the HFV mode.

According to some embodiments of the invention, there is provided a method for evaluating concentration of carbon dioxide (CO₂) in a subject's breath, the method includes inserting an endotracheal tube (ETT) to a subject in a need thereof, sampling
15 breath from an area in the trachea located in proximity to a distal end of the endotracheal tube (ETT) and evaluating one or more parameters related to concentration of CO₂ in the sampled breath.

According to some embodiments, sampling breath may include inserting a second tube into the endotracheal tube (ETT), such that the second tube reaches the area located in
20 proximity to the distal end of the endotracheal tube (ETT), and sampling the breath through the second tube.

The endotracheal tube (ETT) may be a double lumen endotracheal tube (ETT) having a main endotracheal tube and a second endotracheal tube, wherein sampling of breath is conducted through the second endotracheal tube. The second endotracheal tube may
25 located essentially inside the lumen of the main endotracheal tube, essentially inside the wall of the main endotracheal tube or partly in both. The second endotracheal tube is located outside the main endotracheal tube. The second endotracheal tube may have a diameter smaller than the diameter of the main endotracheal tube.

According to some embodiments, sampling may further include connecting a sampling line to a connector located at a proximal end of the second endotracheal tube.

According to some embodiments, the method may further include performing suction of fluid from the second endotracheal tube, wherein when suction is performed sampling is temporarily stopped and when sampling is performed suction is stopped.

According to some embodiments, the method may be used in children, infants and/or neonates.

According to some embodiments, the method may be used in subjects ventilated with High Frequency Ventilation (HFV), such as, but not limited to, children, infants and/or neonates.

According to some embodiments of the invention, there is provided a double lumen endotracheal tube (ETT) adapted for sampling breath from a subject for the evaluation of one or more parameters related to concentration of carbon dioxide (CO₂) in the sampled breath, the double lumen endotracheal tube (ETT) includes a main endotracheal tube and a second endotracheal tube, the second endotracheal tube is adapted to sample breath from a distal position in a trachea of a subject. The distal position in a trachea of a subject may include an area of the trachea located in proximity to a distal end of the endotracheal tube (ETT). The distal position in a trachea of a subject may include an area of the trachea located in proximity to a distal end of the second endotracheal tube.

According to some embodiments of the invention, there is provided a breath sampling system including a double lumen endotracheal tube (ETT) adapted for sampling breath from a subject for the evaluation of one or more parameters related to concentration of carbon dioxide (CO₂) in the sampled breath, the double lumen endotracheal tube (ETT) includes a main endotracheal tube and a second endotracheal tube adapted to sample breath from a trachea of a subject in an area located in proximity to a distal end of the endotracheal tube (ETT) and a breath sampling line adapted to connect to the second endotracheal tube of the double lumen endotracheal tube (ETT) through a connector.

The endotrachial tube (ETT) may be a double lumen endotrachial tube (ETT) having a main endotrachial tube and a second endotrachial tube, wherein sampling of breath is conducted through the second endotrachial tube. The second endotrachial tube may be located essentially inside the lumen of the main endotrachial tube, essentially inside the wall of the main endotrachial tube or partly in both. The second endotrachial tube is located outside the main endotrachial tube. The second endotrachial tube may have a diameter smaller than the diameter of the main endotrachial tube.

The second endotrachial tube may include at a proximal end thereof a connector adapted to connect to a sampling line through a sampling opening. The connector may further include a suction port adapted to connect to a fluid suction device and/or to facilitate administration of medical agents. The connector may further include a valve, wherein when the valve is in a first position flow of sampled breath to the sampling line is allowed and the suction port is blocked and when the valve is in a second position the suction port is opened and flow of sampled breath to the sampling line is blocked.

The second endotrachial tube may include at a distal end thereof two or more openings adapted to allow flow of breath to the second endotrachial tube.

The double lumen endotrachial tube (ETT) may be adapted for use with children, infants and/or neonates.

The double lumen endotrachial tube (ETT) may be adapted for use with subjects ventilated with High Frequency Ventilation (HFV), such as, but not limited to, children, infants and/or neonates.

According to some embodiments, the one or more parameters related to concentration of CO₂ may include Spontaneous End tidal CO₂ (S-EtCO₂), Spontaneous final inspired CO₂ (S-FiCO₂), Continuous (Cont. CO₂), Diffusion CO₂ (DCO₂), density of Spontaneous breathing or any trend thereof or any combination thereof.

According to some embodiments, the endotrachial tube (ETT) may be an uncuffed endotrachial tube (ETT).

According to some embodiments of the invention, there is provided a connector adapted to connect a second endotracheal tube of a double lumen endotracheal tube (ETT) to a breath sampling line, the connector includes a connecting element adapted to connect to a second endotracheal tube of a double lumen endotracheal tube (ETT) and a sampling opening adapted to connect to a breath sampling line, wherein the second endotracheal tube is adapted to sample breath, for carbon dioxide (CO₂) concentration monitoring, from an area located in proximity to a distal end of the endotracheal tube (ETT).

The connector may further include a suction port adapted to connect to a fluid suction device and/or to facilitate administration of medical agents.

10 The connector may further include a valve, wherein when the valve is in a first position flow of sampled breath to the sampling line is allowed and the suction port is blocked and when the valve is in a second position the suction port is allowed and flow of sampled breath to the sampling line is blocked.

According to some embodiments of the invention, there is provided a method for evaluating (monitoring) carbon dioxide (CO₂) in breath of a subject ventilated with High Frequency Ventilation (HFV), the method includes sampling breath from a distal area of a trachea of a subject and evaluating one or more CO₂ related parameters. According to some embodiments, sampling may be conducted through an endotracheal tube (ETT). The endotracheal tube (ETT) may be of any form or shape, for example, sampling may be conducted through a second endotracheal tube of a double lumen endotracheal tube (ETT). According to some embodiments, particularly with HFV subjects, distal measurement(s) of CO₂ may be conducted without sampling, but rather by inserting (for example, but not necessarily, through an ETT) one or more CO₂ sensors to a trachea of a subject. The one or more CO₂ related parameters may include Spontaneous End tidal CO₂ (S-EtCO₂), Spontaneous final inspired CO₂ (S-FiCO₂), Continuous CO₂ (Cont. CO₂), Diffusion CO₂ (DCO₂), density of spontaneous breathing or any trend thereof or any combination thereof.

BRIEF DESCRIPTION OF FIGURES

Examples illustrative of embodiments of the invention are described below with reference to figures attached hereto. In the figures, identical structures, elements or parts that appear in more than one figure are generally labeled with a same numeral in all the
5 figures in which they appear. Dimensions of components and features shown in the figures are generally chosen for convenience and clarity of presentation and are not necessarily shown to scale. The figures (FIGs.) are listed below.

Fig. 1 A - C schematically show double lumen Endotracheal Tubes (ETTs), according to some embodiments;

10 **Fig. 2** shows an example of a capnograph display, according to some embodiments;

Fig. 3 A and B show the linear correlation between distal EtCO₂ (dEtCO₂) (**A**) and proximal EtCO₂ (pEtCO₂) (**B**) and arterial CO₂ (PaCO₂), according to some embodiments;

15 **Figs. 4 A and B** present the Bland-Altman plots of the differences between distal EtCO₂ (dEtCO₂) (**A**) and proximal EtCO₂ (pEtCO₂) (**B**) and arterial CO₂ (PaCO₂), according to some embodiments; and

Fig. 5 shows the linear correlation between distal EtCO₂ (dEtCO₂) and arterial CO₂ (PaCO₂) in subjects ventilated with High Frequency Ventilation (HFV), according to some embodiments.

20 DETAILED DESCRIPTION OF EMBODIMENTS

In the following description, various aspects of the invention will be described. For the purpose of explanation, specific configurations and details are set forth in order to provide a thorough understanding of the techniques. However, it will also be apparent to one of skill in the art that the techniques may be practiced without specific details being
25 presented herein. Furthermore, well-known features may be omitted or simplified in order not to obscure the description(s) of the techniques.

According to some embodiments, sampling breath for CO₂ monitoring may be performed from a position much closer to the bronchial tube (at the lower section of the trachea) than the current sampling position. This type of CO₂ sampling and evaluation may also be referred to as a "distal CO₂ measurement". As discussed hereinabove, the current

5 sampling configuration is problematic since it involves sampling from an area close to subject's mouth and to the proximal end of the ETT, wherein CO₂ is mixed with ventilated air, which eventually leads to erroneous CO₂ readings. It was found that sampling breath from a position closer to the bronchial tube (distal CO₂ measurement) may be less susceptible to air leak and/or mixing of the measured CO₂ with inhaled air.

10 More particularly, sampling breath for distal CO₂ measurement may be performed at the distal end of the ETT which is adapted to be positioned inside the bronchial tube. According to some embodiments, sampling breath for distal CO₂ measurement may be performed by inserting a catheter into the ETT, wherein the catheter is adapted to sample CO₂. The catheter may, however, partly occlude or add resistance to the airway.

15 According to some preferred embodiments, sampling breath for distal CO₂ measurement may be performed through the distal part of what is known as a double lumen Endotracheal Tube (ETT). Double lumen ETTs have been used so far as a means for suctioning and administration of surfactants and similar agents. The second (extra) lumen is typically a very small diameter tube which runs within the wall of the first lumen from

20 about half way down to a point close to the distal exit of the ETT.

Reference is now made to **Fig. 1A** which schematically shows a double lumen Endotracheal Tube (ETT), according to some embodiments. Endotracheal Tube (double lumen ETT) 100 includes a main endotracheal tube 102 having a larger diameter and a small diameter tube 104 (for example, approximately 0.8mm) located essentially inside

25 and along the wall of main endotracheal tube 102. Small diameter tube 104 has a distal opening 106 a few millimeters before the distal end 108 (towards the subject's bronchial tube and lungs) of ETT 100. Small diameter tube 104 also includes, at its end opposing distal opening 106, a second opening having a connector 110, adapted to connect to or allow access to suction devices and/or to allow application of agents such as surfactants,

30 medications or the like. According to some embodiments of the invention adapter 110 may be adapted to connect to a sampling line for sampling CO₂ in exhaled breath from

distal end 108 of ETT 100 through small diameter tube 104. Proximal opening 130 of main endotracheal tube 102 is adapted to connect to a ventilator.

According to some embodiments, sampling breath for CO₂ monitoring is performed from the area of the distal end (such as distal end 108) of the double lumen EET (such as double lumen ETT 100). The sampling is performed through the small diameter tube (such as small diameter tube 104) of the double lumen ETT.

Tests clearly showed that for subjects with and without High Frequency Ventilation (HFV) (adults, children, infants and/or neonates) distal CO₂ measurement performed, for example through a double lumen ETT, produced a significantly better or at least comparable correlation and agreement with arterial CO₂. For example, better correlation was obtained between distal EtCO₂ (dEtCO₂) with arterial CO₂ (PaCO₂) than the correlation of pEtCO₂ measured by mainstream or sidestream capnograph sampling at the subject airway proximally with arterial CO₂ (PaCO₂).

Sampling at the distal point of the ETT in subjects and particularly in neonates has another issue: there are many fluids at the distal point. According to some embodiments, in order to solve or reduce the fluid problem and prevent them from reaching the analyzer, a fluid reducing device may be used.

The fluid reducing device may include a standard airway adapter and sampling connector to the sampling line having a stop-cock type valve allowing in its first position to sample breath and in its second position to close the sampling line and open an opening for suction of fluids from the distal section of the trachea.

According to some embodiments, it may be beneficial if the breath sampling opening of the double lumen is several millimeters inside the endotracheal main tube, with possibly several small apertures (hence, if one aperture is covered with fluids, the sampling will continue through one of the remaining openings).

Reference is now made to **Fig. 1B** which schematically shows a double lumen Endotracheal Tube (ETT), according to some embodiments. Endotracheal Tube (double lumen ETT) 200 includes a main endotracheal tube 202 having a larger diameter and a

small diameter tube 204 (approximately 0.8mm) located inside and along the wall of main endotracheal tube 202. Small diameter tube 204 has a distal opening 206 a few millimeters before the distal end 208 (towards the subject's bronchial tube and lungs) of ETT 200. Distal opening 206 of small diameter tube 204 has several (in this case three) additional apertures 209. When one or more of apertures 209 is blocked with fluids, the sampling will continue through one or more of the remaining openings.

Small diameter tube 204 also includes, at its end opposing distal opening 206, a second opening having a connector 210. Connector 210 includes a connecting element 211 adapted to connect to small diameter tube 204. Connector 210 further includes a sampling opening 212 adapted to connect to a sampling line 214, optionally with drying tube 216 adapted to absorb and/or pervaporate fluids present in the sampled breath. Connector 210 also includes suction port 218 through which suction of fluids from the distal section of the trachea can be performed. Suction port 218 may also be adapted to allow application of agents such as surfactants, medications or the like. Connector 210 further includes valve 220. Valve 220 has two optional positions, a first position (as shown in Fig. 1B) allows the flow of air sampled through small diameter tube 204 to drying tube 216 and sampling line 214 and on to the analyzer (such as a capnograph). The second position (not shown) of valve 220 approximately perpendicular to the first position. In the second position, valve 220 blocks the flow of air sampled through small diameter tube 204 to drying tube 216 and sampling line 214 and allow the flow towards suction port 218. Valve 220 (or any other valve) may be adjusted by a user to allow sampling and from time to time, as needed or every period of time, allow suction or application of medication while blocking the sampling path. Proximal opening 230 of main endotracheal tube 202 is adapted to connect to a ventilator. Valve 220 (or any other valve) may also be automatically adjusted by a controller to allow sampling and every period of time trigger suction or application of medication while blocking the sampling path. The controller may also be adapted to stop the sampling pump upon blocking the sampling line.

According to embodiments of the invention, the connector (such as connector 210) may be integrally formed with the second endotracheal tube, which may also be referred to as

small diameter endotracheal tube (such as small diameter tube 204), or may be adapted to be (removably or permanently) affixed or mounted on the proximal end of the second endotracheal tube.

5 According to some embodiments, sampling breath for CO₂ monitoring is performed from the area of the distal end (such as distal end 208) of the double lumen EET (such as double lumen ETT 200). The sampling is performed through the small diameter tube (such as small diameter tube 204) of the double lumen ETT.

10 For clarification and the avoidance of doubt, a "double lumen ETT" or "double lumen endotracheal tube" includes an endotracheal tube with two or more lumens. The two or more lumens may have the same or different internal diameters.

The fluid reducing device may also include a drying tube, such as but not limited to a Nafion® tube or any other drying tube. In case of standard ventilation (where the waveform is analyzed) particularly in infants and neonates, it should be noted that using standard larger water traps, collectors, filters or the like may add extra dead space or
15 minor interference to the breath flow which may effect the waveform.

In case of HFV it may be possible to add filter(s), liquid trap(s), dryer tubes or the like, since in HFV mode response time is less critical compared to standard ventilation, though its (their) size may dampen somewhat the spontaneous breaths.

20 According to some embodiments, one or more of the small diameter tubes of double-lumen ETTs (such as small diameter tubes 104 and 204) may be used for insertion of a sensor or a detector adapted to reach approximately the distal section of the trachea and sense (detect) breath elements such as CO₂. This may replace sampling or conducted in addition to sampling. Such sensor can be a chemical sensor, electronic sensor, optic sensor or any other sensor/detector. For example, the small diameter tubes of a double-
25 lumen ETT may be adapted to receive a fiber optics adapted to transmit and return radiation (for example IR radiation at a wavelength that CO₂ absorbs), and thus detect one or more breath parameters (such as CO₂ levels or waveforms in case of standard ventilation). In another embodiment, radiation (such as light) may be emitted through the

main endotrachial tube (such as main endotrachial tubes 102 and 202) in such way that light entered through the main endotrachial tube is reflected by an appropriate reflector back through an optical fiber in the small diameter tube back to an appropriate detector.

According to some embodiments, there is also provided an ETT, having a main
5 endotrachial tube and a second endotrachial tube (optionally having a smaller diameter than the main endotrachial tube). The second endotrachial tube is located outside the main endotrachial tube (as apposed to inside of the main endotrachial tube as shown above). The distal opening of the second endotrachial tube may be in proximity to the
10 distal opening of the main endotrachial tube but may also be shorter, such that upon insertion to the trachea, it only would only reach the cavity of the mouth for sampling exhaled air that escaped around the uncuffed ETT. This second line may also (as above) connect by a stop-cock to the main (neonatal) sampling adapter. A user could toggle between the two sampling points.

According to some embodiments, the main endotrachial tube may include, at or in
15 proximity to its distal end, a mechanism that is adapted to open when positive pressure from a ventilator pushes in the air for ventilation, while close on exhalation. This way, the exhaled breath will be forced to return around the outside of the main endotrachial tube to be collected by the second endotrachial tube. It is noted however, that a mechanism such as mechanism 340 may apply to standard ventilation, while, in HFV
20 where the main concept is base on diffusion, such mechanism may not be applicable.

Reference is now made to **Fig. 1C** which schematically shows a double lumen Endotrachial Tube (ETT), according to some embodiments. Endotrachial Tube (double lumen ETT) 300 includes a main endotrachial tube 302 and a second endotrachial tube 304 located outside and along the wall of main endotrachial tube 302. Second
25 endotrachial tube 304 has a distal opening 306 at approximately one third of the way of main endotrachial tube 302, so that upon insertion to the trachea, it only would only reach the cavity of the mouth for sampling exhaled air that escaped around uncuffed ETT 300.

Second endotrachial tube 304 also includes, at its end opposing distal opening 306, a second opening having a connector 310. Connector 310 includes a sampling opening 312

adapted to connect to a sampling line 314. Connector 310 also includes suction port 318 through which suction of fluids from the distal section of the trachea can be performed. Suction port 318 may also be adapted to allow application of agents such as surfactants, medications or the like. Connector 310 further includes valve 320. Valve 320 has two optional positions, a first position (as shown in Fig. 1C) allows the flow of air sampled through small diameter tube 304 to sampling line 314 and on to the analyzer (such as a capnograph). The second position (not shown) of valve 320 approximately perpendicular to the first position. In the second position, valve 320 blocks the flow of air sampled through small diameter tube 304 to sampling line 314 and allow the flow towards suction port 318. Valve 320 (or any other valve) may be adjusted by a user to allow sampling and from time to time, as needed or every period of time, allow suction or application of medication while blocking the sampling path. Proximal opening 330 of main endotracheal tube 302 is adapted to connect to a ventilator. Valve 320 (or any other valve) may also be automatically adjusted by a controller to allow sampling and every period of time trigger suction or application of medication while blocking the sampling path. The controller may also be adapted to stop the sampling pump upon blocking the sampling line.

Main endotracheal tube 302 also includes, in proximity to its distal end 308, a mechanism 340 that is adapted to open when positive pressure from a ventilator pushes in the air for ventilation, while close on exhalation. It is noted however, that a mechanism such as mechanism 340 may apply to standard ventilation, while, in HFV where the main concept is base on diffusion, such mechanism may not be applicable. This way, the exhaled breath will be forced to return around the outside of the main endotracheal tube to be collected by the second endotracheal tube.

According to some embodiments, a miniature nano-technology CO₂ sensor may be placed in the trachea through the small diameter tube of the double lumen ETT. This configuration may allow measuring the CO₂ in-situ. According to other embodiments, the CO₂ nano sensor can also be placed in any ETT not necessarily double lumen ETT. Similarly, any other sensor, such as an O₂ sensor may also be placed in (and/or through) the small diameter tube of the double lumen ETT or any ETT in addition or instead of the CO₂ nano sensor. According to some embodiments, the sensor may be disposable.

High Frequency Ventilation (HFV):

Additional or alternative embodiments of the invention are generally directed to a method and apparatus for using capnography in monitoring breath carbon dioxide (CO₂) in subjects, particularly, but not limited to, small children and infants, who are ventilated by
5 High Frequency Ventilation (HFV) technique.

As discussed above when considering capnography for replacing at least some of the blood gas samples, and in general to provide continuous monitoring for HFV (such as HFOV) mode of ventilation, some difficulties arise. These difficulties include very high ventilation frequencies, lack of "clear", "textbook" breath cycle and when sampling at the
10 standard position for capnography, either in mainstream or sidestream, the CO₂ concentration is much lower than what is really occurring in the lungs.

According to some embodiments of the invention, there are provided a method and apparatus for CO₂ sampling and monitoring in subjects (for example, but not limited to, children, infants, and neonates) ventilated by the HFV mode while overcome issues
15 related to difficulties such as those discussed herein.

According to some embodiments of the invention, since in HFV one can expect long periods without observing typical waveforms and breath cycles, which are not the result of apnea, the platform for CO₂ sampling in HFV subjects should take this into account or be insensitive to such instances.

20 New parameters to be provided to the user:

This following describes, according to some embodiments of the invention, possible requirements, improvements and/or changes needed in order to provide an appropriate Capnography mode of operation with subjects ventilated with HFV.

25 According to some embodiments, there are provided new parameters for defining HFV mode. These parameters may optionally have their own alarm management and trend characteristics. Of course, the names given to these parameters are not binding and are only optional.

According to some embodiments, the following parameters may be defined and used for capnography in subjects ventilated with HFV. Some of these parameters may be used instead of or in addition to standard respiratory rate (RR), EtCO₂ parameters or other known standards.

5

a) Cont.CO₂ - Continuous CO₂: According to some embodiments, this is a main value used in HFV capnography and can be calculated as the average CO₂ reading (concentration) over the last “x” seconds (which could be 5 seconds or 1 to 60 seconds or any other period), updated every “y” second (“y” could be 1 to 60 seconds or any other period). If within this period a spontaneous breath is detected or even the possible beginning of such a breath is suspected (to be defined in section “e” below), then the last Cont.CO₂ value could be frozen until a new period (such as, a 5-second period) has passed without any identified spontaneous breath. If the spontaneous breaths continue for more than possibly “z” seconds (such as, 60 seconds) without a “w” second (for example, 15 5 second) gap, the Cont. CO₂ value may be determined and optionally displayed as invalid (for example a dash is provided in place of the value).

b) S-EtCO₂ - Spontaneous EtCO₂: If a spontaneous breath cycle (to be defined in section “e” below) is recognized (typically a result of spontaneous breathing), then, according to some embodiments, the highest CO₂ (concentration) value of the breath, S-EtCO₂ (Spontaneous EtCO₂), may be measured and optionally displayed. The displayed value may be the highest result that was collected over the last “m” seconds (possibly 1 to 20 60 seconds). Again, it may be updated every period of time (once a second for example). If for “n” seconds (for example, 20 seconds) there is no new breath, the S-EtCO₂ value may be determined and optionally displayed as invalid (for example a dash is provided in 25 place of the value).

c) S- FiCO₂ - Spontaneous fractional concentration of final inspired CO₂: If a breath cycle is recognized, then, according to some embodiments, the lowest CO₂ (concentration) value in the breath cycle (Spontaneous fractional concentration of final inspired CO₂, S-FiCO₂) may be used and the value obtained and optionally displayed 30 being the lowest collected over the last “u” seconds (possibly 1 to 60 seconds). Again, it

may be updated every period of time (once a second for example). If for "t" seconds (for example, 20 seconds) there is no new breath, the S-EtCO₂ value may be determined and optionally displayed as invalid (for example a dash is provided in place of the value).

5 d) DCO₂ – Diffusion (gas transport coefficient) CO₂, DCO₂: This parameter may be similar to the conventional ventilation parameter that is the product of tidal volume and frequency, known as minute ventilation, which aptly describes pulmonary gas exchange. The gas transport coefficient which defines the CO₂ elimination correlates to the product of “oscillatory volume” squared and the frequency. For this purpose, it would be necessary to enable entering of the HFV ventilator parameters into the Capnograph.

10 e) Inst. CO₂ - Instantaneous CO₂: a raw unprocessed measurement of CO₂. According to some embodiments, every period of time (for example, once every 50msec, a CO₂ measurement is performed). If the measured CO₂ change of at least “c” mmHg (“c” can for example be between 1 and 10mmHg) above (or below) the Cont.CO₂ current (latest) value and lasting for at least "k" milliseconds, msec (for example, 200msec), a
15 spontaneous breath is suspected. The system may trace for a peak to peak (PTP) of “c” mmHg lasting more than a minimal "k" period, for example 200 msec. During this stage the Cont.CO₂ value may be frozen as stated above. In case of a timeout (of for example, 3 seconds) with no “c” mmHg PTP, the PTP trace may be stopped and the Cont.CO₂ calculation may be resumed. A spontaneous breath is counted every 2 consecutive
20 occurrences of “c” mmHg PTP.

f) “Low CO₂”: Since in HFV one can expect long periods without observing a typical waveforms and breath cycles, there is no meaning to the term “apnea” or “no breath”, hence the term “low CO₂” may be used instead.

g) High and low Cont. CO₂ alarms: According to some embodiments, the alarms relating
25 to RR, high and low EtCO₂ may be disabled and Cont. CO₂ high and low may be enabled.

h) Density of spontaneous breaths: According to some embodiments the Density of spontaneous breaths may be calculated. This value may be obtained by calculating what percentage of the time the subject is spontaneously breathing

i) According to some embodiments, trends of any CO₂ related parameter (such as Cont. CO₂) may be provided and optionally presented as a graph or table that demonstrates the change of the parameter over time.

j) According to some embodiments, the Cont. CO₂ value may be displayed at a position where in normal mode (non-HFV) the EtCO₂ value is displayed. The other two parameters (S-EtCO₂ and FiCO₂) may be displayed where in normal mode (no-HFV) the RR and FiCO₂ are displayed.

k) According to some embodiments, the display may include two parts:

1) A main waveform display having a sweep rate which is slower than the standard ventilation (non-HFV) generally in the range of 0.1 to 10 mm/second. This mode displays the Continuous (Cont. CO₂) with the sporadic spontaneous breaths superimposed on it. An example of a main waveform display can be seen in the top graph of Fig. 2, which shows an example of a capnograph display of a subject ventilated by HFV, according to some embodiments. The top graph shows the values of Cont. CO₂ in mmHg over time (seconds, sec). The sections of the graph having clear "dips" indicate spontaneous breathing.

2) A display having a slower sweep rate than that of the main waveform display (section 1 hereinabove), for example in the range of 0.1 to 10mm/min. This slower display shows the trend of the Continuous (Cont. CO₂), or in other words, how the Cont. CO₂ is changing over a period of time (for example, 90 min). This type of data may reduce or even eliminate the use of blood gas, since, for example, just by looking at it the doctor may know if the CO₂ level is improving since the last blood gas test obtained from the subject. An example of such a trend display can be seen in the bottom graph of Fig. 2, which shows the trend of Cont. CO₂ in mmHg over time (minutes, min). In addition to

these graphs, values of Cont. CO₂, S-EtCO₂, S-FiCO₂ as well as SpO₂ and PR (pulse oximetry) may also be presented.

l) According to some embodiments, there is provided a means for manually (or automatically) entering an event mark, for example, defining a blood gas. A red spot, for example, or similar (possibly a sigh, a letter or a combination of letters such as "b.g.") may be placed on the slower trend display so that the doctor can easily see trends of CO₂ relative to the last blood gas time. It is preferred that one could also add the values of the blood gas in any form (values, graphical etc.) so that they can be displayed on the trend with the sampled CO₂ values.

10 According to some embodiment of the invention, the term "distal" or "distal end" may refer to a position located (or adapted to be located) towards a subject's lungs.

According to some embodiment of the invention, the term "proximal" or " proximal end" may refer to a position located (or adapted to be located) towards a subject's mouth.

15 According to some embodiment of the invention, the term "main endotrachial tube" may refer to a part of an endotracheal tube through which ventilation may be performed.

According to some embodiment of the invention, the term "second endotrachial tube" may refer to a part of an endotracheal tube which is not directly used for ventilation. A second endotrachial tube may be smaller in diameter than the main endotrachial tube. A second endotrachial tube may be integrally formed with the main endotrachial tube or connected thereto.

20 According to some embodiment of the invention, the term "sampling line" or "breath sampling line" may refer to any type of tubing(s) or any part of tubing system adapted to allow the flow of sampled breath, for example, to an analyzer, such as a capnograph. The sampling line may include tubes of various diameters, adaptors, connectors, valves, drying elements (such as filters, traps, trying tubes, such as Nafion® and the like).

EXAMPLES

EXAMPLE 1: Correlation between sampling through a double lumen ETT and blood gas

5 *Study design*

A prospective observational study was conducted at Bnai-Zion Medical Center, Haifa, Israel. Infants were connected simultaneously to proximal and distal EtCO₂ monitors, and the measurements were compared to PaCO₂ drawn for patient care. Measurements of distal EtCO₂ (dEtCO₂) were not used for patients' clinical care. The study was approved
10 by the institutional review board. All the parents signed an informed consent prior to participating in the study.

The primary outcome measure was to evaluate the accuracy and the correlation of Microstream dEtCO₂ with the gold standard of PaCO₂. The secondary outcome measure was to compare these findings to the more standard and commonly used method of
15 mainstream pEtCO₂.

Study population

Included in the study were all intubated infants in the NICU during the study period, who had the double lumen endotracheal tubes (ETT) and that their parents signed an informed consent. Excluded were infants with a single lumen endotracheal tube.

20 All infants who needed an ETT were intubated in the delivery room or in the NICU by a double lumen tube (Uncuffed Tracheal Tube, Mallinckrodt Inc., Chih, Mexico). This ETT has an extra small lumen for administration of exogenous surfactant or for measurements of distal pressures close to the carina. In this study this side port was used to measure dEtCO₂ only.

25 Intubated infants were monitored by the two capnograms simultaneously. The side-stream dETCO₂ was measured distally by a Microstream capnograph via a Microstream cannula (Oridion Medical Inc., Needham, MA). The main-stream pETCO₂ was measured via capnogram connected to the proximal end of the ETT (Philips IntelliVue patient

monitor, Capnography Extension M3014A, Philips, Boeblingen, Germany). Readings from the two methods were charted at the time of blood sampling for routine patient care via an indwelling arterial line and compared to PaCO₂ level (Omni AVL, Roche Diagnostic GmbH, Graz, Austria). Before each blood sampling it was assured that an adequate reading of pEtCO₂ and a reliable waveform on the Microstream capnograph (continuous steady waveform of expired CO₂ throughout the ventilatory cycle), and cleared secretions from the side port of the ETT for dEtCO₂ measurement (by inserting 5 ml of air). Microstream cannulas blocked by secretions were replaced as needed.

Data on the patients' characteristics, type of their pulmonary or cardiac disease and the severity of pulmonary disease (by oxygenation index defined as fractional inspired of oxygen [FiO₂] X mean airway pressure/PaO₂ and by the level of ventilation perfusion mismatch assessed by PaO₂/PAO₂ ratio) was collected. Severe lung disease was defined as: PaO₂/PAO₂ ratio < 0.3 (18, 19) or OI > 10; mild-moderate lung disease: PaO₂/PAO₂ ratio > 0.3 and OI < 10 (PAO₂ was calculated by: FiO₂ X [Barometric pressure-47] - PaCO₂/0.8]. PaCO₂ was assumed the same as alveolar PACO₂.

A bias ≤ 5 mmHg was considered a low bias and >5 mmHg a high bias (9, 10).

The consistency of EtCO₂ monitoring (proximal and distal) within each patient was assessed by examining the relationship between the change in PaCO₂ and the change EtCO₂ in consecutive samples.

20 *Statistical analysis*

The correlation of distal and proximal EtCO₂ and PaCO₂ was evaluated by linear regression analysis and assessed the agreement between these measurements (bias [mean difference] and precision [standard deviation of the differences]) by the Bland-Altman technique (22).

25 The correlation between the changes in PaCO₂ and the simultaneous changes in proximal and distal EtCO₂ were evaluated for consecutive measurements within each patient by linear regression analysis.

Level of significance was set at $p < 0.05$. SigmaStat version 2.03, Chicago, IL and the Minitab version 12.23, State College, PA statistical softwares were employed.

Results

Twenty-seven infants participated in the study and 222 measurements of distal EtCO₂ and 212 of proximal EtCO₂ were analyzed. In 10 infants proximal EtCO₂ could not be measured continuously. **Table 1** shows the characteristics of the patients who participated in the study.

Table 1: Patients' characteristics (n=27)

	Median	Range
10		
Gestational age (weeks)	32.5	(24.8-40.8)
Birth weight (g)	1835	(490-4790)
Age of enrolment (days)	1	(1-26)
Number of observations	8	(1-24)
15		
pH	7.34	6.5-7.5
FiO ₂ *	0.31	0.21-1.00
PaO ₂ /PAO ₂ ratio**	0.50	0.06-2.38
Oxygenation index (OI)***	3.29	0.63-23.0
Primary diagnosis (n=27 infants)		
20		
Respiratory distress syndrome		19
Tracheo-esophageal fistula and esophageal atresia		3
Pneumonia		1
Primary pulmonary hypertension		1
Meconium aspiration syndrome		1

Hypoxic ischemic encephalopathy	1
Necrotizing enterocolitis	1

* FiO₂ Inspired oxygen fraction;

5 ** PaO₂/PAO₂ alveolar/arterial oxygen tension ratio;

*** OI = FiO₂ X mean airway pressure/PaO₂

The median (range) levels of PaCO₂, dEtCO₂, pEtCO₂ were 46.3 (24.5-99.7) mmHg, 46.0 (20.0-98.0) mmHg, and 37.0 (12.0-71.0) mmHg, respectively.

10 **Figs. 3 A and B** show the linear correlation between distal EtCO₂, dEtCO₂ (**A**) and proximal EtCO₂, pEtCO₂ (**B**) with arterial PCO₂, according to some embodiments. While the correlation coefficient (r) of dEtCO₂ and PaCO₂ was adequate (r = 0.72, p< 0.001), the r of the pEtCO₂ was poor (r = 0.21, p=0.002).

15 **Figs. 4 A and B** present the Bland-Altman plots of the differences between distal EtCO₂, dEtCO₂ (**A**) and proximal EtCO₂, pEtCO₂ (**B**) and arterial CO₂, PaCO₂, according to some embodiments. The mean difference (bias) and the standard deviation of the differences (precision) for the dEtCO₂ were -1.5±8.7 mmHg, and for the pEtCO₂ -10.2±13.7 mmHg, respectively. The correlating medians (25 and 75 percentiles) were: -1.1 (-5.6 and 2.7) and -10.3 (-16.0 and -0.8), respectively. Although both, distal and proximal EtCO₂ levels
20 underestimated the PaCO₂ level, dEtCO₂ was more accurate than pEtCO₂ as a non-invasive measure of PaCO₂.

dEtCO₂ (21 samples) remained reliable as a measure of PaCO₂, while pEtCO₂ (19 samples) was distorted on the high range of PaCO₂ levels (≥60 mmHg) (r = 0.77, p<0.001 and r = 0.21, p = 0.38; bias ± precision: -4.8±7.9 and -33.3±20.0; respectively).

25 **Table 2** shows the effect of the severity of pulmonary disease (assessed by PaO₂/PAO₂ ratio or by OI) on the accuracy of distal and proximal EtCO₂ readings. It was found that

dETCO₂ still correlated with PaCO₂, but its bias increased with the severity of pulmonary disease.

Table 2: Relation between EtCO₂ values and severity of lung disease

	Mild to Moderate	Severe lung disease
	<u>Mean (SD); r, p value</u>	<u>Mean (SD); r, p value</u>
5		
	PaO ₂ /PAO ₂ ratio >0.3 (n=168)	≤0.3 (n=63)
	P (Et-a distal) CO ₂ -0.24±7.3; 0.74, <0.001	-4.2±10.5; 0.64, <0.001
	P (Et-a proximal) CO ₂ -9.1±14.0; 0.07, =0.34	-12.5±12.5; 0.35, <0.01
10	Oxygenation index <10 (n=216)	≥10 (n=16)
	P (Et-a distal) CO ₂ -0.7±8.2; 0.69, <0.001	-9.0±8.1; 0.77, <0.001
	P (Et-a proximal) CO ₂ -9.8±13.9; 0.13, =0.07	-13.0±9.8; 0.52, =0.054

All CO₂ levels in mmHg

15

The changes in PaCO₂, and the simultaneous changes in proximal and distal EtCO₂ were evaluated for consecutive measurements within each patient. The mean changes in PaCO₂ were 0.12±9.3 mmHg and in dEtCO₂ 0.90±10.8 mmHg, with r between the changes of 0.49, p<0.001. Mean change in pEtCO₂ was -0.02±8.5 mmHg, with r of 0.17, p<0.05, compared to the simultaneous changes in PaCO₂.

20

This study shows that the novel method of measuring dEtCO₂ through a double-lumen ETT had a better correlation and agreement with PaCO₂ when compared to the standard mainstream pEtCO₂ method in neonates. The accuracy of dEtCO₂ decreased but it remained a reliable measure of PaCO₂ even in the high range of PaCO₂ (≥60 mmHg) or in conditions of severe lung disease.

25

It was found that dEtCO₂ was an accurate and reliable non-invasive method for estimating PaCO₂. It had a good correlation with PaCO₂ (n = 222, r = 0.72, p<0.001), which was slightly lower compared to mainstream pEtCO₂ (n = 411, r = 0.83, p<0.001) as previously reported for NICU infants by Rozycki *et al* (10). The bias reported for dEtCO₂ (-1.5±8.7 mmHg) was even smaller than that reported by Rozycki *et al* for mainstream pEtCO₂ (-6.9±6.9 mmHg), and was well < 5 mmHg, which is considered within the good agreement range (9, 10). In the study, the correlation and the agreement of dEtCO₂ with PaCO₂ were better than those for mainstream pEtCO₂. Several investigators reported similar results for distal and proximal sidestream EtCO₂ (17, 18) while others reported comparable accuracy of distal and proximal mainstream EtCO₂ (11). However, neither of these studies measured dEtCO₂ by a double lumen ETT, nor did they use the Microstream technique. The study results regarding the mainstream pEtCO₂ should be interpreted with caution, as others reported better results for that method (10). This could result from different conditions in the different studies reflected by mixture of patients, severity of their lung disease, levels of leak around the ETT, and instrumentation used for measurements.

Severity of disease was reported to affect the accuracy of capnometry in several studies. The more severe the ventilation perfusion mismatch, the higher the difference between EtCO₂ and PaCO₂ (9, 20). Parenchymal lung disease with ventilation perfusion mismatching is a common feature in NICUs. Sivan *et al* (20) reported that PaO₂/PAO₂ ratio > 0.3 was associated with better agreement between EtCO₂ and PaCO₂ and Hagerty *et al* (9) found a higher gradient between EtCO₂ and PaCO₂ when comparing newborn with pulmonary disease and those receiving mechanical ventilation for non-pulmonary conditions. Different results were reported by other investigators. Tingay *et al* (19) found that the EtCO₂ bias was independent of severity of lung disease and Rozycki *et al* (10) reported that measures of degree of lung disease (ventilation index and oxygenation index) had small influence on the degree of bias. In the study the agreement of dEtCO₂ and PaCO₂ decreased, but the bias in patients with PaO₂/PAO₂ ratio < 0.3 remained < 5 mmHg. It was assessed whether the level of PaCO₂ affected the accuracy of EtCO₂ readings, and found it to affect the pEtCO₂ much more than the dEtCO₂, which remained with adequate agreement with the PaCO₂. Rozycki *et al* did not find that the accuracy of

pEtCO₂ was affected by the PaCO₂ level (10). The findings suggest that dEtCO₂ as evaluated in the study could be used as a reliable non-invasive method for PaCO₂ assessment in the full spectrum of NICU patients.

Although the Microstream sidestream capnography was used previously in (only) two studies in newborns (9, 19), this is the first time a double lumen ETT is used for the disclosed purpose, which allowed continuous measurement of dEtCO₂ via its extra lumen.

The intention of the Microstream technique is to improve the accuracy of sidestream capnometry which is traditionally considered less accurate than the mainstream capnometry (11, 13, 14, 15, 16). Microstream capnography employs a sampling flow rate of 50 ml/min, approximately one third of that used by previous studies with conventional sidestream systems. This low flow rate eliminates the competition for tidal volume and also decreases condensation within the system. Because of the highly CO₂ – specific infrared source (emission that exactly matches the absorption spectrum of the CO₂ molecule), the sample cell utilizes a much smaller volume (15 µl) that permits a low flow rate without compromising response rate or accuracy. These features preserve accuracy by preventing mixing of the small inspiratory and expiratory volumes observed in newborns, while rapid response time is maintained by laminar gas flow throughout the breathing circuit (22). The new low-flow sidestream capnograph (Oridion Medical Inc., Needham, MA, USA) was tested when connected to the side port of the proximal ETT by Hagerty *et al* (9), and they reported a gradient of 3.4±2.4 mmHg in ventilated infant without pulmonary disease and 7.4±3.3 in those with pulmonary disease. Tingay *et al* (19) also used the Microstream technique (Agilent Microstream system, Andover, Massachusetts, USA) for monitoring pEtCO₂ in infants during neonatal transport. They reported that the pEtCO₂ had a linear relation with PaCO₂ but had an unacceptable underestimation of PaCO₂ (8.2±5.2 mmHg), and did not trend reliably over time within an individual patient. In the study, using the Microstream technique (Oridion Medical Inc., Needham, MA, USA), but measuring dEtCO₂ via the side port of the double lumen ETT, the agreement with PaCO₂ improved, in infants with both mild and severe pulmonary disease (-0.24±7.3, and -4.2±10.5; respectively). The improvement could be

related to distal measurements of EtCO₂. This technique which measures EtCO₂ close to the carina, may be less affected by the ventilatory circuit flow and leaks around the uncuffed ETTs used in neonates and thus better represent the accurate PaCO₂. dEtCO₂ as opposed to pEtCO₂ are not affected by flow sensors which are commonly used nowadays
5 with the new ventilators (flow sensors in the study prevented the use of pEtCO₂ in few infants because of inadequate continuous measurements).

The novel method of measuring dEtCO₂ via a double-lumen endotracheal tube was found to have good correlation and agreement with PaCO₂, and is thus a reliable in conditions of severe lung disease. dEtCO₂ was more accurate than the standard mainstream pEtCO₂
10 method as assessed in the study. EtCO₂ does not replace PaCO₂, but may be useful for trending and for real time continuous screening of abnormal PaCO₂ levels. As noninvasive CO₂ monitoring may be of importance for the short and long term outcome of intubated neonates, and as the current available methods are limited, medical teams should consider the use of this non-invasive method of assessing PaCO₂ in NICUs.

15 **EXAMPLE 2: Correlation between sampling through a double lumen ETT and blood gas in patients ventilated by HFV**

Eight patients ventilated by HFV were tested, comparing mainstream capnography to Microstream capnography wherein the sampling line is connected to the distal end of a double lumen ETT. In most of the cases 2.5mm ETT (internal diameter of the main
20 endotracheal tube) were used. Correlation to blood gas was used as the reference.

Continuous distal sampling with minor liquid issues was conducted (without having to toggle). Further, two Nafion® pieces were placed along the sampling line, one next to the double lumen connector, and one about 40cm down the line. The second Nafion® was used since often the neonate is in a controlled humidified incubator, and hence one
25 Nafion® must be placed also in the outside environment. The results are described in **Fig. 5** which shows the linear correlation between distal EtCO₂, dEtCO₂ and arterial CO₂, PaCO₂ in patients ventilated with High Frequency Ventilation (HFV), according to some embodiments. The correlation between dEtCO₂ and PaCO₂ was shown to be much better than the correlation between pEtCO₂ and PaCO₂.

In the description and claims of the application, each of the words “comprise” “include” and “have”, and forms thereof, are not necessarily limited to members in a list with which the words may be associated.

The invention has been described using various detailed descriptions of embodiments thereof that are provided by way of example and are not intended to limit the scope of the invention. The described embodiments may comprise different features, not all of which are required in all embodiments of the invention. Some embodiments of the invention utilize only some of the features or possible combinations of the features. Variations of embodiments of the invention that are described and embodiments of the invention comprising different combinations of features noted in the described embodiments will occur to persons with skill in the art. It is intended that the scope of the invention be limited only by the claims and that the claims be interpreted to include all such variations and combinations.

REFERENCES, included herein by reference in their entirety:

1. Garland JS, Buck RK, Allred EN, Leviton A. Hypocarbica before surfactant therapy appears to increase bronchopulmonary dysplasia risk in infants with respiratory distress syndrome. *Arch Pediatr Adolesc Med* 1995; 149(6):617-22
- 5 2. Fujimoto S, Togari H, Yamaguchi N, Mizutani F, Suzuki S, Sobajima H. Hypocarbica and cystic periventricular leukomalacia in premature infants. *Arch Dis Child* 1994; 71(2):F107-10
3. Wyatt JS, Edwards AD, Cope M, Delpy DT, McCormick DC, Potter A, Reynolds EO. Response of cerebral blood volume to changes in arterial carbon dioxide
10 tension in preterm and term infants. *Pediatr Res* 1991; 29(6):553-7
4. Van de Bor M, Van Bel F, Lineman R, Ruys JH. Perinatal factors and periventricular-intraventricular hemorrhage in preterm infants. *Am J Dis Child* 1986; 140(11):1125-30
5. Strauss RG. Transfusion therapy in neonates. *Am J Dis Child* 1991; 145(8):904-
15 11 . Review.
6. Bhende MS. End-tidal carbon dioxide monitoring in pediatrics - clinical applications. *J Postgrad Med* 2001; 47(3):215-8. Review
7. Wyllie J, Carlo WA. The role of carbon dioxide detectors for confirmation of endotracheal tube position. *Clin Perinatol* 2006; 33(1):111-9, vii. Review
- 20 8. Current limitations of volumetric capnography in surfactant-depleted small lungs. *Pediatr Crit Care Med* 2004; 5(1):75-80

9. Hagerty JJ, Kleinman ME, Zurakowski D, Lyons AC, Krauss B. Accuracy of a new low-flow sidestream capnography technology in newborns: a pilot study. *J Perinatol* 2002; 22(3):219-25
10. Rozycki HJ, Sysyn GD, Marshall MK, Malloy R, Wiswell TE Mainstream end-tidal carbon dioxide monitoring in the neonatal intensive care unit. *Pediatrics* 1998; 101(4 Pt 1):648-53
11. McEvedy BA, McLeod ME, Kirpalani H, Volgyesi GA, Lerman J. End-tidal carbon dioxide measurements in critically ill neonates: a comparison of side-stream and mainstream capnometers. *Can J Anaesth* 1990; 37(3):322-6
- 10 12. Wu CH, Chou HC, Hsieh WS, Chen WK, Huang PY, Tsao PN. Good estimation of arterial carbon dioxide by end-tidal carbon dioxide monitoring in the neonatal intensive care unit. *Pediatr Pulmonol* 2003; 35(4):292-5
13. Pascucci RC, Schena JA, Thompson JE. Comparison of sidestream and mainstream capnometer in infants. *Crit Care Med* 1989; 17: 560-562
- 15 14. Hand IL, Shepard EK, Krauss AN, Auld PA. Discrepancies between transcutaneous and end-tidal carbon dioxide monitoring in the critically ill neonate with respiratory distress syndrome. *Crit Care Med* 1989; 17(6):556-9
- 20 15. Kirpalani H, Kechagias S, Lerman J. Technical and clinical aspects of capnography in neonates. *J Med Eng Technol* 1991; 15:154-61

16. Schieber RA, Namnoum A, Sugden A, Saville AL, Orr RA. Accuracy of expiratory carbon dioxide measurements using the coaxial and circle breathing circuits in small subjects. *J Clin Monit* 1985; 1:149-55
17. Badgwell JM, McLeod ME, Lerman J, Creighton RE. End-tidal PCO₂ measurements sampled at the distal and proximal ends of the endotracheal tube in infants and children. *Anesth Analg* 1987; 66(10):959-64
18. McEvedy BA, McLeod ME, Mulera M, Kirpalani H, Lerman J. End-tidal, transcutaneous and arterial CO₂ measurements in critically ill neonates: a comparative study. *Anesthesiology* 1988; 69:112-6 .
19. Tingay DG, Stewart MJ, Morely CJ. Monitoring of end tidal carbon dioxide and transcutaneous carbon dioxide during neonatal transport. *Arch Dis Child Fetal Neonatal Ed* 2005; 90:F523-F526 .
20. Sivan Y, Eldadah MK, Cheah TE, Newth CJ. Estimation of arterial carbon dioxide by end-tidal and transcutaneous PCO₂ measurements in ventilated children. *Pediatr Pulmonol* 1992; 12:53-7
21. Bland JM, Altman DG. Statistical methods for assessing agreement between two methods of clinical measurement. *Lancet* 1986; 1:307-10
22. Colman Y, Krauss B. Microstream capnography technology: a new approach to an old problem. *J Clin Monit* 1999; 15:403-9
23. Palmisiano BW, Severinghaus JW. Transcutaneous PCO₂ and PO₂: a multicenter study of accuracy. *J Clin Monitor* 1990; 6:189-195

24. Rennie JM. Transcutaneous carbon dioxide monitoring. *Arch Dis Child* 1990;
65:345-346

CLAIMS

What is claimed is:

1. A method for evaluating concentration of carbon dioxide (CO₂) in a subject's breath, the method comprising:
 - 5 inserting an endotrachial tube (ETT) to a subject in a need thereof;

sampling breath from an area in the trachea located in proximity to a distal end of the endotrachial tube (ETT); and

evaluating one or more parameters related to concentration of CO₂ in the sampled breath.
- 10 2. The method of claim 1, wherein sampling breath comprises inserting a second tube into the endotrachial tube (ETT), such that the second tube reaches the area located in proximity to the distal end of the endotrachial tube (ETT), and sampling the breath through the second tube.
- 15 3. The method of claim 1, wherein the endotrachial tube (ETT) is a double lumen endotrachial tube (ETT) having a main endotrachial tube and a second endotrachial tube, wherein sampling of breath is conducted through the second endotrachial tube.
- 20 4. The method of claim 3, wherein the second endotrachial tube is located essentially inside the lumen of the main endotrachial tube, essentially inside the wall of the main endotrachial tube or partly in both.
5. The method of claim 3, wherein the second endotrachial tube is located outside the main endotrachial tube.
6. The method of claim 3, wherein the second endotrachial tube has a diameter smaller than the diameter of the main endotrachial tube.

7. The method of claim 3, wherein sampling further comprises connecting a sampling line to a connector located at a proximal end of the second endotrachial tube.
8. The method of claim 3, further comprising performing suction of fluid from the second endotrachial tube, wherein when suction is performed sampling is temporarily stopped and when sampling is performed suction is stopped.
9. The method of claim 1, for use with children, infants and/or neonates.
10. The method of claim 1, for use with subjects ventilated with High Frequency Ventilation (HFV).
11. The method of claim 10, wherein the one or more parameters related to concentration of CO₂ comprise Spontaneous End tidal CO₂ (S-EtCO₂), Spontaneous final inspired CO₂ (S-FiCO₂), Continuous (Cont. CO₂), Diffusion CO₂ (DCO₂), density of Spontaneous breathing or any trend thereof or any combination thereof.
12. The method of claim 1, wherein the endotrachial tube (ETT) is an uncuffed endotrachial tube (ETT).
13. A double lumen endotrachial tube (ETT) adapted for sampling breath from a subject for the evaluation of one or more parameters related to concentration of carbon dioxide (CO₂) in the sampled breath, the double lumen endotrachial tube (ETT) comprising:
- a main endotrachial tube; and
 - a second endotrachial tube adapted to sample breath from a distal position in a trachea of a subject.
14. The double lumen endotrachial tube (ETT) of claim 13, wherein the second endotrachial tube is located essentially inside the lumen of the main endotrachial tube, essentially inside the wall of the main endotrachial tube or partly in both.

15. The double lumen endotracheal tube (ETT) of claim 13, wherein the second endotracheal tube is located outside the main endotracheal tube.
16. The double lumen endotracheal tube (ETT) of claim 13, wherein the second endotracheal tube has a diameter smaller than the diameter of the main endotracheal tube.
- 5
17. The double lumen endotracheal tube (ETT) of claim 13, wherein the second endotracheal tube comprises at a proximal end thereof a connector adapted to connect to a sampling line through a sampling opening.
18. The double lumen endotracheal tube (ETT) of claim 17, wherein the connector further comprises a suction port adapted to connect to a fluid suction device and/or to facilitate administration of medical agents.
- 10
19. The double lumen endotracheal tube (ETT) of claim 18, wherein the connector further comprises a valve, wherein when the valve is in a first position flow of sampled breath to the sampling line is allowed and the suction port is blocked and when the valve is in a second position the suction port is opened and flow of sampled breath to the sampling line is blocked.
- 15
20. The double lumen endotracheal tube (ETT) of claim 13, wherein the second endotracheal tube comprises at a distal end thereof two or more openings adapted to allow flow of breath to the second endotracheal tube.
- 20
21. The double lumen endotracheal tube (ETT) of claim 13, adapted for use with children, infants and/or neonates.
22. The double lumen endotracheal tube (ETT) of claim 13, adapted for use with subjects ventilated with High Frequency Ventilation (HFV).
23. The double lumen endotracheal tube (ETT) of claim 22, wherein the one or more parameters related to concentration of CO₂ comprise Spontaneous End tidal CO₂ (S-EtCO₂), Spontaneous final inspired CO₂ (S-FiCO₂), Continuous CO₂ (Cont.
- 25

CO₂), Diffusion CO₂ (DCO₂), density of Spontaneous breathing or any trend thereof or any combination thereof.

24. The double lumen endotracheal tube (ETT) of claim 13, wherein the endotracheal tube (ETT) is an uncuffed endotracheal tube (ETT).

5 25. A breath sampling system comprising:

10 a double lumen endotracheal tube (ETT) adapted for sampling breath from a subject for the evaluation of one or more parameters related to concentration of carbon dioxide (CO₂) in the sampled breath, the double lumen endotracheal tube (ETT) comprises a main endotracheal tube and a second endotracheal tube adapted to sample breath from a trachea of a subject in an area located in proximity to a distal end of the endotracheal tube (ETT); and

a breath sampling line adapted to connect to the second endotracheal tube of the double lumen endotracheal tube (ETT) through a connector.

15 26. The system of claim 25, wherein the second endotracheal tube is located essentially inside the lumen of the main endotracheal tube, essentially inside the wall of the main endotracheal tube or partly in both.

27. The system of claim 25, wherein the second endotracheal tube is located outside the main endotracheal tube.

20 28. The system of claim 25, wherein the second endotracheal tube has a diameter smaller than the diameter of the main endotracheal tube.

29. The system of claim 25, wherein the connector further comprises a suction port adapted to connect to a fluid suction device and/or to facilitate administration of medical agents.

25 30. The system of claim 29, wherein the connector further comprises a valve, wherein when the valve is in a first position flow of sampled breath to the sampling line is allowed and the suction port is blocked and when the valve is in a second position

the suction port is opened and flow of sampled breath to the sampling line is blocked.

- 5 31. The system of claim 25, wherein the second endotrachial tube comprises at a distal end thereof two or more openings adapted to allow flow of breath to the second endotrachial tube.
32. The system of claim 25, wherein the sampling line comprises a drying tube adapted to absorb and/or pervaporate fluid present in the sampled breath.
33. The system of claim 25, wherein the double lumen endotrachial tube (ETT) is adapted for use with children, infants and/or neonates.
- 10 34. The system of claim 25, wherein the double lumen endotrachial tube (ETT) is adapted for use with subjects ventilated with High Frequency Ventilation (HFV).
- 15 35. The system of claim 34, wherein the one or more parameters related to concentration of carbon dioxide (CO₂) comprise Spontaneous End tidal CO₂ (S-EtCO₂), Spontaneous final inspired CO₂ (S-FiCO₂), Continuous CO₂ (Cont. CO₂), Diffusion CO₂ (DCO₂), density of Spontaneous breathing or any trend thereof or any combination thereof.
36. The system of claim 25, wherein the endotrachial tube (ETT) is an uncuffed endotrachial tube (ETT).
- 20 37. A connector adapted to connect a second endotrachial tube of a double lumen endotrachial tube (ETT) to a breath sampling line, the connector comprises:
- a connecting element adapted to connect to a second endotrachial tube of a double lumen endotrachial tube (ETT); and
- a sampling opening adapted to connect to a breath sampling line,

wherein the second endotracheal tube is adapted to sample breath for carbon dioxide (CO₂) concentration monitoring, from an area in the trachea located in proximity to a distal end of the endotracheal tube (ETT).

- 5 38. The connector of claim 37, further comprising a suction port adapted to connect to a fluid suction device and/or to facilitate administration of medical agents.
39. The connector of claim 38, further comprising a valve, wherein when the valve is in a first position flow of sampled breath to the sampling line is allowed and the suction port is blocked and when the valve is in a second position the suction port is allowed and flow of sampled breath to the sampling line is blocked.
- 10 40. The connector of claim 37, wherein the second endotracheal tube is located essentially inside the lumen of the main endotracheal tube, essentially inside the wall of the main endotracheal tube or partly in both.
41. The connector of claim 37, wherein the second endotracheal tube is located outside a main endotracheal tube of the double lumen endotracheal tube (ETT).
- 15 42. The connector of claim 37, wherein the second endotracheal tube has a diameter smaller than the diameter of a main endotracheal tube of the double lumen endotracheal tube (ETT).
43. The connector of claim 37, wherein the second endotracheal tube comprises at a distal end thereof two or more openings adapted to allow flow of the breath to the
20 second endotracheal tube.
44. The connector of claim 37, wherein the double lumen endotracheal tube (ETT) is adapted for use with children, infants and/or neonates.
45. The connector of claim 37, wherein the double lumen endotracheal tube (ETT) is adapted for use with subjects ventilated with High Frequency Ventilation (HFV).
- 25 46. The connector of claim 37, wherein the endotracheal tube (ETT) is an uncuffed endotracheal tube (ETT).

47. A method for evaluating carbon dioxide (CO₂) in breath of a subject ventilated with High Frequency Ventilation (HFV), the method comprising:
sampling breath from a distal area of a trachea of a subject; and
evaluating one or more CO₂ related parameters.
- 5 48. The method of clam 46, wherein sampling is conducted through an endotracheal tube (ETT).
49. The method of clam 46, wherein sampling is conducted through a second endotracheal tube of a double lumen endotracheal tube (ETT).
- 10 50. The method of clam 48, wherein the one or more CO₂ related parameters comprise Spontaneous End tidal CO₂ (S-EtCO₂), Spontaneous final inspired CO₂ (S-FiCO₂), Continuous CO₂ (Cont. CO₂), Diffusion CO₂ (DCO₂), density of spontaneous breathing or any trend thereof or any combination thereof.

1/7

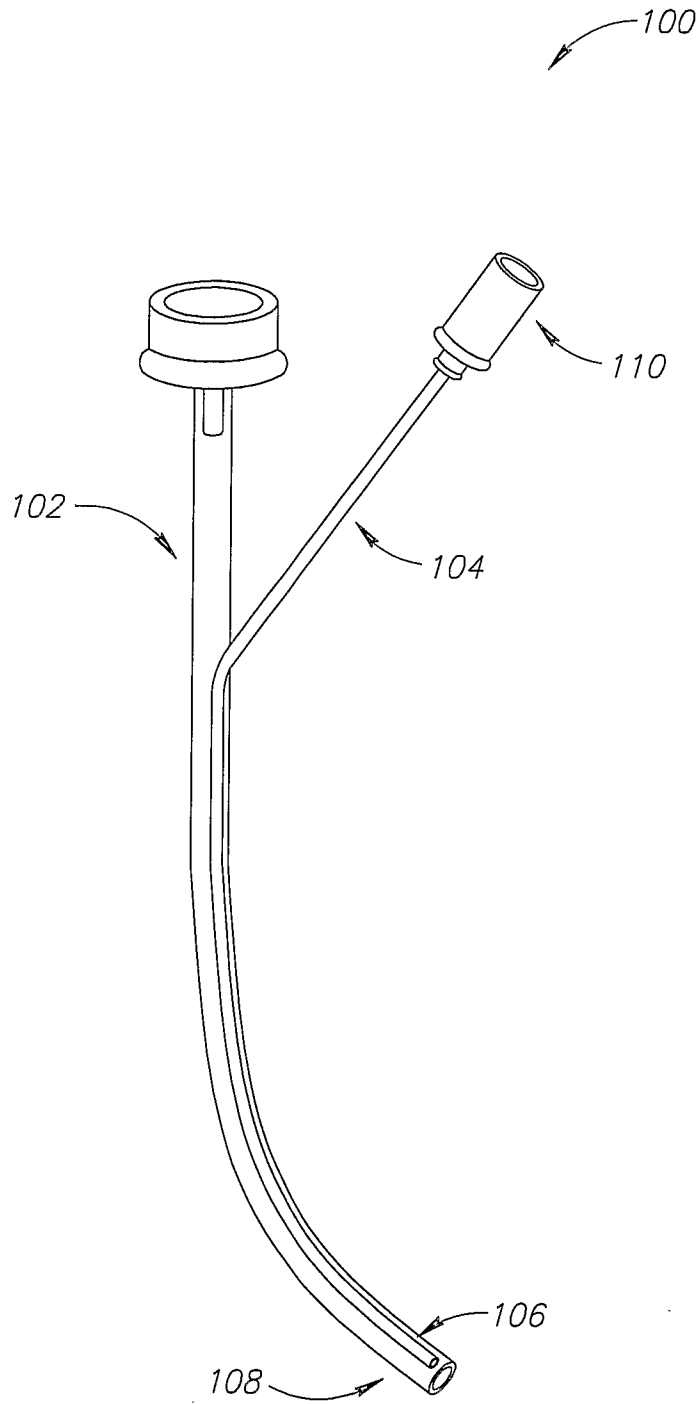

FIG.1A

2/7

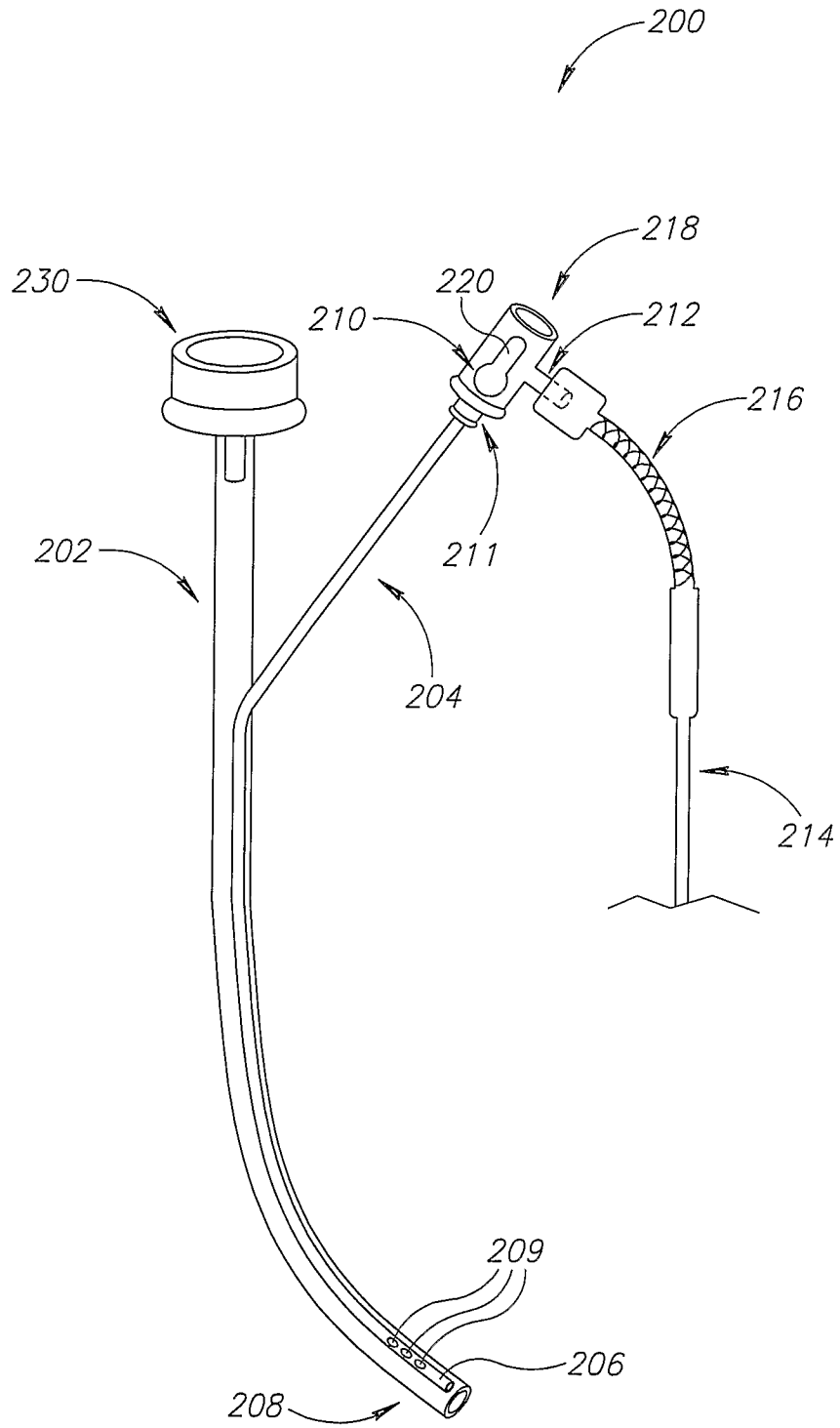

FIG.1B

3/7

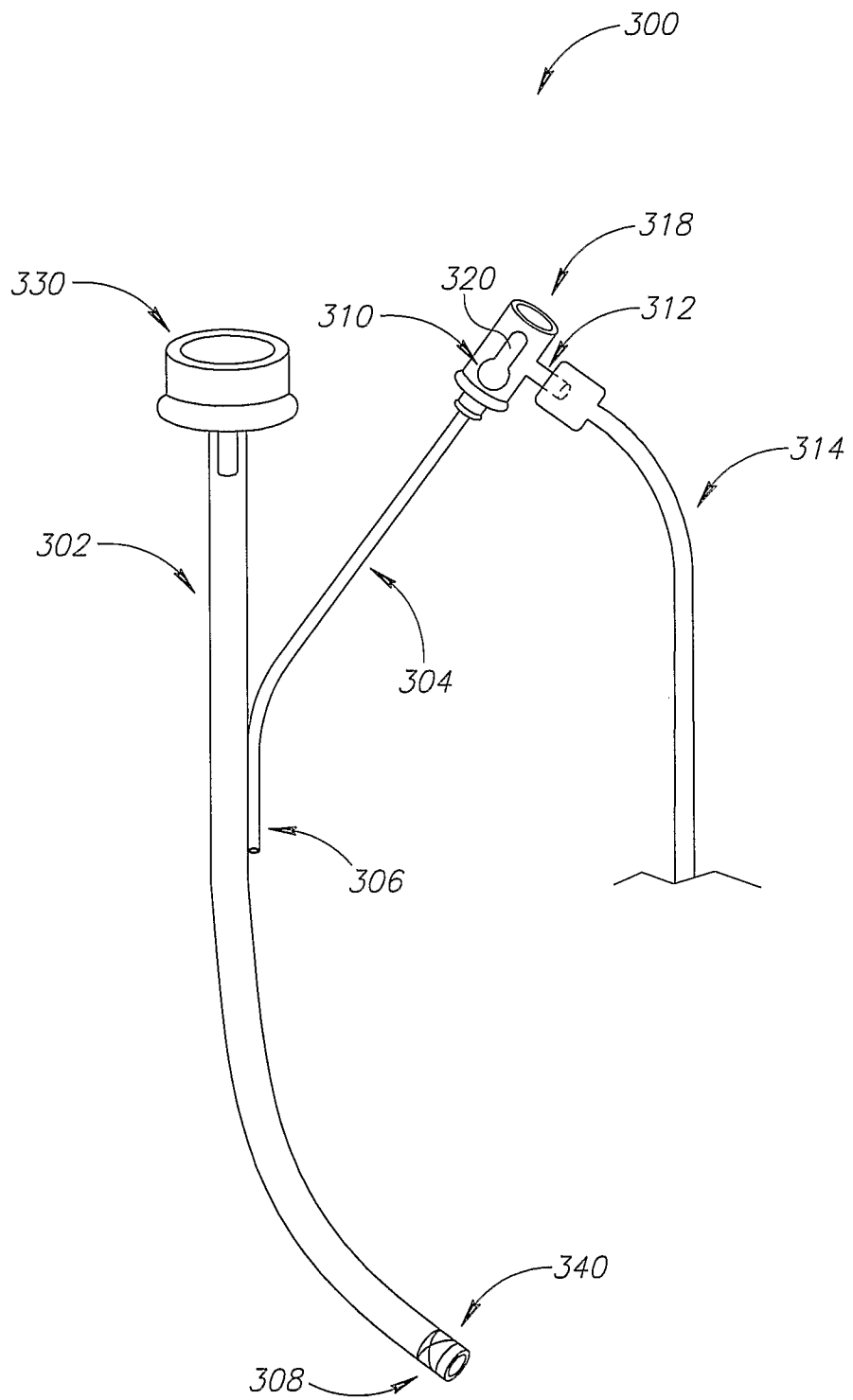

FIG.1C

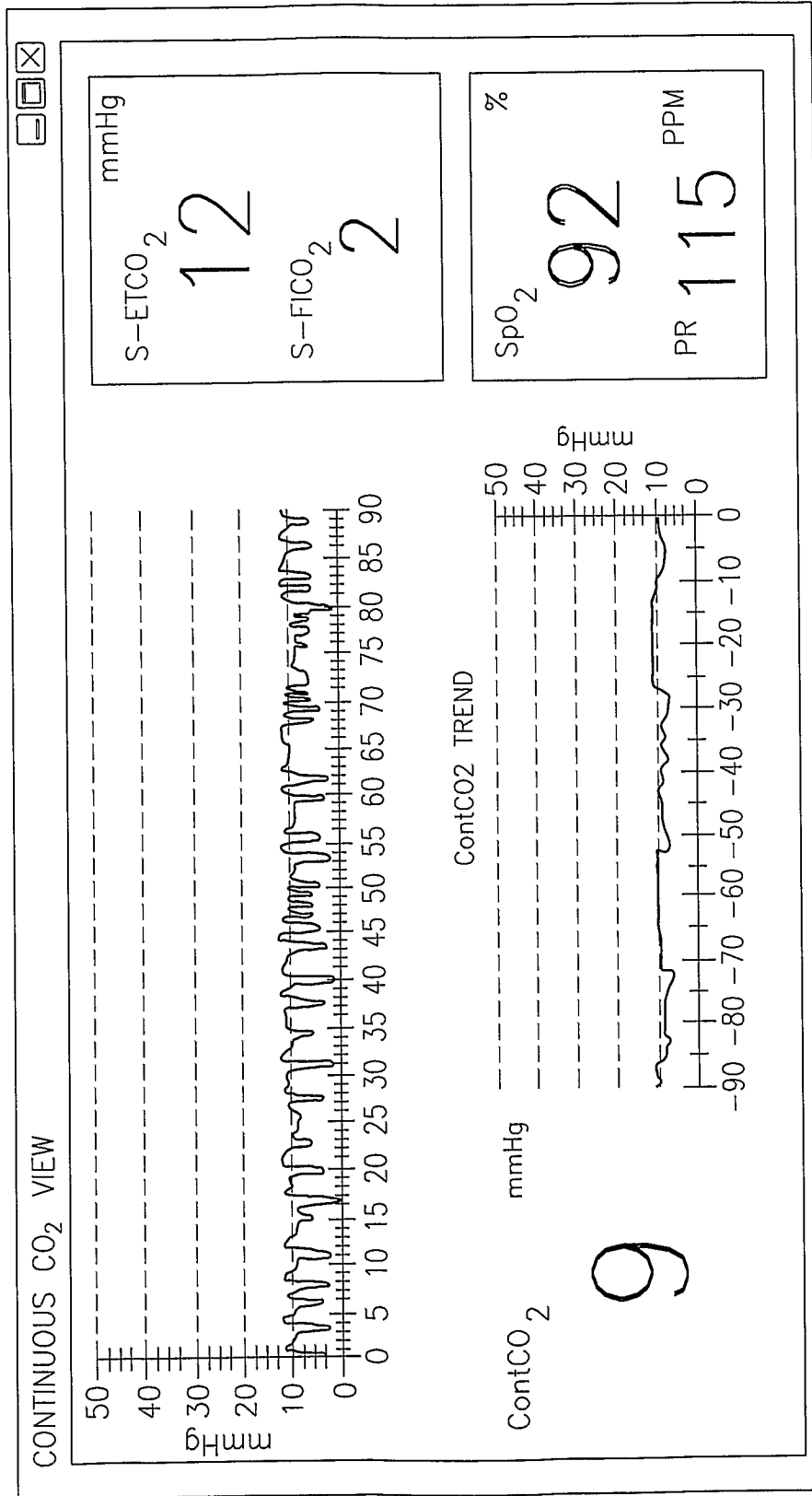

FIG.2

5/7

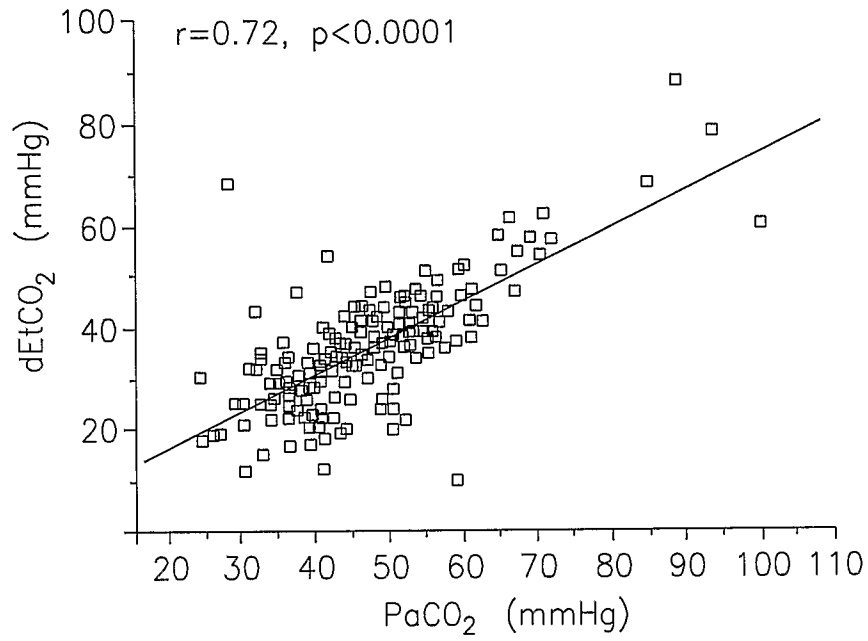

FIG.3A

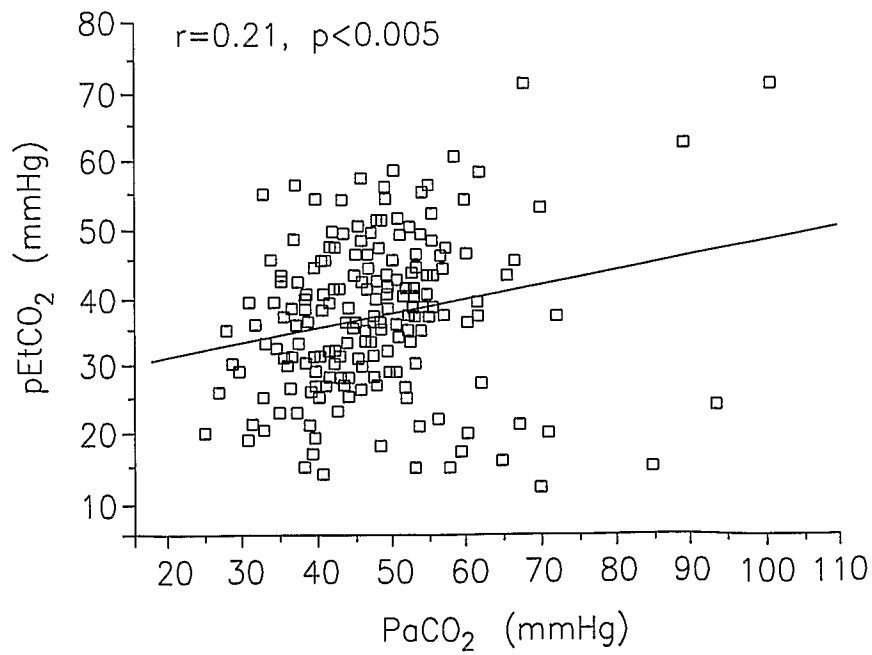

FIG.3B

6/7

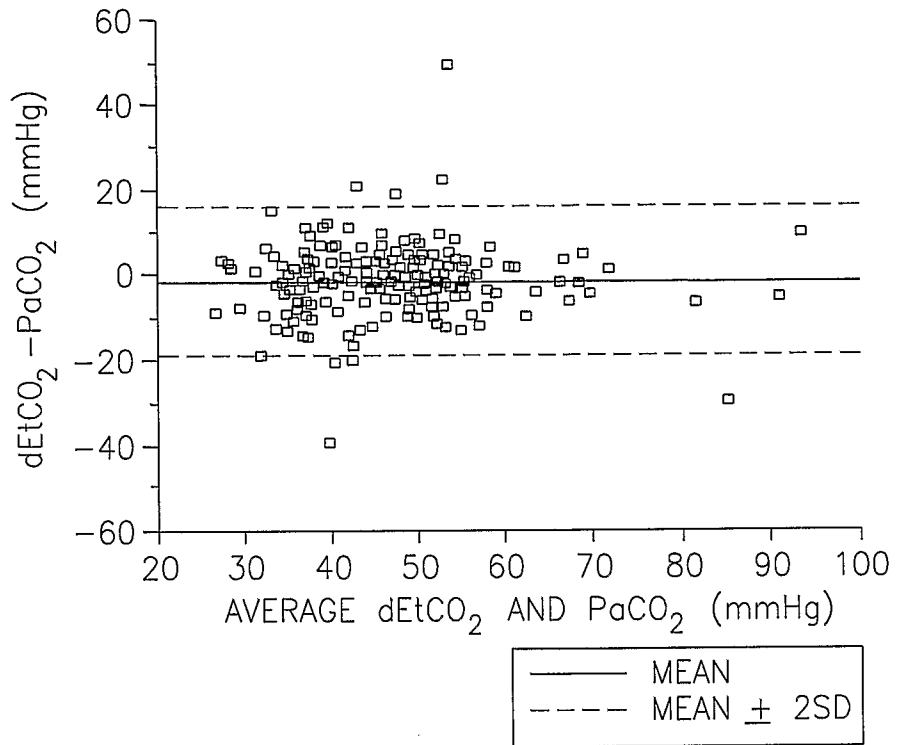

FIG.4A

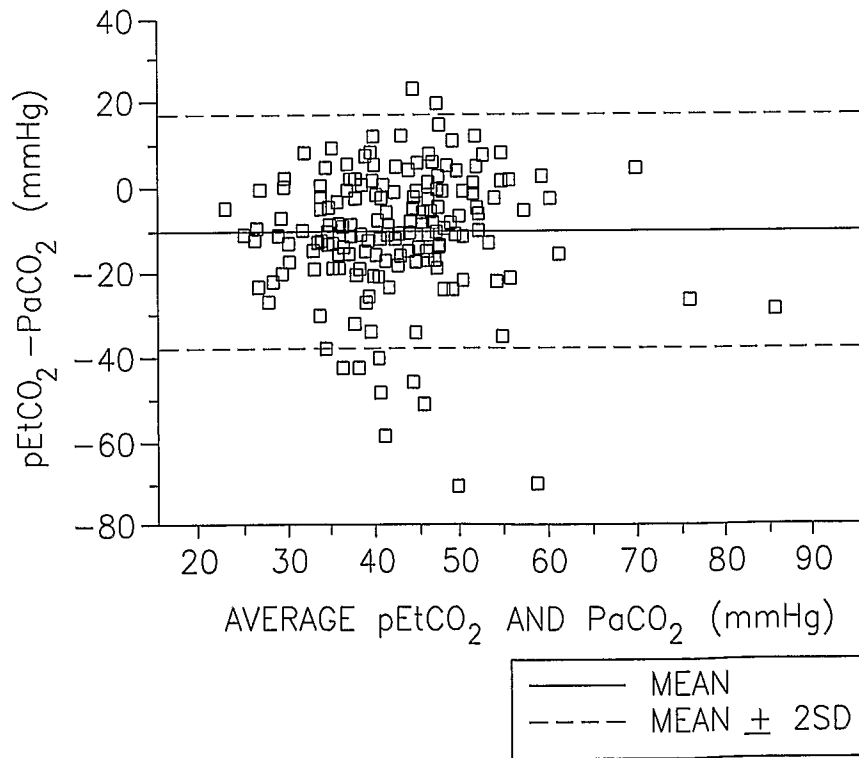

FIG.4B

7/7

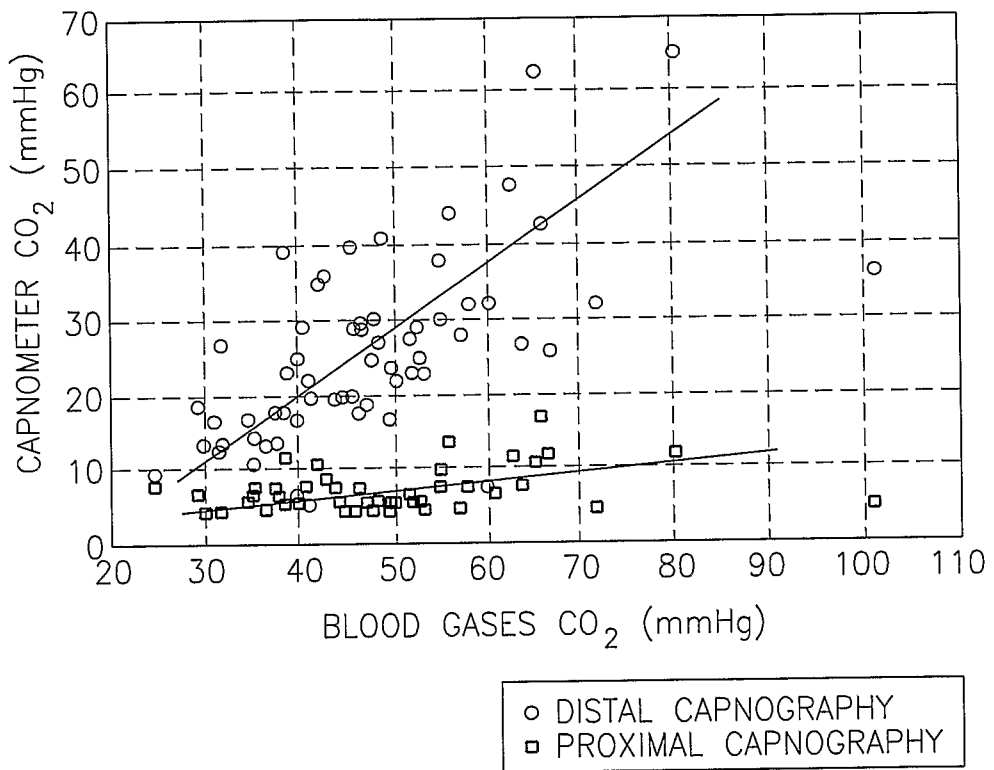

FIG.5

专利名称(译)	协同监控方法，装置和系统2		
公开(公告)号	EP2303376A2	公开(公告)日	2011-04-06
申请号	EP2009754350	申请日	2009-05-31
申请(专利权)人(译)	ORIDION MEDICAL 1987年LTD.		
当前申请(专利权)人(译)	ORIDION MEDICAL 1987年LTD.		
[标]发明人	COLMAN JOSHUA LEWIS SHALEV STEIN IRIS		
发明人	COLMAN, JOSHUA LEWIS SHALEV STEIN, IRIS		
IPC分类号	A61M16/04 A61M16/08 A61B5/0205 A61B5/00 A61B5/083 A61B5/097 A61M16/00 A61M16/10		
CPC分类号	A61B5/7282 A61B5/0205 A61B5/021 A61B5/024 A61B5/0402 A61B5/0476 A61B5/0816 A61B5/082 A61B5/0833 A61B5/0836 A61B5/087 A61B5/097 A61B5/7246 A61B5/7264 A61B5/742 A61B5/746 A61B10/00 A61B2010/0087 A61M5/1723 A61M16/0057 A61M16/0069 A61M16/0096 A61M16/04 A61M16/0463 A61M16/0484 A61M16/0486 A61M16/0488 A61M16/0816 A61M16/085 A61M16/20 A61M2016/0413 A61M2016/103 A61M2230/432 G06N5/04		
优先权	61/071959 2008-05-28 US		
其他公开文献	EP2303376B1		
外部链接	Espacenet		

摘要(译)

本文提供了用于评估受试者呼吸中的二氧化碳 (CO₂) 浓度的方法，装置和系统，例如在通过高频通气 (HFV) 通气的受试者中，该方法包括向受试者的气管插入气管内导管 (ETT)，从位于气管内管 (ETT) 远端附近的气管区域取样呼吸，并评估采样呼吸的一个或多个CO₂相关参数。