

(19)



(11)

EP 2 931 116 B1

(12)

EUROPEAN PATENT SPECIFICATION

(45) Date of publication and mention of the grant of the patent:
06.03.2019 Bulletin 2019/10

(51) Int Cl.:
A61B 5/00 (2006.01) A61M 25/00 (2006.01)
A61B 5/0215 (2006.01) A61B 5/01 (2006.01)

(21) Application number: **13818866.9**

(86) International application number:
PCT/US2013/073968

(22) Date of filing: **10.12.2013**

(87) International publication number:
WO 2014/093263 (19.06.2014 Gazette 2014/25)

(54) SHEATH WITH OPTICALLY INTERROGATABLE SENSORS

HÜLLE MIT OPTISCH ABFRAGBAREN SENSOREN

GAINÉ COMPRENANT DES SONDÉS INTERROGEABLES PAR VOIE OPTIQUE

(84) Designated Contracting States:
AL AT BE BG CH CY CZ DE DK EE ES FI FR GB GR HR HU IE IS IT LI LT LU LV MC MK MT NL NO PL PT RO RS SE SI SK SM TR

(74) Representative: **de Haan, Poul Erik et al**
Philips International B.V.
Philips Intellectual Property & Standards
High Tech Campus 5
5656 AE Eindhoven (NL)

(30) Priority: **12.12.2012 US 201213712368**

(56) References cited:
WO-A1-90/01294 WO-A1-2011/034491
WO-A2-2011/091408 US-A- 4 691 708
US-A- 4 730 622 US-A- 6 030 371
US-A1- 2004 263 857 US-A1- 2012 162 662
US-A1- 2012 220 883

(43) Date of publication of application:
21.10.2015 Bulletin 2015/43

(73) Proprietor: **Volcano Corporation**
San Diego, CA 92130 (US)

(72) Inventor: **FLANDERS, Dale C.**
Lexington, Massachusetts 02420 (US)

EP 2 931 116 B1

Note: Within nine months of the publication of the mention of the grant of the European patent in the European Patent Bulletin, any person may give notice to the European Patent Office of opposition to that patent, in accordance with the Implementing Regulations. Notice of opposition shall not be deemed to have been filed until the opposition fee has been paid. (Art. 99(1) European Patent Convention).

Description

BACKGROUND OF THE INVENTION

[0001] Heart disease is a leading cause of death for men and women in the United States. Consequently, there are numerous medications, medical procedures, and medical devices for diagnosing and treating heart disease.

[0002] One type of medical procedure aimed at diagnosing heart disease is angiography. The procedure requires injecting a contrast agent into the blood stream and then taking x-ray images to determine if there is a blockage within the blood vessel.

[0003] A problem with an angiography is that the procedure can only determine if a blockage exists, but not whether the blockage is actually affecting the blood flow within the blood vessel. As a result, many patients elect to have unnecessary procedures to treat the blockage without confirming the severity of the blockage.

[0004] Another procedure for assessing heart disease is fractional flow reserve (FFR). FFR is a technique used in coronary catheterization to measure the pressure difference and thus blood flow across a partially blocked or constricted artery. Using a guidewire system, measurements are taken on both sides of a blockage within a blood vessel to determine if there is a pressure gradient or reduced blood flow due to the blockage. If there is no drop in pressure (or a nominal drop), then there may be no need for further medical intervention because the blockage is not significantly impeding the flow of blood. Conversely, if there is a significant drop across the blockage, then the blockage may need to be removed or treated because the blood flow is impaired by the blockage.

[0005] Generally, the FFR procedure is performed by inserting a guidewire system into the femoral or radial artery of the patient. The guidewire is maneuvered into position within a partially blocked blood vessel, and a sensor at the distal end of the guidewire is used to measure pressure, temperature, and/or blood flow to determine the severity of the blockage. The sensor is connected to a display device such as a monitor of a computer screen to display the patient's readings during the procedure.

[0006] Swept source catheters are also useful for assessing heart disease. For example, with OCT catheters, a section of a patient's vessel is scanned to accumulate linear or two dimensional image data which are used to build up a volumetric image of the blood vessel. One specific application involves the scanning of arteries, such as coronary arteries. The OCT catheter is inserted into an artery segment of interest typically using a guidewire system. The OCT catheter is then rotated and drawn back through the artery to produce a helical scan of the inner vessel wall. In a similar technology, a swept source catheter is used to determine the spectral response and thus the chemical constituents of the vessels walls, but typically not volumetric vessel images.

[0007] US 2004/0263857 A1 discloses in Fig. 5 a medical device 500 that has an external tube 552 enclosing an internal tube 554, which is attached to the inner wall of the external tube. External tube 552 has two openings 556 a-b, each sized and shaped to accommodate a corresponding pressure sensor 504a/504b, while internal tube 554 accommodates an optical fiber 502 having thin-film filters 508a-b. Each sensor 504 is inserted into the corresponding opening 556 and attached to fiber 502 such that the corresponding filter 508 is aligned with the sensor. After the sensor insertion, openings 556 a-b are sealed such that sensors 504a-b remain exposed on the exterior of external tube 552. When device 500 is inserted into a blood vessel (e.g., an aorta), sensors 504a-b can be used to monitor blood pressure at their respective locations.

SUMMARY OF THE INVENTION

[0008] The invention is defined by the claims.

[0009] The present invention concerns the use of an array of pressure sensors to detect pressure within an intravascular system. One embodiment of this invention includes an intravascular pressure sensor system interrogating the array of pressure sensors with a swept source catheter. In this embodiment, the swept source is able to acquire both image and pressure data of a patient's vessel or artery for example. In addition, the system is able to acquire a pressure profile along the length of an artery/vessel.

[0010] In general, according to one aspect, the invention features an intravascular sensor system in accordance with claim 1.

[0011] A method of detecting an intravascular pressure is presented described. This method includes inserting an intravascular sheath embedded with pressure sensors into a vessel of a patient. Then, inserting a swept source catheter into the sheath. Then, the vessel is scanned with a swept source optical signal from the swept source catheter. The swept source catheter is drawn through the sheath. Then, the pressure sensors are scanned with the swept source optical signal. The pressures are determined based on optical responses of the pressure sensors to the swept source optical signal.

[0012] A method of calibrating a pressure sensor array system is presented as example. This method includes placing a pressure sensor array system with embedded pressure sensors in a pressure vessel. Then, the pressure vessel is set to a first pressure. Then, the pressure sensors are optically interrogated. Then, the pressure vessel is set to a next pressure. The pressure sensors are optically interrogated again. This method results in the generation of a calibration table of wavelength changes as a function of pressure change for each of the pressure sensors.

[0013] The above and other features of the invention including various novel details of construction and combinations of parts, and other advantages, will now be

more particularly described with reference to the accompanying drawings and pointed out in the claims.

[0014] It will be understood that the particular method and device embodying the invention are shown by way of illustration and not as a limitation.

BRIEF DESCRIPTION OF THE DRAWINGS

[0015] In the accompanying drawings, reference characters refer to the same or similar parts throughout the different views. The drawings are not necessarily to scale; emphasis has instead been placed upon illustrating the principles of the invention. Of the drawings:

FIG. 1 is a cross-sectional view of an intravascular pressure sensor system in the lumen of a patient according to an embodiment of the invention.

FIG. 2 is a detailed view of the swept source catheter from FIG. 1 in a sheath of the pressure sensor system.

Fig. 3 is a schematic view of the human circulatory system with the sheath extending from the femoral artery to the coronary artery of a patient's heart according to an embodiment of the invention.

Fig. 4 is a cross-sectional view of the pressure sensor according to an embodiment of the invention.

Fig. 5A is top view of a membrane from the pressure sensor according to an embodiment of the invention.

Fig. 5B is a top view of a membrane from the pressure sensor according to another embodiment of the invention.

Fig. 6A is a schematic cross-sectional view of a pressure sensor in which the ambient pressure is equal to the pressure within the port.

Fig. 6B is a plot of reflectivity as a function of wavelength (arbitrary units) for the pressure sensor illustrated in Fig. 6A.

Fig. 6C is schematic cross-sectional view of the pressure sensor when the ambient pressure is greater than the pressure within the port.

Fig. 6D is a plot of reflectivity as a function of wavelength (arbitrary units) for the pressure sensor illustrated in Fig. 6C.

Fig. 7 is a schematic view of a swept source system according to an embodiment of the invention.

Figs. 8A-8B are cross-sectional views of the intravascular pressure sensor system in operation show-

ing the movement of the swept source catheter through the sheath.

Fig. 9 is a flowchart illustrating a process of manufacturing pressure sensors in a sheath according to an embodiment of the invention.

Fig. 10 is a flowchart illustrating a calibration of pressure sensors based on pressure measurements according to an embodiment of the invention.

Fig. 11 is a flowchart illustrating a method of using pressure sensors with a swept source catheter according to an embodiment of the invention.

Fig. 12 is a cross-sectional view of the temperature sensor according to an embodiment of the invention.

DETAILED DESCRIPTION OF THE PREFERRED EMBODIMENTS

[0016] Figs. 1 and 2 illustrate an intravascular sensor system 100 to which the present invention is applicable.

[0017] The intravascular sensor system 100 is shown within a lumen 10 of a human body. In one example, the lumen 10 is a blood vessel, such as a coronary or carotid artery.

[0018] The intravascular sensor system 100 includes a catheter 50, such as a swept source catheter. The swept source catheter 50 includes a probe 105 located at the end of the catheter 50. The probe 105 emits and receives an optical beam B in a direction that is lateral to the probe 105.

[0019] The swept source catheter 50 also includes an optical fiber 52 extending longitudinally in the catheter 50. This optical fiber 52 transmits beam B to and from the probe 105.

[0020] The intravascular sensor system 100 includes a sheath 20. The sheath 20 is inserted into the lumen/vessel 10 of a body. The swept source catheter 50 is inserted and guided into the sheath 20. In one example, the sheath 20 is tubular, optically transmissive, and functions to protect the lumen/vessel 10 from catheter movement.

[0021] The sheath 20 has a wall 30 embedded with an array of sensors 110 along the length of the sheath 20. In one embodiment, the sensors 110 are pressure sensors. In other examples, the sensors 110 are temperature sensors. In still other embodiments, the sensors 110 are a combination of pressure sensors and temperature sensors.

[0022] In a preferred embodiment, the sensors 110 include pressure sensors. These pressure sensors 110 are used to detect the pressure in multiple locations along the length of the lumen/vessel 10. In use, the beam B from the swept source catheter 50 scans and optically interrogates the pressure sensors 110. The swept source catheter 50 is able to spectral response data from these pressure sensors 110 during scanning.

[0023] The sheath 20 includes an imaging region 40 where the swept source catheter 50 collects image data from the lumen/vessel 10. This imaging region 40 of the sheath 20 is free from embedded pressure sensors 110, in a currently preferred embodiment.

[0024] In more detail, the sheath 20 is inserted into the lumen/vessel 10. The swept source catheter 50 is introduced within the sheath 20. The beam B is emitted and collected through an optical port 120 of the probe 105. In the example of an OCT probe, the beam B is used to analyze the refractive index profile (A-scan) in the illuminated region 12 of the lumen/vessel 10. The beam B is also used to optically interrogate the pressure sensors 110 embedded along the sheath 20. A complete scan of the inner wall of the lumen/vessel 10 is collected by helically scanning the probe 105 along a segment of the lumen/vessel 10 marked as the imaging region 40.

[0025] Fig. 2 illustrates a more detailed view of the intravascular pressure sensor system 100 in operation. The beam B is transmitted through the optical port 120 of the swept source catheter 50 and then through the sheath wall 30, see reference 58. The beam B scans the lumen/vessel 10 as well as the pressure sensors 110. This is typically achieved by simultaneously rotating the probe 105, see arrow 54, while simultaneously withdrawing the probe 105 through the segment of interest, see arrow 56. The sheath 20 protects the lumen/vessel 10 during these scanning operations.

[0026] As described above, the sheath wall 30 is embedded with pressure sensors 110. The sheath wall 30 includes an inner wall section 30A and an outer wall section 30B. In this example, these wall sections 30A, 30B are formed with layers of polymer. The pressure sensors 110 are embedded particularly within the outer wall section 30B in this example.

[0027] Fig. 2 also illustrates the interaction of the blood flow BF with the embedded pressure sensors 110. The flowing blood BF has a blood pressure BP that can vary at different positions along the length of the lumen/vessel 10. The varied blood pressures BP are sensed by the pressure sensors 110 along the length of the sheath 20. As the blood flow BF passes by the pressure sensors, it exerts a blood pressure BP that is detected mechanically by the pressure sensor.

[0028] Fig. 3 shows the sheath 20 embedded with pressure sensors 110 within the human circulatory system. The sheath 20 extends to the coronary artery 300 inside the heart 320, according to one application. The sheath 20 is initially inserted into the femoral artery 310 in the leg of a patient. From the femoral artery 310, the sheath 20 is extended to the thoracic aorta 330. The sheath 20 is directed from the thoracic aorta 330 along the aortic arch 340 to the coronary artery 300 in the heart 320. In one example, the sheath has a length of about 1.5 meters, long enough to stretch from the femoral artery 310 to the coronary artery 300. In alternative embodiments, the sheath 20 is inserted via the radial or other artery, or vein. In other applications, other arteries or

veins are the vessels of interest.

[0029] Fig. 4 shows a detailed view of the pressure sensor 110.

[0030] The pressure sensor 110 includes a substrate 400 that is the base of the sensor 110. In this example, the substrate 400 has a hollow cylindrical shape with a diameter of preferably less than 1 millimeter (mm) and a thickness of less than 0.5 mm. A port 410 extends through the center of the substrate 400. In one example, the substrate 400 is made from a wafer material such as a silicon wafer.

[0031] The pressure sensor 110 further includes a set of membranes 420 or diaphragms. A first membrane 420 is attached or fabricated on the substrate 400 so that it extends over one end of the port 410. A second membrane 420 is attached or fabricated to an opposite side of the substrate 400 extending over the other end of the port 410. The membrane 420 can be made from silicon nitride or silicon wafer material, for example.

[0032] The pressure sensor 110 is manufactured with an internal manufacturing pressure in the port 410. This manufacturing pressure is typically equal to the manufacturing ambient pressure, for example. The manufacturing ambient pressure is usually based on the conditions within a tool used to manufacture the sensors 110. More particularly, the internal manufacturing pressure is based on the temperature and quantity of gas sealed within the port 410 of the pressure sensor 110.

[0033] As described above, these pressure sensors 110 can be used within the human body. In one example, the sensors 110 are manufactured to take into account the human body temperature and pressure. The temperature within the human body is about 37 degrees Celsius. Therefore, this temperature along with the pressure of the blood can cause the membranes 420 to flex inwards if they are manufactured at room temperature and pressure. In one embodiment, the pressure sensors 110 are manufactured at higher temperature or pressure. When the pressure sensors are inserted into a patient, the membranes 420 flex to a neutral or flat position.

[0034] Figs. 5A-5B show two different types of membranes 420 extending over the port 410 of the substrate 400.

[0035] In Fig. 5A, the membrane 420 has a mirror coating 500 that covers the entire membrane 420. Alternatively, in Fig. 5B, the membrane 420 has a mirror coating 500 that covers only a center portion of the membrane 420.

[0036] Fig. 6A illustrates the mechanical response of the pressure sensor 110 when the ambient pressure is about equal to the internal manufacturing pressure within the port 410 of the sensor 110. Since these pressures are equal, the membranes 420 do not flex but maintain a level surface over the port 410. A distance D1 between the first membrane 420 and second membrane 420 can be determined and is associated with this particular ambient pressure.

[0037] Fig. 6B is a plot of reflectivity as a function of

wavelength for the pressure sensor 110 in Fig. 6A. The membranes 420 function as an etalon or Fabry-Perot filter. When the swept source catheter 50 optically interrogates and scans the sensor 110, it acquires reflectivity (%) of the membranes 420 over a range of wavelengths (λ). Alternatively, the reflectivity is measured by another spectroscopy system including a broadband source and a spectrally resolved detector. The membranes 420 have a minimum reflectivity and maximum transmissivity at wavelength λ_1 . This minimum reflectivity is based on the distance between the two membranes 420. Thus, distance D1 correlates with wavelength λ_1 .

[0038] Fig. 6C illustrates the mechanical response of the pressure sensor 110 when the ambient pressure is greater than the internal manufacturing pressure within the port 410 of the sensor 110. At this pressure difference, the membranes 420 flex inwards into the port 410. A distance D2 between the first membrane 420 and second membrane 420 can be determined and is associated with this particular ambient pressure.

[0039] Fig. 6D is a plot of reflectivity as a function of wavelength for the pressure sensor 110 in Fig. 6C. In this example, the membranes 420 have a minimum reflectivity and maximum transmissivity at wavelength λ_2 from data acquired by the swept source catheter 50. This minimum reflectivity is based on the distance D2 between the flexed membranes 420. Thus, distance D2 correlates with wavelength λ_2 .

[0040] When comparing the plots in Figs. 6B and 6D, the reflection minimum wavelength λ_2 for the increased pressure shifted to the longer wavelengths compared with the equalized pressure reflection minimum wavelength λ_1 . This shift is used to determine associated pressure being applied.

[0041] Fig. 7 shows one example of the components within a swept source catheter 50. In this example, the swept source catheter 50 is an optical coherence analysis system.

[0042] This embodiment includes the capability of performing spectroscopic and OCT analysis on a sample 5 such as the wall of the lumen/vessel 10. This embodiment also includes the capability of optically interrogating pressure sensors 110.

[0043] An optical swept source system 700 generates a tunable or swept optical signal on optical fiber 710 that is transmitted to interferometer 800. The swept optical signal scans over a scan band with a narrowband emission.

[0044] The swept source system 700 is generally intended for high speed tuning to generate swept optical signals that repeatedly scan over the scan band(s) at rates of greater than 1 kilohertz (kHz). In current embodiments, the multi-sweep rate swept source system 700 tunes at speeds greater than 20 or 100 kHz. In very high speed embodiments, the multi-sweep rate swept source system 700 tunes at speeds greater than 200 or 500 kHz.

[0045] Typically, the width of the tuning or scan band is greater than 10 nanometers (nm). In the current em-

bodiments, it is preferably between 50 and 150 nm, although even wider tuning bands are contemplated in some examples. On the other hand, the bandwidth of the narrowband emission has a full width half maximum (FWHM) bandwidth of less than 20 or 10 GigaHertz (GHz), and is usually 5 GHz or less. For optical coherence tomography, this high spectral resolution implies a long coherence length and therefore enables imaging deeper into samples, for example deeper than 5 millimeters (mm). On the other hand, in lower performance applications, for example OCT imaging less than 1 mm deep into samples, broader FWHM passbands are sometimes appropriate, such as passbands of about 200 GHz or less.

[0046] In one example, the swept source system 700 includes a tunable laser for generating the swept optical signals. The advantages of tunable lasers include high spectral brightness and relatively simple optical designs. A tunable laser is constructed from a gain medium, such as a semiconductor optical amplifier (SOA) that is located within a resonant cavity, and a tunable element such as a rotating grating, grating with a rotating mirror, or a Fabry-Perot tunable filter. Currently, some of the highest tuning speed/sweep rate lasers are based on the laser designs described in U.S. Pat. No. 7,415,049 B1, entitled Laser with Tilted Multi Spatial Mode Resonator Tuning Element, by D. Flanders, M. Kuznetsov and W. Atia. The use of micro-electro-mechanical system (MEMS) Fabry-Perot tunable filters combines the capability for wide spectral scan bands with the low mass, high mechanical resonant frequency deflectable MEMS membranes that have the capacity for high speed tuning/sweep rates. Another laser architecture is termed a Fourier-domain mode-locked laser (FDML). This type of laser stores light in a long length of fiber for amplification and recirculation in synchronism with the laser's tuning element. See "Fourier Domain Mode Locking (FDML): A new laser operating regime and applications for optical coherence tomography", R. Huber, M. Wojtkowski, and J. G. Fujimoto, 17 April 2006 / Vol. 14, No. 8 / OPTICS EXPRESS 3225. The drawback of these devices is their complexity, however. Moreover, the ring cavity including the long storage fiber creates its own performance problems such as dispersion and instability.

[0047] Another class of swept sources that has the potential to avoid inherent drawbacks of tunable lasers is filtered amplified spontaneous emission (ASE) sources that combine a broadband light source, typically a source that generates light by ASE, with tunable filters and amplifiers. Some of the highest speed devices based on filtered ASE sources are described in U.S. Pat. No. 7,061,618 B2, entitled Integrated Spectroscopy System, by W. Atia, D. Flanders P. Kotidis, and M. Kuznetsov. A number of variants of the filtered ASE swept source are described, including amplified versions and versions with tracking filters. Still other configurations of the filtered ASE sources are described in U.S. Pat. Appl. Serial No. 12/553,295, filed on September 3, 2009, entitled Filtered

ASE Swept Source for OCT Medical Imaging, by D. Flinders, W. Atia, and M. Kuznetsov (U.S. Pat. Pub. No. US 2011/0051148 A1), which is incorporated herein in its entirety by this reference. This lays out various integrated, high speed filtered ASE swept source configurations. U.S. Patent Appl. Serial No. 12/776,373, filed on May 8, 2010, entitled ASE Swept Source with Self-Tracking Filter for OCT Medical Imaging, by the same inventors (U.S. Pat. Pub. No. US 2011/0051143 A1), outlines still further configurations that rely on the use of a self-tracking filter arrangement that can improve performance both in terms of sweep rate and linewidth, among other things, and which is also incorporated herein in its entirety by this reference.

[0048] A controller 790 generates a drive waveform that is supplied to a digital to analog converter 772 (DAC). This generates a tunable element drive signal 708 that is amplified by amplifier 774 and applied to the swept source system 700. In one example, the controller 790 stores a filter drive waveform that linearizes the frequency sweep for one or more tunable optical filters, such as Fabry-Perot tunable filters or other tunable optical elements, contained in the swept source system 700.

[0049] In the example, a Mach-Zehnder-type interferometer 800 is used to analyze the optical signals from the sample 5. The swept optical signal from the swept source system 700 is transmitted on fiber 710 to a 90/10 optical fiber coupler 810 or other beam splitter, to give specific examples. The swept optical signal is divided between a reference arm 820 and a sample arm 812 of the system.

[0050] The optical fiber 830 of the reference arm 820 terminates at the fiber endface 824. The light 702R exiting from the reference arm fiber endface 824 is collimated by a lens 826 and then reflected by a mirror 828 to return back, in some exemplary implementations.

[0051] The external mirror 828 has an adjustable fiber to mirror distance, in one example. This distance determines the depth range being imaged, i.e. the position in the sample 5 of the zero path length difference between the reference arm 820 and the sample arm 812. The distance is adjusted for different sampling probes and/or imaged samples. Light 702R returning from the reference mirror 828 is returned to a reference arm circulator 822 and directed to a 50/50 fiber coupler 840. In other examples, such as those using free space optical configurations, the coupler 840 is often replaced with a partially reflecting mirror/beam splitter.

[0052] The fiber 52 on the sample arm 812 terminates at the sample arm probe 105. The exiting swept optical signal 702S is focused by the probe 105 onto the sample 5. Light returning from the sample 5 is returned to a sample arm circulator 814 and directed to the fiber coupler 840.

[0053] The reference arm signal and the sample arm signal are combined or mixed in the fiber coupler 840 or other beam combiner to generate an interference signal.

[0054] The interference signal is detected by a detec-

tion system 750. Specifically, a balanced receiver, comprising two detectors 752, is located at each of the outputs of the fiber coupler 840 in the illustrated embodiment. The electronic interference signal from the balanced receiver 752 is amplified by amplifier 754.

[0055] Once a complete data set has been collected of the sample 5 by spatially raster scanning the focused probe beam point over the sample, in a Cartesian geometry, x-y, fashion or a cylindrical geometry theta-z fashion, and the spectral response at each one of these points is generated from the frequency tuning of the optical swept source system 700, the data acquisition and processing system 755 performs a Fourier transform on the data in order to reconstruct the image and perform a 2D or 3D tomographic reconstruction of the sample 5. This information is displayed by the display system 780.

[0056] In one application, the probe 105 is inserted into blood vessels and used to scan the inner wall of arteries and veins. In other examples, other analysis modalities are included in the probe such as intravascular ultrasound (IVUS), forward looking IVUS (FLIVUS), high-intensity focused ultrasound (HIFU), pressure sensing wires and image guided therapeutic devices. In still other applications, the probe is used to scan different portions of an eye or tooth or other structure of a patient or animal. Such diagnostic imaging can also be used for image guided therapy and combined with therapeutic modalities, such as laser surgery.

[0057] The probe 105 is also used to determine the spectral response of the pressure sensors 110 during scanning and specifically determine the reflectivity minimums described in Figs. 6B and 6D. In operation, the probe 105 scans the pressure sensors 110 while sweeping across a range of wavelengths. During this scanning and sweeping, the light returning from each pressure sensor 110 is returned to the sample arm circulator 814 and directed to the fiber coupler 840. From the fiber coupler 840, the signal is detected by the detection system 750 as described above.

[0058] The controller 790 monitors the response of the detectors 752. Based on this detection, the controller 790 determines the wavelength having the minimum reflectivity or maximum transmissivity. The controller 790 associates this minimum reflectivity with a specific pressure value. Thus, the pressure profile along the length of the sheath 20 can be determined based on the acquired spectral response, having the lowest reflectivity, for each pressure sensor.

[0059] The optical coherence analysis system of the swept source catheter 50 also includes an ambient pressure detector 760. The ambient pressure detector 760 measures the current ambient pressure for a location where the swept source catheter 50 is being used. For example, the ambient pressure is the pressure within a doctor's office or hospital room. This measured ambient pressure is inputted into the detection system 750 where it is directed to the controller 790. The controller 790 uses this detected ambient pressure as a base line for deter-

mining the pressure at each pressure sensor 110.

[0060] It should be noted that in the preferred embodiment, the spectral response is obtained by spectrally scanning the narrowband emission of the swept source 700 and then resolving the spectral response from the response of the detectors 752, over the period of the sweep. In an alternative configuration, the swept source 700 is replaced with a broadband source that emits a broadband signal that covers the scanband. The detectors 752 are then replaced with spectrally resolving detector systems. An example of such a detector system is described in U.S. Pat. No. 6,665,458. Another example uses a grating to spatially disperse the spectrum along with a linear detector array.

[0061] Figs. 8A-8B show the movement of the swept source catheter 50 through the sheath 20 embedded with pressure sensors 110. As shown, the swept source catheter 50 scans the vessel 10 and pressure sensors 110 while being withdrawn from the sheath 20. The swept source catheter 50 is rotated during this scanning/withdrawing process.

[0062] Fig. 9 illustrates the process of manufacturing a sheath 20 embedded with pressure sensors 110.

[0063] This process includes a step 900 of providing a mandrel such as a core mandrel. Then, step 902 includes spraying on powder base coats of polymer onto the mandrel. In another example, a liner is placed over the mandrel before step 902.

[0064] The mandrel can be grounded and the powder charged as the unmelted powders are applied, thereby causing powders to electrostatically cling to the heated mandrel or liner during application. When this base polymer is sprayed onto the heated mandrel or liner, the powder melts to form a uniform coating over the surface.

[0065] The spraying technique is accomplished with spray heads that traverse the mandrel while the mandrel is being rotated. These spray heads apply atomized sprays of powder that fuse to the surface of the mandrel. Each spray head is connected to multiple containers of polymer materials and preferably an opacifier material, such as tungsten.

[0066] The coats of polymer are further baked in step 904. Baking occurs in an oven to consolidate the material within these base coats of polymer. More importantly, the baking ensures complete fusion of the sprayed polymer to the mandrel. The baking or heating can be accomplished with infrared, hot air, or resistance heating of the mandrel core.

[0067] Next, pressure sensors 110 are embedded over the length of the sheath 20 on the base coats in step 908. Step 910 includes spraying on planarizing coats of powder polymer over the pressure sensors 110. These planarizing coats are baked in step 912.

[0068] In step 914, final coats of polymer powder are sprayed over the pressure sensors 110. These final coats are baked in step 916.

[0069] In step 918, a sheath 20, embedded with pressure sensors 110, is removed from the mandrel.

[0070] Fig. 10 illustrates the process of calibrating pressure sensors 110 based on pressure measurements according to one example.

[0071] Initially in step 920, the embedded sheath 20 is placed within a pressure vessel. Next, in step 922, the vessel is set to a first pressure (P_1). Preferably the temperature is set to that of the human body.

[0072] In step 924, each of the pressure sensors 110 are optically interrogated with a swept source or broadband source with a spectrally resolving detector. The controller 790 in combination with the detection system 750 measures the spectral response for each pressure sensor 110 in step 926.

[0073] In step 928, steps 924 and 926 are repeated until all the measured pressures have been applied. Step 930 sets the vessel to a next pressure (P_n) as part of the repeating step 928.

[0074] In step 932, a calibration table is generated including wavelength changes ($\Delta\lambda_n$) corresponding with equivalent pressure changes (ΔP_n). This calibration table is used by the controller 790 to determine the intravascular pressure along the lumen/vessel 10 during an operation in the patient.

[0075] Fig. 11 is a method of using pressure sensors with a swept source catheter.

[0076] Initially in step 940, a guidewire is inserted into the lumen/vessel 10 of a patient. In step 942, the embedded sheath 20 is inserted into the lumen/vessel 10 using the guide wire. Then, in step 944, the swept source catheter 50 is inserted into the sheath 20.

[0077] In step 946, the swept source catheter 50 is directed to a specific imaging region 40 in the sheath 20. The swept source catheter 50 scans the lumen/vessel 10 at the imaging region 40 to develop a volumetric and/or spectral image in step 948. Then, the swept source catheter 50 is drawn back through the sheath 20 while scanning the pressure sensors 110 in step 950.

[0078] In step 952, the controller 790 within the swept source catheter 50 determines the wavelength of the reflectivity minima for each pressure sensor 110. Then, in step 954, the controller 790 determines a pressure at each pressure sensor 110 based on the calibration table, from step 932, and the detected wavelength minima, from step 952.

[0079] In step 956, the controller 790 develops a pressure profile along the lumen/vessel 10 based on the pressure sensors 110. It should also be appreciated that the pressure profile is also calibrated across temperature. As result, when multiple pressure sensors 110 are exposed to the same pressure then differences between those pressure sensors will be indicative of a temperature at the location of those sensors. In this way, the pressure sensors can also function as temperature sensors especially in the situation where the pressure sensors are located with a relatively high density along the length of the sheath 20.

[0080] Fig. 12 illustrates still another embodiment of the sensor 110. In this example, the sensor 110 simply

includes a single membrane 420. In one example, this membrane 420 is constructed from a thermochromic material or composite material. In other examples, the thermochromic material is applied to the substrate. Such materials change color in response to temperature. In one example, the thermochromic composite material is liquid crystal material. When these thermochromic sensors 110 are embedded in the sheath 20, and then scanned by the catheter 50, the temperature along the length of the sheath 20 is resolved to detect hotspots, for example, in the coronary arteries, for example.

[0081] While this invention has been particularly shown and described with references to preferred embodiments thereof, it will be understood by those skilled in the art that various changes in form and details may be made therein without departing from the scope of the invention encompassed by the appended claims.

Claims

1. An intravascular sensor system (100), comprising:
 - a sheath (20) configured to be inserted into a vessel (10) of a patient;
 - a sensor array comprising a plurality of optically interrogable sensors (110) embedded within a wall (30) of the sheath; **characterised in that** the system further comprises
 - a catheter (50) configured to be inserted within the sheath along a length of the sensor array, the catheter configured to be drawn back through the sheath so as to optically interrogate the sensors.
2. The intravascular sensor system of claim 1, wherein the sensor array includes pressure sensors that each comprises:
 - a substrate (400) having a central port (410);
 - a first membrane (420) extending over one end of the central port; and
 - a second membrane (420) extending over the other end of the central port.
3. The intravascular sensor system of claim 2, wherein the substrate is fabricated from wafer material.
4. The intravascular sensor system of claim 2 or claim 3, wherein each membrane includes a mirror coating (500) on at least one face of the membrane.
5. The intravascular sensor system of claim 4, wherein the mirror coating completely covers the membrane.
6. The intravascular sensor system of any preceding claim, wherein the sensor array comprises temperature sensors.

7. The intravascular sensor system of any preceding claim, wherein the catheter includes a catheter body with an optical fiber for transmitting an optical beam (B) for optically interrogating the sensor array.
8. The intravascular sensor system of any preceding claim, wherein the sheath includes an imaging region (40) that is free from embedded sensors to allow the catheter to collect image data from the vessel of the patient.
9. The intravascular sensor system of any of claims 1 to 8, wherein the catheter is a swept source catheter.
10. The intravascular sensor system of any of claims 1 to 8, wherein the catheter comprises an optical coherence tomography (OCT) probe.

Patentansprüche

1. Intravaskuläres Sensorsystem (100), umfassend:
 - eine Scheide (20), die konfiguriert ist, in ein Gefäß (10) eines Patienten eingesetzt zu werden;
 - eine Sensoranordnung, umfassend eine Vielzahl von optisch absuchbaren Sensoren (110), die innerhalb einer Wand (30) der Scheide eingebettet ist;
 - dadurch gekennzeichnet, dass** das System weiter
 - einen Katheter (50) umfasst, der konfiguriert ist, um innerhalb der Scheide entlang einer Länge der Sensoranordnung eingesetzt zu werden, wobei der Katheter konfiguriert ist, um durch die Scheide zurückgezogen zu werden, um die Sensoren optisch abzusuchen.
2. Intravaskuläres Sensorsystem nach Anspruch 1, wobei die Sensoranordnung Drucksensoren beinhaltet, die jeweils Folgendes umfassen:
 - ein Substrat (400), das eine zentrale Öffnung (410) aufweist;
 - eine erste Membran (420), die sich über ein Ende der zentralen Öffnung erstreckt; und
 - eine zweite Membran (420), die sich über das andere Ende der zentralen Öffnung erstreckt.
3. Intravaskuläres Sensorsystem nach Anspruch 2, wobei das Substrat aus Wafer-Material gefertigt ist.
4. Intravaskuläres Sensorsystem nach Anspruch 2 oder Anspruch 3, wobei jede Membran eine Spiegelbeschichtung (500) an wenigstens einer Stirnfläche der Membran beinhaltet.
5. Intravaskuläres Sensorsystem nach Anspruch 4,

wobei die Spiegelbeschichtung die Membran vollständig bedeckt.

6. Intravaskuläres Sensorsystem nach einem der vorstehenden Ansprüche, wobei die Sensoranordnung Temperatursensoren umfasst.
7. Intravaskuläres Sensorsystem nach einem der vorstehenden Ansprüche, wobei der Katheter einen Katheterkörper mit einer Glasfaser zum Übertragen eines optischen Lichtstrahls (B) zum optischen Absuchen der Sensoranordnung beinhaltet.
8. Intravaskuläres Sensorsystem nach einem der vorstehenden Ansprüche, wobei die Scheide eine Bildregion (40) beinhaltet, die frei von eingebetteten Sensoren ist, um es dem Katheter zu erlauben, Bild-daten von dem Gefäß des Patienten zu sammeln.
9. Intravaskuläres Sensorsystem nach einem der Ansprüche 1 bis 8, wobei der Katheter ein Swept-Source-Katheter ist.
10. Intravaskuläres Sensorsystem nach einem der Ansprüche 1 bis 8, wobei der Katheter eine optische Kohärenz-Tomographie-Sonde (OCT) ist.

Revendications

1. Système de capteur intravasculaire (100), comprenant :

une gaine (20) configurée pour être insérée dans un vaisseau (10) d'un patient ;
 un groupement de capteurs comprenant une pluralité de capteurs pouvant être interrogés de façon optique (110) incorporés à l'intérieur d'une paroi (30) de la gaine ; **caractérisé en ce que** le système comprend en outre
 un cathéter (50) configuré pour être inséré à l'intérieur de la gaine le long d'une longueur du groupement de capteurs, le cathéter étant configuré pour être retiré à travers la gaine afin d'interroger les capteurs de façon optique.

2. Système de capteur intravasculaire selon la revendication 1, dans lequel le groupement de capteurs inclut des capteurs de pression qui comprennent chacun :

un substrat (400) ayant un orifice central (410) ;
 une première membrane (420) s'étendant au-dessus d'une extrémité particulière de l'orifice central ; et
 une seconde membrane (420) s'étendant au-dessus de l'autre extrémité de l'orifice central.

3. Système de capteur intravasculaire selon la revendication 2, dans lequel le substrat est fabriqué à partir d'une matière de plaquette.

4. Système de capteur intravasculaire selon la revendication 2 ou la revendication 3, dans lequel chaque membrane inclut un revêtement miroir (500) sur au moins une face particulière de la membrane.

5. Système de capteur intravasculaire selon la revendication 4, dans lequel le revêtement miroir couvre complètement la membrane.

6. Système de capteur intravasculaire selon n'importe quelle revendication précédente, dans lequel le groupement de capteurs comprend des capteurs de température.

7. Système de capteur intravasculaire selon n'importe quelle revendication précédente, dans lequel le cathéter inclut un corps de cathéter avec une fibre optique pour transmettre un faisceau optique (B) pour interroger le groupement de capteurs de façon optique.

8. Système de capteur intravasculaire selon n'importe quelle revendication précédente, dans lequel la gaine inclut une région d'imagerie (40) qui est exempte de capteurs incorporés pour permettre au cathéter de collecter des données d'image provenant du vaisseau du patient.

9. Système de capteur intravasculaire selon l'une quelconque des revendications 1 à 8, dans lequel le cathéter est un cathéter à source balayée.

10. Système de capteur intravasculaire selon l'une quelconque des revendications 1 à 8, dans lequel le cathéter comprend une sonde tomographie à cohérence optique (OCT).

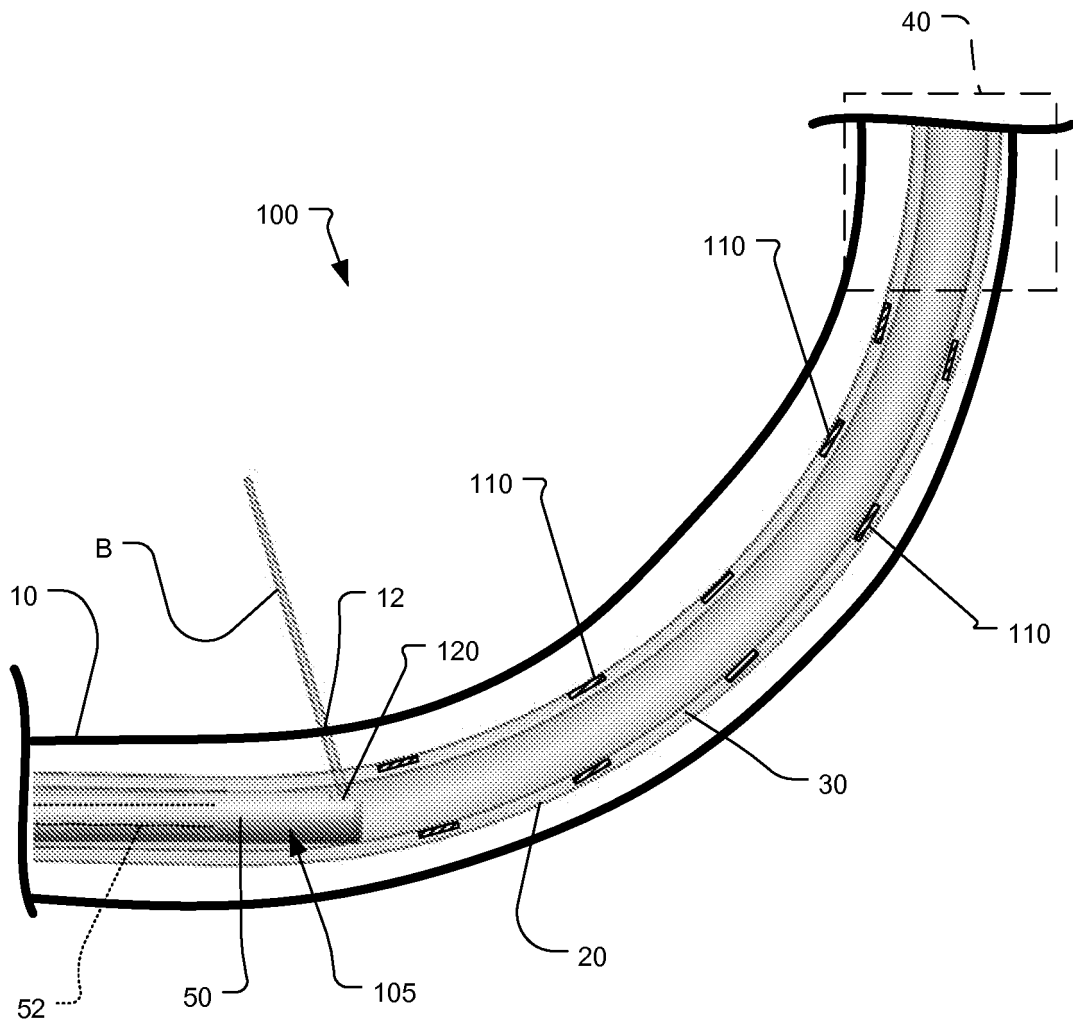


Fig. 1

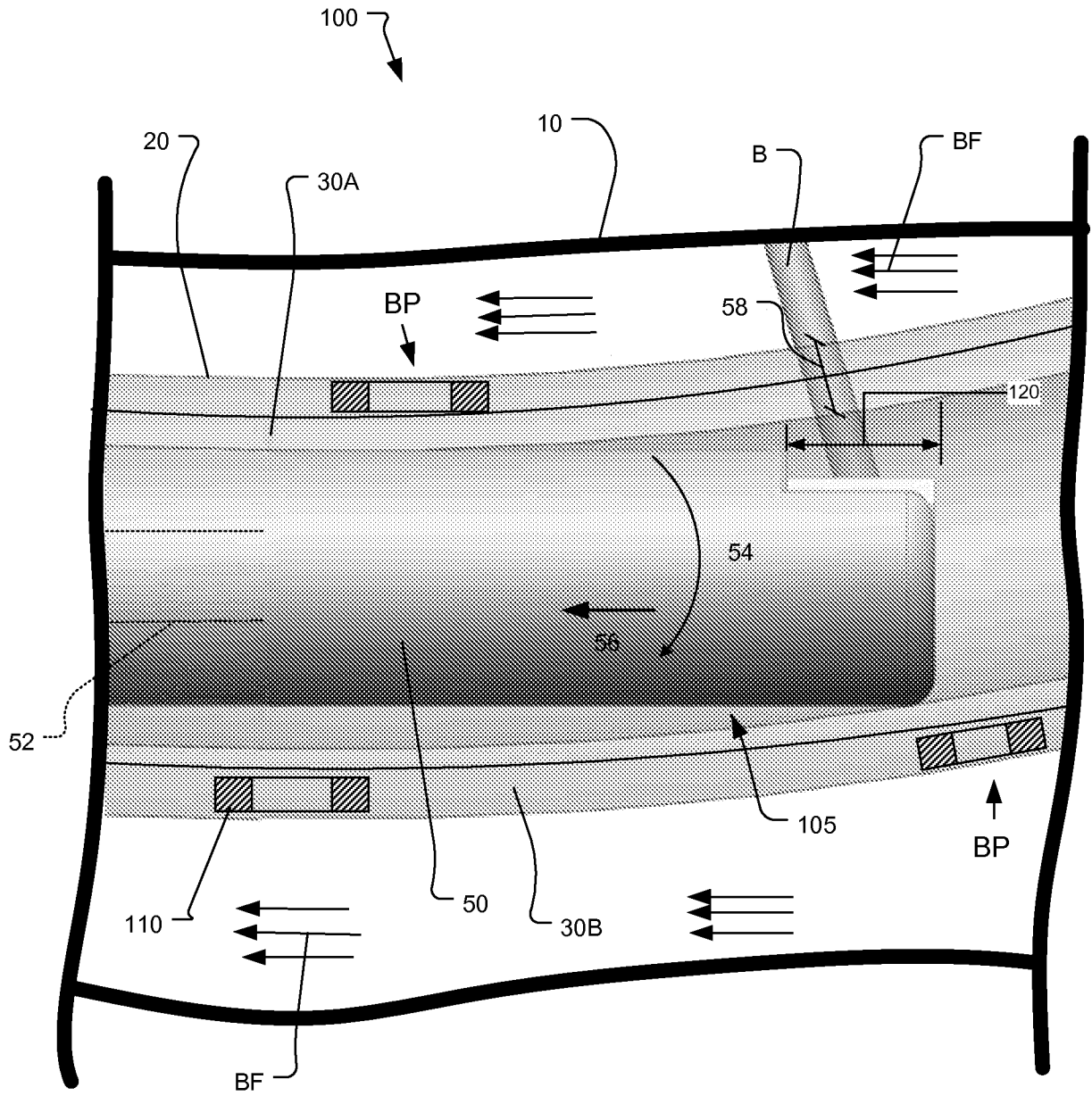


Fig. 2

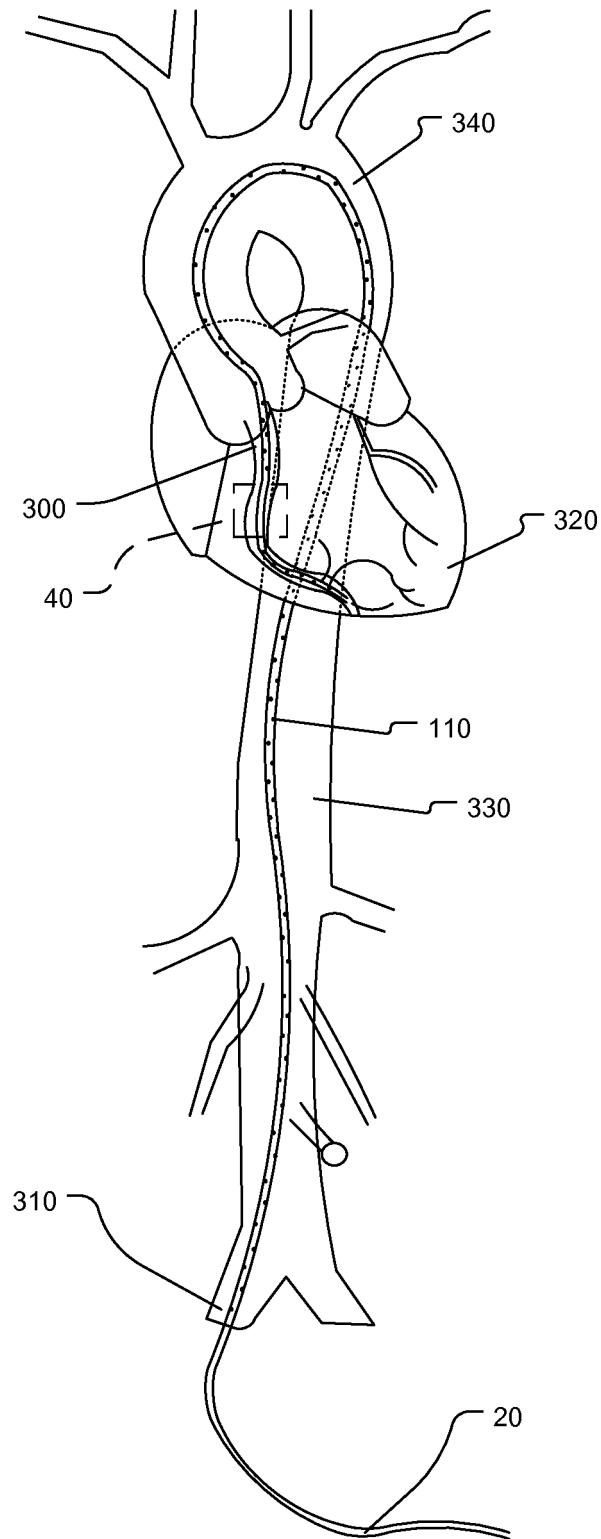


Fig. 3

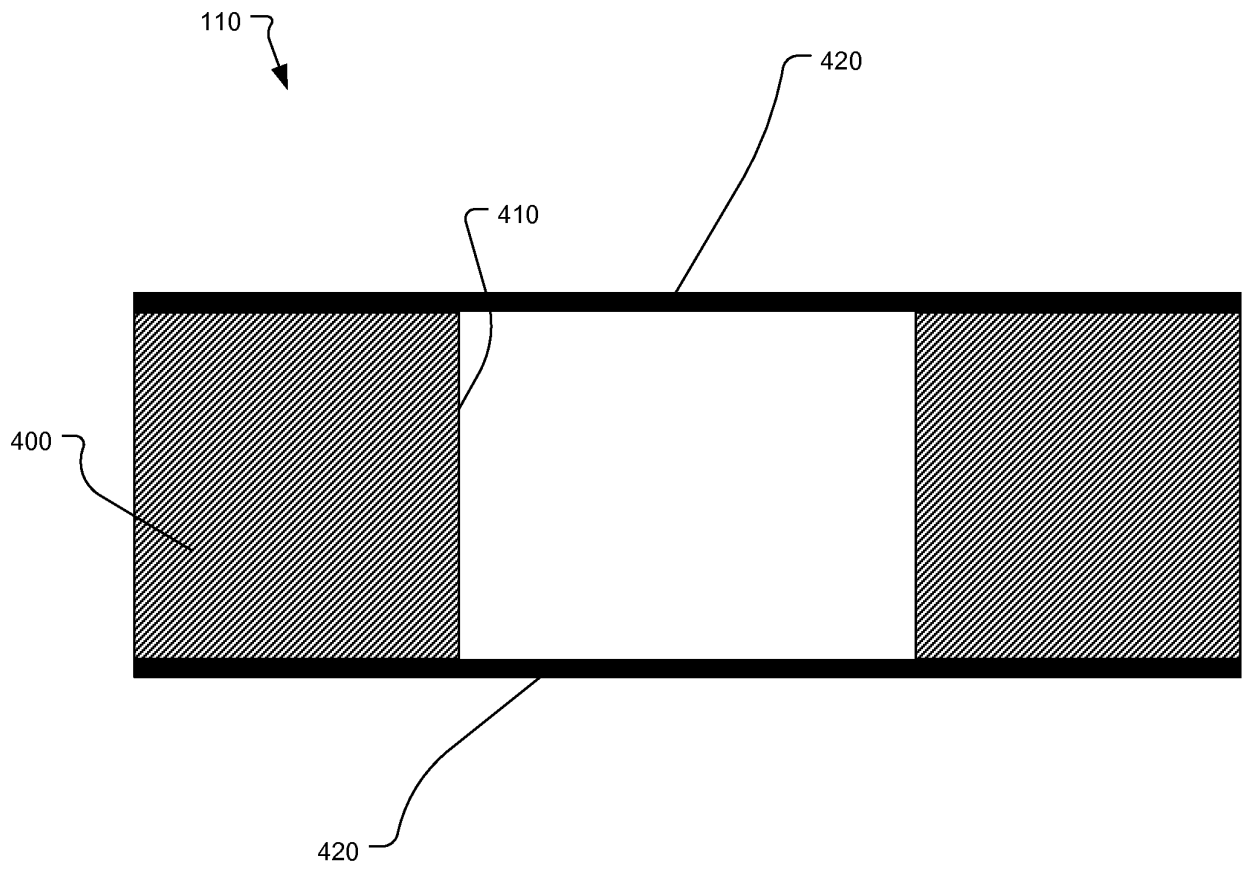


Fig. 4

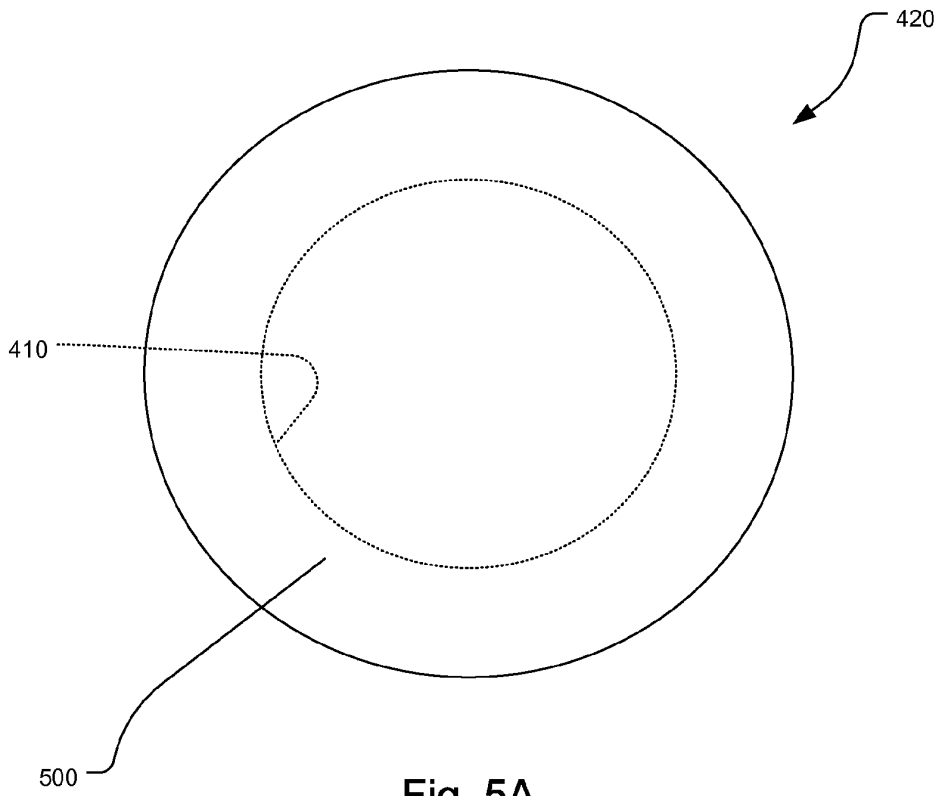


Fig. 5A

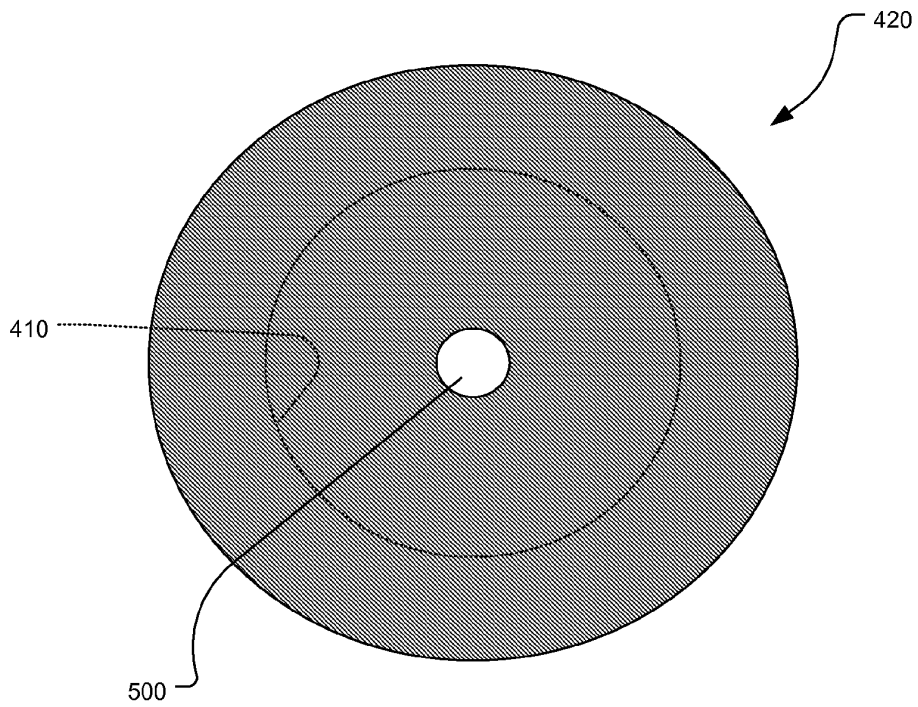


Fig. 5B

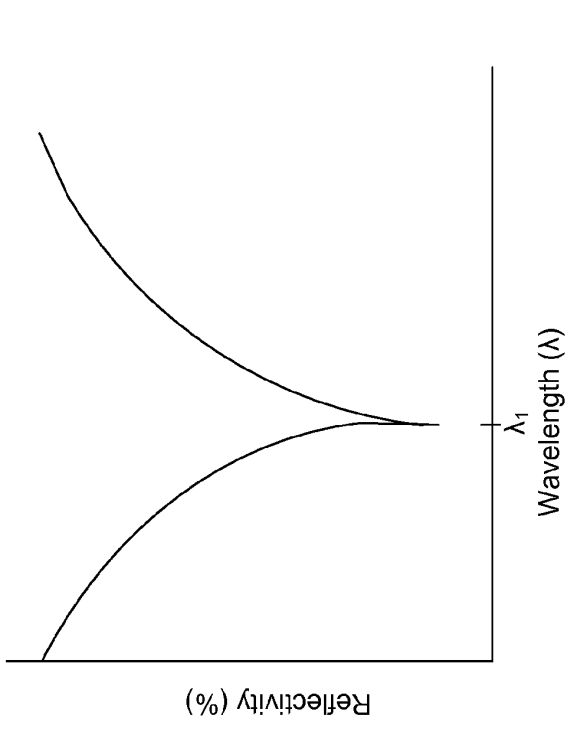


Fig. 6B

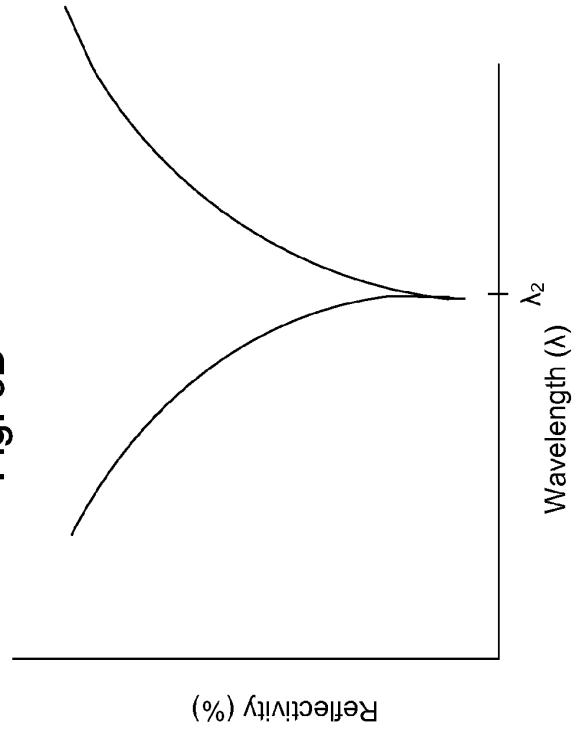


Fig. 6D

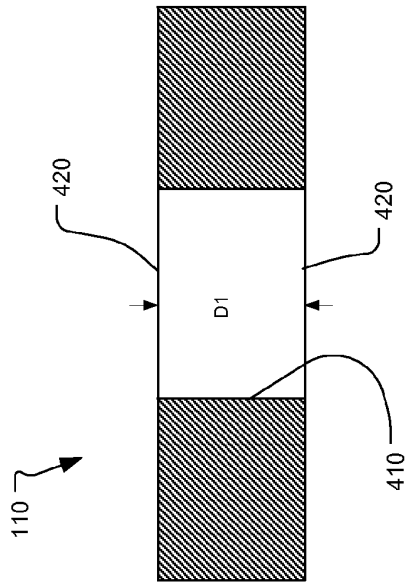


Fig. 6A

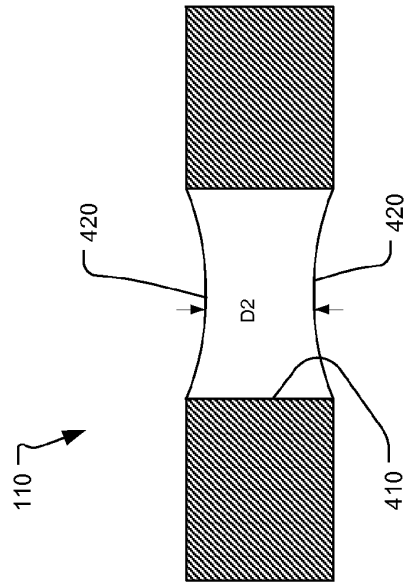


Fig. 6C

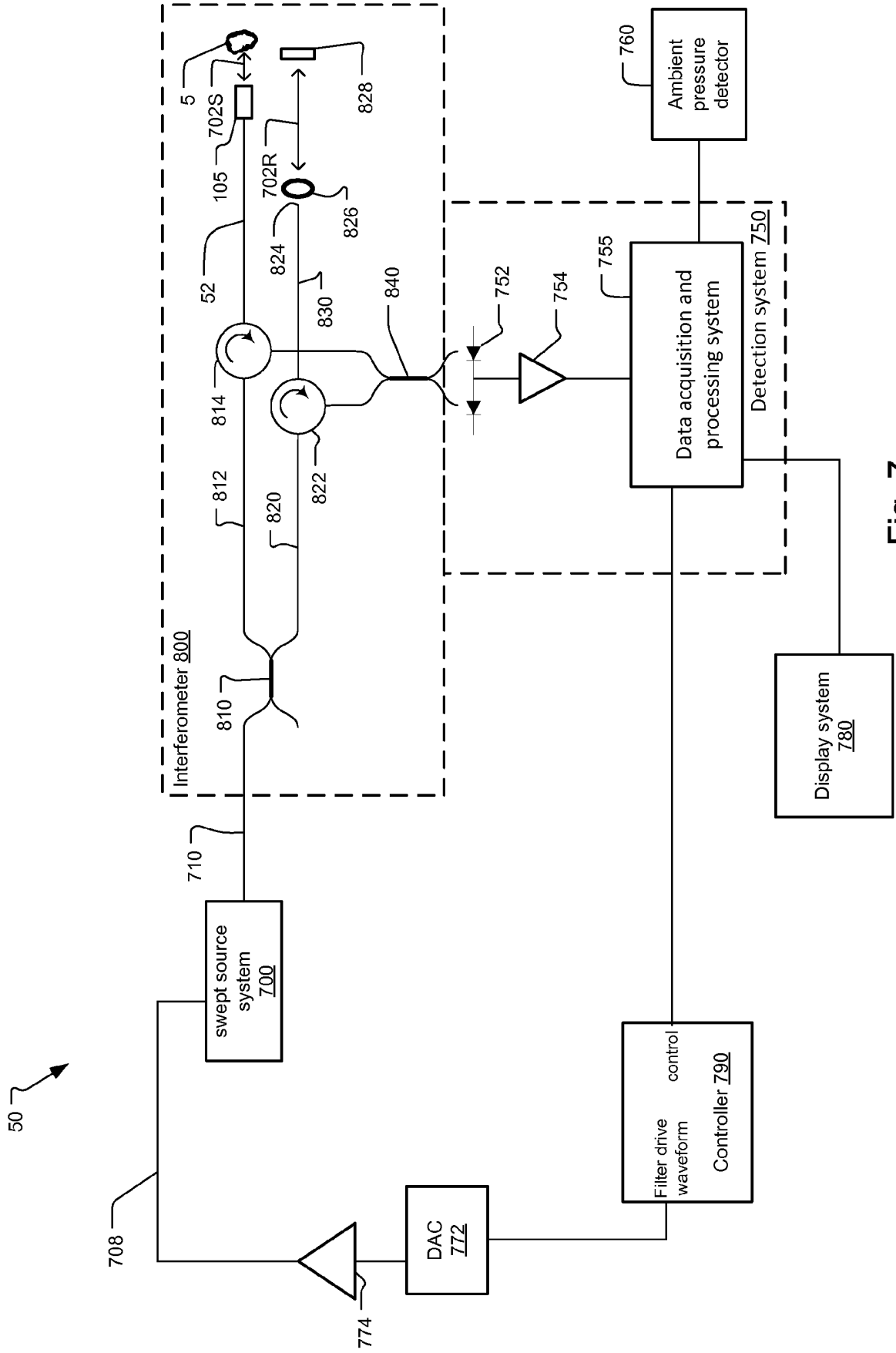


Fig. 7

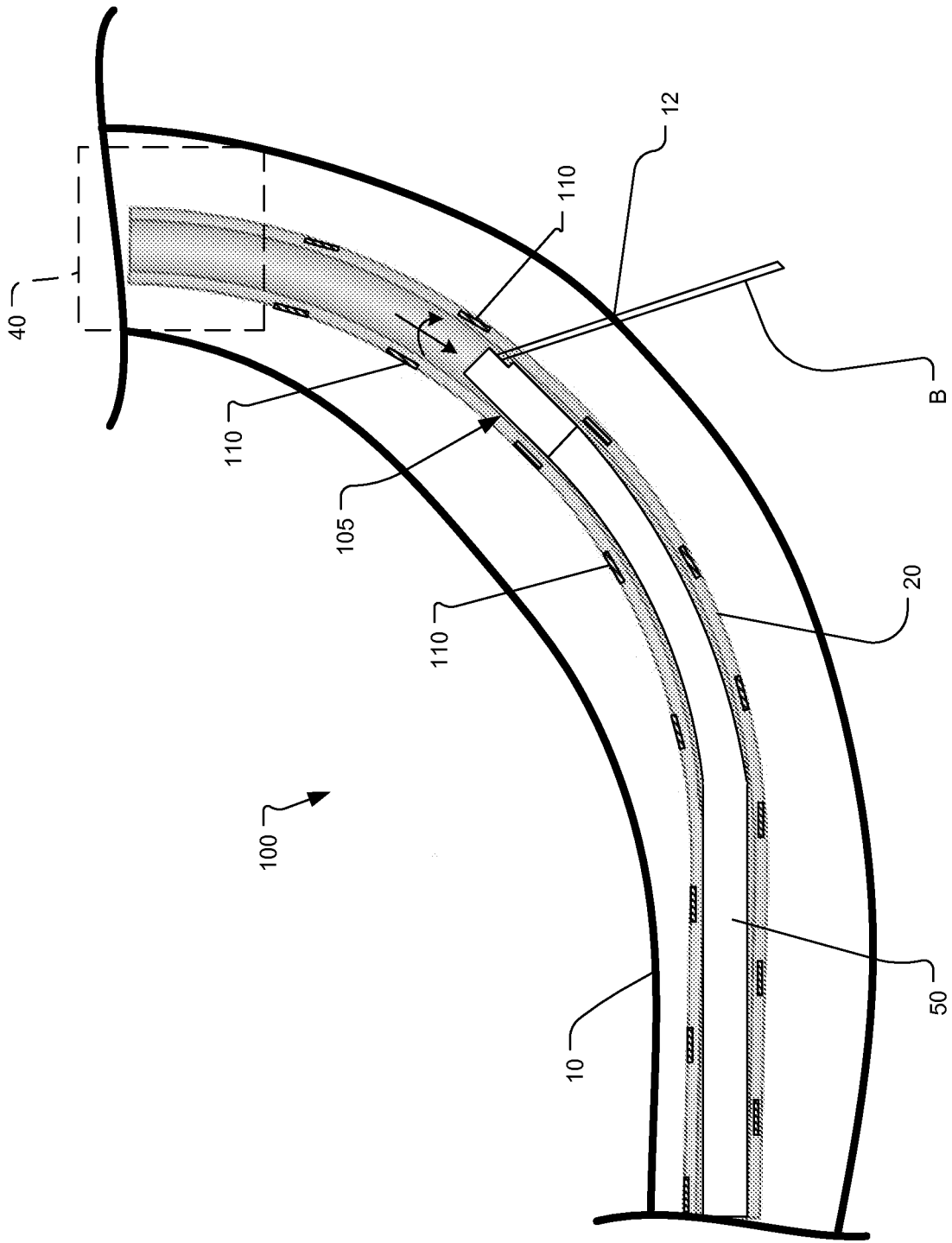


Fig. 8A

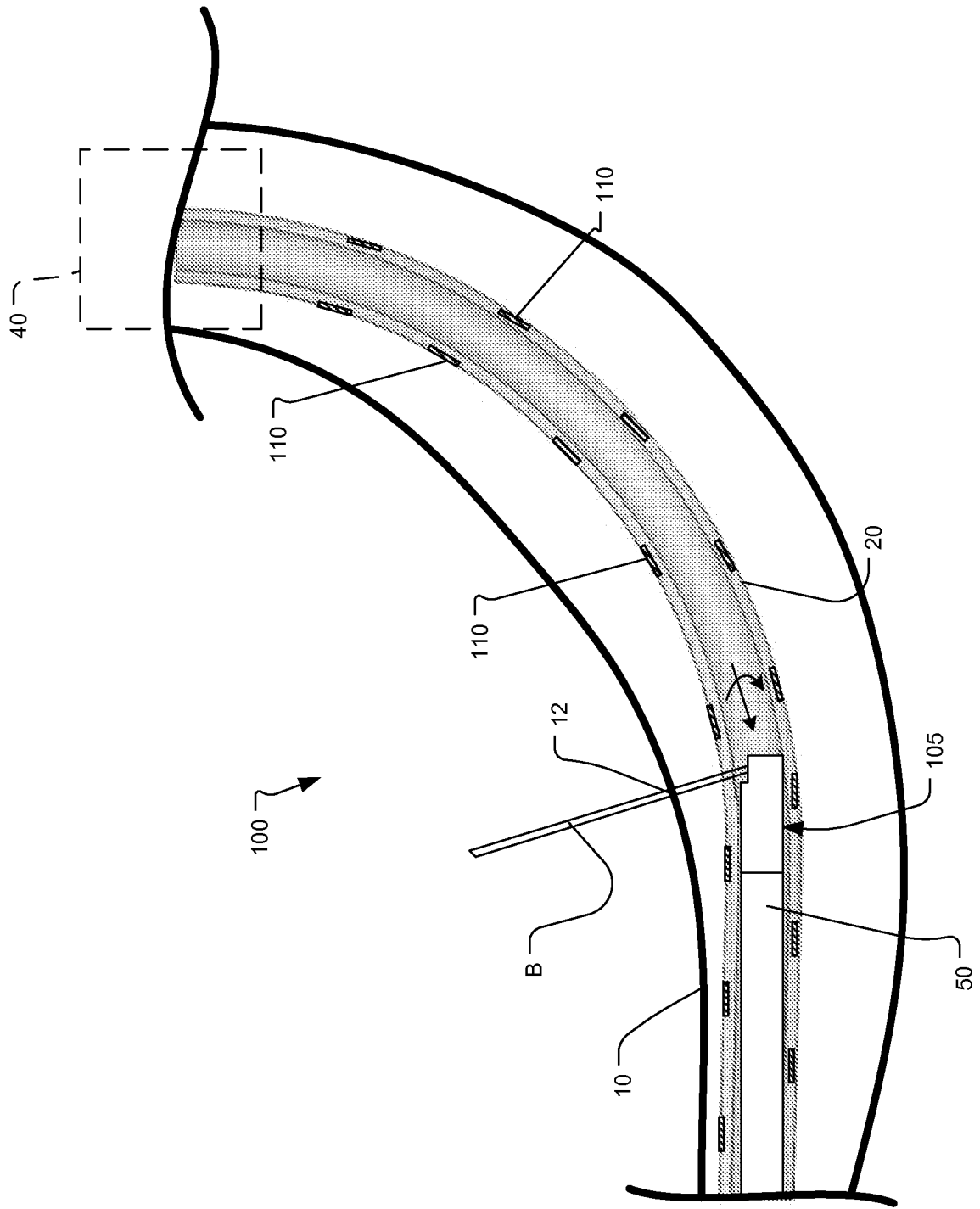


Fig. 8B

Process of Manufacturing Pressure Sensors in Sheath

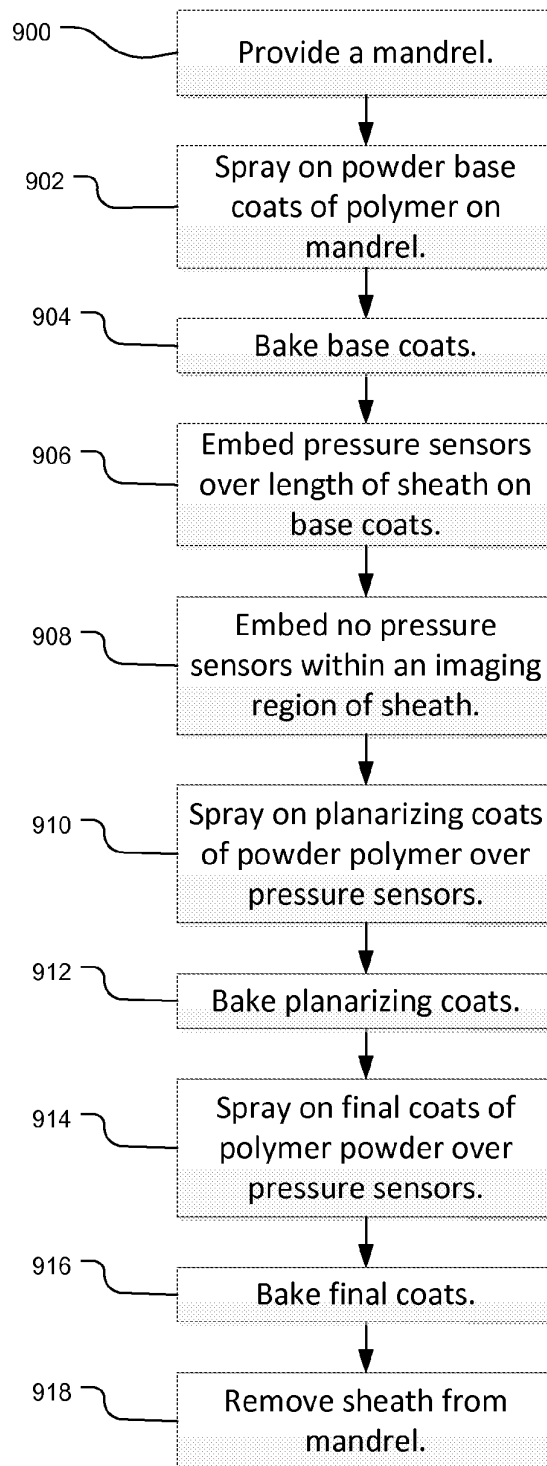


Fig. 9

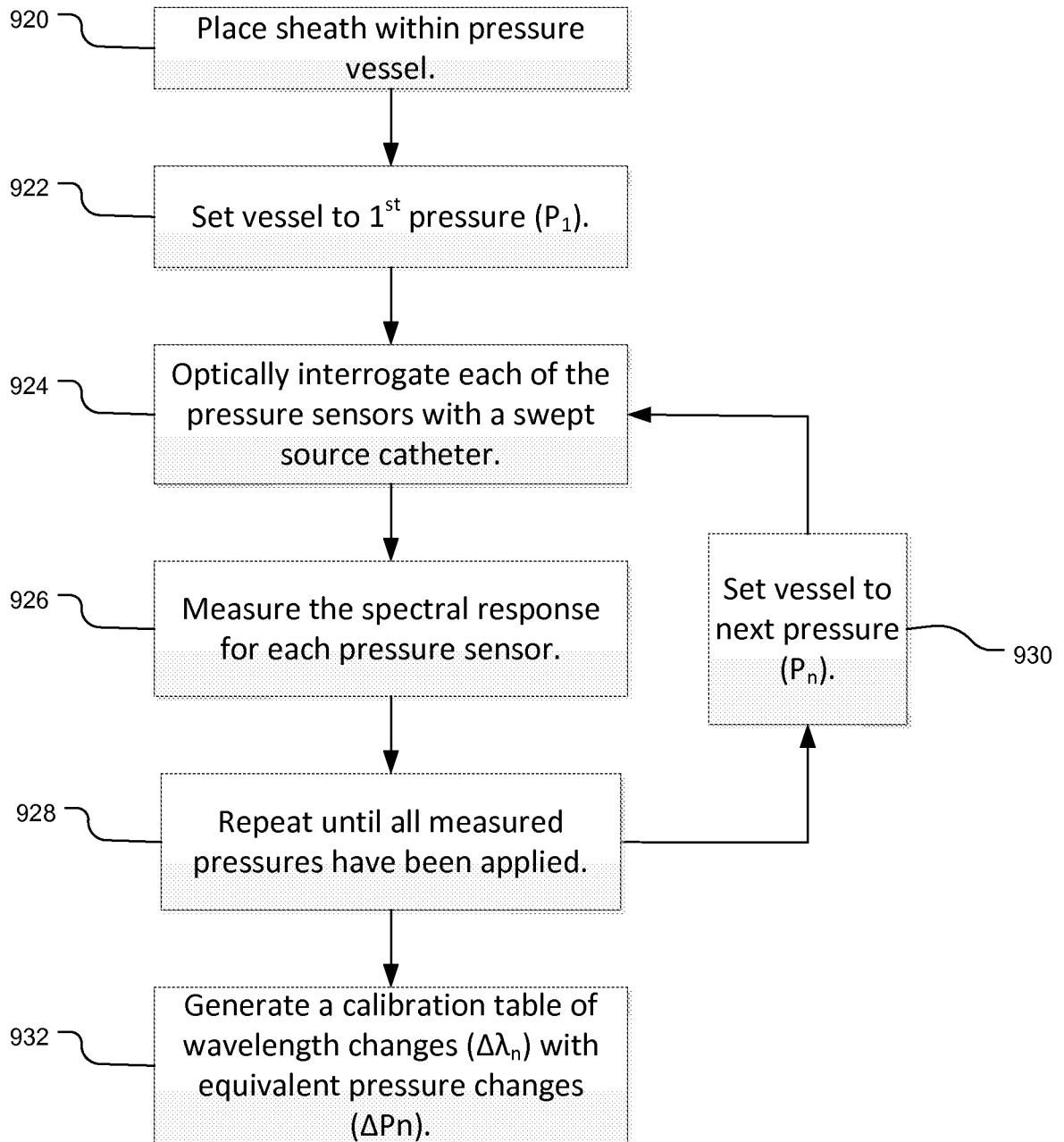
Calibration of Pressure Sensors based on Pressure Measurements

Fig. 10

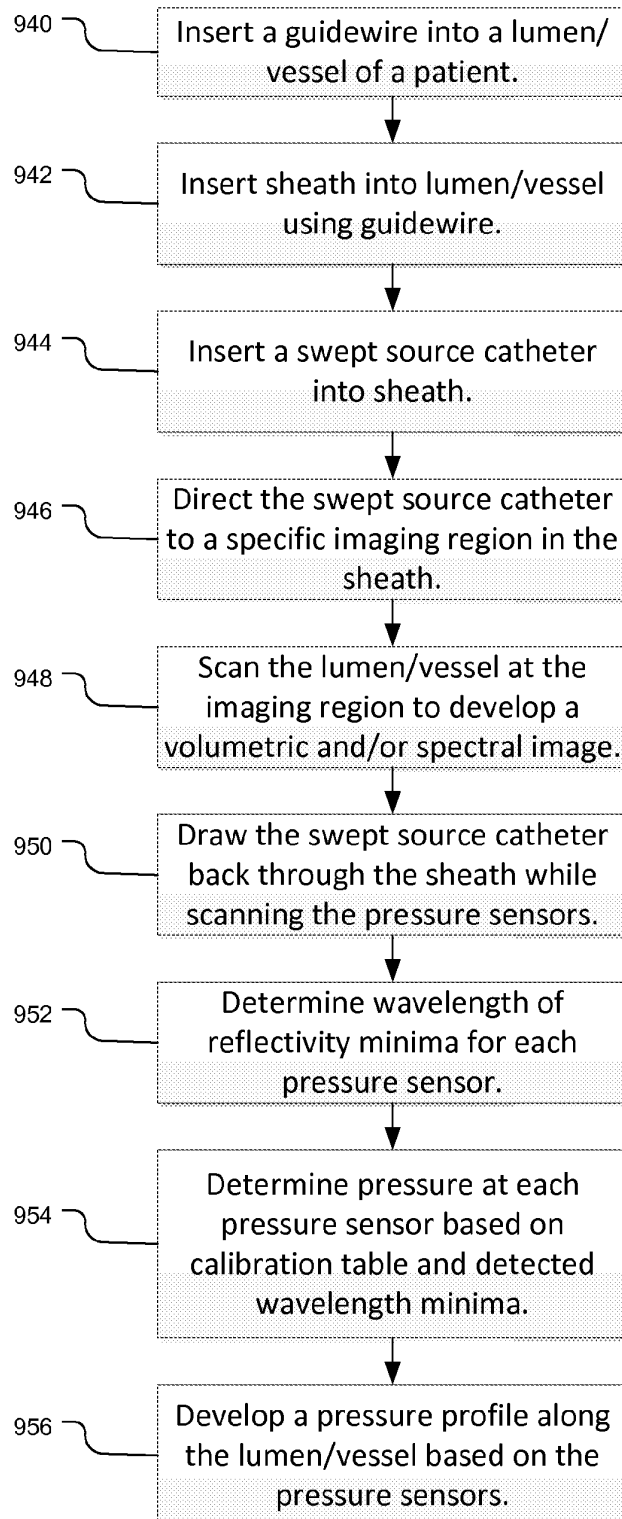
Method of using pressure sensors with swept source catheter

Fig. 11

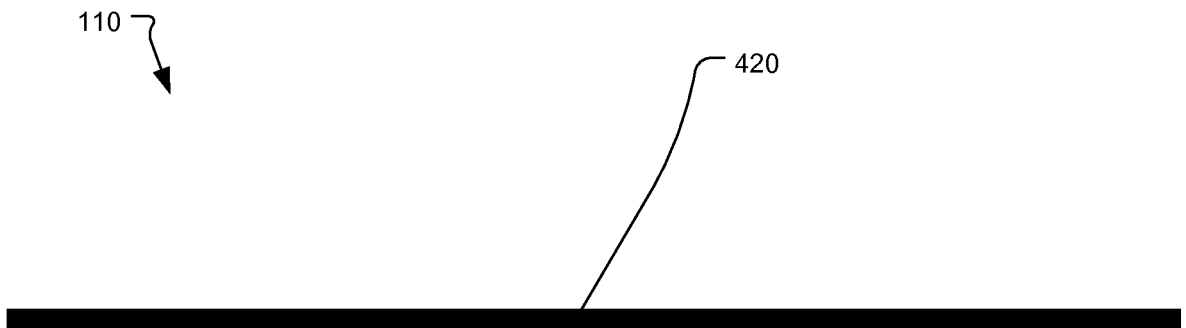


Fig. 12

REFERENCES CITED IN THE DESCRIPTION

This list of references cited by the applicant is for the reader's convenience only. It does not form part of the European patent document. Even though great care has been taken in compiling the references, errors or omissions cannot be excluded and the EPO disclaims all liability in this regard.

Patent documents cited in the description

- US 20040263857 A1 [0007]
- US 7415049 B1 [0046]
- US 7061618 B2 [0047]
- US 55329509 A [0047]
- US 20110051148 A1 [0047]
- US 77637310 A [0047]
- US 20110051143 A1 [0047]
- US 6665458 B [0060]

Non-patent literature cited in the description

- **R. HUBER ; M. WOJTKOWSKI ; J. G. FUJIMOTO.**
Fourier Domain Mode Locking (FDML): A new laser operating regime and applications for optical coherence tomography. *OPTICS EXPRESS*, 17 April 2006, vol. 14 (8), 3225 [0046]

专利名称(译)	带光学可探测传感器的护套		
公开(公告)号	EP2931116A1	公开(公告)日	2015-10-21
申请号	EP2013818866	申请日	2013-12-10
[标]申请(专利权)人(译)	火山公司		
申请(专利权)人(译)	火山CORPORATION		
当前申请(专利权)人(译)	火山CORPORATION		
[标]发明人	FLANDERS DALE C		
发明人	FLANDERS, DALE C.		
IPC分类号	A61B5/00 A61M25/00 A61B5/0215 A61B5/01		
CPC分类号	A61B5/02154 A61B1/04 A61B5/0002 A61B5/0066 A61B5/0084 A61B5/01 A61B5/02156 A61B5/02158 A61B5/6852 A61B2562/0247 A61B2562/0271 A61B2562/043 A61B2562/12 A61B2562/164		
代理机构(译)	博尔特WADE TENNANT		
优先权	13/712368 2012-12-12 US		
其他公开文献	EP2931116B1		
外部链接	Espacenet		

摘要(译)

一种血管内传感器系统，包括用于检测压力和/温度的压力和/或温度传感器阵列。在一个示例中，用光学导管询问传感器。在该示例中，扫描源能够获取患者血管或动脉的图像和压力/温度数据。在另一个例子中，血管内压力传感器系统具有在护套壁中嵌有压力传感器的护套。其他示例包括制造和使用血管内压力传感器系统的过程。