



(11) **EP 2 085 025 A1**

(12) **EUROPEAN PATENT APPLICATION**

(43) Date of publication:
05.08.2009 Bulletin 2009/32

(51) Int Cl.:
A61B 5/00 (2006.01) **A61B 5/0285 (2006.01)**
A61B 5/08 (2006.01)

(21) Application number: **09001352.5**

(22) Date of filing: **30.01.2009**

(84) Designated Contracting States:
AT BE BG CH CY CZ DE DK EE ES FI FR GB GR HR HU IE IS IT LI LT LU LV MC MK MT NL NO PL PT RO SE SI SK TR
Designated Extension States:
AL BA RS

- **Kojima, Takeshi**
Shinjuku-ku
Tokyo (JP)
- **Ushijima, Ryouzuke**
Shinjuku-ku
Tokyo (JP)

(30) Priority: **31.01.2008 JP 2008021997**

(74) Representative: **Grünecker, Kinkeldey, Stockmair & Schwanhäusser**
Anwaltssozietät
Leopoldstrasse 4
80802 München (DE)

(71) Applicant: **Nihon Kohden Corporation**
Shinjuku-ku
Tokyo (JP)

(72) Inventors:
• **Ono, Yoshinobu**
Shinjuku-ku
Tokyo (JP)

(54) **Autonomic nerve activity measuring apparatus and autonomic nerve activity measuring method**

(57) An autonomic nerve activity measuring apparatus includes: a pulse wave acquiring unit, configured to acquire at least two pulse wave signals from a living body; an electric stimulation unit, configured to apply electric

stimulation to the living body; a comparison unit, configured to compare the pulse wave signals acquired by the pulse wave acquiring unit; and an analysis unit, configured to analyze comparison result provided by the comparison unit.

FIG. 1

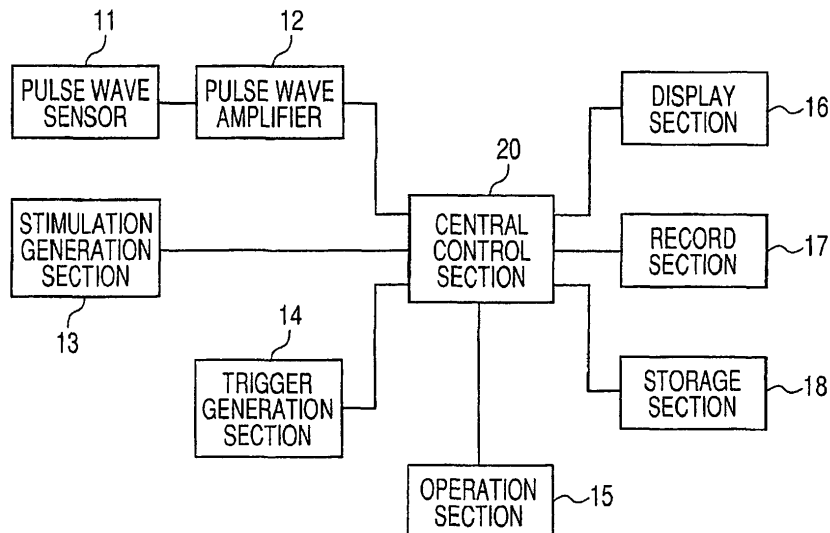

EP 2 085 025 A1

DescriptionBACKGROUND OF THE INVENTION

[0001] This invention relates to an autonomic nerve activity measuring apparatus and an autonomic nerve activity measuring method for applying electric stimulation to a living body and measuring autonomic nerve activity from a pulse wave signal reflecting the constriction of a peripheral blood vessel by an autonomic nerve (sympathetic nerve and parasympathetic nerve).

[0002] A skin blood volume, an electrocardiogram waveform, etc., is representative biological information to measure the autonomic nervous system and an attempt has been made to evaluate the state of the autonomic nervous and the balance and the functionality as to which of the sympathetic nerve and the parasympathetic nerve is dominant from the heart rate and the blood pressure and frequency analysis and chaos analysis of the digital pulse volume and further pulse wave acceleration of the digital pulse volume, etc.

[0003] For example, there are a related art of evaluating the autonomic nerve function from the a-a (systolic early positive wave) time pulse wave acceleration (refer to JP-A-2004-358022), and a related art of measuring a pulse wave for about 20 seconds and determining autonomic nerve imbalance from a distribution of peak and bottom times for each beat (refer to JP-A-2007-61572, particularly "embodiment 2").

[0004] However, although qualitative evaluation and analysis of the autonomic nerve can be conducted, disturbance of the visual sense, the acoustic sense, the smell sense, etc., has an effect on evaluating of the autonomic nerve and it is difficult to selectively evaluate the function of the sympathetic nerve and the function of the parasympathetic nerve.

[0005] Generally, if the measuring time is short, information required for diagnosis is insufficient and an error becomes large. On the other hand, considering that heart rate fluctuation has periodicity, if the measuring time is simply prolonged, the effect of the disturbance is easily received and it cannot be said that the prolonged measuring time is advantageous. That is, to conduct autonomic nerve activity measurement with no error, how long the measuring time is to be set cannot quantitatively be determined.

[0006] With the circumstances as described above as the background, an objective diagnosis of the state of the autonomic nerve is conducted by applying stimulation by an acoustic signal and an image signal and keeping track of the response time and the restoration potential of the autonomic nerve from fluctuation of vital sign (Refer to JP-A-2005-329148, particularly 0033). However, a problem remains in that the diagnosis can be applied only to a person having a normal audio visual function, and under the present circumstances, there is a demand for realizing an apparatus and a method for performing excellent autonomic nerve activity measurement.

[0007] Further, generally inspiration in respiration of a living body derives from the sympathetic nerve and expiration derives from the parasympathetic nerve. Therefore, the expiration becomes a disturbance factor of sympathetic nerve measurement from the relation between the respiration and the sympathetic nerve.

SUMMARY

[0008] It is therefore an object of the invention to provide an autonomic nerve activity measuring apparatus and measuring method capable of conducting autonomic nerve activity measuring more than was previously possible.

[0009] It is another object of the invention to provide an apparatus and a method capable of excluding disturbance deriving from respiration and determining the nature inspection of a sympathetic nerve.

[0010] In order to achieve the object, according to the invention, there is provided an autonomic nerve activity measuring apparatus comprising:

- a pulse wave acquiring unit, configured to acquire at least two pulse wave signals from a living body;
- an electric stimulation unit, configured to apply electric stimulation to the living body;
- a comparison unit, configured to compare the pulse wave signals acquired by the pulse wave acquiring unit; and
- an analysis unit, configured to analyze comparison result provided by the comparison unit.

[0011] The comparison unit may compare the pulse wave signals acquired by the pulse wave acquiring unit before and after the electric stimulation is applied to the living body.

[0012] The electric stimulation may include a first electric stimulation and a second electric stimulation which are different from each other in intensity. The comparison unit may compare the pulse wave signals acquired by the pulse wave acquiring unit when the first electric stimulation and the second electric stimulation are applied to the living body.

[0013] The first electric stimulation may have low intensity that the living body does not feel. The second electric stimulation may have high intensity that the living body feels.

[0014] The pulse wave signal may be at least one of amplitude of a P wave, amplitude of a T wave, amplitude of a D wave, amplitude of pulse wave velocity, amplitude of pulse wave acceleration, a pulse wave amplitude ratio, a pulse wave velocity amplitude ratio, a pulse wave acceleration amplitude ratio, a power fluctuation pattern of each wavelength provided by pulse wave frequency analysis, and an elastic coefficient.

[0015] The pulse wave amplitude ratio may include the ratio between the P wave and the D wave.

[0016] The pulse wave acceleration amplitude ratio

may include the ratio between a b wave and a d wave.

[0017] The autonomic nerve activity measuring apparatus may further include a respiration detection unit, configured to detect a respiration signal from the living body. The electric stimulation unit may apply the electric stimulation to the living body in response to the detected respiration signal.

[0018] The respiration detection unit may detect the respiration signal by using one of an airway flow sensor, a thermistor sensor, an airway pressure sensor, a carbon dioxide concentration sensor, an impedance sensor, and a photoplethysmographic sensor.

[0019] The respiration signal may include at least one of expiration and inspiration.

[0020] The electric stimulation unit may apply the electric stimulation to the living body in either an expiratory phase or an inspiratory phase.

[0021] In order to achieve the object, according to the invention, there is also provided a method of measuring autonomic nerve activity of a living body, the method comprising:

- acquiring at least two pulse wave signals from the living body;
- applying electric stimulation to the living body;
- comparing the acquired pulse wave signals; and
- analyzing comparison result.

[0022] The pulse wave signals, which are acquired before and after the electric stimulation is applied to the living body, may be compared.

[0023] The electric stimulation may include a first electric stimulation and a second electric stimulation which are different from each other in intensity. The pulse wave signals, which are acquired when the first electric stimulation and the second electric stimulation are applied to the living body, may be compared.

[0024] The first electric stimulation may have low intensity that the living body does not feel. The second electric stimulation may have high intensity that the living body feels.

[0025] The pulse wave signal may be at least one of amplitude of a P wave, amplitude of a T wave, amplitude of a D wave, amplitude of pulse wave velocity, amplitude of pulse wave acceleration, a pulse wave amplitude ratio, a pulse wave velocity amplitude ratio, a pulse wave acceleration amplitude ratio, a power fluctuation pattern of each wavelength provided by pulse wave frequency analysis, and an elastic coefficient.

[0026] The pulse wave amplitude ratio may include the ratio between the P wave and the D wave.

[0027] The pulse wave acceleration amplitude ratio may include the ratio between a b wave and a d wave.

[0028] The method may further include detecting a respiration signal from the living body. The electric stimulation may be applied to the living body in response to the detected respiration signal.

[0029] The respiration signal may be detected by using

one of an airway flow sensor, a thermistor sensor, an airway pressure sensor, a carbon dioxide concentration sensor, an impedance sensor, and a photoplethysmographic sensor.

5 **[0030]** The respiration signal may include at least one of expiration and inspiration.

[0031] The electric stimulation may be applied to the living body in either an expiratory phase or an inspiratory phase.

10

BRIEF DESCRIPTION OF THE DRAWINGS

[0032]

15

FIG. 1 is a block diagram of an embodiment of an autonomic nerve activity measuring apparatus according to the present invention.

FIGs. 2A and 2B are drawings to describe the names of parts in a pulse wave and pulse wave acceleration, respectively.

20

FIGs. 3A and 3B are drawings to show trends of pulse waves and pulse wave acceleration provided by the embodiment of the autonomic nerve activity measuring apparatus according to the invention.

25

FIG. 4 is a drawing to show pulse wave amplitude ratio trends of a normal person with no electric stimulation, provided by the embodiment of the autonomic nerve activity measuring apparatus according to the invention.

30

FIG. 5 is a drawing to show pulse wave amplitude ratio trends of the normal person with electric stimulation applied at the 11th pulse, provided by the embodiment of the autonomic nerve activity measuring apparatus according to the invention.

35

FIG. 6 is a drawing to show acceleration pulse wave amplitude ratio trends of the normal person with no electric stimulation, provided by the embodiment of the autonomic nerve activity measuring apparatus according to the invention.

40

FIG. 7 is a drawing to show acceleration pulse wave amplitude ratio trends of the normal person with electric stimulation applied at the 11th pulse, provided by the embodiment of the autonomic nerve activity measuring apparatus according to the invention.

45

FIG. 8 is a drawing to show pulse wave amplitude ratio trends of an abnormal person with electric stimulation applied at the 11th pulse, provided by the embodiment of the autonomic nerve activity measuring apparatus according to the invention.

50

FIG. 9 is a drawing to show acceleration pulse wave amplitude ratio trends of the abnormal person with electric stimulation applied at the 11th pulse, provided by the embodiment of the autonomic nerve activity measuring apparatus according to the invention.

55

FIG. 10 is a drawing to show a frequency distribution of a normal subject before and after the 14th pulse when an electric stimulation unit does not apply electric stimulation, provided by the embodiment of the

autonomic nerve activity measuring apparatus according to the invention.

FIG. 11 is a drawing to show a frequency distribution of the normal subject before and after the 14th pulse when the electric stimulation unit applies electric stimulation, provided by the embodiment of the autonomic nerve activity measuring apparatus according to the invention.

FIG. 12 is a drawing to show a frequency distribution of the abnormal subject before and after the 14th pulse when the electric stimulation unit applies electric stimulation, provided by the embodiment of the autonomic nerve activity measuring apparatus according to the invention.

FIG. 13 is a block diagram of an embodiment of an autonomic nerve activity measuring apparatus provided with a mechanism for excluding the effect of disturbance caused by respiration according to the invention.

DETAILED DESCRIPTION OF PREFERRED EMBODIMENTS

[0033] An embodiment of an autonomic nerve activity measuring apparatus and an autonomic nerve activity measuring method according to the invention will be discussed with reference to the accompanying drawings. FIG. 1 is a block diagram of the embodiment of the autonomic nerve activity measuring apparatus. A pulse wave signal is obtained using a pulse wave sensor 11 and is amplified by a pulse wave amplifier 12 according to a predetermined gain and then is fed into a central control section 20. A sensor including a light receiving element and a right transmitting element disclosed in JP-A-2001-78990 or the like can be used as the pulse wave sensor 11.

[0034] The pulse wave sensor 11 and the pulse wave amplifier 12 are a pulse wave acquiring unit for acquiring a pulse wave signal from a living body. The pulse wave acquiring unit may be capable of measuring at least one or more of photoplethysmograph, pressure pulse wave, blood flow, and blood pressure.

[0035] A stimulation generation section 13 containing an electrode put on a living body and a trigger generation section 14 are connected to the central control section 20. The stimulation generation section 13 and the trigger generation section 14 may make up an electric stimulation unit for applying electric stimulation to a living body by predetermined operation. As electric stimulation is generated from the stimulation generation section 13, the trigger generation section 14 generates a trigger signal and sends the trigger signal to the central control section 20.

[0036] An operation section 15 is connected to the central control section 20. The operation section 15 may be provided with keys, etc., for enabling the user to set a voltage value, a frequency, etc., to be generated from the stimulation generation section 13. The keys and the

trigger generation section 14 may be connected to the stimulation generation section 13 to make up an electric stimulation unit. The operation section 15 is also provided with keys for entering a command, data, etc., given to the central control section 20.

[0037] The central control section 20 is implemented as a CPU, etc., and has a comparison unit for making a comparison using a pulse wave signal acquired by the pulse wave acquiring unit and the trigger signal and an analysis unit for analyzing the comparison result.

[0038] A display section 16 of an LCD, etc., a record section 17 of a printer, etc., and a storage section 18 made up of various memory devices are connected to the central control section 20. The display section 16 and the record section 17 output the analysis result, etc., of the comparison unit and the analysis unit included in the central control section 20. Particularly, they make up an output unit for obtaining and outputting the result of comparison and analysis of pulse wave signals acquired before and after electric stimulation based on a trigger signal is applied and the result of comparison and analysis of pulse wave signals acquired when different intensity electric stimulations are applied. The acquired pulse waves, result, and the like are stored in the storage section 18. The expression "before and after electric stimulation based on a trigger signal" contains the case where the electric stimulation unit does not apply stimulation; if the electric stimulation unit applies stimulation, the expression contains obtaining the separate analysis results before and after the stimulation. It further contains obtaining the result across the time intervals before and after the stimulation containing the timing at which stimulation is applied by the electric stimulation unit.

[0039] Computation of the comparison unit and the analysis unit will be discussed. The pulse wave signal is a generic name for signals deriving from pulse waves described below. Specifically, the pulse wave signal is any one or more of the amplitude of a P wave, the amplitude of a T wave, the amplitude of a D wave, the amplitude of pulse wave velocity, the amplitude of pulse wave acceleration, a pulse wave amplitude ratio, a pulse wave velocity amplitude ratio, a pulse wave acceleration amplitude ratio, a power fluctuation pattern of each wavelength provided by pulse wave frequency analysis, and an elastic coefficient.

[0040] A one-period pulse wave is as shown in FIG. 2A. First derivative of the pulse wave is computed to provide a pulse wave velocity and further second derivative is computed by the comparison unit to provide pulse wave acceleration shown in FIG. 2B. The first peak in the one-period pulse wave is P wave called Percussion wave. The second peak in the one-period pulse wave is T wave called Tidal wave. The third peak in the one-period pulse wave is D wave called Dicrotic wave. The elastic coefficient is the height ratio between the two waves of the Percussion wave (P wave) and the Tidal wave (T wave).

[0041] The comparison unit performs computation for obtaining trends of the P wave and the D wave and also

trends of pulse wave amplitude ratios containing the ratio between the P wave and the D wave (P/D and D/P).

[0042] As another example, in the pulse wave acceleration shown in FIG. 2B, a positive wave having the first local maximum point is called a wave (systolic early positive wave) and a negative wave following the a wave is called b wave (systolic early negative wave), followed by c wave (systolic medium re-ascending wave), d wave (systolic late re-descending wave), and e wave (diastolic early positive wave). The comparison unit may perform computation for obtaining trends of b/a, c/a, d/a, e/a, and b/d as pulse wave acceleration amplitude ratios.

[0043] As still another example, the comparison unit may perform frequency resolution relative to the pulse wave and may perform computation for making a histogram with the frequency as an axis.

[0044] Each of the computations described above is also performed before and after stimulation of the electric stimulation unit and when different stimulation is applied, thereby finding the pulse wave signal comparison results such as a trend curve of pulse wave amplitude ratio (P/D, D/P), a trend curve of pulse wave acceleration amplitude ratio (b/a, c/a, d/a, e/a, b/d), and a pulse wave frequency component distribution. Further, the analysis unit evaluates the nature inspection of the sympathetic nerve according to change appearing in the pulse wave signal caused by the presence or absence of stimulation and the stimulation intensity difference based on the comparison results. The evaluation result may be output from the display section 16 and the record section 17.

[0045] The measuring result of the apparatus of the embodiment is shown. FIG. 3A shows pulse wave and pulse wave acceleration when the electric stimulation unit applies electric stimulation of extremely low intensity that a living body does not feel (the intensity may be zero), and FIG. 3B shows pulse wave and pulse wave acceleration when the electric stimulation unit applies electric stimulation of high intensity that a living body feels (here, 0.4-mA square-wave current with duration of 0.5 ms is used and five train stimulations are applied at 5.0-ms intervals); a trigger signal applies stimulation at time t. It is seen from FIG. 3A that the sympathetic nerve scarcely responds to the electric stimulation of low intensity and no change occurs in the pulse wave. On the other hand, it is seen from FIG. 3B that the sympathetic nerve responds to the electric stimulation of high intensity, constriction of a peripheral blood vessel occurs, and change occurs in the waveforms of the pulse wave and the acceleration pulse wave.

[0046] Further, FIGs. 4 to 7 show the measuring result of the apparatus of the embodiment. FIG. 4 shows pulse wave amplitude trends of a normal subject when the electric stimulation unit applies stimulation of low intensity. FIG. 5 shows pulse wave amplitude trends of the normal subject when the electric stimulation unit applies stimulation of high intensity. FIG. 6 shows acceleration pulse wave amplitude trends of a normal subject when the electric stimulation unit applies stimulation of low intensity.

FIG. 7 shows pulse wave acceleration amplitude trends of the normal subject when the electric stimulation unit applies stimulation of high intensity. The horizontal axis indicates what number pulse each pulse of the pulse wave is, the left vertical axis indicates the amplitude value, and the right vertical axis indicates the amplitude ratio value. In this example, it is obvious from FIG. 5 that if electric stimulation of high intensity that a living body feels is applied at the 11th pulse, large change occurs at the 14th pulse. This means that response to applying electric stimulation is noticeable according to the computation result of the embodiment providing the ratio. Likewise, it can be acknowledged in FIG. 7 that noticeable change is measured in the ratio between the b and d waves in the acceleration pulse wave.

[0047] Further, FIGs. 8 and 9 show the measuring result of the apparatus of the embodiment. FIG. 8 shows pulse wave amplitude trends of an abnormal subject as for the autonomic nerve (simply, abnormal person) when the electric stimulation unit applies stimulation of high intensity. FIG. 9 shows acceleration pulse wave amplitude trends of the abnormal subject when the electric stimulation unit applies stimulation of high intensity.

[0048] FIG. 8 corresponds to FIG. 5, and FIG. 9 corresponds to FIG. 7. Although the same electric stimulation as the normal person is applied at the 11th pulse, change is not observed in the pulse wave or the acceleration pulse wave of the abnormal person after the electric stimulation, and the computation result is in large contrast with the computation result for the pulse wave of the normal person wherein change occurs at the 14th pulse. That is, it is considered that a nerve impulse caused by pain responsive to the electric stimulation is induced and the sympathetic nerve state as the reflection is measured, and the advantage of making it possible to easily measure abnormal response of the sympathetic nerve can be provided.

[0049] FIGs. 10 to 12 show the measuring result of the apparatus of the embodiment. FIG. 10 shows a frequency distribution of the normal subject before and after the 11th pulse when the electric stimulation unit applies electric stimulation of extremely low intensity that a living body does not feel. Frequency is taken on the horizontal axis, and power is taken on the vertical axis. From the result, it is seen that a frequency distribution be forming the pulse wave before the 11th pulse and a frequency distribution of forming the pulse wave after the 11th pulse scarcely differ in pulse wave signal.

[0050] FIG. 11 shows a frequency distribution of the normal subject before and after the 11th pulse when the electric stimulation unit applies electric stimulation that a living body feels. Frequency is taken on the horizontal axis, and power is taken on the vertical axis. From the result, it is seen that the arterial volume decreases because of constriction of a peripheral blood vessel and a low frequency component increases in the frequency distribution of forming the pulse wave after the 11th pulse as compared with the frequency distribution be forming

the pulse wave before the 11th pulse.

[0051] FIG. 12 shows a frequency distribution of the abnormal subject before and after the 11th pulse when the electric stimulation unit applies electric stimulation. Frequency is taken on the horizontal axis, and degree (relative value) is taken on the vertical axis. From the result, it is seen that a frequency distribution be forming the pulse wave before the 11th pulse and a frequency distribution af forming the pulse wave after the 11th pulse scarcely differ although electric stimulation is applied, and it is understood that if high electric stimulation is applied, the sympathetic nerve does not appropriately respond to the electric stimulation and constriction of a peripheral blood vessel does not occur. This means that abnormal response of the sympathetic nerve can be acknowledged.

[0052] The embodiment described above can be applied not only to inspection of the nerve function, but also to evaluation of abnormal pain sense caused by diabetes, sympathoplegia caused by Parkinson's disease, etc.

[0053] Further, an embodiment for excluding the effect of disturbance caused by respiration will be discussed with FIG. 13. The configuration differs from that of the embodiment in FIG. 1 only in a respiration detection unit 19. The respiration detection unit 19 contains at least one of an airway flow sensor, a thermistor (temperature) sensor, an airway pressure sensor, a carbon dioxide concentration sensor, an impedance sensor, and a photoplethysmographic sensor.

[0054] The respiration detection unit 19 detects an airway (respiration) signal of a living body, for example, expiration and inspiration. When detecting expiration or inspiration, the respiration detection unit 19 sends a notification of detection of expiration or inspiration to a central control section 20. Upon reception of the notification, the central control section 20 instructs an electric stimulation generation section 13 to apply stimulation in an expiratory phase or an inspiratory phase of respiration.

[0055] Electric stimulation is applied at the timing of the expiratory phase or the inspiratory phase of respiration, whereby it is made possible to lessen the disturbance factor of sympathetic nerve measuring caused by respiration.

[0056] According to an aspect of the invention, a nerve impulse caused by pain responsive to the electric stimulation is induced and the pulse wave signal deriving from constriction of a peripheral blood vessel appearing as the reflection is measured, whereby it is made possible to evaluate the nature inspection of a sympathetic nerve. Further, it is also made possible to easily detect abnormal response of the homeostatic of the sympathetic nerve. Response of a pulse wave signal can be quickly obtained by applying electric stimulation different from a sound or light. Reaction can be displayed distinctly according to the pulse wave amplitude ratio and the pulse wave acceleration amplitude ratio. The range is widened according to the frequency component and the measurement result can be provided for facilitating analysis and eval-

uation.

[0057] The pulse wave amplitude ratio includes the ratio between the P wave and the D wave, and the pulse wave acceleration amplitude ratio includes the ratio between the b wave and the d wave, so that reaction can be displayed distinctly according to the ratios.

[0058] It is made possible to exclude the effect of disturbance caused by respiration and evaluate the nature inspection of a sympathetic nerve with high accuracy.

[0059] The possibility is also high that the invention may be applied not only to inspection of the nerve function, but also to fields of evaluation of abnormal pain sense caused by diabetes, sympathoplegia caused by Parkinson's disease, etc., and the like.

Claims

1. An autonomic nerve activity measuring apparatus comprising:

a pulse wave acquiring unit, configured to acquire at least two pulse wave signals from a living body;

an electric stimulation unit, configured to apply electric stimulation to the living body;

a comparison unit, configured to compare the pulse wave signals acquired by the pulse wave acquiring unit; and

an analysis unit, configured to analyze comparison result provided by the comparison unit.

2. The autonomic nerve activity measuring apparatus as claimed in claim 1, wherein

the comparison unit compares the pulse wave signals acquired by the pulse wave acquiring unit before and after the electric stimulation is applied to the living body.

3. The autonomic nerve activity measuring apparatus as claimed in claim 1, wherein

the electric stimulation includes a first electric stimulation and a second electric stimulation which are different from each other in intensity, and the comparison unit compares the pulse wave signals acquired by the pulse wave acquiring unit when the first electric stimulation and the second electric stimulation are applied to the living body.

4. The autonomic nerve activity measuring apparatus as claimed in claim 3, wherein

the first electric stimulation has low intensity that the living body does not feel, and the second electric stimulation has high intensity that the living body feels.

5. The autonomic nerve activity measuring apparatus as claimed in claim 1, wherein

- the pulse wave signal is at least one of amplitude of a P wave, amplitude of a T wave, amplitude of a D wave, amplitude of pulse wave velocity, amplitude of pulse wave acceleration, a pulse wave amplitude ratio, a pulse wave velocity amplitude ratio, a pulse wave acceleration amplitude ratio, a power fluctuation pattern of each wavelength provided by pulse wave frequency analysis, and an elastic coefficient.
6. The autonomic nerve activity measuring apparatus as claimed in claim 5, wherein the pulse wave amplitude ratio includes the ratio between the P wave and the D wave.
7. The autonomic nerve activity measuring apparatus as claimed in claim 5, wherein the pulse wave acceleration amplitude ratio includes the ratio between a b wave and a d wave.
8. The autonomic nerve activity measuring apparatus as claimed in claim 1, further comprising a respiration detection unit, configured to detect a respiration signal from the living body, wherein the electric stimulation unit applies the electric stimulation to the living body in response to the detected respiration signal.
9. The autonomic nerve activity measuring apparatus as claimed in claim 8, wherein the respiration detection unit detects the respiration signal by using one of an airway flow sensor, a thermistor sensor, an airway pressure sensor, a carbon dioxide concentration sensor, an impedance sensor, and a photoplethysmographic sensor.
10. The autonomic nerve activity measuring apparatus as claimed in claim 8, wherein the respiration signal includes at least one of expiration and inspiration.
11. The autonomic nerve activity measuring apparatus as claimed in claim 8, wherein the electric stimulation unit applies the electric stimulation to the living body in either an expiratory phase or an inspiratory phase.
12. A method of measuring autonomic nerve activity of a living body, the method comprising:
- acquiring at least two pulse wave signals from the living body;
 - applying electric stimulation to the living body;
 - comparing the acquired pulse wave signals; and
 - analyzing comparison result.
13. The method as claimed in claim 12, wherein the pulse wave signals, which are acquired before and after the electric stimulation is applied to the living body, are compared.
14. The method as claimed in claim 12, wherein the electric stimulation includes a first electric stimulation and a second electric stimulation which are different from each other in intensity, and the pulse wave signals, which are acquired when the first electric stimulation and the second electric stimulation are applied to the living body, are compared.
15. The method as claimed in claim 14, wherein the first electric stimulation has low intensity that the living body does not feel, and the second electric stimulation has high intensity that the living body feels.
16. The method as claimed in claim 12, wherein the pulse wave signal is at least one of amplitude of a P wave, amplitude of a T wave, amplitude of a D wave, amplitude of pulse wave velocity, amplitude of pulse wave acceleration, a pulse wave amplitude ratio, a pulse wave velocity amplitude ratio, a pulse wave acceleration amplitude ratio, a power fluctuation pattern of each wavelength provided by pulse wave frequency analysis, and an elastic coefficient.
17. The method as claimed in claim 16, wherein the pulse wave amplitude ratio includes the ratio between the P wave and the D wave.
18. The method as claimed in claim 16, wherein the pulse wave acceleration amplitude ratio includes the ratio between a b wave and a d wave.
19. The method as claimed in claim 12, further comprising detecting a respiration signal from the living body, wherein the electric stimulation is applied to the living body in response to the detected respiration signal.
20. The method as claimed in claim 19, wherein the respiration signal is detected by using one of an airway flow sensor, a thermistor sensor, an airway pressure sensor, a carbon dioxide concentration sensor, an impedance sensor, and a photoplethysmographic sensor.
21. The method as claimed in claim 19, wherein the respiration signal includes at least one of expiration and inspiration.
22. The method as claimed in claim 19, wherein the electric stimulation is applied to the living body in either an expiratory phase or an inspiratory phase.

FIG. 1

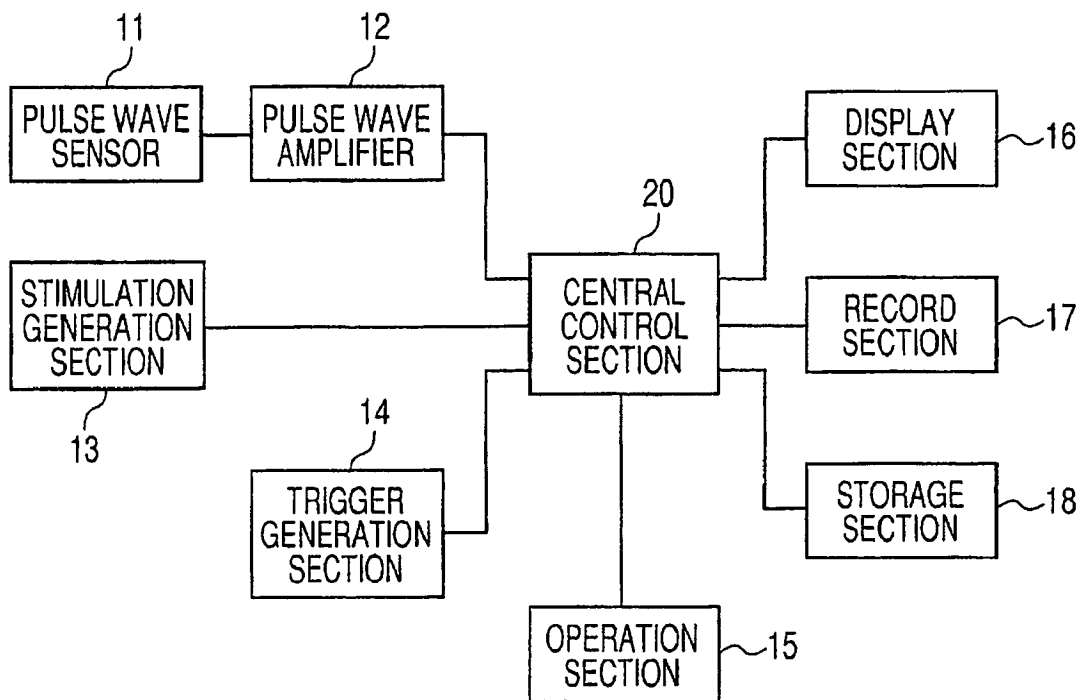

FIG. 2A

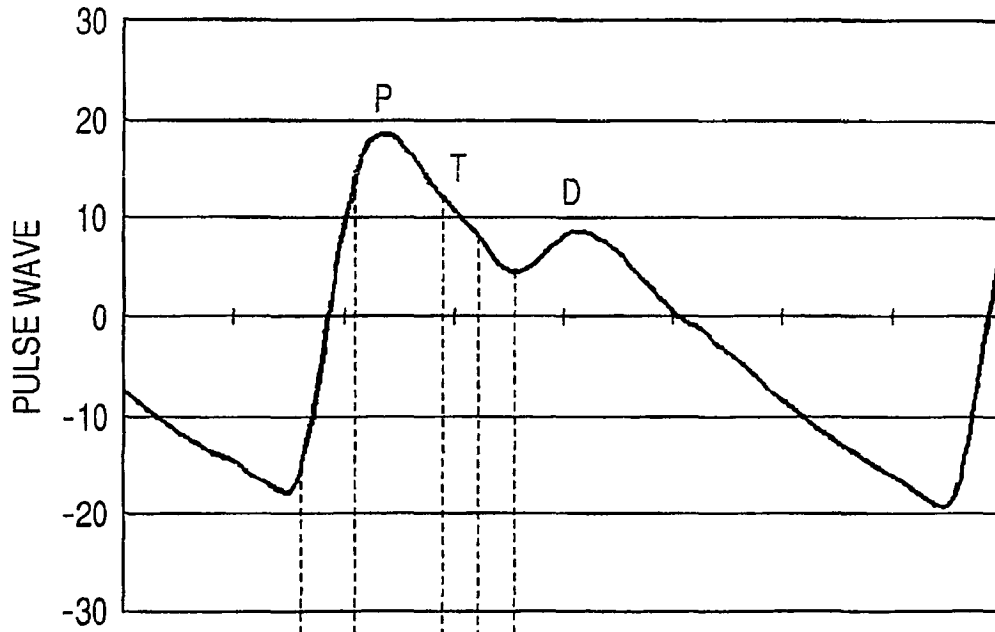

FIG. 2B

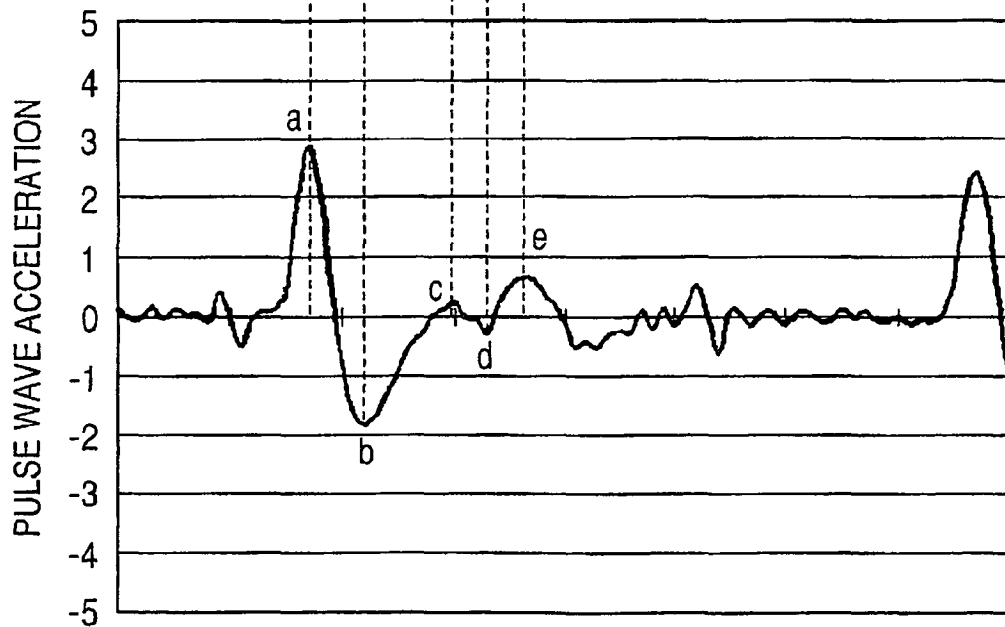

FIG. 3A

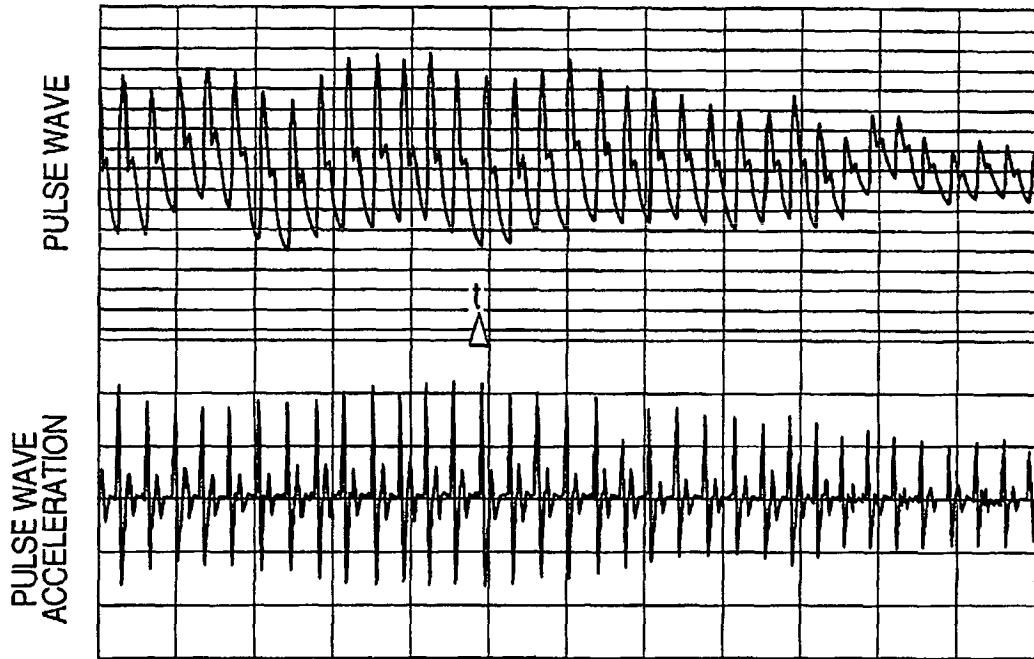

FIG. 3B

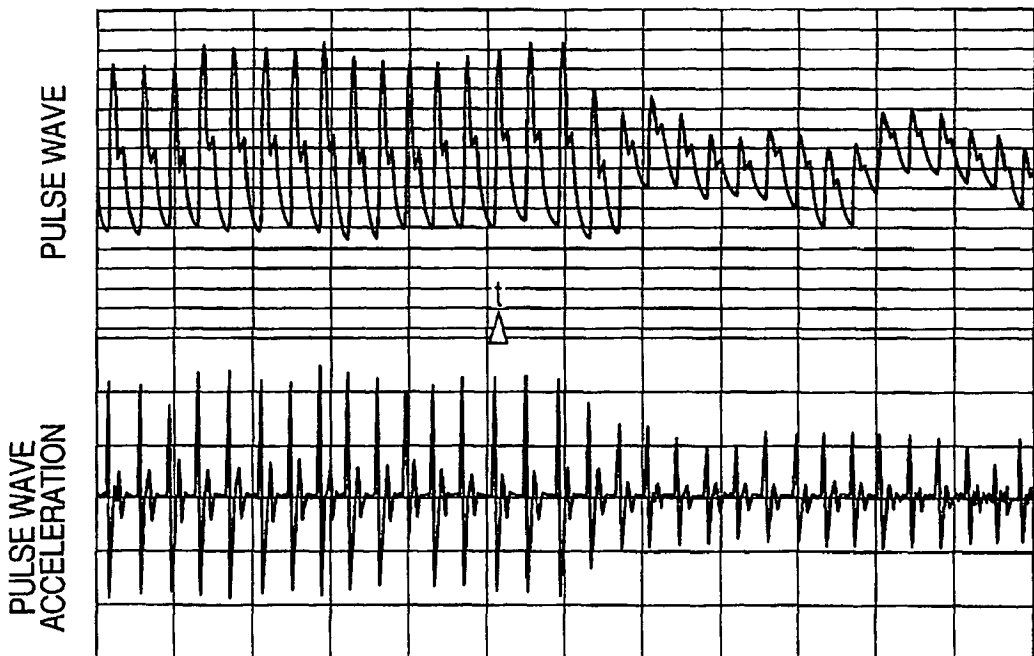

FIG. 4

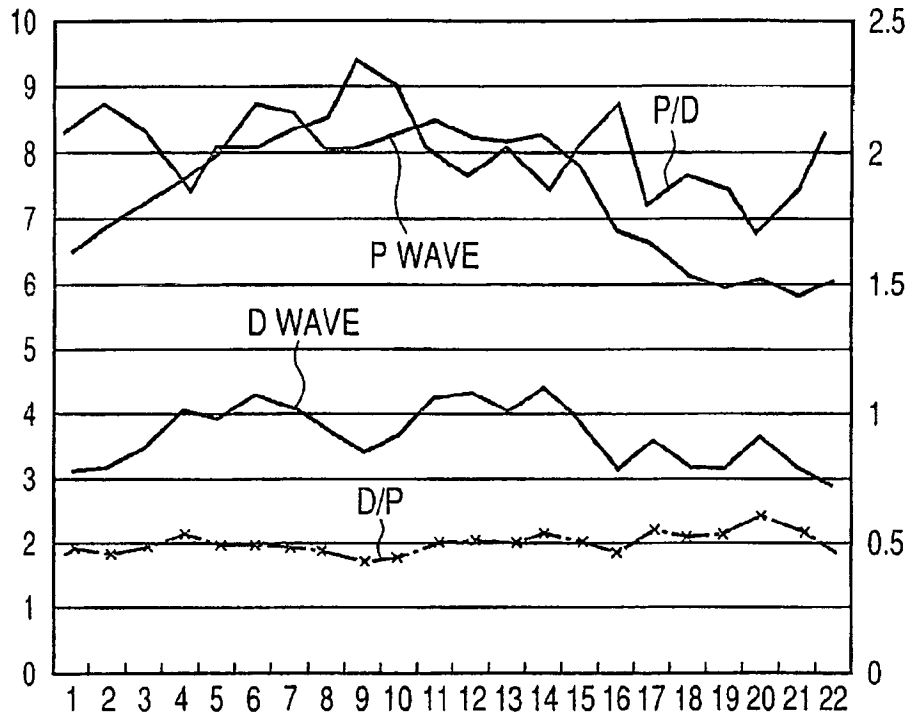

FIG. 5

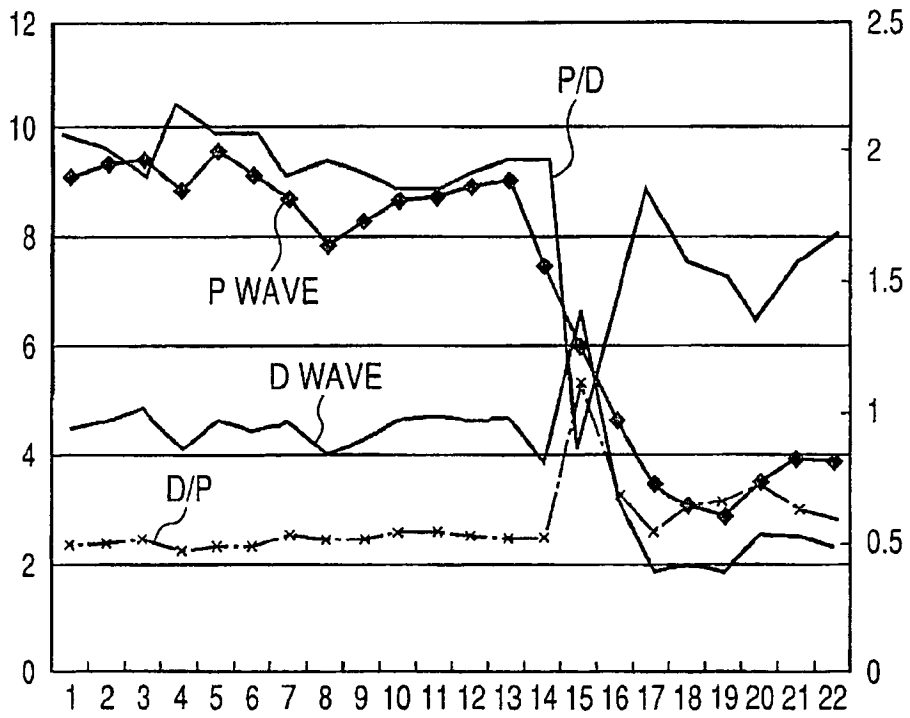

FIG. 6

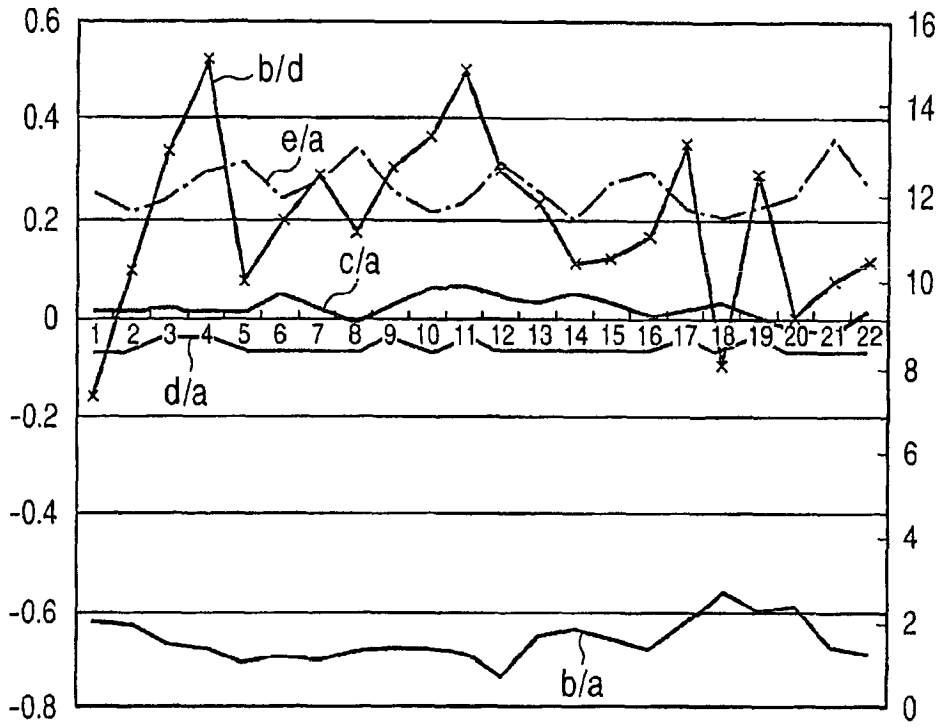

FIG. 7

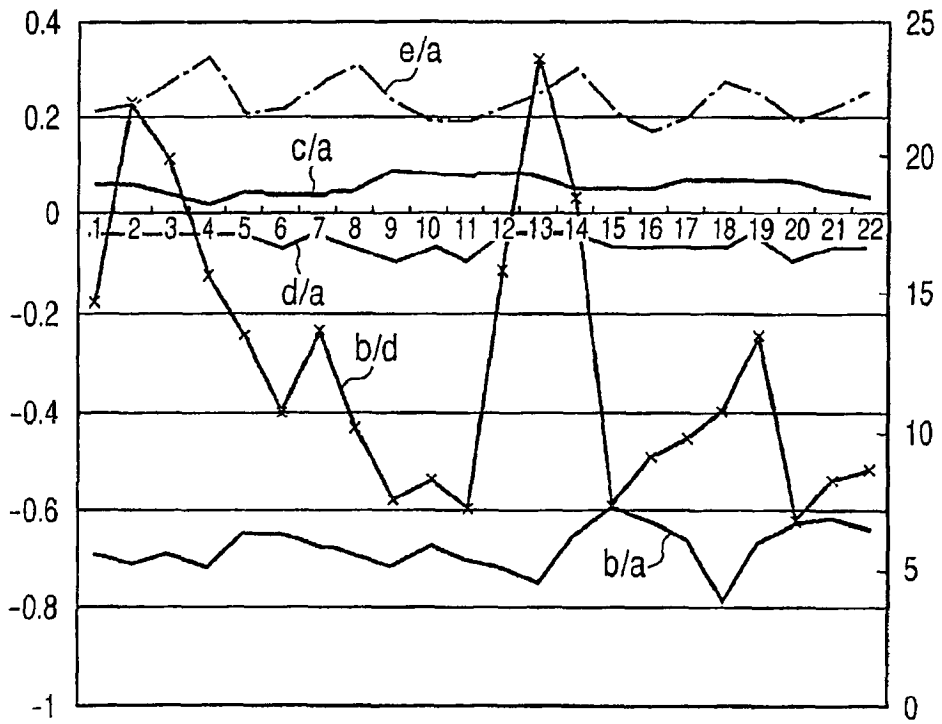

FIG. 8

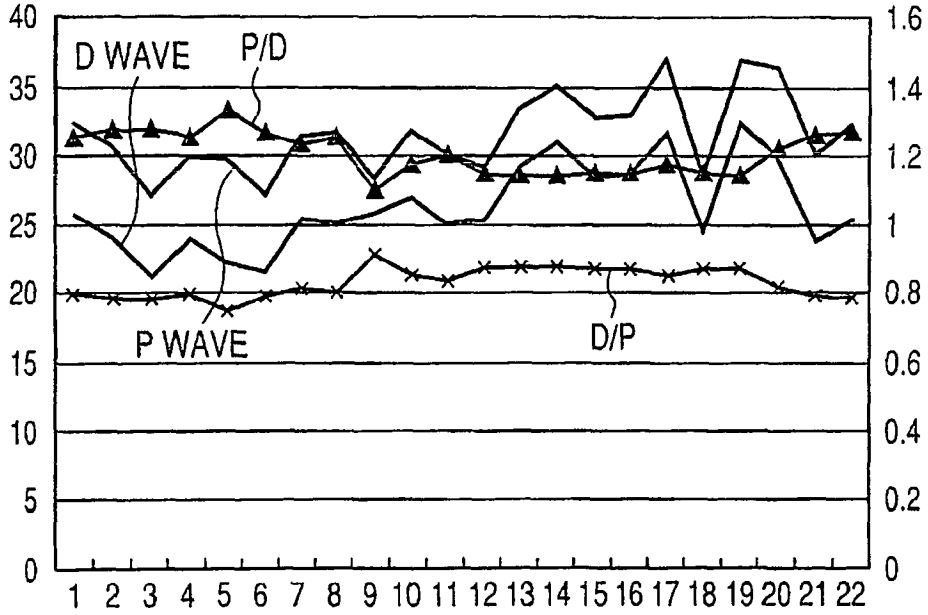

FIG. 9

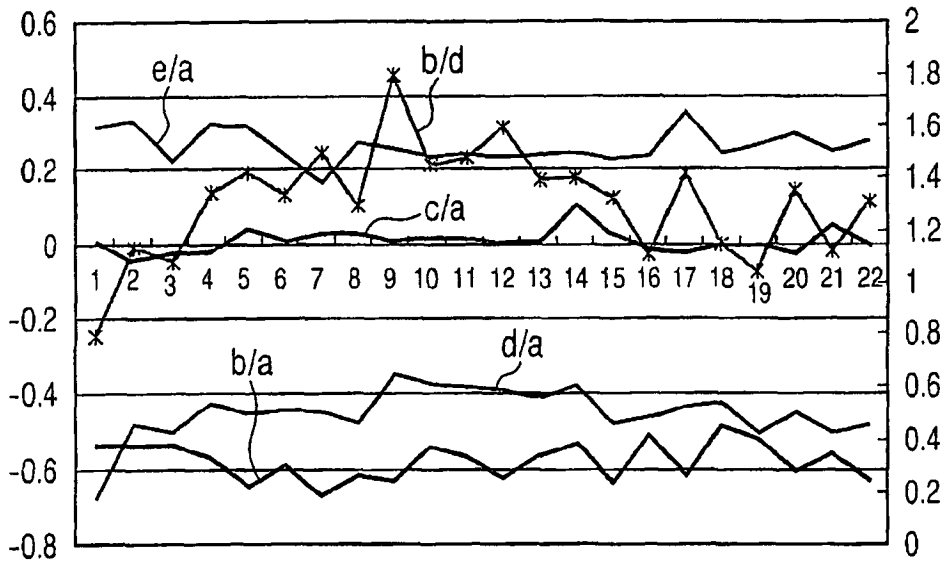

FIG. 10

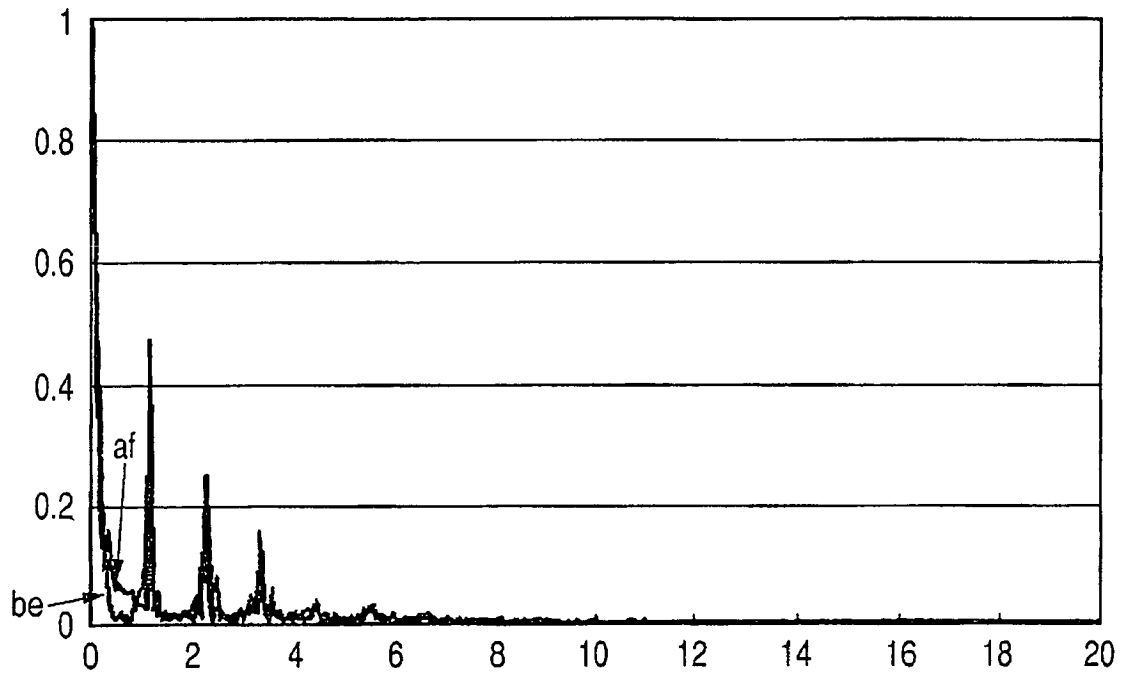

FIG. 11

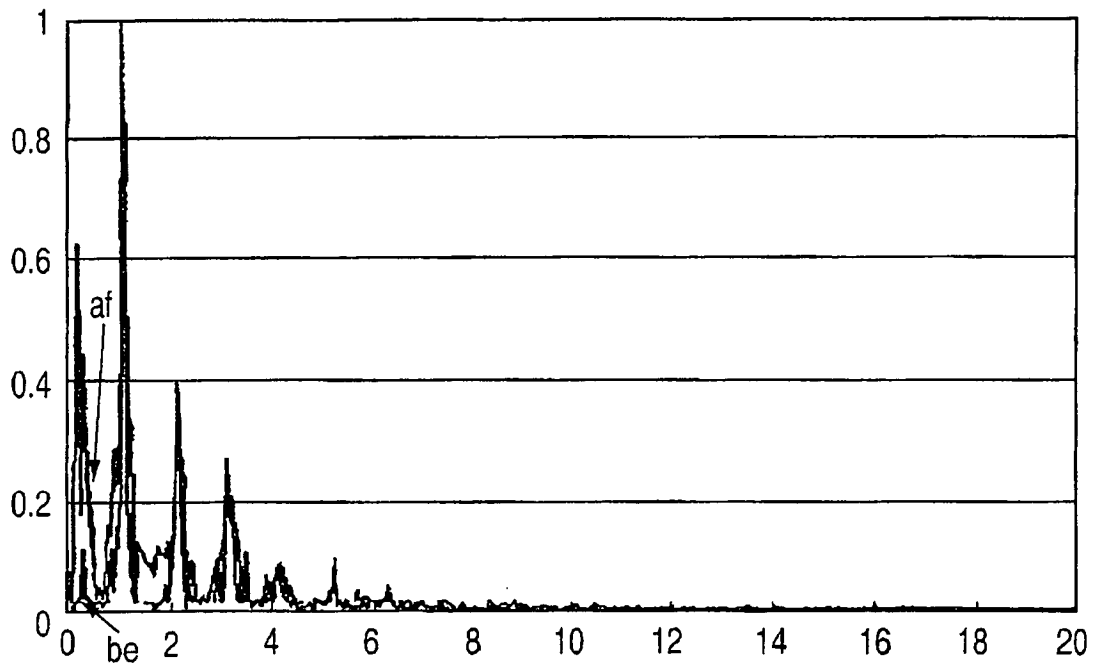

FIG. 12

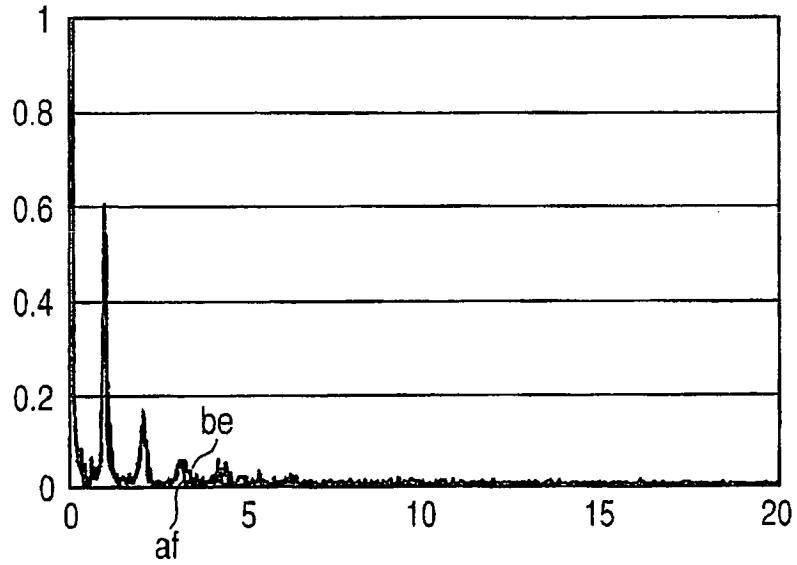
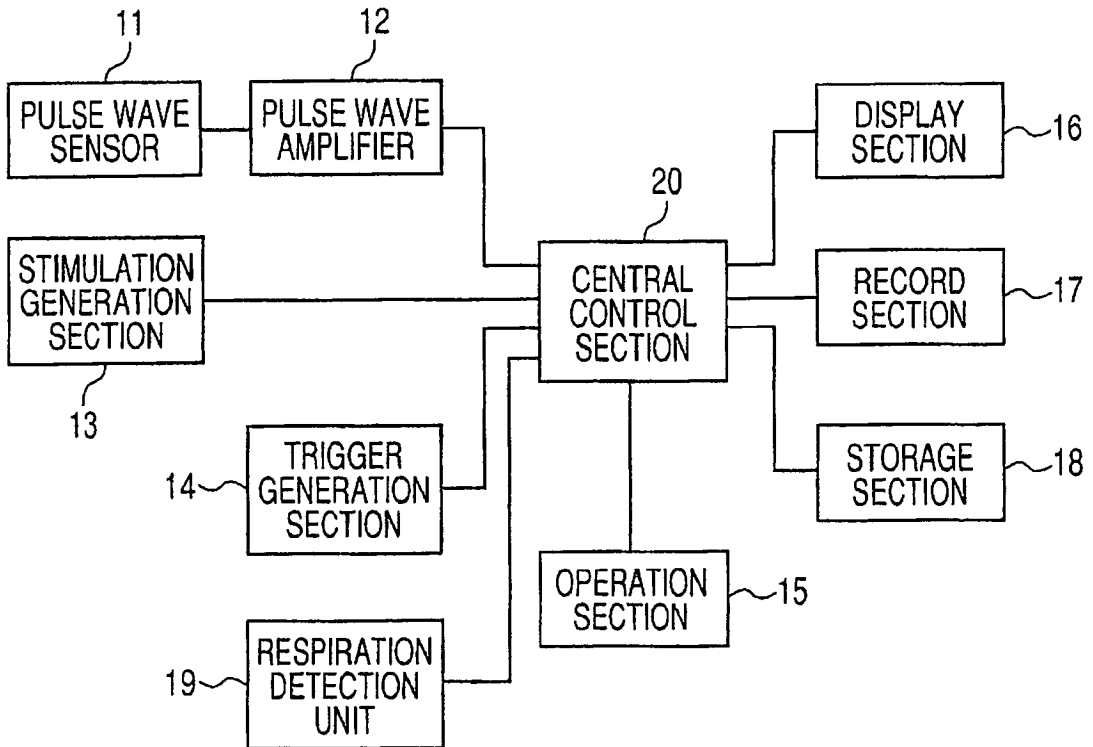

FIG. 13





EUROPEAN SEARCH REPORT

Application Number
EP 09 00 1352

DOCUMENTS CONSIDERED TO BE RELEVANT			
Category	Citation of document with indication, where appropriate, of relevant passages	Relevant to claim	CLASSIFICATION OF THE APPLICATION (IPC)
X	US 2006/149152 A1 (AMITZUR GIORA [IL] ET AL AMITZUR GIORA [IL] ET AL) 6 July 2006 (2006-07-06)	1-4, 8-15, 19-22	INV. A61B5/00 A61B5/0285
Y	* figures 1,3,4 *	5-7, 16-18	ADD. A61B5/08
A	----- EP 1 224 951 A (HEDGECOCK JAMES LEE [US]) 24 July 2002 (2002-07-24) * paragraphs [0013], [0020] *	3,4	
Y	----- US 2007/021673 A1 (ARBEL RONEN [IL] ET AL) 25 January 2007 (2007-01-25) * paragraphs [0001], [0002], [0017] - [0020], [0027], [0074] - [0076] * * paragraphs [0094], [0108] * * figures 2,3,7,8 *	5-7, 16-18	
A	----- JP 2004 351184 A (FUJII YASUO) 16 December 2004 (2004-12-16) * figure 2 * * page 5 *	7,18	
A	----- JP 2007 097678 A (UNIV HOKKAIDO) 19 April 2007 (2007-04-19) * paragraph [0005] *	8-11, 19-22	TECHNICAL FIELDS SEARCHED (IPC) A61B
A	----- JP 2003 339651 A (DENSO CORP) 2 December 2003 (2003-12-02) * paragraphs [0004], [0005] *	8,10,11, 19,21,22	
7 The present search report has been drawn up for all claims			
Place of search The Hague		Date of completion of the search 31 March 2009	Examiner De la Hera, Germán
CATEGORY OF CITED DOCUMENTS X : particularly relevant if taken alone Y : particularly relevant if combined with another document of the same category A : technological background O : non-written disclosure P : intermediate document		T : theory or principle underlying the invention E : earlier patent document, but published on, or after the filing date D : document cited in the application L : document cited for other reasons & : member of the same patent family, corresponding document	

EPO FORM 1503 03.82 (P04C01)

**ANNEX TO THE EUROPEAN SEARCH REPORT
ON EUROPEAN PATENT APPLICATION NO.**

EP 09 00 1352

This annex lists the patent family members relating to the patent documents cited in the above-mentioned European search report. The members are as contained in the European Patent Office EDP file on
The European Patent Office is in no way liable for these particulars which are merely given for the purpose of information.

31-03-2009

Patent document cited in search report	Publication date	Patent family member(s)	Publication date
US 2006149152 A1	06-07-2006	US 2008200820 A1	21-08-2008
EP 1224951 A	24-07-2002	NONE	
US 2007021673 A1	25-01-2007	NONE	
JP 2004351184 A	16-12-2004	NONE	
JP 2007097678 A	19-04-2007	NONE	
JP 2003339651 A	02-12-2003	JP 3770204 B2	26-04-2006

EPO FORM P0459

For more details about this annex : see Official Journal of the European Patent Office, No. 12/82

REFERENCES CITED IN THE DESCRIPTION

This list of references cited by the applicant is for the reader's convenience only. It does not form part of the European patent document. Even though great care has been taken in compiling the references, errors or omissions cannot be excluded and the EPO disclaims all liability in this regard.

Patent documents cited in the description

- JP 2004358022 A [0003]
- JP 2007061572 A [0003]
- JP 2005329148 A [0006]
- JP 2001078990 A [0033]

专利名称(译)	自主神经活动测量装置和自主神经活动测量方法		
公开(公告)号	EP2085025A1	公开(公告)日	2009-08-05
申请号	EP2009001352	申请日	2009-01-30
[标]申请(专利权)人(译)	日本光电工业株式会社		
申请(专利权)人(译)	日本光电公司		
当前申请(专利权)人(译)	日本光电公司		
[标]发明人	ONO YOSHINOBU KOJIMA TAKESHI USHIJIMA RYOUSUKE		
发明人	ONO, YOSHINOBU KOJIMA, TAKESHI USHIJIMA, RYOUSUKE		
IPC分类号	A61B5/00 A61B5/0285 A61B5/08		
CPC分类号	A61B5/0285 A61B5/0816 A61B5/4035 A61N1/3605		
优先权	2008021997 2008-01-31 JP		
其他公开文献	EP2085025B1		
外部链接	Espacenet		

摘要(译)

一种自主神经活动测量装置，包括：脉搏获取单元，用于从活体获取至少两个脉搏信号；电刺激单元，用于对生物体施加电刺激；比较单元，用于比较脉搏波获取单元获取的脉搏波信号；分析单元，用于分析比较单元提供的比较结果。

FIG. 1

