



- (51) **International Patent Classification:**
A61B 5/00 (2006.01) A61B 5/0452 (2006.01)
- (21) **International Application Number:**
PCT/US20 15/017775
- (22) **International Filing Date:**
26 February 2015 (26.02.2015)
- (25) **Filing Language:** English
- (26) **Publication Language:** English
- (30) **Priority Data:**
61/949,625 7 March 2014 (07.03.2014) US
- (71) **Applicant:** BOSTON SCIENTIFIC SCIMED, INC.
[US/US]; One Scimed Place, Maple Grove, Minnesota 55311 (US).
- (72) **Inventors:** LAUGHNER, Jacob I.; 141 4th Street E, Apt. 410, St. Paul, Minnesota 55101 (US). SHOME, Shibaji; 3538 Glenarden RD, Arden Hills, Minnesota 55112 (US). MEYER, Scott A.; 21912 Carrbridge Court, Lakeville, Minnesota 55044 (US).
- (74) **Agent:** WICKHEM, J. Scot; Seager, Tufte & Wickhem, LLC, 1221 Nicollet Ave, Suite 800, Minneapolis, Minnesota 55403 (US).

- (81) **Designated States** (unless otherwise indicated, for every kind of national protection available): AE, AG, AL, AM, AO, AT, AU, AZ, BA, BB, BG, BH, BN, BR, BW, BY, BZ, CA, CH, CL, CN, CO, CR, CU, CZ, DE, DK, DM, DO, DZ, EC, EE, EG, ES, FI, GB, GD, GE, GH, GM, GT, HN, HR, HU, ID, IL, IN, IR, IS, JP, KE, KG, KN, KP, KR, KZ, LA, LC, LK, LR, LS, LU, LY, MA, MD, ME, MG, MK, MN, MW, MX, MY, MZ, NA, NG, NI, NO, NZ, OM, PA, PE, PG, PH, PL, PT, QA, RO, RS, RU, RW, SA, SC, SD, SE, SG, SK, SL, SM, ST, SV, SY, TH, TJ, TM, TN, TR, TT, TZ, UA, UG, US, UZ, VC, VN, ZA, ZM, ZW.
- (84) **Designated States** (unless otherwise indicated, for every kind of regional protection available): ARIPO (BW, GH, GM, KE, LR, LS, MW, MZ, NA, RW, SD, SL, ST, SZ, TZ, UG, ZM, ZW), Eurasian (AM, AZ, BY, KG, KZ, RU, TJ, TM), European (AL, AT, BE, BG, CH, CY, CZ, DE, DK, EE, ES, FI, FR, GB, GR, HR, HU, IE, IS, IT, LT, LU, LV, MC, MK, MT, NL, NO, PL, PT, RO, RS, SE, SI, SK, SM, TR), OAPI (BF, BJ, CF, CG, CI, CM, GA, GN, GQ, GW, KM, ML, MR, NE, SN, TD, TG).

Published:
— with international search report (Art. 21(3))

(54) **Title:** MEDICAL DEVICES FOR MAPPING CARDIAC TISSUE

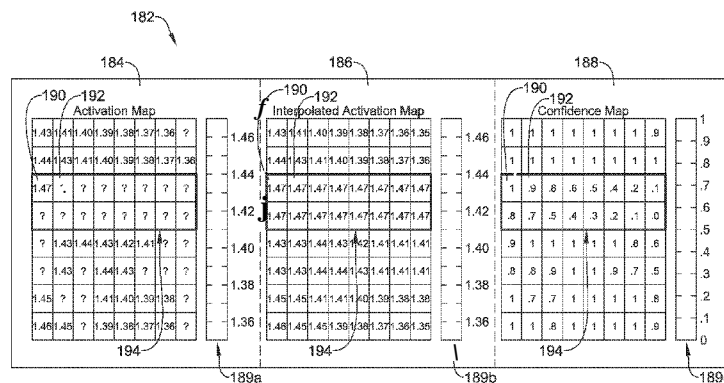

FIG. 10

(57) **Abstract:** Medical devices and methods for making and using medical devices are disclosed. An example medical device may include a catheter shaft with a plurality of electrodes coupled thereto and a processor coupled to the catheter shaft. The processor may be capable of collecting a set of signals from the plurality of electrodes and generating a data set from at least one of the set of signals. The data set may include at least one known data point and one or more unknown data points. The processor may also be capable of interpolating at least one of the unknown data points by conditioning the data set, assigning an interpolated value to at least one of the unknown data points, and assigning a confidence level to the interpolated value.

WO2015/134276 A1

MEDICAL DEVICES FOR MAPPING CARDIAC TISSUE

CROSS-REFERENCE TO RELATED APPLICATIONS

This application claims priority under 35 U.S.C. §119 to U.S. Provisional
5 Application Serial No. 61/949,625, filed March 7, 2014, the entirety of which is
incorporated herein by reference.

TECHNICAL FIELD

The present disclosure pertains to medical devices, and methods for
10 manufacturing medical devices. More particularly, the present disclosure pertains to
medical devices and methods for mapping and/or ablating cardiac tissue.

BACKGROUND

A wide variety of intracorporeal medical devices have been developed for
15 medical use, for example, intravascular use. Some of these devices include
guidewires, catheters, and the like. These devices are manufactured by any one of a
variety of different manufacturing methods and may be used according to any one of a
variety of methods. Of the known medical devices and methods, each has certain
advantages and disadvantages. There is an ongoing need to provide alternative
20 medical devices as well as alternative methods for manufacturing and using medical
devices.

BRIEF SUMMARY

The invention provides design, material, manufacturing method, and use
alternatives for medical devices. An example medical device is disclosed. The
25 medical device includes a catheter shaft with a plurality of electrodes coupled thereto.
A processor is coupled to the catheter shaft. The processor is capable of collecting a
set of signals from the plurality of electrodes and generating a data set from at least
one of the set of signals. The data set includes at least one known data point and one
or more unknown data points. The processor is also capable of interpolating at least
30 one of the unknown data points by conditioning the data set, assigning an interpolated
value to at least one of the unknown data points, and assigning a confidence level to
the interpolated value.

Alternatively or additionally to any of the embodiments above, collecting the set of signals includes determining an activation time at one or more of the plurality of electrodes.

Alternatively or additionally to any of the embodiments above, assigning a value to at least one of the unknown data points includes assigning an activation time to at least one of the unknown data points.

Alternatively or additionally to any of the embodiments above, determining the activation time includes identifying a fiducial point corresponding to a change in electrical potential and determining a time latency between a reference point and the fiducial point.

Alternatively or additionally to any of the embodiments above, interpolating at least one of the unknown data points by conditioning the data set includes creating a mesh of interconnected nodes between the known data points, the unknown data points, or both the known and unknown data points.

Alternatively or additionally to any of the embodiments above, interpolating at least one of the unknown data points by conditioning the data set includes upsampling the mesh of interconnected nodes.

Alternatively or additionally to any of the embodiments above, interpolating at least one of the unknown data points by conditioning the data set includes utilizing a non-linear distance between the known data points, unknown data points, or both the known and unknown data points.

Alternatively or additionally to any of the embodiments above, interpolating at least one of the unknown data points by conditioning the data set includes utilizing a geodesic distance between the known data points, unknown data points, or both the known and unknown data points.

Alternatively or additionally to any of the embodiments above, interpolating at least one of the unknown data points by conditioning the data set includes weighting the known data points and wherein weighting the known data points includes determining weighting coefficients from a weighting function.

Alternatively or additionally to any of the embodiments above, the processor is capable of generating a graphical display of at least one known data point, one or more unknown data points or both. The graphical display includes an activation map.

Alternatively or additionally to any of the embodiments above, the graphical display further comprises an interpolated activation map.

Alternatively or additionally to any of the embodiments above, the graphical display further comprises a confidence map representing the confidence level.

An example method for displaying cardiac mapping data is disclosed. The method includes storing a set of activation times on a memory. The set of activation
5 times includes one or more known activation times and one or more unknown activation times. The method also includes outputting the set of activation times to a display unit, displaying the activation times on a first panel of the display unit, interpolating the unknown activation times, displaying the interpolated activation times on a second panel of the display unit, and displaying a confidence map on a
10 third panel of the display unit. The confidence map displays the level of confidence for the interpolated activation times.

Alternatively or additionally to any of the embodiments above, storing a set of activation times on a memory includes identifying a fiducial point corresponding to a change in electrical potential and determining a time latency between a reference
15 point and the fiducial point.

Alternatively or additionally to any of the embodiments above, interpolating the unknown activation times includes utilizing a non-linear distance between two electrodes of a constellation catheter.

Alternatively or additionally to any of the embodiments above, interpolating
20 the unknown activation times includes utilizing a geodesic distance two electrodes of a constellation catheter.

Alternatively or additionally to any of the embodiments above, interpolating the unknown activation times includes weighting the known activation times and wherein weighting the known activation times includes determining weighting
25 coefficients from a weighting function.

An example medical device is disclosed. The medical device includes a catheter shaft with a plurality of electrodes coupled thereto. A processor is coupled to the catheter shaft. The processor is capable of sensing electrical activity with the plurality of electrodes and determining activation times at the plurality of electrodes
30 based on the sensed electrical activity. Determining activation times at the plurality of electrodes includes determining one or more known activation times and one or more unknown activation times. The processor is also capable of interpolating the one or more unknown activation times, assigning an interpolated activation time to

each of the one or more unknown activation times, and assigning a confidence level to the interpolated activation times.

Alternatively or additionally to any of the embodiments above, the processor is capable of generating a graphical display. The graphical display includes an activation map, an interpolated activation map, or both.

Alternatively or additionally to any of the embodiments above, the graphical display further comprises a confidence map representing the confidence level of the interpolated activation times.

The above summary of some embodiments is not intended to describe each disclosed embodiment or every implementation of the present disclosure. The Figures, and Detailed Description, which follow, more particularly exemplify these embodiments.

BRIEF DESCRIPTION OF THE DRAWINGS

The disclosure may be more completely understood in consideration of the following detailed description in connection with the accompanying drawings, in which:

Figure 1 is a schematic view of an example catheter system for accessing a targeted tissue region in the body for diagnostic and/or therapeutic purposes;

Figure 2 is a side view of an example mapping catheter;

Figure 3 is a schematic view of an example basket structure;

Figure 4 is an illustration of an example activation map displaying known and unknown activation times;

Figure 5 is an illustration of an example electrode mesh;

Figure 6 is an illustration of an example upsampled electrode mesh;

Figure 7 is an illustration of an example weighting function;

Figure 8 is an illustration of an example conditioned weighting function;

Figure 9 illustrates an example probability distance matrix; and

Figure 10 illustrates an example display.

While the disclosure is amenable to various modifications and alternative forms, specifics thereof have been shown by way of example in the drawings and will be described in detail. It should be understood, however, that the intention is not to limit the invention to the particular embodiments described. On the contrary, the intention is to cover all modifications, equivalents, and alternatives falling within the spirit and scope of the disclosure.

DETAILED DESCRIPTION

For the following defined terms, these definitions shall be applied, unless a different definition is given in the claims or elsewhere in this specification.

All numeric values are herein assumed to be modified by the term "about,"
5 whether or not explicitly indicated. The term "about" generally refers to a range of numbers that one of skill in the art would consider equivalent to the recited value (e.g., having the same function or result). In many instances, the terms "about" may include numbers that are rounded to the nearest significant figure.

The recitation of numerical ranges by endpoints includes all numbers within
10 that range (e.g. 1 to 5 includes 1, 1.5, 2, 2.75, 3, 3.80, 4, and 5).

As used in this specification and the appended claims, the singular forms "a", "an", and "the" include plural referents unless the content clearly dictates otherwise. As used in this specification and the appended claims, the term "or" is generally employed in its sense including "and/or" unless the content clearly dictates otherwise.

15 It is noted that references in the specification to "an embodiment", "some embodiments", "other embodiments", etc., indicate that the embodiment described may include one or more particular features, structures, and/or characteristics. However, such recitations do not necessarily mean that all embodiments include the particular features, structures, and/or characteristics. Additionally, when particular
20 features, structures, and/or characteristics are described in connection with one embodiment, it should be understood that such features, structures, and/or characteristics may also be used connection with other embodiments whether or not explicitly described unless clearly stated to the contrary.

The following detailed description should be read with reference to the
25 drawings in which similar elements in different drawings are numbered the same. The drawings, which are not necessarily to scale, depict illustrative embodiments and are not intended to limit the scope of the invention.

Mapping the electrophysiology of heart rhythm disorders often involves the introduction of a constellation catheter or other mapping/sensing device having a
30 plurality of electrodes and/or sensors (e.g., CONSTELLATION®, commercially available from Boston Scientific) into a cardiac chamber. The sensors detect the electric activity of the heart at sensor locations. It may be desirable to have the electric activity processed into electrogram signals that accurately represent cellular excitation through cardiac tissue relative to the sensor locations. A processing system

may then analyze and output the signal to a display device. Further, the processing system may output the signal as an activation or vector field map. The physician may use the activation or vector field map to perform a diagnostic procedure.

5 However, in some cases the sensing electrodes may fail to accurately detect the electrical activity of heart. The failure of the electrodes to detect a signal may limit the ability of the processing system to accurately display information used for diagnostic procedures. For example, an activation map may be generated that contains missing information and/or inaccurate visual representations. Therefore, it may be desirable to replace poor or non-existent electrical signal information with
10 information that is believed to be accurate. In some instances, interpolation may be used to replace poor/missing data. Standard interpolation methods may have limitations due to both the temporal nature of the activation signals and the three-dimensional spatial configuration of sensing electrodes located in an anatomical region. The methods and systems disclosed herein are designed to overcome at least
15 some of the limitations of standard interpolation methods used to interpolate poor or non-existent activation signals. For example, some of the methods disclosed herein may utilize geodesic distance calculations in order to improve the accuracy of interpolation methods. Other methods and medical devices are also disclosed.

Figure 1 is a schematic view of a system 10 for accessing a target region 12 in
20 the body for diagnostic and/or therapeutic purposes. Figure 1 generally shows system 10 deployed in the left atrium of the heart. Alternatively, system 10 can be deployed in other regions of the heart, such as the left ventricle, right atrium, or right ventricle. While the illustrated embodiment shows system 10 being used for mapping and/or ablating myocardial tissue, system 10 (and the methods described herein) may
25 alternatively be configured for use in other tissue mapping and/or ablation applications, such as procedures for ablating or otherwise involving tissue in the prostate, brain, gall bladder, uterus, nerves, blood vessels and other regions of the body, including in systems that are not necessarily catheter-based.

System 10 may include a mapping catheter 14 and an ablation catheter 16.
30 Each probe 14/16 may be separately introduced into target region 12 through a vein or artery (e.g., the femoral vein or artery) using a suitable percutaneous access technique. Alternatively, mapping catheter 14 and ablation catheter 16 can be assembled in an integrated structure for simultaneous introduction and deployment in target region 12.

Mapping catheter 14 may include a catheter shaft 18. The distal end of the catheter shaft 18 may include a three-dimensional multiple electrode structure 20. Structure 20 may take the form of a basket having a plurality of struts 22 (see Figure 2), although other multiple electrode structures could be used. A plurality of mapping electrodes 24 (not explicitly shown on Figure 1, but shown on Figure 2) may be disposed along struts 22. Each electrode 24 may be configured to sense intrinsic physiological activity in the anatomical region. In some embodiments, electrodes 24 may be configured to detect activation signals of the intrinsic physiological activity within the anatomical structure (e.g., the activation times of cardiac activity).

Electrodes 24 may be electrically coupled to a processing system 32. A signal wire (not shown) may be electrically coupled to each electrode 24 on basket structure 20. The wires may extend through shaft 18 and electrically couple each electrode 24 to an input of processing system 32. Electrodes 24 may sense electrical activity in the anatomical region (e.g., myocardial tissue). The sensed activity (e.g., activation signals) may be processed by processing system 32, which may assist the physician by generating an electrical activity map (e.g., a vector field map, an activation time map, etc.) to identify the site or sites within the heart appropriate for a diagnostic and/or treatment procedure. For example, processing system 32 may identify a near-field signal component (e.g., activation signals originating from cellular tissue adjacent to the mapping electrode 24) or from an obstructive far-field signal component (e.g., activation signals originating from non-adjacent tissue). The near-field signal component may include activation signals originating from atrial myocardial tissue whereas the far-field signal component may include activation signals originating from ventricular myocardial tissue. The near-field activation signal component may be further analyzed to find the presence of a pathology and to determine a location suitable for ablation for treatment of the pathology (e.g., ablation therapy).

Processing system 32 may include dedicated circuitry (e.g., discrete logic elements and one or more microcontrollers; a memory or one or more memory units, application-specific integrated circuits (ASICs); and/or specially configured programmable devices, such as, for example, programmable logic devices (PLDs) or field programmable gate arrays (FPGAs)) for receiving and/or processing the acquired activation signals. In at least some embodiments, processing system 32 includes a general purpose microprocessor and/or a specialized microprocessor (e.g., a digital

signal processor, or DSP, which may be optimized for processing activation signals) that executes instructions to receive, analyze and display information associated with the received activation signals. In such implementations, processing system 32 can include program instructions, which when executed, perform part of the signal processing. Program instructions can include, for example, firmware, microcode or application code that is executed by microprocessors or microcontrollers. The above-mentioned implementations are merely exemplary. A variety of processing systems 32 are contemplated.

In some embodiments, processing system 32 may be configured to measure the electrical activity in the myocardial tissue adjacent to electrodes 24. For example, in some embodiments, processing system 32 may be configured to detect electrical activity associated with a dominant rotor or divergent activation pattern in the anatomical feature being mapped. Dominant rotors and/or divergent activation patterns may have a role in the initiation and maintenance of atrial fibrillation, and ablation of the rotor path, rotor core, and/or divergent foci may be effective in terminating the atrial fibrillation. In either situation, processing system 32 processes the sensed activation signals to generate a display of relevant characteristics, such as an isochronal map, activation time map, action potential duration (APD) map, a vector field map, a contour map, a reliability map, an electrogram, a cardiac action potential, and/or the like. The relevant characteristics may be used by the physician to identify a site suitable for ablation therapy.

Ablation catheter 16 may include a flexible catheter body 34 that carries one or more ablation electrodes 36. Electrodes 36 may be electrically connected to a radio frequency (RF) generator 37 (or other suitable energy source) that is configured to deliver ablation energy to electrodes 36. Ablation catheter 16 may be movable with respect to the anatomical feature to be treated, as well as the structure 20. Ablation catheter 16 may be positionable between or adjacent to electrodes 24 of structure 20, for example, when the one or more ablation electrodes 36 are positioned adjacent to target region 12.

Processing system 32 may output data to a suitable output or display device 40, which may display relevant information for a clinician. Device 40 may be a CRT, LED, or other type of display, a printer, or the like. Device 40 may be utilized to present the relevant characteristics in a format most useful to the physician. In addition, processing system 32 may generate position-identifying output for display

on device 40 that aids the physician in guiding ablation electrode(s) 36 into contact with tissue at the site identified for ablation.

Turning now to Figure 2, here some of the features of mapping catheter 14 can be seen. For example, Figure 2 illustrates that structure 20 an end cap 42 between
5 which struts 22 generally extend in a circumferentially spaced relationship. Struts 22 may be made of a resilient inert material, such as Nitinol, other metals, silicone rubber, suitable polymers, or the like and extend between a base region 41 and end cap 42 in a resilient, pretensioned condition, to bend and conform to the tissue surface they contact. In some embodiments, eight struts 22 may form structure 20.
10 Additional or fewer struts 22 could be used in other embodiments. As illustrated, each strut 22 may carry eight mapping electrodes 24. Additional or fewer mapping electrodes 24 could be disposed on each strut 22 in other embodiments. Various dimensions are contemplated for structure. For example, structure 20 may be relatively small (e.g., 40 mm or less in diameter). In alternative embodiments,
15 structure 20 may be smaller or larger (e.g., 40 mm in diameter or greater).

A slidable sheath 50 may be movable along the major axis of shaft 18. Moving sheath 50 distally relative to shaft 18 may cause sheath 50 to move over structure 20, thereby collapsing the structure 20 into a compact, low profile condition suitable for introduction into and/or removal from an interior space of an anatomical structure,
20 such as, for example, the heart. In contrast, moving the sheath 50 proximally relative to shaft 18 may expose structure 20, allowing structure 20 to elastically expand and assume the basket configuration illustrated in Figure 2.

A signal wire (not shown) may be electrically coupled to each mapping electrode 24. The wires may extend through shaft 18 of mapping catheter 20 (or
25 otherwise through and/or along shaft 18) into a handle 54, in which they are coupled to an external connector 56, which may be a multiple pin connector. Connector 56 may electrically couple mapping electrodes 24 to processing system 32. These are just examples. Some additional details regarding these and other example mapping systems and methods for processing signals generated by the mapping catheter can be
30 found in U.S. Patent Nos. 6,070,094, 6,233,491, and 6,735,465, the disclosures of which are hereby expressly incorporated herein by reference.

To illustrate the operation of the system 10, Figure 3 is a schematic side view of basket structure 20. In the illustrated embodiment, basket structure includes 64 mapping electrodes 24. Electrodes 24 may be disposed in groups of eight electrodes

(labeled 1, 2, 3, 4, 5, 6, 7, and 8) on each of eight struts 22 (labeled A, B, C, D, E, F, G, and H). While an arrangement of sixty-four mapping electrodes 24 is shown disposed on basket structure 20, mapping electrodes 24 may alternatively be arranged in different numbers (more or fewer splines and/or electrodes), on different structures, and/or in different positions. In addition, multiple basket structures can be deployed in the same or different anatomical structures to simultaneously obtain signals from different anatomical structures.

When basket structure 20 is positioned adjacent to the anatomical structure to be treated (e.g. left atrium, left ventricle, right atrium, or right ventricle of the heart), processing system 32 may be configured to record the activation signals from each electrode 24 channel related to physiological activity of the anatomical structure (e.g., the electrodes 24 measure electrical activation signals associated with the physiology of the anatomical structure). The activation signals of physiological activity may be sensed in response to intrinsic physiological activity or based on a predetermined pacing protocol instituted by at least one of the plurality of electrodes 24.

Electrodes 24 that contact healthy, responsive cellular tissue may sense a change in the voltage potential of a propagating cellular activation wavefront. Further, in a normal functioning heart, electrical discharge of the myocardial cells may occur in a systematic, linear fashion. Therefore, detection of non-linear propagation of the cellular excitation wavefront may be indicative of cellular firing in an abnormal fashion. For example, cellular firing in a rotating pattern may indicate the presence of dominant rotors and/or divergent activation patterns. Further, because the presence of the abnormal cellular firing may occur over localized target tissue regions, it is possible that electrical activity may change form, strength or direction when propagating around, within, among or adjacent to diseased or abnormal cellular tissue. Identification of these localized areas of diseased or abnormal tissue may provide a clinician with a location for which to perform a therapeutic and/or diagnostic procedure. For example, identification of an area including reentrant or rotor currents may be indicative of an area of diseased or abnormal cellular tissue. The diseased or abnormal cellular tissue may be targeted for an ablative procedure.

Figure 4 illustrates an example activation map 72 showing activation times sensed by electrodes 24. Activation map 72 may include a two-dimensional grid that visually represents mapping electrodes 24. For example, activation map 72 may include an 8x8 matrix displaying sixty-four (64) electrode spaces that represent the

sixty-four (64) electrodes on a constellation catheter or similar sensing device. Mapping electrodes 24 may be organized and/or identified by electrode number (e.g. electrodes 1-8) and spline location (e.g. splines A-H). Other combinations of electrodes and/or splines are contemplated.

5 The activation time for an electrode 24 may be defined as the time elapsed between an activation "event" being sensed on a target mapping electrode 24 and a reference electrode. For example, a space 70 on map 72 representing electrode 1 on strut A displays an activation time of 0.101 ms. However, it is possible that one or more electrodes 24 will be unable to sense and/or collect an activation time. For
10 example, one or more spaces like a space 71 representing electrode 1 on spline H may display a "?." The "?" may indicate that the particular electrode corresponding to that location on the multiple electrode structure 20 cannot sense an activation time. Therefore, the "?" may represent missing signal data. Missing signal data and/or an incomplete activation map may prevent the identification of diseased or abnormal
15 cellular tissue.

 Some embodiments may include generating a color map corresponding to activation map 72. Each unique activation time may be assigned a unique, differentiating color. It is contemplated that a variety of color combinations may be included in generating the color-based activation time map. Further, the color map
20 may be displayed on a display. Additionally, the color map may help a clinician identify the propagation direction of cellular firing. Activation map 72 may display an activation time or color for known signals and not display an activation time or color for unknown and/or missing activation time data. The use of color to differentiate activation times is just an example. It is contemplated that other means
25 may be used to differentiate activation times. For example, texture, symbols, numbers, or the like may be used as differentiating characteristics.

 In order to maximize the utility of activation map 72, it may be desirable to populate unknown activation times. Therefore, in some embodiments it may be desirable to interpolate activation times for missing signal data and populate and/or
30 fill in the activation time map 72 accordingly. In practice, it may be that electrodes 24 in close proximity to one another will experience similar cellular events (e.g. depolarization). For example, as a cellular activation wavefront propagates across an atrial surface, electrodes 24 in close proximity to one another will likely experience similar cellular activation times. Therefore, when selecting an interpolation method,

it may be desirable to select a method that incorporates the relative distance between neighboring electrodes and utilizes those distances in an algorithm to estimate unknown data points. One method to interpolate activation times and thereby fill in missing electrode data is to utilize an interpolation method that estimates the missing electrode data based on the electrode's relationship and/or proximity to known electrode data. The method may include identifying the physical position of all electrodes 24 in three-dimensional space, determining the distance between electrodes 24, and interpolating and/or estimating the missing electrode values. The estimated values may then be used to populate diagnostic displays (e.g. activation map). Therefore, the interpolation method may include any interpolation method that incorporates neighboring electrode information (e.g. distance between electrodes) in its estimation algorithm. Example interpolation methods may include Radial Basis Function (RBF) and/or Kriging interpolation. These are only examples. It is contemplated that other interpolation methods that incorporate neighboring data point information may be utilized with the embodiments disclosed herein.

As indicated above, some interpolation methods may incorporate the distance between electrodes as an input variable of their interpolation algorithm. For example, RBF and Kriging interpolation methods may incorporate the linear distance between unknown and known electrodes in their interpolation algorithms. The linear distance may be determined by calculating the "straight line" or "Euclidean" distance between electrodes 24. In non-curved space, it is generally understood that the shortest distance between two points is a straight line.

When collecting and analyzing the electrical activity of the heart, it may be desirable to collect and/or analyze the electrical activity as it is expressed and/or propagated through an anatomical region. It is generally understood that the anatomical shape of the interior walls of the heart are curved spaces. Further, because multiple electrode structure 20 may conform to the anatomical space in which it is deployed (e.g. heart chamber), electrodes 24 disposed on multiple electrode structure 20 may similarly conform to the anatomical space in which multiple electrode structure 20 is deployed. In practice, multiple electrode structure 20 is often deployed along the curved surface of an atrial chamber. In some embodiments it may be desirable to collect and/or analyze electrical activity as it occurs along the curved surface of an atrial chamber. Therefore, when incorporating the distance between electrodes into an interpolation method, it is often desirable to use the distance

between the electrodes along the curved surface of the cardiac chamber. In contrast, it is often less desirable to calculate the linear distance between electrodes through open space and/or blood. Further, assuming a fixed distance between electrodes and/or using the linear distance of the "nearest neighboring electrode" may result in
5 inaccurate and/or distorted results.

As stated, it may be desirable to substitute the curved distance between electrodes for the linear distance in some example interpolation methods. Geodesic distances may be understood to be the shortest distance between two points in curved space. Therefore, calculating the geodesic distance between two electrodes may
10 better approximate the distance between the two electrodes in curved space. An example method for calculating the geodesic distance may include creating a coarse triangular mesh between electrodes 24. The coarse triangular mesh may then be upsampled. The upsampled mesh may then be utilized to calculate the shortest distance between electrodes. Once the shortest distance between electrodes 24 has
15 been calculated, the geodesic distance between electrodes 24 may be calculated. After generating the geodesic distances between electrodes 24, the geodesic distances may be substituted for the linear distance between electrodes 24.

Figure 5 illustrates a mesh 60 representing the three-dimensional arrangement of mapping electrodes 24 deployed in a non-uniform or non-spherical configuration.
20 The mesh 60 may include interconnected nodes and/or vertices 62. Vertices 62 may be disposed at locations where mapping electrodes 24 are positioned. In at least some embodiments, the mesh 60 may take the form of a coarse triangular mesh. Creating a coarse triangular mesh may include approximating the geometry and/or the shape of a three-dimensional structure such as the three dimensional arrangement of mapping
25 electrodes 24. For example, a coarse triangular mesh may be designed to approximate the shape and physical relationships between electrodes 24 disposed on the basket structure 20 of a constellation catheter and/or similar sensing device deployed within a cardiac chamber of the heart. A triangular mesh may include a set of triangles that are drawn between the electrodes 24. Further, the three-dimensional
30 configuration may include flat faces and straight edges and/or lines that connect electrodes 24 together by their common edges or corners. The corners of the triangular faces may be defined as vertices 62.

In at least some embodiments, it may be desirable to further refine or "upsample" mesh 60. Figure 6 illustrates a schematic upsampled mesh 64. The upsampled mesh

64 may include interconnected nodes and/or vertices 62. The upsampled mesh 64 may be generated from a course triangular mesh. Upsampling may include subdividing the triangles of the triangular mesh into additional triangles. The additional triangles may include flat faces and straight edges and/or straight lines
5 connecting vertices 62 of the triangles.

The upsampled mesh 64 may be utilized to calculate the shortest distance between electrodes. For example, after the shortest distance between electrodes is calculated, the upsampled mesh 64 may be utilized to calculate the geodesic distances between electrodes. The geodesic distances may be substituted for the linear distance
10 in an example interpolation method. For example, the geodesic distance between two electrodes may be substituted for the linear distance between the electrodes in RBF, Kriging or similar interpolation methods. Using geodesic distance estimations instead of linear distance approximations or assumptions may provide a more accurate estimate of the interpolated data points.

15 In at least some embodiments, one or more interpolation methods stated above may be incorporated, included, utilized, and/or integrated into processing system 32. Processing system 32 may be configured such that the interpolation method may be implemented to populate and/or fill in electrodes 24 having missing data on activation map 72. Further, processing system 32 may incorporate an "iterative" process to
20 assess, populate and/or fill in electrodes 24 having missing data on activation map 72. The iterative process may cycle through determining an electrode 24 that has missing data, utilizing an interpolation method to estimate missing and/or inaccurate data and populating and/or filling in the missing data on the corresponding activation map 72. The processing system 32 may integrate and/or employ a feedback loop in the
25 iterative process. For example, the processing system 32 may integrate and/or employ a feedback loop when interpolating, choosing, and/or assigning activation times and populating and/or filling in activation map 72. A feedback loop may be designed to permit an operator (e.g. physician, clinician) to select the number of iterations processing system 32 will implement to populate activation map 72. For example, a
30 user (e.g. physician, clinician) may be able to input the number of iterations that processing system 32 will implement to populate activation map 72. It is further contemplated that processing system 32 may include a preset maximum number of iterations that it will implement when populating activation map 72.

The disclosed embodiments heretofore have focused on populating and/or estimating unknown and/or inaccurate data in an activation map. However, it is contemplated that the above methodologies may be utilized to estimate unknown and/or inaccurate data as it relates to any diagnostic display, data set, diagnostic visual representation, or the like. For example, the above methodologies may be utilized to estimate unknown and/or inaccurate data for a vector field map, isochronal map, or the like.

In at least some of the embodiments described above the disclosed methods assume analysis of sensed, collected, measured and transmitted electrical cellular data occurring during a single heartbeat and/or cardiac pulse. However, it is contemplated that any of the disclosed methods may be implemented across multiple beats or cardiac pacing time intervals. Further, data collected over multiple heartbeats may be analyzed using statistical methodologies and applied to the disclosed methods. For example, activation times may be collected over a series of heart beats and/or pulses. A statistical distribution of the collected activation times may be calculated, analyzed and incorporated into disclosed methods.

As described above, a variety of interpolation methods may be utilized to estimate missing or inaccurate data needed to populate and/or fill in diagnostic displays (e.g. an activation time map, vector field map, etc.). In general, interpolating inaccurate or missing data consists of inputting real-valued data (hereafter referred to as "known data" for simplicity) sensed by electrodes into an interpolation method, the output of which may be an estimated real value of the missing and/or inaccurate electrode data (hereafter referred to as "unknown data"). For purposes of this disclosure, it will be assumed that every electrode may have a known three-dimensional position in space. Further, it may be assumed that up to 63 of 64 electrodes (i.e. all electrodes but the unknown electrode) may have a known data value. For example, for a constellation catheter or similar sensing device, 64 of the 64 electrodes present on basket structure may have a known position in three-dimensional space and up to 63 of 64 may have a known data value. For example, electrodes may sense local activation times, and therefore, 63 of the 64 electrodes may have known activation times which may be utilized by an interpolation method.

In practice, it may be that electrodes in close proximity to one another will experience similar cellular events. For example, as a cellular activation wavefront propagates across an atrial surface, electrodes in close proximity to one another

will likely have similar cellular activation times. Therefore, when selecting an interpolation method, it may be desirable to select a method which incorporates the relative distance between neighboring electrodes and utilizes those distances in an algorithm to estimate unknown data points (e.g. estimate unknown activation times).

5 Radial Basis Function (RBF) interpolation is an example methodology that uses relative distance between electrodes to analytically estimate the value of unknown data.

In some embodiments, it may be desirable to utilize a RBF as an interpolation methodology because, in general, its output values may depend on the relative
10 distance of known values from the origin, or center of an unknown value. For purposes of this disclosure, the origin or center of an unknown value may correspond to unknown or missing electrode data. Therefore, a RBF may be utilized to interpolate unknown electrode data from surrounding, known electrode data. Further, the output of a RBF for each known electrode may be summed in order to incorporate
15 the input of all known data points when interpolating an unknown data point. For example, a RBF may utilize the known data of up to 63 mapping electrodes when interpolating the value of an unknown data point. Example RBF's may include Gaussian, Multiquadric, Inverse Quadric and/or Polyharmonic Spline. These are only examples. It is contemplated that the methodology described herein may be
20 applicable to any suitable RBF type.

In addition to incorporating the relative distance of neighboring electrodes into an interpolation method, it may also be desirable to "weigh" the contribution of those electrodes based on their distance from the unknown electrode. For example, it also may be desirable to "favor" the contribution of known data from electrodes close to
25 an unknown electrode, and "penalize" or "limit" the contributions of known data from electrodes which are farther away from an unknown electrode. This preferential weighting of known electrode data may be performed by RBF interpolation though the incorporation of a "weighting coefficient."

For the purposes of this disclosure, weighting coefficients are statistically,
30 mathematically and/or computationally derived values that are used to emphasize the contribution of one input parameter over another. For example, a known value (e.g. activation time) of a neighboring electrode in close proximity to an unknown value may be emphasized to a greater degree than a distant electrode when performing an interpolation methodology. Determining the weighting coefficients for a particular

set of known input values may be generated by using a weighting "kernel." A weighting kernel may be a real-valued function used in statistical estimation techniques. The weighting kernel real-valued function may provide a given output value for a given input value. Example kernel functions may include uniform, 5 triangular, tricube and Gaussian. These are just examples. It is contemplated that many different kernel functions may be utilized to generate weighting coefficients.

As stated above, it is likely that electrodes 24 in close proximity to one another will experience similar cellular events. Therefore, it may be desirable to choose a weighting kernel that emphasizes, or favors, input data from neighboring 10 electrodes and de-emphasizes input data from distant electrodes. Generating weighting coefficients that reflect this weighting scheme may be accomplished by utilizing a Gaussian kernel. Figure 7 shows an example schematic Gaussian weighting kernel. The Gaussian kernel may be represented by the equation:

15 Weighting Coefficient = $e^{(-0.5 * r * r / (d^2))}$; where

r = geodesic distance from unknown data point to a known data point

d = average geodesic distance from unknown data point to all known data points

20 As illustrated in Figure 7, the input values for the Gaussian kernel is the geodesic distance from the unknown data point to a known data point. In this example, input values lie on the X-axis and may be labeled "geodesic distance." The center value "0" may represent the location of an unknown electrode. As indicated, values on the X-axis increase to the left and right of the center point "0." The 25 increasing values may represent the geodesic distance of a known electrode from the center point of the unknown electrode. For example, a value of "2" may represent a geodesic distance of "2" units from the center of an unknown electrode to a known electrode. Geodesic distance is one example of an input variable contemplated by the embodiments disclosed herein. Other input values are contemplated for use with any 30 of the methods disclosed herein.

In some embodiments it may be desirable to further "condition" the kernel to more accurately reflect the desired weighting of the input neighboring electrodes. Conditioning the kernel may include modifying the input variables of the kernel. For

example, in the above weighting coefficient equation, the input variable "d" may represent the average geodesic distance from unknown data point to all known data points. Conditioning that kernel may include dividing the variable "d" in half. Figure 8 illustrates a schematic "conditioned" Gaussian weighting kernel of Figure 7. As illustrated in Figure 8, the weighting coefficient scale is different as compared to Figure 7. The "conditioned" Gaussian kernel may be represented by the equation:

$$\text{Weighting Coefficient} = e^{(-0.5 * r * r / (d/2)^2)}; \text{ where}$$

r = geodesic distance from unknown data point to a known data point

d = average geodesic distance from unknown data point to all known data points

As indicated above, the output value of the Gaussian kernel may be a weighting coefficient. For example, as illustrated by the dashed line 80 on Figure 8, an input value of r = 2 (e.g. r = geodesic distance) may represent an output value (i.e. weighting coefficient) of approximately 0.95. Weighting coefficients may be calculated for every known electrode. For example, weighting coefficients may be calculated for 63 of the 64 known electrode points mapped by a constellation catheter or similar sensing device. Further, the weighting coefficient may be incorporated into an interpolation methodology (e.g. RBF interpolation). The output of the interpolation methodology may provide that the estimation of an unknown electrode value based on a weighting and/or conditioned input of known electrode data.

While interpolation methods are useful and can provide a clinician with a reasonable approximation of unknown data, the confidence level of the interpolation may be unknown. Furthermore, the confidence of interpolated data may not be readily apparent or communicated to a clinician during an intervention. In other words, a clinician may not be aware of whether or not interpolated data is likely to be accurate when performing an intervention. The methods and devices disclosed herein are designed to help a clinician by determining and/or providing a confidence level for interpolated data.

In at least some instances, the confidence of interpolated data may be considered to be higher when the values for the interpolated data are based on data collected by electrodes positioned relatively close to electrodes with unknown data. As the distance between electrodes sensing/collecting unknown data and electrodes

sensing/collecting known data increases, the confidence level may drop when interpolating the unknown data. Thus, the distance between electrodes may be one factor that may be used when assessing the confidence of interpolated data.

Figure 9 illustrates an example probability distance matrix. The probability distance matrix may use distance between electrodes as the basis for the confidence of interpolated data. In this example, a number of electrodes that sense/collect known data (e.g., in this example the known data is used to determine a known activation time) are listed along the Y-axis and a number of electrodes with unknown data are listed along the X-axis. The activation times at electrodes with unknown data may be determined using an interpolation method such as those disclosed herein. When the interpolated values are determined using data from a number of electrodes that are positioned relatively close to the electrodes with unknown data, the confidence may be considered relatively high. Conversely, when the interpolated values are determined using data from a number of electrodes that are positioned further away from the electrodes with unknown data, the confidence may be considered lower. The probability matrix may be used to represent whether or not interpolated data based on electrodes with "known" data (e.g., activation times) is based on electrodes relatively close or relatively far away from the electrodes with "unknown" data. From this, the confidence level (e.g., the likelihood that that interpolated data is a good approximation for the actual activation time) for the interpolated data can be assessed and/or quantified.

It should be noted that Figure 9 is shown schematically and in gray scale. The gray scale may make it challenging to convey all of the various gradations between the confidence levels. In practice, colors, patterns, numbers, or the like may be used to convey the confidence level in an efficient manner.

Figure 10 illustrates an example graphical display 182 that utilizes confidence levels. Display 182 may include a plurality of panels such as a first panel 184, a second panel 186, and a third panel 188. In this example, first panel 184 may take the form of an activation map. The activation map may display activation times determined at electrodes 24. For example, a known activation time is shown in box 190 and a value is displayed in box 190 that represent the actual activation time. Another box 192 in the activation map displays a "?", which is meant to convey that the activation time is "unknown" for that particular electrode 24.

Second panel 186 may take the form of an interpolated activation map. In the interpolated activation map, an interpolation method such as those disclosed herein is utilized to determine activation times for the unknown data and the values are displayed in the interpolated activation map. For example, box 192, which displayed a "?" in the activation map in first panel 184, now displays a value representing an activation time in second panel 186.

In order to convey the confidence of the interpolated data, third panel 188 may take the form of a confidence map. Here, the confidence level of the interpolated data may be displayed. For example, a block of data 194 is highlighted with a bold outline in panels 184/186/188. The highlighting is provided for convenience and may or may not be utilized in display 182. In first panel 184, block 194 contains box 190 with a known activation time and additional boxes including box 192 with unknown activation times. In second panel 186, the known activation times are given a value using an interpolation method. Thus, within block 194, all the boxes include values representing activation times. In third panel 188, the confidence level of the interpolated data (as well as the "known" data is displayed. For example, the confidence level in box 190 is shown as "1". In other words, the confidence of the "known" data is considered to be 100% or 1. Other boxes with known activation times similarly show a confidence level of 1. The remaining boxes such as box 192 display a confidence level. For example, the confidence level in box 192 is shown as ".9" or 90%. It can be seen that the confidence level of the various boxes with interpolated data within block 194 vary. In at least some embodiments, the confidence level is determined based on the distance between the electrode with unknown data and the electrode(s) with known data that were used to interpolate the unknown data. As the distance between the electrodes with known data increases from the electrodes with unknown data, the confidence level decreases. The confidence level may help a clinician to more efficiently assess, diagnose, and/or treat a patient.

It should be noted that Figure 10 is shown schematically with numerical values and a corresponding numerical key (e.g., keys 189a/189b/189c). While the numerical values may be useful, in practice the data may utilize a color scheme, patterns, or the like to convey the information. As such, an appropriate key (e.g., a color-coded key) may be utilized. For example, panels 184/186/188 may include

color-coded boxes and keys 189a/189b/189c may provide values that correspond to the various colors shown in panels 184/186/188.

It should be understood that this disclosure is, in many respects, only illustrative. Changes may be made in details, particularly in matters of shape, size, and arrangement of steps without exceeding the scope of the invention. This may
5 include, to the extent that it is appropriate, the use of any of the features of one example embodiment being used in other embodiments. The invention's scope is, of course, defined in the language in which the appended claims are expressed.

What is claimed is:

1. A medical device, comprising:
a catheter shaft with a plurality of electrodes coupled thereto; and
a processor coupled to the catheter shaft, wherein the processor is capable of:
collecting a set of signals from the plurality of electrodes,
generating a data set from at least one of the set of signals,
wherein the data set includes at least one known data point and one or more unknown data points,
interpolating at least one of the unknown data points by conditioning the data set,
assigning an interpolated value to at least one of the unknown data points, and
assigning a confidence level to the interpolated value.
2. The medical device of claim 1, wherein collecting the set of signals includes determining an activation time at one or more of the plurality of electrodes.
3. The medical device of claim 2, wherein assigning a value to at least one of the unknown data points includes assigning an activation time to at least one of the unknown data points.
4. The medical device of claim 2, wherein determining the activation time includes identifying a fiducial point corresponding to a change in electrical potential and determining a time latency between a reference point and the fiducial point.
5. The medical device of any one of claims 1-4, wherein interpolating at least one of the unknown data points by conditioning the data set includes creating a mesh of interconnected nodes between the known data points, the unknown data points, or both the known and unknown data points.
6. The medical device of claim 5, wherein interpolating at least one of the unknown data points by conditioning the data set includes upsampling the mesh of interconnected nodes.

7. The medical device of any one of claims 1-6, wherein interpolating at least one of the unknown data points by conditioning the data set includes utilizing a non-linear distance between the known data points, unknown data points, or both the known and unknown data points.

8. The medical device of any one of claims 1-7, wherein interpolating at least one of the unknown data points by conditioning the data set includes utilizing a geodesic distance between the known data points, unknown data points, or both the known and unknown data points.

9. The medical device of any one of claims 1-8, wherein interpolating at least one of the unknown data points by conditioning the data set includes weighting the known data points and wherein weighting the known data points includes determining weighting coefficients from a weighting function.

10. The medical device of any one of claims 1-9, wherein the processor is capable of:

generating a graphical display of at least one known data point, one or more unknown data points or both; and

wherein the graphical display includes an activation map.

11. The medical device of claim 10, wherein the graphical display further comprises an interpolated activation map.

12. The medical device of claim 11, wherein the graphical display further comprises a confidence map representing the confidence level.

13. A method for displaying cardiac mapping data, the method comprising:
storing a set of activation times on a memory;

wherein the set of activation times includes one or more known activation times and one or more unknown activation times;

outputting the set of activation times to a display unit;

displaying the activation times on a first panel of the display unit;

interpolating the unknown activation times;

displaying the interpolated activation times on a second panel of the display unit;

displaying a confidence map on a third panel of the display unit; and
wherein the confidence map displays the level of confidence for the interpolated activation times.

14. A medical device, comprising:

a catheter shaft with a plurality of electrodes coupled thereto; and

a processor coupled to the catheter shaft, wherein the processor is capable of:

sensing electrical activity with the plurality of electrodes,

determining activation times at the plurality of electrodes based on the sensed electrical activity,

wherein determining activation times at the plurality of electrodes includes determining one or more known activation times and one or more unknown activation times,

interpolating the one or more unknown activation times,

assigning an interpolated activation time to each of the one or more unknown activation times, and

assigning a confidence level to the interpolated activation times.

15. The medical device of claim 14, wherein the processor is capable of:

generating a graphical display;

wherein the graphical display includes an activation map, an interpolated activation map, and a confidence map representing the confidence level of the interpolated activation times.

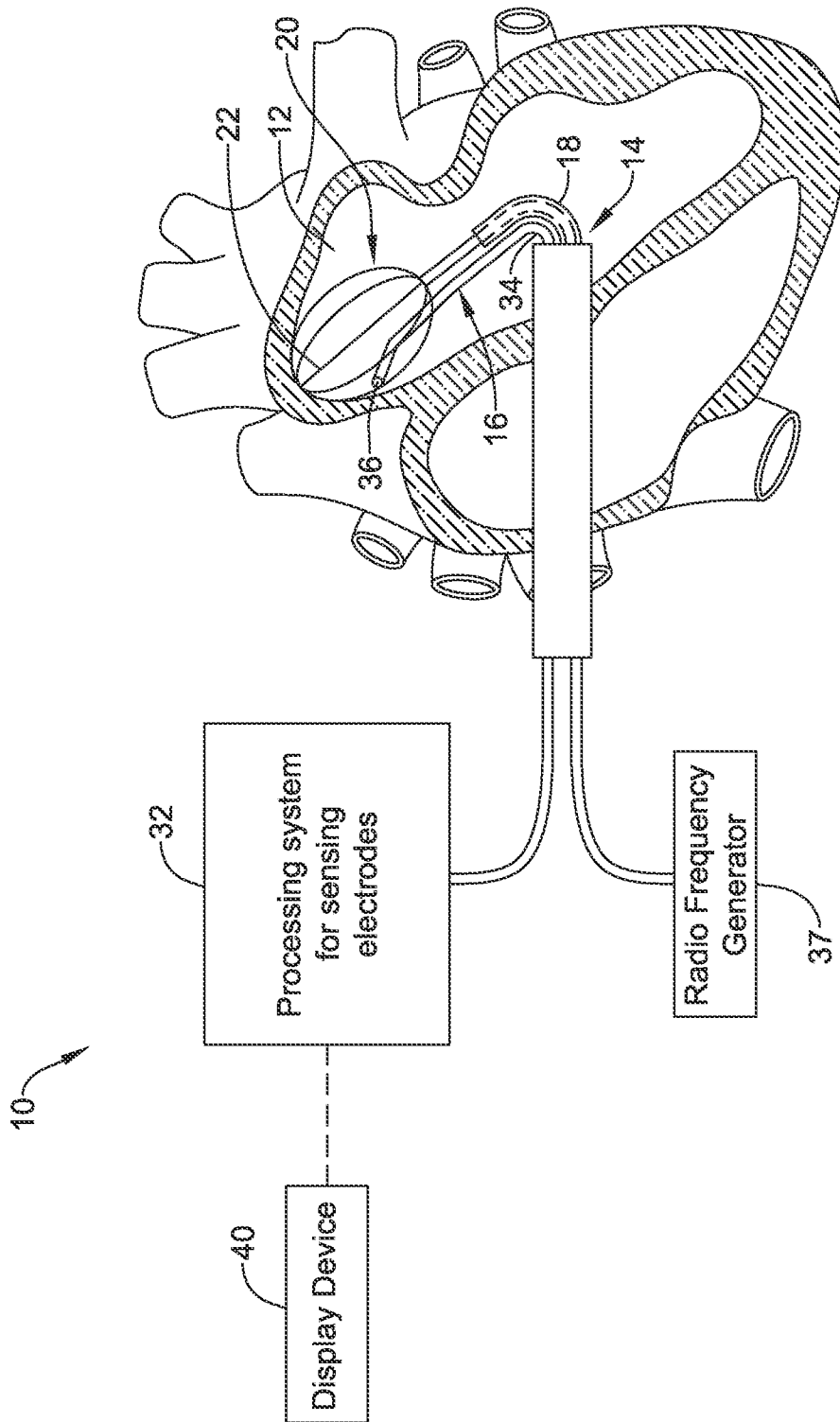

FIG. 1

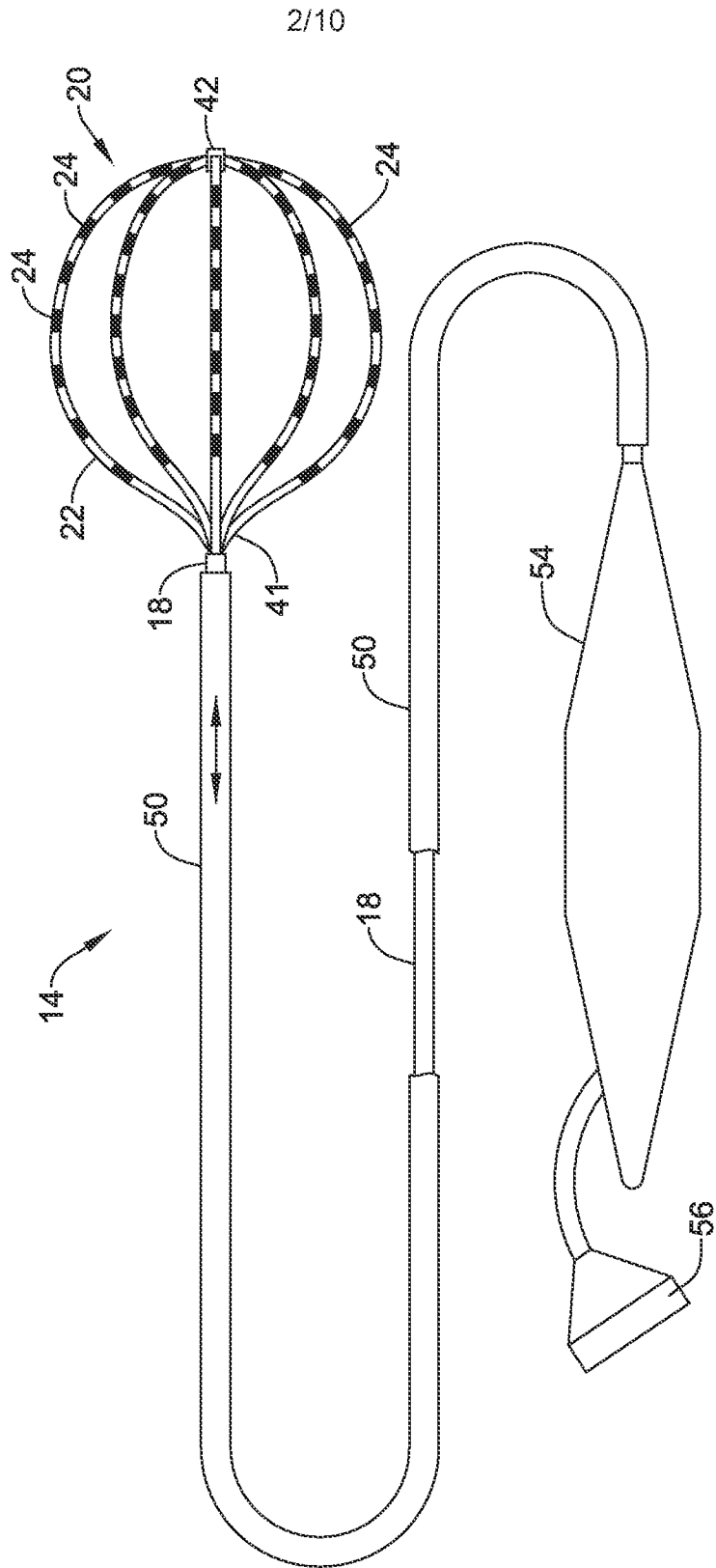

FIG. 2

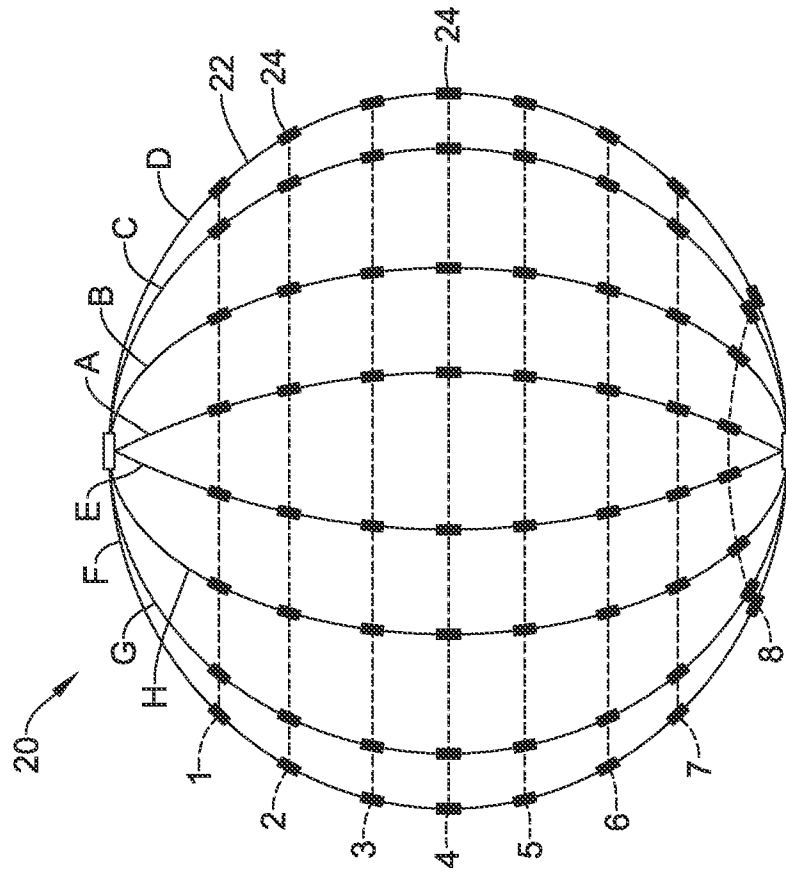

FIG. 3

72

71

70

0.101	0.105	0.113	0.126	0.135	0.143	0.154	?
0.084	?	?	?	?	?	?	?
0.070	?	?	?	?	?	?	0.000
0.084	0.072	0.050	0.038	0.042	0.046	0.046	0.044
0.073	0.069	0.069	?	0.061	0.056	0.056	0.060
0.092	0.086	?	?	?	?	?	?
0.112	?	?	?	?	?	?	?
0.109	0.112	0.163	0.162	0.162	0.181	0.181	0.179

A B C D E F G H

Struts

Electrodes

1 2 3 4 5 6 7 8

FIG. 4

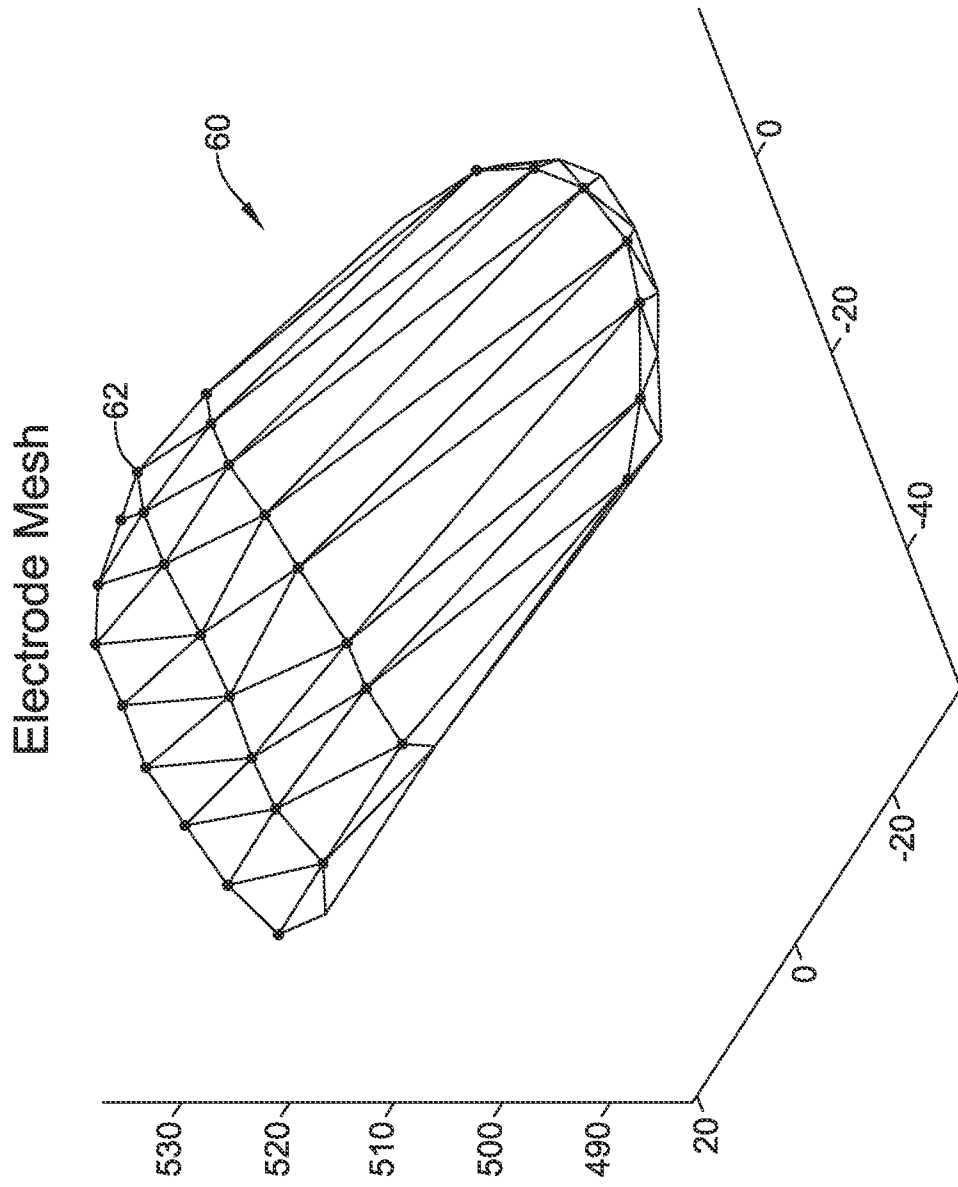

FIG. 5

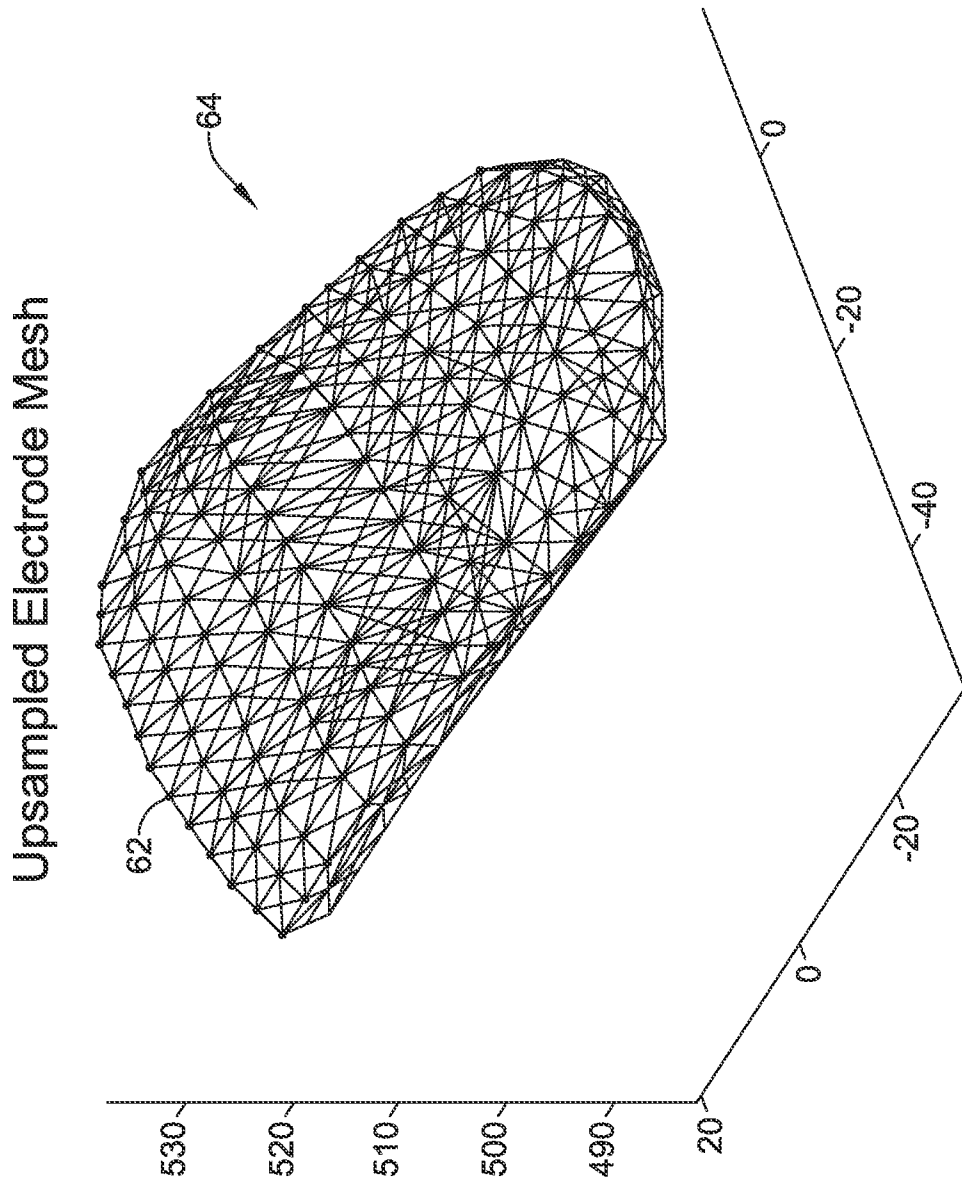

FIG. 6

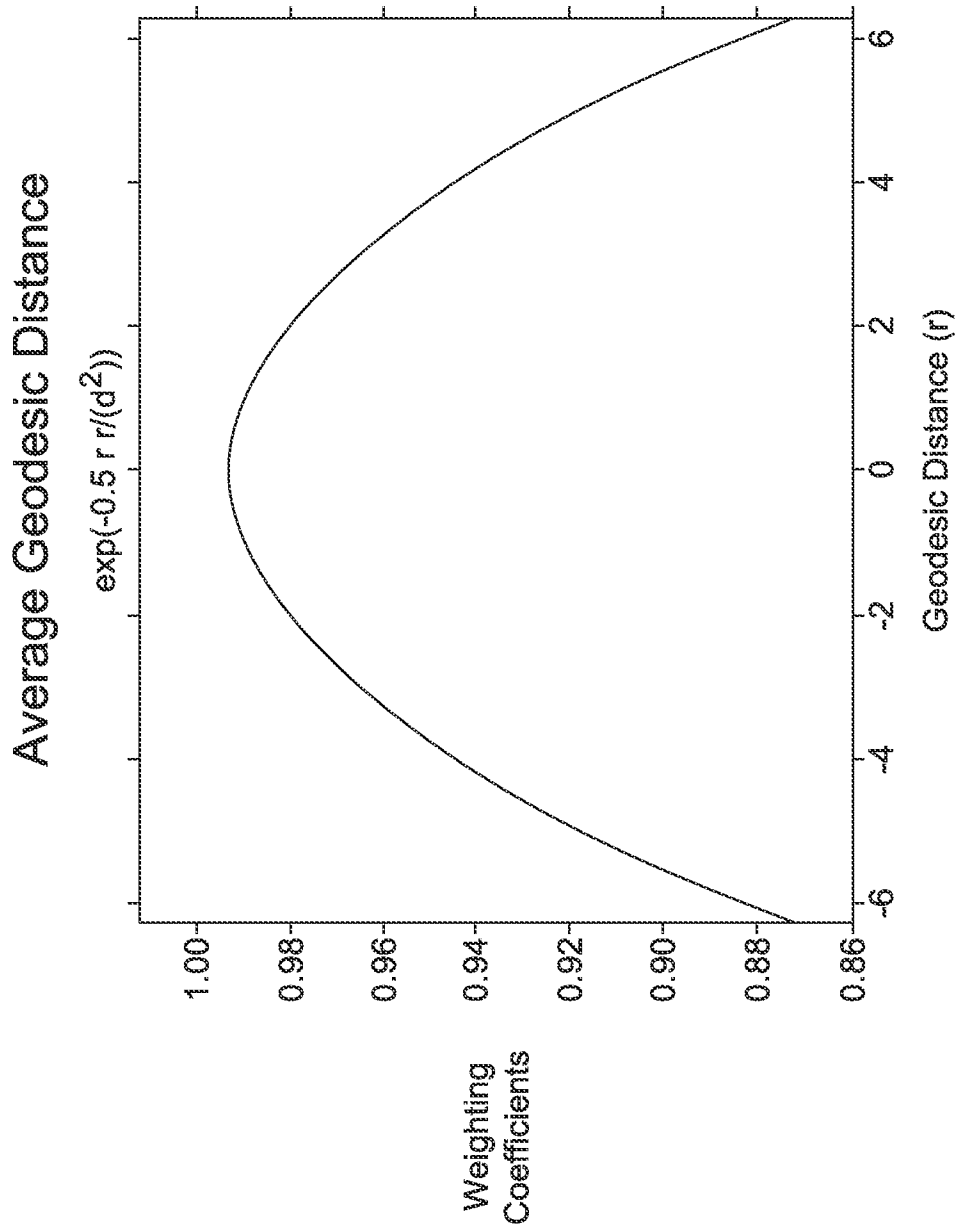

FIG. 7

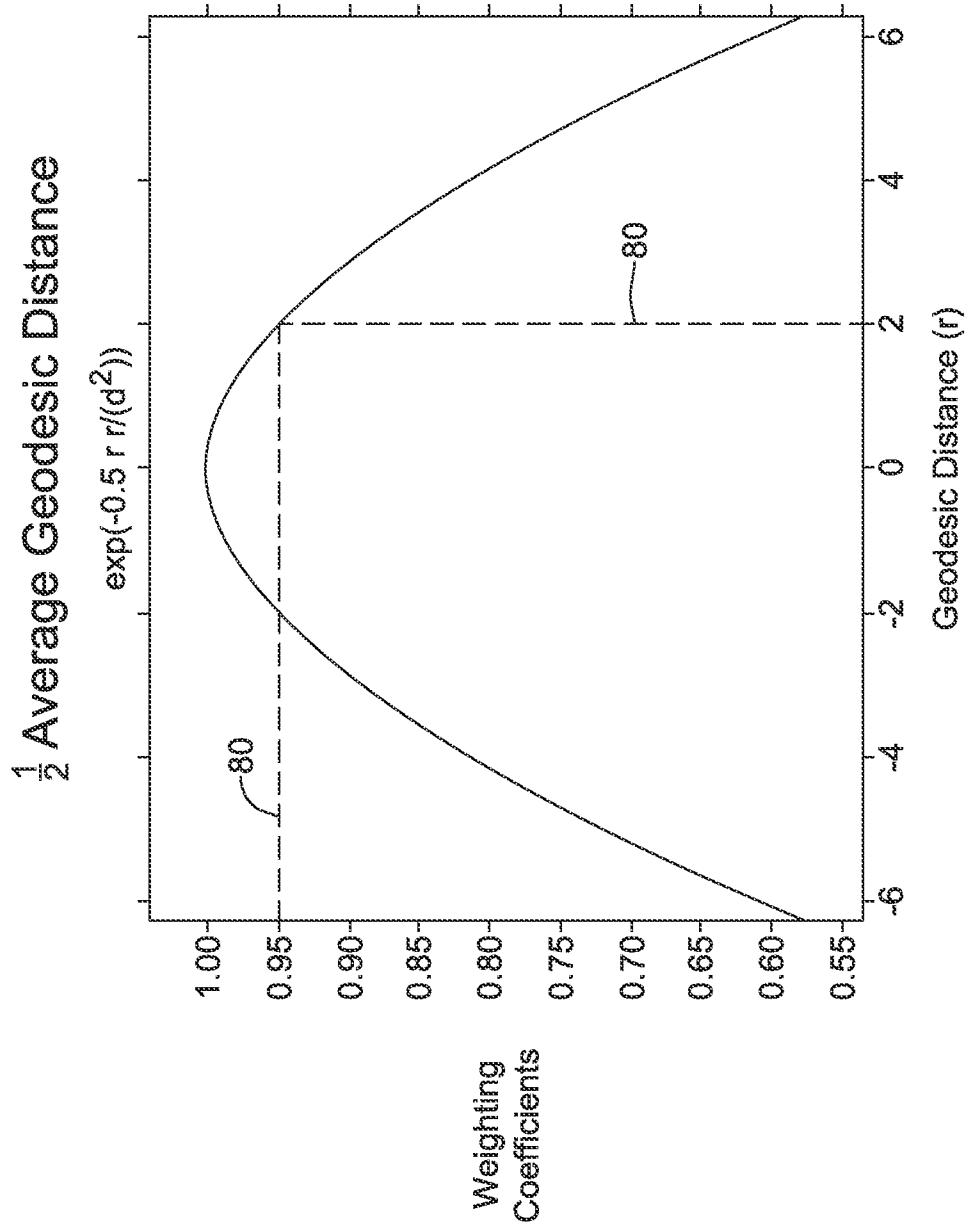
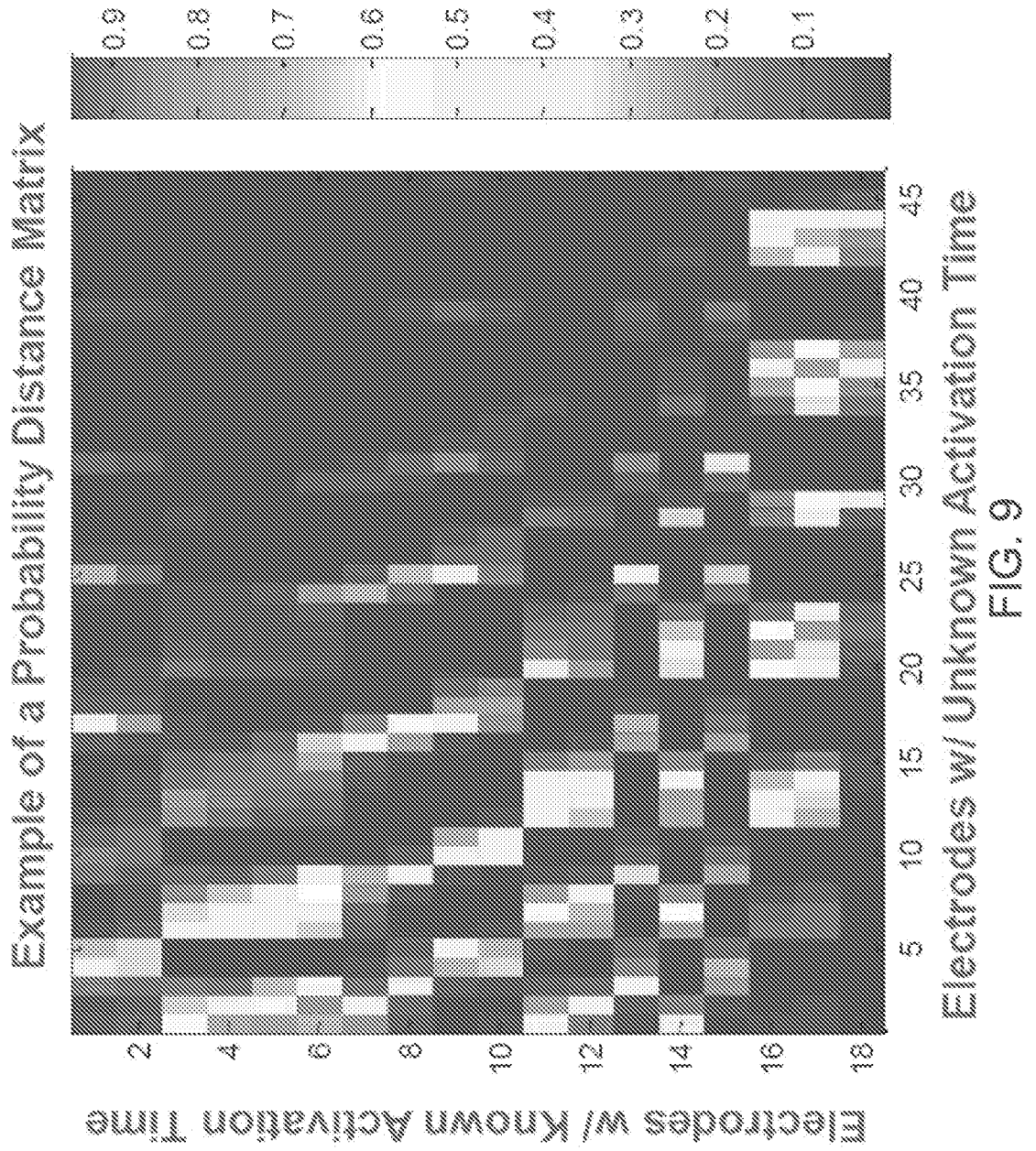

FIG. 8



Electrodes w/ Unknown Activation Time

FIG. 9

INTERNATIONAL SEARCH REPORT

International application No
PCT/US2015/017775

A. CLASSIFICATION OF SUBJECT MATTER
INV. A61B5/00 A61B5/0452
 ADD.
 According to International Patent Classification (IPC) or to both national classification and IPC

B. FIELDS SEARCHED
 Minimum documentation searched (classification system followed by classification symbols)
A61B

Documentation searched other than minimum documentation to the extent that such documents are included in the fields searched

Electronic data base consulted during the international search (name of data base and, where practicable, search terms used)
EPO-Internal , WPI Data, PAJ

C. DOCUMENTS CONSIDERED TO BE RELEVANT

Category*	Citation of document, with indication, where appropriate, of the relevant passages	Relevant to claim No.
X	US 5 876 336 A (SWANSON DAVID K [US] ET AL) 2 March 1999 (1999-03-02) col umn 18, line 33 - line 46 -----	1-15
X	US 2012/265054 AI (OLSON ERIC S [US]) 18 October 2012 (2012-10-18) abstract paragraph [0027] - paragraph [0055] ----- -/- .	1-15

Further documents are listed in the continuation of Box C.

See patent family annex.

* Special categories of cited documents :

- "A" document defining the general state of the art which is not considered to be of particular relevance
- "E" earlier application or patent but published on or after the international filing date
- "L" document which may throw doubts on priority claim(s) or which is cited to establish the publication date of another citation or other special reason (as specified)
- "O" document referring to an oral disclosure, use, exhibition or other means
- "P" document published prior to the international filing date but later than the priority date claimed

- "T" later document published after the international filing date or priority date and not in conflict with the application but cited to understand the principle or theory underlying the invention
- "X" document of particular relevance; the claimed invention cannot be considered novel or cannot be considered to involve an inventive step when the document is taken alone
- "Y" document of particular relevance; the claimed invention cannot be considered to involve an inventive step when the document is combined with one or more other such documents, such combination being obvious to a person skilled in the art
- "&" document member of the same patent family

Date of the actual completion of the international search 18 May 2015	Date of mailing of the international search report 26/05/2015
Name and mailing address of the ISA/ European Patent Office, P.B. 5818 Patentlaan 2 NL - 2280 HV Rijswijk Tel. (+31-70) 340-2040, Fax: (+31-70) 340-3016	Authorized officer Van Dop, Eri k

INTERNATIONAL SEARCH REPORT

International application No
PCT/US2015/017775

C(Continuation). DOCUMENTS CONSIDERED TO BE RELEVANT		
Category*	Citation of document, with indication, where appropriate, of the relevant passages	Relevant to claim No.
X	<p>Ugur CLinedi ogl u ET AL: "Usage of spline interpolation in catheter-based cardiac mapping", Turkish Journal of Electrical Engineering and Computer Sciences, 1 January 2010 (2010-01-01), pages 989-1002, XP055095999, DOI: 10.3906/el k-0911-277 Retrieved from the Internet: URL: http://journal.s.tubitak.gov.tr/elektrik/issues/el k-10-18-6/el k-18-6-5-0911-277.pdf [retrieved on 2015-03-25] paragraph [0001] - paragraph [0002]</p> <p>-----</p>	1-15
X	<p>US 2010/274150 A1 (HARLEV DORON [US] ET AL) 28 October 2010 (2010-10-28) the whole document</p> <p>-----</p>	1-15
X	<p>WO 2011/021948 A1 (AUCKLAND UNISERVICES LTD [NZ]; O'GRADY GREGORY BRIAN [NZ]; CHENG LEO K) 24 February 2011 (2011-02-24) page 20, line 17 - line 23</p> <p>-----</p>	1-15

INTERNATIONAL SEARCH REPORT

Information on patent family members

International application No

PCT/US2015/017775

Patent document cited in search report	Publication date	Patent family member(s)	Publication date
US 5876336	A	02-03-1999	US 5876336 A 02-03-1999
			US 6070094 A 30-05-2000
			US 6353751 B1 05-03-2002
			US 6456864 B1 24-09-2002

US 2012265054	AI	18-10-2012	AU 2012243268 AI 03-10-2013
			CA 2830740 AI 18-10-2012
			CN 103687533 A 26-03-2014
			EP 2675347 AI 25-12-2013
			JP 5661974 B2 28-01-2015
			JP 2014511737 A 19-05-2014
			US 2012265054 AI 18-10-2012
			Wo 2012141775 AI 18-10-2012

US 2010274150	AI	28-10-2010	CA 2758611 AI 28-10-2010
			EP 2421432 A2 29-02-2012
			JP 5703288 B2 15-04-2015
			JP 2012524606 A 18-10-2012
			US 2010274150 AI 28-10-2010
			US 2011275949 AI 10-11-2011
			wo 2010123637 A2 28-10-2010

Wo 2011021948	AI	24-02-2011	AU 2010284772 AI 08-03-2012
			EP 2467055 AI 27-06-2012
			US 2013035576 AI 07-02-2013
			wo 2011021948 AI 24-02-2011

专利名称(译)	用于绘制心脏组织的医疗设备		
公开(公告)号	EP3113671A1	公开(公告)日	2017-01-11
申请号	EP2015708426	申请日	2015-02-26
[标]申请(专利权)人(译)	波士顿科学西美德公司		
申请(专利权)人(译)	BOSTON SCIENTIFIC SCIMED , INC.		
当前申请(专利权)人(译)	BOSTON SCIENTIFIC SCIMED , INC.		
[标]发明人	LAUGHNER JACOB I SHOME SHIBAJI MEYER SCOTT A		
发明人	LAUGHNER, JACOB I. SHOME, SHIBAJI MEYER, SCOTT A.		
IPC分类号	A61B5/00 A61B5/0452		
CPC分类号	A61B5/04012 A61B5/0422 A61B5/044 A61B5/0452 A61B5/6859		
优先权	61/949625 2014-03-07 US		
外部链接	Espacenet		

摘要(译)

公开了用于制造和使用医疗装置的医疗装置和方法。示范性医疗装置可包括导管轴，其具有与其连接的多个电极，以及连接到导管轴的处理单元。处理器能够从多个电极收集一组信号，并从该组信号中的至少一个产生数据集。数据集可以包括至少一个已知数据点和一个或多个未知数据点。处理器还能够通过调节数据集来内插至少一个未知数据点，将内插值分配给至少一个未知数据点，并将置信水平分配给内插值。