



- (51) **International Patent Classification:**
A61B 5/05 (2006.01)
- (21) **International Application Number:**
PCT/US20 14/0220 19
- (22) **International Filing Date:**
7 March 2014 (07.03.2014)
- (25) **Filing Language:** English
- (26) **Publication Language:** English
- (30) **Priority Data:**
61/775,397 8 March 2013 (08.03.2013) US
- (71) **Applicant: C.R. BARD, INC.** [US/US]; 730 Central Avenue, Murray Hill, NJ 07974 (US).
- (72) **Inventor: MISENER, Anthony, Kent;** 289 East 400 South, Bountiful, UT 84010 (US).
- (74) **Agent: WIGHT, Todd, W.;** Rutan & Tucker LLP, 611 Anton Boulevard, Suite 1400, Costa Mesa, CA 92626 (US).
- (81) **Designated States** (*unless otherwise indicated, for every kind of national protection available*): AE, AG, AL, AM, AO, AT, AU, AZ, BA, BB, BG, BH, BN, BR, BW, BY,

BZ, CA, CH, CL, CN, CO, CR, CU, CZ, DE, DK, DM, DO, DZ, EC, EE, EG, ES, FI, GB, GD, GE, GH, GM, GT, HN, HR, HU, ID, IL, IN, IR, IS, JP, KE, KG, KN, KP, KR, KZ, LA, LC, LK, LR, LS, LT, LU, LY, MA, MD, ME, MG, MK, MN, MW, MX, MY, MZ, NA, NG, NI, NO, NZ, OM, PA, PE, PG, PH, PL, PT, QA, RO, RS, RU, RW, SA, SC, SD, SE, SG, SK, SL, SM, ST, SV, SY, TH, TJ, TM, TN, TR, TT, TZ, UA, UG, US, UZ, VC, VN, ZA, ZM, ZW.

(84) **Designated States** (*unless otherwise indicated, for every kind of regional protection available*): ARIPO (BW, GH, GM, KE, LR, LS, MW, MZ, NA, RW, SD, SL, SZ, TZ, UG, ZM, ZW), Eurasian (AM, AZ, BY, KG, KZ, RU, TJ, TM), European (AL, AT, BE, BG, CH, CY, CZ, DE, DK, EE, ES, FI, FR, GB, GR, HR, HU, IE, IS, IT, LT, LU, LV, MC, MK, MT, NL, NO, PL, PT, RO, RS, SE, SI, SK, SM, TR), OAPI (BF, BJ, CF, CG, CI, CM, GA, GN, GQ, GW, KM, ML, MR, NE, SN, TD, TG).

Declarations under Rule 4.17:

— *f* inventorship (Rule 4.17(iv))

Published:

— *with international search report (Art. 21(3))*



WO 2014/138652 A1

(54) **Title: ICONIC REPRESENTATIONS RELATING TO SYSTEMS FOR PLACING A MEDICAL DEVICE**

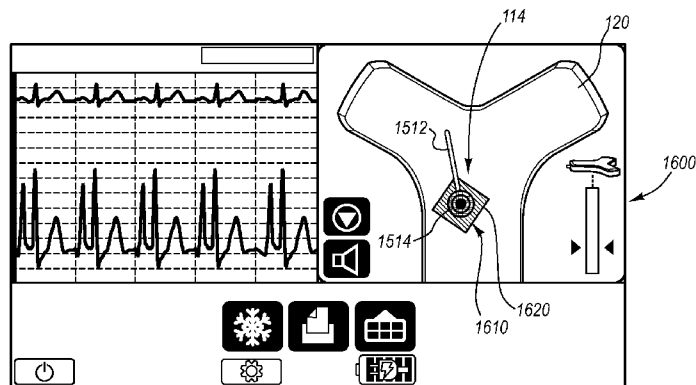

FIG. 74

(57) **Abstract:** An integrated catheter placement system for accurately placing a catheter within a patient's vasculature is disclosed. In one embodiment, the integrated system comprises a system console, a tip location sensor for temporary placement on the patient's chest, and an ultrasound probe. The tip location sensor senses a magnetic field of a stylet disposed in a lumen of the catheter when the catheter is disposed in the vasculature. The ultrasound probe ultrasonically images a portion of the vasculature prior to introduction of the catheter. ECG signal-based catheter tip guidance is included in the integrated system to enable guidance of the catheter tip to a desired position with respect to a node of the patient's heart. Iconic representations for depiction on the display of the system and relating to positional and other characteristics of the catheter or medical device are also disclosed.

**ICONIC REPRESENTATIONS RELATING TO
SYSTEMS FOR PLACING A MEDICAL DEVICE**

CROSS-REFERENCE TO RELATED APPLICATIONS

[0001] This application claims the benefit of U.S. Provisional Patent Application No. 61/775,397, filed March 8, 2013, and titled "Iconic Representations for Guidance of an Indwelling Medical Device," which is incorporated herein by reference in its entirety.

BRIEF SUMMARY

[0002] Briefly summarized, embodiments of the present invention are directed to an integrated catheter placement system configured for accurately placing a catheter within the vasculature of a patient. The integrated system employs at least two modalities for improving catheter placement accuracy: 1) ultrasound-assisted guidance for introducing the catheter into the patient's vasculature; and 2) a tip location system ("TLS"), or magnetically-based (*e.g.*, via permanent magnet(s) or electromagnet(s)) tracking of the catheter tip during its advancement through the vasculature to detect and facilitate correction of any tip malposition during such advancement.

[0003] In one embodiment, the integrated system comprises a system console including a control processor, a tip location sensor for temporary placement on a portion of a body of the patient, and an ultrasound probe. The tip location sensor senses a magnetic field of a stylet disposed in a lumen of the catheter when the catheter is disposed in the vasculature. The ultrasound probe ultrasonically images a portion of the vasculature prior to introduction of the catheter into the vasculature. In addition, the ultrasound probe includes user input controls for controlling use of the ultrasound probe in an ultrasound mode and use of the tip location sensor in a tip location mode.

[0004] In another embodiment, a third modality, *i.e.*, ECG signal-based catheter tip guidance, is included in the system to enable guidance of the catheter tip to a desired position with respect to a node of the patient's heart from which the ECG signals originate. Various means for establishing a conductive pathway between a sterile field of the patient and a non-sterile field to enable passage of ECG signals from the catheter to the tip location sensor are also disclosed. Such means include, for example, connector schemes that establish the conductive pathway through a perforation defined in a sterile barrier, such as a surgical drape,

wherein the perforation is isolated by the connector scheme so as to prevent contamination or compromise of the sterile field of the patient.

[0005] In further embodiments, various aspects for visualizing and manipulating display of the ECG signal data acquired via the present catheter placement system are disclosed. These display aspects enable a clinician placing the catheter or other invasive medical device to ascertain information relating to the proximity of the device relative to the ECG signal-emitting node. In yet other embodiments, aspects of various ECG sensor configurations are also disclosed. In further embodiments, iconic representations for depiction on the display of the system and relating to positional and other characteristics of the catheter or medical device are also disclosed.

[0006] These and other features of embodiments of the present invention will become more fully apparent from the following description and appended claims, or may be learned by the practice of embodiments of the invention as set forth hereinafter.

BRIEF DESCRIPTION OF THE DRAWINGS

[0007] A more particular description of the present disclosure will be rendered by reference to specific embodiments thereof that are illustrated in the appended drawings. It is appreciated that these drawings depict only typical embodiments of the invention and are therefore not to be considered limiting of its scope. Example embodiments of the invention will be described and explained with additional specificity and detail through the use of the accompanying drawings in which:

[0008] FIG. 1 is a block diagram depicting various elements of an integrated system for intravascular placement of a catheter, according to one example embodiment of the present invention;

[0009] FIG. 2 is a simplified view of a patient and a catheter being inserted therein with assistance of the integrated system of FIG. 1;

[00010] FIGS. 3A and 3B are views of a probe of the integrated system of FIG. 1;

[00011] FIG. 4 is a screenshot of an ultrasound image as depicted on a display of the integrated system of FIG. 1;

[00012] FIG. 5 is a perspective view of a stylet employed in connection with the system of FIG. 1 in placing a catheter within a patient vasculature;

[00013] FIG. 6 is an icon as depicted on a display of the integrated system of FIG. 1, indicating a position of a distal end of the stylet of FIG. 5 during catheter tip placement procedures;

[00014] FIGS. 7A-7E depict various example icons that can be depicted on the display of the integrated system of FIG. 1 during catheter tip placement procedures;

[00015] FIGS. 8A-8C are screenshots of images depicted on a display of the integrated system of FIG. 1 during catheter tip placement procedures;

[00016] FIG. 9 is a block diagram depicting various elements of an integrated system for intravascular placement of a catheter, according to another example embodiment of the present invention;

[00017] FIG. 10 is a simplified view of a patient and a catheter being inserted therein with assistance of the integrated system of FIG. 9;

[00018] FIG. 11 is a perspective view of a stylet employed in connection with the integrated system of FIG. 9 in placing a catheter within a patient vasculature;

[00019] FIGS. 12A-12E are various views of portions of the stylet of FIG. 11;

[00020] FIGS. 13A-13D are various views of a fin connector assembly for use with the integrated system of FIG. 9;

[00021] FIGS. 13E-13F are various views of a tether connector for use with the fin connector assembly shown in FIGS. 13A-13D;

[00022] FIGS. 14A-14C are views showing the connection of a stylet tether and fin connector to a sensor of the integrated system of FIG. 9;

[00023] FIG. 15 is a cross sectional view of the connection of the stylet tether, fin connector, and sensor shown in FIG. 14C;

[00024] FIG. 16 is simplified view of an ECG trace of a patient;

[00025] FIG. 17 is a screenshot of an image depicted on a display of the integrated system of FIG. 9 during catheter tip placement procedures;

[00026] FIG. 18 is a cross sectional view of a fin connector including electrical contacts configured in accordance with one embodiment;

[00027] FIGS. 19A and 19B are simplified views of an electrical contact retention system for engagement of a tether connector with a fin connector, in accordance with one embodiment;

[00028] FIGS. 20A-20C are various views of one embodiment of a fin connector and a tether connector for establishing a signal pathway through a sterile barrier in connection with use of the integrated system described herein;

[00029] FIGS. 21A and 21B are various views of a connector for electrically connecting ECG electrodes to a sensor of the integrated system, according to one embodiment;

[00030] FIGS. 22A-22C are various views of one embodiment of a fin connector and a tether connector for establishing a signal pathway through a sterile barrier;

[00031] FIGS. 23A and 23B are cross sectional views of a connector system for establishing a signal pathway through a sterile barrier, according to one embodiment;

[00032] FIG. 24 is a simplified side view of a connector system for establishing a signal pathway through a sterile barrier, according to one embodiment;

[00033] FIGS. 25A and 25B are simplified side views of a connector system for establishing a signal pathway through a sterile barrier, according to one embodiment;

[00034] FIGS. 26A and 26B are cross sectional views of a connector system for establishing a signal pathway through a sterile barrier, according to one embodiment;

[00035] FIG. 27 is a simplified view of a connector system for establishing a signal pathway through a sterile barrier, according to one embodiment;

[00036] FIG. 28 is a perspective view of stylet including a sterile shield for use with the connector system shown in FIG. 28, according to one embodiment;

[00037] FIGS. 29A and 29B are simplified views of the ECG module of FIG. 27, including a connector system for establishing a signal pathway through a sterile barrier, according to one embodiment;

[00038] FIG. 30 is a simplified view of a connector system for establishing a signal pathway through a sterile barrier, according to one embodiment;

[00039] FIG. 31 is a simplified view of a connector system for establishing a signal pathway through a sterile barrier, according to one embodiment;

[00040] FIG. 32 is a simplified view of elements of a connector system for establishing a signal pathway through a sterile barrier, according to one embodiment;

[00041] FIG. 33 is a view of a means for establishing a conductive pathway between sterile and non-sterile fields, according to one embodiment;

[00042] FIG. 34 is a view of another means for establishing a conductive pathway between sterile and non-sterile fields, according to one embodiment;

[00043] FIGS. 35A-C depict exemplary P-wave waveforms;

[00044] FIG. 36 is a view of a sensor retro-fitted with a wireless module, according to one embodiment;

[00045] FIG. 37 is a view of a retention feature for a connector, according to one embodiment;

[00046] FIG. 38 is a perspective view of a catheter including an ECG sensor according to one embodiment;

[00047] FIG. 39 is a perspective view of a sensor assembly including multiple electrodes disposed on a catheter;

[00048] FIGS. 40A-40C depict operation of the catheter of FIG. 39;

[00049] FIGS. 41A-41D are various views of an electrode connection integrity indicator and system in accordance with one embodiment;

[00050] FIGS. 42 is a perspective view of an electrode connection integrity system according to one embodiment;

[00051] FIGS. 43A and 43B are cross sectional views of a stylet including a conductive wire loop for detecting severing of the stylet according to one embodiment;

[00052] FIG. 44 is a partial cross sectional view the stylet of FIG. 43A, including a conductive wire loop with a planar wire in accordance with one embodiment;

[00053] FIG. 45 is a cross sectional view of a catheter including a stylet with a distal interference feature according to one embodiment;

[00054] FIG. 46 is a cross sectional view of a catheter including a stylet with a distal interference feature according to another embodiment;

[00055] FIGS. 47A and 47B are cross sectional views of distal portions of a catheter and stylet configured to maintain alignment of the distal ends of the catheter and stylet according to one embodiment.

[00056] FIG. 48 is a perspective view of an external dual-ECG electrode assembly in accordance with one embodiment;

[00057] FIG. 49 is a perspective view of an external ECG electrode assembly including graphics in accordance with one embodiment;

[00058] FIG. 50 is an ECG trace showing P-wave characteristics according to one embodiment;

[00059] FIG. 51 is a flow chart describing one method according to one embodiment;

[00060] FIGS. 52-55 are ECG traces showing additional P-wave characteristics according to embodiments of the present disclosure;

[00061] FIGS. 56A-57B are ECG traces showing details regarding ECG waveform scaling according to one embodiment;

[00062] FIG. 58 is a flow chart describing one method according to one embodiment;

[00063] FIG. 59 is a display window including aspects of a single ECG waveform according to one embodiment;

[00064] FIG. 60 is a flow chart describing one method according to one embodiment;

[00065] FIG. 61 is a catheter placement record configured according to one embodiment;

[00066] FIG. 62 is another catheter placement record configured according to one embodiment;

[00067] FIG. 63 is a block diagram depicting various elements of an integrated system for intravascular placement of a catheter as one example environment where embodiments of the present invention can be practiced;

[00068] FIG. 64 is a simplified view of a patient and a catheter being inserted therein with assistance of the integrated system of FIG. 63;

[00069] FIG. 65 shows various icons for depiction on the display of the integrated system of FIG. 63, indicating a four-dimensional position and orientation of a distal end of a stylet associated with the catheter of FIG. 64 during catheter tip placement procedures;

[00070] FIG. 66 shows a simplified flow chart of a method for determining and depicting the icons of FIG. 65, according to one embodiment;

[00071] FIGS. 67A-67F depict various example icons that can be depicted on the display of the integrated system of FIG. 63 during catheter tip placement procedures to indicate a four-dimensional position and orientation of the distal end of a stylet associated with the catheter of FIG. 64;

[00072] FIGS. 68A and 68B show an example icon for depiction on the display of the integrated system of FIG. 63, indicating a five-dimensional position and orientation of the distal end of a stylet associated with the catheter of FIG. 64 during catheter tip placement procedures;

[00073] FIG. 69 shows an example icon for depiction on the display of the integrated system of FIG. 63, indicating a six-dimensional position and orientation of a distal end of the stylet associated with the catheter of FIG. 64 during catheter tip placement procedures;

[00074] FIG. 70 shows further possible icons including multi-dimensional information according to one embodiment;

[00075] FIG. 71 shows further possible icons including multi-dimensional information according to one embodiment;

[00076] FIG. 72 shows further possible icons including multi-dimensional information according to one embodiment;

[00077] FIG. 73 shows a screenshot with one example of an icon indicating information relating to a position of an indwelling device according to one embodiment;

[00078] FIG. 74 shows a screenshot with one example of an icon indicating information relating to a position of an indwelling device according to one embodiment; and

[00079] FIG. 75 shows a screenshot with one example of an icon indicating information relating to a position of an indwelling device according to one embodiment.

DETAILED DESCRIPTION OF SELECTED EMBODIMENTS

[00080] Reference will now be made to figures wherein like structures will be provided with like reference designations. It is understood that the drawings are diagrammatic and schematic representations of exemplary embodiments of the present invention, and are neither limiting nor necessarily drawn to scale.

[00081] Embodiments of the present invention are generally directed to a catheter placement system configured for accurately placing a catheter within the vasculature of a patient. In one embodiment, the catheter placement system employs at least two modalities for improving catheter placement accuracy: 1) ultrasound-assisted guidance for introducing the catheter into the patient's vasculature; and 2) a tip location/navigation system ("TLS"), or magnetically-based tracking of the catheter tip during its advancement through the tortuous vasculature path to detect and facilitate correction of any tip malposition during such advancement. The ultrasound guidance and tip location features of the present system according to one embodiment are integrated into a single device for use by a clinician placing the catheter. Integration of these two modalities into a single device simplifies the catheter placement process and results in relatively faster catheter placements. For instance, the integrated catheter placement system enables ultrasound and TLS activities to be viewed

from a single display of the integrated system. Also, controls located on an ultrasound probe of the integrated device, which probe is maintained within the sterile field of the patient during catheter placement, can be used to control functionality of the system, thus precluding the need for a clinician to reach out of the sterile field in order to control the system.

[00082] In another embodiment, a third modality, *i.e.*, ECG signal-based catheter tip guidance, is included in the integrated system to enable guidance of the catheter tip to a desired position with respect to a node of the patient's heart from which the ECG signals originate. Such ECG-based positional assistance is also referred to herein as "tip confirmation."

[00083] Combination of the three modalities above according to one embodiment enables the catheter placement system to facilitate catheter placement within the patient's vasculature with a relatively high level of accuracy, *i.e.*, placement of the distal tip of the catheter in a predetermined and desired position. Moreover, because of the ECG-based guidance of the catheter tip, correct tip placement may be confirmed without the need for a confirmatory X-ray. This, in turn, reduces the patient's exposure to potentially harmful x-rays, the cost and time involved in transporting the patient to and from the x-ray department, costly and inconvenient catheter repositioning procedures, etc.

[00084] As the ECG signal-based modality includes a need for passing ECG signals from a catheter assembly disposed in a sterile field of a patient to a data-receiving component of the system disposed in a non-sterile field, embodiments of the present invention are further concerned with various connector systems for establishing a conductive pathway through a sterile barrier separating the sterile and non-sterile fields. Various aspects for visualizing and manipulating display of the ECG signal data acquired via the present system, together with aspects of various ECG sensor configurations, are also disclosed. Example iconic representations relating to the system's detection of the indwelling catheter or other medical device are also disclosed.

[00085] For clarity it is to be understood that the word "proximal" as used herein refers to a direction relatively closer to a clinician, while the word "distal" refers to a direction relatively further from the clinician. For example, the end of a catheter placed within the body of a patient is considered a distal end of the catheter, while the catheter end remaining outside the body is a proximal end of the catheter. Also, the words "including," "has," and

"having," as used herein, including the claims, shall have the same meaning as the word "comprising."

[00086] Reference is first made to FIGS. 1 and 2 which depict various components of a catheter placement system ("system"), generally designated at 10, configured in accordance with one example embodiment of the present invention. As shown, the system 10 generally includes a console 20, display 30, probe 40, and sensor 50, each of which is described in further detail below.

[00087] FIG. 2 shows the general relation of these components to a patient 70 during a procedure to place a catheter 72 into the patient vasculature through a skin insertion site 73. FIG. 2 shows that the catheter 72 generally includes a proximal portion 74 that remains exterior to the patient and a distal portion 76 that resides within the patient vasculature after placement is complete. The system 10 is employed to ultimately position a distal tip 76A of the catheter 72 in a desired position within the patient vasculature. In one embodiment, the desired position for the catheter distal tip 76A is proximate the patient's heart, such as in the lower one-third ($1/3^{\text{rd}}$) portion of the Superior Vena Cava ("SVC"). Of course, the system 10 can be employed to place the catheter distal tip in other locations. The catheter proximal portion 74 further includes a hub 74A that provides fluid communication between the one or more lumens of the catheter 72 and one or more extension legs 74B extending proximally from the hub.

[00088] An example implementation of the console 20 is shown in FIG. 8C, though it is appreciated that the console can take one of a variety of forms. A processor 22, including non-volatile memory such as EEPROM for instance, is included in the console 20 for controlling system function during operation of the system 10, thus acting as a control processor. A digital controller/analog interface 24 is also included with the console 20 and is in communication with both the processor 22 and other system components to govern interfacing between the probe 40, sensor 50, and other system components.

[00089] The system 10 further includes ports 52 for connection with the sensor 50 and optional components 54 including a printer, storage media, keyboard, etc. The ports in one embodiment are USB ports, though other port types or a combination of port types can be used for this and the other interfaces connections described herein. A power connection 56 is included with the console 20 to enable operable connection to an external power supply 58.

An internal battery 60 can also be employed, either with or exclusive of an external power supply. Power management circuitry 59 is included with the digital controller/analog interface 24 of the console to regulate power use and distribution.

[00090] The display 30 in the present embodiment is integrated into the console 20 and is used to display information to the clinician during the catheter placement procedure. In another embodiment, the display may be separate from the console. As will be seen, the content depicted by the display 30 changes according to which mode the catheter placement system is in: US, TLS, or in other embodiments, ECG tip confirmation. In one embodiment, a console button interface 32 (*see* FIGS. 1, 8C) and buttons included on the probe 40 can be used to immediately call up a desired mode to the display 30 by the clinician to assist in the placement procedure. In one embodiment, information from multiple modes, such as TLS and ECG, may be displayed simultaneously, such as in FIG. 17. Thus, the single display 30 of the system console 20 can be employed for ultrasound guidance in accessing a patient's vasculature, TLS guidance during catheter advancement through the vasculature, and (as in later embodiments) ECG-based confirmation of catheter distal tip placement with respect to a node of the patient's heart. In one embodiment, the display 30 is an LCD device.

[00091] FIGS. 3A and 3B depict features of the probe 40 according to one embodiment. The probe 40 is employed in connection with the first modality mentioned above, *i.e.*, ultrasound ("US")-based visualization of a vessel, such as a vein, in preparation for insertion of the catheter 72 into the vasculature. Such visualization gives real time ultrasound guidance for introducing the catheter into the vasculature of the patient and assists in reducing complications typically associated with such introduction, including inadvertent arterial puncture, hematoma, pneumothorax, etc.

[00092] The handheld probe 40 includes a head 80 that houses a piezoelectric array for producing ultrasonic pulses and for receiving echoes thereof after reflection by the patient's body when the head is placed against the patient's skin proximate the prospective insertion site 73 (FIG. 2). The probe 40 further includes a plurality of control buttons 84, which can be included on a button pad 82. In the present embodiment, the modality of the system 10 can be controlled by the control buttons 84, thus eliminating the need for the clinician to reach out of the sterile field, which is established about the patient insertion site prior to catheter placement, to change modes via use of the console button interface 32.

[00093] As such, in one embodiment a clinician employs the first (US) modality to determine a suitable insertion site and establish vascular access, such as with a needle or introducer, then with the catheter. The clinician can then seamlessly switch, via button pushes on the probe button pad 82, to the second (TLS) modality without having to reach out of the sterile field. The TLS mode can then be used to assist in advancement of the catheter 72 through the vasculature toward an intended destination.

[00094] FIG. 1 shows that the probe 40 further includes button and memory controller 42 for governing button and probe operation. The button and memory controller 42 can include non-volatile memory, such as EEPROM, in one embodiment. The button and memory controller 42 is in operable communication with a probe interface 44 of the console 20, which includes a piezo input/output component 44A for interfacing with the probe piezoelectric array and a button and memory input/output component 44B for interfacing with the button and memory controller 42.

[00095] FIG. 4 shows an example screenshot 88 as depicted on the display 30 while the system 10 is in its first ultrasound modality. An image 90 of a subcutaneous region of the patient 70 is shown, depicting a cross section of a vein 92. The image 90 is produced by operation of the piezoelectric array of the probe 40. Also included on the display screenshot 88 is a depth scale indicator 94, providing information regarding the depth of the image 90 below the patient's skin, a lumen size scale 96 that provides information as to the size of the vein 92 relative to standard catheter lumen sizes, and other indicia 98 that provide information regarding status of the system 10 or possible actions to be taken, *e.g.*, freeze frame, image templates, data save, image print, power status, image brightness, etc.

[00096] Note that while a vein is depicted in the image 90, other body lumens or portions can be imaged in other embodiments. Note that the US mode shown in FIG. 4 can be simultaneously depicted on the display 30 with other modes, such as the TLS mode, if desired. In addition to the visual display 30, aural information, such as beeps, tones, etc., can also be employed by the system 10 to assist the clinician during catheter placement. Moreover, the buttons included on the probe 40 and the console button interface 32 can be configured in a variety of ways, including the use of user input controls in addition to buttons, such as slide switches, toggle switches, electronic or touch-sensitive pads, etc. Additionally, both US and TLS activities can occur simultaneously or exclusively during use of the system 10.

[00097] As just described, the handheld ultrasound probe 40 is employed as part of the integrated catheter placement system 10 to enable US visualization of the peripheral vasculature of a patient in preparation for transcutaneous introduction of the catheter. In the present example embodiment, however, the probe is also employed to control functionality of the TLS portion, or second modality, of the system 10 when navigating the catheter toward its desired destination within the vasculature as described below. Again, as the probe 40 is used within the sterile field of the patient, this feature enables TLS functionality to be controlled entirely from within the sterile field. Thus the probe 40 is a dual-purpose device, enabling convenient control of both US and TLS functionality of the system 10 from the sterile field. In one embodiment, the probe can also be employed to control some or all ECG-related functionality, or third modality, of the catheter placement system 10, as described further below.

[00098] The catheter placement system 10 further includes the second modality mentioned above, *i.e.*, the magnetically-based catheter TLS, or tip location system. The TLS enables the clinician to quickly locate and confirm the position and/or orientation of the catheter 72, such as a peripherally-inserted central catheter ("PICC"), central venous catheter ("CVC"), or other suitable catheter, during initial placement into and advancement through the vasculature of the patient 70. Specifically, the TLS modality detects a magnetic field generated by a magnetic element-equipped tip location stylet, which is pre-loaded in one embodiment into a longitudinally defined lumen of the catheter 72, thus enabling the clinician to ascertain the general location and orientation of the catheter tip within the patient body. In one embodiment, the magnetic assembly can be tracked using the teachings of one or more of the following U.S. patents: 5,775,322; 5,879,297; 6,129,668; 6,216,028; and 6,263,230. The contents of the afore-mentioned U.S. patents are incorporated herein by reference in their entireties. The TLS also displays the direction in which the catheter tip is pointing, thus further assisting accurate catheter placement. The TLS further assists the clinician in determining when a malposition of the catheter tip has occurred, such as in the case where the tip has deviated from a desired venous path into another vein.

[00099] As mentioned, the TLS utilizes a stylet to enable the distal end of the catheter 72 to be tracked during its advancement through the vasculature. FIG. 5 gives an example of such a stylet 100, which includes a proximal end 100A and a distal end 100B. A handle is included at the stylet proximal end 100A, with a core wire 104 extending distally therefrom.

A magnetic assembly is disposed distally of the core wire 104. The magnetic assembly includes one or more magnetic elements 106 disposed adjacent one another proximate the stylet distal end 100B and encapsulated by tubing 108. In the present embodiment, a plurality of magnetic elements 106 is included, each element including a solid, cylindrically shaped ferromagnetic stacked end-to-end with the other magnetic elements. An adhesive tip 110 can fill the distal tip of the tubing 108, distally to the magnetic elements 106.

[000100] Note that in other embodiments, the magnetic elements may vary from the design in not only shape, but also composition, number, size, magnetic type, and position in the stylet distal segment. For example, in one embodiment, the plurality of ferromagnetic magnetic elements is replaced with an electromagnetic assembly, such as an electromagnetic coil, which produces a magnetic field for detection by the sensor. Another example of an assembly usable here can be found in U.S. Patent No. 5,099,845 titled "Medical Instrument Location Means," which is incorporated herein by reference in its entirety. Yet other examples of stylets including magnetic elements that can be employed with the TLS modality can be found in U.S. Publication No. 2007/0049846 titled "Stylet Apparatuses and Methods of Manufacture," which is incorporated herein by reference in its entirety. These and other variations are therefore contemplated by embodiments of the present invention. It should be appreciated herein that "stylet" as used herein can include any one of a variety of devices configured for removable placement within a lumen of the catheter to assist in placing a distal end of the catheter in a desired location within the patient's vasculature.

[000101] FIG. 2 shows disposal of the stylet 100 substantially within a lumen in the catheter 72 such that the proximal portion thereof extends proximally from the catheter lumen, through the hub 74A and out through a selected one of the extension legs 74B. So disposed within a lumen of the catheter, the distal end 100B of the stylet 100 is substantially co-terminal with the distal catheter end 76A such that detection by the TLS of the stylet distal end correspondingly indicates the location of the catheter distal end.

[000102] The TLS sensor 50 is employed by the system 10 during TLS operation to detect a magnetic field produced by the magnetic elements 106 of the stylet 100. As seen in FIG. 2, the TLS sensor 50 is placed on the chest of the patient during catheter insertion. The TLS sensor 50 is placed on the chest of the patient in a predetermined location, such as through the use of external body landmarks, to enable the magnetic field of the stylet magnetic elements 106, disposed in the catheter 72 as described above, to be detected during catheter transit

through the patient vasculature. Again, as the magnetic elements 106 of the stylet magnetic assembly are co-terminal with the distal end 76A of the catheter 72 (FIG. 2), detection by the TLS sensor 50 of the magnetic field of the magnetic elements provides information to the clinician as to the position and orientation of the catheter distal end during its transit.

[000103] In greater detail, the TLS sensor 50 is operably connected to the console 20 of the system 10 via one or more of the ports 52, as shown in FIG. 1. Note that other connection schemes between the TLS sensor and the system console can also be used without limitation. As just described, the magnetic elements 106 are employed in the stylet 100 to enable the position of the catheter distal end 76A (FIG. 2) to be observable relative to the TLS sensor 50 placed on the patient's chest. Detection by the TLS sensor 50 of the stylet magnetic elements 106 is graphically displayed on the display 30 of the console 20 during TLS mode. In this way, a clinician placing the catheter is able to generally determine the location of the catheter distal end 76A within the patient vasculature relative to the TLS sensor 50 and detect when catheter malposition, such as advancement of the catheter along an undesired vein, is occurring.

[000104] FIGS. 6 and 7A-7E show examples of icons that can be used by the console display 30 to depict detection of the stylet magnetic elements 106 by the TLS sensor 50. In particular, FIG. 6 shows an icon 114 that depicts the distal portion of the stylet 100, including the magnetic elements 106 as detected by the TLS sensor 50 when the magnetic elements are positioned under the TLS sensor. As the stylet distal end 100B is substantially co-terminal with the distal end 76A of the catheter 72, the icon indicates the position and orientation of the catheter distal end. FIGS. 7A-7E show various icons that can be depicted on the console display 30 when the magnetic elements 106 of the stylet 100 are not positioned directly under a portion of the TLS sensor 50, but are nonetheless detected nearby. The icons can include half-icons 114A and quarter-icons 114B that are displayed according to the position of the stylet magnetic assembly, *i.e.*, the magnetic elements 106 in the present embodiment, relative to the TLS sensor 50.

[000105] FIGS. 8A-8C depict screenshots taken from the display 30 of the system 10 while in TLS mode, showing how the magnetic assembly of the stylet 100 is depicted. The screenshot 118 of FIG. 8A shows a representative image 120 of the TLS sensor 50. Other information is provided on the display screenshot 118, including a depth scale indicator 124, status/action indicia 126, and icons 128 corresponding to the button interface 32 included on

the console 20 (FIG. 8C). Though the icons 128 in the present embodiment are simply indicators to guide the user in identifying the purpose of the corresponding buttons of the button interface 32, in another embodiment the display can be made touch-sensitive so that the icons themselves can function as button interfaces and can change according to the mode the system is in.

[000106] During initial stages of catheter advancement through the patient's vasculature after insertion therein, the distal end 76A of the catheter 72, having the stylet distal end 100B substantially co-terminal therewith, is relatively distant from the TLS sensor 50. As such, the display screenshot will indicate "no signal," indicating that the magnetic field from the stylet magnetic assembly has not been detected. In FIG. 8B, the magnetic assembly proximate the stylet distal end 100B has advanced sufficiently close to the TLS sensor 50 to be detected thereby, though it is not yet under the sensor. This is indicated by the half-icon 114A shown to the left of the sensor image 120, representing the stylet magnetic assembly being positioned to the right of the TLS sensor 50 from the perspective of the patient.

[000107] In FIG. 8C, the magnetic assembly proximate the stylet distal end 100B has advanced under the TLS sensor 50 such that its position and orientation relative thereto is detected by the TLS sensor. This is indicated by the icon 114 on the sensor image 120. Note that the button icons 128 provide indications of the actions that can be performed by pressing the corresponding buttons of the console button interface 32. As such, the button icons 128 can change according to which modality the system 10 is in, thus providing flexibility of use for the button interface 32. Note further that, as the button pad 82 of the probe 40 (FIG. 3A, 3B) includes buttons 84 that mimic several of the buttons of the button interface 32, the button icons 128 on the display 30 provide a guide to the clinician for controlling the system 10 with the probe buttons 84 while remaining in the sterile field. For instance, if the clinician has need to leave TLS mode and return to US (ultrasound) mode, the appropriate control button 84 on the probe button pad 82 can be depressed, and the US mode can be immediately called up, with the display 30 refreshing to accommodate the visual information needed for US functionality, such as that shown in FIG. 4. This is accomplished without a need for the clinician to reach out of the sterile field.

[000108] Reference is now made to FIGS. 9 and 10 in describing the integrated catheter placement system 10 according to another example embodiment. As before, the integrated system 10 includes the console 20, display 30, probe 40 for US functionality, and the TLS

sensor 50 for tip location functionality as described above. Note that the system 10 depicted in FIGS. 9 and 10 is similar in many respects to the system shown in FIGS. 1 and 2. As such, only selected differences will be discussed below. The system 10 of FIGS. 9 and 10 includes additional functionality wherein determination of the proximity of the catheter distal tip 76A relative to a sino-atrial ("SA") or other electrical impulse-emitting node of the heart of the patient 70 can be determined, thus providing enhanced ability to accurately place the catheter distal tip in a desired location proximate the node. Also referred to herein as "ECG" or "ECG-based tip confirmation," this third modality of the system 10 enables detection of ECG signals from the SA node in order to place the catheter distal tip in a desired location within the patient vasculature. Note that the US, TLS, and ECG modalities are seamlessly combined in the present system 10, but can be employed in concert or individually to assist in catheter placement. In one embodiment, it is understood that the ECG modality as described herein can be included in a stand-alone system without the inclusion of the US and TLS modalities. Thus, the environments in which the embodiments herein are described are understood as merely example environments and are not considered limiting of the present disclosure.

[000109] FIGS. 9 and 10 show the addition to the system 10 of a stylet 130 configured in accordance with the present embodiment. As an overview, the catheter stylet 130 is removably predisposed within the lumen of the catheter 72 being inserted into the patient 70 via the insertion site 73. The stylet 130, in addition to including a magnetic assembly for the magnetically-based TLS modality, includes a sensing component, *i.e.*, an ECG sensor assembly, proximate its distal end and including a portion that is co-terminal with the distal end of the catheter tip for sensing ECG signals produced by the SA node. In contrast to the previous embodiment, the stylet 130 includes a tether 134 extending from its proximal end that operably connects to the TLS sensor 50. As will be described in further detail, the stylet tether 134 permits ECG signals detected by the ECG sensor assembly included on a distal portion of the stylet 130 to be conveyed to the TLS sensor 50 during confirmation of the catheter tip location as part of the ECG signal-based tip confirmation modality. Reference and ground ECG lead/electrode pairs 158 attach to the body of the patient 70 and are operably attached to the TLS sensor 50 to enable the system to filter out high level electrical activity unrelated to the electrical activity of the SA node of the heart, thus enabling the ECG-based tip confirmation functionality. Together with the reference and ground signals received from the ECG lead/electrode pairs 158 placed on the patient's skin, the ECG

signals sensed by the stylet ECG sensor assembly are received by the TLS sensor 50 positioned on the patient's chest (FIG. 10) or other designated component of the system 10. The TLS sensor 50 and/or console processor 22 can process the ECG signal data to produce an electrocardiogram waveform on the display 30, as will be described. In the case where the TLS sensor 50 processes the ECG signal data, a processor is included therein to perform the intended functionality. If the console 20 processes the ECG signal data, the processor 22, controller 24, or other processor can be utilized in the console to process the data.

[000110] Thus, as it is advanced through the patient vasculature, the catheter 72 equipped with the stylet 130 as described above can advance under the TLS sensor 50, which is positioned on the chest of the patient as shown in FIG. 10. This enables the TLS sensor 50 to detect the position of the magnetic assembly of the stylet 130, which is substantially co-terminal with the distal tip 76A of the catheter as located within the patient's vasculature. The detection by the TLS sensor 50 of the stylet magnetic assembly is depicted on the display 30 during ECG mode. The display 30 further depicts during ECG mode an ECG electrocardiogram waveform produced as a result of patient heart's electrical activity as detected by the ECG sensor assembly of the stylet 130. In greater detail, the ECG electrical activity of the SA node, including the P-wave of the waveform, is detected by the ECG sensor assembly of the stylet (described below) and forwarded to the TLS sensor 50 and console 20. The ECG electrical activity is then processed for depiction on the display 30. A clinician placing the catheter can then observe the ECG data to determine optimum placement of the distal tip 76A of the catheter 72, such as proximate the SA node in one embodiment. In one embodiment, the console 20 includes the electronic components, such as the processor 22 (FIG. 9), necessary to receive and process the signals detected by the stylet ECG sensor assembly. In another embodiment, the TLS sensor 50 can include the necessary electronic components processing the ECG signals.

[000111] As already discussed, the display 30 is used to display information to the clinician during the catheter placement procedure. The content of the display 30 changes according to which mode the catheter placement system is in: US, TLS, or ECG. Any of the three modes can be immediately called up to the display 30 by the clinician, and in some cases information from multiple modes, such as TLS and ECG, may be displayed simultaneously. In one embodiment, as before, the mode the system is in may be controlled by the control buttons 84 included on the handheld probe 40, thus eliminating the need for the clinician to

reach out of the sterile field (such as touching the button interface 32 of the console 20) to change modes. Thus, in the present embodiment the probe 40 is employed to also control some or all ECG-related functionality of the system 10. Note that the button interface 32 or other input configurations can also be used to control system functionality. Also, in addition to the visual display 30, aural information, such as beeps, tones, etc., can also be employed by the system to assist the clinician during catheter placement.

[000112] Reference is now made to FIGS. 11-12E in describing various details of one embodiment of the stylet 130 that is removably loaded into the catheter 72 and employed during insertion to position the distal tip 76A of the catheter in a desired location within the patient vasculature. As shown, the stylet 130 as removed from the catheter defines a proximal end 130A and a distal end 130B. A connector 132 is included at the proximal stylet end 130A, and a tether 134 extends distally from the connector and attaches to a handle 136. A core wire 138 extends distally from the handle 136. The stylet 130 is pre-loaded within a lumen of the catheter 72 in one embodiment such that the distal end 130B is substantially flush, or co-terminal, with the catheter opening at the distal end 76A thereof (FIG. 10), and such that a proximal portion of the core wire 138, the handle 136, and the tether 134 extend proximally from a selected one of the extension tubes 74B. Note that, though described herein as a stylet, in other embodiments a guidewire or other catheter guiding apparatus could include the principles of the embodiment described herein.

[000113] The core wire 138 defines an elongate shape and is composed of a suitable stylet material including stainless steel or a memory material such as, in one embodiment, a nickel and titanium-containing alloy commonly known by the acronym "nitinol." Though not shown here, manufacture of the core wire 138 from nitinol in one embodiment enables the portion of the core wire corresponding to a distal segment of the stylet to have a pre-shaped bent configuration so as to urge the distal portion of the catheter 72 into a similar bent configuration. In other embodiments, the core wire includes no pre-shaping. Further, the nitinol construction lends torqueability to the core wire 138 to enable a distal segment of the stylet 130 to be manipulated while disposed within the lumen of the catheter 72, which in turn enables the distal portion of the catheter to be navigated through the vasculature during catheter insertion.

[000114] The handle 136 is provided to enable insertion/removal of the stylet from the catheter 72. In embodiments where the stylet core wire 138 is torqueable, the handle 136

further enables the core wire to be rotated within the lumen of the catheter 72, to assist in navigating the catheter distal portion through the vasculature of the patient 70.

[000115] The handle 136 attaches to a distal end of the tether 134. In the present embodiment, the tether 134 is a flexible, shielded cable housing one or more conductive wires electrically connected both to the core wire 138, which acts as the ECG sensor assembly referred to above, and the tether connector 132. As such, the tether 134 provides a conductive pathway from the distal portion of the core wire 138 through to the tether connector 132 at proximal end 130A of the stylet 130. As will be explained, the tether connector 132 is configured for operable connection to the TLS sensor 50 on the patient's chest for assisting in navigation of the catheter distal tip 76A to a desired location within the patient vasculature.

[000116] As seen in FIGS. 12B-12D, a distal portion of the core wire 138 is gradually tapered, or reduced in diameter, distally from a junction point 142. A sleeve 140 is slid over the reduced-diameter core wire portion. Though of relatively greater diameter here, the sleeve in another embodiment can be sized to substantially match the diameter of the proximal portion of the stylet core wire. The stylet 130 further includes a magnetic assembly disposed proximate the distal end 130B thereof for use during TLS mode. The magnetic assembly in the illustrated embodiment includes a plurality of magnetic elements 144 interposed between an outer surface of the reduced-diameter core wire 138 and an inner surface of the sleeve 140 proximate the stylet distal end 130B. In the present embodiment, the magnetic elements 144 include 20 ferromagnetic magnets of a solid cylindrical shape stacked end-to-end in a manner similar to the stylet 100 of FIG. 2. In other embodiments, however, the magnetic element(s) may vary from this design in not only shape, but also composition, number, size, magnetic type, and position in the stylet. For example, in one embodiment the plurality of magnets of the magnetic assembly is replaced with an electromagnetic coil that produces a magnetic field for detection by the TLS sensor. These and other variations are therefore contemplated by embodiments of the present invention.

[000117] The magnetic elements 144 are employed in the stylet 130 distal portion to enable the position of the stylet distal end 130B to be observable relative to the TLS sensor 50 placed on the patient's chest. As has been mentioned, the TLS sensor 50 is configured to detect the magnetic field of the magnetic elements 144 as the stylet advances with the catheter 72 through the patient vasculature. In this way, a clinician placing the catheter 72 is

able to generally determine the location of the catheter distal end 76A within the patient vasculature and detect when catheter malposition is occurring, such as advancement of the catheter along an undesired vein, for instance.

[000118] The stylet 130 further includes the afore-mentioned ECG sensor assembly, according to one embodiment. The ECG sensor assembly enables the stylet 130, disposed in a lumen of the catheter 72 during insertion, to be employed in detecting an intra-atrial ECG signal produced by an SA or other node of the patient's heart, thereby allowing for navigation of the distal tip 76A of the catheter 72 to a predetermined location within the vasculature proximate the patient's heart. Thus, the ECG sensor assembly serves as an aide in confirming proper placement of the catheter distal tip 76A.

[000119] In the embodiment illustrated in FIGS. 11-12E, the ECG sensor assembly includes a distal portion of the core wire 138 disposed proximate the stylet distal end 130B. The core wire 138, being electrically conductive, enables ECG signals to be detected by the distal end thereof and transmitted proximally along the core wire. A conductive material 146, such as a conductive epoxy, fills a distal portion of the sleeve 140 adjacent the distal termination of the core wire 138 so as to be in conductive communication with the distal end of the core wire. This in turn increases the conductive surface of the distal end 130B of the stylet 130 so as to improve its ability to detect ECG signals.

[000120] Before catheter placement, the stylet 130 is loaded into a lumen of the catheter 72. Note that the stylet 130 can come preloaded in the catheter lumen from the manufacturer, or loaded into the catheter by the clinician prior to catheter insertion. The stylet 130 is disposed within the catheter lumen such that the distal end 130B of the stylet 130 is substantially co-terminal with the distal tip 76A of the catheter 72, thus placing the distal tips of both the stylet and the catheter in substantial alignment with one another. The co-terminality of the catheter 72 and stylet 130 enables the magnetic assembly to function with the TLS sensor 50 in TLS mode to track the position of the catheter distal tip 76A as it advances within the patient vasculature, as has been described. Note, however, that for the tip confirmation functionality of the system 10, the distal end 130B of the stylet 130 need not be co-terminal with the catheter distal end 76A. Rather, all that is required is that a conductive path between the vasculature and the ECG sensor assembly, in this case the core wire 138, be established such that electrical impulses of the SA node or other node of the

patient's heart can be detected. This conductive path in one embodiment can include various components including saline solution, blood, etc.

[000121] In one embodiment, once the catheter 72 has been introduced into the patient vasculature via the insertion site 73 (FIG. 10) the TLS mode of the system 10 can be employed as already described to advance the catheter distal tip 76A toward its intended destination proximate the SA node. Upon approaching the region of the heart, the system 10 can be switched to ECG mode to enable ECG signals emitted by the SA node to be detected. As the stylet-loaded catheter is advanced toward the patient's heart, the electrically conductive ECG sensor assembly, including the distal end of the core wire 138 and the conductive material 146, begins to detect the electrical impulses produced by the SA node. As such, the ECG sensor assembly serves as an electrode for detecting the ECG signals. The elongate core wire 138 proximal to the core wire distal end serves as a conductive pathway to convey the electrical impulses produced by the SA node and received by the ECG sensor assembly to the tether 134.

[000122] The tether 134 conveys the ECG signals to the TLS sensor 50 temporarily placed on the patient's chest. The tether 134 is operably connected to the TLS sensor 50 via the tether connector 132 or other suitable direct or indirect connective configuration. As described, the ECG signal can then be processed and depicted on the system display 30 (FIG. 9, 10). Monitoring of the ECG signal received by the TLS sensor 50 and displayed by the display 30 enables a clinician to observe and analyze changes in the signal as the catheter distal tip 76A advances toward the SA node. When the received ECG signal matches a desired profile, the clinician can determine that the catheter distal tip 76A has reached a desired position with respect to the SA node. As mentioned, in one embodiment this desired position lies within the lower one-third (1/3rd) portion of the SVC.

[000123] The ECG sensor assembly and magnetic assembly can work in concert in assisting a clinician in placing a catheter within the vasculature. Generally, the magnetic assembly of the stylet 130 assists the clinician in generally navigating the vasculature from initial catheter insertion so as to place the distal end 76A of the catheter 72 in the general region of the patient's heart. The ECG sensor assembly can then be employed to guide the catheter distal end 76A to the desired location within the SVC by enabling the clinician to observe changes in the ECG signals produced by the heart as the stylet ECG sensor assembly approaches the SA node. Again, once a suitable ECG signal profile is observed, the clinician

can determine that the distal ends of both the stylet 130 and the catheter 72 have arrived at the desired location with respect to the patient's heart. Once it has been positioned as desired, the catheter 72 may be secured in place and the stylet 130 removed from the catheter lumen. It is noted here that the stylet may include one of a variety of configurations in addition to what is explicitly described herein. In one embodiment, the stylet can attach directly to the console instead of an indirect attachment via the TLS sensor. In another embodiment, the structure of the stylet 130 that enables its TLS and ECG-related functionalities can be integrated into the catheter structure itself. For instance, the magnetic assembly and/or ECG sensor assembly can, in one embodiment, be incorporated into the wall of the catheter.

[000124] FIGS. 13A-15 describe various details relating to the passage of ECG signal data from the stylet tether 134 to the TLS sensor 50 positioned on the patient's chest, according to the present embodiment. In particular, this embodiment is concerned with passage of ECG signal data from a sterile field surrounding the catheter 72 and insertion site 73, which includes the stylet 130 and tether 134, and a non-sterile field, such as the patient's chest on which the TLS sensor is positioned. Such passage should not disrupt the sterile field so that the sterility thereof is compromised. A sterile drape that is positioned over the patient 70 during the catheter insertion procedure defines the majority of the sterile field: areas above the drape are sterile, while areas below (excluding the insertion site and immediately surrounding region) are non-sterile. As will be seen, the discussion below includes at least a first communication node associated with the stylet 130, and a second communication node associated with the TLS sensor 50 that operably connect with one another to enable ECG signal data transfer therebetween.

[000125] One embodiment addressing the passage of ECG signal data from the sterile field to the non-sterile field without compromising the sterility of the former is depicted in FIGS. 13A-15, which depict a "through-drape" implementation also referred to as a "shark fin" implementation. In particular, FIG. 14A shows the TLS sensor 50 as described above for placement on the chest of the patient during a catheter insertion procedure. The TLS sensor 50 includes on a top surface thereof a connector base 152 defining a channel 152A in which are disposed three electrical base contacts 154. A fin connector 156, also shown in FIGS. 13A-13D, is sized to be slidably received by the channel 152A of the connector base 152, as shown in FIG. 14B and 15. Two ECG lead/electrode pairs 158 extend from the fin connector 156 for placement on the shoulder and torso or other suitable external locations on the patient

body. The drape-piercing tether connector 132 is configured to slidably mate with a portion of the fin connector 156, as will be described further below, to complete a conductive pathway from the stylet 120, through the sterile field to the TLS sensor 50.

[000126] FIGS. 13A-13D show further aspects of the fin connector 156. In particular, the fin connector 156 defines a lower barrel portion 160 that is sized to be received in the channel 152A of the connector base 152 (FIGS. 14B, 15). A hole 162 surrounded by a centering cone 164 is included on a back end of an upper barrel portion 166. The upper barrel portion 166 is sized to receive the tether connector 132 of the stylet 130 (FIGS. 14C, 15) such that a pin contact 170 extending into a channel 172 of the tether connector 132 (FIG. 15) is guided by the centering hole until it seats within the hole 162 of the fin connector 156, thus interconnecting the tether connector with the fin connector. An engagement feature, such as the engagement feature 169 shown in FIGS. 13C and 13D, can be included on either side of the fin connector 156 to engage with corresponding detents 173 (FIG. 13F) on the tether connector 132 to assist with maintaining a mating between the two components. If disengagement between the two components is desired, a sufficient reverse pull force is applied to the tether connector 132 while holding or securing the fin connector 156 to prevent its removal from the channel 152A of the connector base 152.

[000127] FIG. 13D shows that the fin connector 156 includes a plurality of electrical contacts 168. In the present embodiment, three contacts 168 are included: the two forward-most contact each electrically connecting with a terminal end of one of the ECG leads 158, and the rear contact extending into axial proximity of the hole 162 so as to electrically connect with the pin contact 170 of the tether connector 132 when the latter is mated with the fin connector 156 (FIG. 15). A bottom portion of each contact 168 of the fin connector 156 is positioned to electrically connect with a corresponding one of the base contacts 154 of the TLS sensor connector base 152. In one embodiment, the bottom portion of each contact 168 includes a retention feature, such as an indentation 168A. So configured, each contact 168 can resiliently engage a respective one of the base contacts 154 when the fin connector 156 is received by the TLS sensor connector base 152 such that a tip of each base contact is received in the respective indentation 168A. This configuration provides an additional securement (FIG. 15) to assist in preventing premature separation of the fin connector 156 from the connector base 152. Note that many different retention features between the base

contacts 154 and the fin contacts 168 can be included in addition to what is shown and described herein.

[000128] FIGS. 13E and 13F depict various details of the tether connector 132 according to one embodiment, including the tether connector channel 172, the pin contact 170 disposed in the channel, and detents 173 for removably engaging the engagement features 169 of the fin connector 156 (FIGS. 13A-13D), as described above. FIG. 13E further shows a plurality of gripping features 171 as an example of structure that can be included to assist the clinician in grasping the tether connector 132.

[000129] FIG. 14B shows a first connection stage for interconnecting the above described components, wherein the fin connector 156 is removably mated with the TLS sensor connector base 152 by the sliding engagement of the lower barrel portion 160 of the fin connector with the connector base channel 152A. This engagement electrically connects the connector base contacts 154 with the corresponding fin contacts 168 (FIG. 15).

[000130] FIG. 14C shows a second connection stage, wherein the tether connector 132 is removably mated with the fin connector 156 by the sliding engagement of the tether connector channel 172 with the upper barrel portion 166 of the fin connector. This engagement electrically connects the tether connector pin contact 170 with the back contact 168 of the fin connector 156, as best seen in FIG. 15. In the present embodiment, the horizontal sliding movement of the tether connector 132 with respect to the fin connector 156 is in the same engagement direction as when the fin connector is slidably mated to the sensor connector base channel 152A (FIG. 14B). In one embodiment, one or both of the stylet 130/tether connector 132 and the fin connector 156 are disposable. Also, the tether connector in one embodiment can be mated to the fin connector after the fin connector has been mated to the TLS sensor, while in another embodiment the tether connector can be first mated to the fin connector through the surgical drape before the fin connector is mated to the TLS sensor.

[000131] In the connection scheme shown in FIG. 14C, the stylet 130 is operably connected to the TLS sensor 50 via the tether connector 132, thus enabling the ECG sensor assembly of the stylet to communicate ECG signals to the TLS sensor. In addition, the ECG lead/electrode pairs 158 are operably connected to the TLS sensor 50. In one embodiment, therefore, the tether connector 132 is referred to as a first communication node for the stylet 130, while the fin connector 156 is referred to as a second communication node for the TLS

sensor 50. As will be seen, various other first and second communication nodes can be employed to enable the establishment of a conductive pathway between the ECG sensor assembly and the TLS sensor or other system component.

[000132] Note that various other connective schemes and structures can be employed to establish operable communication between the stylet and the TLS sensor. For instance, the tether connector can use a slicing contact instead of a pin contact to pierce the drape. Or, the fin connector can be integrally formed with the TLS sensor. These and other configurations are therefore embraced within the scope of embodiments of the present disclosure.

[000133] As mentioned, a drape 174 is often placed over the patient 70 and employed as a barrier to separate a sterile field of the patient, *e.g.*, areas and components above the drape and proximate to the insertion site 73 (including the catheter 72, the stylet 130, and tether 134 (FIG. 10)) from non-sterile areas outside of the sterile field, *e.g.*, areas and components below the drape, including the patient's chest, the sensor 50 (FIG. 10) placed on the chest, and regions immediately surrounding the patient 70, also referred to herein as a non-sterile field. As seen in FIG. 15, the sterile drape 174 used during catheter placement to establish the sterile field is interposed between the interconnection of the tether connector 132 with the fin connector 156. As just described, the tether connector 132 includes the pin contact 170 that is configured to pierce the drape 174 when the two components are mated. This piercing forms a small hole, or perforation 175, in the sterile drape 174 that is occupied by the pin contact 170, thus minimizing the size of the drape perforation by the pin contact. Moreover, the fit between the tether connector 132 and the fin connector 156 is such that the perforation in sterile drape made by piercing of the pin contact 170 is enclosed by the tether connector channel 172, thus preserving the sterility of the drape and preventing a breach in the drape that could compromise the sterile barrier established thereby. The tether connector channel 172 is shaped and configured so as to fold the sterile drape 174 down prior to piercing by the pin contact 170 such that the pin contact does not pierce the drape until it is disposed proximate the hole 162 of the fin connector 156 and such that the drape does not bunch up within the channel. It is noted here that the tether connector 132 and fin connector 156 are configured so as to facilitate alignment therebetween blindly through the opaque sterile drape 174, *i.e.*, via palpation absent visualization by the clinician of both components.

[000134] As already mentioned, note further that the fin contacts 168 of the fin connector 156 as shown in FIG. 15 include the indentations 168A, which are configured to mate with

the sensor base contacts 154 in such a way as to assist in retaining the fin connector in engagement with the sensor base channel 152A. This in turn reduces the need for additional apparatus to secure the fin connector 156 to the TLS sensor 50. In other embodiments, retention features that are separate from the electrical contacts can be employed to assist in retaining the fin connector in engagement with the sensor base channel. In one embodiment, the base contacts 154 can be configured as pogo pins such that they are vertically displaceable to assist in retaining the fin connector 156.

[000135] FIG. 16 shows a typical ECG waveform 176 of a patient, including a P-wave and a QRS complex. Generally, and with respect to the present system 10, the amplitude of the P-wave varies as a function of distance of the ECG sensor assembly from the SA node, which produces the P-wave of the waveform 176. A clinician can use this relationship in determining when the catheter tip is properly positioned proximate the heart. For instance, in one implementation the catheter tip is desirably placed within the lower one-third (1/3rd) of the superior vena cava, as has been discussed. The ECG data detected by the ECG sensor assembly of the stylet 130 is used to reproduce waveforms such as the waveform 176, for depiction on the display 30 of the system 10 during ECG mode.

[000136] Reference is now made to FIG. 17 in describing display aspects of ECG signal data on the display 30 when the system 10 is in ECG mode, the third modality described further above, according to one embodiment. The screenshot 178 of the display 30 includes elements of the TLS modality, including a representative image 120 of the TLS sensor 50, with the icon 114 corresponding to the position of the distal end of the stylet 130 during transit through the patient vasculature. The screenshot 178 further includes a window 180 in which the current ECG waveform captured by the ECG sensor assembly of the stylet 130 and processed by the system 10 is displayed. The window 180 is continually refreshed as new waveforms are detected.

[000137] Window 182 includes a successive depiction of the most recent detected ECG waveforms, and includes a refresh bar 182A, which moves laterally to refresh the waveforms as they are detected. Window 184A is used to display a baseline ECG waveform, captured before the ECG sensor assembly is brought into proximity with the SA node, for comparison purposes to assist the clinician in determining when the desired catheter tip location has been achieved. Windows 184B and 184C can be filled by user-selected detected ECG waveforms when the user pushes a predetermined button on the probe 40 or the console button interface

32. The waveforms in the windows 184B and 184C remain until overwritten by new waveforms as a result of user selection via button pushes or other input. As in previous modes, the depth scale 124, status/action indicia 126, and button icons 128 are included on the display 30. An integrity indicator 186 is also included on the display 30 to give an indication of whether the ECG lead/electrode pairs 158 are operably connected to the TLS sensor 50 and the patient 70.

[000138] As seen above, therefore, the display 30 depicts in one embodiment elements of both the TLS and ECG modalities simultaneously on a single screen, thus offering the clinician ample data to assist in placing the catheter distal tip in a desired position. Note further that in one embodiment a printout of the screenshot or selected ECG or TLS data can be saved, printed, or otherwise preserved by the system 10 to enable documentation of proper catheter placement.

[000139] Although the embodiments described herein relate to a particular configuration of a catheter, such as a PICC or CVC, such embodiments are merely exemplary. Accordingly, the principles of the present invention can be extended to catheters of many different configurations and designs.

[000140] FIGS. 18-19B depict examples of contact engagement configurations for the tether connector 132 and fin connector 156. Specifically, FIG. 18 depicts the fin contacts 168 of the fin connector 156 according to one embodiment, wherein the rear contact includes a spring clip configuration 168B for receiving the pin contact 170 (FIG. 15) of the tether connector 132 via the centering cone 164 or other aperture defined in the fin connector. FIGS. 19A and 19B depict an engagement scheme according to another embodiment, wherein the pin contact 170 of the tether connector 132 includes a barbed feature 170A that, when inserted into the centering cone 164 or other aperture of the fin connector 156, engages a shoulder 168C defined on the rear fin contact 168 of the fin connector so as to help prevent premature removal of the pin contact from the fin connector. These embodiments thus serve as non-limiting examples of a variety of contact configurations that can be included with the fin connector 156, the sensor connector base 152, and the tether connector 132. Note that unless referred to as otherwise, the contacts described herein are understood to include electrical contacts used in establishing a conductive pathway.

[000141] The embodiments to be described below in connection with FIGS. 20A-32 each depict an example connection scheme as a means for establishing a conductive or other communication pathway between a patient's sterile field and a non-sterile field, *i.e.*, areas outside of the sterile field. Thus, the embodiments described herein serve as examples of structure, material, and/or compositions corresponding to the means for establishing a conductive or other communication pathway. In particular, various embodiments described herein disclose examples for breaching or otherwise circumventing a sterile barrier separating the sterile field from the non-sterile field so as to provide at least a portion of the conductive pathway for the passage of ECG signals from a sensing component such as the ECG sensor assembly of the stylet 130 to the sensor 50, also referred to herein as a TLS sensor or chest sensor, or other suitable data-receiving component of the system 10. Note that these embodiments are merely examples of a variety of means for establishing such a conductive or other communication pathway, and are not to be considered limiting of the scope of the present disclosure. It is therefore appreciated that the means for establishing a conductive or other communication pathway can be employed for transferring ECG signals or other information, electrical signals, optical signals, etc.

[000142] As will be seen, many of the embodiments to be described include a tether connector, also referred to herein as a first communication node, which is operably connected to the stylet 130 and included in the sterile field, the tether connector is configured to operably attach to a connector included on the sensor 50 or other suitable component of the system 10, also referred to herein as a second communications node, which is disposed outside of the sterile field. Note, however, that the first communication node and second communication node are contemplated as generally referring to various connector interfaces that provide a conductive pathway from the sterile field to the non-sterile field to enable the passage of ECG signals as described above. It is appreciated that the conductive pathway is a communication pathway and includes an electrical pathway, an optical pathway, etc. Further, the communication node connection schemes described and contemplated herein can be employed with systems involving the use of modalities exclusive of ECG signals for navigation or placement of a catheter or other medical device.

[000143] Note further that the embodiments to follow that describe configurations for breaching a drape or other non-transparent sterile barrier are configured such that location of a communication node disposed out-of-sight under the drape/barrier is facilitated by

palpation of the clinician, thus easing location and connection of the first and second communication nodes. Also, many of the connector configurations described herein can be configured as one-use, disposable components so as to minimize concerns with infection.

[000144] Reference is now made to FIGS. 20A-20C, which depict a connection scheme as a means for establishing a conductive pathway between sterile and non-sterile fields, according to one embodiment. In particular, FIGS. 20A-20C depict a tether connector 232 that includes an outer housing 234 and a blade holder 236 that attaches to the outer housing. A blade contact 238 is secured by the blade holder 236 such that the blade contact extends into a channel 240 of the tether connector. The blade contact 238 serves to create a slice perforation in a drape that is interposed between the tether connector and the fin connector 256 when the tether connector 232 is slid on to engage the fin connector in the manner described in previous embodiments. As before, the outer housing 234 of the tether connector envelops and protects the perforation so as to prevent contamination and compromise of the sterile field.

[000145] FIG. 20C shows that a fin connector 256 includes a fin contact 268 that is configured to physically interconnect with the blade contact 238 when the tether connector is slid on to the fin connector 256, thus establishing a conductive pathway through the sheath so as to enable ECG signals from an ECG sensing component, *i.e.*, the ECG sensor assembly described above for instance, to pass to the sensor 50 via the blade contact 238/fin contact 268 engagement. Note that the particular configuration of the blade and fin contacts can be varied from what is described herein. For instance, the tether connector can include two or more blades or contacts for engagement with corresponding fin contacts to enable multiple conductive pathways to be established, if desired. The engagement surfaces of the tether connector and the fin connector can also vary from what is shown and described. In one embodiment, a light source can be included with the fin connector or other connectors as described herein so as to provide illumination through the drape 174 and provide visual assistance in locating the fin connector for interconnection with the tether connector.

[000146] As seen in FIGS. 14A and 14B, in one embodiment the ECG leads 158 are permanently connected to the fin connector 156. FIG. 21A depicts another possible embodiment, wherein the ECG leads are removably attached to the fin connector 156 via a connector, such as a horseshoe connector 270, best seen in FIG. 21B. FIG. 21A further shows that the fin connector 156 is permanently attached to the sensor 50. These and other

variations in the connective schemes of the various components of the system 10 are therefore contemplated as falling within the scope of the present disclosure. In another embodiment, the electrode of each lead is removably attachable from the lead, such as via a snap connection, for instance.

[000147] Reference is now made to FIGS. 22A-22C, which depict a connection scheme as a means for establishing a conductive pathway between sterile and non-sterile fields, according to one embodiment. In particular, FIGS. 22A-22C depict a tether connector 332 that includes a channel 372 for slidably engaging an upper barrel 166 of a fin connector 356 disposed on the sensor 50, in a manner similar to previous embodiments. The tether connector 332 includes a bi-positional top cap 374 to which is attached a pin contact 370 or other piercing contact.

[000148] The top cap 374 is positioned in an un-actuated first position, shown in phantom in FIG. 22B, when the tether connector 332 is first slid on to the fin connector 356. The drape, removed for clarity, is interposed between the upper barrel 166 of the fin connector 356 and the tether connector channel 372, similar to earlier embodiments. After the tether connector 332 is positioned on the fin connector 356, the top cap 374 can then be depressed by the clinician into an actuated second position shown in FIG. 22B, wherein the pin contact 370 is pressed downward through the drape and into operable engagement with a corresponding contact disposed in the fin connector 356. The tether connector 332 is thus positioned as shown in FIG. 22C. In addition to establishing a conductive path through the drape 174, this engagement of the pin contact 370 locks the tether connector 332 on to the fin connector 356 so as to prevent premature separation of the components.

[000149] Reference is now made to FIG. 23A and 23B, which depict a connection scheme as a means for establishing a conductive pathway between sterile and non-sterile fields, according to one embodiment. In particular, FIG. 23A depicts a tether connector 432 including a pin contact 440 or other suitable contact attached to an actuation assembly 442. The actuation assembly 442 includes lever arms for selectively lowering the pin contact 440 through an opening defined by a male end 448 of a housing 446 in which the actuation assembly is disposed. The male end 448 of the housing is configured to be received by a sensor connector receptacle 450 disposed on the sensor 50 or other suitable component of the system, such as a remote module operably connected to the sensor, for instance.

[000150] To interconnect the tether connector 432 to the sensor connector receptacle 450, the male end 448 of the tether connector 432 is brought, above the drape 174, into proximity with the receptacle 450. The actuation assembly 442 is then actuated by raising the lever arms 444, as shown in FIG. 23B. The pin contact 440 is forced downward through the drape 174, thus defining a perforation therein. The male end 448 can then be fully received into the sensor receptacle 450, wherein the pin contact 440 operably connects with a suitable contact of the sensor connector receptacle. The connector scheme shown in FIG. 23A and 23B is useful for imposing a minimal downward force on the body of the patient during connector interconnection. Further, the actuation assembly 442 provides a predetermined force in connecting the first communication node (the tether connector 432) with the second communication node (the sensor connector receptacle 450), and thus does not rely on a clinician's estimation of force to establish the node connection. In another embodiment, the housing 446 and the sensor receptacle 450 can be aligned and mated before the actuation assembly 442 is actuated to pierce the contact 440 through the drape.

[000151] Reference is now made to FIG. 24, which depicts a connection scheme as a means for establishing a conductive pathway between sterile and non-sterile fields, according to one embodiment. As in the embodiment shown in FIGS. 23A and 23B, the present interconnection scheme minimizes downward pressure on the body of the patient during interconnection of the nodes. As shown, a tether connector 532 includes a pin contact 540 or other suitable contact included with a threaded cap 542, which defines threads on an inside surface thereof. The threaded cap 542 is configured to threadingly receive a threaded base 544 disposed on the sensor 50 or other suitable component of the system, such as a remote module operably connected to the sensor, for instance. As before, the drape 174 is interposed therebetween.

[000152] To interconnect the tether connector 532 to the sensor 50, the threaded cap 542 of the tether connector is brought, above the drape 174, into proximity with the threaded base 544 and threaded on to the base. This causes the pin contact 540 to penetrate the drape 174, thus defining a perforation therein. Further threading of the cap 542 on to the base 544 causes the pin contact 540 to engage a contact receptacle 546 included in the base 544, thus operably interconnecting the two nodes. In one embodiment, the tether 134 is rotatably attached to the threaded cap 542 so as to prevent twisting of the tether during threading. The connector scheme shown in FIG. 24 is useful for imposing a minimal downward force on the

body of the patient during connector interconnection as the force to join the two connectors is directed laterally with respect to the patient via the threading operation. Note further that a variety of thread configurations and locations, as well as different cap and base configurations, are contemplated by the present disclosure.

[000153] Reference is now made to FIGS. 25A and 25B, which depict a connection scheme as a means for establishing a conductive pathway between sterile and non-sterile fields, according to one embodiment. As in the previous embodiment, the present interconnection scheme minimizes downward pressure on the body of the patient during interconnection of the nodes. As depicted in FIGS. 25A and 25B, a tether connector 632 includes one or more piercing contacts, such as pin contacts 640A and 640B that are respectively included on slide arms 642A and 642B. One or more contact receptacles, such as contact receptacles 644A and 644B, are included on a portion of the sensor 50, such as a sensor fin 646, or other suitable system component. As before, the drape 174 is interposed between the tether connector 632 and the sensor fin 646 to serve as a sterile barrier.

[000154] To interconnect the tether connector 632 to the sensor fin 646, the tether connector is brought, above the drape 174, into proximity with the sensor fin such that the slide arms 642A and 642B straddle the sensor fin and such that the pin contacts 640A and 640B are aligned with corresponding contact receptacles 644A and 644B, as shown in FIG. 25A. The slide arms 642A and 642B are then slid toward one another such that the pin contacts 640A and 640B penetrate the drape 174, each defining a perforation therein. The slide arms 642A and 642B are slid inward until the pin contacts 640A and 640B seat within and operably connect with the corresponding contact receptacles 644A and 644B, as seen in FIG. 25B, thus interconnecting the two nodes. The connector scheme shown in FIGS. 25A and 25B is useful for imposing a minimal downward force on the body of the patient during connector interconnection as the force to join the two connectors is directed laterally with respect to the patient. Note that the particular configuration of the tether connector, the sensor fin, and the contacts can vary from what is explicitly described herein. For instance, in one embodiment the slide arms can be configured as bi-positional rocker arms that are connected in a see-saw configuration with respect to one another. Also, one, two, or more contacts can be included on the slide arms.

[000155] Reference is now made to FIG. 26A and 26B, which depict a connection scheme as a means for establishing a conductive pathway between sterile and non-sterile fields,

according to one embodiment. As shown, an integrated connector 730 is incorporated into the drape 174 so as to enable operable interconnection therethrough. In the illustrated embodiment, the integrated connector 730 includes a conductive base portion 734 from which extend mechanical connectors, such as snap balls 736A and 736B.

[000156] As shown in FIG. 26B, the integrated connector 730 is positioned in the drape 174 as to be connectable with both a suitable receptacle 738 of a tether connector 732 and a suitable receptacle 740 of the sensor 50 or other suitable component of the system 10. In particular, the tether connector 732 can be snap-attached to the integrated connector 730, after which the integrated connector can be attached to the sensor 50, thus providing a suitable pathway for signals from the ECG sensor assembly in the sterile field to be transmitted through the sterile barrier of the drape 174 to the sensor in the non-sterile field. It is appreciated that, in other embodiments, the integrated connector can include other configurations, such as different mechanical connectors, *e.g.*, friction connectors, male/female connectors, etc., and as such the receptacles on the tether connector and sensor can likewise be modified to accommodate the different mechanical connectors. Also, the connective scheme described above can be reversed such that the receptacles are included on the integrated connector and the snap balls on the respective tether connector and sensor. Further, though presently depicted as a unitary component, the integrated connector in other embodiments can include two or more pieces that are attached to each other through a previously defined hole in the drape during manufacture thereof. These and other variations are therefore contemplated.

[000157] Reference is now made to FIG. 27, which depicts a connection scheme as a means for establishing a conductive pathway between sterile and non-sterile fields, according to one embodiment. In detail, FIG. 27 depicts an intermediate module, *i.e.*, ECG module 750, disposed outside of the sterile field of the patient, which is operably connected to the sensor 50 of the system 10 via a sensor cable 752. The ECG module 750 is also operably connected to the ECG leads 158. In one embodiment, the ECG module 750 includes the circuitry and other components necessary for receipt and analysis of the ECG signal detected by the ECG sensor assembly of the stylet 130. As such, a conductive pathway is established between the stylet 130 and the ECG module 750 by traversing the sterile field of the patient. In the present embodiment, this is accomplished by a tether connector 762 of the tether 134.

[000158] As depicted in FIG. 27, the tether connector 762 operably attaches to a receptacle 764 of the ECG module 750. As shown, the tether connector 762 can include a sufficiently long handle that enables the clinician to attach the sterile tether connector to the receptacle 764 of the non-sterile ECG module 750 without touching the ECG module itself, thus preventing any compromise of the sterile field. In one embodiment, the handle of the tether connector 762 can include an extendable J-hook contact, for instance, that can operably connect to a suitable contact of the ECG module.

[000159] FIG. 27 further depicts a footswitch 1116, usable with any of the embodiments described herein, which may be placed on the ground near the feet of the clinician and employed to control selected aspects of system functionality during catheter placement procedures. For instance, in one embodiment, the footswitch 1116 can be used to freeze ECG waveform images on the system display 30, or to create a printout of the display during the procedure, or even after the procedure is complete so as to provide a record of final catheter placement. Of course, the design and functionality of the footswitch can be modified in many ways from what is explicitly shown and described herein.

[000160] FIG. 28 shows another example of a tether connector that can be employed with the ECG module 750 of FIG. 27 or other suitable component of the system 10 as part of a connection scheme as a means for establishing a conductive pathway between sterile and non-sterile fields, according to one embodiment. In particular, FIG. 28 depicts a tether connector 832, which includes a handle and a barbed contact 836 or other suitable contact at a proximal end thereof. A sterile shield 838 is interposed between the handle 834 and the contact 836. The sterile shield 838 assists in protecting the hand of the clinician while inserting the contact 836 into the receptacle 764 of the ECG module 750 in a manner similar to what is shown in FIG. 27. Thus, the sterile shield 838 serves as an additional barrier to prevent inadvertent contact by the clinician with a component outside of the sterile field, such as the ECG module 750. Note that the size, shape, and particular configuration of the sterile shield and/or tether connector can vary from what is explicitly described in the present embodiment.

[000161] FIGS. 29A and 29B show yet another example of a connection scheme that can be employed with the ECG module 750 of FIG. 27 or other suitable component of the system 10 as a means for establishing a conductive pathway between sterile and non-sterile fields, according to one embodiment. In particular, FIG. 29A shows that the ECG module 750 can

be enveloped by a sterile bag 850. A connector, such as the integrated connector 730 described above in connection with FIGS. 26A and 26B, can be incorporated into the bag. As shown in FIG. 29B, an inner snap ball or other mechanical connector of the integrated connector 730 can be received by the suitably corresponding receptacle 764 of the ECG module 750. The tether connector of the system 10 can then be operably connected with the outer snap ball or other connector of the integrated connector 730, thus establishing a conductive pathway between the sterile field and the non-sterile field without compromising sterility. Note that the sterile bag 850 can include any one or more of a variety of suitable materials, including plastic. Note also that the integrated connector can include other connector configurations in addition to what is explicitly described herein. In one embodiment, the sterile bag includes no integrated connector, but rather is pierced by a pin contact of the tether connector, such as the barbed contact 836 included on the tether connector 832 of FIG. 28.

[000162] Reference is now made to FIG. 30, which depicts a connection scheme as a means for establishing a conductive pathway between sterile and non-sterile fields, according to one embodiment. Specifically, the stylet 130 includes a tether connector 862 as a first communication node, as in previous embodiments. A remote sensor connector 864 is also included as a second communications node, and is operably connected to the sensor 50 of the system 10 via a remote sensor connector cable 866. The tether connector 862 and remote sensor connector 864 operably connect to one another along a connection interface 868. The drape 174 that serves as a sterile barrier is interposed between the tether connector 862 and remote sensor connector 864 at the connection interface 868, and a suitable drape piercing configuration is included with the tether connector and the remote sensor connector to establish a conductive pathway through the drape. The present embodiment thus discloses one embodiment wherein the second communication node is located remotely with respect to the sensor 50.

[000163] Reference is now made to FIG. 31, which depicts a connection scheme as a means for establishing a conductive pathway between sterile and non-sterile fields, according to one embodiment. Specifically, the present embodiment includes the tether connector 862 and the remote sensor connector 864 that operably connect to one another along the connection interface 868, as described in connection with FIG. 30, above. The remote sensor connector 864 in the present embodiment is placed proximate the catheter insertion site 73 in a region

over which a fenestration 880 defined in the drape 174 (portions of the drape omitted for clarity) is positioned to enable clinician access to the insertion site during catheter placement. The remote sensor connector 864 is adhered to the patient's skin proximate the catheter insertion site 73 with the use of an adhesive, tape, etc., before the region surrounding the insertion site is sterilized in preparation for catheter insertion. Thus, when the insertion site is sterilized, the remote sensor connector 864 is also sterilized. Later, when connection of the tether connector 862 to the remote sensor connector 864 is made, the clinician can handle the latter component without compromising the sterile field of the patient. It is appreciated that the particular configurations of the tether connector and the remote sensor connector can vary while still residing within the scope of the present embodiment.

[000164] Reference is now made to FIG. 32, which depicts a connection scheme as a means for establishing a conductive pathway between sterile and non-sterile fields, according to one embodiment. Specifically, FIG. 32 shows the probe 40 employed by the system 10 for US functionality, as described above in connection with FIGS. 3A and 3B. A sterile sheath 900 is placed over the probe 40 so as to bring the probe into the sterile field of the patient. A connection interface, such as a receptacle 910, is included on the probe 900 and is configured so as to be operable connectable with a tether connector 920. In one embodiment, for example, the tether connector 920 includes a pin contact that penetrates the sterile sheath 900 to mate with the receptacle 910 in such a way as to prevent contamination of the sterile field. In this way, the tether connector 920, as a first communication node, operably connects with the probe 40, as a second communications node. In turn, the probe 40 is operably connected to the system console 20, as seen in FIG. 31 for example, so as to enable ECG signals received by the ECG sensor assembly of the stylet 130 via the tether connector 920 to be forwarded to the console, the sensor 50, or other system component for processing, as described above. In another embodiment, the receptacle 910 or other suitable connection interface can be included on the cable connecting the probe 40 to the system console 20. The particular contact configuration of the receptacle 910 and tether connector 920 can be varied according to the understanding of one skilled in the art. For instance, an integrated connector such as that shown in FIGS. 26A and 26B can be incorporated into the sterile sheath in one embodiment. Note further that, though including plastic in the present embodiment, the sterile sheath as described herein can include other suitable materials for providing sterility.

[000165] Reference is now made to FIG. 33 in describing means for establishing a conductive pathway between sterile and non-sterile fields, according to one embodiment. As shown, the tether 134 includes a wireless module 950, included within the sterile field, which serves as a first communication node for wirelessly transmitting (via RF or other suitable frequency or frequency range) ECG data received from the ECG sensor assembly of the stylet 130 to a data-receiving component as a second communication node, such as the sensor 50 or other suitable component of the system 10. A wireless module ground electrode 952 is operably connected with the wireless module 950 for placement in the sterile field proximate the catheter insertion site 73. A system ground electrode 158A extends from the sensor 50 for placement outside of the sterile field but proximate both the catheter insertion site 73 and the location of the wireless module ground electrode 952. One possible placement location for the system ground electrode 158A is beneath the patient arm, as depicted in FIG. 33. The system reference electrode 158B is placed on the lower torso of the patient 70 or other suitable location, as in previous embodiments. Note that the wireless module and system console as discussed herein can be configured in one or more of a variety of ways and include components for wireless signal transmission and reception not specifically detailed herein, such as patch or other antennas, signal transducers, etc.

[000166] With the system configured as shown in FIG. 33, the system ground electrode 158A can be electrically driven such that it produces a voltage that is sensed by the passive wireless module ground electrode 952, given its proximate location with respect to the system ground electrode. This enables both ground electrodes to be at substantially equal electric potentials, thus enabling the wireless module 950 to utilize the wireless module ground electrode 952 and the ECG signals from the ECG sensor assembly of the stylet 130, *e.g.*, the core wire 138 (FIGS. 12C-12E) in one embodiment, to detect and wirelessly transmit the ECG data to the sensor 50 for comparison with the data sensed by the system reference electrode 158B in order to obtain the desired P-wave waveform (*e.g.*, FIG. 16). The data comparison in one embodiment is a differential comparison between the ECG data as obtained by the ECG sensor assembly of the stylet 130, the wireless module ground electrode 952, and the system reference electrode 158B. In one embodiment, the system ground electrode 158A, like the wireless module ground electrode 952, can be passive and not electrically driven. Note also that the analog ECG data can be digitized or otherwise processed by the wireless module 950 before transmission to the sensor 50 or other system component, such as the console 20.

[000167] FIG. 34 describes yet another wireless configuration as a means for establishing a conductive pathway between sterile and non-sterile fields, according to one embodiment. As shown, a positive electrode 954A at a location A and a negative electrode 954B at a location B are included with the sensor 50 and positioned on the torso of the patient 70, while a positive wireless module electrode 956 is included with the wireless node 950, as indicated at location C, positioned on or in the patient proximate the catheter insertion site 73. The ECG sensor assembly of the stylet 130, *e.g.*, the core wire 138 in one embodiment, serves as a negative electrode for the wireless portion of the depicted configuration, indicated at D in FIG. 34 at its final position. Note that in one embodiment the locations A and B of the electrodes 954A and 954B, respectively, can be altered on the patient body to tune the system 10 for best ECG signal reception.

[000168] In the present embodiment, the electrodes 954A and 954B serve as a first independent source for sampling bipolar ECG signals. The ECG data from these electrodes are digitized and forwarded to the console 20 or other suitable system component via the cable interconnecting the sensor 50 and the console (path 1) outside of the sterile field. The wireless module electrode 956 and the ECG sensor assembly serve as a second independent source for sampling bipolar ECG signals. The ECG data from these electrodes are digitized and forwarded wirelessly to the console 20 via the wireless module 950 (path 2) within the sterile field. Thus, in the present embodiment the wireless module 950 serves as a first communication node, and a wireless receiver of the console 20 as a second communication node for the transfer of ECG signals between the two nodes. Note that the polarities of the afore-mentioned electrodes can be reversed in other embodiments.

[000169] The ECG signals received along both paths 1 and 2 are baseline corrected by appropriate circuitry of the console 20 to adjust for DC offset and drift. After such correction, a non-changing reference, or baseline, P-wave waveform 176A from path 1 can be produced, as seen in FIG. 35A, for example. Similarly, a P-wave waveform 176B as seen in FIG. 35B is produced from path 2, which waveform changes as the stylet 130 within the catheter 72 is advanced toward the heart of the patient. During such advancement, the waveform 176B from path 2 is subtracted from the P-wave waveform 176A from path 1, employing a digital differential amplifier, for instance. This subtraction removes all common components of the waveforms represented by each of the signals, and enables the console 20 to depict via its display 30 only the differences in the two signals, as seen for example by the

waveform 176C shown in FIG. 35C. The change in P-wave of the waveform from path 2 can then be easily observed during catheter advancement. Thus the present embodiment enables an easily observable digital display of ECG data to be represented while preventing a physical breaching of a sterile barrier, such as a surgical drape, for the passage of such data.

[000170] Note that in other embodiments the wireless module electrode 956 can include other configurations, including a conductive element imbedded into an introducer sheath, in contact with the bloodstream of the patient, which is commonly disposed through the insertion site 73 during catheter placement. The introducer can include a connector on a proximal portion thereof to enable a connection with the wireless node 950 to be made, in one embodiment.

[000171] Note further that one or more of a variety of wireless protocols can be employed in transmitting wireless signals in accordance with the embodiments described herein, including one or more of the IEEE 802.11 family of specifications, etc. Also note that in one embodiment the wireless module can be included in a sterile sheath, as described in previous embodiments, to bring the module within the sterile field, together with connectors for operably connecting the wireless module electrode through the sheath or included in the sheath itself. Of course, other methods for maintaining the wireless module within the sterile field can also be employed. In one embodiment, the wireless module can include buttons that further enable control of the system 10 from within the sterile field.

[000172] FIG. 36 shows that in one embodiment the sensor 50 can be retro-fitted with a wireless module 960 to enable signals received by the sensor to be wirelessly transmitted to the console 20 or other suitable component of the system 10. For instance, ECG data received by the ground and reference electrodes 158A, 158B (FIG. 34) can be received by the sensor 50 then wirelessly transmitted to the system console via the wireless module 960. The wireless module 960 can include an antenna or other transmitting component and can operably connect to the sensor 50 via a sensor cable 962 or other suitable interface. Note that the wireless module 960 can be employed in connection with other embodiments described herein, including those depicted in FIGS. 10 and 33, for instance.

[000173] FIG. 37 shows a retention feature for preventing inadvertent separation of the fin connector 156 from the sensor connector base 152 or other receptacle with which the fin connector operably connects, according to one embodiment. As shown, the fin connector 156

includes a retention arm 970 that is resiliently attached to the fin connector body. The retention arm 970 includes a tab 972 that slides over and engages a lip 974 included with the connector base 152 of the sensor 50 when the fin connector 156 is slidably received in the sensor channel 152A (FIG. 14A). The engagement of the tab 972 with the lip 974 prevents inadvertent removal of the fin connector 156 during use. When removal of the fin connector 156 from the sensor connector base 152 is desired, the retention arm 970 is lifted so as to disengage the tab 972 from the lip 974, after which the fin connector can be slid out of engagement with the sensor channel 152A. This configuration can be employed either with or independent of other retention features, such as the indentations 168A (FIG. 13D). Note that in other embodiments a variety of modifications and configurations can be employed in assisting to maintain engagement between the fin connector and the connector. For instance, the retention arm in one embodiment can be operably attached to one or more of the fin contacts 168 (FIG. 13D) such that displacement, *e.g.*, lifting laterally moving, pinching, etc., of the retention arm or other suitable fin connector component disengages the fin contact(s) from the base contacts (FIG. 15), thus reducing the overall retention force provided by the engagement of the fin contacts with the base contacts. Note further that these principles can be applied to the other connector schemes disclosed or contemplated in addition to the fin connector described here.

[000174] In addition to the above embodiments depicting various connection schemes as means for establishing a conductive pathway between sterile and non-sterile fields, other configurations can be employed, as appreciated by one skilled in the art, for performing the same functionality. Such other configurations can include, for example, wireless transmission of ECG signals from the stylet to the sensor or the system component, the inclusion of electrically conductive thread in the drape, the inclusion of an electrically conductive window (*e.g.*, composed of an electrically conductive plastic or foil) in the sterile drape, etc. In yet another embodiment, a proximal end of the stylet/guidewire itself can be used to pierce the drape for receipt into a connector on the sensor. In this case, no tether is included on the proximal end of the stylet, and the stylet itself serves as the conductive pathway for transmitting ECG signals from the stylet sensor assembly to the sensor on the patient's chest. Such a configuration can allow for over-the-wire placement of the catheter using a stylet/guidewire as described here. As such, the above embodiments should not be construed as being limiting of the present invention in any way.

[000175] FIG. 38 shows a catheter 982 as one example of a catheter that can be employed with the catheter placement system 10 described in the embodiments disclosed herein. The catheter 982 includes a conductive annular band 984, positioned proximate the distal end 982B (though other locations along the catheter are also possible), which serves as an ECG sensor, or electrode, for detecting ECG signals from an emitting heart node of the patient 70 when the catheter is at least partially inserted within the patient vasculature. A conductive wire 986 extends along the length of the catheter 982 and in one embodiment is embedded in the catheter wall, such as by co-extrusion for instance, for connection with external ECG signal receiving components external to the patient. Note that this is but one example embodiment of a catheter and ECG sensor electrode configuration, in addition to those described above and appreciated by one skilled in the art. Yet other possible configurations are disclosed in U.S. Publication No. 2010/0222664 titled "Catheter Assembly Including ECG Sensor and Magnetic Assemblies," which is incorporated herein by reference in its entirety.

[000176] FIG. 39 shows the catheter 982 for use with the system 10 including an ECG sensor assembly 990 according to one embodiment, wherein the catheter includes a plurality of ECG sensors, or electrodes 994A, 994B, and 994C. The electrode 994C is positioned proximate the catheter distal end 982B, while the remaining electrodes 994A and 994B are positioned on the catheter proximal thereto. Each electrode is operably connected to a respective conductive pathway, such as a conductive wire proximally extending from the electrode along the length of the catheter so as to enable detected ECG signals to be forwarded to the external TLS sensor 50 or other suitable system component. The electrodes 994A-994C can be configured in one or more of a variety of configurations suitable to act as sensors for detecting an ECG signal of the patient's heart. Also, though shown as close-ended, the catheter 982 can be open-ended in one embodiment.

[000177] As shown in FIGS. 40A-40C, the ECG sensor assembly 990 can be employed in determining the proximity of the catheter distal end 982B to the SA node, wherein the sensor assembly of the catheter 982 includes in the illustrated embodiment two electrodes 994A and 994B. In FIG. 40A, as the catheter distal end 982B approaches the SA node, the P-waves 996A and 996B of the ECG waveforms detected by the catheter electrodes 994A and 994B, respectively, both show an increase in P-wave amplitude. Because of its relatively more proximate position to the SA node, however, the electrode 994B shows a P-wave with a

relatively larger amplitude. A superposition of the P-waves 996A and 996B as detected by the system 10, for instance, is shown at 998. Observation of this relationship on the system display, for instance, can give needed information to a clinician during placement of the catheter so as to aid in advancement of the catheter distal end 982B toward the SA node.

[000178] FIG. 40B shows that when the two electrodes 994A and 994B are equidistant with respect to the SA node, the amplitudes of the P-waves 996A and 996B are approximately equal, which fact is further shown by the superposition 998 of the P-waves. In FIG. 40C, the distal electrode 994B is relatively farther from the SA node than the electrode 994A, and as such its corresponding P-wave 996B is smaller relative to the P-wave 996A. Note that the type and number of electrodes can be varied from what is shown here.

[000179] In another embodiment, a filtering process can be employed in connection with use of the ECG electrodes 994A, 994B of the catheter 982 described here, wherein portions of the ECG waveforms detected by the electrodes other than the P-wave portion are cancelled out, leaving only the differences in the detected P-waves between the two electrodes to be depicted. This process is similar to that employed in connection with FIGS. 34-35C, as described above.

[000180] FIGS. 41A-41C depict various possible states for the ECG electrode integrity indicator 186, also shown as displayed on the screenshot 178 of the system display 30 in FIG. 17. The integrity indicator 186 is an icon that is displayed on the system display 30 and is part of a connection integrity component to verify the status of the connections of the various ECG signal paths with the external sensor 50, *i.e.*, whether the connections are closed and ready for use during catheter placement procedures. Such lead verification is helpful to avoid having to remove the sterile drape and reinitiate the placement procedure if the various ECG electrodes were not properly connected before placement of the sterile drape and establishment of the sterile field about the patient.

[000181] In FIG. 41A, the integrity indicator 186 shows that no connections to the external sensor 50 are currently closed. In contrast, FIG. 41B shows that the connection between the sensor 50 and the ECG electrodes 158 (FIG. 14B) is closed, indicated by the shaded connection symbol 1004. FIG. 41C shows in addition that the connection between the sensor 50 and the ECG sensor of the stylet 130 (*e.g.*, the core wire 138 in FIGS. 12C and 12D via the tether 134 and tether connector 132) is closed, as indicated by the shaded connection

symbol 1006. Thus, the integrity indicator view in FIG. 41A represents the connection status shown in FIG. 14A, the indicator view in FIG. 41B represents the connection status shown in FIG. 14B, and the indicator view in FIG. 41C represents the connection status shown in FIG. 14C.

[000182] The system 10 can confirm the status of the above connections in one or more of a variety of ways using connection integrity components, including capacitive or inductive sensing circuits included with the sensor 50 and/or console 20 for instance, impedance-based methods, time or frequency reflectometry techniques, etc. One possible voltage balance-based connection integrity component system is shown at 1120 in FIG. 41D. In particular, the circuitry of the system 1120 includes a first resistor pair 1120 and an amplifier 1124, such as an instrumentation amplifier, operably connected via communication lines 1126, as are the other components of the present system, as shown in FIG. 41D. A second resistor pair 1128, amplifiers 1130 and 1132, an analog-to-digital converter ("ADC") 1134, and processor 1136 are also included in the system and interconnected as shown in FIG. 41D. The processor 1136 is included in the external TLS sensor 50 in one embodiment, but can be incorporated into other system processors or included in other components, such as the console 20 in one embodiment. The various ECG electrodes of the system 10 are shown attached to the body of the patient 70, *i.e.*, the internal ECG sensor (E1 in FIG. 41D) such as the stylet core wire 138 in the configuration shown in FIGS. 12A-12E, and both the external reference external ECG electrode 158 (E2) and second external electrode (E3) shown in FIGS. 14A-14C.

[000183] In preparation for use of the system 10, the integrity check system 1120 can be used to ensure that the external ECG electrodes are properly connected both to the body of the patient 70 and to the external TLS sensor 50 of the system 10 in one embodiment. Reference voltage V_{ref} , shown at 1140, is driven, such as by a voltage regulator, to a predetermined value, such as 4 volts, for instance, while the voltage at the external electrode E3 is maintained at a relatively lower value, such as 2 volts for instance. The values of the voltages V_1 and V_2 from the electrodes 1 and 2, respectively, in FIG. 41D are averaged to generate a common mode voltage, V_{cm} , indicated at 1142. In one embodiment, the processor 1136 monitors V_{cm} , as sampled via the ADC 1134. When the external ECG electrodes E2 and E3 are properly connected to the patient body and TLS sensor 50, V_{cm} will be pulled lower in value, in one embodiment approaching about 2 volts, though other values are possible. If one or both of the external electrodes E2 and E3 are not properly

connected, however, V_{cm} will be pulled higher toward the value of V_{ref} , or about 4 volts in the present embodiment. As such, monitoring of V_{cm} by the processor 1136 can determine the connectivity of the external ECG electrodes. These data relating to the connectivity status of the external ECG electrodes can be forwarded to the display 30 by the processor 1136 for depiction by the indicator 186 on the display 30 shown in FIGS. 41A-41C.

[000184] FIG. 42 shows yet another possible connection integrity component configuration according to one embodiment, wherein a passive lead continuity check system is employed, eliminating any need for injecting current into the leads that extend from the various ECG electrodes of the system 10. As shown, a radiating element 1010 is included relatively near the ECG electrode leads, such as on the sensor 50. The radiating element 1010 is configured to emit a signal of a known frequency. The ECG lead wires, such as the wires of the external ECG electrodes 158 and the tether 134, act as antennae to passively detect the signal radiated by the radiating element 1010. When the ECG leads are properly attached to the sensor 50, the antenna effect of the ECG lead wires is minimized, such that the radiating signal present on the ECG lead wires is suppressed. Sensor and/or console circuitry is configured so as to detect the radiating signal present on the ECG leads and compare it to a threshold signal level. If the detected radiating signal is above the threshold, the system reports that the ECG leads are not properly connected. When the detected signal is below the threshold, the system reports that the leads are properly connected. The present configuration is passive and does not necessitate the passing of current down the ECG leads in order to check connection integrity for the connective path check.

[000185] In one embodiment, the connection check scheme of FIG. 42 can be configured such that different graduated levels of signal present on the leads will indicate whether sub-connections upstream from the ECG electrode are closed. In another embodiment, natural signal line noise in the natural 60 Hz, 120 Hz or 180 Hz frequencies, naturally present on the lead wires, can be used for detection, thus eliminating the need for the radiating element 1010.

[000186] It is appreciated that other icons and designs can be used to implement the functionality described in connection with FIGS. 41A-41C, and that connection status checking can be varied according to modifications made to the catheter placement system. Of course, other visual or aural indications can be used to convey electrode connection status.

[000187] FIGS. 43A-43B depicts details of a stylet configuration including a mode for checking whether the stylet 130 has been inadvertently cut, such as when the stylet is undesirably left in the catheter lumen when the catheter 72 is trimmed before being inserted into the patient 70. As shown, in one embodiment, the stylet 130 can include a core wire 1014 and a plurality of magnetic elements 1016 covered by a tubing sleeve 1018, together with a conductive epoxy 1020 included at the stylet distal end. A conductive wire loop 1024 is included in the stylet and loops at the distal end 130B of the stylet 130 so as to form a circuit when suitably connected with the system 10. The conductive wire loop 1024 thus defines a continuity circuit that checks the continuity of the distal portion of the stylet. If the stylet has been inadvertently cut, such as by improper catheter trimming as shown in FIG. 43B, the loop is opened and the continuity check fails, indicating the catheter tip has been compromised. The continuity check can be performed before the catheter 72 is inserted into the patient vasculature so as to prevent catheter guidance problems after insertion. In another embodiment, the conductive wire loop 1024 could be configured so as to be exposed to the patient bloodstream and additionally serve as an ECG electrode.

[000188] FIG. 44 shows one of many possible variations to the previous embodiment, wherein the conductive wire loop 1024 is implemented as a planar wire, which has a bias toward bending within the plane of least thickness. Such a planar wire can be used in stylets that have a pre-curved configuration, such as that shown in FIG. 44. In addition, in one embodiment such a wire enables the direction of stylet bending to be controlled along one axis, if desired. Indeed, in one embodiment, tension can be imparted to the planar wire in order to cause the distal portion of the stylet 130 to selectively deflect from a straight to a curved configuration as shown in FIG. 44, for example. It should be noted that the embodiments just described can be implemented in stylets having one of a variety of configurations in terms of structure, size, etc. In other embodiments, Note that in other embodiments, other techniques can be employed to ensure the stylet has not been cut or otherwise compromised, including stylet checks using time or frequency domain reflectometry, for instance.

[000189] FIGS. 45 and 46 depict a mechanical solution for preventing unintended proximal advancement of the stylet 130 within the catheter 72. In particular, FIG. 45 shows a bulbous mechanical interference feature 1028 included on the stylet distal end 130B so as to impede retraction of the stylet into the catheter lumen. FIG. 46 shows another example, wherein the

stylet distal end 130B includes a deflected extended portion interference feature 1028. Of course, mechanical interference features of many different sizes and shapes can be employed, including arrow-shaped, spherical, etc.

[000190] FIG. 47A and 47B depict an electrical solution to assist in preventing misalignment of the distal ends of the catheter 72 and the stylet 130. As shown, a conduction band 1032 is embedded within the catheter so as to be in electrical communication with two conductive portions 1036 of the stylet 130 between which is interposed a nonconductive stylet portion 1034. When the stylet distal end 130B is properly aligned with the distal end 72B of the catheter 72, the more distal stylet conductive portion 1036 is conductively connected to the more proximal stylet conductive portion 1036 via the catheter-embedded conduction band 1032. Should the stylet and catheter distal ends 130B, 72B be misaligned, however, no such conductive path is established, and the absence of this path can be detected by the sensor 50, console 20, or other suitable component of the system 10 so as to enable its rectification.

[000191] FIG. 48 depicts one possible implementation of a dual ECG electrode assembly 1040 for placement on the skin of the patient 70 during catheter placement procedures. As shown, the assembly 1040 includes dual electrodes 1042A, 1042 B a single pad, for simplifying the ECG lead placement. Corresponding leads 1044 are also included. In other embodiments, the ECG electrode assembly can include more than two electrodes, if desired.

[000192] FIG. 49 shows one example of an external ECG external electrode assembly for placement on the skin of the patient 70, including the previously-described fin connector 156, and external ECG electrodes 158. Graphics 1048 are positioned on a surface of each electrode 158 including illustrations to assist the clinician in placing the ECG electrodes in the proper location on the patient's body. This assists clinicians who may not be familiar with the proper placement locations for the electrodes on the patient's body 70. The illustrations and particular electrode configuration can vary according to system design.

[000193] FIGS. 50-61 depict various possible implementations for displaying ECG data on a display of a catheter placement system, such as the display 30 of the system 10 of FIG. 10 for instance, for assisting a clinician in placing a catheter into the vasculature of the patient 70. In many of the implementations to follow, standard methods of presenting and displaying ECG data are improved to aid in catheter placement and confirmation of tip location. As

such, the following display and computing techniques may be useful in presenting data to a clinician.

[000194] FIG. 50 shows that audible or other suitable feedback can be employed in connection with displaying an ECG trace, such as an ECG trace 1050 shown here, which is similar to the trace history window 182 depicted on the display screenshot 178 in FIG. 17. In particular, in one embodiment a sound or other indicia can be correlated to an aspect of an ECG waveform of an ECG signal. In the present embodiment, an audible cue is associated with the amplitude of a P-wave 1052 of each waveform 176 in the ECG trace 1050. As the P-wave amplitude changes as shown in FIG. 50, the audible cue can correspondingly change. The audible cue can be modulated in frequency, volume, continuity (*e.g.*, discrete click vs. a continuous tone), etc.

[000195] FIG. 51 shows a flow chart depicting one embodiment of a method for correlating and producing audible or other feedback with respect to an aspect of the ECG waveform 176, such as the amplitude of the P-wave 1052. This method in whole or in part can be performed and/or controlled by suitable components of the system 10, *e.g.*, circuitry included in the external sensor 50 or console 20, or other suitable catheter or medical device placement system. In stage 1056, ECG signal data is sampled in a manner such as has been described above in connection with use of the system 10 during catheter placement procedures. In stage 1058, an ECG waveform is identified from the sampled ECG signal data. In stage 1060, a P-wave portion of the ECG waveform is identified. This can be accomplished, for instance, by comparing portions of the waveform with a standard, pre-loaded P-wave template to determine the existence and location of the P-wave 1052. The amplitude peak of the P-wave is then determined in stage 1062. In stage 1064, the P-wave amplitude peak is correlated to a corresponding audible or other suitable feedback output. This stage can be predetermined and stored by the system 10, or can be dynamically controlled automatically or by user input, in one embodiment. The output is then produced in stage 1066. Note that in other embodiments the output can be other than audible as has been described, including for instance visual, light/sound combinations, mechanical movement (vibratory), and/or other sensory cues, or combinations of the foregoing.

[000196] FIGS. 52-55 give further examples of visual output that can be correlated with aspects of ECG signal data, such as P-wave amplitude of each detected ECG waveform, using the method depicted in FIG. 51. For instance, FIG. 52 shows one display

implementation wherein the P-wave 1052 of each ECG waveform 176 is identified and highlighted with a color to differentiate the P-wave from other portions of the waveform. In one embodiment, the color can change according to changes in P-wave amplitude.

[000197] In FIG. 53, the peak amplitude of the P-wave 1052 in each waveform 176 is traced as a colored or shaded shadowing 1070 on the ECG trace 1050 as a function of time. In particular, during catheter insertion the P-waves 1052 of successive ECG waveforms 176 often vary in magnitude as the ECG sensor assembly of the catheter assembly (*e.g.*, the catheter and/or stylet) approaches the SA node or other node of the heart. It is often useful to display the magnitude of the P-waves 1052 on the system display 30 as such changes take place. A line or colored bar can be used to trace out the magnitude of past peaks. In this way, a comparison between current and former peak magnitudes can be conveniently made. This display mode can be employed whether the trace move across the display or if the traces remain stationary and are refreshed by a moving bar that sweeps across the display.

[000198] FIG. 54 shows that once the P-wave 1052 falls below a previous level, another color or shade of shadowing 1070 can be used, as seen in the left-most portion of the ECG trace 1050 of FIG. 54, to illustrate the difference between the most recent peaks and previous peaks. Optionally, a horizontal line 1074 can be used to trace out the peak of each P-wave 1052, as in FIG. 55. The line 1074 can be used either with or without the shadowing 1070. Of course, many other such tracing implementations and visual indicia can be devised in accordance with these principles.

[000199] Reference is made to FIGS. 56A-57B in describing aspects of scaling control of the ECG trace 150 as displayed in the trace history window 182 of the system display 30, for instance. In typical ECG devices, the rate of ECG waveform display is constant. However, human heart rates are not constant and ECG waveform formation and spacing vary from person to person. It may be beneficial to the observer to be able to change the number of waveforms and/or amount of time waveforms are displayed on the system display 30 or other suitable device. This allows more or fewer ECG waveforms to be displayed. In one embodiment, the clinician can adjust display settings to determine how many ECG waveforms 176 are displayed or how much time the waveforms are to be displayed. In one embodiment, the user can select from a series of pre-determined, discrete display time or waveform options, or the settings can be user-defined. In another embodiment, the control

over the display settings of the ECG trace 1050 can be dynamically or statically controlled autonomously by the system 10.

[000200] As examples of the above ECG trace time window variability, FIG. 56A shows the ECG waveforms 176 displayed as part of the ECG trace 1050 at a standard rate of four waveforms in the window, while FIG. 56B shows an increased ECG trace window including eight waveforms. Similarly, FIG. 57A shows ECG waveform data being displayed at a standard trace rate of five seconds, *i.e.*, each waveform 176 remains displayed for approximately five seconds; while FIG. 57B shows the ECG waveforms displayed at a relatively longer rate of approximately 10 seconds, *i.e.*, double the standard trace rate, such that the peaks appear relatively closer together. As shown in FIGS. 56A-57B, the physical width of the ECG trace window stays the same, with only the amount of waveforms displayed therein being modified.

[000201] FIG. 58 shows a flow chart depicting one embodiment of a method for displaying ECG signal data in the manner described above in connection with FIGS. 56A-57B. Note that this method in whole or in part can be performed and/or controlled by suitable components of the system 10, *e.g.*, circuitry included in the external sensor 50 or console 20, or other suitable catheter or medical device placement system. In stage 1080, ECG signal data is sampled in a manner such as has been described above in connection with use of the system 10 during catheter placement procedures. In stage 1082, an ECG waveform, such as the waveform 176 in FIGS. 56A-57B, is identified from the sampled ECG signal data. In stage 1084, parameters of a display window, such as the trace history window 182 shown in FIG. 17 for displaying the ECG trace 1050 of FIGS. 56A-57B, are defined. These parameters may be, for instance, the number of ECG waveforms to be included in the window, or the amount of time each waveform remains on screen. As stage 1088 shows, the parameters can be user-defined or autonomously defined and controlled in a static (*e.g.*, pre-set at factory) or dynamic (*e.g.*, automatically adjusted by the system according to feedback) manner. It is appreciated that the parameters can concern other display aspects of the ECG trace or waveforms, including for example waveform height, line width, etc. Further the parameters can be defined such that zero, one, two, or more ECG waveforms are displayed in the trace window before being refreshed, for instance.

[000202] In stage 1085, the ECG waveform is displayed according to the defined display window parameters. As shown, in one embodiment stage 1085 can include stages 1086 and

1090. In stage 1086 the ECG waveform is combined with previous waveforms if permitted by the parameters defined in stage 1084. In stage 1090, the ECG waveform is displayed together with any previous waveforms as permitted by the parameters defined in stage 1084.

[000203] FIG. 59 shows an individual trace window wherein a single ECG waveform 176 is displayed and is periodically refreshed as new waveforms are identified by the system 10 during catheter placement procedures, as has been described. Such a trace window is used, for example, for the current ECG waveform window 180 and windows 184A, 184B, and 184 C of the system display 30, as reflected by the display screenshot 178 shown in FIG. 17. As has been described, the ECG waveform 176 includes the P-wave 1052, and a QRS complex 1096. A ratio between the magnitude of the peak of the P-wave 1052 and the magnitude of the QRS complex 1096 can be displayed in the trace window as a numeric (as shown in FIG. 59) or other suitable format to assist the clinician in determining the change of the ECG waveform as the catheter 72 is advanced through the vasculature of the patient 70. The ratio is updated as each new ECG waveform is depicted in the individual trace window.

[000204] FIG. 60 shows a flow chart depicting one embodiment of a method for displaying an ECG waveform in the manner described above in connection with FIG. 59. Note that this method in whole or in part can be performed and/or controlled by suitable components of the system 10, *e.g.*, circuitry included in the external sensor 50 or console 20, or other suitable catheter or medical device placement system. In stage 1100, ECG signal data is sampled in a manner such as has been described above in connection with use of the system 10 during catheter placement procedures. In stage 1102, an ECG waveform, such as the waveform 176 in FIG. 59, is identified from the sampled ECG signal data. In stage 1104, a P-wave portion of the ECG waveform 176 is identified. This can be accomplished, for instance, by comparing portions of the waveform with a standard, pre-loaded P-wave template to determine the existence and location of the P-wave 1052.

[000205] In stage 1106, a ratio between the magnitude of the P-wave amplitude and a magnitude of the QRS complex amplitude 1096 is determined. In one embodiment, this stage may include determining the amplitude peak of the P-wave, identifying the QRS complex 1096 from the ECG waveform 176 and determining the magnitude of the QRS complex magnitude. In stage 1108, the ECG waveform 176 is displayed, such as in the current ECG waveform window 180 or one of the windows 184A, 184B, and 184 C of the system display 30 (FIG. 17). The waveform 176 can be displayed with the P-wave/QRS complex ratio data

acquired via stage 1106, if desired. As shown in FIG. 60, the process flow can be looped so as to acquire and display new ECG waveforms as they are produced and detected.

[000206] Stage 1110 includes a freeze image input option, wherein a user can select the displayed ECG waveform 176 and freeze it in the display, thus interrupting the looping of the process flow, or optionally preventing newly-acquired waveforms from being displayed. Also, during the process flow stage 1112 can be executed, wherein data relating to the identified ECG waveform is sent to a storage location or device. The stored image can then be displayed if desired, such as in one of the windows 184A, 184B, and 184 C of the system display 30 (FIG. 17).

[000207] FIG. 61 shows one example of a catheter placement record 1114 that can be printed and used for record keeping/documentation purposes to verify proper placement of the catheter 72 within the vasculature of the patient 70. The record 1114 can include, in one embodiment, a beginning ECG waveform 176A representing the ECG waveform when the catheter 72 is first introduced into the patient vasculature, and a final ECG waveform 176B representing the ECG waveform when the distal end of the catheter is positioned in its desired location proximate the patient's heart or other suitable location. An image representation 120 of the sensor 50 can be included with a stylet distal end icon 114 depicted on the sensor image to represent final placement of the stylet, and thus catheter as well. Date, time, patient ID, etc. can also be included in the record 1114. In one embodiment, a location for the clinician or responsible party to sign can also be included. The record 1114 can be user-modifiable via the system 10 in one embodiment so as to allow for customization for various hospital and clinic procedures and requirements. Printout of the record 1114 can be performed via an appropriate button included on the US probe 40, system console 20, etc. In another embodiment, the footswitch 1116 shown in FIG. 27 or other suitable interface can be used to capture and print the record 1114, if desired.

[000208] FIG. 62 shows yet another example of the catheter placement record 1114 that can be printed and used for record keeping/documentation purposes to verify proper placement of the catheter 72. The record 1114 can include, in one embodiment, three windows, with each window depicting the sensor image 120 and selected tip location and ECG waveform data. For instance, the record 1114 in FIG. 62 shows a left window including the beginning ECG waveform 176A and the corresponding ECG trace 1050 when the catheter 72 is first introduced to the vasculature, a middle window including the revised ECG trace 1050 and an

intermediate ECG waveform 176C representing the ECG waveform when the catheter is positioned as indicated by the stylet distal end icon 114, and a right window including the updated ECG trace 1050 and final position ECG waveform 176B representing the ECG waveform when the catheter is finally positioned as indicated by the stylet distal end icon 114. Of course, other configurations/information can be included in the record.

[000209] The various data acquired via use of the system 10 as described herein can be stored and/or evaluated for current or later use. In particular, in one embodiment both the TLS magnetic element tracking data and ECG signal detection data acquired via use of the system 10 can be stored for use as appreciated by those skilled in the art. In one embodiment, the TLS magnetic element tracking data for the catheter 72 and the ECG signal detection data can be associated with catheter position within the vasculature as a function of time so that a record of the catheter placement can be constructed in real time or at a later time via storage of the data. Such data can be stored in real time during the catheter placement procedure to operate as a fail-safe mode should the system temporarily and unexpectedly shut down during placement. Further, the data can be useful to pinpoint stylet position relative to the peak P-wave amplitude of the ECG signal by calculating the distance between the current stylet distal tip position and the position where P-wave amplitude is maximized. The data can also be employed to provide three dimensional information regarding the path along which the catheter is advanced within the patient vasculature.

Iconic Representations of Aspects of the Catheter or Medical Device

[000210] Reference is now made to FIGS. 63 and 64, which depict various components of the placement system ("system") 10, configured in accordance with one embodiment. As shown, the system 10 generally includes a console 20, display 30, probe 40, and sensor 50, each of which is described in further detail below. As the system 10 is similar in many respect to the systems already described above, only selected features are discussed below.

[000211] FIG. 64 shows the general relation of these components to a patient 70 during a procedure to place a catheter 72 into the patient vasculature through a skin insertion site 73. FIG. 64 shows that the catheter 72 generally includes a proximal portion 74 that remains exterior to the patient and a distal portion 76 that resides within the patient vasculature after placement is complete. In the present embodiment, the system 10 is employed to ultimately position a distal tip 76A of the catheter 72 in a desired position within the patient vasculature.

In one embodiment, the desired position for the catheter distal tip 76A is proximate the patient's heart, such as in the lower one-third (1/3rd) portion of the Superior Vena Cava ("SVC"). Of course, the system 10 can be employed to place the catheter distal tip in other locations. The catheter proximal portion 74 further includes a hub 74A that provides fluid communication between the one or more lumens of the catheter 72 and one or more extension legs 74B extending proximally from the hub.

[000212] An example implementation of the console 20 is shown in FIG. 8C above, though it is appreciated that the console can take one of a variety of forms. A processor 22, including non-volatile memory such as EEPROM for instance, is included in the console 20 for controlling system function during operation of the system 10, thus acting as a control processor. A digital controller/analog interface 24 is also included with the console 20 and is in communication with both the processor 22 and other system components to govern interfacing between the probe 40, sensor 50, and other system components.

[000213] The system 10 further includes ports 52 for connection with the sensor 50 and optional components 54 including a printer, storage media, keyboard, etc. The ports in one embodiment are USB ports, though other port types or a combination of port types can be used for this and the other interfaces connections described herein. A power connection 56 is included with the console 20 to enable operable connection to an external power supply 58. An internal battery 60 can also be employed, either with or exclusive of an external power supply. Power management circuitry 59 is included with the digital controller/analog interface 24 of the console to regulate power use and distribution.

[000214] The display 30 in the present embodiment is integrated into the console 20 and is used to display information to the clinician during the catheter placement procedure. In another embodiment, the display may be separate from the console. As will be seen, the content depicted by the display 30 changes according to which mode the catheter placement system is in: US, TLS, or in other embodiments, ECG tip confirmation. In one embodiment, a console button interface 32 and buttons included on the probe 40 can be used to immediately call up a desired mode to the display 30 by the clinician to assist in the placement procedure. In one embodiment, information from multiple modes, such as TLS and ECG, may be displayed simultaneously. Thus, the single display 30 of the system console 20 can be employed for ultrasound guidance in accessing a patient's vasculature, TLS guidance during catheter advancement through the vasculature, and (as in later embodiments) ECG-based

confirmation of catheter distal tip placement with respect to a node of the patient's heart. In one embodiment, the display 30 is an LCD device.

[000215] The probe 40 is employed in connection with the first modality mentioned above, *i.e.*, ultrasound ("US")-based visualization of a vessel, such as a vein, in preparation for insertion of the catheter 72 into the vasculature. Such visualization gives real time ultrasound guidance for introducing the catheter into the vasculature of the patient and assists in reducing complications typically associated with such introduction, including inadvertent arterial puncture, hematoma, pneumothorax, etc.

[000216] As such, in one embodiment a clinician employs the first, US, modality to determine a suitable insertion site and establish vascular access, such as with a needle or introducer, then with the catheter. The clinician can then seamlessly switch, via button pushes on the probe button pad, to the second, TLS, modality without having to reach out of the sterile field. The TLS mode can then be used to assist in advancement of the catheter 72 through the vasculature toward an intended destination.

[000217] FIG. 63 shows that the probe 40 further includes button and memory controller 42 for governing button and probe operation. The button and memory controller 42 can include non-volatile memory, such as EEPROM, in one embodiment. The button and memory controller 42 is in operable communication with a probe interface 44 of the console 20, which includes a piezo input/output component 44A for interfacing with the probe piezoelectric array and a button and memory input/output component 44B for interfacing with the button and memory controller 42.

[000218] Note that while a vein is typically depicted on the display during use of the system 10 in the US modality, other body lumens or portions can be imaged in other embodiments. Note that the US mode can be simultaneously depicted on the display 30 with other modes, such as the TLS mode or ECG mode, if desired. In addition to the visual display 30, aural information, such as beeps, tones, etc., can also be employed by the system 10 to assist the clinician during catheter placement. Moreover, the buttons included on the probe 40 and the console button interface 32 can be configured in a variety of ways, including the use of user input controls in addition to buttons, such as slide switches, toggle switches, electronic or touch-sensitive pads, etc. Additionally, US, TLS, and ECG activities can occur simultaneously or exclusively during use of the system 10.

[000219] As just described, the handheld ultrasound probe 40 is employed as part of the integrated catheter placement system 10 to enable US visualization of the peripheral vasculature of a patient in preparation for transcutaneous introduction of the catheter. In the present example embodiment, however, the probe is also employed to control functionality of the TLS portion, or second modality, of the system 10 when navigating the catheter toward its desired destination within the vasculature as described below. Again, as the probe 40 is used within the sterile field of the patient, this feature enables TLS functionality to be controlled entirely from within the sterile field. Thus the probe 40 is a dual-purpose device, enabling convenient control of both US and TLS functionality of the system 10 from the sterile field. In one embodiment, the probe can also be employed to control some or all ECG-related functionality, or third modality, of the catheter placement system 10, as described further below.

[000220] The catheter placement system 10 further includes the second modality mentioned above, *i.e.*, the magnetically-based catheter TLS, or tip location system. The TLS enables the clinician to quickly locate and confirm the position and/or orientation of the catheter 72, such as a peripherally-inserted central catheter ("PICC"), central venous catheter ("CVC"), or other suitable catheter or medical device, during initial placement into and advancement through the vasculature of the patient 70. Specifically, the TLS modality detects a magnetic field generated by a magnetic element-equipped tip location stylet, which is pre-loaded in one embodiment into a longitudinally defined lumen of the catheter 72, thus enabling the clinician to ascertain the general location and orientation of the catheter tip within the patient body. In one embodiment, the magnetic assembly can be tracked using the teachings of one or more of the following U.S. patents: 5,775,322; 5,879,297; 6,129,668; 6,216,028; and 6,263,230. The contents of the afore-mentioned U.S. patents are incorporated herein by reference in their entireties. The TLS also displays the direction in which the catheter tip is pointing, thus further assisting accurate catheter placement. The TLS further assists the clinician in determining when a malposition of the catheter tip has occurred, such as in the case where the tip has deviated from a desired venous path into another vein.

[000221] As mentioned, the TLS utilizes a stylet to enable the distal end of the catheter 72 to be tracked during its advancement through the vasculature. In one embodiment, the stylet includes a proximal end and a distal end, with a handle included at the proximal end and a core wire extending distally therefrom. A magnetic assembly is disposed distally of the core

wire. The magnetic assembly includes one or more magnetic elements disposed adjacent one another proximate the stylet distal end and encapsulated by tubing. In the present embodiment, a plurality of magnetic elements is included, each element including a solid, cylindrically shaped ferromagnetic stacked end-to-end with the other magnetic elements. An adhesive tip can fill the distal tip of the tubing, distally to the magnetic elements.

[000222] Note that in other embodiments, the magnetic elements may vary from the design in not only shape, but also composition, number, size, magnetic type, and position in the stylet distal segment. For example, in one embodiment, the plurality of ferromagnetic magnetic elements is replaced with an electromagnetic assembly, such as an electromagnetic coil, which produces a magnetic field for detection by the sensor. Another example of an assembly usable here can be found in U.S. Patent No. 5,099,845 titled "Medical Instrument Location Means," which is incorporated herein by reference in its entirety. Yet other examples of stylets including magnetic elements that can be employed with the TLS modality can be found in U.S. Publication No. 2007/0049846 titled "Stylet Apparatuses and Methods of Manufacture," which is incorporated herein by reference in its entirety. These and other variations are therefore contemplated by embodiments of the present invention. It should be appreciated herein that "stylet" as used herein can include any one of a variety of devices configured for removable placement within a lumen of the catheter to assist in placing a distal end of the catheter in a desired location within the patient's vasculature. In one embodiment, the stylet includes a guidewire.

[000223] FIG. 64 shows disposal of a stylet 130 substantially within a lumen in the catheter 72 such that the proximal portion thereof extends proximally from the catheter lumen, through the hub 74A and out through a selected one of the extension legs 74B. So disposed within a lumen of the catheter, the distal end 100B of the stylet 100 in the present embodiment is substantially co-terminal with the distal catheter end 76A such that detection by the TLS of the stylet distal end correspondingly indicates the location of the catheter distal end. In other embodiments, other relationships between the distal ends of the stylet and catheter or medical device are possible.

[000224] The TLS sensor 50 is employed by the system 10 during TLS operation to detect a magnetic field produced by the magnetic elements 106 of the stylet 100. As seen in FIG. 2, the TLS sensor 50 is placed on the chest of the patient during catheter insertion. The TLS sensor 50 is placed on the chest of the patient in a predetermined location, such as through the

use of external body landmarks, to enable the magnetic field of the stylet magnetic elements, disposed in the catheter 72 as described above, to be detected during catheter transit through the patient vasculature. Again, as the magnetic elements of the stylet magnetic assembly are co-terminal with the distal end 76A of the catheter 72 (FIG. 64), detection by the TLS sensor 50 of the magnetic field of the magnetic elements provides information to the clinician as to the position and orientation of the catheter distal end during its transit.

[000225] In greater detail, the TLS sensor 50 is operably connected to the console 20 of the system 10 via one or more of the ports 52, as shown in FIG. 63. Note that other connection schemes between the TLS sensor and the system console can also be used without limitation. As just described, the magnetic elements are employed in the stylet 100 to enable the position of the catheter distal end 76A (FIG. 64) to be observable relative to the TLS sensor 50 placed on the patient's chest. Detection by the TLS sensor 50 of the stylet magnetic elements 106 is graphically displayed on the display 30 of the console 20 during TLS mode. In this way, a clinician placing the catheter is able to generally determine the location of the catheter distal end 76A within the patient vasculature relative to the TLS sensor 50 and detect when catheter malposition, such as advancement of the catheter along an undesired vein, is occurring.

[000226] As discussed above, the system 10 includes additional functionality in the present embodiment wherein determination of the proximity of the catheter distal tip 76A relative to a sino-atrial ("SA") or other electrical impulse-emitting node of the heart of the patient 70 can be determined, thus providing enhanced ability to accurately place the catheter distal tip in a desired location proximate the node. Also referred to herein as "ECG" or "ECG-based tip confirmation," this third modality of the system 10 enables detection of ECG signals from the SA node in order to place the catheter distal tip in a desired location within the patient vasculature. Note that the US, TLS, and ECG modalities are seamlessly combined in the present system 10, but can be employed in concert or individually to assist in catheter placement. In one embodiment, it is understood that the ECG modality as described herein can be included in a stand-alone system without the inclusion of the US and TLS modalities. Thus, the environments in which the embodiments herein are described are understood as merely example environments and are not considered limiting of the present disclosure.

[000227] As described, the catheter stylet 130 is removably predisposed within the lumen of the catheter 72 being inserted into the patient 70 via the insertion site 73. The stylet 130, in addition to including a magnetic assembly for the magnetically-based TLS modality, includes

a sensing component, *i.e.*, an ECG sensor assembly, proximate its distal end and including a portion that is co-terminal with the distal end of the catheter tip for sensing ECG signals produced by the SA node. The stylet 130 includes a tether 134 extending from its proximal end that operably connects to the TLS sensor 50. As will be described in further detail, the stylet tether 134 permits ECG signals detected by the ECG sensor assembly included on a distal portion of the stylet 130 to be conveyed to the TLS sensor 50 during confirmation of the catheter tip location as part of the ECG signal-based tip confirmation modality. Reference and ground ECG electrodes attach to the body of the patient 70 in the present embodiment and are operably attached to the TLS sensor 50 to enable the system to filter out high level electrical activity unrelated to the electrical activity of the SA node of the heart, thus enabling the ECG-based tip confirmation functionality. Together with the reference and ground signals received from the ECG electrodes placed on the patient's skin, the ECG signals sensed by the stylet ECG sensor assembly are received by the TLS sensor 50 positioned on the patient's chest (FIG. 10) or other designated component of the system 10. The TLS sensor 50 and/or console processor 22 can process the ECG signal data to produce one or more electrocardiogram waveform, or traces, on the display 30, as will be described. In the case where the TLS sensor 50 processes the ECG signal data, a processor is included therein to perform the intended functionality. If the console 20 processes the ECG signal data, the processor 22, controller 24, or other processor can be utilized in the console to process the data.

[000228] Thus, as it is advanced through the patient vasculature, the catheter 72 equipped with the stylet 130 as described above can advance under the TLS sensor 50, which is positioned on the chest of the patient as shown in FIG. 10. This enables the TLS sensor 50 to detect the position of the magnetic assembly of the stylet 130, which is substantially co-terminal with the distal tip 76A of the catheter as located within the patient's vasculature. The detection by the TLS sensor 50 of the stylet magnetic assembly is depicted on the display 30 during ECG mode. The display 30 can further depict during ECG mode an ECG electrocardiogram trace produced as a result of patient heart's electrical activity as detected by the ECG sensor assembly (also referred to herein as an ECG sensor component) of the stylet 130. In greater detail, the ECG electrical activity of the SA node, including the P-wave of the trace, is detected by the ECG sensor assembly of the stylet and forwarded to the TLS sensor 50 and console 20. The ECG electrical activity is then processed for depiction on the display 30. A clinician placing the catheter can then observe the ECG data to determine

optimum placement of the distal tip 76A of the catheter 72, such as proximate the SA node in one embodiment. In one embodiment, the console 20 includes the electronic components, such as the processor 22 (FIG. 63), necessary to receive and process the signals detected by the stylet ECG sensor assembly. In another embodiment, the TLS sensor 50 can include the necessary electronic components processing the ECG signals.

[000229] As already discussed, the display 30 is used to display information to the clinician during the catheter placement procedure. The content of the display 30 changes according to which mode the catheter placement system is in: US, TLS, or ECG. Any of the three modes can be immediately called up to the display 30 by the clinician, and in some cases information from multiple modes, such as TLS and ECG, may be displayed simultaneously. In one embodiment, as before, the mode the system is in may be controlled by the control buttons included on the handheld probe 40, thus eliminating the need for the clinician to reach out of the sterile field (such as touching the button interface 32 of the console 20) to change modes. Thus, in the present embodiment the probe 40 is employed to also control some or all ECG-related functionality of the system 10. Note that the button interface 32 or other input configurations can also be used to control system functionality. Also, in addition to the visual display 30, aural information, such as beeps, tones, etc., can also be employed by the system to assist the clinician during catheter placement.

[000230] In light of the above discussion relating to FIGS. 63 and 64, FIGS. 65-75 depict various details regarding systems and methods for depicting multi-dimensional position and orientation information relating to a distal portion of a catheter (or other indwelling medical device) during procedures for placing the catheter within the body of a patient. In one embodiment, the multi-dimensional position and orientation information is embodied in an icon depicted on the display 30 of the system 10, which is configured for accurately placing the catheter within the vasculature of a patient, as described above. In one embodiment, the system 10 employs the tip location/navigation system ("TLS mode") employing magnetically-based tracking of the catheter tip during its advancement through the tortuous vasculature path to detect and facilitate correction of any tip malposition during such advancement. In addition, the system 10 includes in one embodiment other modalities for improving catheter placement accuracy, including ultrasound-assisted guidance ("US mode") for introducing the catheter into the patient's vasculature, and ECG signal-based catheter tip guidance ("ECG mode") to enable guidance of the catheter tip to a desired position with

respect to a node of the patient's heart from which the ECG signals originate. Such ECG-based positional assistance is also referred to herein as "tip confirmation." Depiction of the icon on the system display 30 can occur in connection with TLS mode, ECG mode, or another suitable mode executed by the system 10, as appreciated by one skilled in the art.

[000231] As described above and in connection with the embodiments already discussed, the icon 114 is depicted by the system 10 on the display 30 to convey information relating to detection of the distal portion of the stylet 130 disposed in the catheter 72. The icons to be discussed below can be used in the embodiments already discussed in connection with the system 10.

[000232] In accordance with one embodiment, the icon 114 can visually indicate various pieces of information regarding the position, orientation, and other aspects of the stylet distal end, and thus the distal end of the catheter itself, as already described. FIG. 65 show various examples of the icon 114 in depicting both position and orientation information of the stylet distal end as detected by the system 10 in TLS and/or ECG mode. In particular, the various views of the icon 114 in FIG. 65 include both an orientation indicator 1502, which depicts the orientation of a distal portion of the stylet 130 (FIG. 63, 64), and a position and depth indicator 1504, which depicts indicate the position and depth of the stylet distal end.

[000233] In greater detail and as mentioned, the orientation indicator 1502 of the icon 114 depicts on the display 30 the orientation, or "yaw," of the stylet, *i.e.*, the direction the stylet tip is pointing, as detected by the sensor 50 (FIGS. 63, 64). In the present embodiment, the orientation indicator 1502 is implemented as an elongate rod 1512, as shown. The orientation of the rod 1512 as depicted on the display 30 during system operation represents the portion of the stylet proximal to the distal end thereof, thus indicating the direction from which the stylet distal end has advanced. As the stylet moves within the vasculature, the icon 114 and its rod 1512 correspondingly move on the display 30.

[000234] The position and depth indicator 1504 of the icon 114 denotes both the two-dimensional position of the stylet distal tip, *i.e.*, the tip position in the x-y plane of the x-y-z coordinate axis as shown in FIG. 64, as well as the depth of the stylet tip within the patient, as detected by the sensor 50 (FIG. 64). In the present embodiment, the position and depth indicator 1504 is implemented as a concentric circle array ("circle array") 1514, as shown.

[000235] The center of the circle array 1514 indicates the x-y position of the stylet distal tip within the patient body and with respect to the sensor 50, while the relative size of the circle array indicates the depth thereof. For instance, the left-most icon 114 in FIG. 65 includes relatively many concentric circles included in its circle array 1514, indicating that the stylet distal tip is relatively proximate to the sensor 50, or at a relatively shallow depth within the patient body, which corresponds to a position along the vertical, or z-axis, of the x-y-z coordinate axis shown in FIG. 64.

[000236] In contrast, the right-most icon 114 includes relatively few concentric circles in its circle array 1514, indicating that the stylet distal tip is relatively far from the sensor 50, or at a relatively deeper depth within the patient body. Thus, the appearance of the rod 1512 and circle array 1514 of the icon 114 on the display 30 can indicate to a user of the system 10 the spatial status of the stylet distal end in four-dimensions: its x-y-z axis position and depth three-dimensional location, and its yaw orientation (*i.e.*, the fourth dimension). Such an icon depiction provides useful and readily identifiable information to the clinician placing the catheter, wherein the depth indication provided by the icon 114 described above can be used to determine when the catheter is malpositioned within the vasculature. Of course, other medical devices can be similarly tracked, other shapes and configurations for the orientation and position/depth indicators can be used, and stylet tip aspects in addition to orientation, position, and depth can be depicted, as will be seen.

[000237] FIG. 70 depicts the icon 114 and its corresponding orientation indicating rod 1512 and position/depth indicating circle array 1514 according to the present embodiment, together with examples of corresponding stylet distal tip depths within the patient body as detected by the system sensor 50 (FIG. 64). Of course, this is merely one example of icon size-to-depth correspondence; others are also possible. In addition, the icon features shown herein can be employed to represent other aspects of the detected stylet tip or other suitable indwelling medical device, in other embodiments.

[000238] FIG. 66 depicts a method 1530 in which the system 10 or other suitable device can detect, calculate, and depict the icon 114, according to one embodiment. In stage 1532 multiple strength measurements are taken from the various sensor components included in the sensor 50 from their detection of the magnetic assembly of the stylet in TLS mode (FIG. 64). These measurements are used in stage 1534 to calculate position and orientation data for the stylet distal tip. Particularly, in stages 1536 and 1538 the x and y positions of the stylet distal

tip are calculated, then depicted on the display 30 of the system 10 at stage 1540. As mentioned, in the embodiment shown in FIG. 65, the x-y position of the stylet distal tip is displayed as the center of the circle array 1514 of the icon 114.

[000239] Similarly, in stage 1542 the z position of the stylet distal tip is calculated, then depicted on the display 30 at stage 1544. As mentioned, in the embodiment shown in FIG. 65, the z position of the stylet distal tip is displayed as the circle array 1514 of the icon 114, with a relatively larger array size indicating a shallower stylet distal tip z position within the patient body.

[000240] In stage 1546 the orientation of the stylet distal tip is calculated, then depicted on the display 30 at stage 1548. As mentioned, in the embodiment shown in FIG. 65, the orientation of the distal portion of the stylet is displayed as the rod 1512, with the longitudinal extension thereof indicating the direction from which the stylet distal tip has immediately travelled within the patient body. Stages in addition to or instead of the stages discussed here can also be included in the method 1530, in one embodiment. Note that the calculations of stages 1536, 1538, 1542, and 1546 can be performed by the processor 22 of the system console 20 (FIG. 63) in one embodiment, or by another suitable system component.

[000241] FIGS. 67A-67F depict examples of other possible configurations for the icon 114 in depicting four-dimensional information relating to the three-dimensional position and orientation (*i.e.*, the fourth dimension) of the stylet distal end. FIG. 67A shows the icon 114 including the rod 1512 and the concentric circle array 1514, as was discussed in connection with FIG. 65. In FIG. 67B, the icon 114 includes the rod 1512 as an orientation indicator and a position and depth indicator implemented as a concentric circle array. In particular, the circle array can include both solid rings 1514A and faded rings 1514B. As stylet distal depth increases, the number of faded rings 1514B increases, replacing formerly present solid rings 1514A.

[000242] In FIG. 67C, the icon 114 includes the rod 1512, which serves as an orientation indicator, and a fixed-size concentric circle array 1510A that serves as a tip icon 1510 to show x-y stylet distal tip position. A bar graph 1514B is included adjacent the tip icon 1510. Relatively more of the bars of the bar graph 1514B are solidly filled (in black & white scheme, color, etc.) or otherwise altered when the stylet distal tip is positioned in a shallow

depth relative the sensor 50, and *vice versa*. Instead of a bar graph, the embodiment shown in FIG. 67D includes a vertical scale 1564 with an arrow 1566 that slides along the vertical scale to indicate stylet distal tip depth, wherein the arrow slides lower on the vertical scale as tip depth increases.

[000243] In FIG. 67E, the icon 114 includes the rod 1512 to indicate stylet distal tip orientation and the fixed tip icon 1510 to indicate x-y tip position. In addition, the length of the rod 1512 varies according to tip depth, with a relatively shorter rod length indicating deeper tip depth. In FIG. 67F, the rod 1512 includes a plurality of rod segments 1574 that vary in number according to stylet distal tip depth, with a relatively fewer number of rod segments visible indicating deeper tip depth. Note that the various icon elements described herein can be utilized to indicate other aspects of the stylet distal tip, catheter, or other medical device. For instance, the bar graph 1554 used to indicate stylet tip depth in the icon 114 of FIG. 67C can be used in another embodiment to indicate a confidence level (determined by the system 10) with regard to the position, orientation, etc., of the stylet distal tip. Likewise, the rod segments 1574 used to indicate stylet tip depth in the icon 114 of FIG. 67F can be used in another embodiment to indicate the confidence level of the stylet distal tip as determined by the system. These and other variations are therefore contemplated for the various elements and indicators of the icon 114.

[000244] FIGS. 68A-69 depict examples of other possible configurations for the icon 114 in depicting four and five-dimensional information, respectively, relating to: the three-dimensional position of the stylet distal tip; its orientation (*i.e.*, the fourth dimension); pitch, or angle of deviation of the stylet distal portion in the z-direction from the perspective of the x-y-z coordinate axis shown in FIG. 64, also referred to as a fifth dimension of stylet information, and indicating the angle at which the stylet distal end is approaching or departing from the sensor 50 (FIG. 64); and confidence level, *i.e.*, of the correctness of stylet position as determined by the system 10, also referred to herein as a sixth dimension of stylet information.

[000245] In FIGS. 68A and 68B, for example, the icon 114 includes the rod 1512 indicating stylet distal portion orientation, and the concentric circle array 1514 indicating stylet distal tip three-dimensional position and depth. In addition, a pitch indicator 1506 is included, implemented as a concentric circle array 1586 disposed at an end of the rod 1512 opposite the circle array 1514. The circle array 1586 includes concentric circles of a different color or

solidness from those of the circle array 1514. The circle array 1586 works in conjunction with the circle array 1514 to indicate stylet distal portion pitch. For instance, FIG. 68A depicts a situation where the stylet distal portion has a substantially zero pitch, i.e., a level attitude with respect to the sensor 50. In contrast, FIG. 68B depicts a situation where the stylet distal portion has a downward pitch, indicated by the relatively deeper position of the stylet distal tip (as indicated by the relatively fewer circles of the circle array 1514) with respect to the more shallow more proximal portion of the stylet distal portion (as indicated by the relatively greater number of circles in the circle array 1586). In this way, the icon 114 can indicate pitch to a system user.

[000246] FIG. 69 adds the above-mentioned sixth-dimensional confidence level to the embodiment of the icon 114 shown in FIGS. 68A and 68B by adding a confidence indicator 1508 thereto. In the present embodiment, the confidence indicator 1508 is implemented as a confidence bar graph 1588, wherein the number of bars present or solidly filled in indicate the level of confidence in the stylet distal position, orientation, etc., as determined by the system 10 (i.e., fewer bars indicating a lower level of confidence). Confidence described here is also referred to herein as "strength."

[000247] As such, it is appreciated that the icons described herein are only examples of various iconic indicators that can be employed to indicate positional and other characteristics of an indwelling device or component. Indeed, in other embodiments, other types of graphs, symbols, shapes, other indicators, and indicator configurations can be employed to represent the various characteristics of the stylet distal tip, including any one or more of the six dimensional characteristics described herein.

[000248] FIG. 71 depicts another example of the icon 114 in depicting five-dimensional stylet distal tip data according to one embodiment, wherein three dimensional stylet tip position and depth information is shown by the circle array 1514 of the icon, and the fourth-dimensional stylet distal portion orientation is shown by a rod 1592. In addition, the rod 1592 is given an angled perspective when depicted on the display 30 so as to visually indicate the pitch (i.e., the fifth dimension of stylet distal tip information) of the distal portion of the stylet. For instance, the angled rod 1592A indicates that the angle of the pitch is steeply positive, that is, the stylet tip is steeply approaching the sensor 50 in the z direction. Angled rods 1592B and 1592C also depict positive-pitch stylet tips, though at relatively less steep angles, as indicated in FIG. 71. The angled rod 1592D shows a zero pitch, while angled rods

1592E through 1592G depict negative-pitch stylet tips, i.e., the stylet distal portion is downwardly departing in the z direction from the sensor 50.

[000249] FIG. 72 depicts another example of the icon 114 in depicting a characteristic of the stylet distal tip, such as an uncertainty level regarding the position, orientation, etc., of the tip. As shown, the icon 114 includes the rod 1512 and a fixed tip icon 1510. The rod 1512, tip icon 1510, or both can fade in color, visibility, shading, etc. according to the level of uncertainty as determined by the system 10, shown to the right of the corresponding icons in FIG. 72. This is but one example of an additional characteristic that can be represented by the icon 114 when depicted on the system display 30. Thus, multiple aspects or pieces of information can be represented by one or more indicators of the icons as described herein. Note that as used herein, uncertainty is a value opposite to that of confidence, which is discussed above; the two terms are therefore inverses of one another, in one embodiment.

[000250] Note that the various indicators shown and described herein are depicted as integrated with or grouped physically proximate/adjacent to one another. In another embodiment, it is appreciated that the various aspects of the icons could be depicted separately from one another.

[000251] In FIG. 73, a screenshot 1600 of the system display 30 while the system is in the third modality referenced further above, i.e., ECG-based tip position confirmation, is shown. In particular, the icon 114 is shown, representing the distal catheter tip as it advances through the vasculature of the patient, superimposed upon the representative image 120 of the sensor 50 (FIG. 64). In accordance with one embodiment, the shape, color, etc., of the icon 114 can change according to the proximity of the tip to an intended intravascular location as determined or known by the system 10, such as the lower 1/3rd portion of the SVC. FIG. 73 shows that, before arriving at the intended destination, the icon 114 is similar to icons discussed above and includes the rod 1512 to indicate stylet distal tip orientation and the concentric circle array 1514 indicating the position and depth of the stylet tip. FIG. 74 shows that, once the system 10 has determined that the catheter distal tip has arrived at the lower 1/3rd portion of the SVC (or other suitable intended destination), a location indicator 1610 can be displayed, which in the present embodiment is implemented as a diamond 1620 that is superimposed on the rod 1512 and circle array 1514. In the present embodiment, the diamond 1620 is colored green, though other coloring, shading, and shapes can be used. This indicates to an observer that the catheter distal tip is correctly positioned.

[000252] FIG. 75 shows that, when the catheter distal tip has advanced past the intended destination, the location indicator 1610 can change to an octagon 1630 superimposed on the rod 1512 and circle array 1514, and which can be colored red. The shape and color of the icon location indicator 1610 here is suggestive of a "STOP" traffic sign to indicate to an observer that advancement of the catheter distal tip should stop and perhaps be retracted a suitable amount. In one embodiment, a gray circle or other suitable indicator can be superimposed on the icon 114 if insufficient data exists to depict the location indicator with a suitable level of confidence.

[000253] Note that the location indicators 1610 described in connection with FIGS. 73-75 include differing shapes in addition to the differing colors to enable differentiation even to color-blind observers or when printed out in black-and-white. Note also that the above-described icons are only representative of a wider range of possible icons that can be employed in indicating various aspects of the position, orientation, etc., of the indwelling device or component.

[000254] Generally, note that in other embodiments, the magnetic element(s) described above may vary from the design in not only shape, but also composition, number, size, magnetic type, and position in the stylet distal segment. For example, in one embodiment, the plurality of ferromagnetic magnetic elements is replaced with an electromagnetic assembly, such as an electromagnetic coil, which produces a magnetic field for detection by the sensor. Another example of an assembly usable here can be found in U.S. Patent No. 5,099,845 titled "Medical Instrument Location Means," which is incorporated herein by reference in its entirety. Yet other examples of stylets including magnetic elements that can be employed with the TLS modality can be found in U.S. Publication No. 2007/0049846 titled "Stylet Apparatuses and Methods of Manufacture," which is incorporated herein by reference in its entirety. These and other variations are therefore contemplated by embodiments of the present invention. It should be appreciated herein that "stylet" as used herein can include any one of a variety of devices configured for removable placement within a lumen of the catheter to assist in placing a distal end of the catheter in a desired location within the patient's vasculature, and can include guidewires. Additionally, it is appreciated that the catheter placement system described herein can take many forms and can include varying configurations from what is described herein. Further, the icons can be employed in describing aspects of indwelling medical devices other than stylets or be used with systems

that employ other modalities, including impedance-based systems, pressure-based systems, systems with varying different frames of reference (*e.g.*, from other than the TLS sensor's frame of reference), etc. Finally, it is appreciated that audio signals can accompany the depiction and movement of the icon on the display. For instance, in one embodiment a first audio tone can be sounded when the icon is near but not atop the sensor image 120 (FIGS. 73-75) such as is seen in FIG. 8B, a second audio tone when the icon is depicted in the top half of the sensor image such as in FIG. 73, a third tone when the icon is depicted in the middle portion of the sensor image such as in FIG. 74, and a fourth tone (such as a chirp) when the icon indicates that the stylet tip has passed the intended destination within the patient vasculature such as in FIG. 75. Note that the icons and tones described here are used in one embodiment to track the stylet distal tip using the ECG modality described further above. Thus, these and other audio-related icons are appreciated as falling within the present disclosure.

[000255] Embodiments of the present invention may comprise a special purpose or general-purpose computer including computer hardware. Embodiments within the scope of the present disclosure also include computer-readable media for carrying or having computer-executable instructions or data structures stored thereon. Such computer-readable media can be any available media that can be accessed by a general purpose or special purpose computer. By way of example, and not limitation, computer-readable media can include physical (or recordable-type) computer-readable storage media, such as, RAM, ROM, EEPROM, CD-ROM or other optical disk storage, magnetic disk storage or other magnetic storage devices, non-volatile and flash memory, or any other medium which can be used to store desired program code means in the form of computer-executable instructions or data structures and which can be accessed by a general purpose or special purpose computer.

[000256] In this description and in the following claims, a "network" is defined as one or more data links that enable the transport of electronic data between computer systems and/or modules. When information is transferred or provided over a network or another communications connection (either hardwired, wireless, or a combination of hardwired or wireless) to a computer, the computer properly views the connection as a computer-readable medium. Thus, by way of example, and not limitation, computer-readable media can also include a network or data links which can be used to carry or store desired program code

means in the form of computer-executable instructions or data structures and which can be accessed by a general purpose or special purpose computer.

[000257] Computer-executable instructions comprise, for example, instructions and data which cause a general purpose computer, special purpose computer, or special purpose processing device to perform a certain function or group of functions. The computer executable instructions may be, for example, binaries, intermediate format instructions such as assembly language, or even source code. Although the subject matter has been described in language specific to structural features and/or methodological acts, it is to be understood that the subject matter defined in the appended claims is not necessarily limited to the described features or acts described above. Rather, the described features and acts are disclosed as example forms of implementing the claims.

[000258] Those skilled in the art will appreciate that the embodiments of the present invention may be practiced in computing environments with one or more types of computer system configurations, including, personal computers, desktop computers, laptop computers, message processors, hand-held devices, multi-processor systems, microprocessor-based or programmable consumer electronics, network PCs, minicomputers, mainframe computers, mobile telephones, PDAs, pagers, and the like. Embodiments may also be practiced in distributed system environments where local and remote computer systems, which are linked (either by hardwired data links, wireless data links, or by a combination of hardwired and wireless data links) through a network, both perform tasks. In a distributed system environment, program modules may be located in both local and remote memory storage devices.

[000259] Embodiments of the invention may be embodied in other specific forms without departing from the spirit of the present disclosure. The described embodiments are to be considered in all respects only as illustrative, not restrictive. The scope of the embodiments is, therefore, indicated by the appended claims rather than by the foregoing description. All changes that come within the meaning and range of equivalency of the claims are to be embraced within their scope.

What is claimed is:

CLAIMS

1. In a system for guiding and placing a medical device within a body of a patient, the system including a display that depicts information relating to the medical device during insertion of the medical device into the body, an icon for depiction on the display, the icon comprising:

a position indicator that indicates a three-dimensional position of the medical device; and

at least one additional indicator included with the position indicator that indicates an additional aspect of the medical device.

2. The icon as defined in claim 1, wherein the medical device is inserted into a vasculature of the patient.

3. The icon as defined in claim 2, wherein the medical device includes a stylet, and wherein the position indicator indicates the position of a distal tip of the stylet.

4. The icon as defined in claim 1, wherein the medical device includes a catheter, and wherein the icon is related to the position of a distal tip of the catheter.

5. The icon as defined in claim 1, wherein the position indicator indicates the position of the medical device with respect to an x-y-z axis coordinate space.

6. The icon as defined in claim 5, wherein the position indicator includes a plurality of concentric circles, the number of circles depicted varying according to a depth of the medical device within the patient.

7. The icon as defined in claim 6, wherein the at least one additional indicator includes an orientation indicator that indicates an orientation of the medical device within the body of the patient.

8. The icon as defined in claim 7, wherein the orientation indicator includes a rod that is attached to the position indicator, a longitudinal extension of the rod indicating an orientation of a distal portion of the medical device.

9. The icon as defined in claim 1, wherein the at least one additional indicator includes a location indicator that indicates a proximity of the medical device to an intended destination within the patient body.

10. The icon as defined in claim 9, wherein the location indicator includes at least one of a diamond and an octagon.

11. The icon as defined in claim 10, wherein the diamond is colored green and wherein the octagon is colored red.

12. The icon as defined in claim 1, wherein the at least one additional indicator includes a pitch indicator that indicates a vertical pitch of the medical device within the body of the patient.

13. The icon as defined in claim 12, wherein the pitch indicator includes a rod that depicts an angle corresponding to an angled pitch of the medical device within the patient.

14. The icon as defined in claim 1, wherein the at least one additional indicator includes a confidence indicator that indicates a level of confidence determined by the system relating to at least the position of the medical device.

15. The icon as defined in claim 14, wherein the confidence indicator includes a bar graph.

16. The icon as defined in claim 1, wherein the at least one additional indicator includes an uncertainty indicator that indicates a level of uncertainty determined by the system relating to at least the position of the medical device.

17. The icon as defined in claim 1, wherein the icon relates to detection by the system of a magnetic element of the medical device.

18. The icon as defined in claim 1, wherein the icon relates to detection by the system of an ECG signal of the patient.

19. A method for placing a catheter within a vasculature of a patient, the method comprising:

introducing the catheter into the vasculature of the patient, the catheter including a stylet;
detecting a field of at least one magnetic element of the stylet when the catheter is within the vasculature of the patient; and
depicting on a display an icon relating to the stylet, the icon comprising:
a position indicator that indicates a three-dimensional position of a distal end of the stylet; and
at least one additional indicator included with the position indicator that indicates an additional aspect of the stylet.

20. The method for placing the catheter as defined in claim 19, wherein depicting on the display further comprises depicting on the display the icon, wherein the at least one additional indicator includes an orientation indicator that indicates an orientation of the stylet within the body of the patient.

21. The method for placing the catheter as defined in claim 19, wherein depicting on the display further comprises depicting on the display the icon, wherein the at least one additional indicator includes a confidence indicator that indicates a confidence level relating to the actual position of the distal end of the stylet within the vasculature.

22. In a system for guiding and placing a catheter within a body of a patient, the system including a display that depicts information relating to the catheter during insertion of the catheter into the body, an icon for depiction on the display, the icon comprising:

a position indicator that visually represents a three-dimensional position relating to the catheter; and
an orientation indicator included with the position indicator that visually represents an orientation relating to a distal portion of the catheter.

23. The icon as defined in claim 22, wherein the catheter includes a stylet, and wherein the position and orientation indicators indicate the position and orientation of a distal portion of the stylet, a distal tip of the stylet being substantially co-terminal with a distal tip of the catheter.

24. The icon as defined in claim 23, wherein the position indicator includes a plurality of concentric circles, the number of circles depicted varying according to a depth of the medical device within the patient.

25. The icon as defined in claim 24, wherein the orientation indicator includes a rod that is attached to the position indicator, a longitudinal extension of the rod indicating an orientation of a distal portion of the medical device.

26. The icon as defined in claim 22, further comprising a location indicator included with the position and orientation indicators, the location indicator indicating a proximity of the distal tip of the stylet to an intended destination within the patient body.

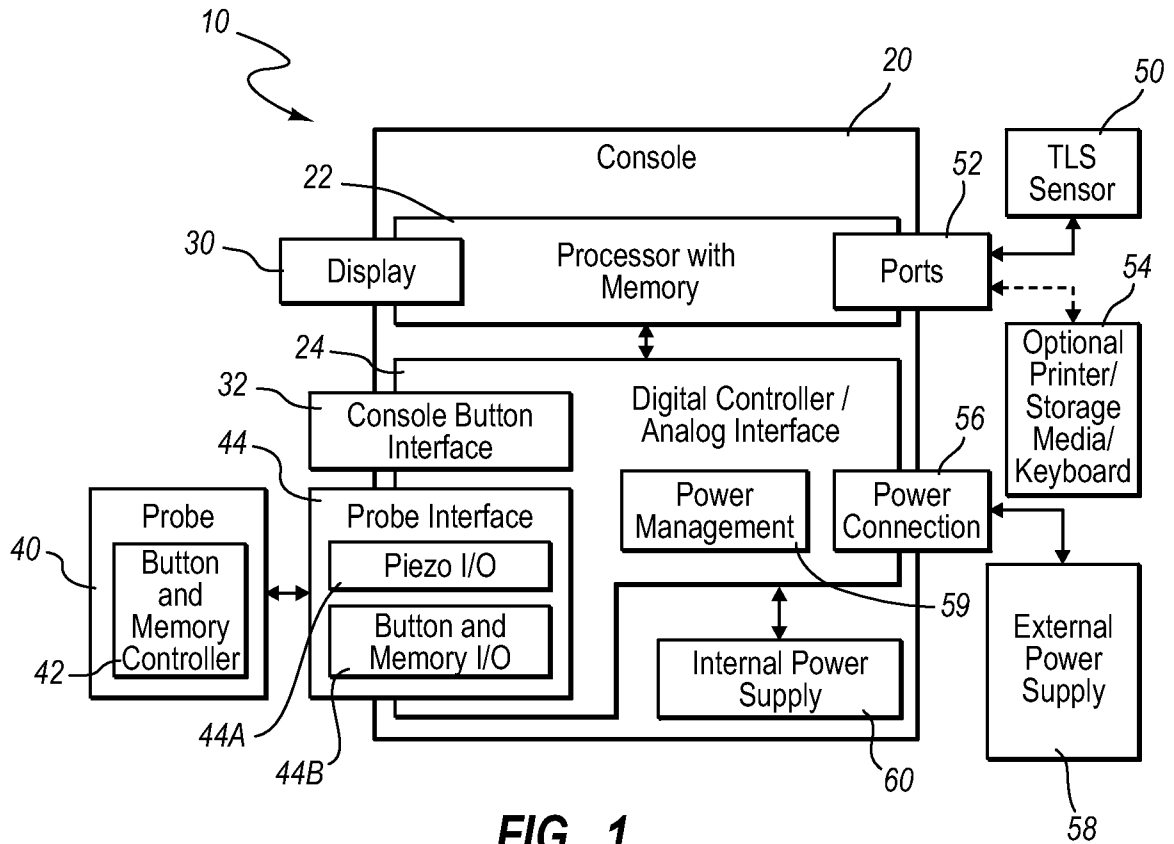

FIG. 1

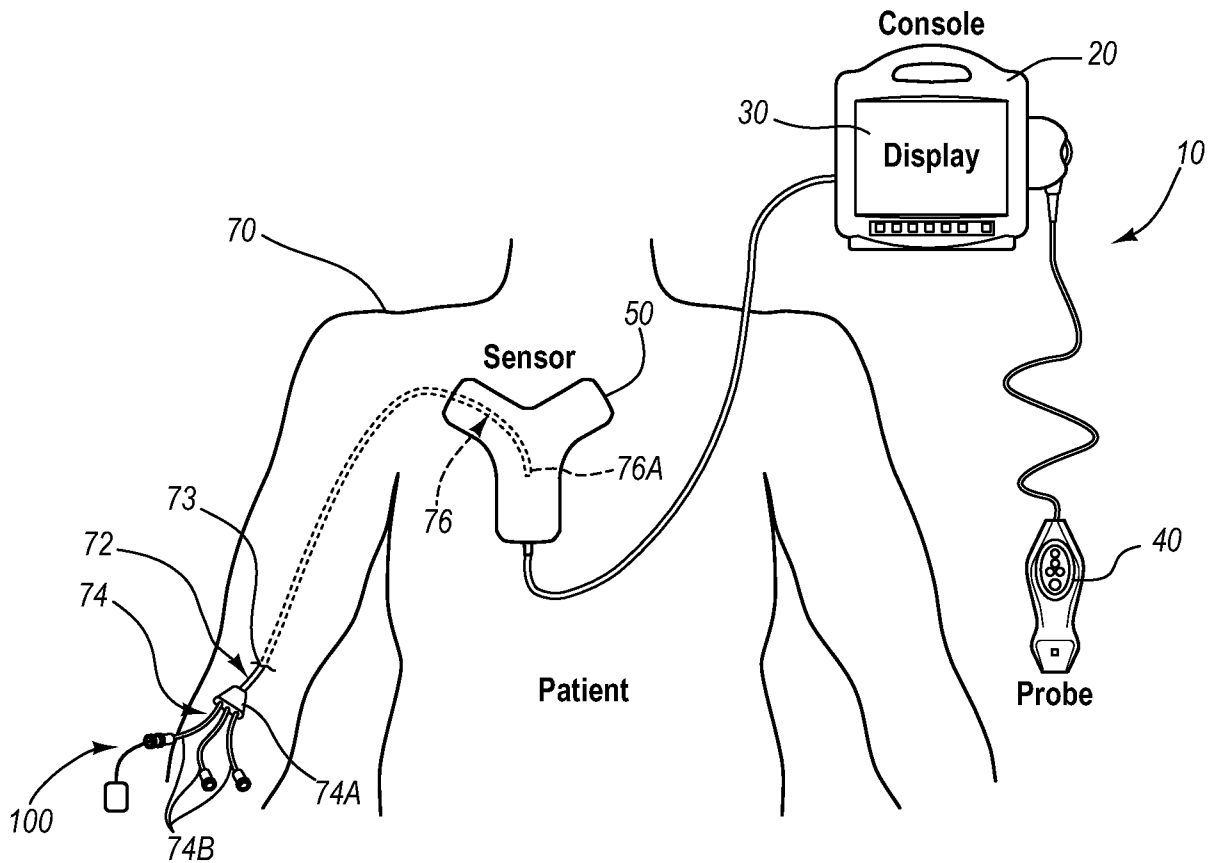

FIG. 2

2/57

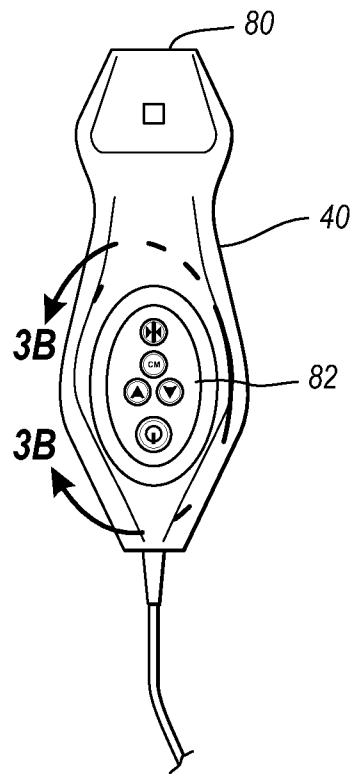

FIG. 3A

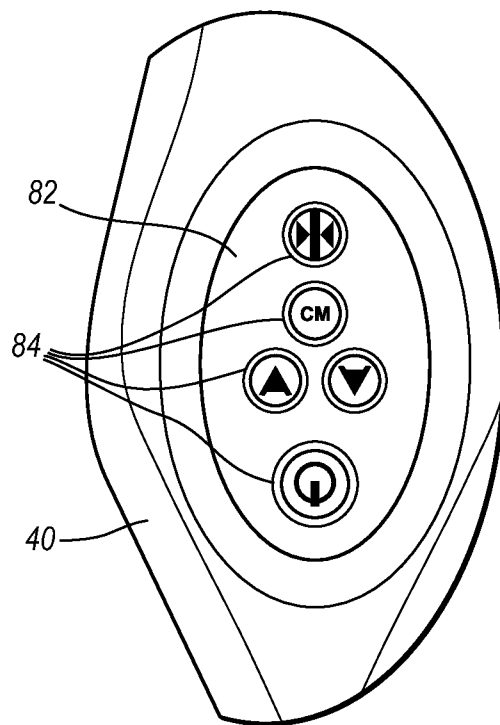

FIG. 3B

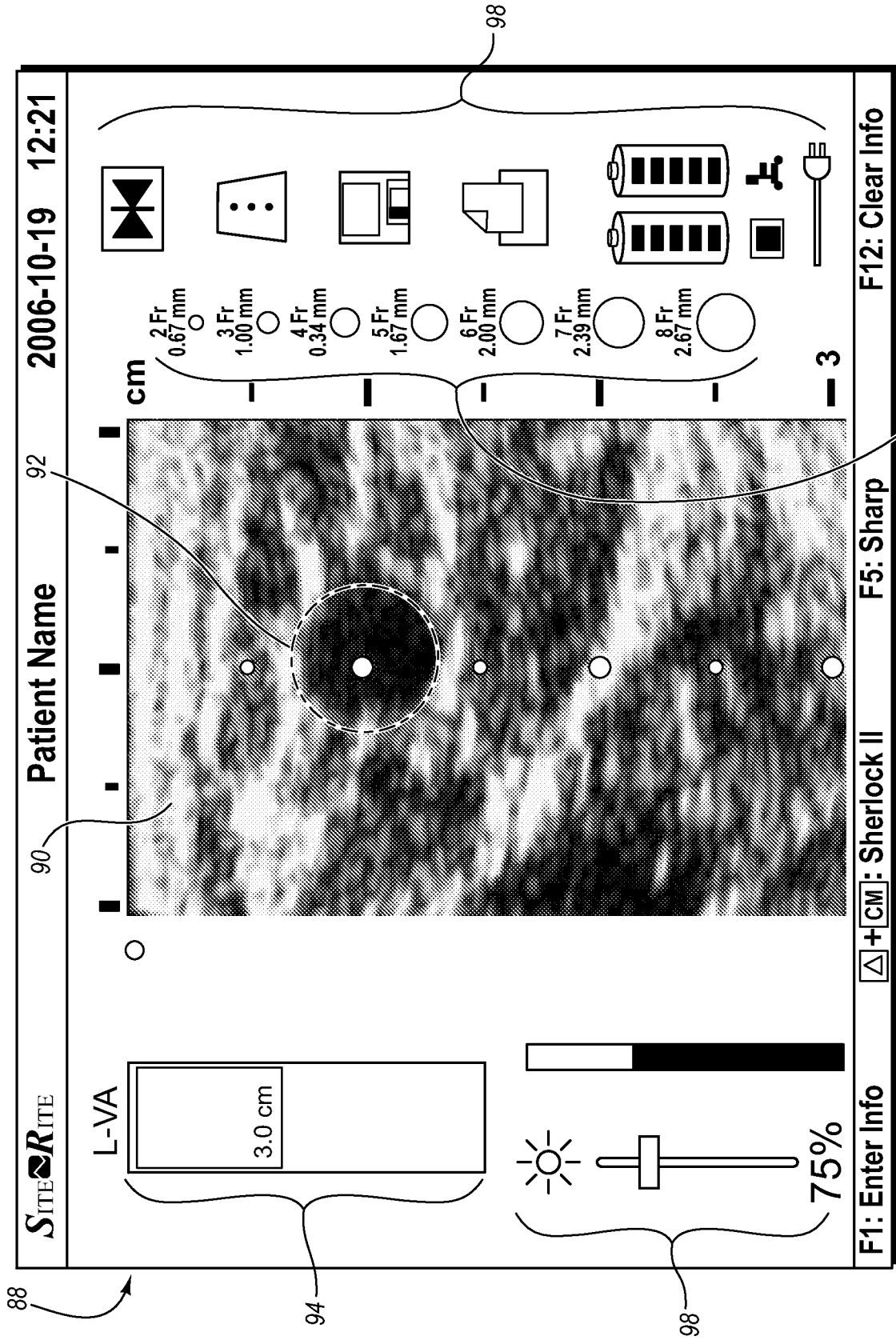

FIG. 4

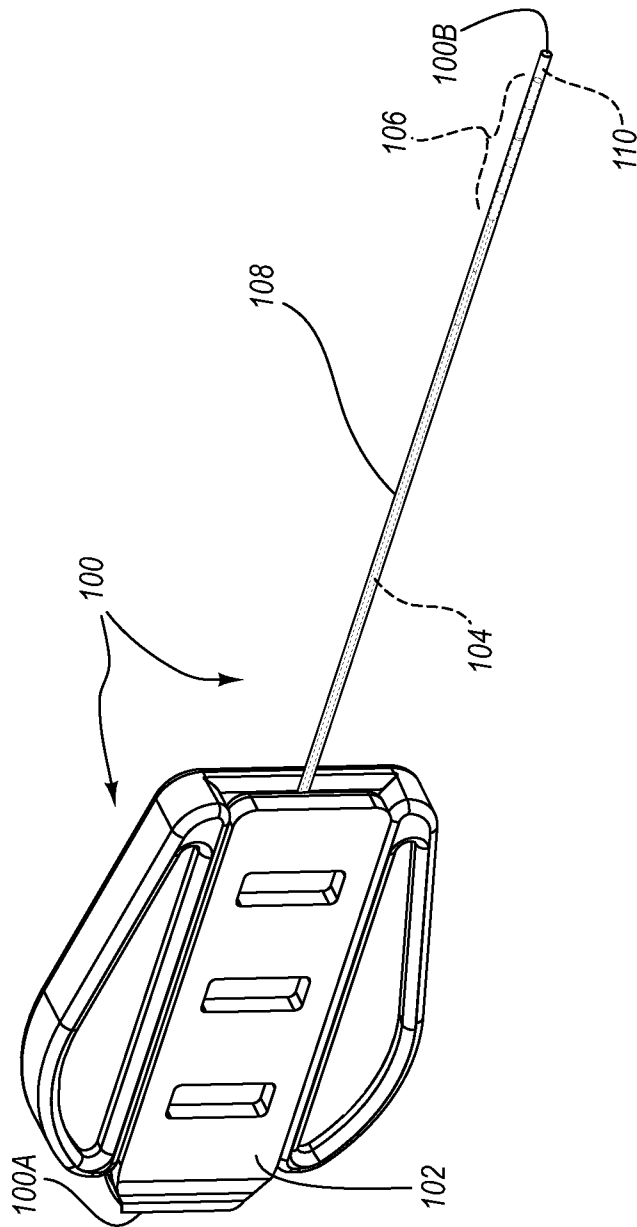

FIG. 5

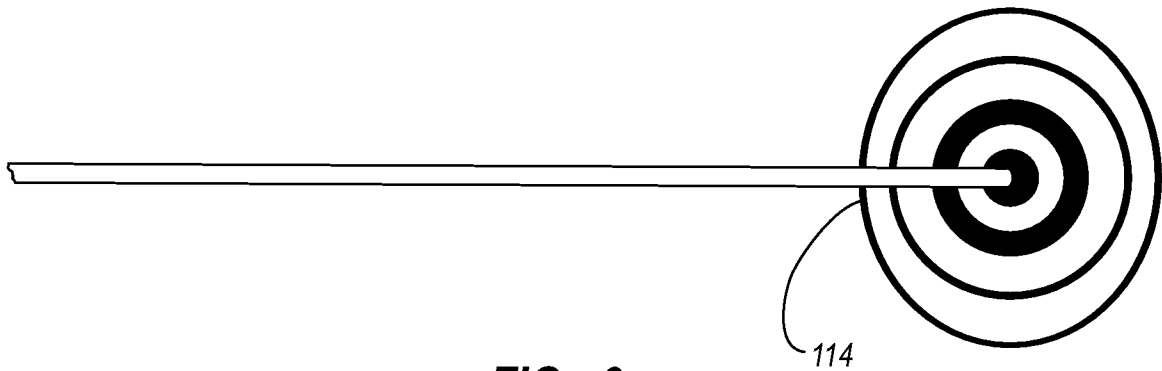

FIG. 6

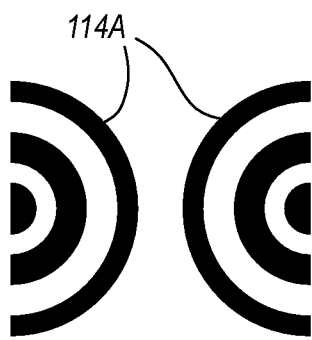

FIG. 7A

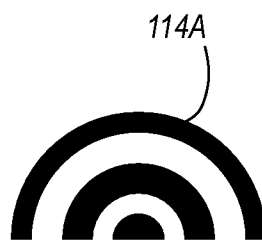

FIG. 7B



FIG. 7C

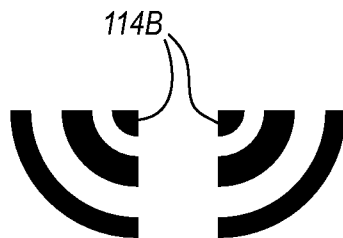

FIG. 7D

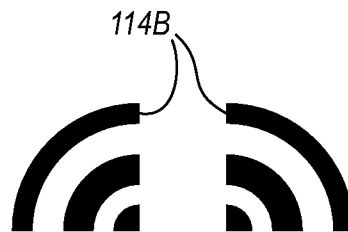

FIG. 7E

6/57

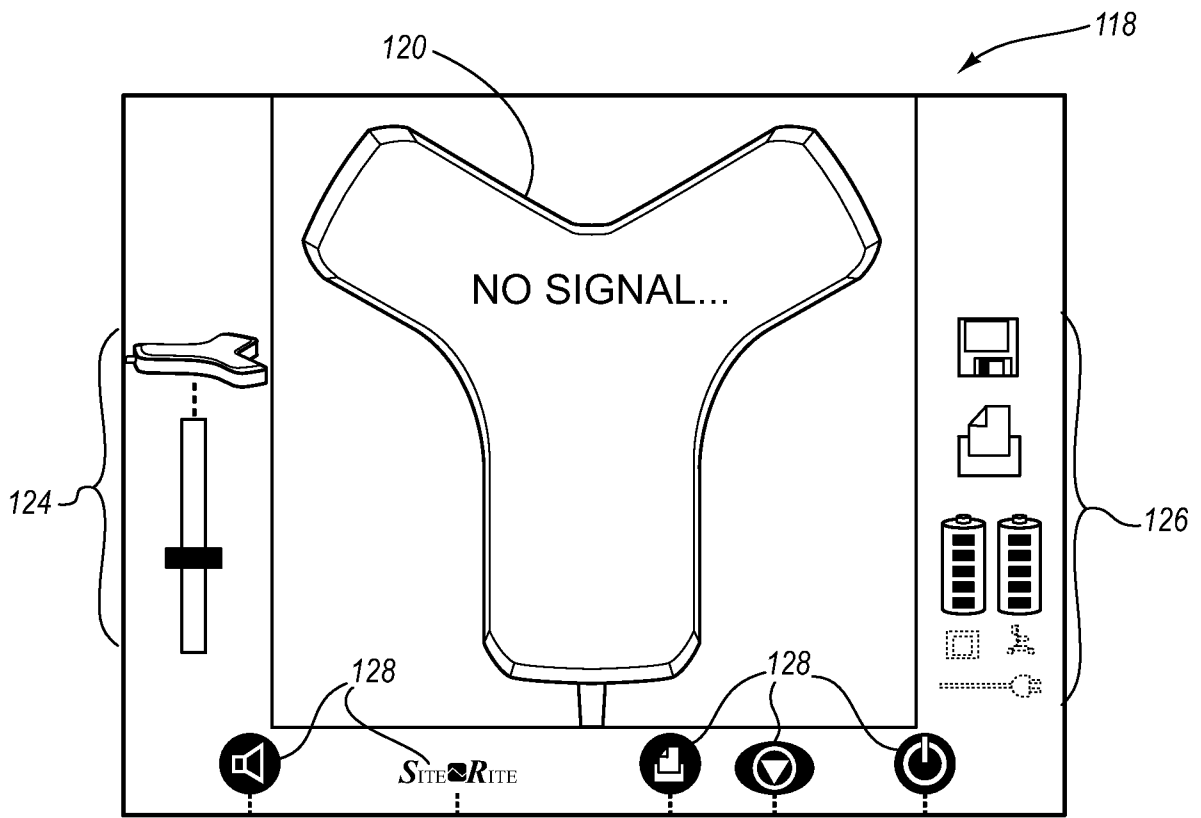

FIG. 8A

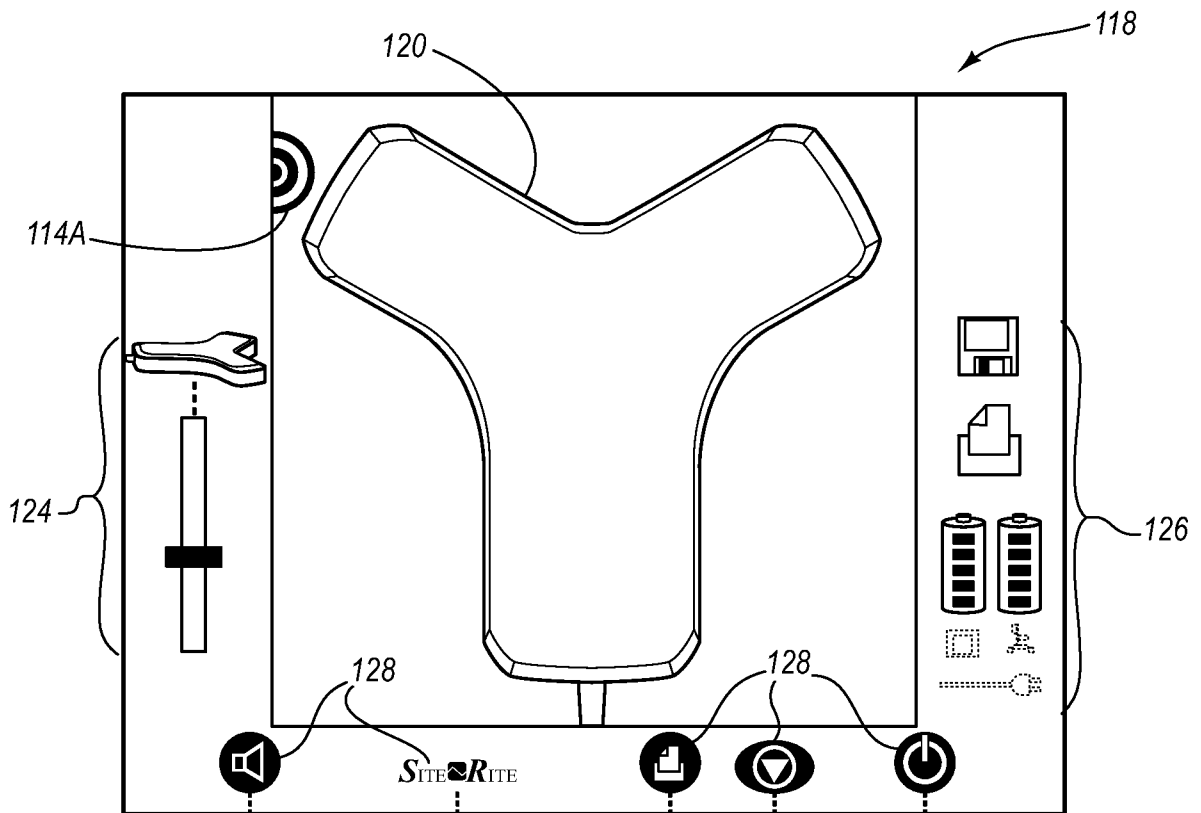

FIG. 8B

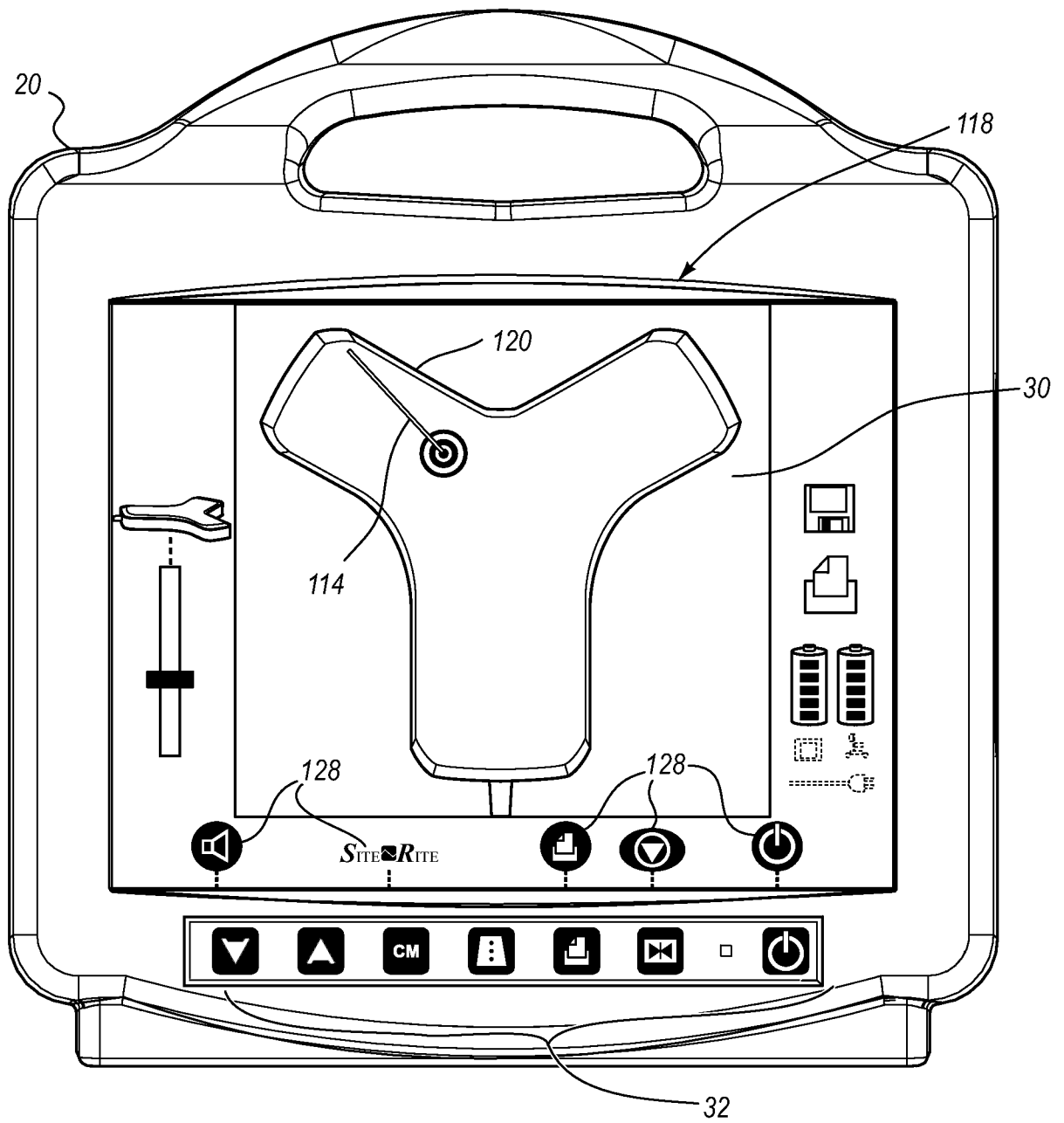

FIG. 8C

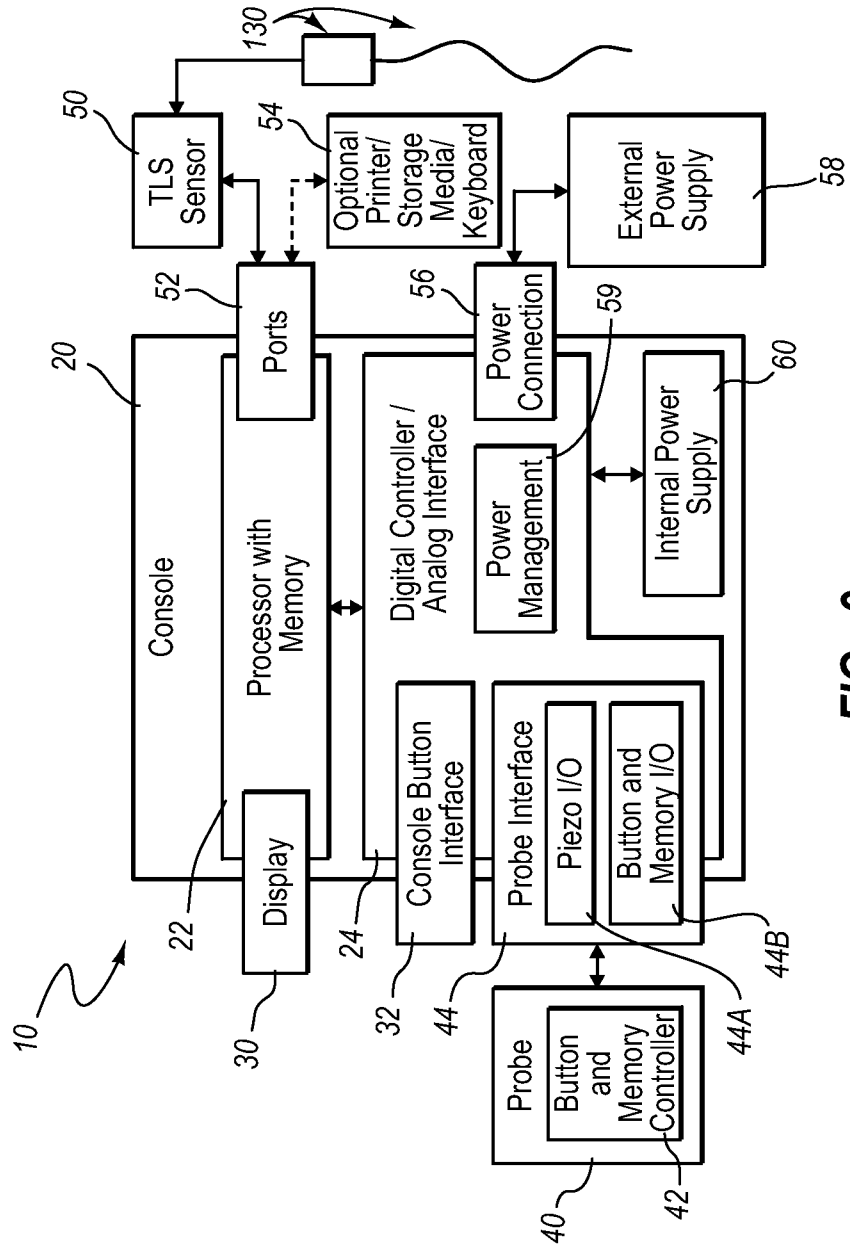

FIG. 9

9/57

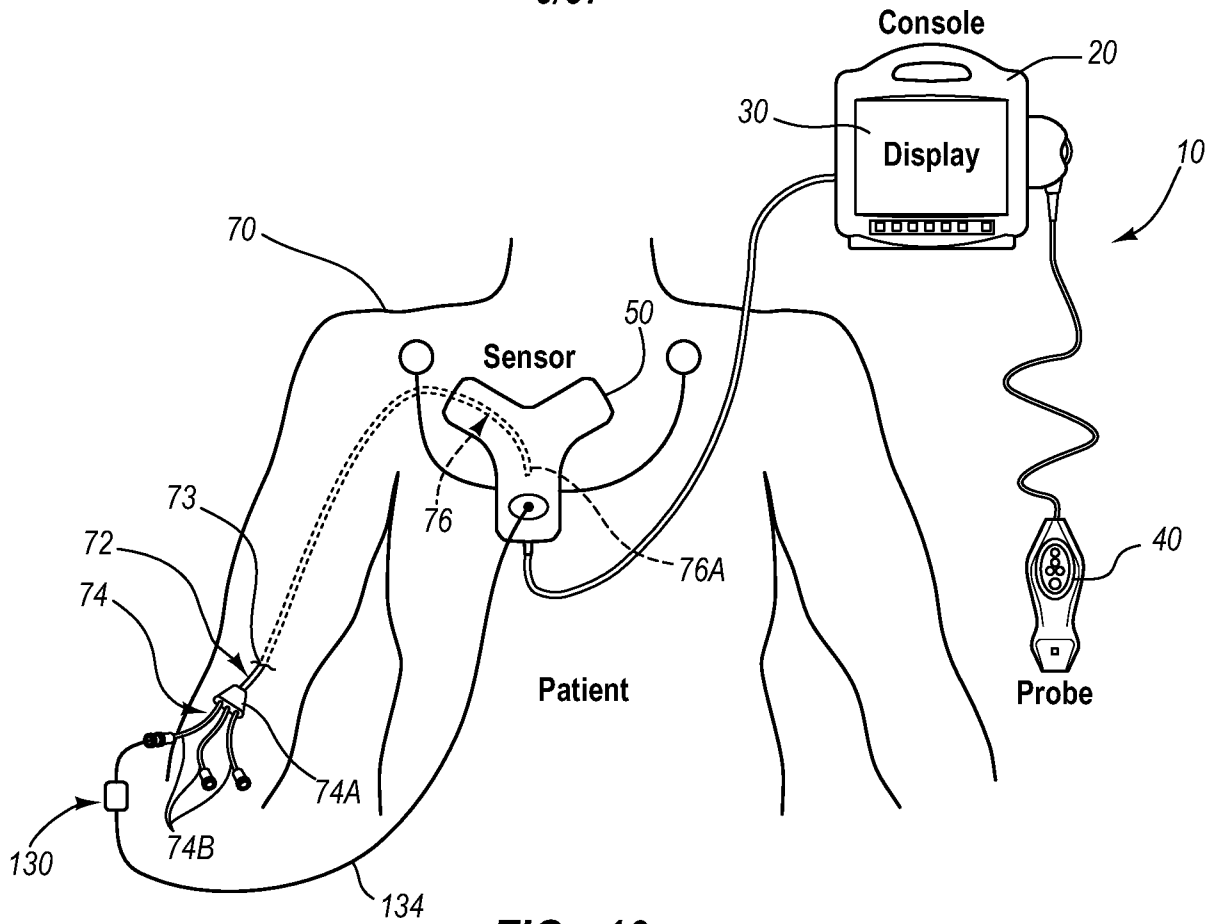

FIG. 10

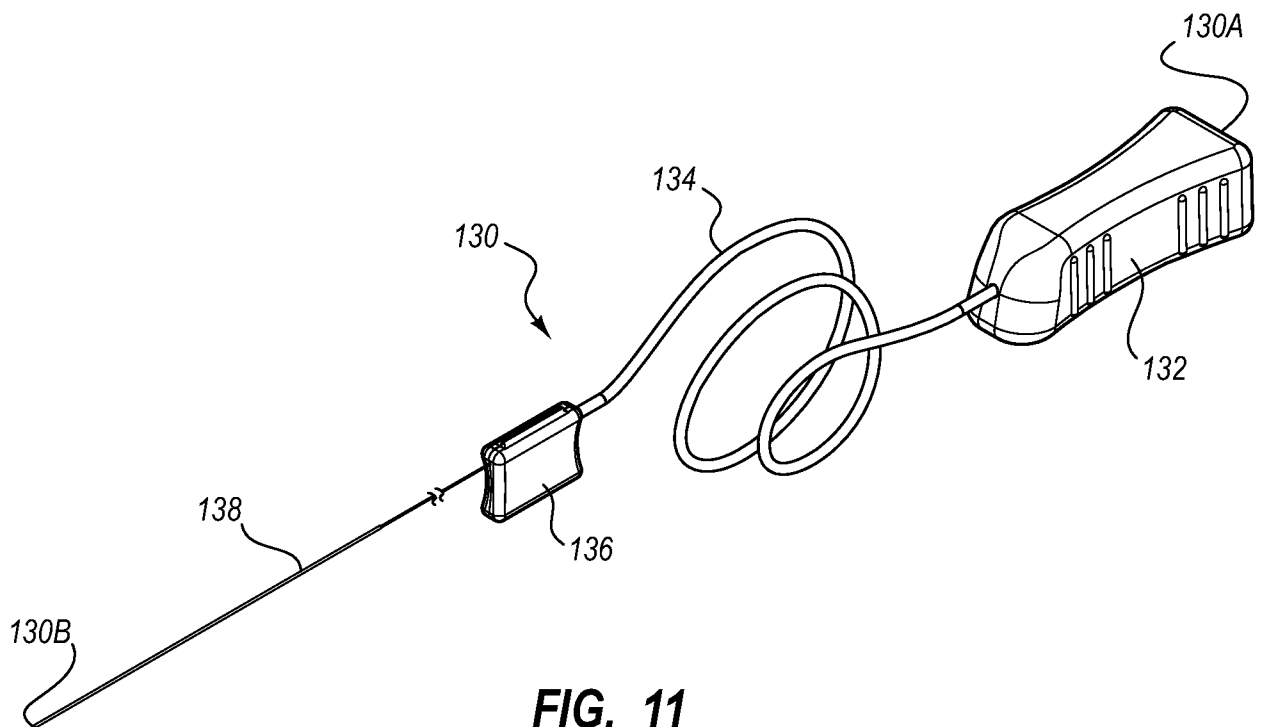

FIG. 11

10/57

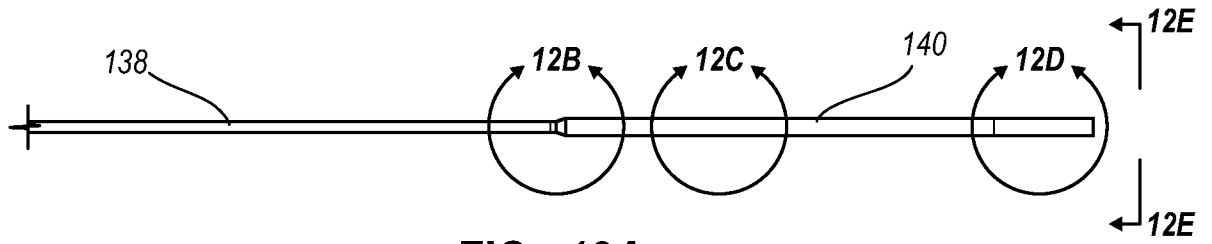

FIG. 12A

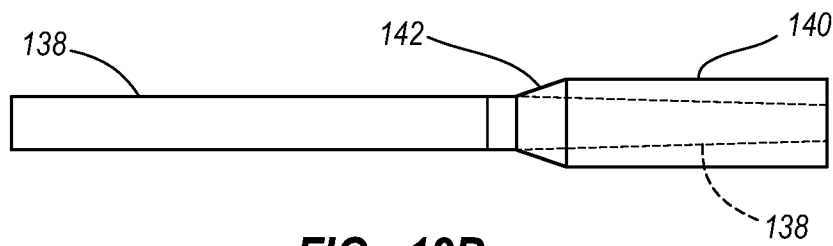

FIG. 12B

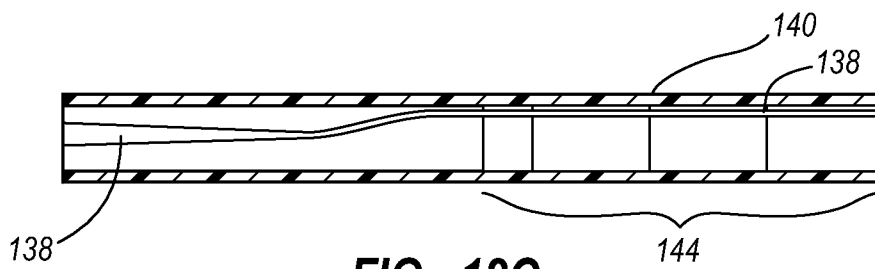

FIG. 12C

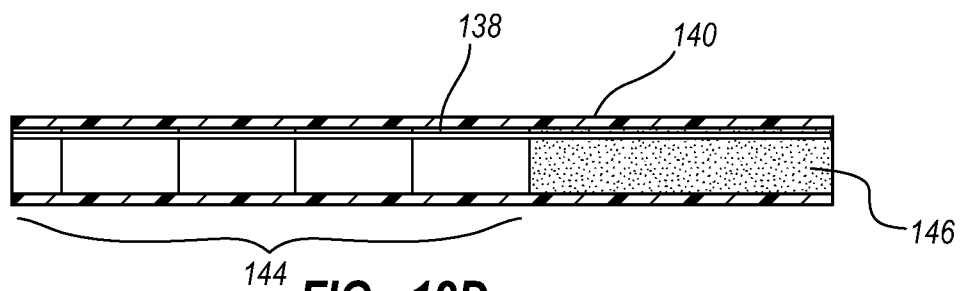

FIG. 12D

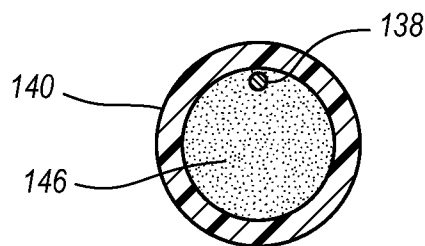

FIG. 12E

11/57

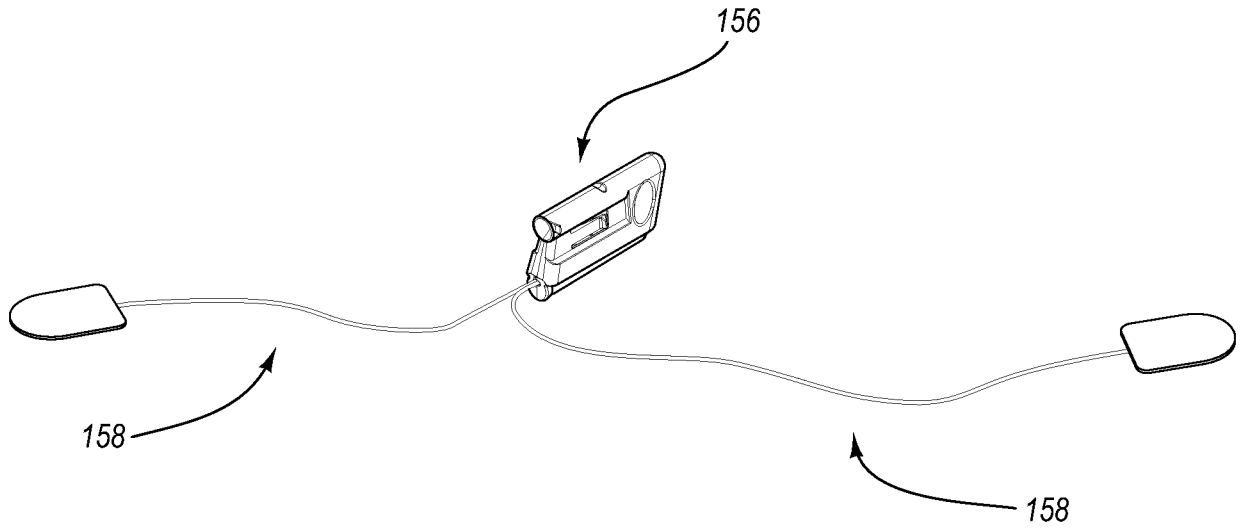

FIG. 13A

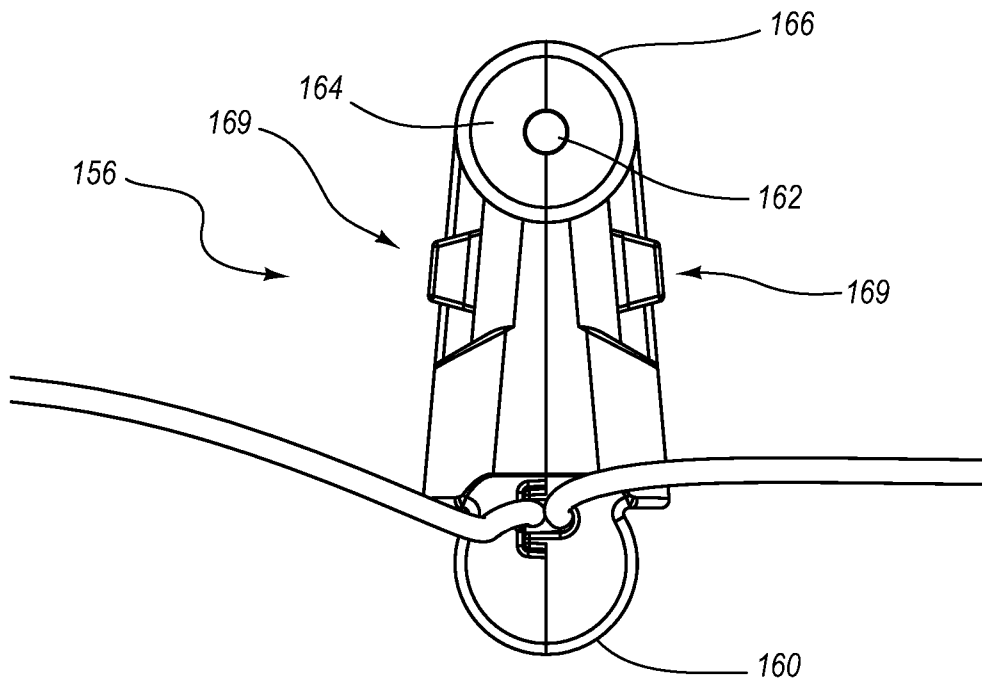

FIG. 13B

12/57

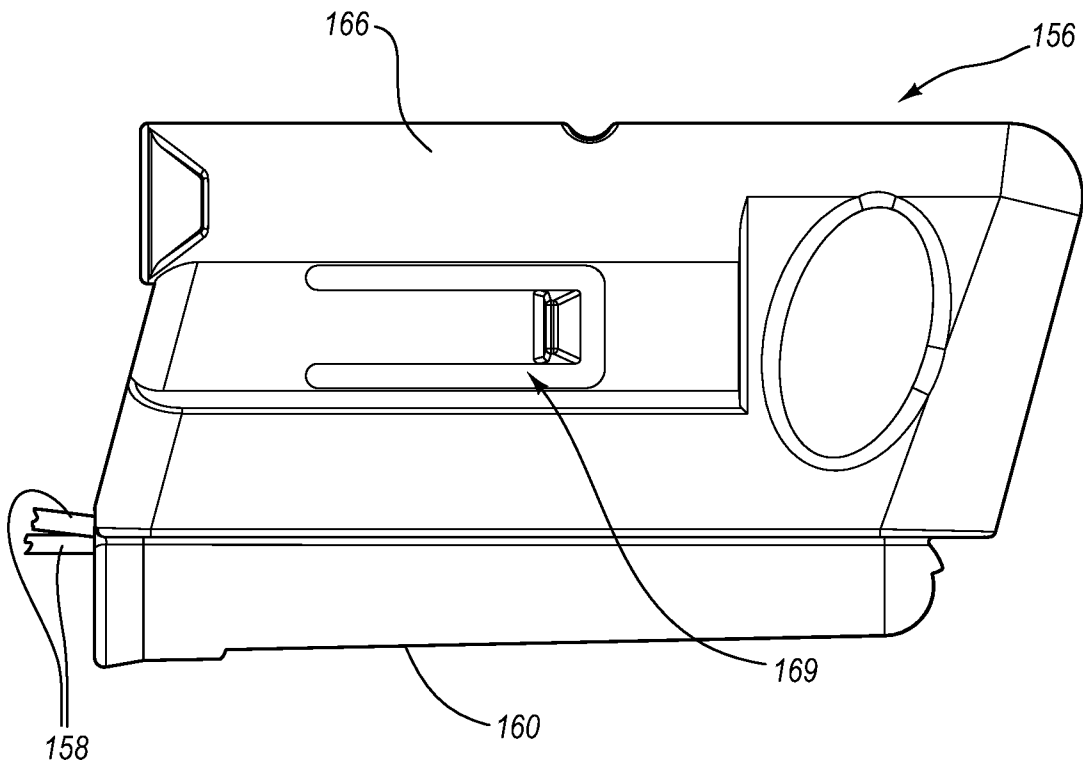

FIG. 13C

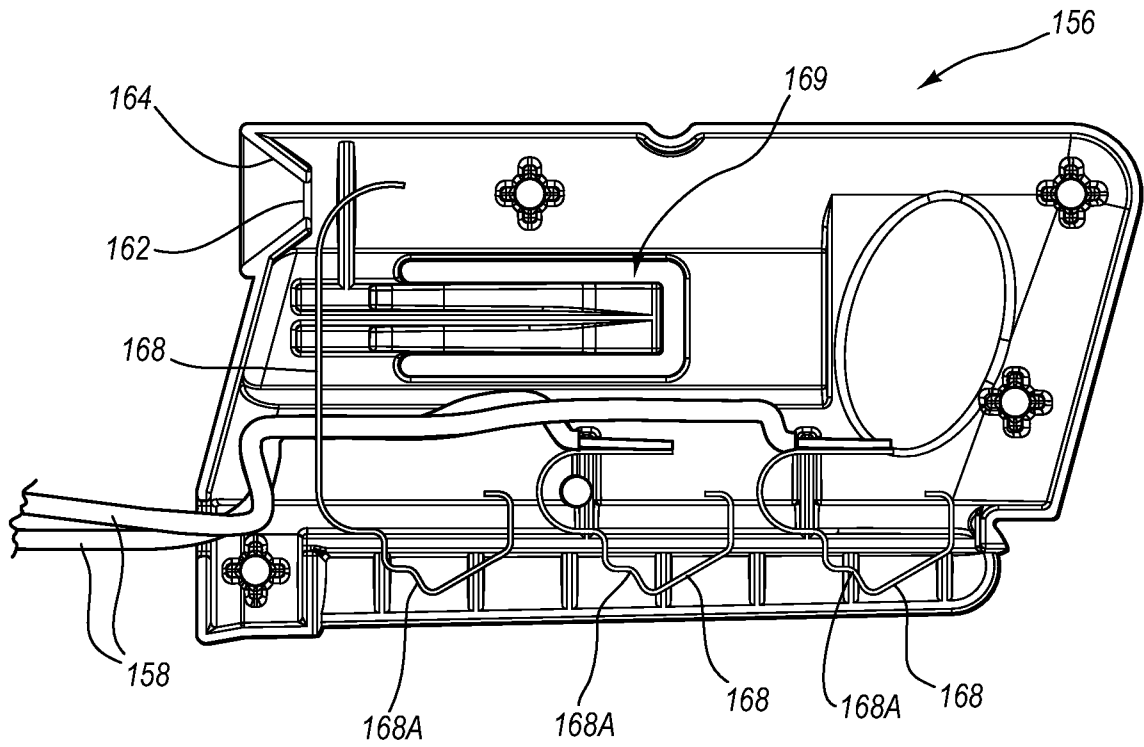

FIG. 13D

13/57

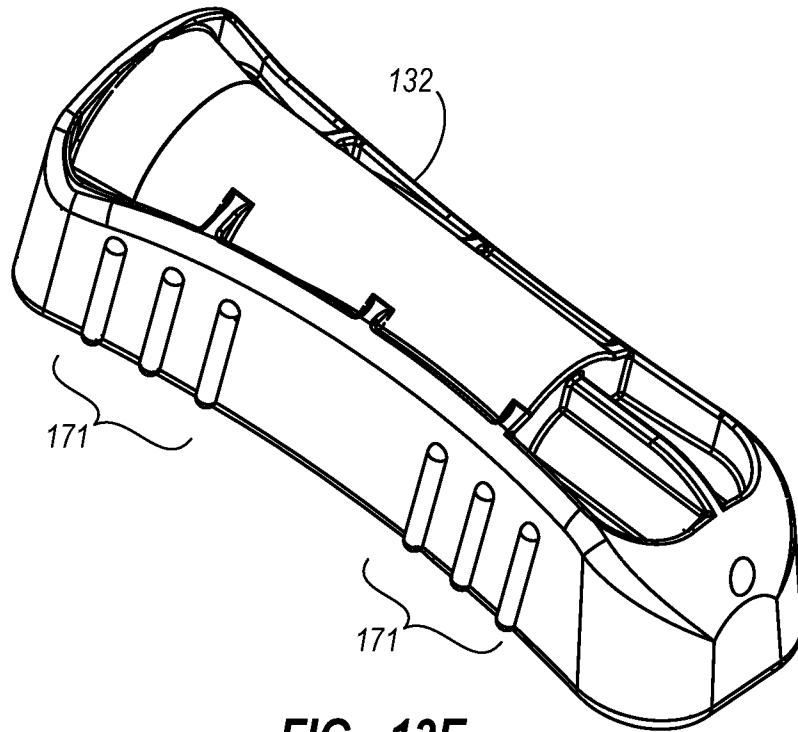

FIG. 13E

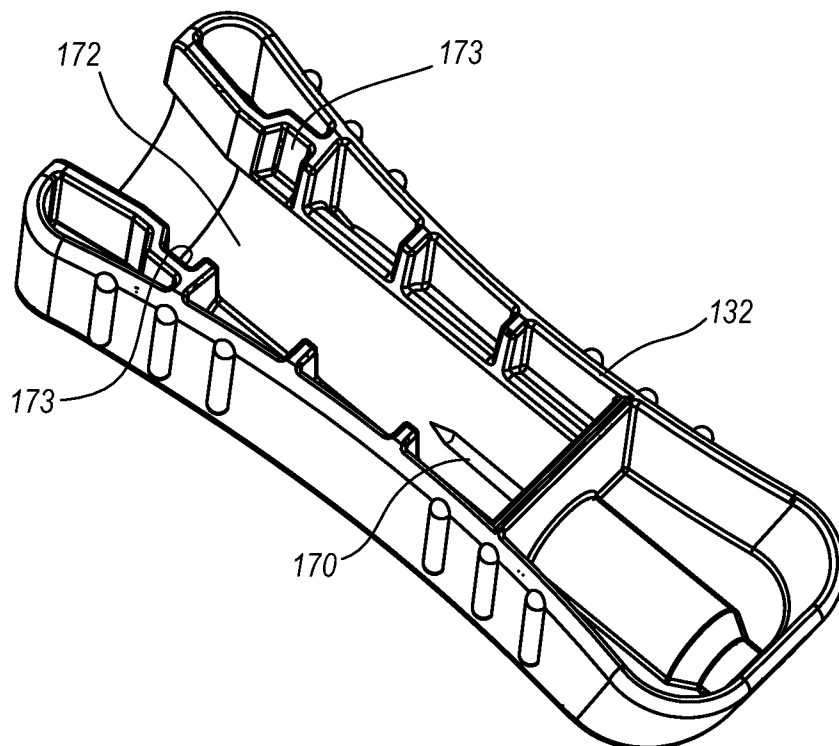

FIG. 13F

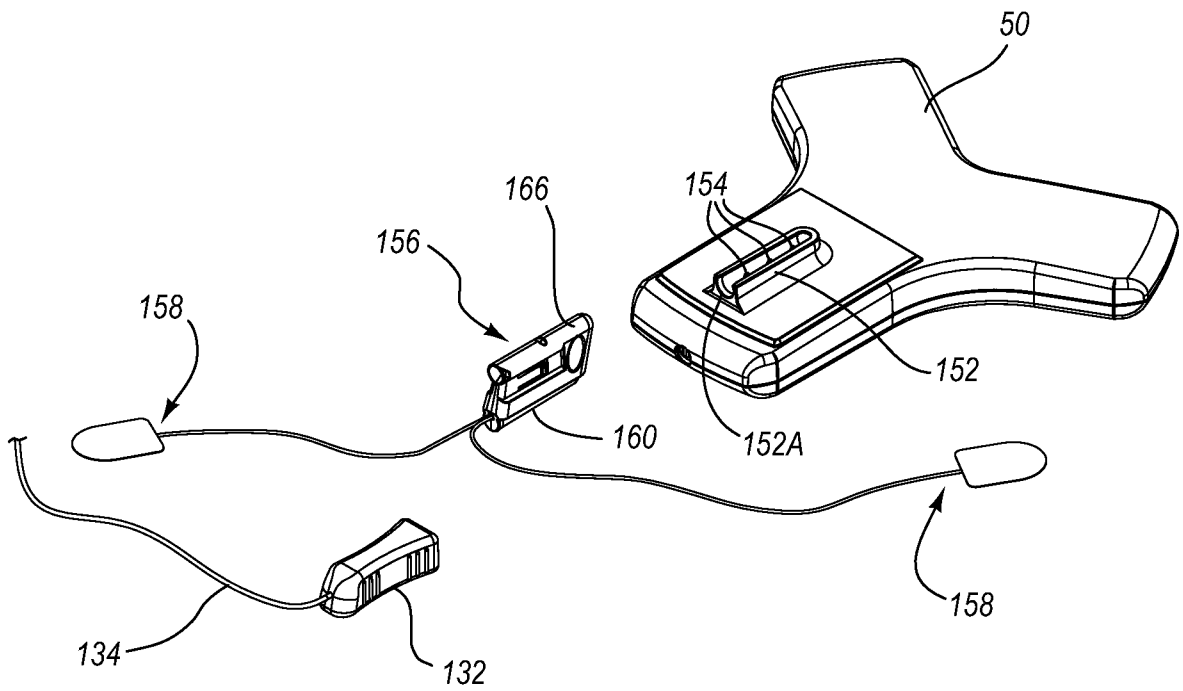

FIG. 14A

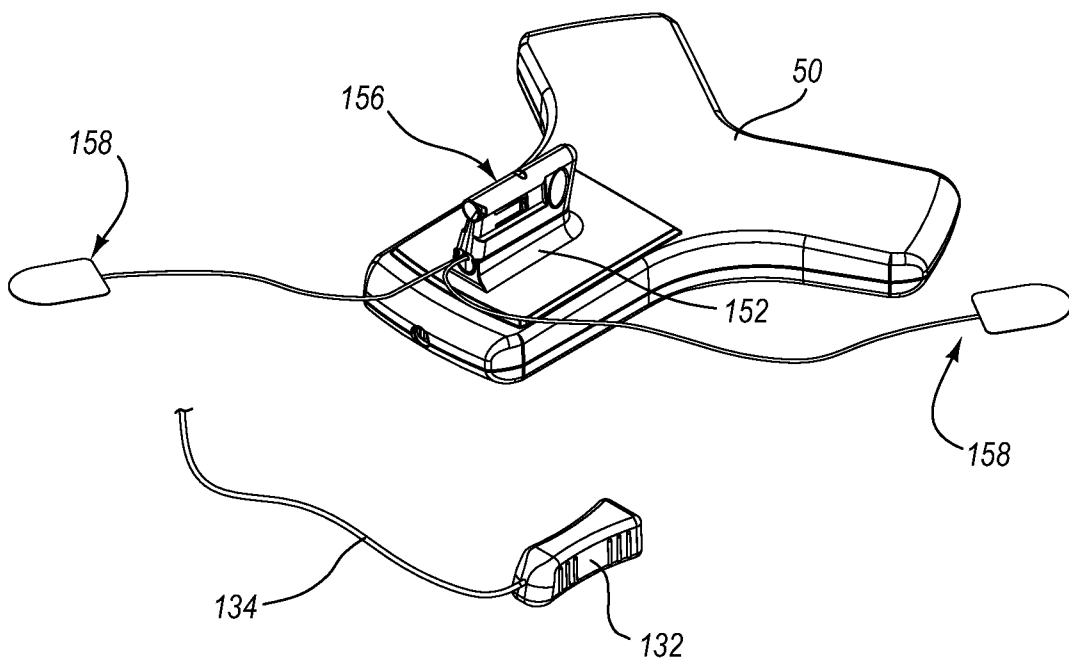

FIG. 14B

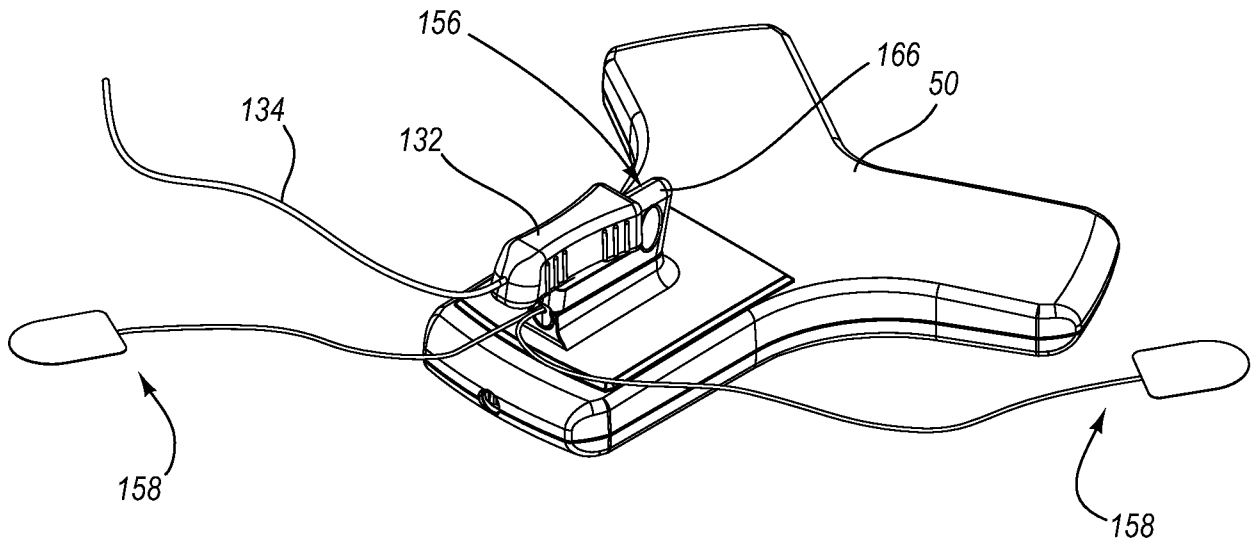

FIG. 14C

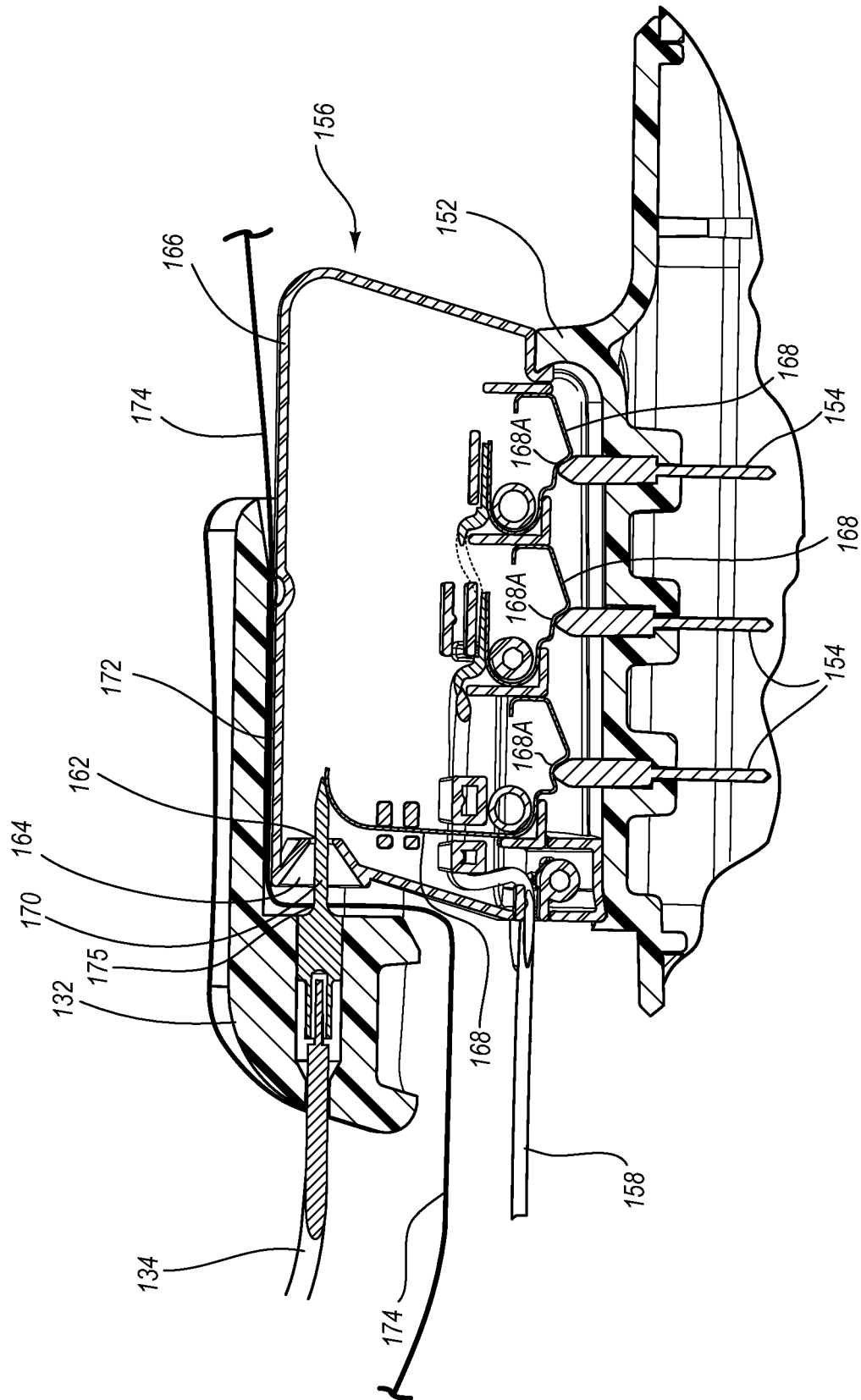

FIG. 15

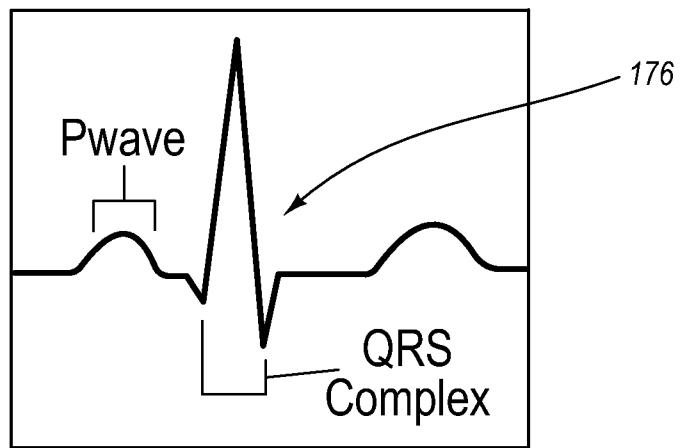

FIG. 16

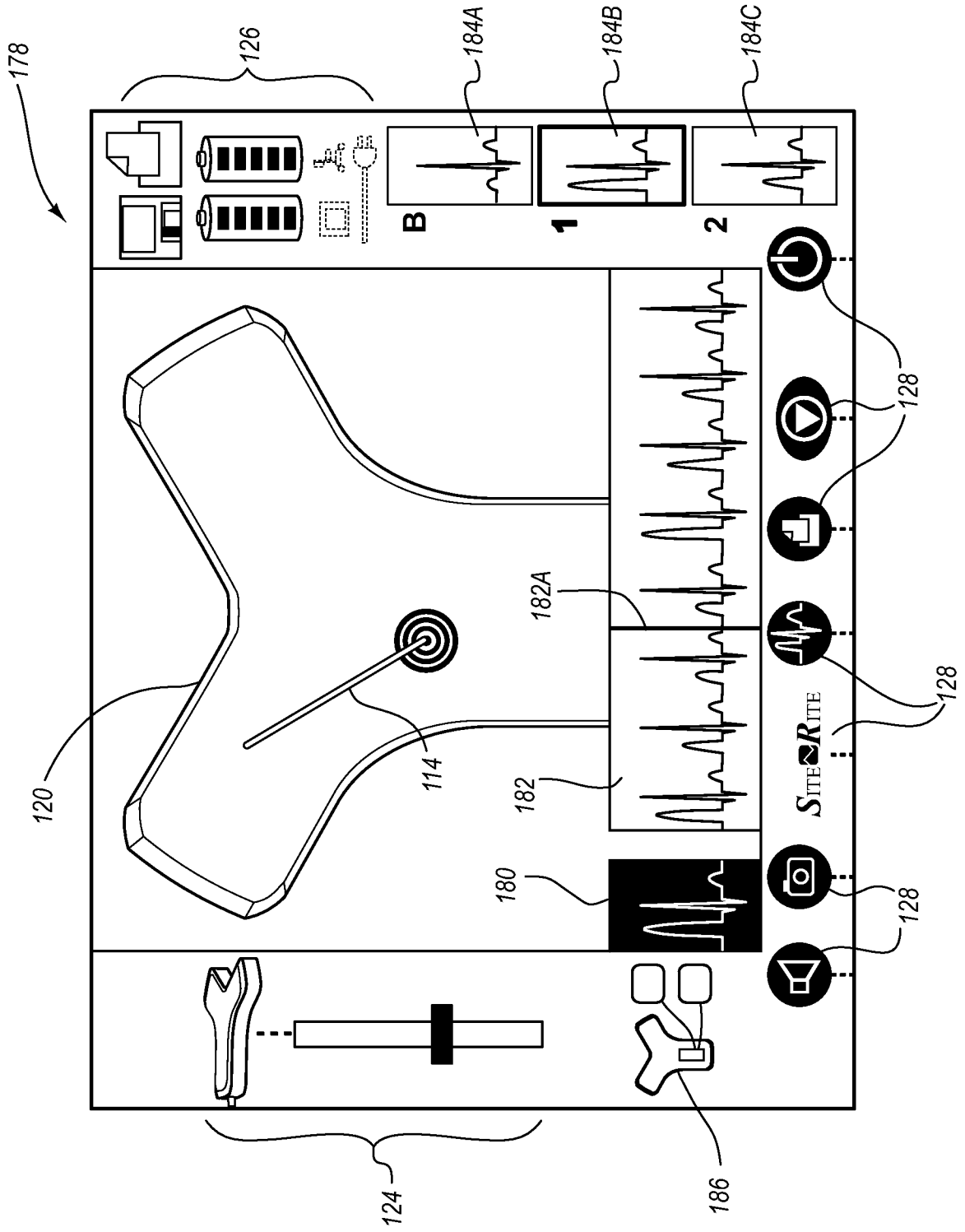

FIG. 17

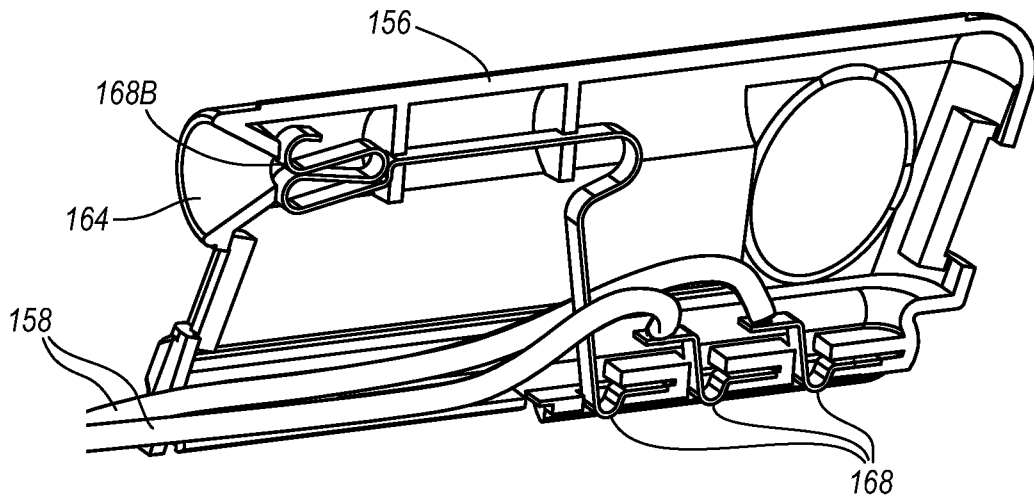

FIG. 18

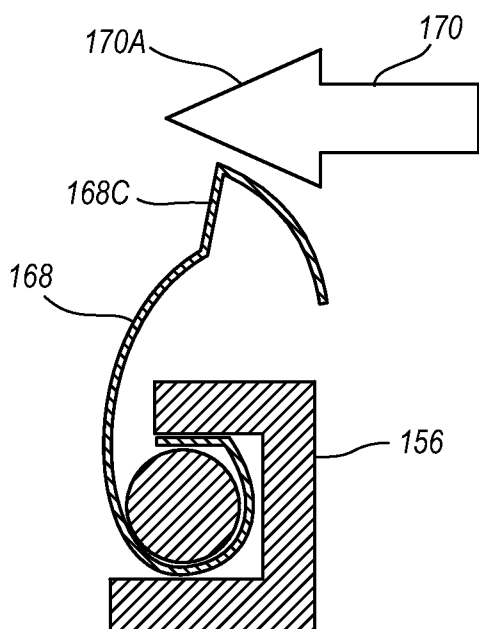

FIG. 19A

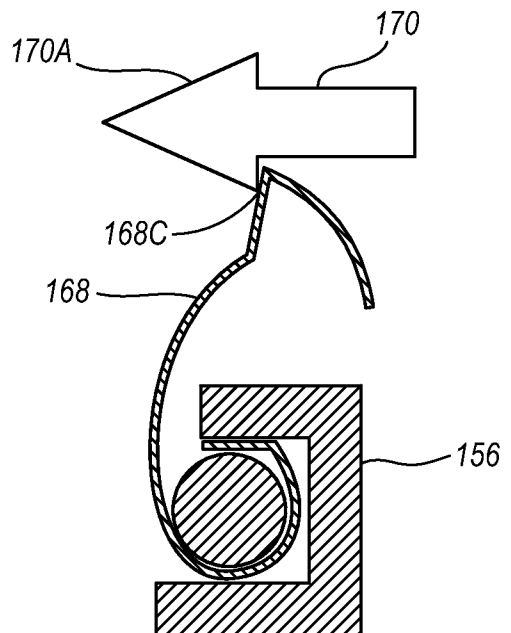

FIG. 19B

20/57

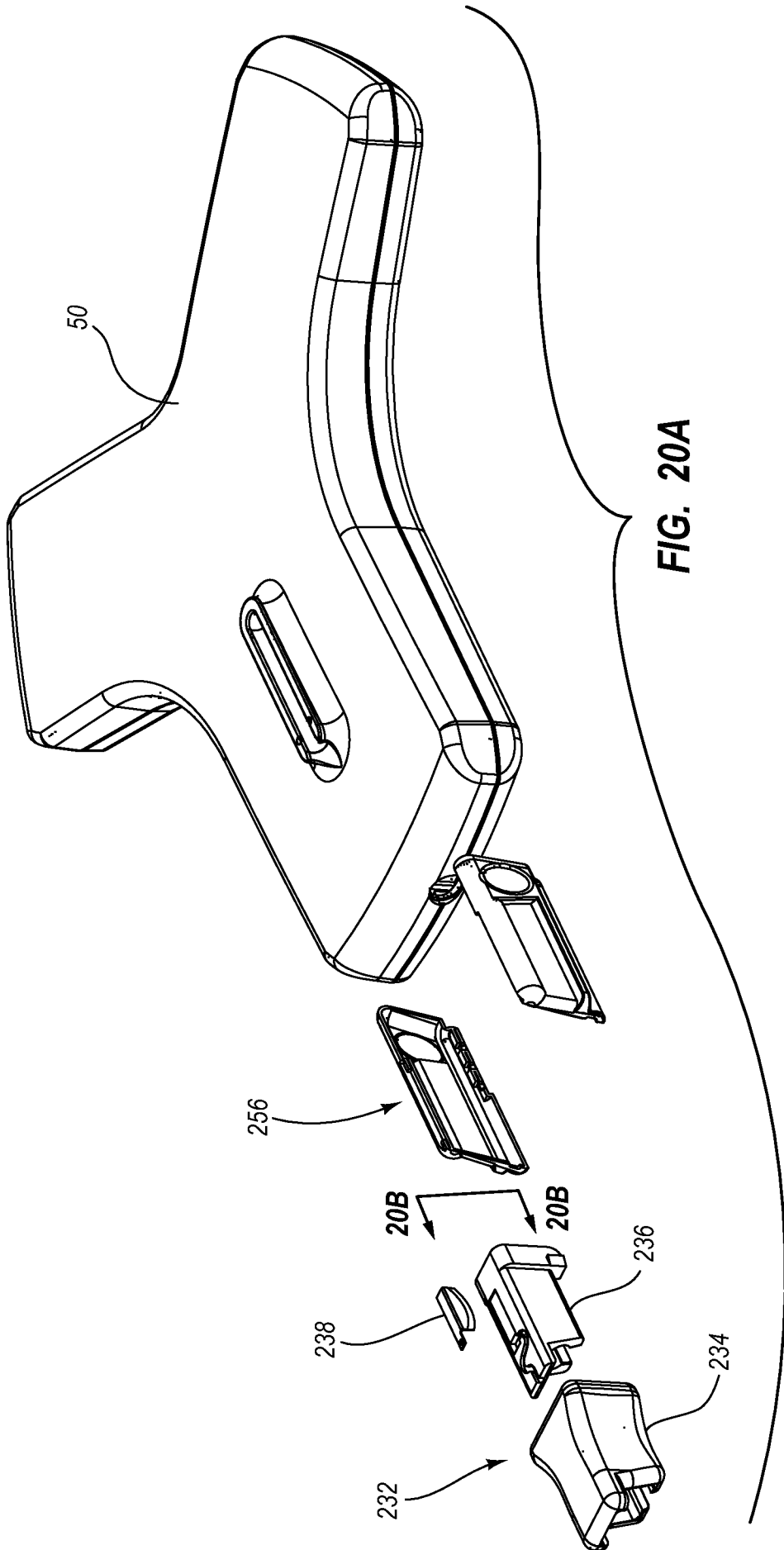

FIG. 20A

21/57

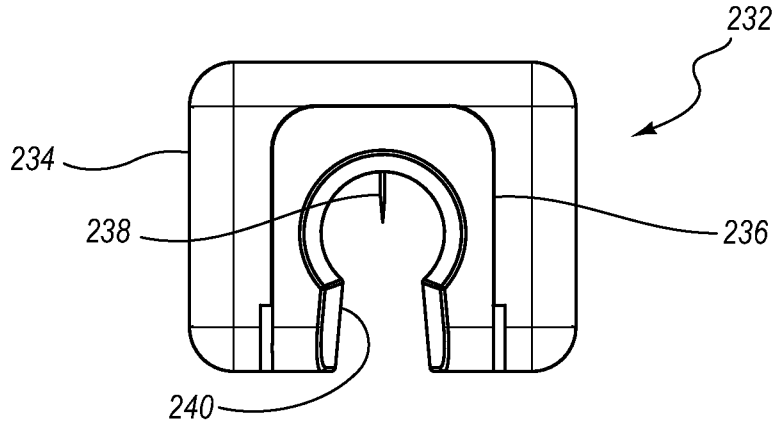

FIG. 20B

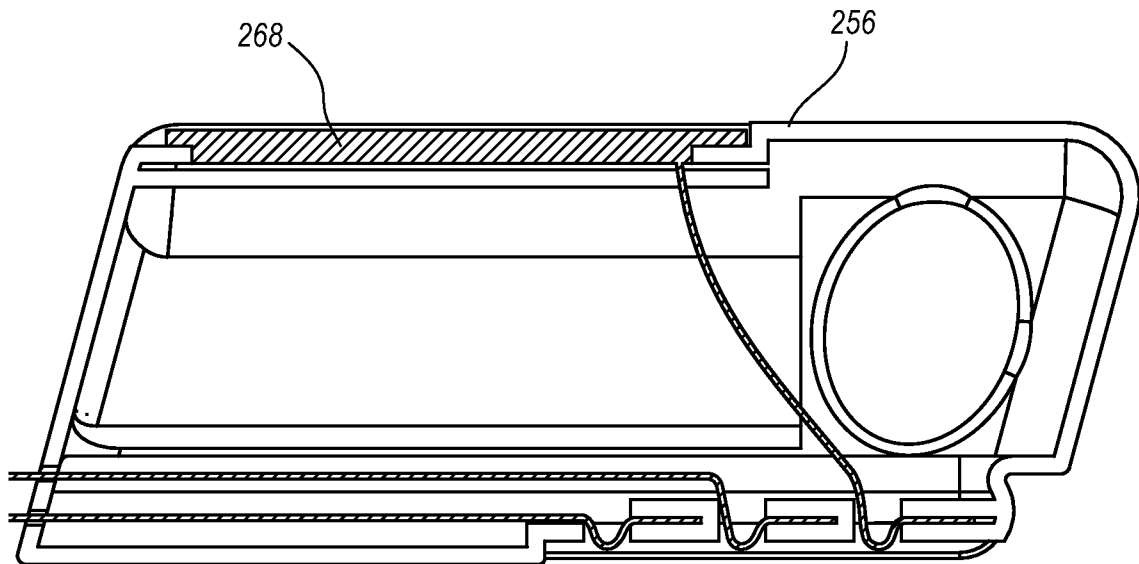
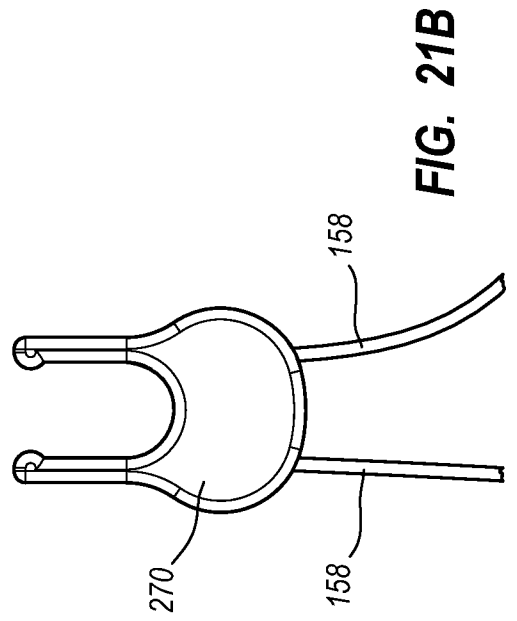
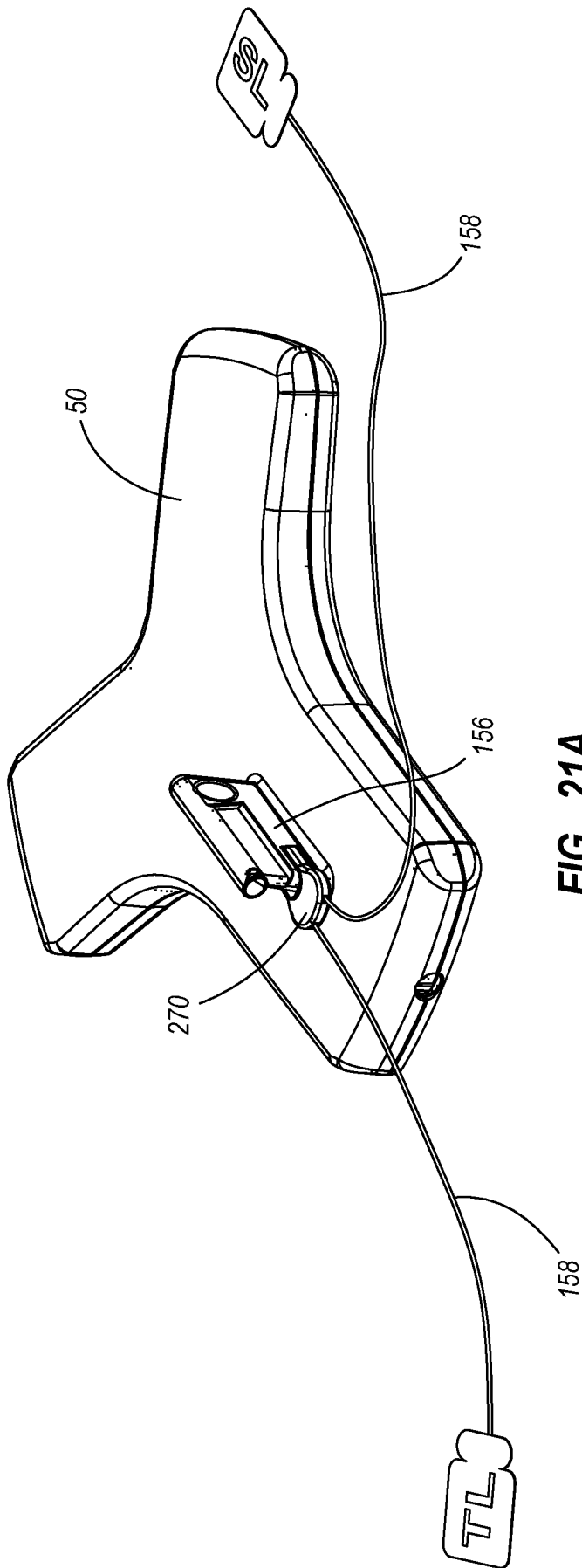

FIG. 20C



23/57

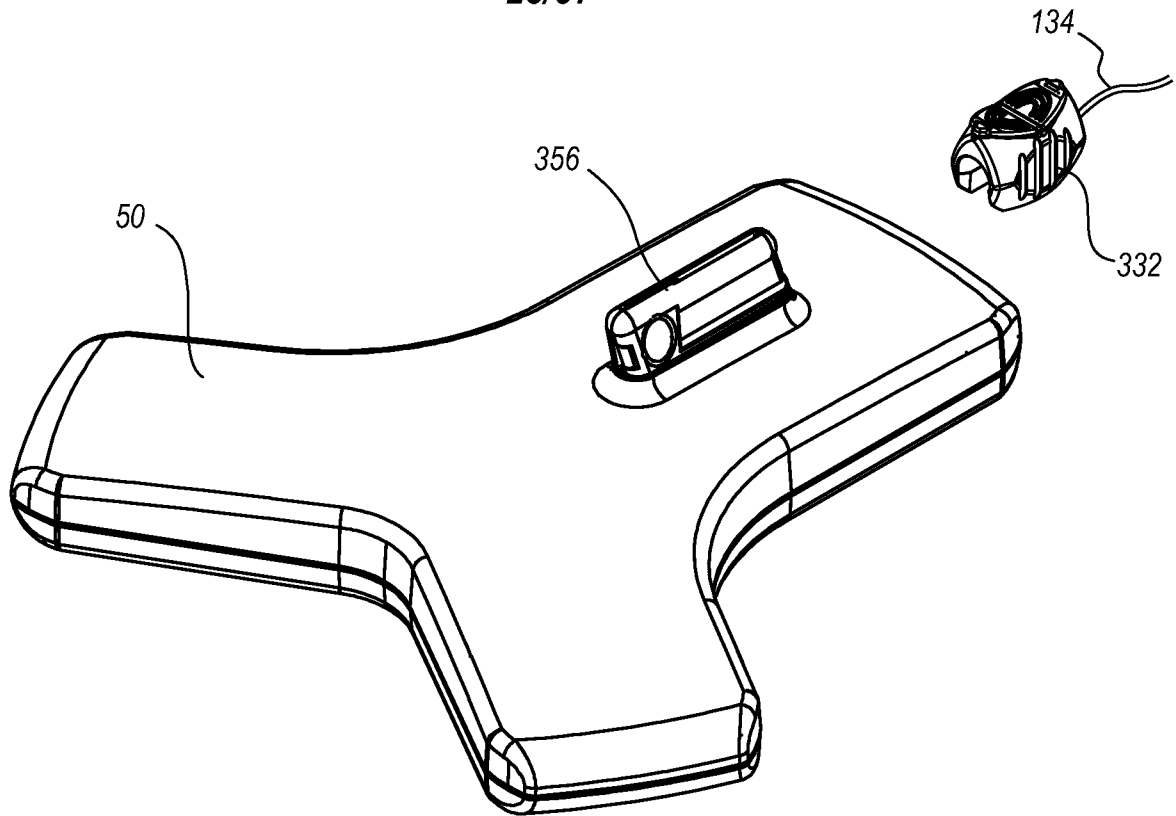

FIG. 22A

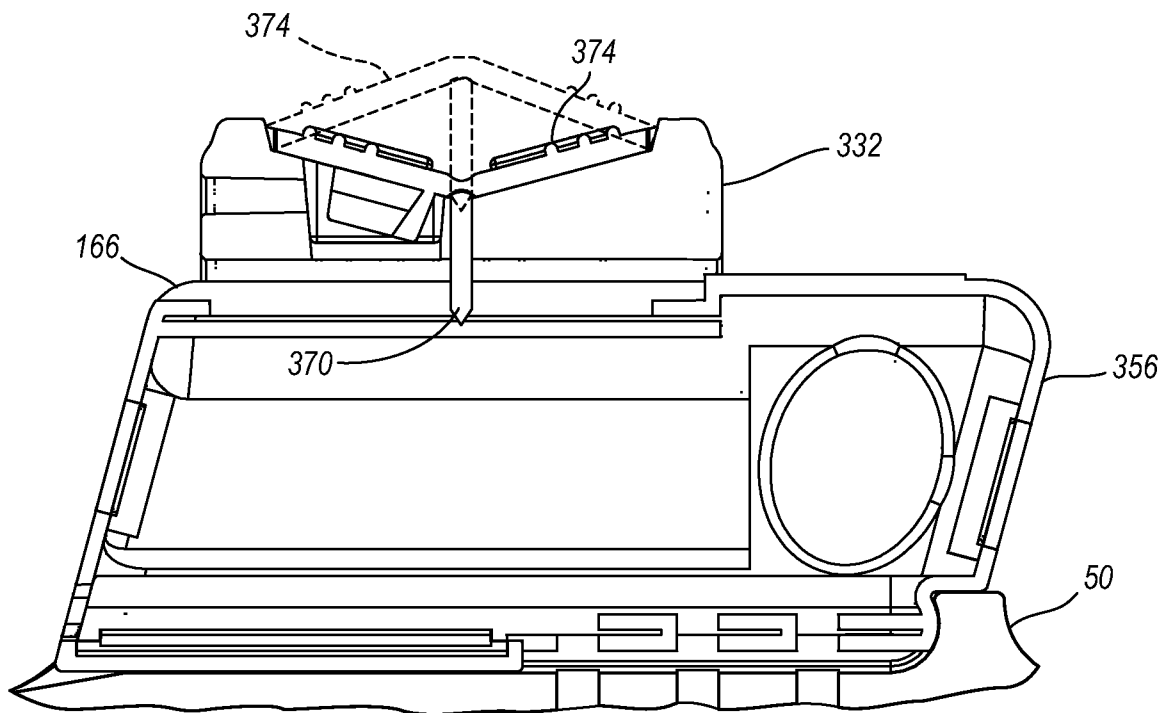

FIG. 22B

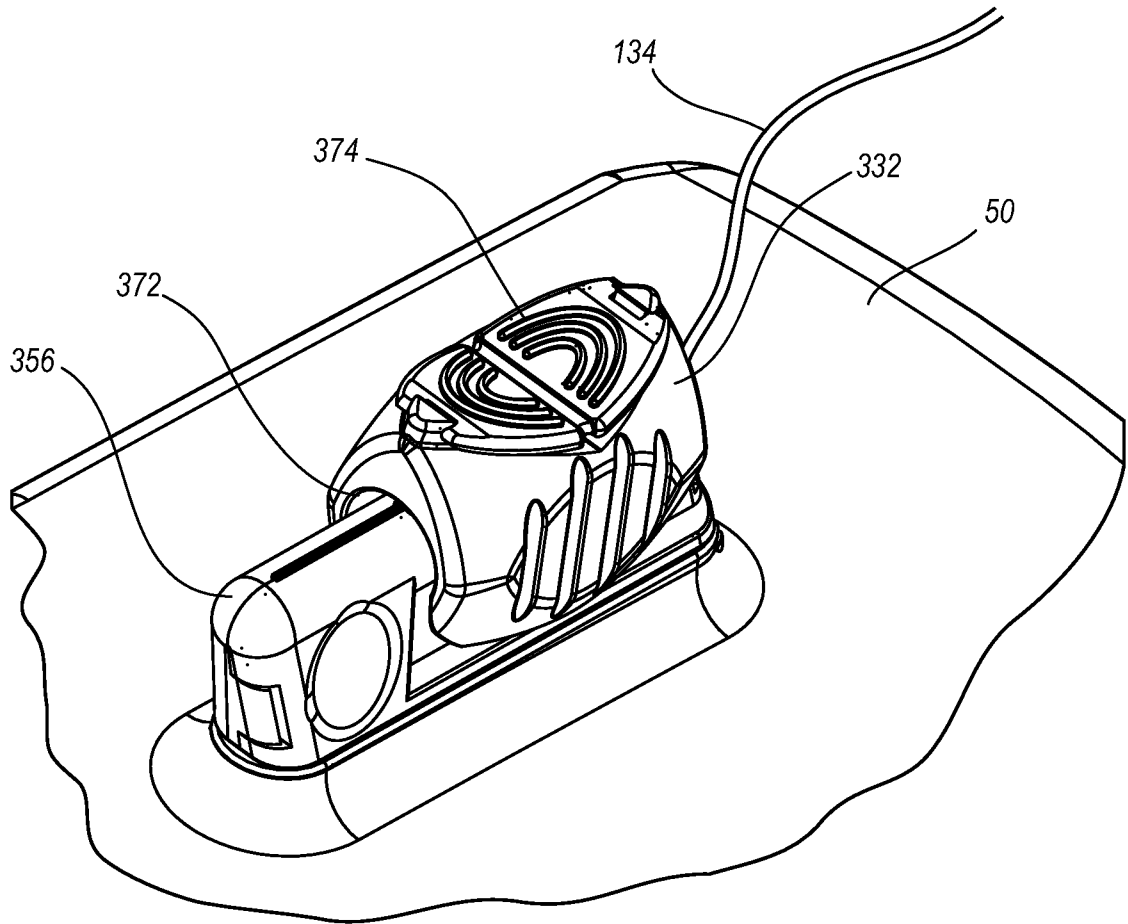

FIG. 22C

25/57

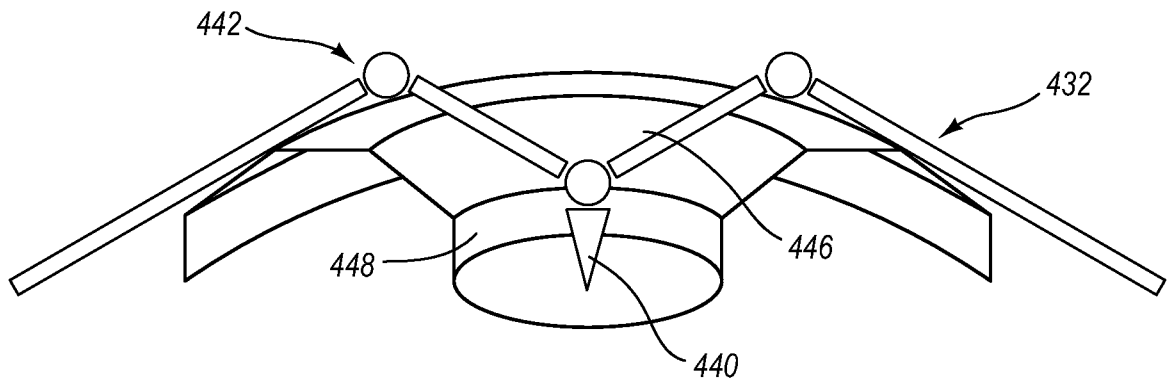

FIG. 23A

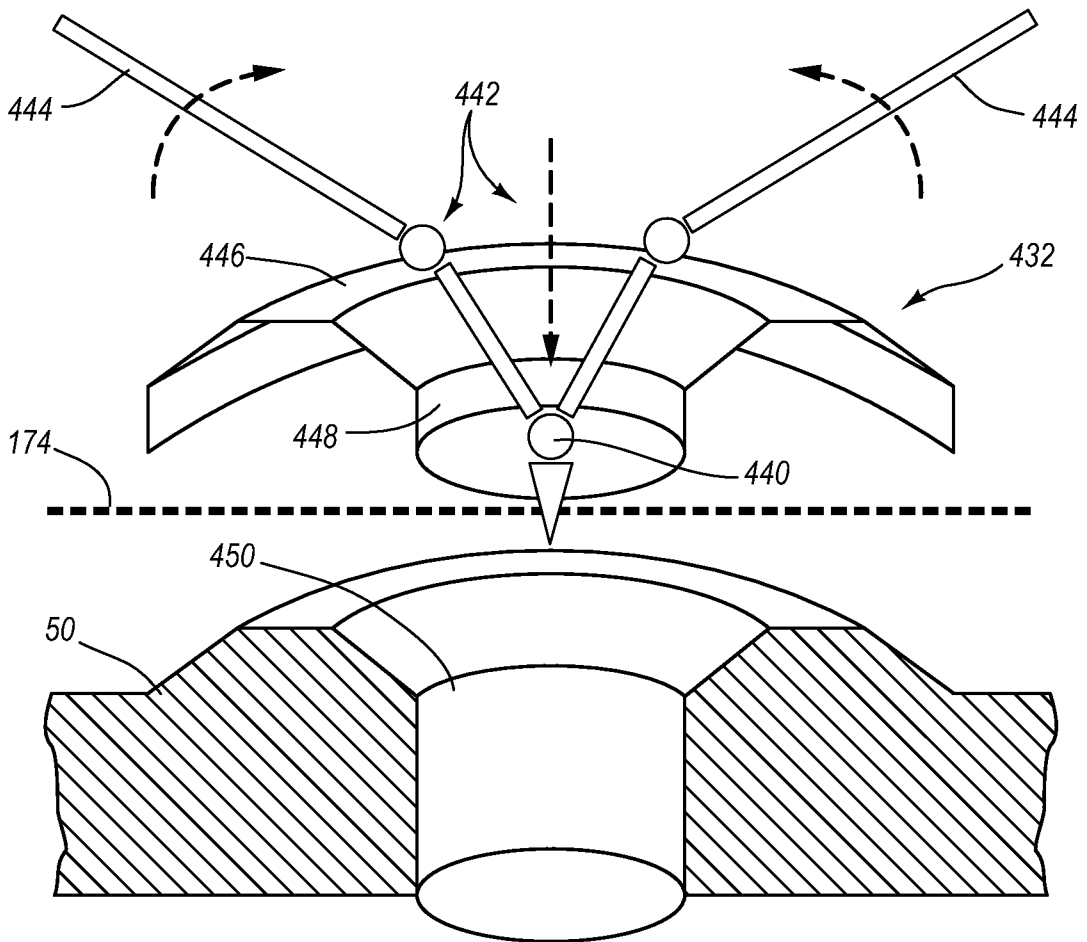

FIG. 23B

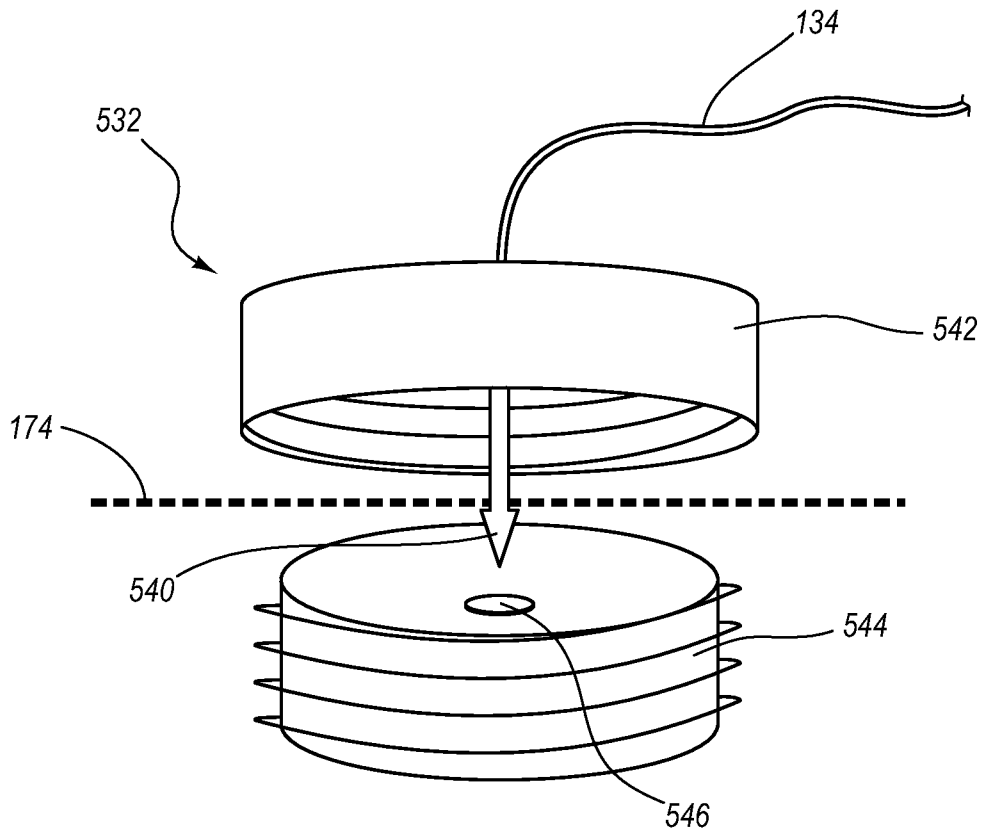

FIG. 24

27/57

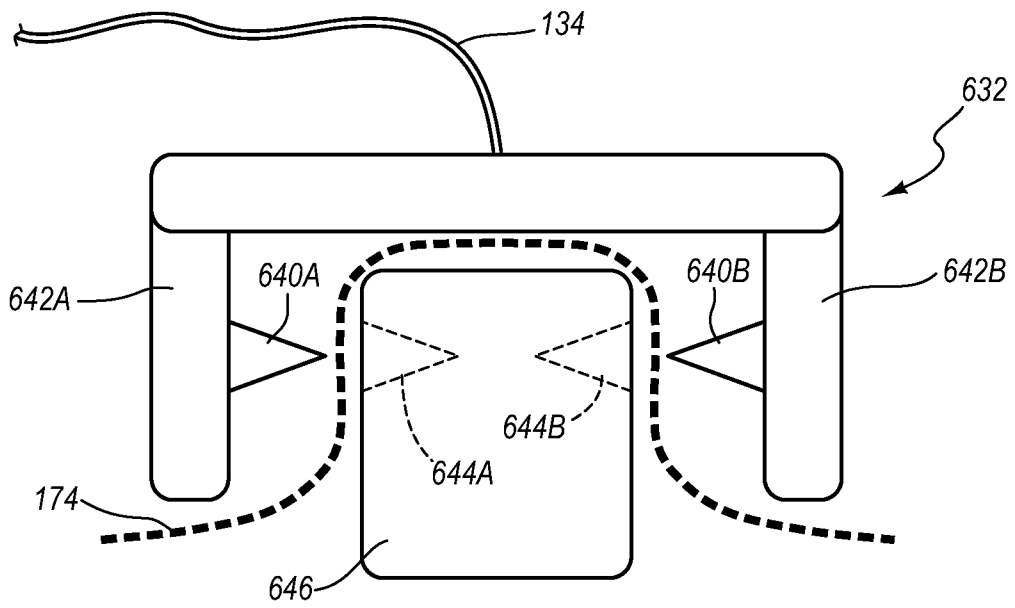

FIG. 25A

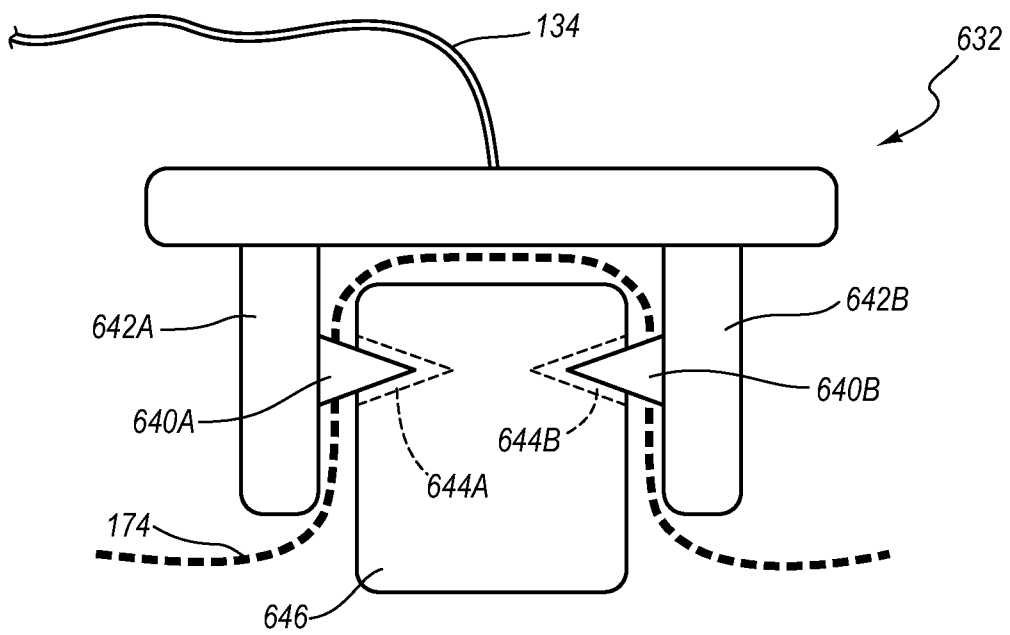

FIG. 25B

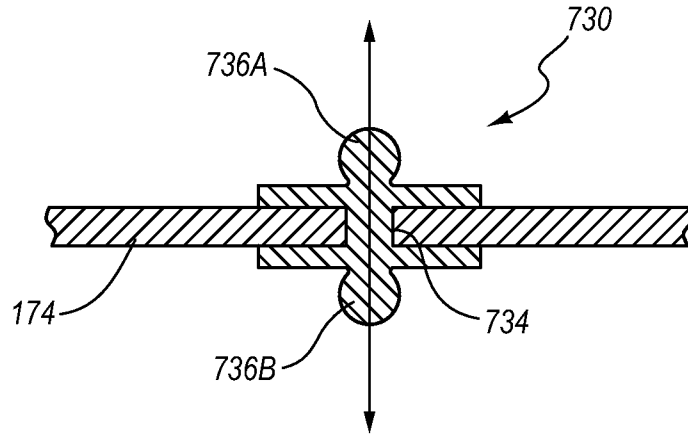

FIG. 26A

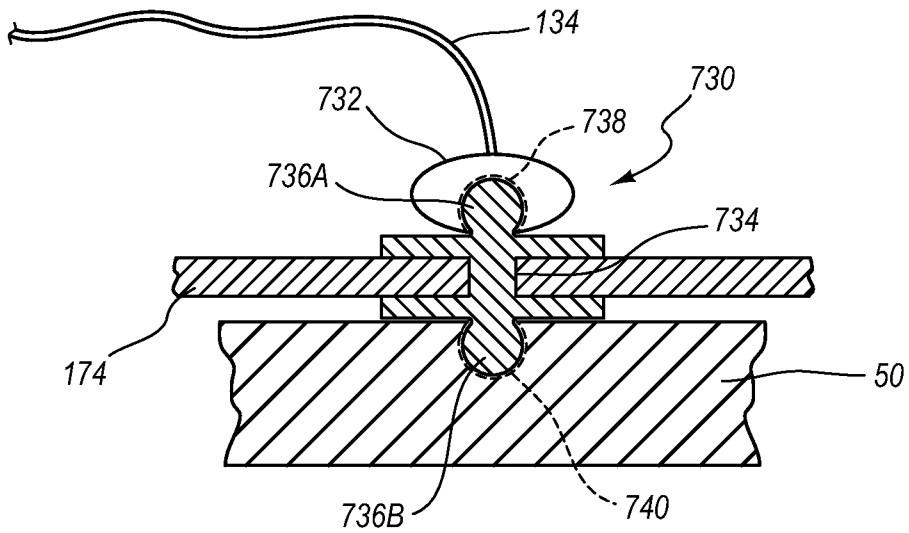

FIG. 26B

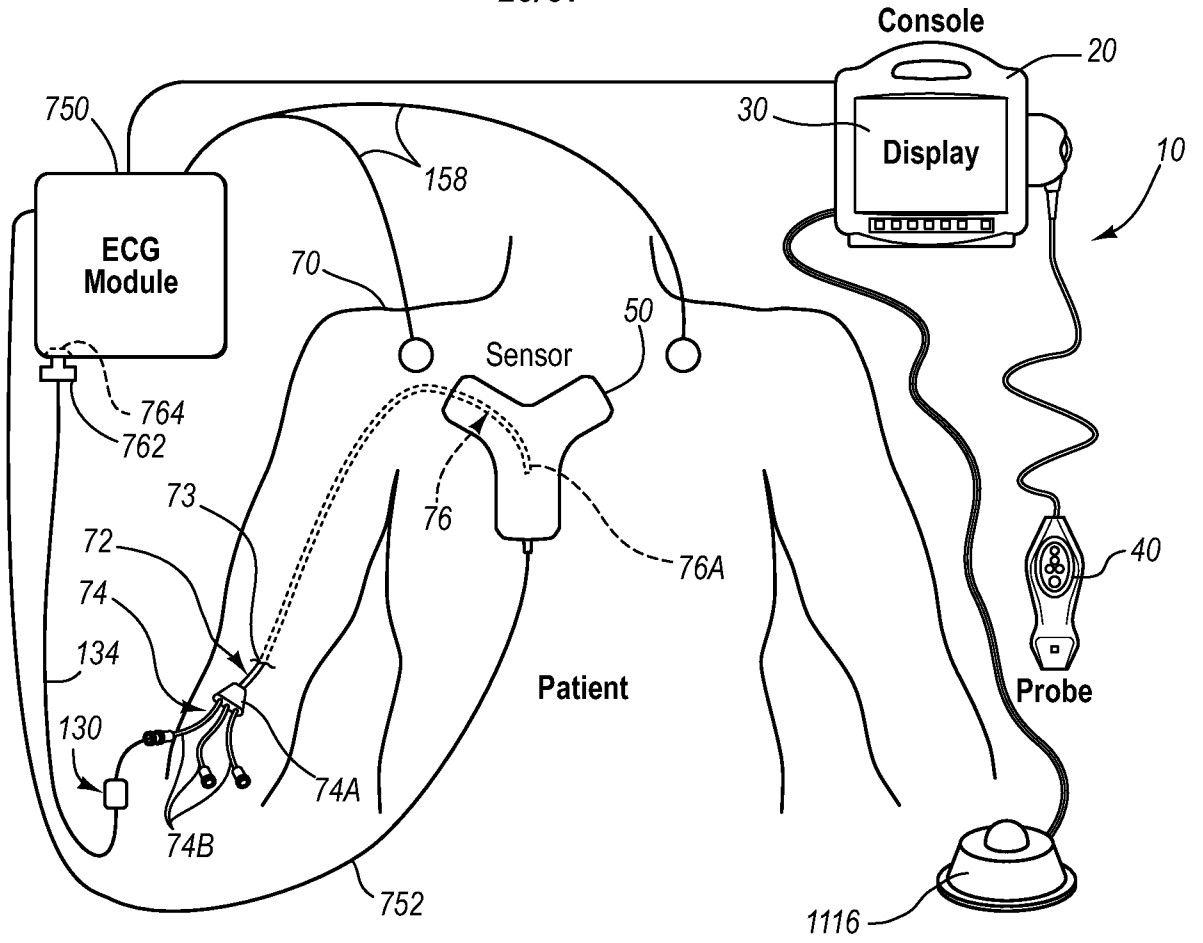

FIG. 27

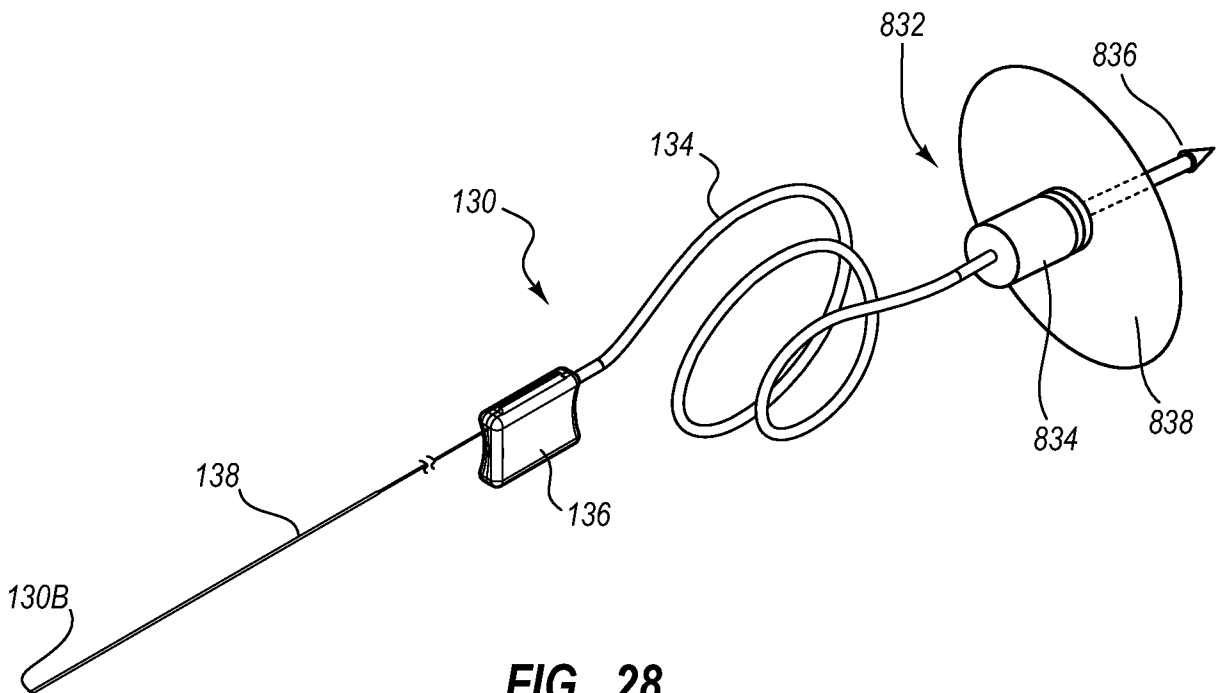
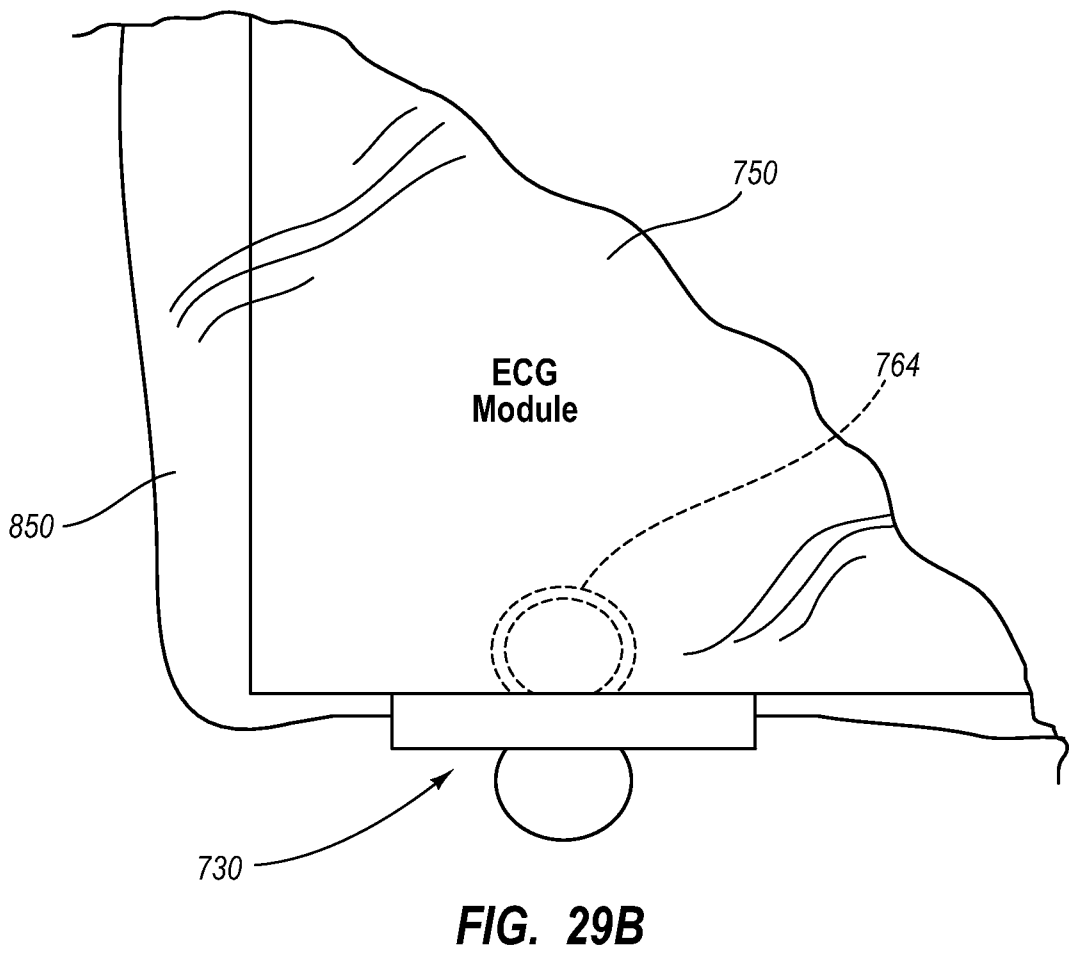
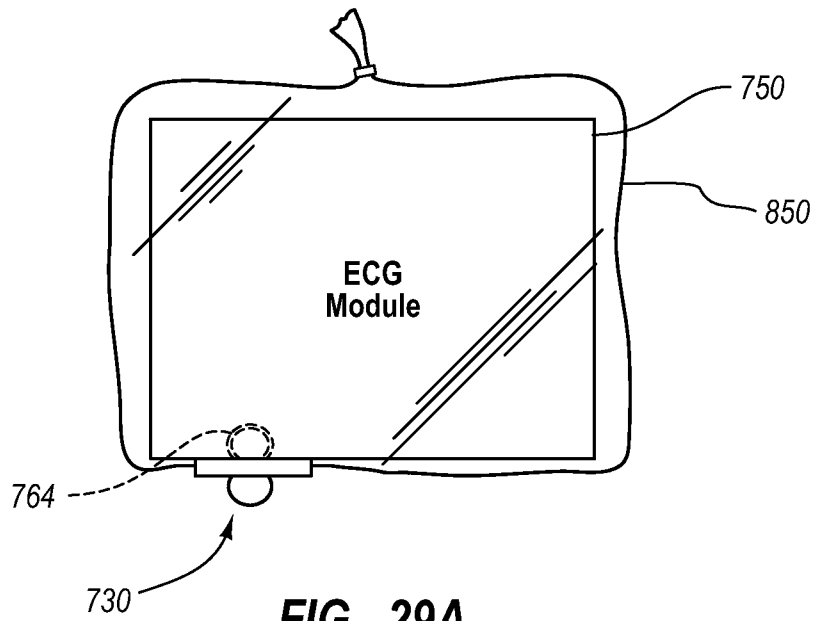

FIG. 28

30/57



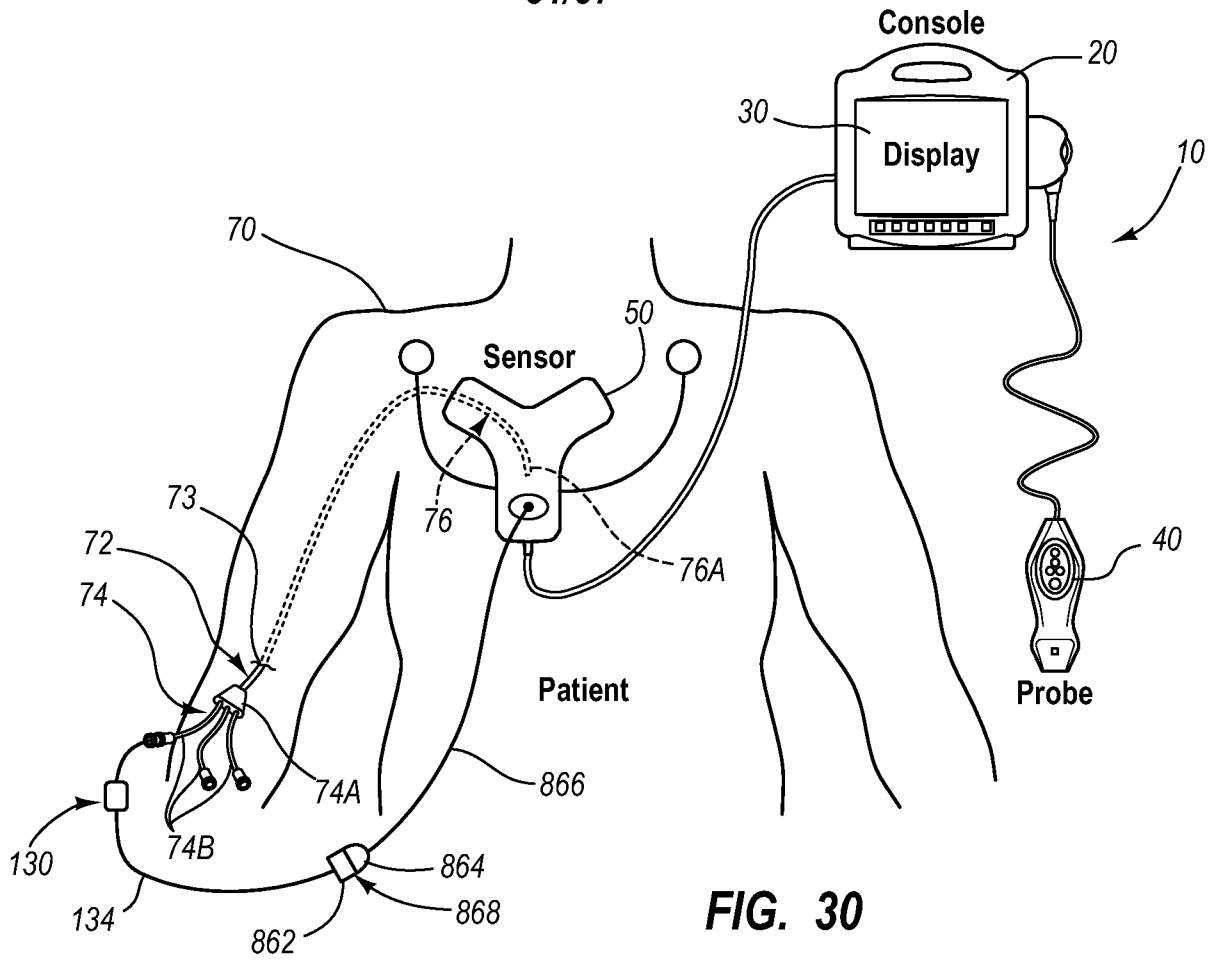

FIG. 30

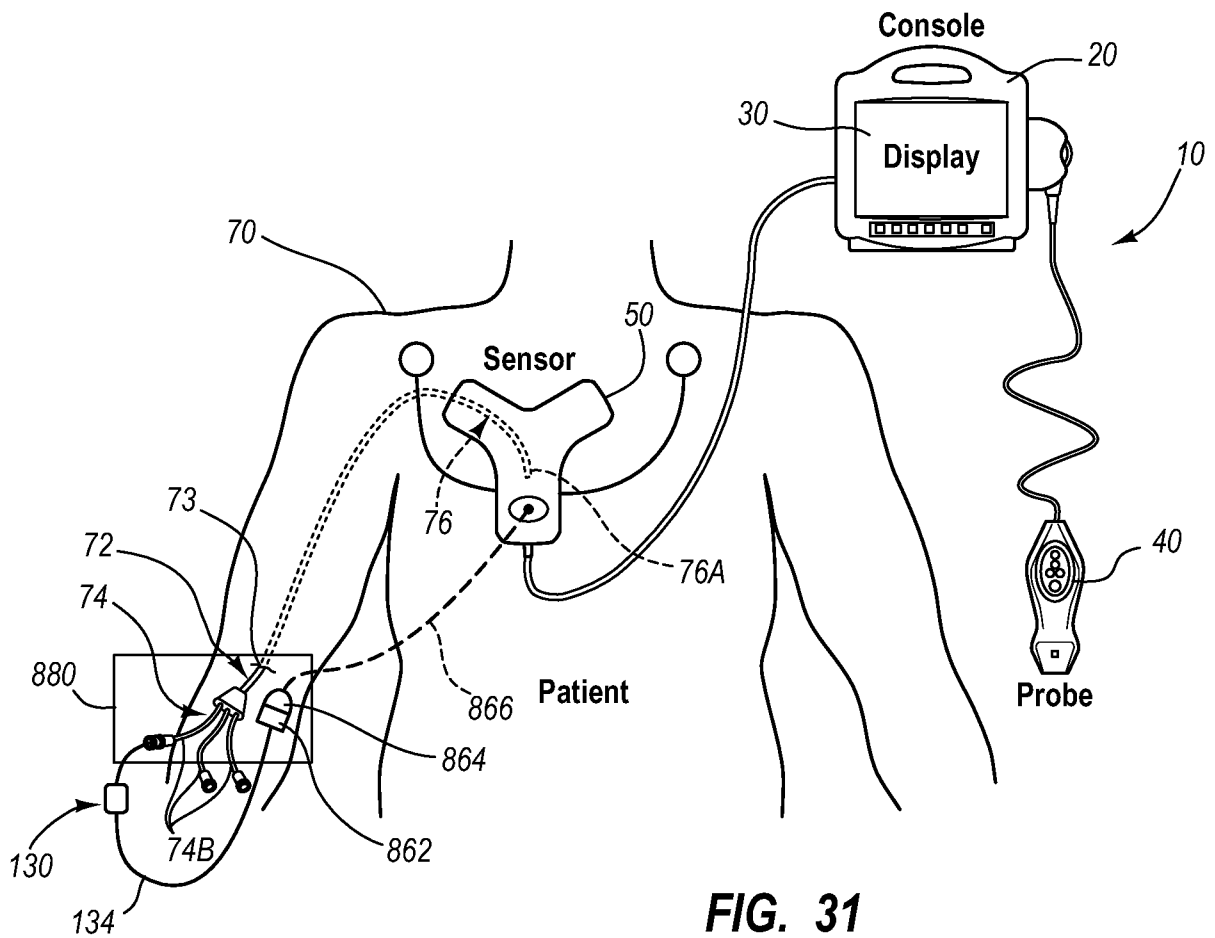

FIG. 31

32/57

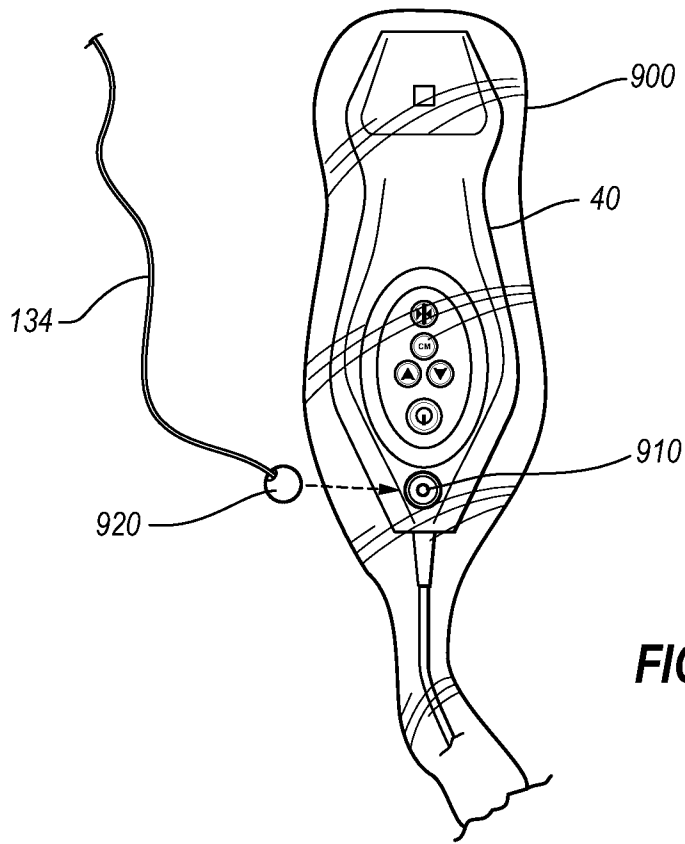

FIG. 32

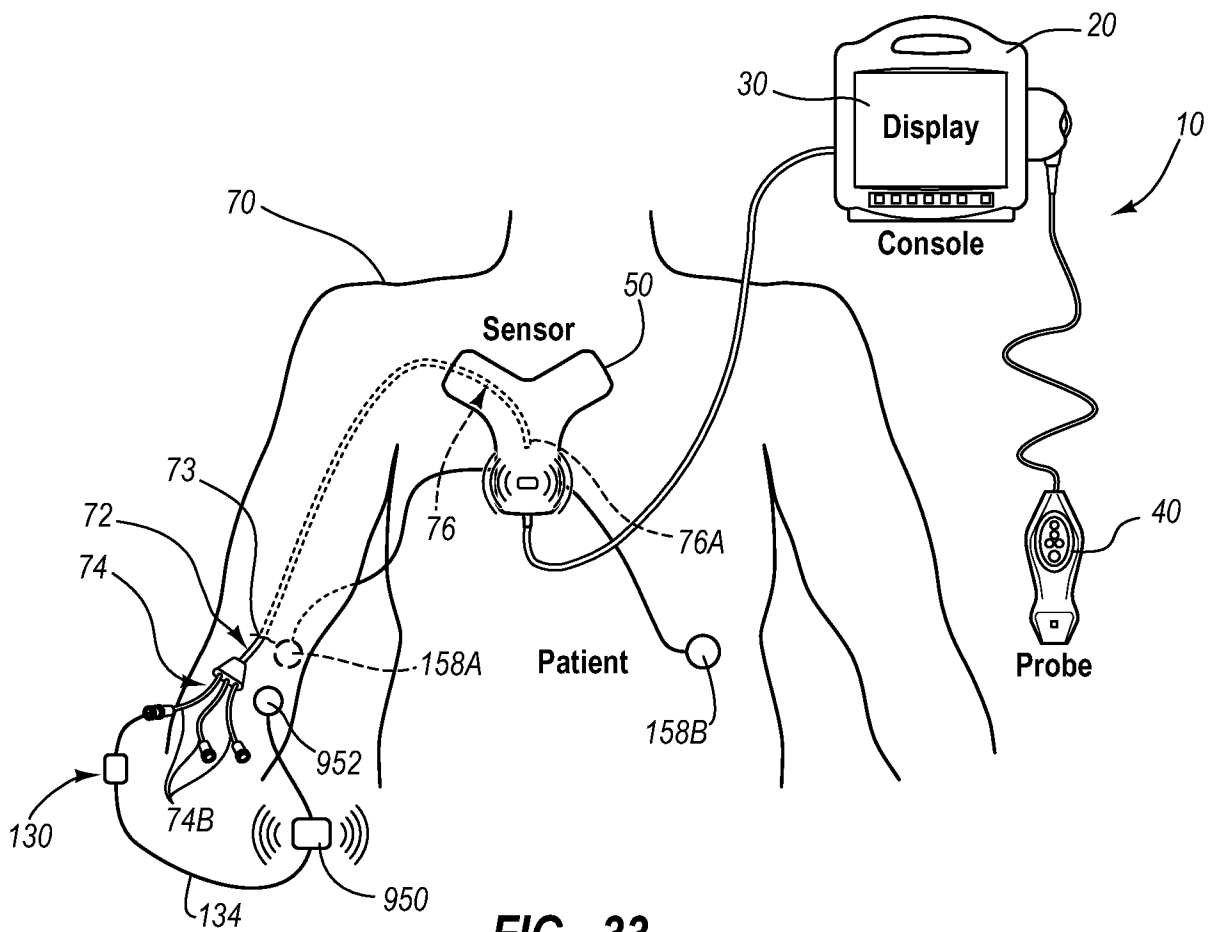

FIG. 33

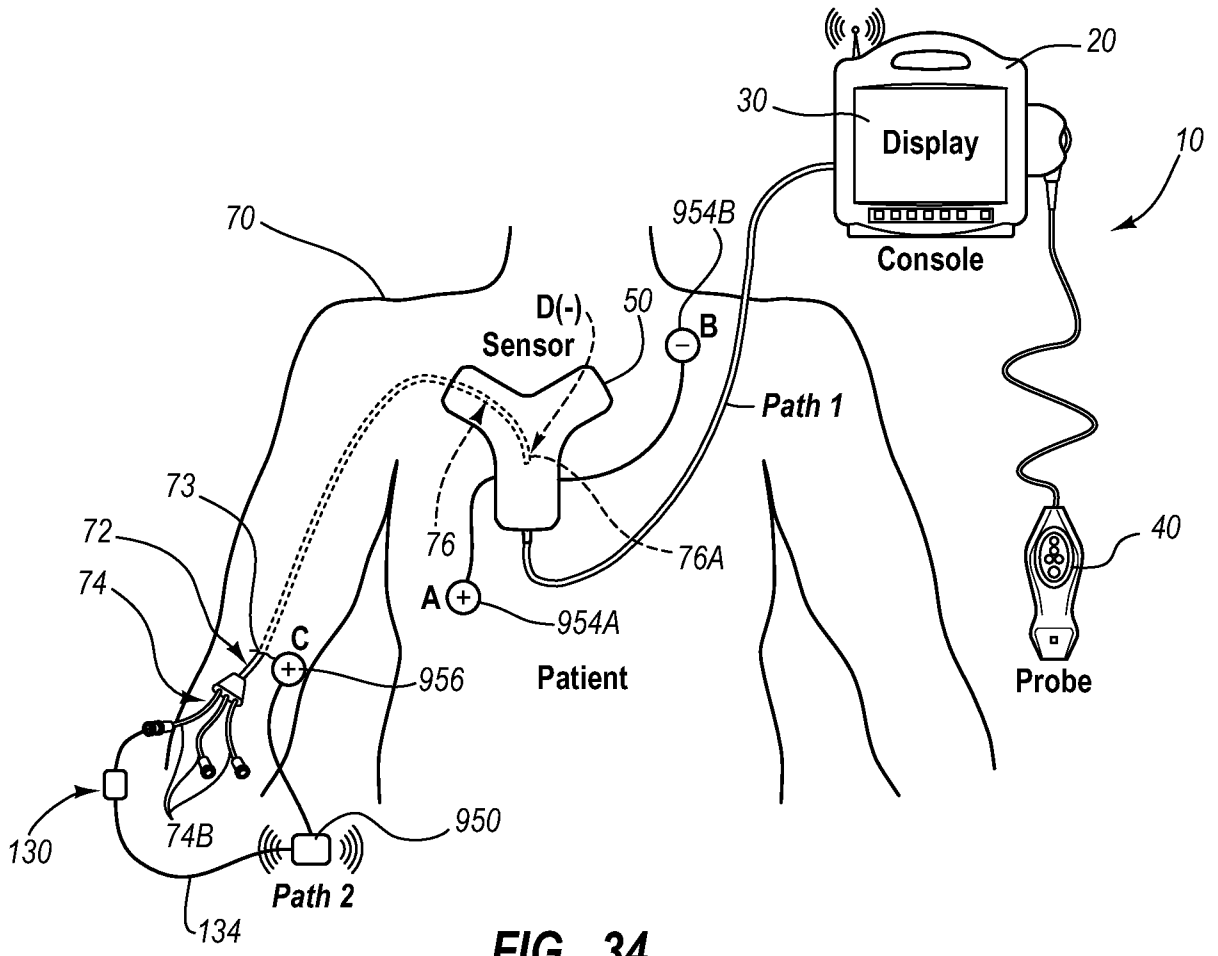

FIG. 34

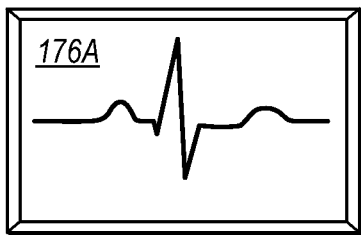

FIG. 35A

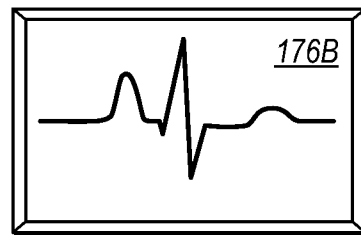

FIG. 35B

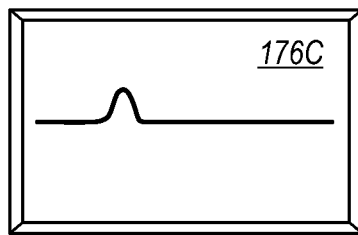

FIG. 35C

34/57

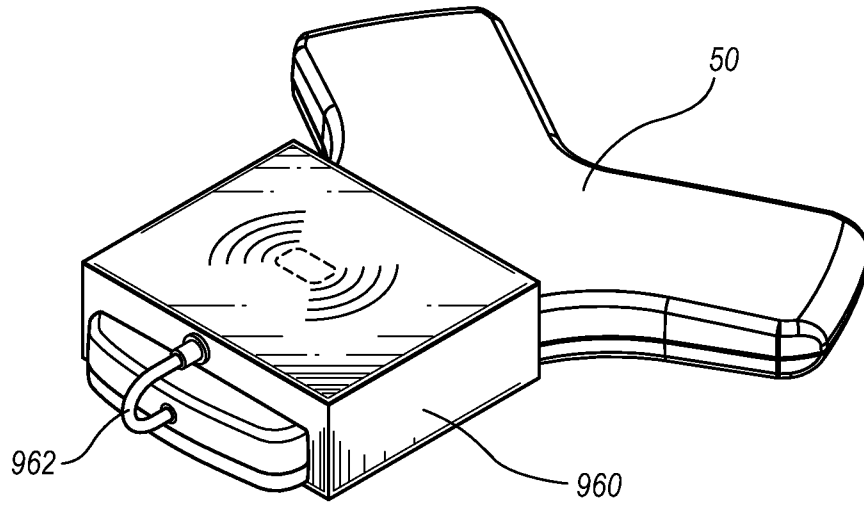

FIG. 36

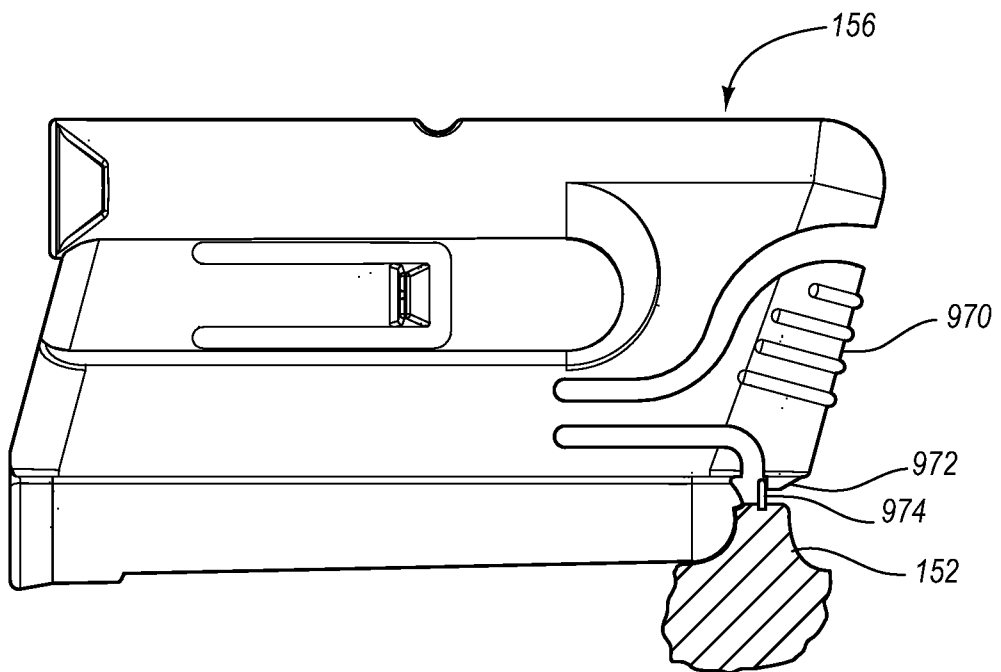

FIG. 37

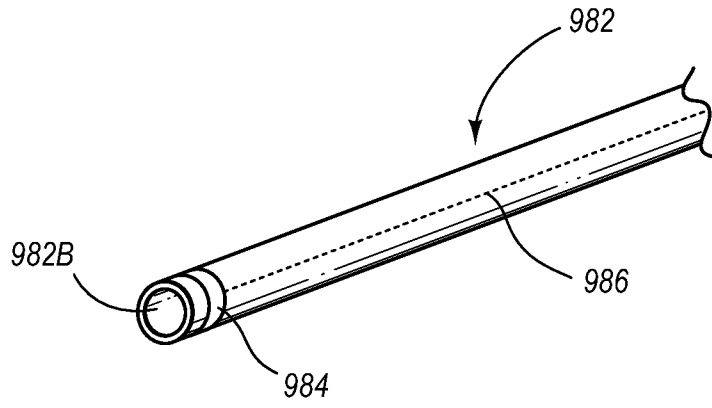

FIG. 38

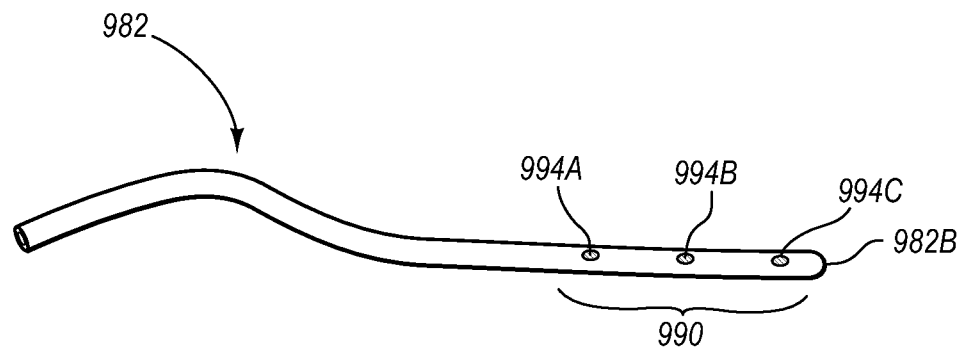

FIG. 39

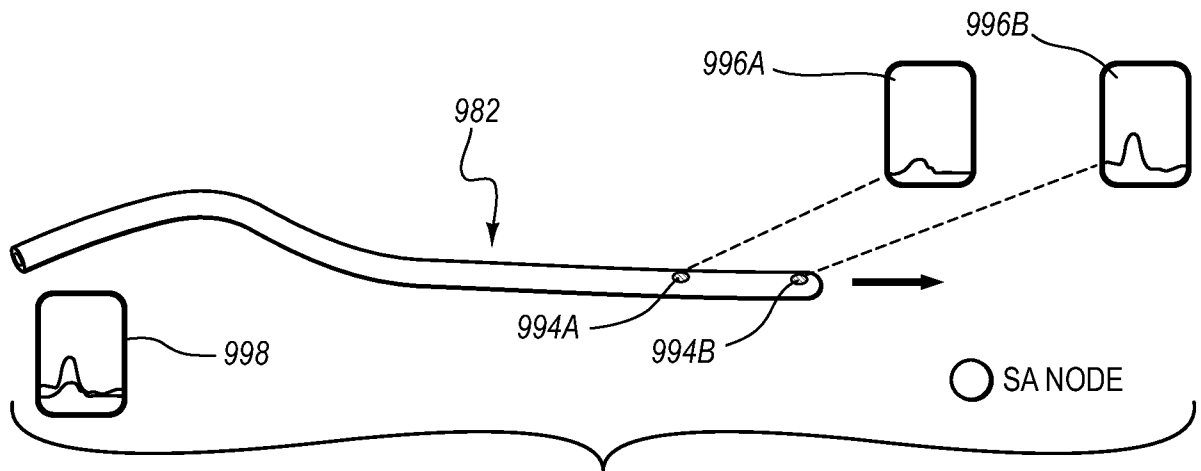

FIG. 40A

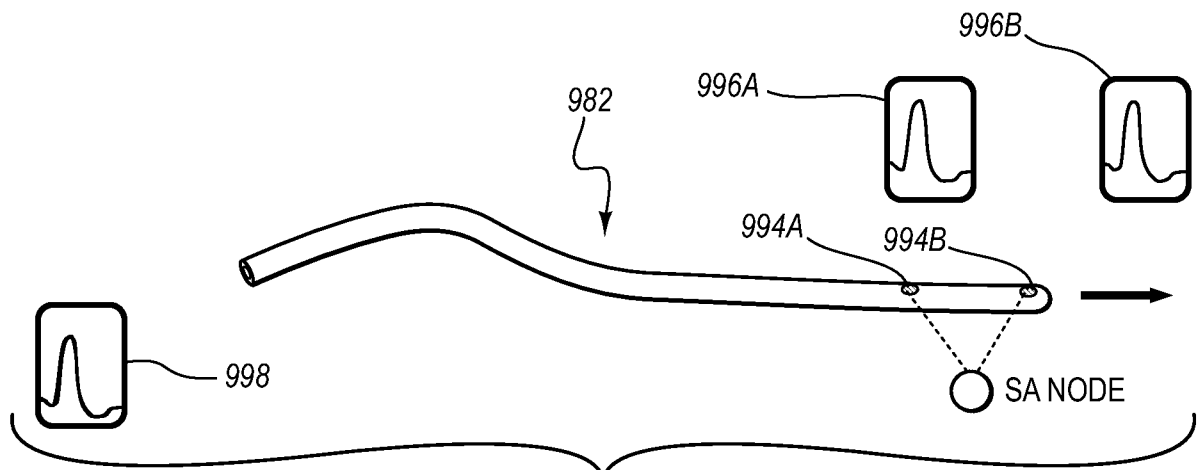

FIG. 40B

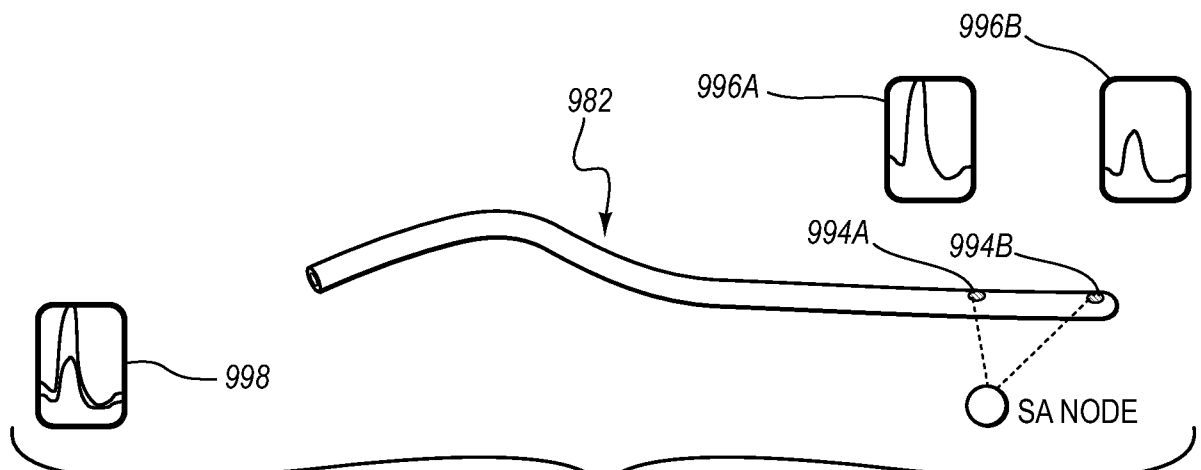

FIG. 40C

37/57

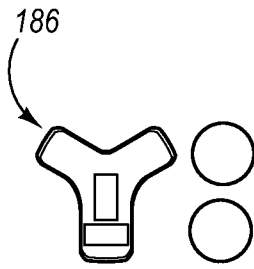

FIG. 41A

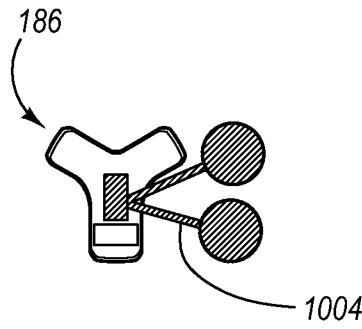

FIG. 41B

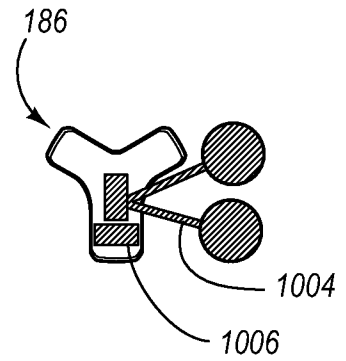

FIG. 41C

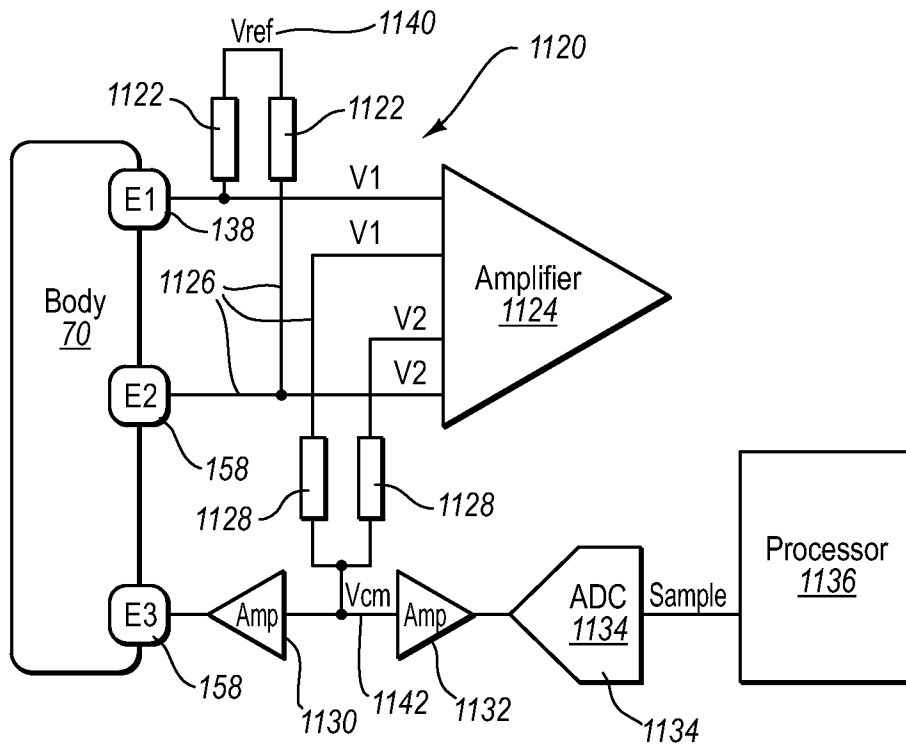

FIG. 41D

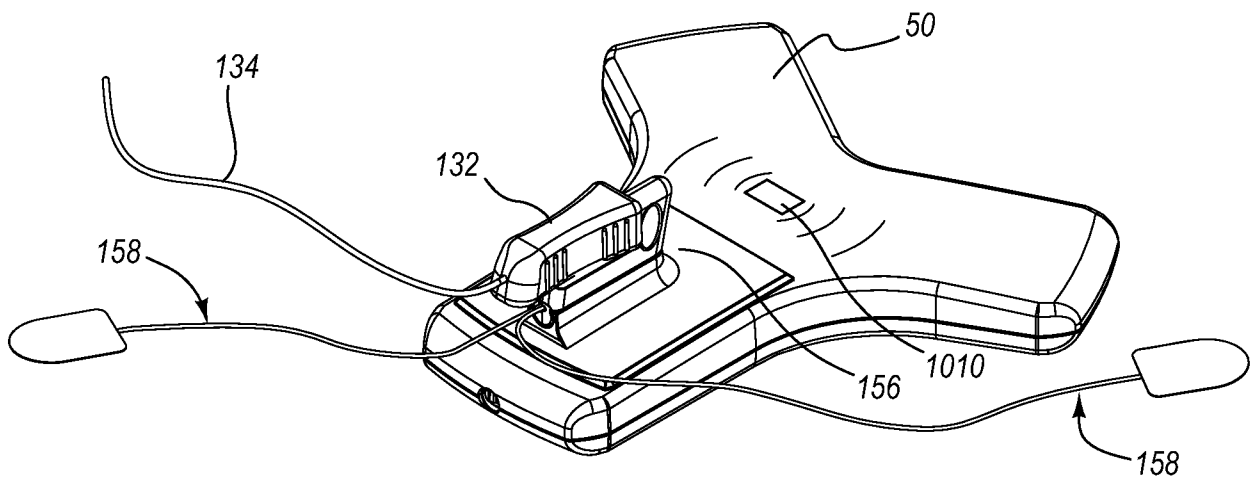

FIG. 42

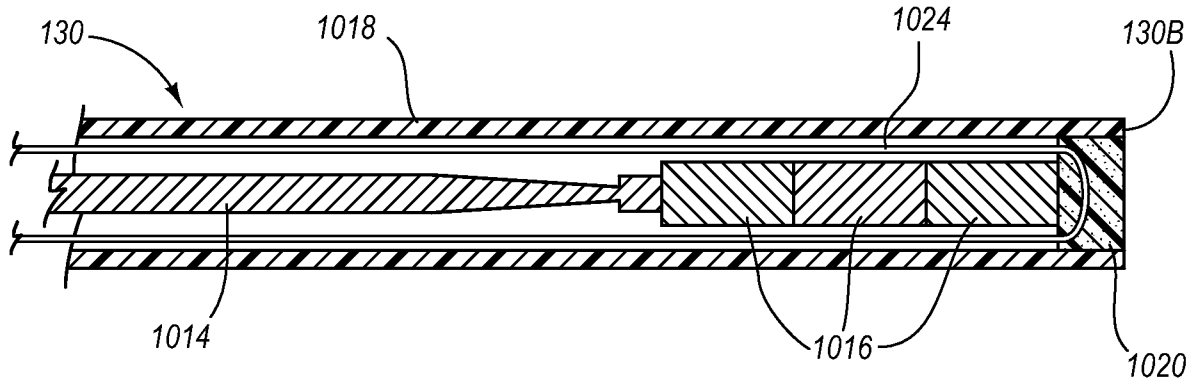

FIG. 43A

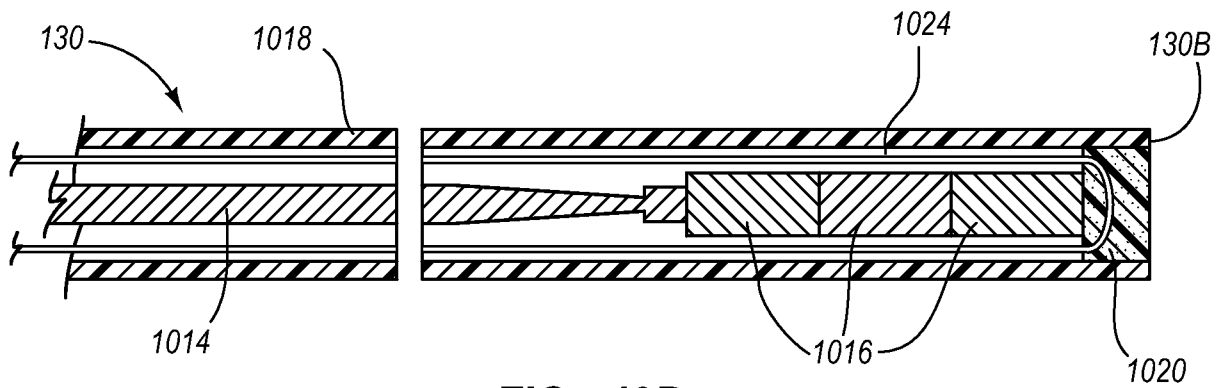

FIG. 43B

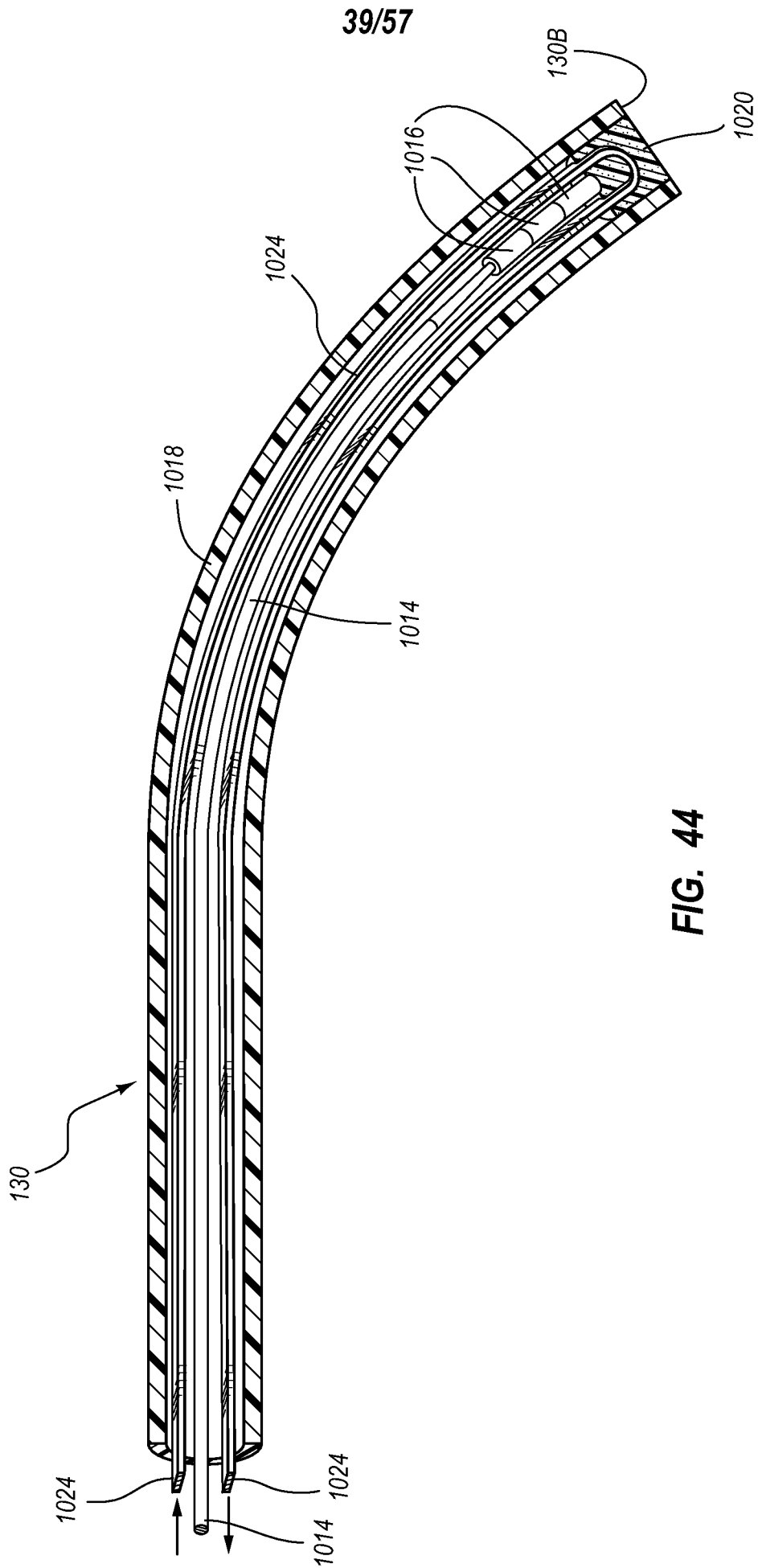

FIG. 44

40/57

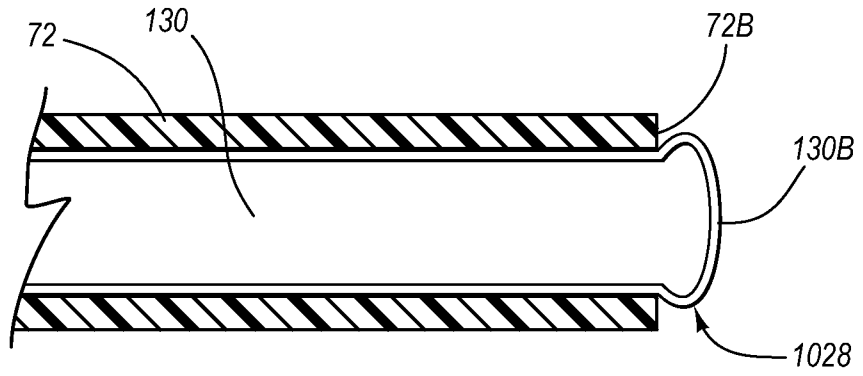

FIG. 45



FIG. 46

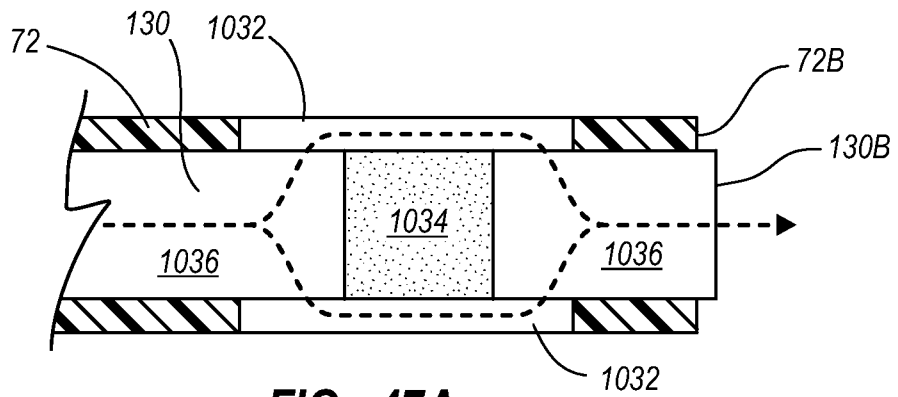

FIG. 47A

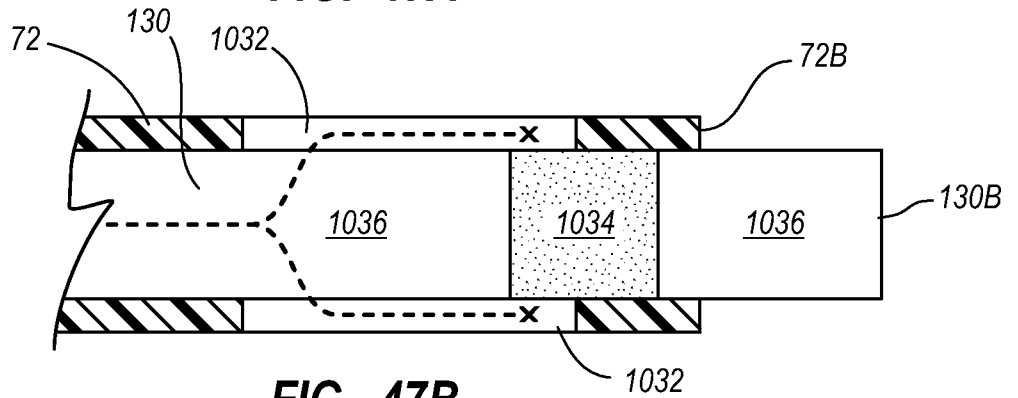

FIG. 47B

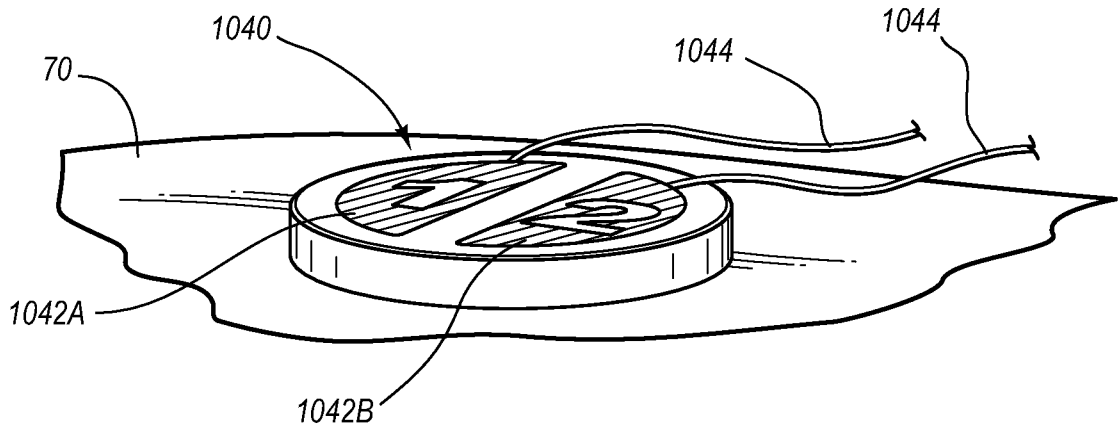

FIG. 48

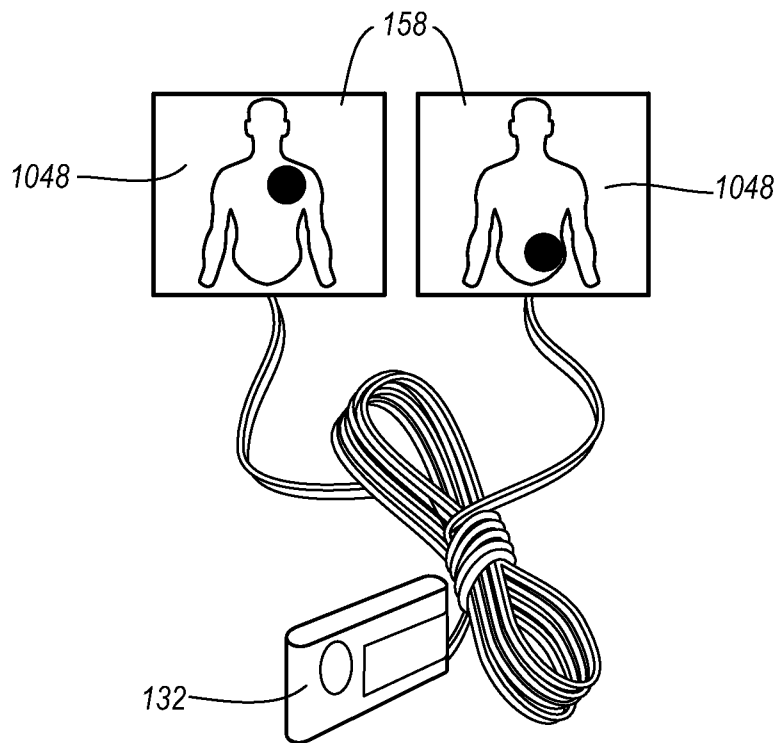

FIG. 49

42/57

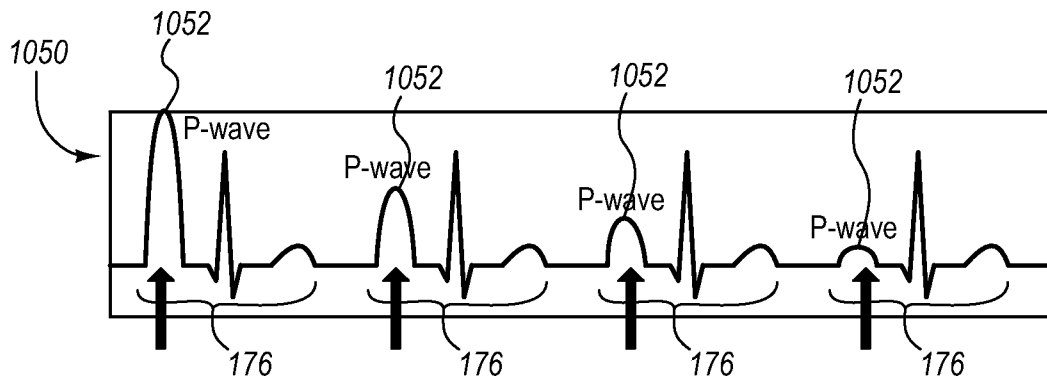

FIG. 50

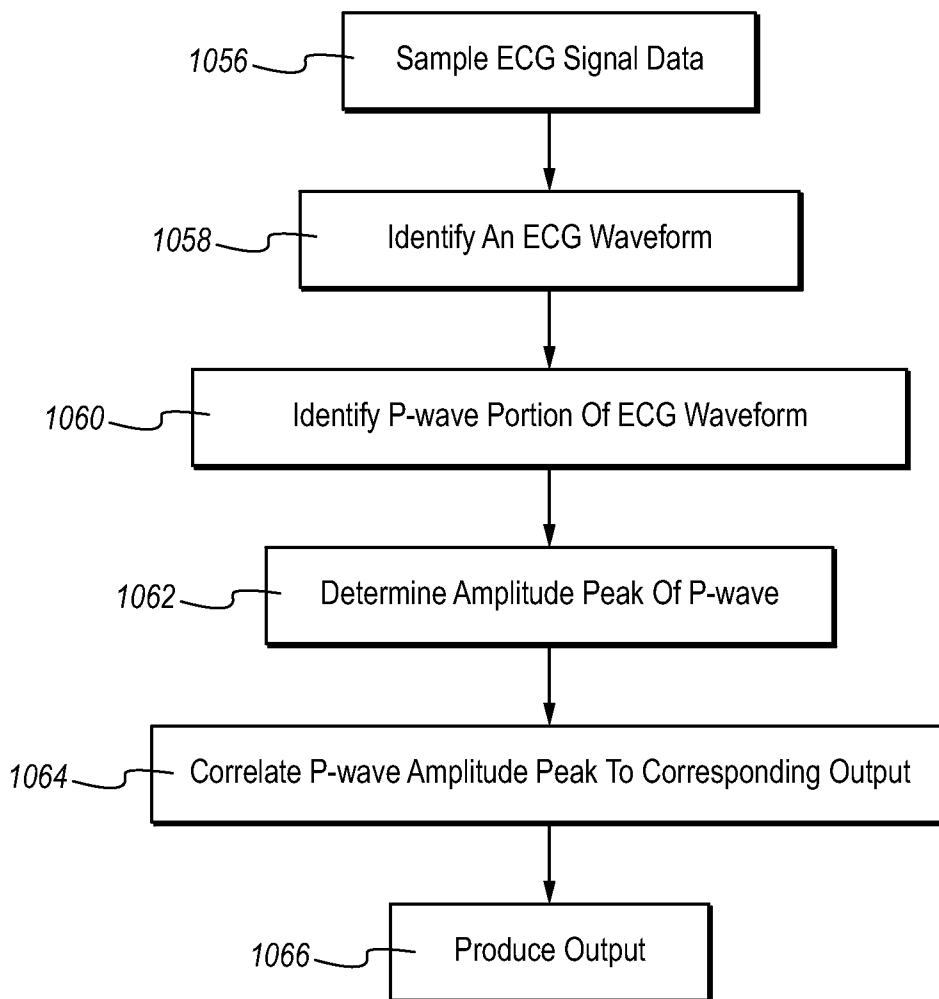

FIG. 51

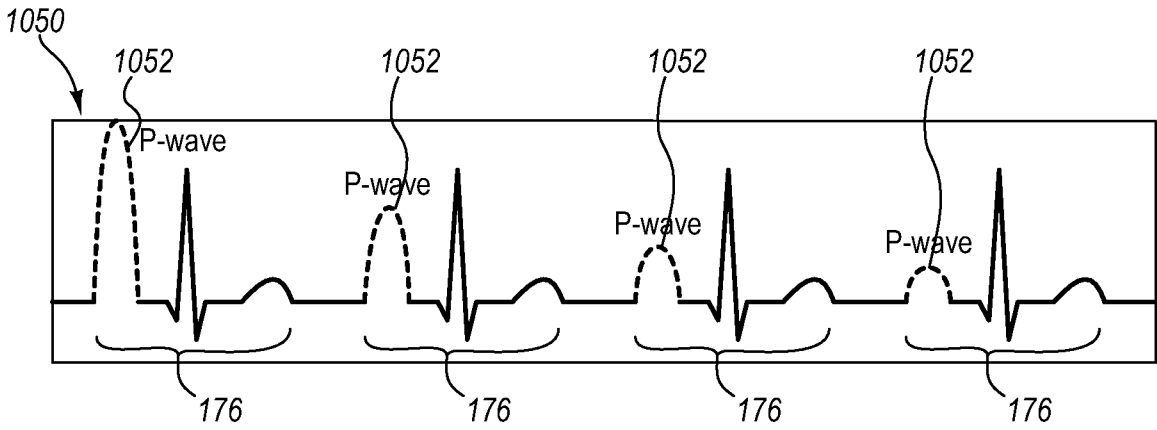

FIG. 52

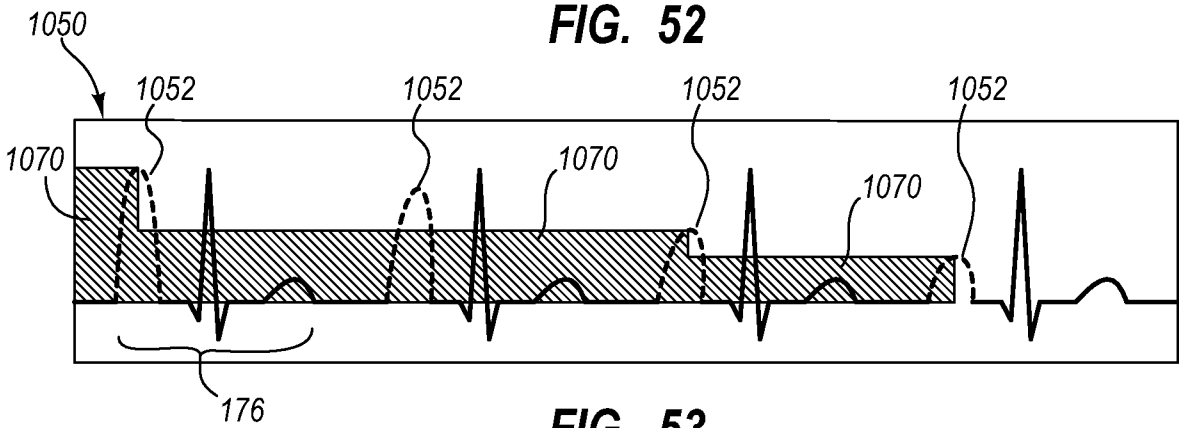

FIG. 53

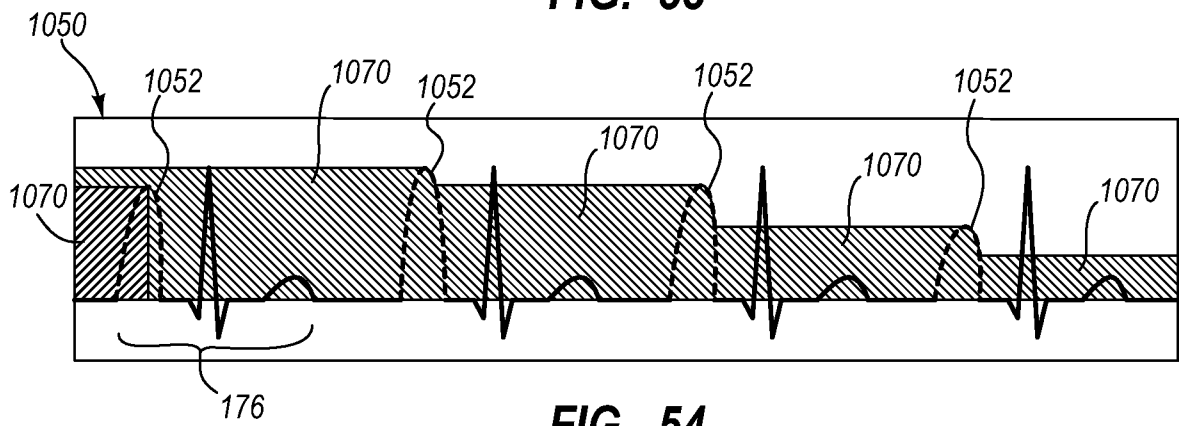

FIG. 54

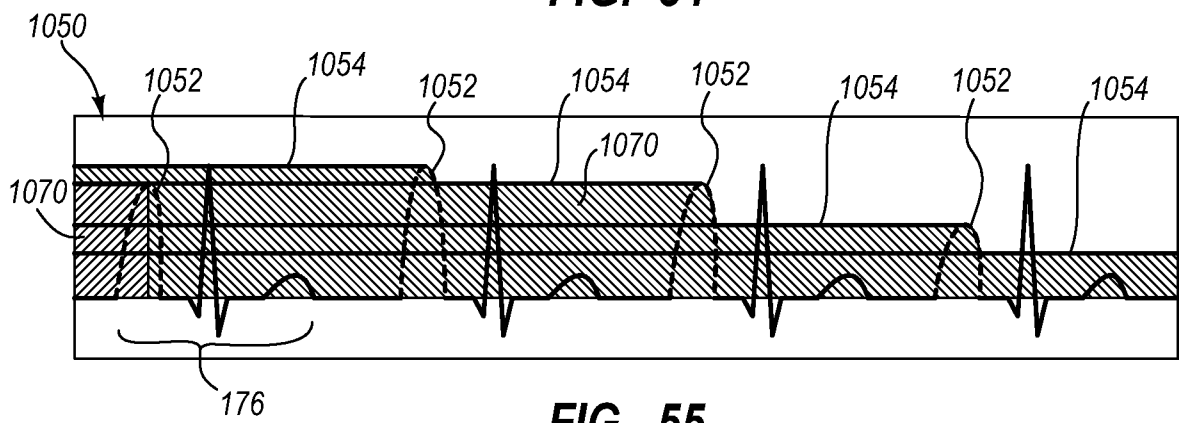

FIG. 55

44/57

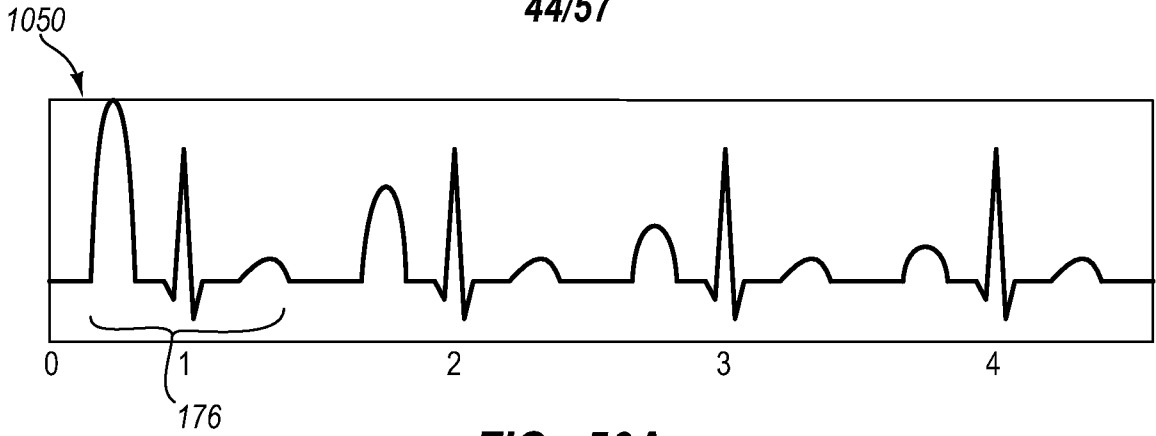

FIG. 56A

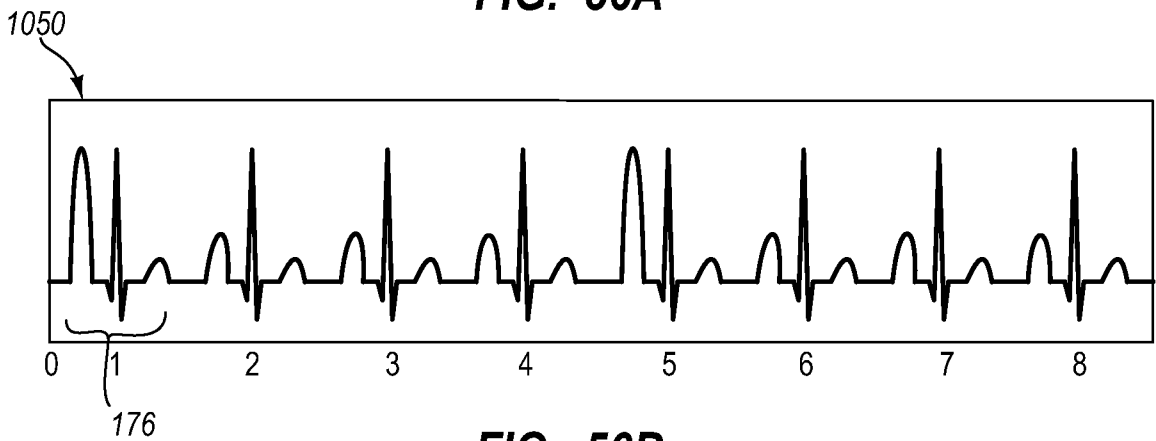

FIG. 56B



FIG. 57A

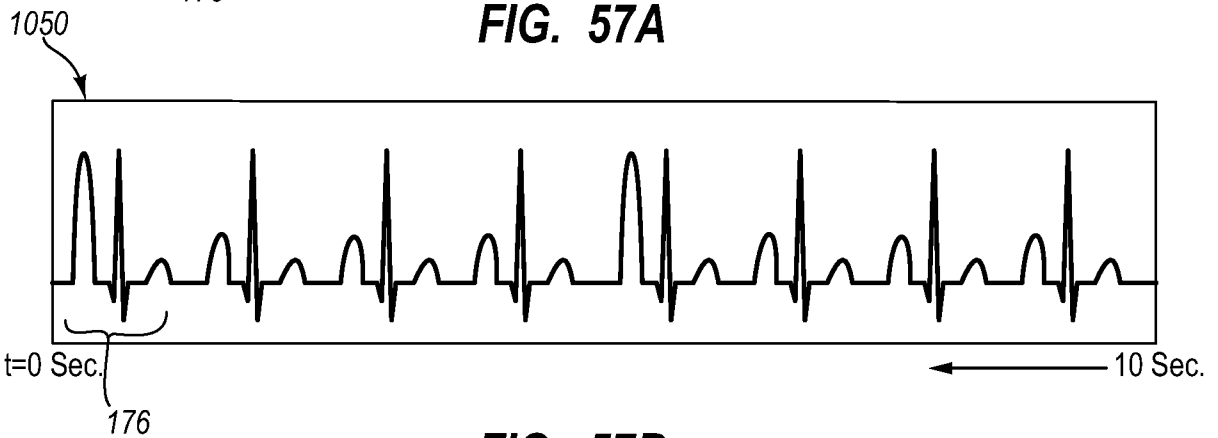

FIG. 57B

45/57

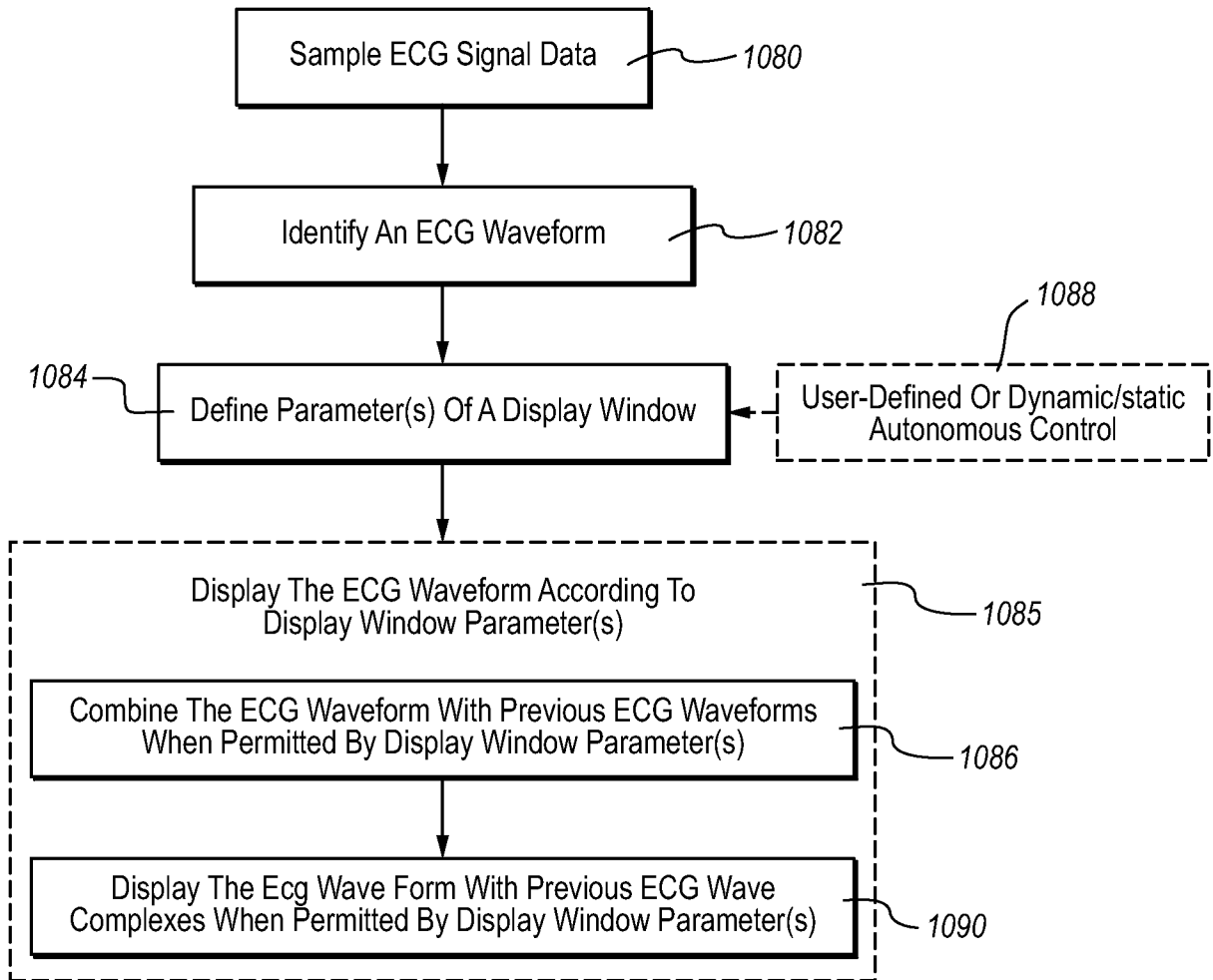

FIG. 58

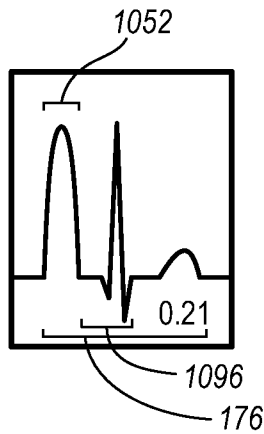

FIG. 59

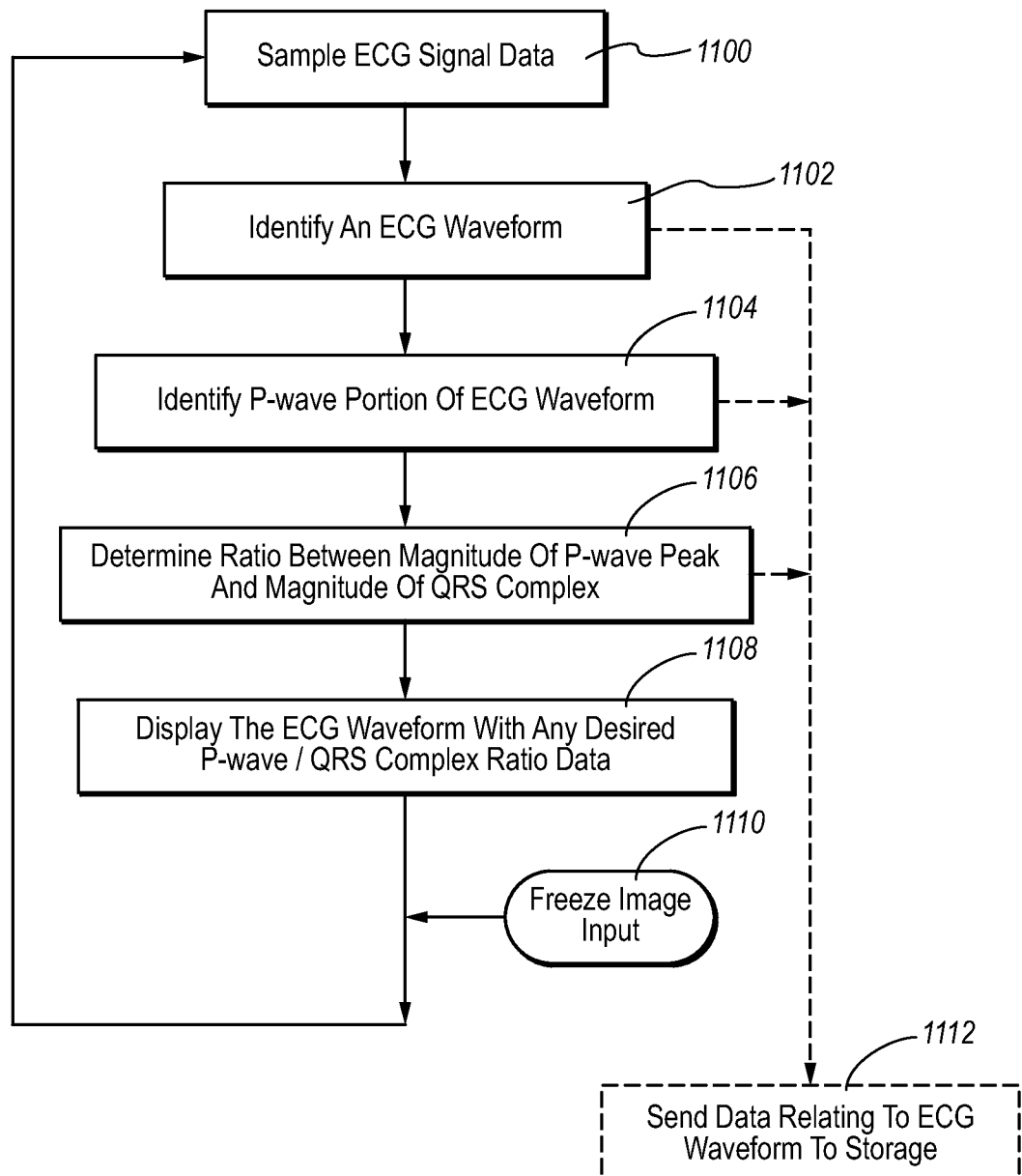

FIG. 60

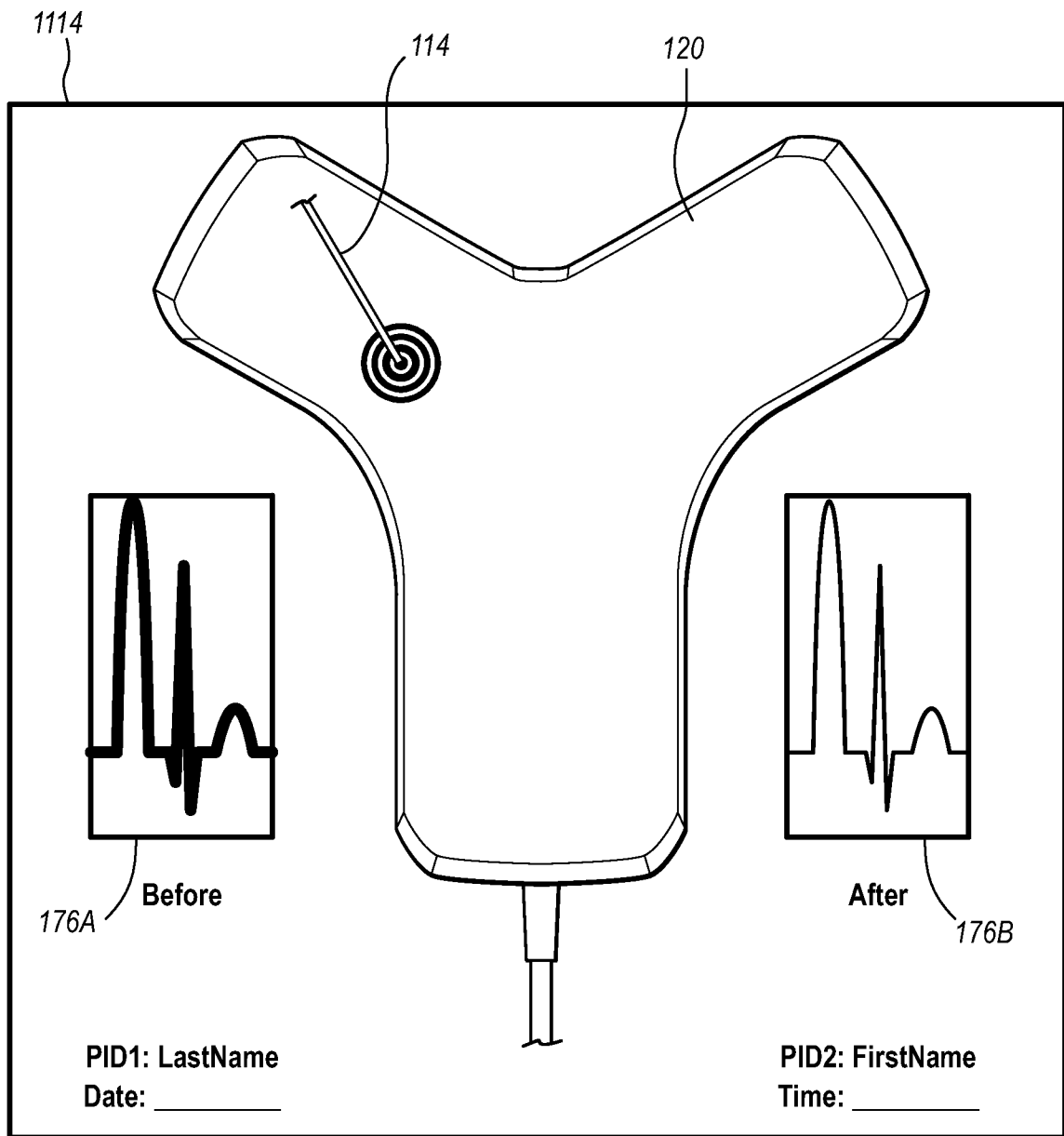

FIG. 61

48/57

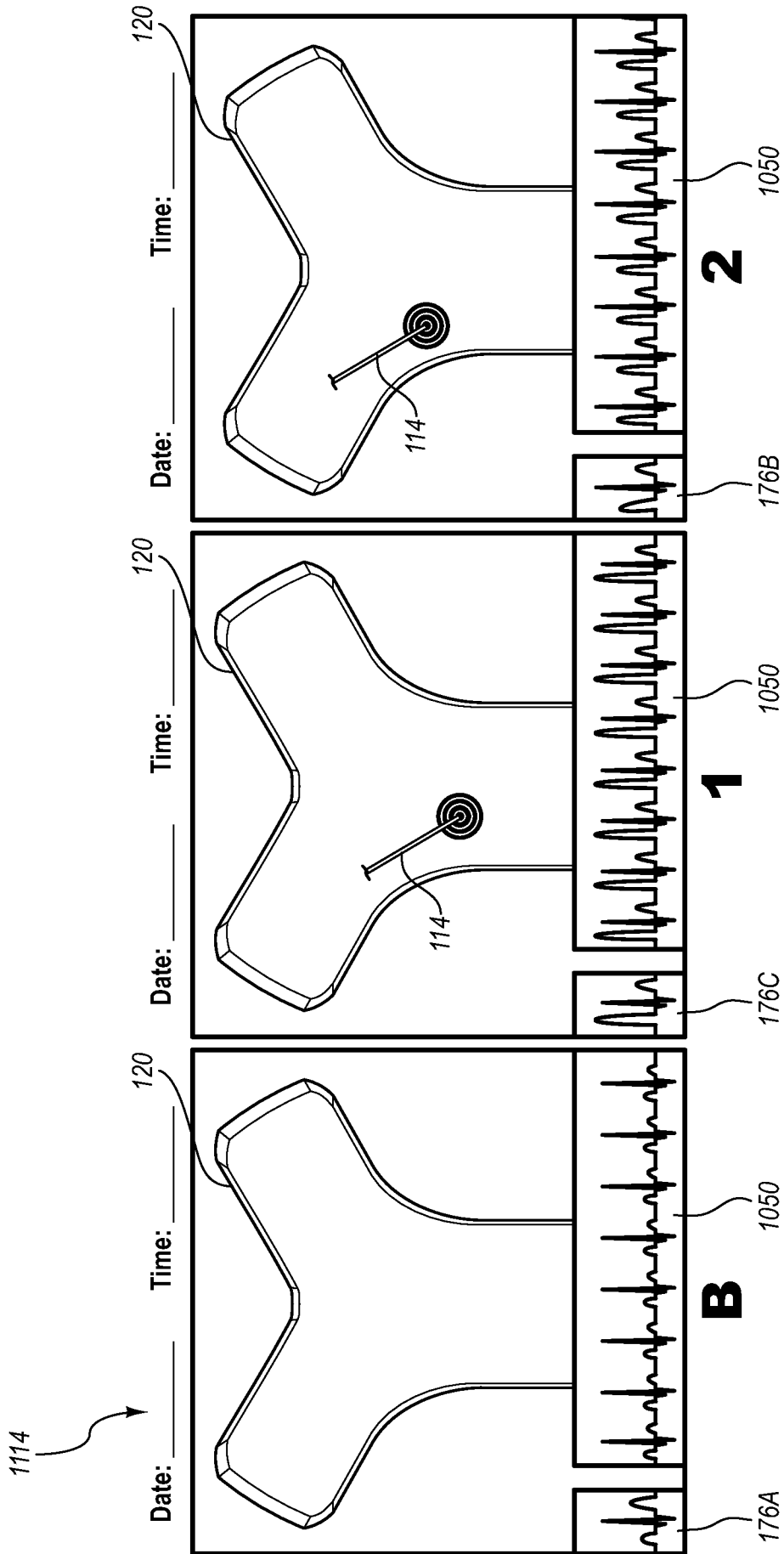

FIG. 62

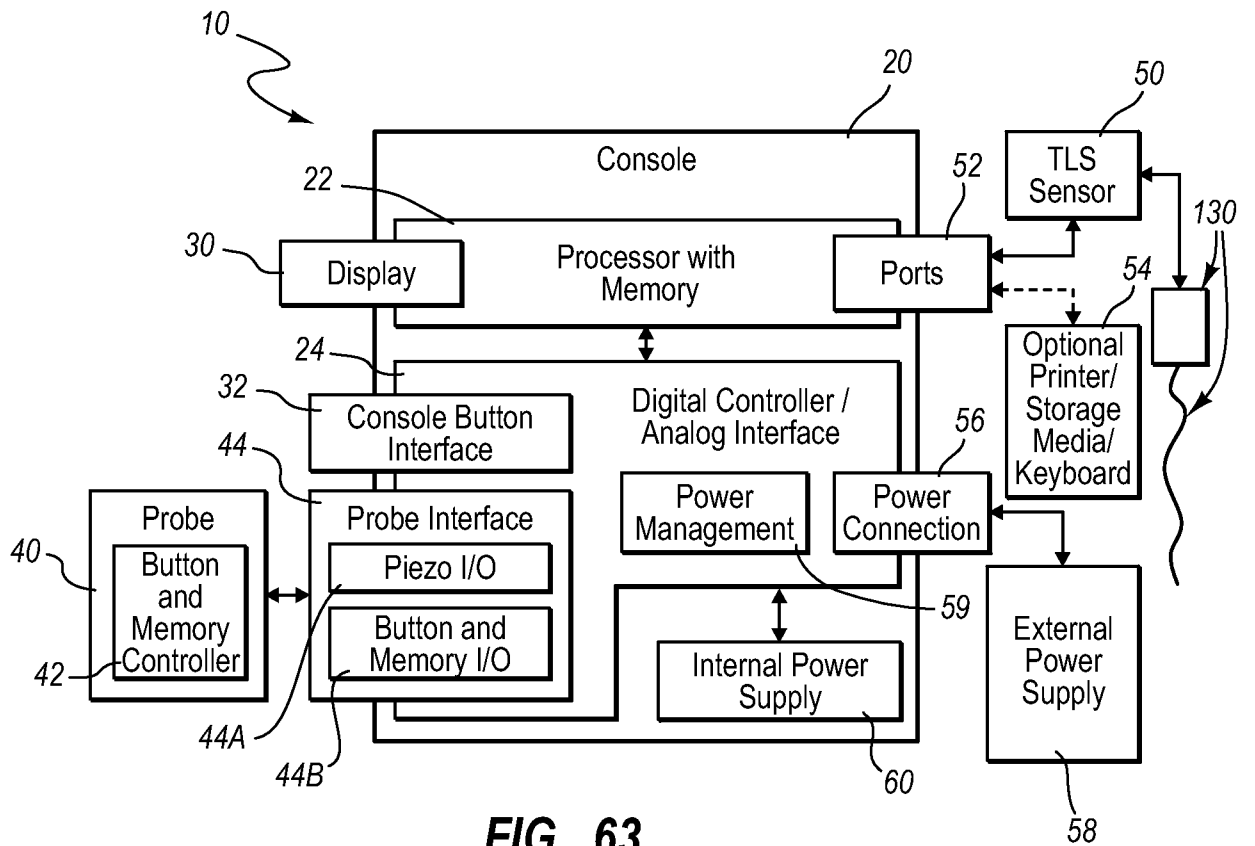

FIG. 63

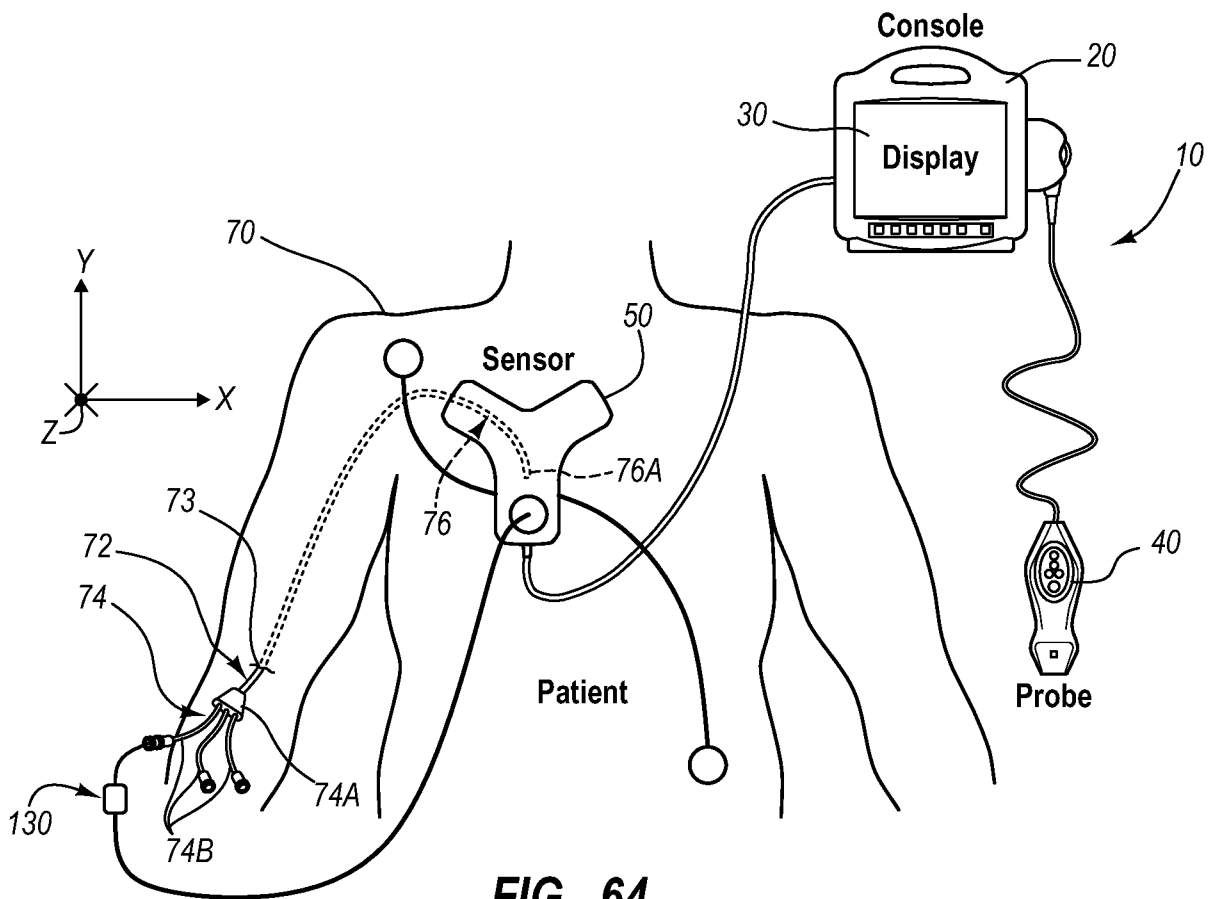

FIG. 64

50/57

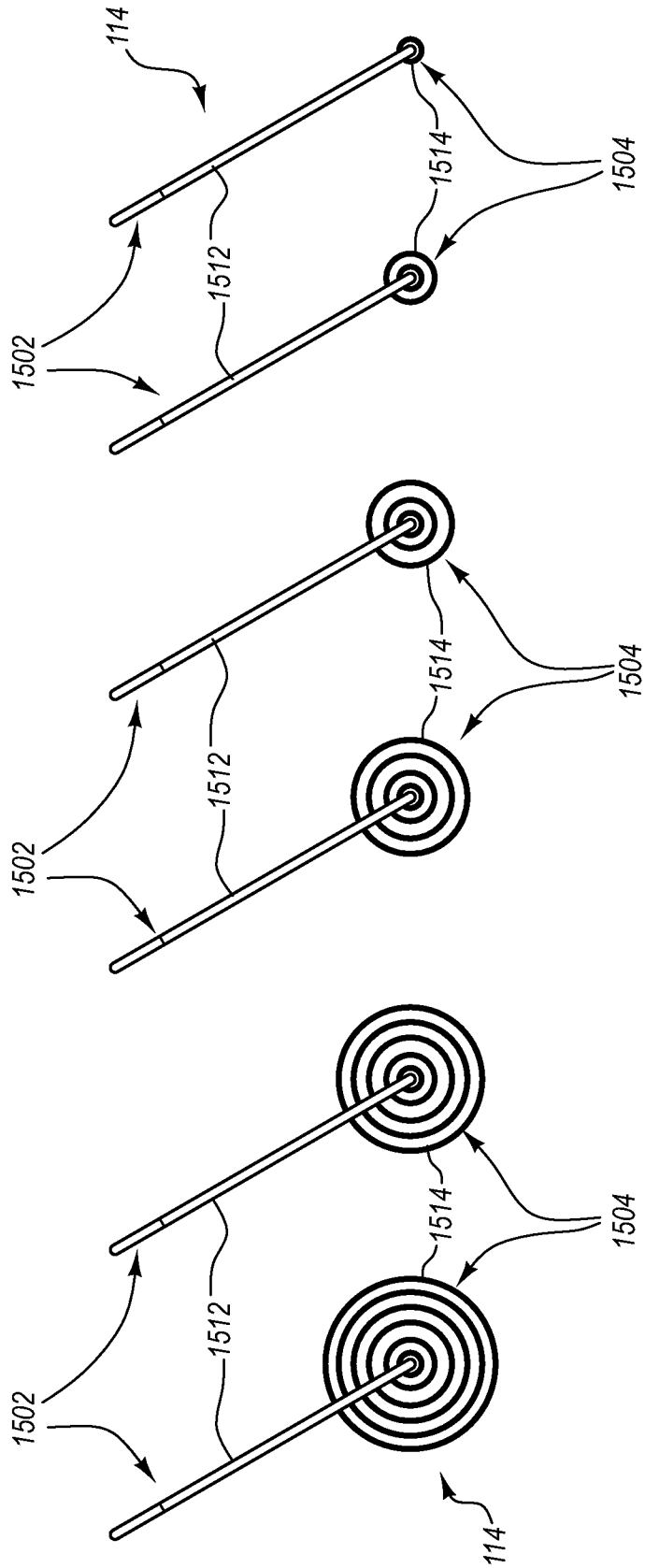

FIG. 65

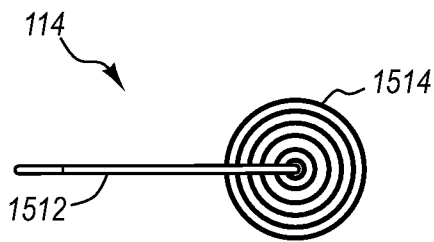
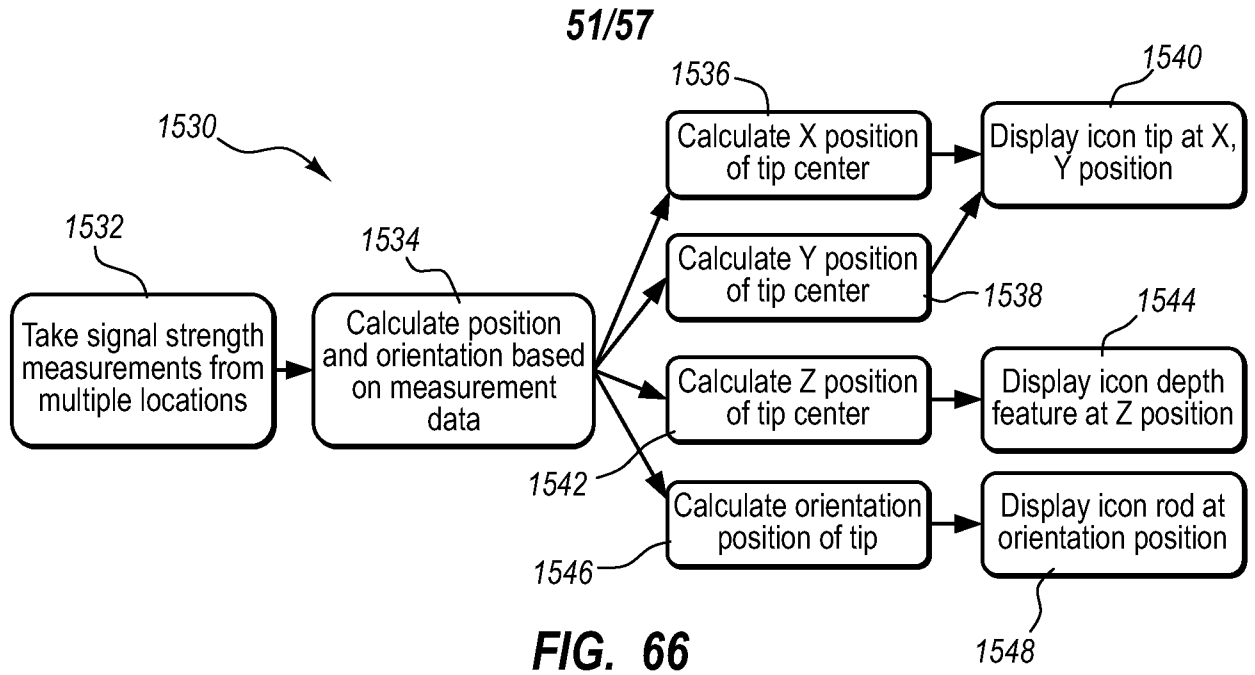

FIG. 67A

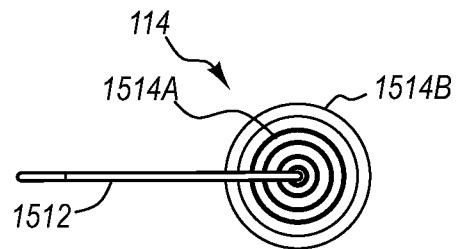

FIG. 67B

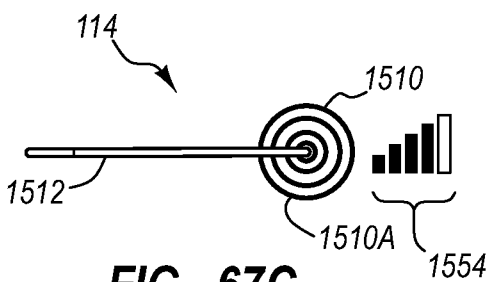

FIG. 67C

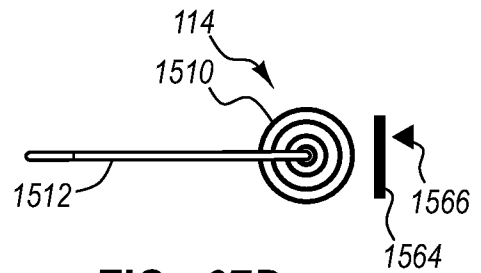

FIG. 67D

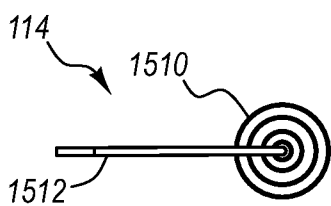

FIG. 67E

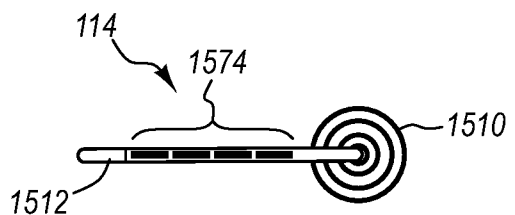

FIG. 67F

52/57

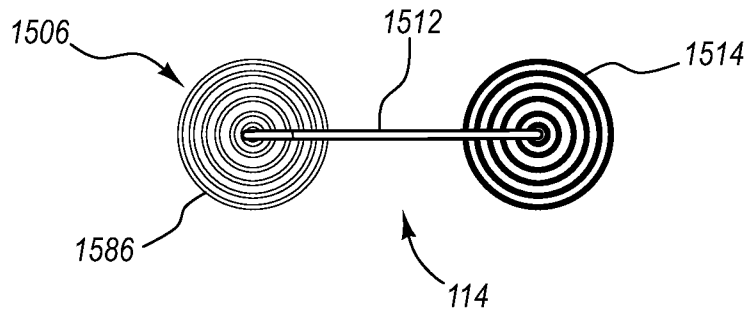

FIG. 68A

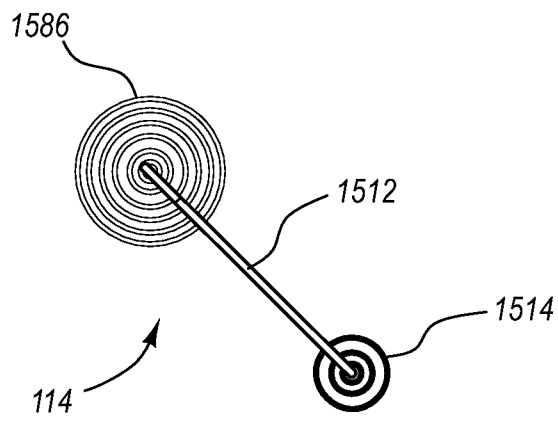

FIG. 68B

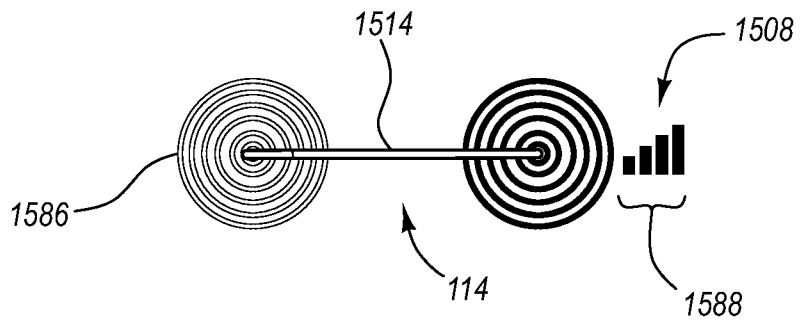

FIG. 69

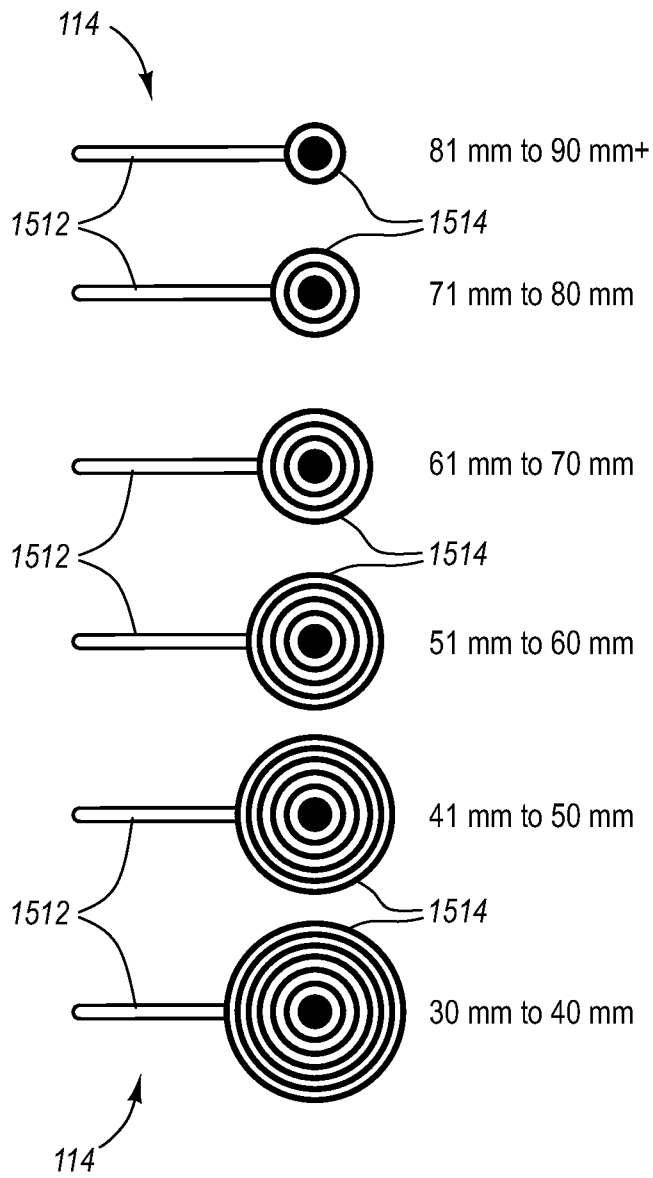

FIG. 70

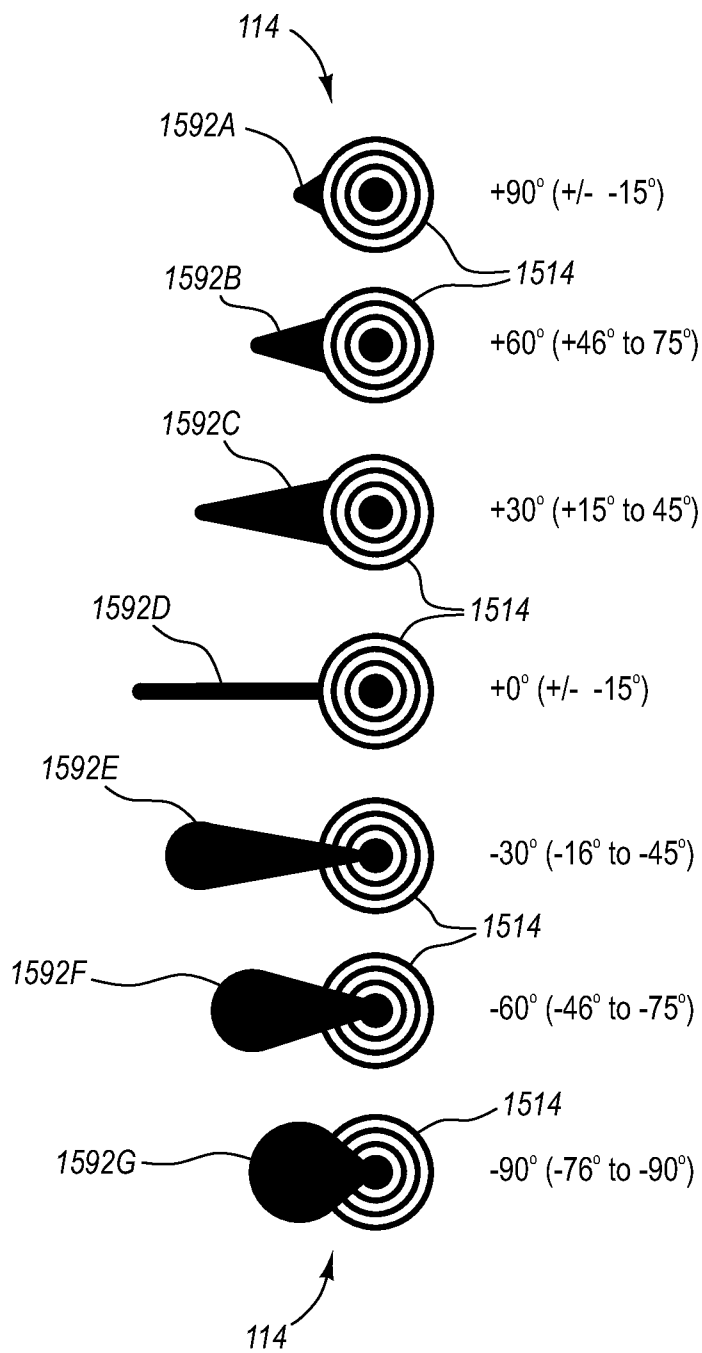

FIG. 71

55/57

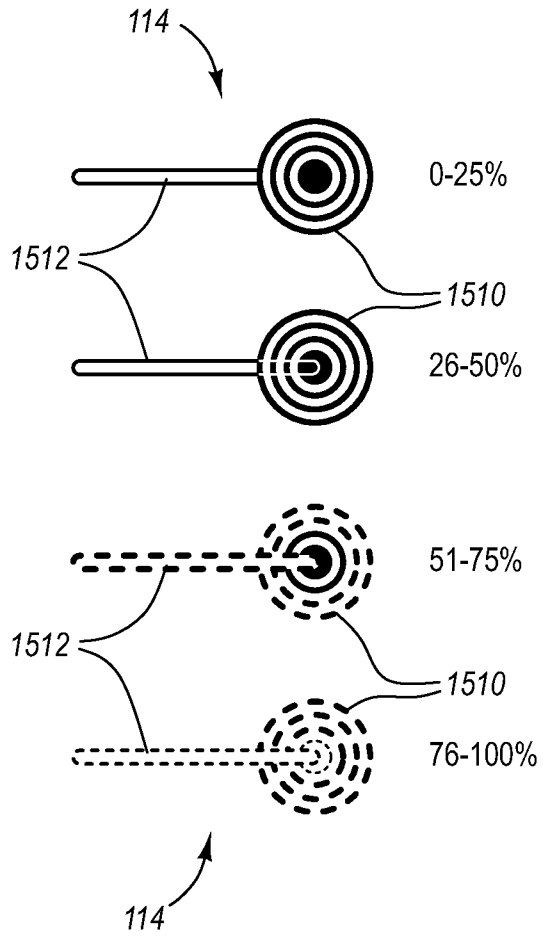

FIG. 72

56/57

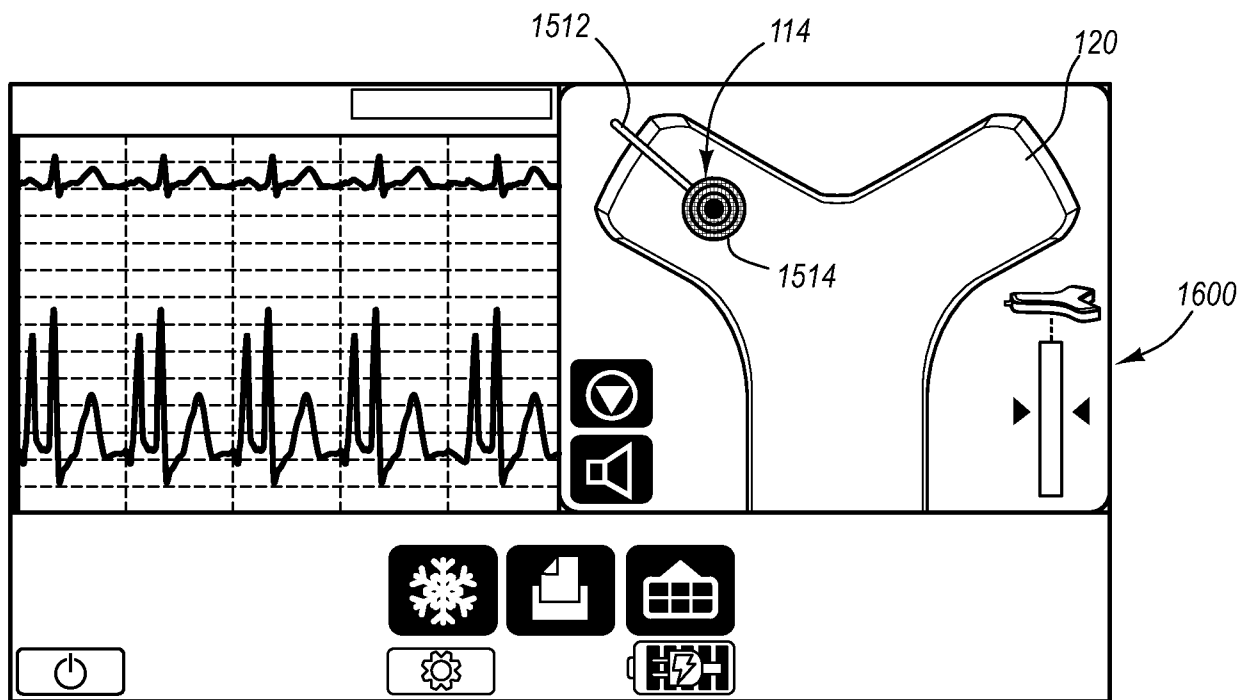

FIG. 73

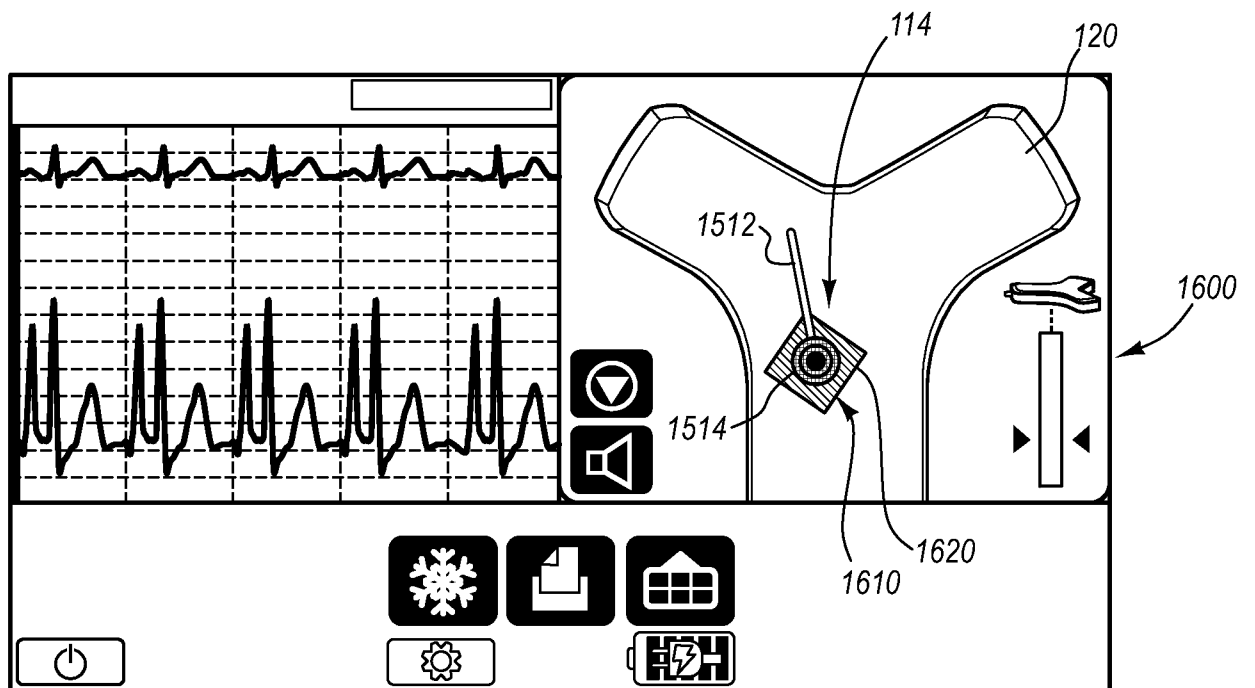

FIG. 74

57/57

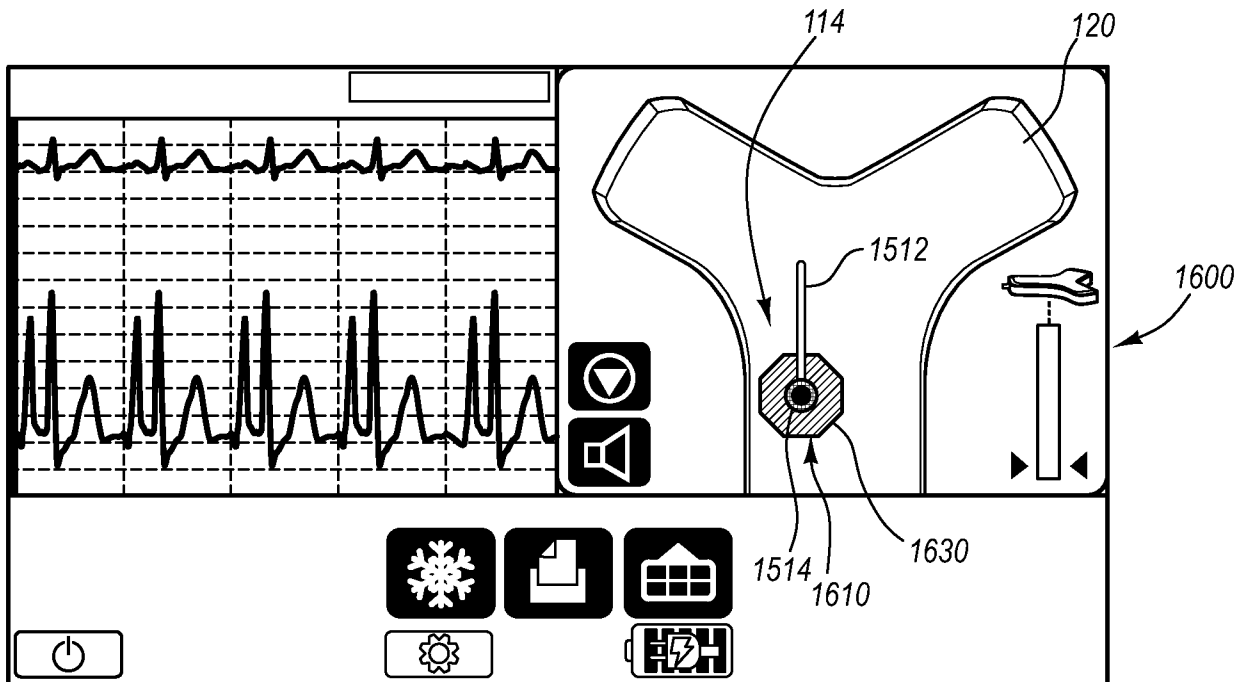

FIG. 75

INTERNATIONAL SEARCH REPORT

International application No.

PCT/US14/22019

A. CLASSIFICATION OF SUBJECT MATTER IPC(8) - A61B 5/05 (2014.01) USPC - 600/463 According to International Patent Classification (IPC) or to both national classification and IPC		
B. FIELDS SEARCHED Minimum documentation searched (classification system followed by classification symbols) IPC(8) - A61B 5/05 (2014.01) USPC - 600/463, 409, 462 Documentation searched other than minimum documentation to the extent that such documents are included in the fields searched Electronic data base consulted during the international search (name of data base and, where practicable, search terms used) MicroPatent (US-G, US-A, EP-A, EP-B, WO., JP-bib, DE-C.B, DE-A, DE-T, DE-U, GB-A, FR-A); Google Scholar; ProQuest Dialog; Medline/PubMed: 3D, angle, chart, color, confidence, diamond, display, ECG, EKG, error, graph, green, guide, icon, incline, indicate, locate, medical, monitor, octagon, pitch, place, plot, position, red, slope, statistic, symbol, uncertainty, vertical, three dimension		
C. DOCUMENTS CONSIDERED TO BE RELEVANT		
Category*	Citation of document, with indication, where appropriate, of the relevant passages	Relevant to claim No.
X --- Y	US 2012/0143029 A1 (SILVERSTEIN, FE, et al.) June 07, 2012; figures 4-7, 9, 10, 56; paragraphs [0018], [0019], [0099], [0100], [0111], [0114], [0115], [0120], [0121], [0124], [0171], [0182], [0182], [0306]	1-5, 7-9, 12-14, 16-23, 26 ----- 6, 10, 11, 15, 24, 25
Y	US 2011/0237935 A1 (KALPIN, SL, et al.) September 29, 2011; figure 23; paragraph [0174]	6, 24, 25
Y	US 2003/0073901 A1 (SIMON, DA, et al.) April 17, 2003; paragraph [0061]	10, 11
Y	US 2009/0005675 A1 (GRUNWALD, S, et al.) January 01, 2009; figure 8; paragraphs [0090], [0148], [0152]	11, 15
Y	US 2004/0138557 A1 (LE, TT, et al.) July 15, 2004; paragraphs [0073], [0076])	11
<input type="checkbox"/> Further documents are listed in the continuation of Box C. <input type="checkbox"/>		
* Special categories of cited documents: "A" document defining the general state of the art which is not considered to be of particular relevance "E" earlier application or patent but published on or after the international filing date "L" document which may throw doubts on priority claim(s) or which is cited to establish the publication date of another citation or other special reason (as specified) "O" document referring to an oral disclosure, use, exhibition or other means "P" document published prior to the international filing date but later than the priority date claimed "T" later document published after the international filing date or priority date and not in conflict with the application but cited to understand the principle or theory underlying the invention "X" document of particular relevance; the claimed invention cannot be considered novel or cannot be considered to involve an inventive step when the document is taken alone "Y" document of particular relevance; the claimed invention cannot be considered to involve an inventive step when the document is combined with one or more other such documents, such combination being obvious to a person skilled in the art "&" document member of the same patent family		
Date of the actual completion of the international search 22 May 2014 (22.05.2014)		Date of mailing of the international search report 11 JUN 2014
Name and mailing address of the ISA/US Mail Stop PCT, Attn: ISA/US, Commissioner for Patents P.O. Box 1450, Alexandria, Virginia 22313-1450 Facsimile No. 571-273-3201		Authorized officer: Shane Thomas PCT Helpdesk: 571-272-4300 PCT OSP: 571-272-7774

专利名称(译)	与放置医疗设备的系统有关的标志性表示		
公开(公告)号	EP2964085A1	公开(公告)日	2016-01-13
申请号	EP2014761249	申请日	2014-03-07
申请(专利权)人(译)	C.R. BARD , INC.		
当前申请(专利权)人(译)	C.R. BARD , INC.		
[标]发明人	MISENER ANTHONY KENT		
发明人	MISENER, ANTHONY, KENT		
IPC分类号	A61B5/05 A61B5/00		
CPC分类号	A61B5/0006 A61B5/042 A61B5/0452 A61B5/062 A61B5/743 A61B8/0841 G16H10/60 G16H20/40 G16H30/20 G16H30/40 G16H40/63 G16H50/20 G16H70/20		
优先权	61/775397 2013-03-08 US		
其他公开文献	EP2964085A4		
外部链接	Espacenet		

摘要(译)

公开了一种用于将导管精确地放置在患者脉管系统内的集成导管放置系统。在一个实施例中，集成系统包括系统控制台，用于临时放置在患者胸部上的尖端位置传感器，以及超声探头。当导管设置在脉管系统中时，尖端位置传感器感测设置在导管内腔中的探针的磁场。超声探头在引入导管之前对脉管系统的一部分进行超声成像。基于ECG信号的导管尖端引导包括在集成系统中，以使导管尖端能够相对于患者心脏的节点引导到期望的位置。还公开了用于描绘系统的显示并且涉及导管或医疗装置的位置和其他特征的图示表示。