

(19) World Intellectual Property Organization
International Bureau



(43) International Publication Date
21 April 2011 (21.04.2011)

PCT

(10) International Publication Number
WO 2011/046880 A2

(51) International Patent Classification:
A61B 8/00 (2006.01) A61B 6/00 (2006.01)
A61N 7/00 (2006.01)

(72) Inventor; and
(71) Applicant : GERTNER, Michael [US/US]; 520 Laurel Street, Menlo Park, CA 94025 (US).

(21) International Application Number:
PCT/US2010/052197

(74) Agent: CHAN, Gerald; Vista IP Law Group, LLP, 1885 Lundy Avenue, Suite 108, San Jose, CA 95131 (US).

(22) International Filing Date:
11 October 2010 (11.10.2010)

(81) Designated States (unless otherwise indicated, for every kind of national protection available): AE, AG, AL, AM, AO, AT, AU, AZ, BA, BB, BG, BH, BR, BW, BY, BZ, CA, CH, CL, CN, CO, CR, CU, CZ, DE, DK, DM, DO, DZ, EC, EE, EG, ES, FI, GB, GD, GE, GH, GM, GT, HN, HR, HU, ID, IL, IN, IS, JP, KE, KG, KM, KN, KP, KR, KZ, LA, LC, LK, LR, LS, LT, LU, LY, MA, MD, ME, MG, MK, MN, MW, MX, MY, MZ, NA, NG, NI, NO, NZ, OM, PE, PG, PH, PL, PT, RO, RS, RU, SC, SD, SE, SG, SK, SL, SM, ST, SV, SY, TH, TJ, TM, TN, TR, TT, TZ, UA, UG, US, UZ, VC, VN, ZA, ZM, ZW.

(25) Filing Language: English

(26) Publication Language: English

(30) Priority Data:
61/250,857 12 October 2009 (12.10.2009) US
61/256,983 31 October 2009 (31.10.2009) US
61/261,741 16 November 2009 (16.11.2009) US
61/291,359 30 December 2009 (30.12.2009) US
12/685,655 11 January 2010 (11.01.2010) US
61/303,307 10 February 2010 (10.02.2010) US
12/725,450 16 March 2010 (16.03.2010) US
61/347,375 21 May 2010 (21.05.2010) US
61/377,908 27 August 2010 (27.08.2010) US

(84) Designated States (unless otherwise indicated, for every kind of regional protection available): ARIPO (BW, GH, GM, KE, LR, LS, MW, MZ, NA, SD, SL, SZ, TZ, UG, ZM, ZW), Eurasian (AM, AZ, BY, KG, KZ, MD, RU, TJ, TM), European (AL, AT, BE, BG, CH, CY, CZ, DE, DK, EE, ES, FI, FR, GB, GR, HR, HU, IE, IS, IT, LT, LU, LV, MC, MK, MT, NL, NO, PL, PT, RO, RS, SE, SI, SK, SM, TR), OAPI (BF, BJ, CF, CG, CI, CM, GA, GN, GQ, GW, ML, MR, NE, SN, TD, TG).

(71) Applicant (for all designated States except US): KONA MEDICAL, INC. [US/US]; 335 Bryant Street, Palo Alto, CA 94301 (US).

[Continued on next page]

(54) Title: ENERGETIC MODULATION OF NERVES

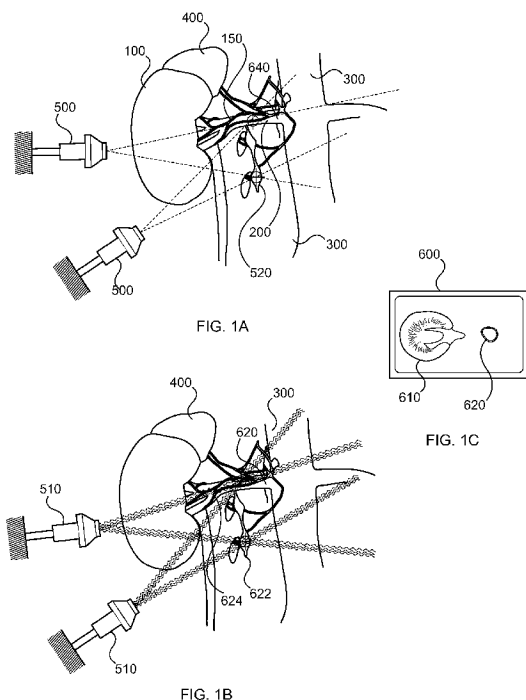

(57) Abstract: In some examples, nerves surrounding arteries or leading to organs are targeted with energy sources to correct or modulate physiologic processes. In some examples, different types of energy sources are utilized singly or combined with one another. In some examples, bioactive agents or devices activated by the energy sources are delivered to the region of interest and the energy is enhanced by such agents or the agents are enhanced by the energy sources.

WO 2011/046880 A2

Published:

- *without international search report and to be republished upon receipt of that report (Rule 48.2(g))*

Energetic Modulation of Nerves**PRIORITY DATA**

5 This applications claims priority to and incorporates by reference,
the following applications:

U.S. Patent application 12/725450 filed March 16, 2010

U.S. Patent application 12/685655 filed January 11, 2010

U.S. Provisional patent application 61/250857 filed October 12, 2009

10 U.S. Provisional patent application 61/256983 filed October 31, 2009

U.S. Provisional patent application 61/261741 filed November 16, 2009

U.S. Provisional patent application 61/291359 filed December 30, 2009

U.S. Provisional patent application 61/303307 filed February 10, 2010

U.S. Provisional patent application 61/347375 filed May 21, 2010

15 U.S. Provisional patent application 61/377908 filed August 27 2010

The following patent applications are also expressly incorporated by
reference herein.

20 U.S. Patent Application Nos. 11/583569, 12/762938, 11/583656,
12/247969, 10/633726, 09/721526, 10/780405, 09/747310, 12/202195,
11/619996, 09/696076, 11/016701, 12/887,178, 12/390975, 12/887178,
12/887211, 12/887232

It should be noted that the subject matters of the above applications
and any other applications referenced herein are expressly
25 incorporated into this application as if they are expressly recited in

this application. Thus, in the instance where the references are not specifically labeled as "incorporated by reference" in this application, they are in fact deemed described in this application.

5 Background

Energy delivery from a distance involves transmission of energy waves to affect a target at a distance. It allows for more efficient delivery of energy to targets and a greater cost efficiency and technologic flexibility on the generating side. For example, cellular phones receive targets from towers close to the user and the towers communicate with one another over a long range; this way, the cell phones can be low powered and communicate over a relatively small range yet the network can quickly communicate across the world. Similarly, electricity distribution from large generation stations to the users is more efficient than the users themselves looking for solutions.

In terms of treating a patient, delivering energy over a distance affords great advantages as far as targeting accuracy, technologic flexibility, and importantly, limited invasiveness into the patient. In a simple form, laparoscopic surgery has replaced much of the previous open surgical procedures and lead to creation of new procedures and devices as well as a more efficient procedural flow for disease treatment. Laparoscopic tools deliver the surgeon's energy to the tissues of the patient from a distance and results in improved imaging of the region being treated as well as the ability for many surgeons to visualize the region at the same time.

Perhaps the most important aspect is the fact that patients have much less pain, fewer complications, and the overall costs of the procedures are lower. Visualization is improved as is the ability to perform tasks relative to the visualization.

Continued advances in computing, miniaturization and economization of energy delivery technologies, and improved imaging will lead to still greater opportunities to apply energy from a distance into the patient and treat disease.

5 **Summary**

In some embodiments, procedures and devices are provided, which advance the art of medical procedures involving transmitted energy to treat disease. The procedures and devices follow along the lines of:
1) transmitting energy to produce an effect in a patient from a
10 distance; 2) allowing for improved imaging or targeting at the site of treatment; 3) creating efficiencies through utilization of larger and more powerful devices from a position of distance from or within the patient as opposed to attempting to be directly in contact with the target as a surgeon, interventional cardiologist or radiologist might
15 do. In many cases, advanced visualization and localization tools are utilized as well.

In some embodiments, a method of treatment includes placing an energy source outside a patient, operating the energy source so that an
20 energy delivery path of the energy source is aimed towards a nerve inside the patient, wherein the nerve is a part of an autonomic nervous system, and using the energy source to deliver treatment energy from outside the patient to the nerve located inside the patient to treat the nerve.

25 In some embodiments, the treatment energy comprises focused energy.

In some embodiments, the treatment energy comprises non-focused energy.

30 In some embodiments, the treatment energy comprises HIFU energy.

In some embodiments, the treatment energy comprises LIFU energy.

In some embodiments, the treatment energy is delivered to the nerve to achieve partial ablation of the nerve.

5

In some embodiments, the treatment energy is delivered to the nerve to achieve complete ablation of the nerve.

10 In some embodiments, the treatment energy is delivered to achieve paralysis of the nerve.

In some embodiments, the nerve leads to a kidney.

In some embodiments, the nerve comprises a renal nerve.

15

In some embodiments, the nerve comprises a sympathetic nerve connected to the kidney.

20 In some embodiments, the nerve comprises an afferent nerve connected to the kidney.

In some embodiments, the nerve comprises a renal sympathetic nerve at a renal pedicle.

25 In some embodiments, the nerve comprises a nerve trunk adjacent to a vertebra.

In some embodiments, the nerve comprises a ganglion adjacent to a vertebra.

30

In some embodiments, the nerve comprises a dorsal root nerve.

In some embodiments, the nerve leads to an adrenal gland.

In some embodiments, the nerve comprises a motor nerve.

In some embodiments, the nerve is next to a kidney.

5 In some embodiments, the nerve is behind an eye.

In some embodiments, the nerve comprises a celiac plexus.

In some embodiments, the nerve is within or around a vertebral column.

10

In some embodiments, the nerve extends to a facet joint

In some embodiments, the nerve comprises a celiac ganglion.

15 In some embodiments, the act of operating the energy source comprises positioning the energy source.

In some embodiments, the energy source comprises an ultrasound energy source.

20

In some embodiments, the ultrasound energy source is used to deliver the treatment energy to the nerve from multiple directions outside the patient.

25 In some embodiments, the treatment energy is delivered to modulate the nerve without damaging the nerve.

In some embodiments, the method further includes determining a position of a renal vessel using an imaging device located outside the
30 patient.

In some embodiments, the position of the renal vessel is used to determine a position of the nerve.

In some embodiments, the imaging device comprises a CT device, an MRI device, a thermography device, an infrared imaging device, an optical coherence tomography device, a photoacoustic imaging device, a PET imaging device, a SPECT imaging device, or an ultrasound device.

5

In some embodiments, the method further includes determining a position of the nerve inside the patient.

10 In some embodiments, the act of determining the position of the nerve inside the patient comprises determining a position of a renal vessel to target the nerve that surrounds the renal vessel.

In some embodiments, the renal vessel comprises a renal artery.

15 In some embodiments, the act of determining the position of the nerve inside the patient comprises using a Doppler triangulation technique.

In some embodiments, the imaging device comprises a MRI device.

20 In some embodiments, the imaging device comprises a CT device.

In some embodiments, the treatment energy comprises HIFU energy, and the imaging device comprises a MRI device.

25 In some embodiments, the treatment energy comprises HIFU energy, and the imaging device comprises an ultrasound device.

In some embodiments, the nerve leads to a kidney, and the imaging device comprises a MRI device.

30

In some embodiments, the nerve leads to a kidney, and the imaging device comprises an ultrasound device.

In some embodiments, the nerve leads to a kidney, and the imaging device is used to obtain a doppler signal.

5 In some embodiments, the treatment energy is delivered to a kidney to decrease a sympathetic stimulus to the kidney, decrease an afferent signal from the kidney to an autonomic nervous system, or both.

10 In some embodiments, the method further includes delivering testing energy to the patient to determine if there is a reaction resulted therefrom, wherein the testing energy is delivered before the treatment energy is delivered from the energy source.

15 In some embodiments, the testing energy comprises heat or vibratory energy, and the method further comprises performing a test to detect sympathetic nerve activity.

20 In some embodiments, the testing energy comprises a stimulus applied to a skin, and the method further comprises detecting an output from the patient.

In some embodiments, the output comprises a heart rate.

25 In some embodiments, the test energy is delivered to stimulate a baroreceptor complex, and the method further includes applying pressure to a carotid artery, and determining whether a blood pressure decreases after application of the pressure to the carotid artery.

30 In some embodiments, the test energy is delivered using an ultrasound device that is placed outside the patient.

In some embodiments, the treatment energy from the energy source is delivered if the blood pressure decreases or if the blood pressure decreases at a rate that is above a prescribed threshold.

In some embodiments, the treatment energy is delivered to treat hypertension.

5 In some embodiments, the treatment energy is delivered to treat glaucoma.

10 In some embodiments, the energy source is operated so that the energy source aims at a direction that aligns with a vessel that is next to the nerve.

In some embodiments, the method further includes tracking a movement of a treatment region containing the nerve.

15 In some embodiments, the energy delivery path of the energy source is aimed towards the nerve by using a position of a blood vessel that is surrounded by the nerve.

20 In some embodiments, the method further includes delivering a device inside the patient, and using the device to determine a position of the nerve inside the patient, wherein the energy source is operated based at least in part on the determined position so that the energy delivery path is aimed towards the nerve.

25 In some embodiments, the device is placed inside a vessel that is surrounded by the nerve, and the position of the nerve is determined indirectly by determining a position of the vessel.

30 In some embodiments, a system for treatment includes an energy source for placement outside a patient, wherein the energy source is configured to aim an energy delivery path towards a nerve that is a part of an autonomic nervous system inside the patient, and wherein the energy source is configured to deliver treatment energy from outside the patient to the nerve located inside the patient to treat the nerve.

In some embodiments, the energy source is configured to provide focused energy.

5 In some embodiments, the energy source is configured to provide non-focused energy.

In some embodiments, the energy source is configured to provide HIFU energy.

10

In some embodiments, the energy source is configured to provide LIFU energy.

15 In some embodiments, the energy source is configured to provide the treatment energy to achieve partial ablation of the nerve.

In some embodiments, the energy source is configured to deliver the treatment energy to achieve complete ablation of the nerve.

20 In some embodiments, the energy source is configured to deliver the treatment energy to achieve paralysis of the nerve.

In some embodiments, the energy source comprises an ultrasound energy source.

25

In some embodiments, the ultrasound energy source is configured to deliver the treatment energy to the nerve from multiple directions outside the patient while the ultrasound energy source is stationary relative to the patient.

30

In some embodiments, the energy source is configured to deliver the treatment energy to modulate the nerve without damaging tissues that are within a path of the treatment energy to the nerve.

In some embodiments, the nerve comprises a renal nerve, and the system further includes a processor located outside the patient, wherein the processor is configured for receiving an input related to a position of a renal artery, determining an output related to a position of the renal nerve based on a model that associates artery position with
5 nerve position, and providing the output to a positioning system for the energy source so that the positioning system can cause the energy source to deliver the treatment energy from the outside of the patient to the renal nerve to treat the renal nerve.

10

In some embodiments, the system further includes a processor for determining a position of a renal vessel located outside the patient.

In some embodiments, the system further includes an imaging device for
15 providing an image signal, wherein the processor is configured to determine the position based on the image signal.

In some embodiments, the imaging device comprises a CT device, a MRI device, a thermography device, an infrared imaging device, an optical
20 coherence tomography device, a photoacoustic imaging device, a PET imaging device, a SPECT imaging device, or an ultrasound device.

In some embodiments, the position of the renal vessel is used during the treatment energy delivery to target the nerve that surrounds the
25 renal vessel.

In some embodiments, the position is determined using a Doppler triangulation technique.

30 In some embodiments, the renal vessel comprises a renal artery.

In some embodiments, treatment energy is delivered to a kidney to decrease a sympathetic stimulus to the kidney, decrease an afferent signal from the kidney to an autonomic nervous system, or both.

In some embodiments, the energy source is also configured to deliver testing energy to the patient to determine if there is a reaction resulted therefrom.

5

In some embodiments, the energy source is configured to deliver the treatment energy to treat hypertension.

10 In some embodiments, the energy source is configured to deliver the treatment energy to treat glaucoma.

In some embodiments, the energy source has an orientation so that the energy source aims at a direction that aligns with a vessel that is next to the nerve.

15

In some embodiments, the energy source is configured to track a movement of the nerve.

20 In some embodiments, the energy source is configured to track the movement of the nerve by tracking a movement of a blood vessel next to the nerve.

In some embodiments, the energy source is configured to aim at the nerve by aiming at a vessel that is surrounded by the nerve.

25

In some embodiments, the system further includes a device for placement inside the patient, and a processor for determining a position using the device, wherein the energy source is configured to aim the energy delivery path towards the nerve inside the patient
30 based at least in part on the determined position.

In some embodiments, the device is sized for insertion into a vessel that is surrounded by the nerve.

In some embodiments, a system to deliver energy from a position outside a skin of a patient to a nerve surrounding a blood vessel inside the patient, includes a processor configured to receive image signal, and determine a three dimensional coordinate of a blood vessel
5 based on the image signal, and an energy source configured to deliver energy from the position outside the skin of the patient to the nerve surrounding the blood vessel, wherein the processor is also configured to control the energy source based on the determined coordinate.

10 In some embodiments, the system further includes an imaging device for providing the image signal.

In some embodiments, the imaging device comprises a MRI device.

15 In some embodiments, the imaging device comprises an ultrasound device.

In some embodiments, the energy comprises focused energy.

20 In some embodiments, the energy comprises focused ultrasound.

In some embodiments, the energy source comprises an ultrasound array that is aligned with the vessel.

25 In some embodiments, the system further includes an imaging device for providing a B-mode ultrasound for imaging the blood vessel.

In some embodiments, a system to deliver energy from a position outside a skin of a patient to a nerve surrounding a blood vessel
30 includes a fiducial for placement inside the blood vessel, a detection device to detect the fiducial inside the blood vessel, a processor configured to determine a three dimensional coordinate of the detected fiducial, and an energy source configured to transmit energy through the skin and to focus the energy at the region of the blood vessel,

wherein the processor is configured to operate the energy source based on the determined three dimensional coordinate of the fiducial, and information regarding the blood vessel.

5 In some embodiments, the energy source comprises an ultrasound device, and wherein the blood vessel is a renal artery.

In some embodiments, the system further includes an ultrasound imaging system.

10

In some embodiments, the fiducial is placed inside the blood vessel and is attached to an intravascular catheter.

15 In some embodiments, the fiducial is a passive fiducial that is configured to respond to an external signal.

In some embodiments, the fiducial is an active fiducial, transmitting its position to the detection device.

20 In some embodiments, a method to treat hypertension in a patient includes obtaining an imaging signal from a blood vessel in the patient, planning a delivery of energy to a wall of the blood vessel, and delivering energy from outside a skin of the patient to an autonomic nerve surrounding the blood vessel.

25

In some embodiments, the method further includes selectively modulating an afferent nerve within a sympathetic nerve bundle.

30 In some embodiments, the method further includes utilizing microneurography after the delivery of the energy to determine an effect of the energy delivery on a sympathetic nervous system.

In some embodiments, the blood vessel extends to or from a kidney, and the method further comprises locating the blood vessel with doppler ultrasound.

5 In some embodiments, a system to modulate an autonomic nerve in a patient utilizing transcutaneous energy delivery, the system includes a processor comprising an input for receiving information regarding energy and power to be delivered to a treatment region containing the nerve, and an output for outputting a signal, wherein the processor is
10 configured to determine a position of a reference target from outside the patient to localize the nerve relative to the reference target, a therapeutic energy device comprising a transducer for delivering energy from outside the patient, a controller to control an aiming of the transducer based at least in part on the signal from the
15 processor, and an imaging system coupled to the processor or the therapeutic energy device.

In some embodiments, the processor is configured to determine the position during an operation of the therapeutic energy device.

20 In some embodiments, the system further includes a patient interface configured to position the therapeutic device so that the transducer is aimed toward a blood vessel connected to a kidney from a position between ribs superiorly, a iliac crest inferiorly, and a vertebral
25 column medially.

In some embodiments, the therapeutic energy device is configured to deliver focused ultrasound.

30 In some embodiments, the reference target is at least a portion of a blood vessel traveling to or from a kidney, and the nerve is a renal nerve.

In some embodiments, the transducer is configured to focus energy at a distance from 6 cm to 18 cm.

5 In some embodiments, the transducer is configured to deliver the energy in a form of focused ultrasound to a renal blood vessel at an angle ranging between about -10 degrees and about -48 degrees relative to a horizontal line connecting transverse processes of a spinal column.

10 In some embodiments, the energy from the therapeutic energy device ranges between 100 W/cm² and 2500 W/cm².

In some embodiments, the reference target is an indwelling vascular catheter.

15 In some embodiments, the imaging system is a magnetic resonance imaging system and the therapeutic energy device is an ultrasound device.

20 In some embodiments, the imaging system is an ultrasound imaging system.

In some embodiments, the processor is a part of the therapeutic energy device.

25 In some embodiments, the processor is a part of the imaging system.

In some embodiments, a method to deliver energy from a position outside the skin of a patient to a nerve surrounding a blood vessel, 30 includes placing a device inferior to ribs, superior to an iliac crest, and lateral to a spine, and using the device to maintain an energy delivery system at a desired position relative to the patient so that the energy delivery system can deliver energy through the skin without traversing bone.

In some embodiments, the energy delivery system comprises a focused ultrasound delivery system.

5 In some embodiments, a device for use in a system to deliver focused ultrasound energy from a position outside a skin of a patient to a nerve surrounding a blood vessel, includes a positioning device configured to maintain an energy delivery system at a desired position relative to the patient so that the energy delivery system can deliver
10 energy through the skin without traversing bone, wherein the positioning device is configured to be placed inferior to ribs, superior to an iliac crest, and lateral to a spine.

In some embodiments, the energy delivery system comprises a focused
15 ultrasound delivery system.

In some embodiments, the positioning device is configured to maintain an angle of the focused ultrasound delivery system such that bony structures are not include in an ultrasound field .

20 In some embodiments, a system for treatment includes a treatment device configured to deliver energy from outside a patient to a nerve inside the patient, a catheter configured for placement inside a vessel surrounded by the nerve, the catheter configured to transmit a
25 signal, and a processor configured to receive the signal and determine a reference position in the vessel, wherein the treatment device is configured deliver the energy to the nerve based on the determined reference position.

30 In some embodiments, the treatment device comprises an ultrasound device.

In some embodiments, a method of inhibiting the function of a nerve traveling with an artery includes providing an external imaging

modality to determine the location of the artery of a patient, placing the artery in a first three dimensional coordinate reference based on the imaging, placing or associating a therapeutic energy generation source in the first three dimensional coordinate reference frame, modeling the delivery of energy to the adventitial region of the artery or a region adjacent to the artery where a nerve travels, delivering therapeutic energy from the therapeutic energy source, from at least two different angles, through the skin of a patient, to intersect at the artery or the region adjacent to the artery, and at least partially inhibiting the function of the nerve traveling with the artery.

In some embodiments, the imaging modality is one of: ultrasound, MRI, and CT.

In some embodiments, the therapeutic energy is ultrasound.

In some embodiments, the artery is a renal artery.

In some embodiments, placing the artery in a three dimensional reference frame comprises locating the artery using a doppler ultrasound signal.

In some embodiments, the method further includes utilizing a fiducial wherein the fiducial is placed internal to the patient.

In some embodiments, said fiducial is temporarily placed in a position internal to the patient.

In some embodiments, said fiducial is a catheter placed in the artery of the patient.

In some embodiments, said catheter is detectable using a radiofrequency signal and said imaging modality is ultrasound.

In some embodiments, the therapeutic energy from the energy source is delivered in a distribution along the length of the artery.

5 In some embodiments, the therapeutic energy is ionizing radiation.

In some embodiments, a system to inhibit the function of a nerve traveling with a renal artery includes a detector to determine the location of the renal artery and renal nerve from a position external
10 to a patient, an ultrasound component to deliver therapeutic energy through the skin from at least two directions to the nerve surrounding the renal artery, a modeling algorithm comprising an input and an output, said input to the modeling algorithm comprising a three dimensional coordinate space containing a therapeutic energy source
15 and the position of the renal artery in the three dimensional coordinate space, and said output from the modeling algorithm comprising the direction and energy level of the ultrasound component, a fiducial, locatable from a position outside a patient, adapted to be temporarily placed in the artery of the patient and communicate with
20 the detector to determine the location of the renal artery in a three dimensional reference frame, the information regarding the location transmittable as the input to the model.

In some embodiments, the fiducial is a passive reflector of
25 ultrasound.

In some embodiments, the fiducial generates radiofrequency energy.

In some embodiments, the fiducial is activated to transmit energy
30 based on a signal from an ultrasound or magnetic field generator.

In some embodiments, the output from the model instructs the ultrasound component to deliver a lesion on the artery in which the

major axis of the lesion is longitudinal along the length of the artery.

In some embodiments, the output from the model instructs the
5 ultrasound component to deliver multiple lesions around an artery simultaneously.

In some embodiments, the output from the model instructs the
10 ultrasound component to deliver a circumferential lesion around the artery.

In some embodiments, the lesion is placed around the renal artery just proximal to the bifurcation of the artery in the hilum of the kidney.

15 In some embodiments, a method to stimulate or inhibit the function of a nerve traveling to or from the kidney includes identifying an acoustic window at the posterior region of a patient in which the renal arteries can be visualized, transmitting a first energy through the skin of a patient from the posterior region of the patient,
20 imaging an arterial region using the first transmitted energy, and applying a second transmitted energy to the arterial adventitia by coupling the imaging and the second transmitted energy.

In some embodiments, the method further includes tracking the image
25 created by the first transmitted energy.

In some embodiments, a method to locate the position of a blood vessel in the body of a patient includes applying a first wave of ultrasound, from a first direction, to a region of a blood vessel from outside of
30 the patient and detecting its return signal, comparing the applied first wave and its return signal, simultaneously, or sequentially, applying a second wave of ultrasound from a second direction to the blood vessel and detecting a its return signal, and integrating the return signals from the first wave and the return signals from the

second wave to determine the position, in a three dimensional coordinate reference, of the blood vessel.

In some embodiments, the method further includes the step of
5 instructing a therapeutic ultrasound transducer to apply energy to the position of the blood vessel.

Description of Figures

Figures 1a-b depict the focusing of energy sources on nerves of the autonomic nervous system.

5 Figure 1c depicts an imaging system to help direct the energy sources.

Figure 2 depicts targeting and/or therapeutic ultrasound delivered through the stomach to the autonomic nervous system posterior to the stomach.

Figure 3a depicts focusing of energy waves on the renal nerves.

10 Figure 3b depicts a coordinate reference frame for the treatment.

Figure 3C depicts targeting catheters placed in any of the renal vessels.

Figure 3D depicts an image detection system of a blood vessel with a temporary fiducial placed inside.

15 Figure 3E depicts a therapy paradigm for the treatment and assessment of hypertension.

Figure 4a depicts the application of energy to the autonomic nervous system surrounding the carotid arteries.

20 Figure 4B depicts the application of energy to through the vessels of the renal hilum.

Figs 5a-b depicts the application of focused energy to the autonomic nervous system of the eye.

Fig. 6 depicts the application of constricting lesions to the kidney deep inside the calyces of the kidney.

25 Figures 7a depicts a patient in an imaging system receiving treatment with focused energy waves.

Figure 7b depicts visualization of a kidney being treated.

Figure 7c depicts a close up view of the renal nerve region of the kidney being treated.

Figure 7d depicts an algorithmic method to treat the autonomic nervous system using MRI and energy transducers.

- 5 Figure 7e depicts a geometric model obtained from cross-sectional images of the area of the aorta and kidneys.

Figure 7F depicts a close up image of the region of treatment.

Figure 7G depicts the results of measurements from a series of cross sectional image reconstructions.

- 10 Figure 7H depicts the results of measurements from a series of cross-sectional images from a patient in a more optimized position.

Figure 7I depicts an algorithmic methodology to apply treatment to the hilum of the kidney and apply energy to the renal blood vessels.

- 15 Figure 8a depicts a percutaneous approach to treating the autonomic nervous system surrounding the kidneys.

Figure 8b depicts an intravascular approach to treating or targeting the autonomic nervous system.

Figure 8C depicts a percutaneous approach to the renal hila using a CT scan and a probe to reach the renal blood vessels.

- 20 Figures 9a-c depicts the application of energy from inside the aorta to regions outside the aorta to treat the autonomic nervous system.

Figure 10 depicts steps to treat a disease using HIFU while monitoring progress of the treatment as well as motion.

- 25 Figure 11a depicts treatment of brain pathology using cross sectional imaging.

Figure 11b depicts an image on a viewer showing therapy of the region of the brain being treated.

Figure 11c depicts another view of a brain lesion as might be seen on an imaging device which assists in the treatment of the lesion.

Figure 12 depicts treatment of the renal nerve region using a laparoscopic approach.

- 5 Figure 13 depicts a methodology for destroying a region of tissue using imaging markers to monitor treatment progress.

Figure 14 depicts the partial treatment of portions of a nerve bundle using converging imaging and therapy wave.

- 10 Figure 15a-b depicts the application of focused energy to the vertebral column to treat various spinal pathologies including therapy of the spinal or intravertebral nerves.

Figure 16A depicts the types of lesions which are created around the renal arteries to affect a response.

- 15 Figure 16B depicts a simulation of ultrasound around a blood vessel I support of Figure 16A.

Figure 16C depicts data from ultrasound energy applied to the renal blood vessels and the resultant change in norepinephrine levels.

Figure 17A depicts the application of multiple transducers to treat regions of the autonomic nervous system at the renal hilum.

- 20 Figures 17B-C depict methods for using imaging to direct treatment of a specific region surrounding an artery as well as display the predicted lesion morphology.

Figure 17D depicts a method for localizing HIFU transducers relative to Doppler ultrasound signals.

- 25 Figure 17E depicts an arrangement of transducers relative to a target.

Figure 17F depicts ablation zones in a multi-focal region in cross-section.

Figure 18 depicts the application of energy internally within the kidney to affect specific functional changes at the regional level within the kidney.

5 Figure 19A depicts the direction of energy wave propagation to treat regions of the autonomic nervous system around the region of the kidney hilum.

Figure 19B depicts a schematic of a B mode ultrasound from a direction determined through experimentation to provide access to the renal hilum with HIFU.

10 Figure 20 depicts the application of ultrasound waves through the wall of the aorta to apply a therapy to the autonomic nervous system.

Figure 21A depicts application of focused energy to the ciliary muscles and processes of the anterior region of the eye.

15 Figure 21B depicts the application of focused non-ablative energy to the back of the eye to enhance drug or gene delivery or another therapy such as ionizing radiation.

Figure 22 depicts the application of focused energy to nerves surrounding the knee joint to affect nerve function in the joint.

20 Figures 23A-B depicts the application of energy to the fallopian tube to sterilize a patient.

Figure 24 depicts an algorithm to assess the effect of the neural modulation procedure on the autonomic nervous system. After a procedure is performed on the renal nerves, assessment of the autonomic response is performed by, for example, simulating the
25 autonomic nervous system in one or more places.

Figure 25 depicts an optimized position of a device to apply therapy to internal nerves.

Figure 26A depicts positioning of a patient to obtain parameters for system design.

Figure 26B depicts a device design based on the information learned from feasibility studies.

Figure 27 depicts a clinical paradigm for treating the renal nerves of the autonomic nervous system based on feasibility studies.

- 5 Figure 28 A-C depicts a treatment positioning system for a patient incorporating a focused ultrasound system.

Figure 29 A-D depicts results of studies applying focused energy to nerves surrounding arteries and of ultrasound studies to visualize the blood vessels around which the nerves travel.

- 10 Figure 29E depicts the results of design processes in which the angle, length, and surface area from CT scans is quantified.

Figures 30A-I depicts results of simulations to apply focused ultrasound to the region of a renal artery with a prototype device design based on simulations.

Detailed Description

Hypertension is a disease of extreme national and international importance. There are 80 million patients in the US alone who have
5 hypertension and over 200 million in developed countries worldwide. In the United States, there are 60 million patients who have uncontrolled hypertension, meaning that they are either non-compliant or cannot take the medications because of the side effect profile. Up to 10 million people might have completely resistant hypertension in
10 which they do not reach target levels no matter what the medication regimen. The morbidities associated with uncontrolled hypertension are profound, including stroke, heart attack, kidney failure, peripheral arterial disease, etc. A convenient and straightforward minimally invasive procedure to treat hypertension would be a very
15 welcome advance in the treatment of this disease.

Congestive Heart Failure ("CHF") is a condition which occurs when the heart becomes damaged and blood flow is reduced to the organs of the body. If blood flow decreases sufficiently, kidney function becomes altered, which results in fluid retention, abnormal hormone secretions
20 and increased constriction of blood vessels. These results increase the workload of the heart and further decrease the capacity of the heart to pump blood through the kidneys and circulatory system.

It is believed that progressively decreasing perfusion of the kidneys is a principal non-cardiac cause perpetuating the downward
25 spiral of CHF. For example, as the heart struggles to pump blood, the cardiac output is maintained or decreased and the kidneys conserve fluid and electrolytes to maintain the stroke volume of the heart. The resulting increase in pressure further overloads the cardiac muscle such that the cardiac muscle has to work harder to pump against
30 a higher pressure. The already damaged cardiac muscle is then further stressed and damaged by the increased pressure. Moreover, the fluid overload and associated clinical symptoms resulting from these physiologic changes result in additional hospital admissions, poor

quality of life, and additional costs to the health care system. In addition to exacerbating heart failure, kidney failure can lead to a downward spiral and further worsening kidney function. For example, in the forward flow heart failure described above, (systolic heart failure) the kidney becomes ischemic. In backward heart failure (diastolic heart failure), the kidneys become congested vis-à-vis renal vein hypertension. Therefore, the kidney can contribute to its own worsening failure.

The functions of the kidneys can be summarized under three broad categories: filtering blood and excreting waste products generated by the body's metabolism; regulating salt, water, electrolyte and acid-base balance; and secreting hormones to maintain vital organ blood flow. Without properly functioning kidneys, a patient will suffer water retention, reduced urine flow and an accumulation of waste toxins in the blood and body. These conditions result from reduced renal function or renal failure (kidney failure) and are believed to increase the workload of the heart. In a CHF patient, renal failure will cause the heart to further deteriorate as fluids are retained and blood toxins accumulate due to the poorly functioning kidneys. The resulting hypertension also has dramatic influence on the progression of cerebrovascular disease and stroke.

The autonomic nervous system is a network of nerves which affect almost every organ and physiologic system to a variable degree. Generally, the system is composed of sympathetic and parasympathetic nerves. For example, the sympathetic nerves to the kidney traverse the sympathetic chain along the spine and synapse within the ganglia of the chain or within the celiac ganglia, then proceeding to innervate the kidney via post-ganglionic fibers inside the "renal nerves." Within the renal nerves, which travel along the renal hila (artery and to some extent the vein), are the post-ganglionic sympathetic nerves and the afferent nerves from the kidney. The afferent nerves from the kidney travel within the dorsal root (if they are pain fibers) and into the anterior root if they are sensory fibers,

then into the spinal cord and ultimately to specialized regions of the brain. The afferent nerves, baroreceptors and chemoreceptors, deliver information from the kidneys back to the sympathetic nervous system via the brain; their ablation or inhibition is at least partially
5 responsible for the improvement seen in blood pressure after renal nerve ablation, or denervation, or partial disruption. It has also been suggested and partially proven experimentally that the baroreceptor response at the level of the carotid sinus is mediated by the renal artery afferent nerves such that loss of the renal artery
10 afferent nerve response blunts the response of the carotid baroreceptors to changes in arterial blood pressure (American J. Physiology and Renal Physiology 279:F491-F501, 2000, incorporated by reference herein).

It has been established in animal models that the heart failure
15 condition results in abnormally high sympathetic activation of the kidneys. An increase in renal sympathetic nerve activity leads to decreased removal of water and sodium from the body, as well as increased renin secretion which stimulates aldosterone secretion from the adrenal gland. Increased renin secretion can lead to an increase
20 in angiotensin II levels which leads to vasoconstriction of blood vessels supplying the kidneys as well as systemic vasoconstriction, all of which lead to a decrease in renal blood flow and hypertension. Reduction in sympathetic renal nerve activity, e.g., via de-
innervation, may reverse these processes and in fact has been shown to
25 in the clinic. Similarly, in obese patients, the sympathetic drive is intrinsically very high and is felt to be one of the causes of hypertension in obese patients.

Recent clinical work has shown that de-innervation of the renal
sympathetic chain and other nerves which enter the kidney through the
30 hilum can lead to profound systemic effects in patients (rats, dogs, pig, sheep, humans) with hypertension, heart failure, and other organ system diseases. Such treatment can lead to long term reduction in the need for blood pressure medications and improvements in blood pressure

(O'Brien Lancet 2009 373; 9681 incorporated by reference). The devices used in this trial were highly localized radiofrequency (RF) ablation to ablate the renal artery adventitia with the presumption that the nerves surrounding the renal artery are being inhibited in the heating zone as well. The procedure is performed in essentially a blind fashion in that the exact location of the nerve plexus is not known prior to, during, or after the procedure. In addition, the wall of the renal artery is invariably damaged by the RF probe and patients whose vessels have a great deal of atherosclerosis cannot be treated safely. In addition, depending on the distance of the nerves from the vessel wall, the energy may not consistently lead to ablation or interruption. Finally, the use of internal catheters may not allow for treatment inside the kidney or inside the aorta if more selective. In many cases, it is required to create a spiral along the length and inside the blood vessel to avoid circumferential damage to the vessel.

Cross-sectional imaging can be utilized to visualize the internal anatomy of patients via radiation (CT) or magnetic fields (MRI). Ultrasound can also be utilized to obtain cross-sections of specific regions but only at high frequencies; therefore, ultrasound is typically limited to imaging superficial body regions. CT and MRI are often more amenable to cross sectional imaging because the radiation penetrates well into tissues. In addition, the scale of the body regions is maintained such that the anatomy within the coordinate references remains intact relative to one another; that is, distances between structures can be measured.

With ultrasound, scaling can be more difficult because of unequal penetration as the waves propagate deeper through the tissue. CT scans and MRIs and even ultrasound devices can be utilized to create three dimensional representations and reconstructed cross-sectional images of patients; anatomy can be placed in a coordinate reference frame using a three dimensional representation. Once in the reference frame, energy devices (transducers) can be placed in position and energy emitting devices directed such that specific regions of the

body are targeted. Once knowledge of the transducer position is known relative to the position of the target in the patient body, energy can be delivered to the target.

5 Ultrasound is a cyclically generated sound pressure wave with a
frequency greater than the upper limit of human hearing...20 kilohertz
(kHz). In medicine, ultrasound is widely utilized because of its
ability to penetrate tissues. Reflection of the sound waves reveals a
signature of the underlying tissues and as such, ultrasound can be
used extensively for diagnostics and potentially therapeutics as well
10 in the medical field. As a therapy, ultrasound has the ability to
both penetrate tissues and can be focused to create ablation zones.
Because of its simultaneous ability to image, ultrasound can be
utilized for precise targeting of lesions inside the body. Ultrasound
intensity is measured by the power per cm^2 (for example, W/cm^2 at the
15 therapeutic target region). Generally, high intensity refers to
intensities over $0.1 - 5\text{kW}/\text{cm}^2$. Low intensity ultrasound encompasses
the range up to $0.01 - .10 \text{kW}/\text{cm}^2$ from about 1 or 10 Watts per cm^2 .

Ultrasound can be utilized for its forward propagating waves and
resulting reflected waves or where energy deposition in the tissue and
20 either heating or slight disruption of the tissues is desired. For
example, rather than relying on reflections for imaging, lower
frequency ultrasonic beams (e.g. $< 1\text{MHz}$) can be focused at a depth
within tissue, creating a heating zone or a defined region of
cavitation in which micro-bubbles are created, cell membranes are
25 opened to admit bioactive molecules, or damage is otherwise created in
the tissue. These features of ultrasound generally utilize
frequencies in the 0.25 Megahertz (MHz) to 10 MHz range depending on
the depth required for effect. Focusing is, or may be, required so
that the surface of the tissue is not excessively injured or heated by
30 single beams. In other words, many single beams can be propagated
through the tissue at different angles to decrease the energy
deposition along any single path yet allow the beams to converge at a
focal spot deep within the tissue. In addition, reflected beams from

multiple angles may be utilized in order to create a three dimensional representation of the region to be treated in a coordinate space.

It is important when planning an ultrasound therapy that sharp, discontinuous interfaces be avoided. For example, bowel, lung, bone
5 which contain air and/or bone interfaces constitute sharp boundaries with soft tissues. These interfaces make the planning and therapy more difficult. If however, the interfaces can be avoided, then treatment can be greatly simplified versus what has to done for the brain (e.g. MR-guided HIFU) where complex modeling is required to
10 overcome the very high attenuation of the cranium. Data provided below reveals a discovery through extensive experimentation as to how to achieve this treatment simplicity.

Time of flight measurements with ultrasound can be used to range find, or find distances between objects in tissues. Such measurements can
15 be utilized to place objects such as vessels into three dimensional coordinate reference frames so that energy can be utilized to target the tissues. SONAR is the acronym for sound navigation and ranging and is a method of acoustic localization. Sound waves are transmitted through a medium and the time for the sound to reflect back to the
20 transmitter is indicative of the position of the object of interest. Doppler signals are generated by a moving object. The change in the forward and reflected wave results in a velocity for the object.

The concept of speckle tracking is one in which the reflections of specific tissues is defined and tracked over time (IEEE Transactions
25 on Ultrasonics, Ferroelectrics, AND Frequency Control, Vol. 57, no. 4, April 2010, herein incorporated by reference). With defined points in space, a three dimensional coordinate reference can be created through which energy can be applied to specific and well-defined regions. To track a speckle, an ultrasound image is obtained from a tissue. Light
30 and dark spots are defined in the image, these light and dark spots representing inhomogeneities in the tissues. The inhomegeneities are relatively constant, being essentially properties of the tissue. With

relatively constant markers in the tissue, tracking can be accomplished using real time imaging of the markers. With more than one plane of ultrasound, the markers can be related in three dimensions relative to the ultrasound transducer and a therapeutic energy delivered to a defined position within the three dimensional field.

At the time one or more of these imaging modalities is utilized to determine the position of the target in three dimensions, then a therapy can be both planned and applied to a specific region within the three dimensional volume.

Lithotripsy was introduced in the early part of the 1980's. Lithotripsy utilizes shockwaves to treat stones in the kidney. The Dornier lithotripsy system was the first system produced for this purpose. The lithotripsy system sends ultrasonic waves through the patient's body to the kidney to selectively heat and vibrate the kidney stones; that is, selectively over the adjacent tissue. At the present time, lithotripsy systems do not utilize direct targeting and imaging of the kidney stone region. A tremendous advance in the technology *would* be to image the stone region and target the specific region in which the stone resides so as to minimize damage to surrounding structures such as the kidney. In the case of a kidney stone, the kidney is in fact the speckle, allowing for three dimensional targeting and tracking off its image with subsequent application of ultrasound waves to break up the stone. In the embodiments which follow below, many of the techniques and imaging results described can be applied to clinical lithotripsy.

Histotripsy is a term given to a technique in which tissue is essentially vaporized using cavitation rather than heating (transcutaneous non-thermal mechanical tissue fractionation). These mini explosions do not require high temperature and can occur in less than a second. The generated pressure wave is in the range of megapascals (MPa) and even up to or exceeding 100 MPa. To treat small

regions of tissue very quickly, this technique can be very effective. The border of the viable and non-viable tissue is typically very sharp and the mechanism of action has been shown to be cellular disruption.

5 In one embodiment, ultrasound is focused on the region of the renal arteries and/or veins from outside the patient; the ultrasound is delivered from multiple angles to the target, thereby overcoming many of the deficiencies in previous methods and devices put forward to ablate renal sympathetic nerves which surround the renal arteries.

10 Specifically, one embodiment allows for precise visualization of the ablation zone so that the operator can be confident that the correct region is ablated and that the incorrect region is not ablated. Because some embodiments do not require a puncture in the skin, they are considerably less invasive, which is more palatable and safer from the patient standpoint. Moreover, unusual anatomies and
15 atherosclerotic vessels can be treated using external energy triangulated on the renal arteries to affect the sympathetic and afferent nerves to and from the kidney respectively.

With reference to FIG. 1A, the human renal anatomy includes the kidneys 100 which are supplied with oxygenated blood by the renal
20 arteries 200 and are connected to the heart via the abdominal aorta 300. Deoxygenated blood flows from the kidneys to the heart via the renal veins (not shown) and thence the inferior vena cava (not shown). The renal anatomy includes the cortex, the medulla, and the hilum. Blood is delivered to the cortex where it filters through the
25 glomeruli and is then delivered to the medulla where it is further filtered through a series of reabsorption and filtration steps in the loops of henle and individual nephrons; the ultrafiltrate then percolates to the ureteral collecting system and is delivered to the ureters and bladder for ultimate excretion.

30 The hila is the region where the major vessels (renal artery and renal vein) and nerves 150 (efferent sympathetic, afferent sensory, and parasympathetic nerves) travel to and from the kidneys. The renal

5 nerves 150 contain post-ganglionic efferent nerves which supply sympathetic innervation to the kidneys. Afferent sensory nerves travel from the kidney to the central nervous system and are postganglionic afferent nerves with nerve bodies in the central nervous system. These nerves deliver sensory information to the central nervous system and are thought to regulate much of the sympathetic outflow from the central nervous system to all organs including the skin, heart, kidneys, brain, etc.

10 In one method, energy is delivered from outside a patient, through the skin, and to the renal afferent and/or renal efferent nerves. Microwave, light, vibratory (e.g. acoustic), ionizing radiation might be utilized in some or many of the embodiments.

15 Energy transducers 510 (figure 1A) deliver energy transcutaneously to the region of the sympathetic ganglia 520 or the post-ganglionic renal nerves 150 or the nerves leading to the adrenal gland 400. The energy is generated from outside the patient, from multiple directions, and through the skin to the region of the renal nerves 624 which surround the renal artery 620 or the sympathetic ganglion 622 which house the nerves. The energy can be focused or non-focused but in one preferred embodiment, the energy is focused with high intensity focused ultrasound (HIFU) or low intensity focused ultrasound.

25 Focusing with low intensity focused ultrasound (LIFU) may also occur intentionally as a component of the HIFU (penumbra regions) or unintentionally. The mechanism of nerve inhibition is variable depending on the "low" or "high" of focused ultrasound. Low energy might include energies levels of $25\text{W}/\text{cm}^2$ - $200\text{W}/\text{cm}^2$. Higher intensity includes energy levels from $200\text{ W}/\text{cm}^2$ to $1\text{ MW}/\text{cm}^2$. Focusing occurs by delivering energy from at least two different angles through the skin to meet at a focal point where the highest energy intensity and density occurs. At this spot, a therapy is delivered and the therapy can be sub-threshold nerve interruption (partial ablation), ablation (complete interruption) of the nerves, controlled interruption of the

nerve conduction apparatus, partial ablation, or targeted drug delivery. The region can be heated to a temperature of less than 60 degrees Celsius for non-ablative therapy or can be heated greater than 60 degrees Celsius for heat based destruction (ablation). To ablate the nerves, even temperatures in the 40 degree Celsius range can be used and if generated for a time period greater than several minutes, will result in ablation. For temperatures at about 50 degrees Celsius, the time might be under one minute. Heating aside, a vibratory effect for a much shorter period of time at temperatures below 60 degrees Celsius can result in partial or complete paralysis of destruction of the nerves. If the temperature is increased beyond 50-60 degrees Celsius, the time required for heating is decreased considerably to affect the nerve via the sole mechanism of heating. In some embodiments, an imaging modality is included as well in the system. The imaging modality can be ultrasound based, MRI based, or CT (X-Ray) based. The imaging modality can be utilized to target the region of ablation and determined the distances to the target.

The delivered energy can be ionizing or non-ionizing energy in some embodiments. Forms of non-ionizing energy can include electromagnetic energy such as a magnetic field, light, an electric field, radiofrequency energy, and light based energy. Forms of ionizing energy include x-ray, proton beam, gamma rays, electron beams, and alpha rays. In some embodiments, the energy modalities are combined. For example, heat ablation of the nerves is performed and then ionizing radiation is delivered to the region to prevent re-growth of the nerves.

Alternatively, ionizing radiation is applied first as an ablation modality and then heat applied afterward in the case of re-growth of the tissue as re-radiation may not be possible (complement or multimodality energy utilization). Ionizing radiation may prevent or inhibit the re-growth of the nervous tissue around the vessel if there is indeed re-growth of the nervous tissue. Therefore, another method

of treating the nerves is to first heat the nerves and then apply ionizing radiation to prevent re-growth.

Other techniques such as photodynamic therapy including a photosensitizer and light source to activate the photosensitizer can be utilized as a manner to combine modalities. Most of these
5 photosensitizing agents are also sensitive to ultrasound energy yielding the same photoreactive species as if it were activated by light. A photoreactive or photosensitive agent can be introduced into the target area prior to the apparatus being introduced into the blood
10 vessel; for example, through an intravenous injection, a subcutaneous injection, etc.. However, it will be understood that if desired, the apparatus can optionally include a lumen for delivering a photoreactive agent into the target area. The resulting embodiments are likely to be particularly beneficial where uptake of the
15 photoreactive agent into the target tissues is relatively rapid, so that the apparatus does not need to remain in the blood vessel for an extended period of time while the photoreactive agent is distributed into and absorbed by the target tissue.

Light source arrays can include light sources that provide more than
20 one wavelength or waveband of light. Linear light source arrays are particularly useful to treat elongate portions of tissue. Light source arrays can also include reflective elements to enhance the transmission of light in a preferred direction. For example, devices can beneficially include expandable members such as inflatable
25 balloons to occlude blood flow (which can interfere with the transmission of light from the light source to the intended target tissue) and to enable the apparatus to be centered in a blood vessel. Another preferred embodiment contemplates a transcutaneous PDT method where the photosensitizing agent delivery system comprises a liposome
30 delivery system consisting essentially of the photosensitizing agent.

Yet another embodiment of the present invention is drawn to a method for transcutaneous ultrasonic therapy of a target lesion in a

mammalian subject utilizing a sensitizer agent. In this embodiment, the biochemical compound is activated by ultrasound through the following method:

- 5 1) administering to the subject a therapeutically effective amount of an ultrasonic sensitizing agent or a ultrasonic sensitizing agent delivery system or a prodrug, where the ultrasonic sensitizing agent or ultrasonic sensitizing agent delivery system or prodrug selectively binds to the thick or thin neointimas, nerve cells, nerve sheaths,
10 nerve nuclei, arterial plaques, vascular smooth muscle cells and/or the abnormal extracellular matrix of the site to be treated. Nerve components can also be targeted, for example, the nerve sheath, myelin, S-100 protein. This step is followed by irradiating at least a portion of the subject with ultrasonic energy at a frequency that
15 activates the ultrasonic sensitizing agent or if a prodrug, by a prodrug product thereof, where the ultrasonic energy is provided by an ultrasonic energy emitting source. This embodiment further provides, optionally, that the ultrasonic therapy drug is cleared from non-target tissues of the subject prior to irradiation.
- 20 A preferred embodiment of this invention contemplates a method for transcutaneous ultrasonic therapy of a target tissue, where the target tissue is close to a blood vessel.
- Other preferred embodiments of this invention contemplate that the ultrasonic energy emitting source is external to the patient's intact
25 skin layer or is inserted underneath the patient's intact skin layer, but is external to the blood vessel to be treated. An additional preferred embodiment t of this invention provides that the ultrasonic sensitizing agent is conjugated to a ligand and more preferably, where the ligand is selected from the group consisting of: a target lesion
30 specific antibody; a target lesion specific peptide and a target lesion specific polymer. Other preferred embodiments of the present invention contemplate that the ultrasonic sensitizing agent is selected from the group consisting of: indocyanine green (ICG); methylene blue; toluidine blue; aminolevulinic acid (ALA); chlorin

compounds; phthalocyanines; porphyrins; purpurins; texaphyrins; and any other agent that absorbs light in a range of 500 nm-1100 nm. A preferred embodiment of this invention contemplates that the photosensitizing agent is indocyanine green (ICG).

5

Other embodiments of the present invention are drawn to the presently disclosed methods of transcutaneous PDT, where the light source is positioned in proximity to the target tissue of the subject and is selected from the group consisting of: an LED light source; an
10 electroluminescent light source; an incandescent light source; a cold cathode fluorescent light source; organic polymer light source; and inorganic light source. A preferred embodiment includes the use of an LED light source.

10

Yet other embodiments of the presently disclosed methods are drawn to use of light of a wavelength that is from about 500 nm to about 1100 nm, preferably greater than about 650 nm and more preferably greater than about 700 nm. A preferable embodiment of the present method is drawn to the use of light that results in a single photon absorption
20 mode by the photosensitizing agent.

20

Additional embodiments of the present invention include compositions of photosensitizer targeted delivery system comprising: a photosensitizing agent and a ligand that binds a receptor on the
25 target tissue with specificity. Preferably, the photosensitizing agent of the targeted delivery system is conjugated to the ligand that binds a receptor on the target (nerve or adventitial wall of blood vessel) with specificity. More preferably, the ligand comprises an antibody that binds to a receptor. Most preferably, the receptor is an antigen
30 on thick or thin neointimas, intimas, adventitiaof arteries, arterial plaques, vascular smooth muscle cells and/or the extracellular matrix of the site to be treated.

30

A further preferred embodiment of this invention contemplates that the photosensitizing agent is selected from the group consisting of: indocyanine green (ICG); methylene blue; toluidine blue; aminolevulinic acid (ALA); chlorin compounds; phthalocyanines; porphyrins; purpurins; texaphyrins; and any other agent that absorbs light in a range of 500 nm -1100 nm.

Other photosensitizers of the present invention are known in the art, including, photofrin. RTM, synthetic diporphyrins and dichlorins, phthalocyanines with or without metal substituents, chloroaluminum phthalocyanine with or without varying substituents, chloroaluminum sulfonated phthalocyanine, O-substituted tetraphenyl porphyrins, 3,1-meso tetrakis (o-propionamido phenyl) porphyrin, verdins, purpurins, tin and zinc derivatives of octaethylpurpurin, etiopurpurin, hydrophorphyrins, bacteriochlorins of the tetra(hydroxyphenyl) porphyrin series, chlorins, chlorin e6, mono-l-aspartyl derivative of chlorin e6, di-l-aspartyl derivative of chlorin e6, tin(IV) chlorin e6, meta-tetrahydroxyphenylchlorin, benzoporphyrin derivatives, benzoporphyrin monoacid derivatives, tetracyanoethylene adducts of benzoporphyrin, dimethyl acetylenedicarboxylate adducts of benzoporphyrin, Diels-Adler adducts, monoacid ring "a" derivative of benzoporphyrin, sulfonated aluminum PC, sulfonated AlPc, disulfonated, tetrasulfonated derivative, sulfonated aluminum naphthalocyanines, naphthalocyanines with or without metal substituents and with or without varying substituents, zinc naphthalocyanine, anthracenediones, anthrapyrazoles, aminoanthraquinone, phenoxazine dyes, phenothiazine derivatives, chalcogenapyrylium dyes, cationic seleno and tellurapyrylium derivatives, ring-substituted cationic PC, pheophorbide derivative, pheophorbide alpha and ether or ester derivatives, pyropheophorbides and ether or ester derivatives, naturally occurring porphyrins, hematoporphyrin, hematoporphyrin derivatives, hematoporphyrin esters or ethers, protoporphyrin, ALA-induced protoporphyrin IX, endogenous metabolic precursors, 5-aminolevulinic acid benzonaphthoporphyrazines, cationic imminium

salts, tetracyclines, lutetium texaphyrin, tin-etio-purpurin, porphycenes, benzophenothiazinium, pentaphyrins, texaphyrins and hexaphyrins, 5-amino levulinic acid, hypericin, pseudohypericin, hypocrellin, terthiophenes, azaporphyrins, azachlorins, rose bengal, phloxine B, erythrosine, iodinated or brominated derivatives of fluorescein, merocyanines, nile blue derivatives, pheophytin and chlorophyll derivatives, bacteriochlorin and bacteriochlorophyll derivatives, porphocyanines, benzochlorins and oxobenzochlorins, sapphyrins, oxasapphyrins, cercosporins and related fungal metabolites and combinations thereof.

Several photosensitizers known in the art are FDA approved and commercially available. In a preferred embodiment, the photosensitizer is a benzoporphyrin derivative ("BPD"), such as BPD-MA, also commercially known as BPD Verteporfin or "BPD" (available from QLT). U.S. Patent No. 4,883,790 describes BPD compositions. BPD is a second-generation compound, which lacks the prolonged cutaneous phototoxicity of Photofrin® (Levy (1994) Semin Oncol 21: 4-10). BPD has been thoroughly characterized (Richter et al., (1987) JNCI 79:1327-1331), (Aveline et al. (1994) Photochem Photobiol 59:328-35), and it has been found to be a highly potent photosensitizer for PDT.

In a preferred embodiment, the photosensitizer is tin ethyl etiopurpurin, commercially known as purlytin (available from Miravant).

In some embodiments, external neuromodulation is performed in which low energy ultrasound is applied to the nerve region to modulate the nerves. For example, it has been shown in the past that low intensity (e.g. non-thermal) ultrasound can affect nerves at powers which range from 30-500 mW/Cm² whereas HIFU (thermal modulation), by definition generates heat at a focus, requires power levels exceeding 1000 W/Cm². The actual power flux to the region to be ablated is dependent on the environment including surrounding blood flow and other structures. With low intensity ultrasound, the energy does not have to be so

strictly focused to the target because it's a non-ablative energy; that is, the vibration or mechanical pressure may be the effector energy and the target may have a different threshold for effect depending on the tissue. However, even low energy ultrasound may
5 require focusing if excessive heat to the skin is a worry or if there are other susceptible structures in the path and only a pinpoint region of therapy is desired. Nonetheless, transducers 500 in Figure 1a provide the ability to apply a range of different energy and power levels as well as modeling capability to target different regions and
10 predict the response.

In figure 1a, and in one embodiment, a renal artery 640 is detected with the assistance of imaging devices 600 such as Doppler ultrasound, infrared imaging, thermal imaging, B-mode ultrasound, MRI, or a CT scan. With an image of the region to be treated, measurements
15 in multiple directions on a series of slices can be performed so as to create a three-dimensional representation of the area of interest. By detecting the position of the renal arteries from more than one angle via Doppler triangulation (for example) or another triangulation technique, a three dimensional positional map can be created and the
20 renal artery can be mapped into a coordinate reference frame. In this respect, given that the renal nerves surround the renal blood vessels in the hilum, locating the direction and lengths of the blood vessels in three dimensional coordinate reference is the predominant component of the procedure to target these sympathetic nerves. Within the three
25 dimensional reference frame, a pattern of energy can be applied to the vicinity of the renal artery from a device well outside the vicinity (and outside of the patient altogether) based on knowledge of the coordinate reference frame.

For example, once the renal artery is placed in the coordinate
30 reference frame with the origin of the energy delivery device, an algorithm is utilized to localize the delivery of focused ultrasound to heat or apply mechanical energy to the adventitia and surrounding regions of the artery which contain sympathetic nerves to the kidney

and afferent nerves from the kidney, thereby decreasing the sympathetic stimulus to the kidney and decreasing its afferent signaling back to the autonomic nervous system; affecting these targets will modulate the propensity toward hypertension which would otherwise occur. The ultrasonic energy delivery can be modeled
5 mathematically by predicting the acoustic wave dissipation using the distances and measurements taken with the imaging modalities of the tissues and path lengths.

In one embodiment of an algorithm, the Doppler signal from the artery
10 is identified from at least two different directions and the direction of the artery is reconstructed in three dimensional space. With two points in space, a line is created and with knowledge of the thickness of the vessel, a tube, or cylinder, can be created to represent the blood vessel as a virtual model. The tube is represented in three
15 dimensional space over time and its coordinates are known relative to the therapeutic transducers outside of the skin of the patient. Therapeutic energy can be applied from more than one direction as well and can focus on the cylinder (blood anterior vessel wall, central axis, or posterior wall).

20 Focused energy (e.g. ultrasound) can be applied to the center of the vessel (within the flow), on the posterior wall of the vessel, in between (e.g. when there is a back to back artery and vein next to one another) the artery vessel and a venous vessel, etc.

Imaging 600 of the sympathetic nerves or the sympathetic region (the
25 target) is also utilized so as to assess the direction and orientation of the transducers relative to the target 620; the target is an internal fiducial, which in one embodiment is the kidney 610 and associated renal artery 620 because they can be localized via their blood flow, a model then produced around it, and then they both can be
30 used as a target for the energy. Continuous feedback of the position of the transducers 500, 510 relative to the target 620 is provided by the imaging system in which the coordinate space of the imaging

system. The imaging may be a cross-sectional imaging technology such as CT or MRI or it may be an ultrasound imaging technology which yields faster real time imaging. In some embodiments, the imaging may be a combination of technologies such as the fusion of MRI/CT and
5 ultrasound. The imaging system can detect the position of the target in real time at frequencies ranging from 1 Hz to thousands and tens of thousands of images per second.

In the example of fusion, cross-sectional imaging (e.g. MRI/CT) is utilized to place the body of the patient in a three dimensional
10 coordinate frame and then ultrasound is linked to the three dimensional reference frame and utilized to track the patient's body in real time under the ultrasound linked to the cross-sectional imaging. The lack of resolution provided by the ultrasound is made up for by the cross-sectional imaging since only a few consistent
15 anatomic landmarks are required for an ultrasound image to be linked to the MRI image. As the body moves under the ultrasound, the progressively new ultrasound images are linked to the MRI images and therefore MRI "movement" can be seen at a frequency not otherwise available to an MRI series.

20 In one embodiment, ultrasound is the energy used to inhibit nerve conduction in the sympathetic nerves. In one embodiment, focused ultrasound (HIFU) from outside the body through the skin is the energy used to inhibit sympathetic stimulation of the kidney by delivering waves from a position external to the body of a patient and focusing
25 the waves on the sympathetic nerves on the inside of the patient and which surround the renal artery of the patient.

As is depicted in Figure 3a-b, transducers 900 can emit ultrasound energy from a position outside the patient to the region of the renal sympathetic nerves at the renal pedicle 200. As shown in figure 1a,
30 an image of the renal artery 620 using an ultrasound, MRI, or CT scan can be utilized to determine the position of the kidney 610 and the renal artery 620 target. Doppler ultrasound can be used to determine

the location and direction of a Doppler signal from an artery and place the vessel into a three dimensional reference frame 950, thereby enabling the arteries 200 and hence the sympathetic nerves 220 (Figure 3a) around the artery to be much more visible so as to process the
5 images and then utilize focused external energy to pinpoint the location and therapy of the sympathetic nerves. In this embodiment, ultrasound is likely the most appropriate imaging modality.

Figure 1a also depicts the delivery of focused energy to the sympathetic nerve trunks and ganglia 622 which run along the vertebral
10 column and aorta 300; the renal artery efferent nerves travel in these trunks and synapse to ganglia within the trunks. In another embodiment, ablation of the dorsal and ventral roots at the level of the ganglia or dorsal root nerves at T9-T11 (through which the afferent renal nerves travel) would produce the same or similar effect
15 to ablation at the level of the renal arteries.

In another embodiment, figure 1b illustrates the application of ionizing energy to the region of the sympathetic nerves on the renal arteries 620 and/or renal veins. In general, energy levels of greater than 20 Gy (Gray) are required for linear accelerators or low energy
20 x-ray machines to ablate nervous tissue using ionizing energy; however, lower energy is required to stun, inhibit nervous tissue, or prevent re-growth of nervous tissue; in some embodiment, ionizing energy levels as low as 2-5 Gy or 5-10 Gy or 10-15 Gy are delivered in a single or fractionated doses.

25 Combinations of ionizing energy and other forms of energy can be utilized in this embodiment as well so as to prevent re-growth of the nervous tissue. For example, a combination of heat and/or vibration and/or cavitation and/or ionizing radiation might be utilized to prevent re-growth of nervous tissue after the partial or full ablation
30 of the nervous tissue surrounding the renal artery.

Figure 2 illustrates the renal anatomy and surrounding anatomy with greater detail in that organs such as the stomach 700 are shown in its

anatomic position overlying the abdominal aorta 705 and renal arteries 715. In this embodiment, energy is delivered through the stomach to reach an area behind the stomach. In this embodiment, the stomach is utilized as a conduit to access the celiac ganglion 710, a region
5 which would otherwise be difficult to reach. The aorta 705 is shown underneath the stomach and the celiac ganglion 710 is depicted surrounding the superior mesenteric artery and aorta. A transorally placed tube 720 is placed through the esophagus and into the stomach. The tube overlies the celiac ganglion when placed in the stomach and
10 can therefore be used to deliver sympatholytic devices or pharmaceuticals which inhibit or stimulate the autonomic celiac ganglia behind the stomach; these therapies would be delivered via transabdominal ultrasound or fluoroscopic guidance (for imaging) through the stomach. Similar therapies can be delivered to the
15 inferior mesenteric ganglion, renal nerves, or sympathetic nerves traveling along the aorta through the stomach or other portion of the gastrointestinal tract. The energy delivery transducers 730,731 are depicted external to the patient and can be utilized to augment the therapy being delivered through the stomach to the celiac ganglion.
20 Alternatively, the energy delivery transducers can be utilized for imaging the region of therapy.

In one embodiment, energy is applied to the region of the celiac ganglion from a region outside the patient. In this embodiment, fluid is placed into the gastrointestinal system, such as for example, in
25 the stomach or small intestine. Ultrasound can then be transmitted through the gastrointestinal organs to the ganglia of interest behind the stomach.

Temporary neurostimulators can also be placed through the tube, such as, for example, in an ICU setting where temporary blockage of the
30 autonomic ganglia may be required. Temporary neurostimulators can be used to over pace the celiac ganglion nerve fibers and inhibit their function as a nerve synapse. Inhibition of the celiac ganglion may achieve a similar function as ablation or modulation of the

sympathetic nerves around the renal arteries. That is, the decrease in the sympathetic activity to the kidneys (now obtained with a more proximal inhibition) leads to the lowering of blood pressure in the patient by decreasing the degree of sympathetic outflow from the sympathetic nerve terminals. In the celiac ganglia, the blood pressure lowering effect is more profound given that the celiac ganglia are pre-ganglionic and have more nerve fibers to a greater number of regions than each renal nerve. The effect is also likely more permanent than the effect on the post-ganglionic nerve fibers.

10 Fig. 3a illustrates the renal anatomy more specifically in that the renal nerves 220 extending longitudinally along the renal artery 200, are located generally within, or just outside the adventitia, of the outer portion of the artery. Arteries are typically composed of three layers: the first is the intimal, the second is the media, and the
15 third is the adventitia. The outer layer, the adventitia, is a fibrous tissue which contains blood vessels and nerves. The renal nerves are generally postganglionic sympathetic nerves although there are some ganglia which exist distal to the takeoff from the aorta such that some of the nerve fibers along the renal artery are in fact pre-
20 ganglionic. By the time the fibers reach the kidney, the majority of the fibers are post-ganglionic. The afferent nerves on the other hand leave the kidney and are post-ganglionic up to the level of the brain. These fibers do not re-grow as quickly as the efferent fibers, if at all.

25 Energy generators 900 deliver energy to the renal nerves accompanying the renal artery, depositing energy from multiple directions to target inhibition of the renal nerve complex. The energy generators can deliver ultrasound energy, ionizing radiation, light (photon) therapy, or microwave energy to the region. The energy can be non-focused in
30 the case where a pharmaceutical agent is targeted to the region to be ablated or modulated. Preferably, however, the energy is focused, being applied from multiple angles from outside the body of the patient to reach the region of interest (e.g. sympathetic nerves

surrounding blood vessels). The energy transducers 900 are placed in an X-Y-Z coordinate reference frame 950, as are the organs such as the kidneys. The x-y-z coordinate frame is a real space coordinate frame. For example, real space means that the coordinate reference is
5 identifiable in the physical world; like a GPS (global positioning system), with the physical coordinates, a physical object can be located. Once in the x-y-z coordinate reference frame, cross-sectional imaging using MRI, CT scan, and/or ultrasound is utilized to couple the internal anatomy to the energy transducers. These same
10 transducers may be utilized for the determination of the reference point as well as the therapy. The transducers 900 in this embodiment are focused on the region of the renal nerves at the level of the renal blood vessels, the arteries and veins 200. The focus of the beams can be inside the artery, inside the vein, on the adventitia of
15 the artery or adventitia of the vein.

When applying ultrasonic energy across the skin to the renal artery region, energy densities of potentially over 1 MW/cm² might be required at region of interest in the adventitia of the blood vessel. Typically, however, power densities of 100 W/cm² to 3 kW/cm² would be
20 expected to create the heating required to inhibit these nerves (see Foley et. al. Image-Guided HIFU Neurolysis of Peripheral Nerves To Treat Spasticity And Pain; Ultrasound in Med & Biol. Vol 30 (9) p 1199-1207 herein incorporated by reference). The energy may be pulsed across the skin in an unfocused manner; however, for application of
25 heat, the transducers must be focused otherwise the skin and underlying tissues will receive too much heat. Under imaging with MRI, temperature can be measured with the MRI image. When low energy ultrasound is applied to the region, energy (power) densities in the range of 50 mW/cm² to 500 mW/cm² may be applied. Low energy ultrasound
30 may be enough to stun or partially inhibit the renal nerves particularly when pulsed and depending on the desired clinical result. High intensity ultrasound applied to the region with only a few degrees of temperature rise may have the same effect and this energy

range may be in the 0.1 kW/cm² to the 500 kW/cm² range. A train of pulses also might be utilized to augment the effect on nervous tissue. For example, a train of 100 short pulses, each less than a second and applying energy densities of 1W/cm² to 500 W/cm². In some of the
5 embodiments, cooling may be applied to the skin if the temperature rise is deemed too large to be acceptable. Alternatively, the ultrasound transducers can be pulsed or can be alternated with another set of transducers to effectively spread the heat across the surface of the skin. In some embodiments, the energy is delivered in a pulsed
10 fashion to further decrease the risk to the intervening tissues between the target and the transducer. The pulses can be as close as millisecond, as described, or as long as hours, days or years.

In one method of altering the physiologic process of renal sympathetic excitation, the region around the renal arteries is imaged
15 using CT scan, MRI, thermography, infrared imaging, optical coherence tomography (OCT), photoacoustic imaging, pet imaging, SPECT imaging, or ultrasound, and the images are placed into a three dimensional coordinate reference frame 950. The coordinate reference frame 950 refers to the knowledge of the relationship between anatomic
20 structures, both two dimensional and three dimensional, the structures placed into a physical coordinate reference. Imaging devices determine the coordinate frame. Once the coordinate frame is established, the imaging and therapy transducers 900 can be coupled such that the information from the imaging system is utilized by the
25 therapeutic transducers to position the energy. Blood vessels may provide a useful reference frame for deposition of energy as they have a unique imaging signature. An ultrasound pulse echo can provide a Doppler shift signature to identify the blood vessel from the surrounding tissue. In an MRI, CT scan, and even an ultrasound exam,
30 intravenous contrast agents can be utilized to identify flow patterns useful to determine a coordinate reference for energy deposition. Energy transducers 900 which can deliver ultrasound, light, radiation, ionizing radiation, or microwave energy are placed in the same three-

dimensional reference frame as the renal arteries, at which time a processor (e.g. using an algorithm) can determine how to direct the transducers to deliver energy to the region 220 of the nerves 910. The algorithm consists of a targeting feature (planning feature) which
5 allows for prediction of the position and energy deposition of the energy leaving the transducers 900.

Once the three dimensional coordinate reference frames 950 are linked or coupled, the planning and prediction algorithm can be used to precisely position the energy beams at a target in the body.

10 The original imaging modality can be utilized to locate the renal sympathetic region can be used to track the motion of the region during treatment. For example, the imaging technology used at time zero is taken as the baseline scan and subsequent scans at time t1 are compared to the baseline scan, t0. The frequency of updates can range
15 from a single scan every few seconds to many scans per second. With ultrasound as the imaging technology, the location might be updated at a frame rate greater than 50 Hz and up to several hundred Hz or thousand Hz. With MRI as the imaging modality, the imaging refresh rate might be closer to 30 Hz. In other embodiments, internally
20 placed fiducials transmit positional information at a high frequency and this information is utilized to fuse the target with an initial external imaging apparatus. Internal fiducials might include one or more imageable elements including doppler signals, regions of blood vessels, ribs, kidneys, and blood vessels and organs other than the
25 target (e.g. vena cava, adrenal gland, ureter). These fiducials can be used to track the region being treated and/or to triangulate to the region to be treated.

In some embodiments (figure 3C), a temporary fiducial 960 is placed in the region, such as in the artery 965, renal vein 975, aorta 945,
30 and/or vena cava 985; such a fiducial is easily imageable from outside the patient.

Figure 3D depicts an imageable transducer 960 in a blood vessel 967 within a coordinate reference 975 on a monitor system 950.

Alternatively, the temporary fiducial 960 is a transducer which further improves the ability to image and track the region to deliver
5 therapy. The temporary fiducial might be a mechanical, optical, electromechanical, a radiofrequency radiotransmitter, global positioning tracking (GPS) device, or ultrasound responsive technology. Similar devices might be found in patent nos. 6,656,131 and 7,470,241 which are incorporated by reference herein.

10 Internal reflections (e.g. speckles) can be tracked as well. These speckles are inherent characteristics of tissue as imaged with ultrasound. They can be tracked and incorporated into treatment planning algorithm and then linked to the therapeutic transducers.

In some embodiments, a test dose of energy can be applied to the renal
15 sympathetic region and then a test performed to determine if an effect was created. For example, a small amount of heat or vibratory energy can be delivered to the region of the sympathetic nerves and then a test of sympathetic activity such as microneurography (detection of sympathetic nerve activity around muscles and nerves which correlate
20 with the beating heart) can be performed. Past research and current clinical data have shown that the sympathetic nerves to the peripheral muscles are affected by interruption of the renal afferent nerves. The degree of temperature rise with the small degree of heat can be determined through the use of MRI thermometry or an ultrasound
25 technique and the temperature rise can be determined or limited to an amount which is reversible.

In another embodiment, a stimulus is applied to a region such as the skin and an output downstream from the skin is detected. For example,
30 a vibratory energy might be applied to the skin and a sympathetic outflow such as the heart rate might be detected. In another embodiment, heat or cold might be applied to the skin and heart rate, blood pressure; vasoconstriction might be detected as an output.

Alternatively, ultrasonic imaging can be utilized to determine the approximate temperature rise of the tissue region. The speed of ultrasonic waves is dependent on temperature and therefore the relative speed of the ultrasound transmission from a region being heated will depend on the temperature, therefore providing measurable variables to monitor. In some embodiments, microbubbles are utilized to determine the rise in temperature. Microbubbles expand and then degrade when exposed to increasing temperature so that they can then predict the temperature of the region being heated. A technique called ultrasound elastography can also be utilized. In this embodiment, the elastic properties of tissue are dependent on temperature and therefore the elastography may be utilized to track features of temperature change. The microbubbles can also be utilized to augment the therapeutic effect of the region being targeted. For example, the microbubbles can be utilized to release a pharmaceutical when the ultrasound reaches them. Alternatively, the microbubble structure can be utilized to enhance imaging of the treatment region to improve targeting or tracking of the treatment region.

In some embodiments, only the temperature determination is utilized. That is, the temperature sensing embodiments and algorithms are utilized with any procedure in which heating is being performed. For example, in a case where heating of the renal nerve region is performed using radiofrequency ablation through the renal artery, imaging of the region from a position external to the patient can be performed while the renal artery region is being heated via radiofrequency methods. Imaging can be accomplished utilizing MRI, ultrasound, infrared, or OCT methods.

In another embodiment, a test may be performed on the baroreceptor complex at the region of the carotid artery bifurcation. After the test dose of energy is applied to the renal artery complex, pressure can be applied to the carotid artery complex; typically, with an intact baroreceptor complex, the systemic blood pressure would decrease after application of pressure to the carotid artery.

However, with renal afferent nerves which have been inhibited, the baroreceptors will not be sensitive to changes in blood pressure and therefore the efficacy of the application of the energy to the renal nerves can be determined. Other tests include attaining indices of
5 autonomic function such as microneurography, autonomic function variability, etc.

In another embodiment, stimulation of the baroreceptor complex is accomplished *non-invasively* via ultrasound pulses applied externally to the region of the carotid body. The ultrasound pulses are
10 sufficient to stimulate the sinus to affect a blood pressure change, a change which will be affected when an afferent nerve such as the renal afferents have been altered.

More specifically, this methodology is depicted in Figure 3E. An ultrasound pulse 980 is utilized to stimulate the carotid sinus which
15 will lower blood pressure transiently 982 by activating the baroreceptor complex; activation of the carotid sinus 980 simulates the effect of an increase in blood pressure which leads to a compensatory outflow of parasympathetic activity and decreased sympathetic outflow, subsequently lowering blood pressure. In the
20 instance when the afferent system (e.g. from the kidney) has been inhibited, the pressure will not be modifiable as quickly if at all. In this case, stimulating the baroreceptor complex does not result in a lowering of blood pressure 986, then the treatment was successful. This diagnostic technique can therefore be utilized to determine the
25 effect of a therapy on a system such as the renal nerve complex. If therapy is successful, then the modifying effect of the ultrasound pulse on the carotid sinus and blood pressure is less dramatic and the therapeutic (treatment of afferent nerves) successful; therefore, therapy can be discontinued 988 temporarily or permanently. If the
30 blood pressure continues to decrease 982 with the baroreceptor stimulation, then the therapeutic effect has not been reached with the therapeutic treatment and it needs to be continued 984 and/or the dose increased. Other methods to stimulate the baroreceptor complex are to

apply pressure in the vicinity with hands, compression balloons, and the like.

Other regions of the autonomic nervous system can also be affected directly by the technology described herein by applying energy from one region and transmitted through tissue to another region. For example, figure 4a illustrates a system in which energy external to the internal carotid artery 1020 is applied to a portion of the autonomic nervous system, the carotid body complex 1000, through the internal jugular vein 1005, and to the carotid body 1000 and/or vagus nerve 1020 region. Ablative energy, vibratory, or electrical stimulation energy can be utilized to affect the transmission of signals to and from these nerves. The transmission in this complex can be augmented, interrupted, inhibited with over-stimulation, or a combination of these effects via energy (e.g. ultrasound, electrical stimulation, etc.).

In addition, or in place of, in other embodiments, energy may be applied to peripheral nerves typically known as motor nerves but which contain autonomic fibers. Such nerves include the saphenous nerve, femoral nerves, lumbar nerves, median nerves, ulnar nerves, and radial nerves. In some embodiments, energy is applied to the nerves and specific autonomic fibers are affected rather than the other neural fibers (e.g. motor or somatic sensory fibers or efferent or afferent autonomic nerves). In some embodiments, other types of autonomic fibers are affected with energy applied internally or externally. For example, nerves surrounding the superior mesenteric artery, the inferior mesenteric artery, the femoral artery, the pelvic arteries, etc. can be affected by the energy in a specific manner so as to create changes in the autonomic responses of the blood vessels themselves or organs related to the blood vessels, the nerves running through and along the vessels to the organs.

In another embodiment, in Figure 4a, a catheter 1010 is advanced into the internal jugular vein 1005 and when in position, stimulation or

ablative energy 1020 is directed toward the autonomic nerves, e.g. the vagus nerve and the carotid sinus/body 1000, from the catheter positioned in the venous system 1005.

In a similar type of embodiment 1100, a catheter based therapeutic
5 energy source 1110 can be inserted into the region of the renal arteries or renal veins (Figure 4B) to stimulate or inhibit the renal nerves from the inside of the vessel, either the renal artery 1105 or renal vein 1106. Energy is transferred through the vessel (e.g. renal vein) to reach the nerves around another vessel (e.g. renal artery).
10 For example, a catheter delivering unfocused ultrasound energy with powers in the range of 50 mW/cm² to 50 kW/cm² can be placed into the renal artery and the energy transmitted radially around the artery or vein to the surrounding nerves. As discussed below, the 500mW - 2500 W/cm² is appropriate to create the specific nerve dysfunction to affect
15 the norepinephrine levels in the kidney, a surrogate of nerve function which has been shown to lead to decreases in blood pressure over time. Pulsed ultrasound, for example, 100 pulse trains with each lasting less than 1 second each, can be applied to the region.

In another embodiment, light is applied through the vessel from within
20 the blood vessel. Infrared, red, blue, and near infrared can all be utilized to affect the function of nerves surrounding blood vessels. For example, a light source is introduced into the renal artery or renal vein 1105, 1106 and the light transmitted to the region surrounding the blood vessels. In a preferred embodiment, a
25 photosensitizing agent is utilized to hasten the inhibition or destruction of the nerve bundles with this technique. Photosensitizing agents can be applied systemically to infiltrate the region around the blood vessels. Light is then applied from inside the vessel to the region of the nerves outside the vessel. For example, the light
30 source is placed inside the renal vein and then light is transmitted through the vein wall to the adventitial region around the wall activating the photosensitizer and injuring or inhibiting the nerves

in the adventitia through an apoptosis pathway. The light source may provide light that is visible, or light that is non-visible.

The therapies in Figs 4a-b can be delivered on an acute basis such as for example in an ICU or critical care setting. In such a case, the therapy would be acute and intermittent, with the source outside the patient and the catheter within the patient as shown in Figures 4a-b. The therapy can be utilized during times of stress for the patient such that the sympathetic system is slowed down. After the intensive care admission is nearing a close, the catheter and unit can be removed from the patient. In one embodiment, a method is described in which a catheter is placed within a patient to deliver energy to a region of the body sufficient to partially or fully inhibit an autonomic nerve complex during a state of profound sympathetic activation such as shock, sepsis, myocardial infarction, pancreatitis, post-surgical. After the acute phase of implantation during which the sympathetic system is modulated, the device is removed entirely.

Figs. 5a-b illustrates the eye in close up detail with sympathetic nerves surrounding the posterior of the eye. In the eye, glaucoma is a problem of world-wide importance. The most commonly prescribed medication to treat glaucoma is timoptic, which is a non-selective $\beta 1$ and $\beta 2$ (adrenergic) antagonist. Compliance with this pharmaceutical is a major problem and limits its effectiveness in preventing the complications of glaucoma, the major complication being progression of visual dysfunction.

Ultrasound, or other energy transducers 7000, can be applied to focus energy from an external region (e.g. a distance from the eye in an external location) anterior to the eye or to a region posteriorly behind the eye on the sympathetic or parasympathetic ganglia, all of which will affect lowering of intra-ocular pressure. The energy transducers 7000 apply ablative or near ablative energy to the adventitia of the blood vessels. In some embodiments, the energy is not ablative but vibratory at frequencies (e.g. 1-5 Mhz) and

penetration depths (e.g. 0.5 mm to 0.5 cm) sufficient to inhibit the function of the nerves which are responsible for intra-ocular pressure. Lower energy (e.g. sub-ablative) can be applied to the eye to assist in drug delivery or to stimulate tissue healing type of
5 tissue responses.

Figure 5b depicts the anatomy of the nerves which travel behind the eye 2500. In this illustration, a catheter 2000 is tunneled through the vasculature to the region of the sympathetic nerves surrounding the arteries of the eye 2010 and utilized to ablate, stun, or
10 otherwise modulate the efferent and/or afferent nerves through the wall of the vasculature.

Figure 6 illustrates an overall schematic of the renal artery, renal vein, the collecting system, and the more distal vessels and collecting system within the renal parenchyma. The individual nerves
15 of the autonomic nervous system typically follow the body vasculature and they are shown in close proximity 3000 to the renal artery as the artery enters the kidney 3100 proper. The hilum of the kidney contains pressure sensors and chemical sensors which influence the inputs to the efferent sympathetic system via afferent nerves traveling from the
20 kidney to the central nervous system and then to the efferent nervous system. Any one or multiple of these structures can influence the function of the kidney. Ablative or non-ablative energy can be applied to the renal vein, the renal artery, the aorta, and/or the vena cava, the renal hilum, the renal parenchyma, the renal medulla,
25 the renal cortex, etc.

In another embodiment, selective lesions, constrictions or implants
3200 are placed in the calyces of the kidney to control or impede blood flow to specific regions of the kidney. Such lesions or implants can be placed on the arterial 3010 or venous sides 3220 of
30 the kidney. In some embodiments, the lesions/implants are created so as to selectively block certain portions of the sympathetic nerves within the kidney. The lesions also may be positioned so as to ablate

regions of the kidney which produce hormones, such as renin, which can be detrimental to a patient in excess. The implants or constrictions can be placed in the aorta 3210 or the renal vein 3230. The implants can be active implants, generating stimulating energy chronically or
5 multiple ablative or inhibitory doses discretely over time.

In the renal vein 3230, the implants 3220, 3200 might cause an increase in the pressure within the kidney (by allowing blood flow to back up into the kidney and increase the pressure) which will prevent the downward spiral of systolic heart failure described above because
10 the kidney will act as if it is experiencing a high pressure head. That is, once the pressure in the kidney is restored or artificially elevated by increased venous pressure, the relative renal hypotension signaling to retain electrolytes and water will not be present any longer and the kidney will "feel" full and the renal sympathetic
15 stimulation will be turned off. In one embodiment, a stent which creates a stenosis is implanted using a catheter delivery system. In another embodiment, a stricture 3220 is created using heat delivered either externally or internally. Externally delivered heat is delivered via direct heating via a percutaneous procedure (through the
20 skin to the region of the kidney) or transmitted through the skin (e.g. with HIFU focused through the skin). In one embodiment, an implant is placed between girota's fascia and the cortex of the kidney. The implant can stimulate or inhibit nerves surrounding the renal blood vessels, or even release pharmaceuticals in a drug
25 delivery system.

Figure 7a depicts at least partial ablation of the renal sympathetic nerves 4400 to the kidney using an imaging system such as an MRI machine or CT scanner 4000. The MRI/CT scan can be linked to a focused ultrasound (HIFU) machine to perform the ablations of the
30 sympathetic nerves 4400 around the region of the renal artery 4500. The MRI/CT scan performs the imaging 4010 and transmits data (e.g. three dimensional representations of the regions of interest) to the ultrasound controller which then directs the ultrasound to target the

region of interest with low intensity ultrasound (50-1000mW/cm²), heat (>1000 mW/cm²), cavitation, or a combination of these modalities and/or including introduction of enhancing bioactive agent delivery locally or systemically (sonodynamic therapy). Optionally, a doppler
5 ultrasound or other 3D/4D ultrasound is performed and the data pushed to the MRI system to assist with localization of the pathology; alternatively, the ultrasound data are utilized to directly control the direction of the energy being used to target the physiologic processes and CT/MRI is not obtained. Using this imaging and ablation
10 system from a position external to a patient, many regions of the kidney can be treated such as the internal calyces 4350, the cortex 4300, the medulla 4320, the hilum 4330, and the region 4340 close to the aorta.

Further parameters which can be measured include temperature via
15 thermal spectroscopy using MRI or ultrasound thermometry/elastography; thermal imaging is a well-known feature of MRI scanners; the data for thermal spectroscopy exists within the MRI scan and can be extrapolated from the recorded data in real time by comparing regions of interest before and after or during treatment. Temperature data
20 overlaid on the MRI scan enables the operator of the machine to visualize the increase in temperature and therefore the location of the heating to insure that the correct region has indeed been ablated and that excessive energy is not applied to the region. Having temperature data also enables control of the ablation field as far as
25 applying the correct temperature for ablation to the nerves. For example, the temperature over time can be determined and fed back to the operator or in an automated system, to the energy delivery device itself. Furthermore, other spectroscopic parameters can be determined using the MRI scan such as oxygenation, blood flow, or other
30 physiologic and functional parameters. In one embodiment, an alternating magnetic field is used to stimulate and then over-stimulate or inhibit an autonomic nerve (e.g. to or from the kidney).

Elastography is a technique in which the shear waves of the ultrasound beam and reflectance are detected. The tissue characteristics change as the tissue is heated and the tissue properties change. An approximate temperature can be assigned to the tissue based on
5 elastography and the progress of the heating can be monitored.

MRI scanners 4000 generally consist of a magnet and an RF coil. The magnet might be an electromagnet or a permanent magnet. The coil is typically a copper coil which generates a radiofrequency field. Recently, permanent magnets have been utilized to create MRI scanners
10 which are able to be used in almost any setting, for example a private office setting. Office based MRI scanners enable imaging to be performed quickly in the convenience of a physician's office as well as requiring less magnetic force (less than 0.5 Tesla) and as a consequence, less shielding. The lower tesla magnets also provides
15 for special advantages as far as diversity of imaging and resolution of certain features. Importantly, the permanent magnet MRI scanners are open scanners and do not encapsulate the patient during the scan.

In one embodiment, a permanent magnet MRI is utilized to obtain an MRI image of the region of interest 4010. High intensity focused 4100
20 ultrasound is used to target the region of interest 4600 identified using the MRI. In one embodiment, the MRI is utilized to detect blood flow within one or more blood vessels such as the renal arteries, renal veins, superior mesenteric artery, veins, carotid arteries and veins, aortic arch coronary arteries, veins, to name a subset.

25 Image 4010 is or can be monitored by a health care professional to ensure that the region of interest is being treated and the treatment can be stopped if the assumed region is not being treated.

Alternatively, an imaging algorithm can be initiated in which the region of interest is automatically (e.g. through image processing)
30 identified and then subsequent images are compared to the initial demarcated region of interest.

Perhaps, most importantly, with MRI, the region around the renal arteries can be easily imaged as can any other region such as the eye, brain, prostate, breast, liver, colon, spleen, aorta, hip, knee, spine, venous tree, and pancreas. The imaging from the MRI can be
5 utilized to precisely focus the ultrasound beam to the region of interest around the renal arteries or elsewhere in the body. With MRI, the actual nerves to be modified or modulated can be directly visualized and targeted with the energy delivered through the body from the ultrasound transducers. One disadvantage of MRI can be the
10 frame acquisition (difficulty in tracking the target) rate as well as the cost of introducing an MRI machine into the treatment paradigm. In these regards, ultrasound imaging offers a much more practical solution.

Figure 7d depicts a method of treating a region with high intensity
15 focused ultrasound (HIFU). Imaging with an MRI 4520 or ultrasound 4510 (or preferably both) is performed. MRI can be used to directly or indirectly (e.g. using functional MRI or spectroscopy) to visualize the sympathetic nerves. T1 weighted or T2 weighted images can be obtained using the MRI scanner. In addition to anatomic imaging, the
20 MRI scanner can also obtain temperature data regarding the effectiveness of the ablation zone as well as the degree to which the zone is being heated and which parts of the zones are being heated. Other spectroscopic parameters can be added as well such as blood flow and even nerve activity. Ultrasound 4510 can be used to add blood
25 flow to the images using Doppler imaging. The spectroscopic data can be augmented by imaging moieties such as particles, imaging agents, or particles coupled to imaging agents which are injected into the patient intravenously, or locally, and proximal to the region of the renal arteries; these imaging moieties may be visualized on MRI,
30 ultrasound, or CT scan. Ultrasound can also be utilized to determine information regarding heating. The reflectance of the ultrasonic waves changes as the temperature of the tissue changes. By comparing the initial images with the subsequent images after heating, the

temperature change which occurred after the institution of heating can be determined.

In one embodiment, the kidneys are detected by a cross-sectional imaging modality such as MRI, ultrasound, or CT scan. The renal
5 arteries and veins are detected within the MRI image utilizing contrast or not utilizing contrast. Next, the imaging data is placed into a three dimensional coordinate system which is linked to one or more ultrasound (e.g. HIFU) transducers 4540 which focus ultrasound onto the region of the renal arteries in the coordinate frame 4530.
10 The linking, or coupling, of the imaging to the therapeutic transducers is accomplished by determining the 3 dimensional position of the target by creating an anatomic model. The transducers are placed in a relative three dimensional coordinate frame as well. For example, the transducers can be placed in the imaging field 4520
15 during the MRI or CT scan such that the cross-sectional pictures include the transducers. Optionally, the transducers contain motion sensors, such as electromagnetic, optical, inertial, MEMS, and accelerometers, one or more of which allow for the transducer position to be monitored if for example the body moves relative to the
20 transducer or the operator moves relative to the body. With the motion sensors, the position of the transducers can be determined with movement which might occur during the therapy. The updated information can then be fed back to the ultrasound therapy device so as to readjust the position of the therapy.

25 In one embodiment, a system is described in which the blood flow in the renal artery is detected by detecting the walls of the artery or renal vein or the blood flow in the renal artery or the renal vein. The coordinate reference of the blood vessels is then transmitted to the therapeutic transducer, for example, ultrasound. The therapeutic
30 transducer is directed to the renal blood vessels using the information obtained by imaging. A model of the vessels indicates the blood flow of the vessels and the walls of the vessels where the

nerves reside. Energy is then applied to the model of the vessels to treat the nerves around the vessels.

Alternatively, in another embodiment, ultrasound is utilized and the ultrasound image 4510 can be directly correlated to the origin of the imaging transducer. The therapeutic transducer 4540 in some
5 embodiments is the same as the imaging transducer and therefore the therapeutic transducer is by definition coupled in a coordinate reference 4540 once the imaging transducer coordinates are known. If the therapeutic transducer and the imaging transducer are different
10 devices, then they can be coupled by knowledge of the relative position of the two devices. The region of interest (ROI) is highlighted in a software algorithm; for example, the renal arteries, the calyces, the medullary region, the cortex, the renal hila, the celiac ganglia, the aorta, or any of the veins of the venous system as
15 well. In another embodiment, the adrenal gland, the vessels traveling to the adrenal gland, or the autonomic nerves traveling to the adrenal gland are targeted with focused ultrasound and then either the medulla or the cortex of the adrenal gland or the nerves and arteries leading to the gland are partially or fully ablated with ultrasonic energy.

20 The targeting region or focus of the ultrasound is the point of maximal intensity. In some embodiments, targeting focus is placed in the center of the artery such that the walls on either side receive equivalent amounts of energy or power and can be heated more evenly than if one wall of the blood vessel is targeted. In some embodiments
25 in which a blood vessel is targeted, the blood vessel being an artery and the artery having a closely surrounding vein (e.g. the renal artery/vein pedicle), the center of the focus might be placed at the boundary of the vein and the artery.

Once the transducers are energized 4550 after the region is targeted, the tissue is heated 4560 and a technique such as MRI thermography
30 4570 or ultrasound thermography is utilized to determine the tissue temperature. During the assessment of temperature, the anatomic data

from the MRI scan or the Doppler ultrasound is then referenced to ensure the proper degree of positioning and the degree of energy transduction is again further assessed by the modeling algorithm 4545 to set the parameters for the energy transducers 4550. If there is
5 movement of the target, the transducers may have to be turned off and the patient repositioned. Alternatively, the transducers can be redirected to a different position within the coordinate reference frame.

Ablation can also be augmented using agents such as magnetic
10 nanoparticles or liposomal nanoparticles which are responsive to a radiofrequency field generated by a magnet. These particles can be selectively heated by the magnetic field. The particles can also be enhanced such that they will target specific organs and tissues using targeting moieties such as antibodies, peptides, etc. In addition
15 to the delivery of heat, the particles can be activated to deliver drugs, bioactive agents, or imaging agents at the region at which action is desired (e.g. the renal artery). The particles can be introduced via an intravenous route, a subcutaneous route, a direct injection route through the blood vessel, or a percutaneous route. As
20 an example, magnetic nanoparticles or microparticles respond to a magnetic field by generating heat in a local region around them. Similarly, liposomal particles might have a metallic particle within such that the magnetic particle heats up the region around the liposome but the liposome allows accurate targeting and
25 biocompatibility.

The addition of Doppler ultrasound 4510 may be provided as well. The renal arteries are (if renal arteries or regions surrounding the arteries are the target) placed in a 3D coordinate reference frame
4530 using a software algorithm with or without the help of fiducial
30 markers. Data is supplied to ultrasound transducers 4540 from a heat modeling algorithm 4545 and the transducers are energized with the appropriate phase and power to heat the region of the renal artery to between 40°C and 90°C within a time span of several minutes. The

position within the 3D coordinate reference is also integrated into the treatment algorithm so that the ultrasound transducers can be moved into the appropriate position. The ultrasound transducers may have frequencies below 1 megahertz (MHz), from 1-20 MHz, or above 30
5 Mhz, or around 750 kHz, 500 kHz, or 250 kHz. The transducers may be in the form of a phased array, either linear or curved, or the transducers may be mechanically moved so as to focus ultrasound to the target of interest. In addition, MRI thermography 4570 can be utilized so as to obtain the actual temperature of the tissue being
10 heated. These data can be further fed into the system to slow down or speed up the process of ablation 4560 via the transducers 4550.

Aside from focused ultrasound, ultrasonic waves can be utilized directly to either heat an area or to activate pharmaceuticals in the region of interest. There are several methodologies to enhance drug
15 delivery using focused ultrasound. For example, particles can release pharmaceutical when they are heated by the magnetic field. Liposomes can release a payload when they are activated with focused ultrasound. Ultrasound waves have a natural focusing ability if a transducer is placed in the vicinity of the target and the target contains an
20 activateable moiety such as a bioactive drug or material (e.g. a nanoparticle sensitive to acoustic waves). Examples of sonodynamically activated moieties include some porphyrin derivatives.

So as to test the region of interest and the potential physiologic effect of ablation in that region, the region can be partially heated
25 or vibrated with the focused ultrasound to stun or partially ablate the nerves. Next, a physiologic test such as the testing of blood pressure or measuring norepinephrine levels in the blood, kidney, blood vessels leading to or from the kidney, can be performed to ensure that the correct region was indeed targeted for ablation.
30 Depending on the parameter, additional treatments may be performed.

Clinically, this technique might be called fractionation of therapy which underscores one of the major advantages of the technique to

apply external energy versus applying internal energy to the renal arteries. An internal technique requires invasion through the skin and entry into the renal artery lumens which is costly and potentially damaging. Patients will likely not accept multiple treatments, as
5 they are highly invasive and painful. An external technique allows for a less invasive treatment to be applied on multiple occasions, made feasible by the low cost and minimal invasion of the technology described herein.

In another embodiment, a fiducial is utilized to demarcate the region
10 of interest. A fiducial can be intrinsic (e.g. part of the anatomy) or the fiducial can be extrinsic (e.g. placed in position). For example, the fiducial can be an implanted fiducial, an intrinsic fiducial, or device placed in the blood vessels, or a device placed percutaneously through a catheterization or other procedure. The
15 fiducial can also be a bone, such as a rib, or another internal organ, for example, the liver. In one embodiment, the fiducial is a beacon or balloon or balloon with a beacon which is detectable via ultrasound. In one embodiment, the blood flow in the renal arteries, detected via Doppler or B-mode imaging, is the fiducial and its relative direction
20 is determined via Doppler analysis. Next, the renal arteries, and specifically, the region around the renal arteries are placed into a three dimensional coordinate frame utilizing the internal fiducials. A variant of global positioning system technology can be utilized to track the fiducials within the artery or around the arteries. In this
25 embodiment, a position sensor is placed in the artery or vein through a puncture in the groin. The position of the sensor is monitored as the sensor is placed into the blood vessel and its position in physical space relative to the outside of the patient, relative to the operator and relative to the therapeutic transducer is therefore
30 known. The three dimensional coordinate frame is transmitted to the therapeutic ultrasound transducers and then the transducers and anatomy are coupled to the same coordinate frame. At this point, the HIFU is delivered from the transducers, calculating the position of

the transducers based on the position of the target in the reference frame.

In one embodiment, a virtual fiducial is created via an imaging system. For example, in the case of a blood vessel such as the renal artery, an image of the blood vessel using B-mode ultrasound can be
5 obtained which correlates to the blood vessel being viewed in direct cross section (1705; figure 17F). When the vessel is viewed in this type of view, the center of the vessel can be aligned with the center 1700 of an ultrasound array (e.g. HIFU array 1600) and the transducers
10 can be focused and applied to the vessel, applying heat lesions 1680 to regions around the vessel 1705. With different positions of the transducers 1610 along a circumference or hemisphere 1650, varying focal points can be created 1620, 1630, 1640. The directionality of the transducers allows for a lesion(s) 1620, 1630, 1640 which run
15 lengthwise along the vessel 1700. Thus, a longitudinal lesion 1620-1640 can be produced along the artery to insure maximal inhibition of nerve function. In some embodiments, the center of the therapeutic ultrasound transducer is off center relative to the center of the vessel so that the energy is applied across the vessel wall at an
20 angle, oblique to the vessel.

In this method of treatment, an artery such as a renal artery is viewed in cross-section or close to a cross-section under ultrasound guidance. In this position, the blood vessel is substantially parallel to the axis of the spherical transducer so as to facilitate
25 lesion production. The setup of the ultrasound transducers 1600 has previously been calibrated to create multiple focal lesions 1620, 1630, 1640 along the artery if the artery is in cross-section 1680.

In one embodiment, the fiducial is an intravascular fiducial such as a balloon or a hermetically sealed transmitting device. The balloon is
30 detectable via radiotransmitter within the balloon which is detectable by the external therapeutic transducers. The balloon can have three transducers, each capable of relaying its position so that the balloon

can be placed in a three dimensional coordinate reference. Once the balloon is placed into the same coordinate frame as the external transducers using the transmitting beacon, the energy transducing devices can deliver energy (e.g. focused ultrasound) to the blood vessel (e.g. the renal arteries) or the region surrounding the blood vessels (e.g. the renal nerves). The balloon and transmitters also enable the ability to definitively track the vasculature in the case of movement (e.g. the renal arteries). In another embodiment, the balloon measures temperature or is a conduit for coolant applied during the heating of the artery or nerves.

Delivery of therapeutic ultrasound energy to the tissue inside the body is accomplished via the ultrasound transducers which are directed to deliver the energy to the target in the coordinate frame.

Once the target is placed in the coordinate frame and the energy delivery is begun, it is important to maintain targeting of the position, particularly when the target is a small region such as the sympathetic nerves. To this end, the position of the region of ablation is compared to its baseline position, both in a three dimensional coordinate reference frame. The ongoing positional monitoring and information is fed into an algorithm which determines the new targeting direction of the energy waves toward the target. In one embodiment, if the position is too far from the original position (e.g. the patient moves), then the energy delivery is stopped and the patient repositioned. If the position is not too far from the original position, then the energy transducers can be repositioned either mechanically (e.g. through physical movement) or electrically via phased array (e.g. by changing the relative phase of the waves emanating from the transducers). In another embodiment, multiple transducers are placed on the patient in different positions and each is turned on or off to result in the necessary energy delivery. With a multitude of transducers placed on the patient, a greater territory can be covered with the therapeutic ultrasound. The therapeutic

positions can also serve as imaging positions for intrinsic and/or extrinsic fiducials.

In addition to heat delivery, ultrasound can be utilized to deliver cavitating energy which may enable drug delivery at certain
5 frequencies. Cavitating energy can also lead to ablation of tissue at the area of the focus. A systemic dose of a drug can be delivered to the region of interest and the region targeted with the cavitating or other forms of ultrasonic energy. Other types of therapeutic delivery modalities include ultrasound sensitive bubbles or radiation sensitive
10 nanoparticles, all of which enhance the effect of the energy at the target of interest.

Figure 7E depicts the anatomy of the region 4600, the kidneys 4620, renal arteries 4630, and bony structures 4610, 4640 as viewed from behind a human patient. Figure 7E depicts the real world placement of
15 the renal arteries into coordinate frame as outlined in Figure 7D. Cross sectional CT scans from actual human patients were integrated to create a three-dimensional representation of the renal artery, kidney, and mid-torso region. Plane 4623 is a plane parallel to the transverse processes and angle 4607 is the angle one has to look up in
20 order to "see" the renal artery under the rib.

Figure 7F depicts an image of the region of the renal arteries and kidney 4605 using ultrasound. The renal hilum containing the arteries and vein 4640 can be visualized using this imaging modality. This image is typical when looking at the kidney and renal artery from the
25 direction and angle depicted in Figure 7E. Importantly, at the angle 4607 in 7E, there is no rib in the ultrasound path and there no other important structures in the path either.

An ultrasound imaging trial was then performed to detect the available windows to deliver therapeutic ultrasound to the region of the renal
30 arteries 4630 from the posterior region of the patient. It was discovered that the window depicted by arrow 4600 and depicted by arrow 4605 in the cross-sectional ultrasound image from ultrasound

(Figure 7F) provided optimal windows to visualize the anatomy of interest (renal pedicle 4640).

Figure 7G contains some of the important data from the trial 4700, the data in the "standard position 4730." These data 4720 can be used to
5 determine the configuration of the clinical HIFU system to deliver ultrasound to the renal hilum. The renal artery 4635 was determined to be 7-17 cm from the skin in the patients on average. The flank to posterior approach was noted to be optimum to image the renal artery, typically through the parenchyma of the kidney as shown in figure 7F
10 4605. The hilum 4640 of the kidney is approximately 4-8 cm from the ultrasound transducer and the angle of approach 4637 (4607 in Figure 7E) relative to an axis defined by the line connecting the two spinous processes and perpendicular to the spine...is approximately -10 to -48 degrees. It was also noted that the flank approach through the kidney
15 was the safest approach in that it represents the smallest chances of applying ultrasound to other organs such as bowel.

Upon further experimentation, it was discovered that by positioning the patient in the prone position (backside up, abdomen down), the structures under study 4750 ... that is, the renal arteries
20 4770 and 4780, the kidney hilum were even closer to the skin and the respiratory motion of the artery and kidney was markedly decreased. Figure 7H depicts these results 4750, 4760 showing the renal artery 4770 at 6-10 cm and the angle of approach 4790 relative to the spine 4607 shallower at -5 to -20 degrees.

25 Therefore, with these clinical data, in one embodiment, a method of treatment 4800 (Figure 7I) of the renal nerves in a patient has been devised: 1) identify the rib 4810 and iliac crest 4840 of a patient on the left and right flank of the patient 4810; 2) identify the left or right sided kidney with ultrasound 4820; 3) identify the
30 hilum of the kidney and the extent the renal hilum is visible along surface of patient 4820 using an imaging technology; 4) identify the blood vessels leading to the kidney from one or more angles,

extracting the extent of visibility 4860 along the surface area of the patient's back; 5) determine the distance to the one or more of the renal artery, renal vein, kidney, and the renal hilum 4850; 6) optionally, position patient in the prone position with a substantive positioning device underneath the back of the patient or overtop the abdomen of the patient 4830, to optimize visibility; 7) optionally determine, through modeling, the required power to obtain a therapeutic dose at the renal hilum and region around the renal blood vessels; 8) apply therapeutic energy to renal blood vessels; 9) optionally track the region of the blood vessels to ensure the continued delivery of energy to the region as planned in the modeling; 10) optionally, turning off delivery of energy in the case the focus of the energy is outside of the planned region.

Figure 8A depicts a percutaneous procedure and device 5010 in which the region around the renal artery 5030 is directly approached through the skin from an external position. A combination of imaging and application of energy (e.g. ablation) may be performed to ablate the region around the renal artery to treat hypertension, end stage renal disease, and heart failure. Probe 5010 is positioned through the skin and in proximity to the kidney 5030. The probe may include sensors at its tip 5020 which detect heat or temperature or may enable augmentation of the therapeutic energy delivery. Ablative, ionizing energy, heat, or light may be applied to the region to inhibit the sympathetic nerves around the renal artery using the probe 5010. Ultrasound, radiofrequency, microwave, direct heating elements, and balloons with heat or energy sources may be applied to the region of the sympathetic nerves. Imaging may be included on the probe or performed separately while the probe is being applied to the region of the renal blood vessels.

In one embodiment, the percutaneous procedure in Figure 8A is performed under MRI, CT, or ultrasound guidance to obtain localization or information about the degree of heat being applied. In one embodiment, ultrasound is applied but at a sub-ablative dose. That

is, the energy level is enough to damage or inhibit the nerves but the temperature is such that the nerves are not ablated but paralyzed or partially inhibited by the energy. A particularly preferred embodiment would be to perform the procedure under guidance from an MRI scanner because the region being heated can be determined anatomically in real time as well via temperature maps. As described above, the images after heating can be compared to those at baseline and the signals are compared at the different temperatures.

In one embodiment, selective regions of the kidney are ablated through the percutaneous access route; for example, regions which secrete hormones which are detrimental to a patient or to the kidneys or other organs. Using energy applied externally to the patient through the skin and from different angles affords the ability to target any region in or on the kidney or along the renal nerves or at the region of the adrenal gland, aorta, or sympathetic chain. This greater breadth in the number of regions to be targeted is enabled by the combination of external imaging and external delivery of the energy from a multitude of angles through the skin of the patient and to the target. The renal nerves can be targeted at their takeoff from the aorta onto the renal artery, at their synapses at the celiac ganglia, or at their bifurcation point along the renal artery.

In a further embodiment, probe 5010 can be utilized to detect temperature or motion of the region while the ultrasound transducers are applying the energy to the region. A motion sensor, position beacon, or accelerometer can be used to provide feedback for the HIFU transducers. In addition, an optional temperature or imaging modality may be placed on the probe 5010. The probe 5010 can also be used to locate the position within the laparoscopic field for the ablations to be performed. The dose delivered by this probe is approximately

In figure 8B, intravascular devices 5050, 5055 are depicted which apply energy to the region around the renal arteries 5065 from within the renal arteries. The intravascular devices can be utilized to

apply radiofrequency, ionizing radiation, and/or ultrasound (either focused or unfocused) energy to the renal artery and surrounding regions. MRI or ultrasound or direct thermometry can be further utilized to detect the region where the heat is being applied while
5 the intravascular catheter is in place.

In one embodiment, devices 5050, 5055 (Figure 8B) apply ultrasound energy which inhibits nerve function not by heating, but by mechanisms such as periodic pressure changes, radiation pressure, streaming or flow in viscous media, and pressures associated with cavitation,
10 defined as the formation of holes in liquid media. Heat can selectively be added to these energies but not to create a temperature which ablates the nerves, only facilitates the mechanism of vibration and pressure. In this embodiment, the ultrasound is not focused but radiates outward from the source to essentially create a cylinder of
15 ultrasonic waves that intersect with the wall of the blood vessel. An interfacial material between the ultrasound transducer and the wall of the artery may be provided such that the ultrasound is efficiently transducted through the arterial wall to the region of the nerves around the artery. In another embodiment, the ultrasound directly
20 enters the blood and propagates through the ultrasound wall to affect the nerves. In some embodiments, cooling is provided around the ultrasound catheter which protects the inside of the vessel yet allows the ultrasound to penetrate through the wall to the regions outside the artery. A stabilization method for the ultrasound probe is also
25 included in such a procedure. The stabilization method might include a stabilizing component added to the probe and may include a range finding element component of the ultrasound so that the operator knows where the ultrasound energy is being applied.

Imaging can be performed externally or internally in this embodiment
30 in which a catheter is placed inside the renal arteries. For example, external imaging with MRI or Ultrasound may be utilized to visualize changes during the ultrasound modulation of the nerve bundles. Indeed, these imaging modalities may be utilized for the application

of any type of energy within the wall of the artery. For example, radiofrequency delivery of energy through the wall of the renal artery may be monitored through similar techniques. Thus the monitoring of the procedural success of the technique is independent of the
5 technique in most cases.

Alternatively, in another embodiment, the devices 5050, 5055 can be utilized to direct externally applied energy (e.g. ultrasound) to the correct place around the artery as the HIFU transducers deliver the energy to the region. For example, the intravascular probe 5050 can
10 be utilized as a homing beacon for the imaging/therapeutic technology utilized for the externally delivered HIFU.

Figure 8C depicts a percutaneous procedure to inhibit the renal sympathetic nerves. Probe 5010 is utilized to approach the renal hilum 5060 region from posterior and renal artery 5065. With the data
15 presented below, the probe can be armed with HIFU to denervate the region. The data presented below indicates the feasibility of this approach as far as ultrasound enabling denervation of the vessels quickly and easily.

In another embodiment, the physiologic process of arterial expansion (aneurysms) is targeted. In figure 9a, an ultrasound transducer is
20 6005 is placed near the wall of an aneurysm 6030. Ultrasonic energy 6015 is applied to the wall 6030 of the aneurysm to thicken the wall and prevent further expansion of the aneurysm. In some embodiments, clot within the aneurysm is targeted as well so that the clot is
25 broken up or dissolved with the ultrasonic energy. Once the wall of the aneurysm is heated with ultrasonic energy to a temperature of between 40 and 70 degrees, the collagen, elastin, and other extracellular matrix in the wall will harden as it cools, thereby preventing the wall from further expansion.

30 In another embodiment, a material is placed in the aneurysm sac and the focused or non-focused ultrasound utilized to harden or otherwise induce the material in the sac to stick to the aorta or clot in the

aneurysm and thus close the aneurysm permanently. In one embodiment therefore, an ultrasound catheter is placed in an aorta at the region of an aneurysm wall or close to a material in an aneurysmal wall. The material can be a man-made material placed by an operator or it can be
5 material such as thrombus which is in the aneurysm naturally. Ultrasound is applied to the wall, or the material, resulting in hardening of the wall or of the material, strengthening the aneurysm wall and preventing expansion. The energy can also be applied from a position external to the patient or through a percutaneously
10 positioned energy delivering catheter.

Figure 9b 6000 depicts a clot prevention device 6012 (vena cava filter) within a blood vessel such as the aorta or vena cava 6010. The ultrasound catheter 6005 is applied to the clot prevention device (filter) 6012 so as to remove the clot from the device or to free the
15 device 6012 from the wall of the blood vessel in order to remove it from the blood vessel 6000.

Figure 9c depicts a device and method in which the celiac plexus 6020 close to the aorta 6000 is ablated or partially heated using heat or vibrational energy from an ultrasonic energy source 6005 which can
20 apply focused or unfocused sound waves 6007 at frequencies ranging from 20 kilohertz to 5 Mhz and at powers ranging from 1 mW to over 100 kW in a focused or unfocused manner. Full, or partial ablation of the celiac plexus 6020 can result in a decrease in blood pressure via a similar mechanism as applying ultrasonic energy to the renal nerves;
25 the ablation catheter is a focused ultrasound catheter but can also be a direct (unfocused) ultrasonic, a microwave transducer, or a resistive heating element. Energy can also be delivered from an external position through the skin to the aorta or celiac plexus region.

30 Figure 10 depicts a method 6100 to treat a patient with high intensity or low intensity focused ultrasound (HIFU or LIFU) 6260. In a first step, a CT and/or MRI scan and/or thermography and/or ultrasound

(1D,2D,3D) is performed 6110. A fiducial or other marking on or in the patient 6120 is optionally used to mark and track 6140 the patient. The fiducial can be an implanted fiducial, a temporary fiducial placed internally or externally in or on the patient, or a 5 fiducial intrinsic to the patient (e.g. bone, blood vessel, arterial wall) which can be imaged using the CT/MRI/Ultrasound devices 6110. The fiducial can further be a temporary fiducial such as a catheter temporarily placed in an artery or vein of a patient or a percutaneously placed catheter. A planning step 6130 for the HIFU 10 treatment is performed in which baseline readings such as position of the organ and temperature are determined; a HIFU treatment is then planned using a model (e.g. finite element model) to predict heat transfer, or pressure to heat transfer, from the ultrasound transducers 6130. The planning step incorporates the information on 15 the location of the tissue or target from the imaging devices 6110 and allows placement of the anatomy into a three dimensional coordinate reference such that modeling 6130 can be performed.

The planning step 6130 includes determination of the positioning of the ultrasound transducers as far as position of the focus in the 20 patient. X,Y,Z, and up to three angular coordinates are used to determine the position of the ultrasonic focus in the patient based on the cross sectional imaging 6110. The HIFU transducers might have their own position sensors built in so that the position relative to the target can be assessed. Alternatively, the HIFU transducers can 25 be rigidly fixed to the table on which the patient rests so that the coordinates relative to the table and the patient are easily obtainable. The flow of heat is also modeled in the planning step 6130 so that the temperature at a specific position with the ultrasound can be planned and predicted. For example, the pressure 30 wave from the transducer is modeled as it penetrates through the tissue to the target. For the most part, the tissue can be treated as water with a minimal loss due to interfaces. Modeling data predicts that this is the case. The relative power and phase of the ultrasonic

wave at the target can be determined by the positional coupling between the probe and target. A convective heat transfer term is added to model heat transfer due to blood flow, particularly in the region of an artery. A conductive heat transfer term is also modeled
5 in the equation for heat flow and temperature.

Another variable which is considered in the planning step is the size of the lesion and the error in its position. In the ablation of small regions such as nerves surrounding blood vessels, the temperature of the regions may need to be increased to a temperature of 60-90 degrees
10 Celsius to permanently ablate nerves in the region. Temperatures of 40-60 degrees may temporarily inhibit or block the nerves in these regions and these temperatures can be used to determine that a patient will respond to a specific treatment without permanently ablating the nerve region. Subsequently, additional therapy can be applied at a
15 later time so as to complete the job or perhaps, re-inhibit the nerve regions.

An error analysis is also performed during the treatment contemplated in Figure 10. Each element of temperature and position contains an error variable which propagates through the equation of the treatment.
20 The errors are modeled to obtain a virtual representation of the temperature mapped to position. This map is correlated to the position of the ultrasound transducers in the treatment of the region of interest.

During the delivery of the treatment 6260, the patient may move, in
25 which case the fiducials 6120 track the movement and the position of the treatment zone is re-analyzed 6150 and the treatment is restarted or the transducers are moved either mechanically or electrically to a new focus position.

In another embodiment, a cross-sectional technique of imaging is used
30 in combination with a modality such as ultrasound to create a fusion type of image. The cross-sectional imaging is utilized to create a three dimensional data set of the anatomy. The ultrasound, providing

two dimensional images, is linked to the three dimensional imaging provided by the cross-sectional machine through fiducial matches between the ultrasound and the MRI. As a body portion moves within the ultrasound field, the corresponding data is determined (coupled to) the cross-sectional (e.g. MRI image) and a viewing station can show the movement in the three dimensional dataset. The ultrasound provides real time images and the coupling to the MRI or other cross-sectional image depicts the ultrasound determined position in the three dimensional space.

Figure 11 depicts the treatment 7410 of another disease in the body of a patient, this time in the head of a patient. Subdural and epidural hematomas occur as a result of bleeding of blood vessels in the dural or epidural spaces of the brain, spinal column, and scalp. Figure 11 depicts a CT or MRI scanner 7300 and a patient 7400 therein. An image is obtained of the brain 7000 using a CT or MRI scan. The image is utilized to couple the treatment zone 7100 to the ultrasound array utilized to heat the region. In one embodiment 7100, a subdural hematoma, either acute or chronic, is treated. In another embodiment 7200, an epidural hematoma is treated. In both embodiments, the region of leaking capillaries and blood vessels are heated to stop the bleeding, or in the case of a chronic subdural hematoma, the oozing of the inflammatory capillaries.

In an exemplary embodiment of modulating physiologic processes, a patient 7400 with a subdural or epidural hematoma is chosen for treatment and a CT scan or MRI 7300 is obtained of the treatment region. Treatment planning ensues and the chronic region of the epidural 7200 or sub-dural 7010 hematoma is targeted for treatment with the focused ultrasound 7100 transducer technology. Next the target of interest is placed in a coordinate reference frame as are the ultrasound transducers. Therapy 7100 ensues once the two are coupled together. The focused ultrasound heats the region of the hematoma to dissolve the clot and/or stop the leakage from the capillaries which lead to the accumulation of fluid around the brain

7420. The technology can be used in place of or in addition to a burr hole, which is a hole placed through the scalp to evacuate the fluid.

Figure 12 depicts a laparoscopic based approach 8000 to the renal artery region in which the sympathetic nerves 8210 can be ligated, interrupted, or otherwise modulated. In laparoscopy, the abdomen of a patient is insufflated and laparoscopic instruments introduced into the insufflated abdomen. The retroperitoneum is easily accessible through a flank approach or (less so) through a transabdominal (peritoneal) approach. A laparoscopic instrument 8200 with a distal tip 8220 can apply heat or another form of energy or deliver a drug to the region of the sympathetic nerves 8210. The laparoscopic instrument can also be utilized to ablate or alter the region of the celiac plexus 8300 and surrounding ganglia. The laparoscope can have an ultrasound transducer 8220 attached, a temperature probe attached, a microwave transducer attached, or a radiofrequency transducer attached. The laparoscope can be utilized to directly ablate or stun the nerves (e.g. with a lower frequency/energy) surrounding vessels or can be used to ablate or stun nerve ganglia which travel with the blood vessels. Similar types of modeling and imaging can be utilized with the percutaneous approach as with the external approach to the renal nerves. With the discovery through animal experimentation (see below) that a wide area of nerve inhibition can be affected with a single ultrasound probe in a single direction (see above), the nerve region does not have to be directly contacted with the probe, the probe instead can be directed in the general direction of the nerve regions and the ultrasound delivered. For example, the probe can be placed on one side of the vessel and activated to deliver focused or semi-focused ultrasound over a generalized region which might not contain greater than 1 cm of longitudinal length of the artery but its effect is enough to completely inhibit nerve function along.

Figure 13 depicts an algorithm 8400 for the treatment of a region of interest using directed energy from a distance. MRI and/or CT with or without an imaging agent 8410 can be utilized to demarcate the region

of interest (for example, the ablation zone) and then ablation 8420 can be performed around the zone identified by the agent using any of the modalities above. This algorithm is applicable to any of the therapeutic modalities described above including external HIFU, 5 laparoscopic instruments, intravascular catheters, percutaneous catheters and instruments, as well as any of the treatment regions including the renal nerves, the eye, the kidneys, the aorta, or any of the other nerves surrounding peripheral arteries or veins. Imaging 8430 with CT, MRI, ultrasound, or PET can be utilized in real time to visualize the region being ablated. At such time when destruction of 10 the lesion is complete 8440, imaging with an imaging (for example, a molecular imaging agent or a contrast agent such as gadolinium) agent 8410 can be performed again. The extent of ablation can also be monitored by monitoring the temperature or the appearance of the 15 ablated zone under an imaging modality. Once lesion destruction is complete 8440, the procedure is finished. In some embodiments, ultrasonic diagnostic techniques such as elastography are utilized to determine the progress toward heating or ablation of a region.

Figure 14 depicts ablation in which specific nerve fibers of a 20 nerve are targeted using different temperature gradients, power gradients, or temperatures 8500. For example, if temperature is determined by MRI thermometry or with another technique such as ultrasound, infrared thermography, or a thermocouple, then the temperature can be kept at a temperature in which only certain nerve 25 fibers are targeted for destruction or inhibition. Alternatively, part or all of the nerve can be turned off temporarily to then test the downstream effect of the nerve being turned off. For example, the sympathetic nerves around the renal artery can be turned off with a small amount of heat or other energy (e.g. vibrational energy) and 30 then the effect can be determined. For example, norepinephrine levels in the systemic blood, kidney, or renal vein can be assayed; alternatively, the stimulation *effect* of the nerves can be tested after temporary cessation of activity (e.g. skin reactivity, blood

pressure lability, cardiac activity, pulmonary activity, renal artery constriction in response to renal nerve stimulation). For example, in one embodiment, the sympathetic activity within a peripheral nerve is monitored; sympathetic activity typically manifests as spikes within a peripheral nerve electrical recording. The number of spike
5 correlates with the degree of sympathetic activity or over-activity. When the activity is decreased by (e.g. renal artery de-inervation), the concentration of spikes in the peripheral nerve train is decreased, indicating a successful therapy of the sympathetic or
10 autonomic nervous system. Varying frequencies of vibration can be utilized to inhibit specific nerve fibers versus others. For example, in some embodiments, the efferent nerve fibers are inhibited and in other embodiments, the afferent nerve fibers are inhibited. In some embodiments, both types of nerve fibers are inhibited, temporarily or
15 permanently. In some embodiments, the C fibers 8520 are selectively blocked at lower heat levels than the A nerve fibers. In other embodiment, the B fibers are selectively treated or blocked and in some embodiments, the A fibers 8530 are preferentially blocked. In some embodiments, all fibers are inhibited by suturing the nerve with
20 a high dose of ultrasound 8510. Based on the experimentation described above, the power density to achieve full blockage might be around $100\text{-}800\text{ W/cm}^2$ or with some nerves from about $500\text{ to }2500\text{ W/cm}^2$. In some embodiments, a pulse train of 100 or more pulses each lasting 1-2 seconds (for example) and delivering powers from about 50 w/cm^2 to
25 500 W/cm^2 . Indeed, prior literature has shown that energies at or about 100W/Cm^2 is adequate to destroy or at least inhibit nerve function (Lele, PP. Effects of Focused Ultrasound Radiation on Peripheral Nerve, with Observations on Local Heating. Experimental Neurology 8, 47-83 1963 incorporated by reference).

30 Figure 15a depicts treatment 8600 of a vertebral body or intervertebral disk 8610 in which nerves within 8640 or around the vertebral column 8630 are targeted with energy 8625 waves. In one embodiment, nerves around the facet joints are targeted. In another

embodiment, nerves leading to the disks or vertebral endplates are targeted. In another embodiment, nerves within the vertebral bone 8630 are targeted by heating the bone itself. Sensory nerves run through canals 8635 in the vertebral bone 8630 and can be inhibited or
5 ablated by heating the bone 8630.

Figure 15B depicts a close-up of the region of the facet joint. Focused ultrasound to this region can inhibit nerves involved in back pain which originate at the dorsal root nerve and travel to the facet joint 8645. Ablation or inhibition of these nerves can limit or even
10 cure back pain due to facet joint arthropathy. Focused ultrasound can be applied to the region of the facet joint from a position outside the patient to the facet joint using powers of between 100 W/cm² and 2500 W/cm² at the nerve from times ranging from 1 second to 10 minutes.

Figure 16A depicts a set of lesion types, sizes, and anatomies 8710a-f
15 which lead to de-innervation of the different portions of the sympathetic nerve tree around the renal artery. For example, the lesions can be annular, cigar shaped, linear, doughnut and/or spherical; the lesions can be placed around the renal arteries 8705, inside the kidney 8710, and/or around the aorta 8700. For example,
20 the renal arterial tree comprises a portion of the aorta 8700, the renal arteries 8705, and kidneys 8715. Lesions 8714 and 8716 are different types of lesions which are created around the aorta 8700 and vascular tree of the kidneys. Lesions 8712 and 8718 are applied to the pole branches from the renal artery leading to the kidney and inhibit
25 nerve functioning at branches from the main renal artery. These lesions also can be applied from a position external to the patient. Lesions can be placed in a spiral shape 8707 along the length of the artery as well. These lesions can be produced using energy delivered from outside the blood vessels using a completely non-invasive
30 approach in which the ultrasound is applied through the skin to the vessel region or the energy can be delivered via percutaneous approach. Either delivery method can be accomplished through the

posterior approach to the blood vessels as discovered and described above.

In one method therefore, ultrasound energy can be applied to the blood vessel leading to a kidney in a pattern such that a circular pattern
5 of heat and ultrasound is applied to the vessel. The energy is transmitted through the skin in one embodiment or through the artery in another embodiment. As described below, ultrasound is transmitted from a distance and is inherently easier to apply in a circular pattern because it doesn't only rely on conduction.

10 Previously, it was unknown and undiscovered whether or not the annular shaped lesions as shown in figure 16a would have been sufficient to block nerve function of the autonomic nerves around the blood vessels. Applicant of the subject application discovered that the annular
15 shaped ablations 8710 not only block function but indeed completely block nerve function around the renal artery and kidney and with very minimal damage (Figure 16C), if any, to the arteries and veins themselves. In these experiments, focused ultrasound was used to block the nerves; the ultrasound was transmitted through and around the vessel from the top (that is, only one side of the vessel) at
20 levels of 200-2500 W/cm². Simulations are shown in figure 16B and described below. Norepinephrine levels in the kidney 8780, which are utilized to determine the degree of nerve inhibition, were determined before and after application of energy. The lower the levels of norepinephrine, the more nerves which have been inhibited. In these
25 experiments which were performed, the norepinephrine levels approached zero 8782 versus controls 8784 which remained high. In fact, the levels were equal to or lower than the surgically denuded blood vessels (surgical denudement involves directly cutting the nerves surgically). It is important that the renal artery and vein walls were
30 remained substantially unharmed; this is likely due to the fact that the quick arterial blood flow removes heat from the vessel wall and the fact that the main renal artery is extremely resilient due to its large size, high blood flow, and thick wall. To summarize, ultrasound

(focused and relatively unfocused) was applied to one side of the renal artery and vein complex. The marker of nerve inhibition, norepinephrine levels inside the kidney, were determined to be approaching zero after application to the nerves from a *single* direction, transmitting the energy through the artery wall to reach nerves around the circumference of the artery. The level of zero norepinephrine 8782 indicates essentially complete abolition of nerve function proving that the annular lesions were in fact created as depicted in figure 16A and simulated in Figure 16B. Histological results also confirm the annular nature of the lesions and limited collateral damage as predicted by the modeling in 16B.

Therefore, in one embodiment, the ultrasound is applied from a position external to the artery in such a manner so as to create an annular or semi-annular rim of heat all the way around the artery to inhibit, ablate, or partially ablate the autonomic nerves surrounding the artery. The walls or the blood flow of the artery can be utilized to target the ultrasound to the nerves which, if not directly visualized, are visualized by use of a model to approximate the position of the nerves based on the position of the blood vessel.

Figure 16B further supports the physics and physiology described herein, depicting a theoretical simulation 8750 of the physical and animal experimentation described above. That is, focused ultrasound was targeted to a blood vessel in a computer simulation 8750. The renal artery 8755 is depicted within the heating zone generated within a focused ultrasound field. Depicted is the temperature at <1s 8760 and at approximately 5s 8765 and longer time > 10s 8767. Flow direction 8770 is shown as well. The larger ovals depict higher temperatures with the central temperature >100°C. The ultrasound field is transmitted *through* the artery 8755, with heat building up around the artery as shown via the temperature maps 8765. Importantly, this theoretical simulation also reveals the ability of the ultrasound to travel through the artery and affect both walls of the blood

vessel. These data are consistent with the animal experimentation described above, creating a unified physical and experimental dataset.

Therefore, based on the animal and theoretical experimentation, there is proven feasibility of utilizing ultrasound to quickly and
5 efficiently inhibit the nerves around the renal arteries from a position external to the blood vessels as well as from a position external to the skin of the patient.

Utilizing the experimental simulations and animal experimentation described above, a clinical device can and has been devised and tested
10 in human patients. Figure 17A depicts a multi-transducer HIFU device 1100 which applies a finite lesion 1150 along an artery 1140 (e.g. a renal artery) leading to a kidney 1130. The lesion can be spherical in shape, cigar shaped 1150, annular shaped 8710 (Figure 16A), or point shaped; however, in a preferred embodiment, the lesion runs along the
15 length of the artery and has a cigar shaped 1150. This lesion is generated by a spherical or semi-spherical type of ultrasound array in a preferred embodiment. Multiple cigar shaped lesion as shown in Figure 17C leads to a ring type of lesion 1350.

Figure 17B depicts an imaging apparatus display which monitors
20 treatment. Lesion 1150 is depicted on the imaging apparatus as is the aorta 1160 and renal artery 1155. The image might depict heat, tissue elastography, vibrations, or might be based on a simulation of the position of the lesion 1150. Figure 17C depicts another view of the treatment monitoring, with the renal artery in cross section 1340.
25 Lesion 1350 is depicted in cross section in this image as well. The lesion 1350 might be considered to circumscribe the vessel 1340 in embodiments where multiple lesions are applied.

Figure 17D depicts a methodology 1500 to analyze and follow the delivery of therapeutic focused ultrasound to an arterial region. A
30 key step is to first position 1510 the patient optimally to image the treatment region; the imaging of the patient might involve the use of Doppler imaging, M mode imaging, A scan imaging, or even MRI or CT

scan. The imaging unit is utilized to obtain coordinate data 1530 from the doppler shift pattern of the artery. Next, the focused ultrasound probe is positioned 1520 relative to the imaged treatment region 1510 and treatment can be planned or applied.

- 5 Figure 17E depicts the pathway of the acoustic waves from a spherical or cylindrical type of ultrasound array 1600. In some embodiments, the transducer is aspherical such that a sharp focus does not exist but rather the focus is more diffuse in nature or off the central axis. Alternatively, the asphericity might allow for different
- 10 pathlengths along the axis of the focusing. For example, one edge of the ultrasound transducer might be called upon for 15 cm of propagation while another edge of the transducer might be called upon to propagate only 10 cm, in which case a combination of difference frequencies or angles might be required.
- 15 Ultrasound transducers 1610 are aligned along the edge of a cylinder 1650, aimed so that they intersect at one or more focal spots 1620, 1630, 1640 around the vessel (e.g. renal artery). The transducers 1610 are positioned along the cylinder or sphere or spherical approximation (e.g. aspherical) 1650 such that several of the
- 20 transducers are closer to one focus or the other such that a range of distances 1620, 1630, 1640 to the artery is created. The patient and artery are positioned such that their centers 1700 co-localize with the center of the ultrasound array 1600. Once the centers are co-localized, the HIFU energy can be activated to create lesions along
- 25 the length of the artery wall 1640, 1620, 1630 at different depths and positions around the artery. The natural focusing of the transducers positioned along a cylinder as in figure 17E is a lengthwise lesion, longer than in thickness or height, which will run along the length of an artery 1155 when the artery 1340 is placed along the center axis of
- 30 the cylinder. When viewed along a cross section (Figure 17F), the nerve ablations are positioned along a clock face 1680 around the blood vessel.

In another embodiment, a movement system for the transducers is utilized so that the transducers move along the rim of the sphere or cylinder to which they are attached. The transducers can be moved automatically or semi-automatically, based on imaging or based on external position markers. The transducers are independently controlled electrically but coupled mechanically through the rigid structure.

Importantly, during treatment, a treatment workstation 1300 (Figure 17C) gives multiple views of the treatment zone with both physical appearance and anatomy 1350. Physical modeling is performed in order to predict lesion depth and the time to produce the lesion; this information is fed back to the ultrasound transducers 1100. The position of the lesion is also constantly monitored in a three dimensional coordinate frame and the transducer focus at lesions center 1150 in the context of monitoring 1300 continually updated.

In some embodiments, motion tracking prevents the lesion or patient from moving too far out of the treatment zone during the ablation. If the patient does move outside the treatment zone during the therapy, then the therapy can be stopped. Motion tracking can be performed using the ultrasound transducers, tracking frames and position or with transducers from multiple angles, creating a three dimensional image with the transducers. Alternatively, a video imaging system can be used to track patient movements, as can a series of accelerometers positioned on the patient which indicate movement.

Figure 18 depicts a micro-catheter 8810 which can be placed into renal calyces 8820; this catheter allows the operator to specifically ablate or stimulate 8830 regions of the kidney 8800. The catheter can be used to further allow for targeting of the region around the renal arteries and kidneys by providing additional imaging capability or by assisting in movement tracking or reflection of the ultrasound waves to create or position the lesion. The catheter or device at or near the end of the catheter may transmit signals outside the patient to

direct an energy delivery device which delivers energy through the skin. Signaling outside the patient may comprise energies such as radiofrequency transmission outside the patient or radiofrequency from outside to the inside to target the region surrounding the catheter.

5 The following patent and patent applications describe the delivery of ultrasound using a targeting catheter within a blood vessel, and are expressly incorporated by reference herein:

11/583569, 12/762938, 11/583656, 12/247969, 10/633726, 09/721526,
10/780405, 09/747310, 12/202195, 11/619996, 09/696076

10 In one system 8800, a micro catheter 8810 is delivered to the renal arteries and into the branches of the renal arteries in the kidney 8820. A signal is generated from the catheter into the kidney and out of the patient to an energy delivery system. Based on the generated signal, the position of the catheter in a three dimensional coordinate
15 reference is determined and the energy source is activated to deliver energy 8830 to the region indicated by the microcatheter 8810.

In an additional embodiment, station keeping is utilized. Station keeping enables the operator to maintain the position of the external energy delivery device with respect to the movement of the operator or
20 movement of the patient. As an example, targeting can be achieved with the energy delivery system and

The microcatheter may be also be utilized to place a flow restrictor inside the kidney (e.g. inside a renal vein) to "trick" the kidney into thinking its internal pressure is higher than it might be. In
25 this embodiment, the kidney generates signals to the central nervous system to lower sympathetic output to target organs in an attempt to decrease its perfusion pressure.

Alternatively, specific regions of the kidney might be responsible for hormone excretion or other factors which lead to hypertension or other
30 detrimental effects to the cardiovascular system. The microcatheter can generate ultrasound, radiofrequency, microwave, or X-ray energy.

The microcatheter can be utilized to ablate regions in the renal vein or intra-parenchymal venous portion as well. In some embodiments, ablation is not required but vibratory energy emanating from the probe is utilized to affect, on a permanent or temporary basis, the
5 mechanoreceptors or chemoreceptors in the location of the hilum of the kidney.

Figure 19A depicts the application 8900 of energy to the region of the renal artery 8910 and kidney 8920 using physically separated transducers 8930, 8931. Although two are shown, the transducer can be
10 a single transducer which is connected all along. The transducer(s) can be spherical or aspherical, they can be couple to an imaging transducer directly or indirectly where the imaging unit might be separated at a distance. In contrast to the delivery method of figure 17, figure 19A depicts delivery of ultrasound transverse to the
15 renal arteries and not longitudinal to the artery. The direction of energy delivery is the posterior of the patient because the renal artery is the first vessel "seen" when traveling from the skin toward the anterior direction facilitating delivery of the therapy. In one embodiment, the transducers 8930, 8931 are placed under, or inferior
20 to the rib of the patient or between the ribs of a patient; next, the transducers apply an ultrasound wave propagating forward toward the anterior abdominal wall and image the region of the renal arteries and renal veins, separating them from one another. In some embodiments, such delivery might be advantageous, if for example, a longitudinal
25 view of the artery is unobtainable or a faster treatment paradigm is desirable. The transducers 8930, 8931 communicate with one another and are connected to a computer model of the region of interest being imaged (ROI), the ROI based on an MRI scan performed just prior to the start of the procedure and throughout the procedure. Importantly, the
30 transducers are placed posterior in the cross section of the patient, an area with more direct access to the kidney region. The angle between the imaging transducers can be as low as 3 degrees or as great as 180 degrees depending on the optimal position in the patient.

In another embodiment, an MRI is not performed but ultrasound is utilized to obtain all or part of the cross-sectional view in Figure 19A. For example, 8930 might contain an imaging transducer as well as a therapeutic energy source (e.g. ionizing energy, HIFU, low energy
5 focused ultrasound, etc.)

Figure 19B depicts an ultrasound image from a patient illustrating imaging of the region with patient properly positioned as described below. It is this cross section that can be treated with image guided HIFU of the renal hilum region. The kidney 8935 is visualized in
10 cross section and ultrasound then travels through to the renal artery 8937 and vein 8941. The distance can be accurately measure 8943 with ultrasound (in this case 8 cm 8943). This information is useful to help model the delivery of energy to the renal blood vessels.

Figure 20 depicts an alternative method, system 9000 and device to
15 ablate the renal nerves 9015 or the nerves leading to the renal nerves at the aorta-renal artery ostium 9010. The intravascular device 9020 is placed into the aorta 9050 and advanced to the region of the renal arteries 9025. Energy is applied from the transducer 9020 and focused 9040 (in the case of HIFU, LIFU, ionizing radiation) to the region of
20 the takeoff of the renal arteries 9025 from the aorta 9050. This intravascular 9030 procedure can be guided using MRI and/or MRI thermometry or it can be guided using fluoroscopy, ultrasound, or MRI. Because the aorta is larger than the renal arteries, the HIFU catheter can be placed into the aorta directly and cooling catheters can be
25 included as well. In addition, in other embodiments, non-focused ultrasound can be applied to the region around the renal ostium or higher in the aorta. Non-focused ultrasound in some embodiments may require cooling of the tissues surrounding the probe using one or more coolants but in some embodiments, the blood of the aorta will take the
30 place of the coolant, by its high flow rate; HIFU, or focused ultrasound, may not need the cooling because the waves are by definition focused from different angles to the region around the aorta. The vena cava and renal veins can also be used as a conduit

for the focused ultrasound transducer to deliver energy to the region as well. In one embodiment, the vena cava is accessed and vibratory energy is passed through the walls of the vena cava and renal vein to the renal arteries, around which the nerves to the kidney travel. The
5 veins, having thinner walls, allow energy to pass through more readily.

Figure 21a-b depicts an eyeball 9100. Also depicted are the zonules of the eye 9130 (the muscles which control lens shape) and ultrasound transducer 9120. The transducer 9120 applies focused ultrasound
10 energy to the region surrounding the zonules, or the zonules themselves, in order to tighten them such that a presbyopic patient can accommodate and visualize object up close. Similarly, heat or vibration applied to the ciliary muscles, which then increases the outflow of aqueous humor at the region of interest so that the
15 pressure within the eye cannot build up to a high level. The ultrasound transducer 9120 can also be utilized to deliver drug therapy to the region of the lens 9150, ciliary body, zonules, intra-vitreous cavity, anterior cavity 9140, posterior cavity, etc.

In some embodiments (Fig. 21b), multiple transducers 9160 are utilized
20 to treat tissues deep within the eye; the ultrasonic transducers 9170 are focused on the particular region of the eye from multiple directions so that tissues along the path of the ultrasound are not damaged by the ultrasound and the focus region and region of effect 9180 is the position where the waves meet in the eye. In one
25 embodiment, the transducers are directed through the pars plana region of the eye to target the macula 9180 at the posterior pole 9175 of the eye. This configuration might allow for heat, vibratory stimulation, drug delivery, gene delivery, augmentation of laser or ionizing radiation therapy, etc. In certain embodiments, focused ultrasound is
30 not required and generic vibratory waves are transmitted through the eye at frequencies from 20 kHz to 10 MHz. Such energy may be utilized to break up clots in, for example, retinal venous or arterial occlusions which are creating ischemia in the retina. This energy can

be utilized in combination with drugs utilized specifically for breaking up clots in the veins of the retina.

Figure 22 depicts a peripheral joint 9200 being treated with heat and/or vibrational energy. Ultrasound transducer 9210 emits waves
5 toward the knee joint to block nerves 9260 just underneath the bone periostium 92209250 or underneath the cartilage. Although a knee joint is depicted, it should be understood that many joints can be treated including small joints in the hand, intervertebral joints, the hip, the ankle, the wrist, and the shoulder. Unfocused or focused
10 ultrasonic energy can be applied to the joint region to inhibit nerve function reversibly or irreversibly. Such inhibition of nerve function can be utilized to treat arthritis, post-operative pain, tendonitis, tumor pain, etc. In one preferred embodiment, vibratory energy can be utilized rather than heat. Vibratory energy applied to
15 the joint nerves can inhibit their functioning such that the pain fibers are inhibited.

Figure 23a-b depicts closure of a fallopian tube 9300 of a uterus 9320 using externally applied ultrasound 9310 so as to prevent pregnancy. MRI or preferably ultrasound can be utilized for the imaging modality.
20 Thermometry can be utilized as well so as to see the true ablation zone in real time. The fallopian tube 9300 can be visualized using ultrasound, MRI, CT scan or a laparoscope. Once the fallopian tube is targeted, external energy 9310, for example, ultrasound, can be utilized to close the fallopian tube to prevent pregnancy. When heat
25 is applied to the fallopian tube, the collagen in the walls are heated and will swell, the walls then contacting one another and closing the fallopian preventing full ovulation and therefore preventing pregnancy. Although there is no doppler signal in the fallopian tube, the technology for visualization and treatment is similar to that for
30 an artery or other duct. That is, the walls of the tube are identified and modeled, then focused ultrasound is applied through the skin to the fallopian tube to apply heat to the walls of the lumen of the fallopian tube.

In Figure 23b, a method is depicted in which the fallopian tubes are visualized 9340 using MRI, CT, or ultrasound. HIFU 9350 is applied under visualization with MRI or ultrasound. As the fallopian tubes are heated, the collagen in the wall is heated until the walls of the fallopian tube close off. At this point the patient is sterilized 9360. During the treating time, it may be required to determine how effective the heating is progressing. If additional heat is required, then additional HIFU may be added to the fallopian tubes until there is closure of the tube and the patient is sterilized 9360. Such is one of the advantages of the external approach in which multiple treatments can be applied to the patient, each treatment closing the fallopian tubes further, the degree of success then assessed after each treatment. A further treatment can then be applied 9370.

In other embodiments, ultrasound is applied to the uterus or fallopian tubes to aid in pregnancy by improving the receptivity of the sperm and/or egg for one another. This augmentation of conception can be applied to the sperm and egg outside of the womb as well, for example, in a test tube in the case of extra-uterine fertilization.

Figure 24 depicts a feedback algorithm to treat the nerves of the autonomic nervous system. It is important that there be an assessment of the response to the treatment afterward. Therefore, in a first step, modulation of the renal nerves 9400 is accomplished by any or several of the embodiments discussed above. An assessment 9410 then ensues, the assessment determining the degree of treatment effect engendered; if a complete or satisfactory response is determined 9420, then treatment is completed. For example, the assessment 9410 might include determination through microneurography, assessment of the carotid sinus reactivity (described above), heart rate variability, measurement of norepinephrine levels, etc. With a satisfactory autonomic response, further treatment might not ensue or depending on the degree of response, additional treatments of the nerves 9430 may ensue.

Figure 25 depicts a reconstruction of a patient from CT scan images showing the position of the kidneys 9520 looking through the skin of a patient 9500. The ribs 9510 partially cover the kidney but do reveal a window at the inferior pole 9530 of the kidney 9520. Analysis of
5 many of these reconstructions has lead to clinical paradigm in which the ribs 9510, pelvis 9420, and the vertebra 9440 are identified on a patient, the kidneys are identified via ultrasound and then renal arteries are identified via Doppler ultrasound.

As shown in figure 26a, once the ribs and vertebra are identified with
10 the Doppler ultrasound, an external energy source 9600 can be applied to the region. Specifically, focused ultrasound (HIFU or LIFU) can be applied to the region once these structures are identified and a lesion applied to the blood vessels (renal artery and renal nerve) 9620 leading to the kidney 9610. As described herein, the position of
15 the ultrasound transducer 9600 is optimized on the posterior of the patient as shown in Figure 26A. That is, with the vertebra, the ribs, and the iliac crest bordering the region where ultrasound is applied.

Based on the data above and specifically the CT scan anatomic information in figure 26A, figure 26B depicts a device and system 9650
20 designed for treatment of this region (blood vessels in the hilum of the kidney) in a patient. It contains a 0.5-3 Mhz ultrasound imaging transducer 9675 in its center and a cutout or attachment location of the ultrasound ceramic (e.g. PZT) for the diagnostic ultrasound placement. It also contains a movement mechanism 9660 to control the
25 therapeutic transducer 9670. The diagnostic ultrasound device 9675 is coupled to the therapeutic device in a well-defined, known relationship. The relationship can be defined through rigid or semi-rigid coupling or it can be defined by electrical coupling such as through infrared, optical-mechanical coupling and/or electro-
30 mechanical coupling. Along the edges of the outer rim of the device, smaller transducers 9670 can be placed which roughly identify tissues through which the ultrasound travels. For example, simple and inexpensive one or two-dimensional transducers might be used so as to

determine the tissues through which the ultrasound passes on its way to the target can be used for the targeting and safety. From a safety perspective, such data is important so that the ultrasound does not hit bone or bowel and that the transducer is properly placed to target the region around the renal blood vessels. Also included in the system is a cooling system to transfer heat from the transducer to fluid 9662 running through the system. Cooling via this mechanism allows for cooling of the ultrasound transducer as well as the skin beneath the system. A further feature of the system is a sensor mechanism 9665 which is coupled to the system 9650 and records movement of the system 9650 relative to a baseline or a coordinate nearby. In one embodiment, a magnetic sensor is utilized in which the sensor can determine the orientation of the system relative to a magnetic sensor on the system. The sensor 9665 is rigidly coupled to the movement mechanism 9660 and the imaging transducer 9675. In addition to magnetic, the sensor might be optoelectric, acoustic, or radiofrequency based.

Furthermore, the face 9672 of the transducer 9670 is shaped such that it fits within the bony region described and depicted in figure 26A. For example, the shape might be elliptical or aspheric or in some cases spherical. In addition, in some embodiments the ultrasound imaging engine might not be directly in the center of the device and in fact might be superior to the center and closer to the superior border of the face and closer to the ribs, wherein the renal artery is visualized better with the imaging probe 9675.

Given the clinical data as well as the devised technologies described above (e.g. Figure 26A-B), figure 27 illustrates the novel treatment plan 9700 to apply energy to the nerves around the renal artery with energy delivered from a position external to the patient.

In one embodiment, the patient is stabilized and/or positioned such that the renal artery and kidneys are optimally located 9710. Diagnostic ultrasound 9730 is applied to the region and optionally,

ultrasound is applied from a second direction 9715. The positioning and imaging maneuvers allow the establishment of the location of the renal artery, the hilum, and the vein 9720. A test dose of therapeutic energy 9740 can be applied to the renal hilum region. In some embodiments, temperature 9735 can be measured. This test dose can be considered a full dose if the treatment is in fact effective by one or more measures. These measures might be blood pressure 9770, decrease in sympathetic outflow (as measured by microneurography 9765), increase in parasympathetic outflow, change in the caliber of the blood vessel 9755 or a decrease in the number of spontaneous spikes in a microneurographic analysis in a peripheral nerve (e.g. peroneal nerve) 9765, or an MRI or CT scan which reveals a change in the nervous anatomy 9760. In some embodiments, indices within the kidney are utilized for feedback. For example, the resistive index,, a measure of the vasoconstriction in the kidney measured by doppler ultrasound is a useful index related to the renal nerve activity; for example, when there is greater autonomic activity, the resistive index increases, and vice versa.

Completion of the treatment 9745 might occur when the blood pressure reaches a target value 9770. In fact, this might never occur or it may occur only after several years and treatment. The blood pressure might continually be too high and multiple treatments may be applied over a period of years...the concept of dose fractionation.

Fractionation is a major advantage of applying energy from a region external to a region around the renal arteries in the patient as it is more convenient and less expensive when compared to invasive treatments such stimulator implantation and interventional procedures such as catheterization of the renal artery.

Another important component is the establishment of the location and position of the renal artery, renal vein, and hilum of the kidney 9720. As discussed above, the utilization of Doppler ultrasound signaling allows for the position of the nerves to be well approximated such that the ultrasound can be applied to the general

region of the nerves. The region of the nerves can be seen in Figures 29A-D . Figs 29A-C are sketches from actual histologic slices. The distances from the arterial wall can be seen at different locations and generally range from 0.3 mm to 10 mm. Nonetheless, these images are from actual renal arteries and nerves and are used so as to develop the treatment plan for the system. For example, once the arterial wall is localized 9730 using the Doppler or other ultrasound signal, a model of the position of the nerves can be established and the energy then targeted to that region to inhibit the activity of the nerves 9720. Notably, the distance of many of these nerves from the wall of the blood vessel indicate that a therapy which applies radiofrequency to the wall of the vessel from the inside of the vessel likely has great difficulty in reaching a majority of the nerves around the blood vessel wall.

Figure 29D depicts a schematic from a live human ultrasound. As can be seen, the ultrasound travels through skin, through the subcutaneous fat, through the muscle and at least partially through the kidney 8935 to reach the hilum 8941 of the kidney and the renal blood vessels 8937. This direction was optimized through clinical experimentation so as to not include structures which tend to scatter ultrasound such as bone and lung. Experimentation lead to the optimization of this position for the imaging and therapy of the renal nerves. The position of the ultrasound is between the palpable bony landmarks on the posterior of the patient as described above and below. The vertebrae are medial, the ribs superior and the iliac crest inferior. Importantly, the distance of these structures 8943 is approximately 8-12 cm and not prohibitive from a technical standpoint. These images from the ultrasound are therefore consistent with the results from the CT scans described above as well.

Figure 29E depicts the surface area 8760 available to an ultrasound transducer for two patients out of a clinical study. One patient was obese and the other thinner. Quantification of this surface area 8762 was obtained by the following methodology: 1) obtain CT scan; 2) mark

off boundary of organs such as the vertebrae, iliac crest, and ribs;
3) draw line from renal blood vessels to the point along the edge of
the bone; 4) draw perpendicular from edge bone to the surface of the
skin; 5) map the collection of points obtained along the border of the
5 bone. The surface area is the surface area between the points and the
maximum diameter is the greatest distance between the bony borders.
The collection of points obtained with this method delimits the area
on the posterior of the patient which is available to the ultrasound
transducer to either visualize or treat the region of the focal spot.
10 By studying a series of patients, the range of surface areas was
determined so as to assist in the design which will serve the majority
of patients. The transducers modeled in Figure 30 have surface areas
of approximately 11x8 cm or 88 cm² which is well within the surface
area shown in figure 29E 8762 which is representative of a patient
15 series. Further more the length, or distance, from the renal artery to
the skin was quantified in shortest ray 8764 and longest ray 8766.
Along with the the angular data presented above, these data enable
design of an appropriate transducer to achieve autonomic modulation
and control of blood pressure.
20 In a separate study, it was shown that these nerves could be inhibited
using ultrasound applied externally with the parameters and devices
described herein. Pathologic analysis revealed that the nerves around
the artery were completely inhibited and degenerated, confirming the
ability of the treatment plan to inhibit these nerves and ultimately
25 to treat diseases such as hypertension. Furthermore, utilizing these
parameters, did not cause any damage within the path of the ultrasound
through the kidney and to the renal hilum.
Importantly, it has also been discovered via clinical trials that when
ultrasound is used as the energy applied externally, that centering
30 the diagnostic ultrasound probe such that a cross section of the
kidney is visualized and the vessels are visualized, is an important
component of delivering the therapy to the correct position along the
blood vessels. One of the first steps in the algorithm 9700 is to

stabilize the patient in a patient stabilizer custom built to deliver energy to the region of the renal arteries. After stabilization of the patient, diagnostic ultrasound is applied to the region 9730 to establish the extent of the ribs, vertebrae, and pelvis location.

5 Palpation of the bony landmarks also allows for the demarcation of the treatment zone of interest. The external ultrasound system is then placed within these regions so as to avoid bone. Then, by ensuring that a portion of the external energy is delivered across the kidney (for example, using ultrasound for visualization), the possibility of

10 hitting bowel is all but eliminated. The ultrasound image in Figure 29D depicts a soft tissue path from outside the patient to the renal hilum inside the patient. The distance is approximately 8-16 cm. Once the patient is positioned, a cushion 9815 is placed under the patient. In one embodiment, the cushion 9815 is simply a way to prop up the

15 back of the patient. In another embodiment, the cushion 9815 is an expandable device in which expansion of the device is adjustable for the individual patient. The expandable component 9815 allows for compression of the retroperitoneum (where the kidney resides) to slow down or dampen movement of the kidney and maintain its position for

20 treatment with the energy source or ultrasound.

A test dose of energy 9740 can be given to the region of the kidney hilum or renal artery and temperature imaging 9735, constriction of blood vessels 9755, CT scans 9760, microneurography 9765 patch or electrode, and even blood pressure 9770. Thereafter, the treatment

25 can be completed 9745. Completion might occur minutes, hours, days, or years later depending on the parameter being measured.

Through experimentation, it has been determined that the region of the renal hilum and kidneys can be stabilized utilizing gravity with local application of force to the region of the abdomen below the ribs and

30 above the renal pelvis. For example, Figures 28A-C depict examples of patient positioners intended to treat the region of the renal blood vessels.

Figure 28A is one example of a patient positioned in which the ultrasound diagnostic and therapeutic 9820 is placed underneath the patient. The positioner 9810 is in the form of a tiltable bed. A patient elevator 9815 placed under the patient pushes the renal hilum
5 closer to the skin and can be pushed forward in this manner; as determined in clinical trials, the renal artery is approximately 2-3 cm more superficial in this type of arrangement with a range of approximately 7-15cm in the patients studied within the clinical trial. The weight of the patient allows for some stabilization of the
10 respiratory motion which would otherwise occur; the patient elevator can be localized to one side or another depending on the region to be treated.

Figure 28B depicts a more detailed configuration of the ultrasound imaging and therapy engine 9820 inset. A patient interface 9815 is
15 utilized to create a smooth transition for the ultrasound waves to travel through the skin and to the kidneys for treatment. The interface is adjustable such that it is customizable for each patient.

Figure 28C depicts another embodiment of a positioner device 9850, this time meant for the patient to be face down. In this embodiment,
20 the patient is positioned in the prone position lying over the patient elevator 9815. Again, through clinical experimentation, it was determined that the prone position with the positioner under the patient pushes the renal hilum posterior and stretches out the renal artery and vein allowing them to be more visible to ultrasound and
25 accessible to energy deposition in the region. The positioner underneath the patient might be an expandable bladder with one or more compartments which allows for adjustability in the amount of pressure applied to the underside of the patient. The positioner might also have a back side which is expandable 9825 and can push against the
30 posterior side of the patient toward the expandable front side of the positioner thereby compressing the stretched out renal blood vessels to allow for a more superficial and easier application of the energy device. These data can be seen in Figs 7G and 7H where the renal

artery is quite a bit closer to the skin (7-17cm down to 6-10cm). The position of the energy devices for the left side 9827 of the patient and right side 9828 of the patient are depicted in Figure 28C. The ribs 9829 delimit the upper region of the device placement and the iliac crest 9831 delimits the lower region of the device placement. The spinous processes 9832 delimit the medial edge of the region where the device can be placed and the region between 9828 is the location where the therapeutic transducer is placed.

The table elevation is on the front side of the patient, pushing upward toward the renal hilum and kidneys. The head of the table may be dropped or elevated so as to allow specific positioning positions. The elevated portion may contain an inflatable structure which controllably applies pressure to one side or another of the torso, head, or pelvis of the patient.

Figure 29A-C depicts the anatomical basis 9900 of the targeting approach described herein. These figures are derived directly from histologic slides. Nerves 9910 can be seen in a position around renal artery 9920. The range of radial distance from the artery is out to 2 mm and even out to 10 mm. Anatomic correlation with the modeling in Figure 16B reveals the feasibility of the targeting and validates the approach based on actual pathology; that is, the approach of applying therapy to the renal nerves by targeting the adventitia of the artery. This is important because the methodology used to target the nerves is one of detecting the Doppler signal from the artery and then targeting the vessel wall around the doppler signal. Nerves 9910 can be seen surrounding the renal artery 9920 which puts them squarely into the temperature field shown in 16B indicating the feasibility of the outlined targeting approach in Figure 27 and the lesion configuration in Figure 16A. Further experimentation (utilizing similar types of pathology as well as levels of norepinephrine in the kidney) reveals that the required dose of ultrasound to the region to affect changes in the nerves is on the order of 100 W/cm^2 for partial inhibition of the nerves and $1-2 \text{ kW/cm}^2$ for complete inhibition and necrosis of the

5 nerves. These doses or doses in between them might be chosen depending on the degree of nerve inhibition desired in the treatment plan. Importantly, it was further discovered through the experimentation that an acoustic plane through the blood vessels was adequate to partially or completely inhibit the nerves in the region. That is to say, that a plane through which the blood vessels travels perpendicularly is adequate to ablate the nerves around the artery as illustrated in Figure 16B. Until this experimentation, there had been no evidence that ultrasound would be able to inhibit nerves surrounding an artery by applying a plane of ultrasound through the blood vessel. Indeed, it was proven that a plane of ultrasound essentially could circumferentially inhibit the nerves around the blood vessel.

15 Figures 30A-I depict three dimensional simulations from a set of CT scans from the patient model shown in figure 26A. Numerical simulations were performed in three dimensions with actual human anatomy from the CT scans. The same CT scans utilized to produce figures 7E, 19, and 25 were utilized to simulate a theoretical treatment of the renal artery region considering the anatomy of a real patient. Utilizing the doses shown in the experimentation above (Figs 29A-D) combined with the human anatomy from the CT scans, it is shown with these simulations that the ability exists to apply therapeutic ultrasound to the renal hilum from a position outside the patient. In combination with figure 29, which as discussed, depicts the position of the nerves around the blood vessels as well as the position of the vessels in an ultrasound, figure 30A-I depicts the feasibility of an ultrasound transducer which is configured to apply the required energy to the region of the hilum of the kidney without damaging intervening structures. These simulations are in fact confirmation for the proof of concept for this therapy and incorporate the knowledge obtained from the pathology, human CT scans, human ultrasound scans, and the system designs presented previously above.

In one embodiment, Figure 30A, the maximum intensity is reached at the focus 10010 is approximately 186 W/cm^2 with a transducer 10000 design at 750 MHz; the transducer is approximately 11 x 8 cm with a central portion 10050 for an ultrasound imaging engine. The input wattage to the transducer is approximately 120W-150W depending on the specific patient anatomy.

Figures 30B and 30C depict the acoustic focus 10020, 10030 at a depth of approximately 9-11 cm and in two dimensions. Importantly, the region (tissues such as kidney, ureter, skin, muscle) proximal (10040 and 10041) to the focus 10020, 10030 do not have any significant acoustic power absorption indicating that the treatment can be applied safely to the renal artery region through these tissues as described above. Importantly, the intervening tissues are not injured in this simulation indicating the feasibility of this treatment paradigm.

Figures 30D-F depict a simulation with a transducer 10055 having a frequency of approximately 1 MHz. With this frequency, the focal spot 10070, 10040, 10050 size is a bit smaller (approximately 2 cm by 0.5 cm) and the maximum power higher at the focus, approximately 400 W/cm^2 than shown in Figures 30A-C. In the human simulation, this is close to an optimal response and dictates the design parameters for the externally placed devices. The transducer in this design is a rectangular type of design (spherical with the edges shaved off) so as to optimize the working space in between the posterior ribs of the patient and the superior portion of the iliac crest of the patient. Its size is approximately 11 cm x 8 cm which as described above and below is well within the space between the bony landmarks of the back of the patient.

Figures 30G-I depict a simulation with similar ultrasound variables as seen in Figs 30D-F. The difference is that the transducer 10090 was left as spherical with a central cutout rather than rectangular with a central cutout. The spherical transducer setup 10090 allows for a greater concentration of energy at the focus 1075 due to the increased

surface area of vibratory energy. Indeed, the maximum energy from this transducer (Fig 30G) is approximately 744 W/cm^2 whereas for the transducer in figure 30d, the maximum intensity is approximately 370 W/cm^2 . Figure 30H depicts one plane of the model and 30I another plane. Focus 10080, 10085 is depicted with intervening regions 10082 and 10083 free from acoustic power and heat generation, similar to Figure 30A-F.

These simulations confirm the feasibility of a therapeutic treatment of the renal sympathetic nerves from the outside without damage to intervening tissues or structures such as bone, bowel, and lung. Hypertension is one clinical application of this therapy. A transducer with an imaging unit within is utilized to apply focused ultrasound to a renal nerve surrounding a renal artery. Both the afferent nerves and efferent nerves are affected by this therapy.

Other transducer configurations are possible. Although a single therapeutic transducer is shown in Figure 30A-I, configurations such as phased array therapy transducers (more than one independently controlled therapeutic transducer) are possible. Such transducers allow more specific tailoring to the individual patient. For example, a larger transducer might be utilized with 2,3,4 or greater than 4 transducers. Individual transducers might be turned on or off depending on the patients anatomy. For example, a transducer which would cover a rib in an individual patient might be turned off during the therapy.

Although the central space is shown in the center of the transducer in figures 30A-I, the imaging transducer might be placed anywhere within the field as long as its position is well known relative to the therapy transducers. For example, insofar as the transducer for therapy is coupled to the imaging transducer spatially in three dimensional space and this relationship is always known, the imaging transducer can be in any orientation relative to the therapeutic transducer.

Claims

1. A method of treatment, comprising:
placing an energy source outside a patient;
operating the energy source so that an energy delivery path of the energy source is aimed towards a nerve inside the patient, wherein the nerve is a part of an autonomic nervous system; and
using the energy source to deliver treatment energy from outside the patient to the nerve located inside the patient to treat the nerve.
2. The method of claim 1, wherein the treatment energy comprises focused energy.
3. The method of claim 1, wherein the treatment energy comprises non-focused energy.
4. The method of claim 1, wherein the treatment energy comprises HIFU energy.
5. The method of claim 1, wherein the treatment energy comprises LIFU energy.
6. The method of claim 1, wherein the treatment energy is delivered to the nerve to achieve partial ablation of the nerve.
7. The method of claim 1, wherein the treatment energy is delivered to the nerve to achieve complete ablation of the nerve.
8. The method of claim 1, wherein the treatment energy is delivered to achieve paralysis of the nerve.
9. The method of claim 1, wherein the nerve leads to a kidney.

10. The method of claim 9, wherein the nerve comprises a renal nerve.
11. The method of claim 9, wherein the nerve comprises a sympathetic nerve connected to the kidney.
12. The method of claim 9, wherein the nerve comprises an afferent nerve connected to the kidney.
13. The method of claim 9, wherein the nerve comprises a renal sympathetic nerve at a renal pedicle.
14. The method of claim 1, wherein the nerve comprises a nerve trunk adjacent to a vertebra.
15. The method of claim 1, wherein the nerve comprises a ganglion adjacent to a vertebra.
16. The method of claim 1, wherein the nerve comprises a dorsal root nerve.
17. The method of claim 1, wherein the nerve leads to an adrenal gland.
18. The method of claim 1, wherein the nerve comprises a motor nerve.
19. The method of claim 1, wherein the nerve is next to a kidney.
20. The method of claim 1, wherein the nerve is behind an eye.
21. The method of claim 1, wherein the nerve comprises a celiac plexus.
22. The method of claim 1, wherein the nerve is within or around a vertebral column.

23. The method of claim 1, wherein the nerve extends to a facet joint

24. The method of claim 1, wherein the nerve comprises a celiac ganglion.

25. The method of claim 1, wherein the act of operating the energy source comprises positioning the energy source.

26. The method of claim 1, wherein the energy source comprises an ultrasound energy source.

27. The method of claim 26, wherein the ultrasound energy source is used to deliver the treatment energy to the nerve from multiple directions outside the patient.

28. The method of claim 1, wherein the treatment energy is delivered to modulate the nerve without damaging the nerve.

29. The method of claim 1, further comprising determining a position of a renal vessel using an imaging device located outside the patient.

30. The method of claim 29, wherein the position of the renal vessel is used to determine a position of the nerve.

31. The method of claim 29, wherein the imaging device comprises a CT device, an MRI device, a thermography device, an infrared imaging device, an optical coherence tomography device, a photoacoustic imaging device, a PET imaging device, a SPECT imaging device, or an ultrasound device.

32. The method of claim 1, further comprising determining a position of the nerve inside the patient.

33. The method of claim 32, wherein the act of determining the position of the nerve inside the patient comprises determining a position of a renal vessel to target the nerve that surrounds the renal vessel.

34. The method of claim 33, wherein the renal vessel comprises a renal artery.

35. The method of claim 32, wherein the act of determining the position of the nerve inside the patient comprises using a Doppler triangulation technique.

38. The method of claim 32, wherein the imaging device comprises a MRI device.

39. The method of claim 32, wherein the imaging device comprises a CT device.

40. The method of claim 32, wherein the treatment energy comprises HIFU energy, and the imaging device comprises a MRI device.

41. The method of claim 32, wherein the treatment energy comprises HIFU energy, and the imaging device comprises an ultrasound device.

42. The method of claim 32, wherein the nerve leads to a kidney, and the imaging device comprises a MRI device.

43. The method of claim 32, wherein the nerve leads to a kidney, and the imaging device comprises an ultrasound device.

44. The method of claim 32, wherein the nerve leads to a kidney, and the imaging device is used to obtain a doppler signal.

45. The method of claim 1, wherein the treatment energy is delivered to a kidney to decrease a sympathetic stimulus to the kidney, decrease an afferent signal from the kidney to an autonomic nervous system, or both.

46. The method of claim 1, further comprising delivering testing energy to the patient to determine if there is a reaction resulted therefrom, wherein the testing energy is delivered before the treatment energy is delivered from the energy source.

47. The method of claim 46, wherein the testing energy comprises heat or vibratory energy, and the method further comprises performing a test to detect sympathetic nerve activity.

48. The method of claim 46, wherein the testing energy comprises a stimulus applied to a skin, and the method further comprises detecting an output from the patient.

49. The method of claim 48, wherein the output comprises a heart rate.

50. The method of claim 46, wherein the test energy is delivered to stimulate a baroreceptor complex, and wherein the method further comprises:

applying pressure to a carotid artery; and
determining whether a blood pressure decreases after application of the pressure to the carotid artery.

51. The method of claim 50, wherein the test energy is delivered using an ultrasound device that is placed outside the patient.

52. The method of claim 50, wherein the treatment energy from the energy source is delivered if the blood pressure decreases or if the

blood pressure decreases at a rate that is above a prescribed threshold.

53. The method of claim 1, wherein the treatment energy is delivered to treat hypertension.

54. The method of claim 1, wherein the treatment energy is delivered to treat glaucoma.

55. The method of claim 1, wherein the energy source is operated so that the energy source aims at a direction that aligns with a vessel that is next to the nerve.

56. The method of claim 1, further comprising tracking a movement of a treatment region containing the nerve.

57. The method of claim 1, wherein the energy delivery path of the energy source is aimed towards the nerve by using a position of a blood vessel that is surrounded by the nerve.

58. The method of claim 1, further comprising:
delivering a device inside the patient; and
using the device to determine a position of the nerve inside the patient;

wherein the energy source is operated based at least in part on the determined position so that the energy delivery path is aimed towards the nerve.

59. The method of claim 58, wherein the device is placed inside a vessel that is surrounded by the nerve, and the position of the nerve is determined indirectly by determining a position of the vessel.

60. A system for treatment, comprising:
an energy source for placement outside a patient;

wherein the energy source is configured to aim an energy delivery path towards a nerve that is a part of an autonomic nervous system inside the patient; and

wherein the energy source is configured to deliver treatment energy from outside the patient to the nerve located inside the patient to treat the nerve.

61. The system of claim 60, wherein the energy source is configured to provide focused energy.

62. The system of claim 60, wherein the energy source is configured to provide non-focused energy.

63. The system of claim 60, wherein the energy source is configured to provide HIFU energy.

64. The system of claim 60, wherein the energy source is configured to provide LIFU energy.

65. The system of claim 60, wherein the energy source is configured to provide the treatment energy to achieve partial ablation of the nerve.

66. The system of claim 60, wherein the energy source is configured to deliver the treatment energy to achieve complete ablation of the nerve.

67. The system of claim 60, wherein the energy source is configured to deliver the treatment energy to achieve paralysis of the nerve.

68. The system of claim 60, wherein the energy source comprises an ultrasound energy source.

69. The system of claim 68, wherein the ultrasound energy source is configured to deliver the treatment energy to the nerve from multiple directions outside the patient while the ultrasound energy source is stationary relative to the patient.

70. The system of claim 60, wherein the energy source is configured to deliver the treatment energy to modulate the nerve without damaging tissues that are within a path of the treatment energy to the nerve.

71. The system of claim 60, wherein the nerve comprises a renal nerve, and the system further comprises a processor located outside the patient, wherein the processor is configured for:

receiving an input related to a position of a renal artery;
determining an output related to a position of the renal nerve based on a model that associates artery position with nerve position;
and

providing the output to a positioning system for the energy source so that the positioning system can cause the energy source to deliver the treatment energy from the outside of the patient to the renal nerve to treat the renal nerve.

72. The system of claim 60, further comprising a processor for determining a position of a renal vessel located outside the patient.

73. The system of claim 72, further comprising an imaging device for providing an image signal, wherein the processor is configured to determine the position based on the image signal.

74. The system of claim 73, wherein the imaging device comprises a CT device, a MRI device, a thermography device, an infrared imaging device, an optical coherence tomography device, a photoacoustic imaging device, a PET imaging device, a SPECT imaging device, or an ultrasound device.

75. The system of claim 72, wherein the position of the renal vessel is used during the treatment energy delivery to target the nerve that surrounds the renal vessel.

76. The system of claim 72, wherein the position is determined using a Doppler triangulation technique.

77. The system of claim 72, wherein the renal vessel comprises a renal artery.

78. The system of claim 60, wherein treatment energy is delivered to a kidney to decrease a sympathetic stimulus to the kidney, decrease an afferent signal from the kidney to an autonomic nervous system, or both.

79. The system of claim 60, wherein the energy source is also configured to deliver testing energy to the patient to determine if there is a reaction resulted therefrom.

80. The system of claim 60, wherein the energy source is configured to deliver the treatment energy to treat hypertension.

81. The system of claim 60, wherein the energy source is configured to deliver the treatment energy to treat glaucoma.

82. The system of claim 60, wherein the energy source has an orientation so that the energy source aims at a direction that aligns with a vessel that is next to the nerve.

83. The system of claim 60, wherein the energy source is configured to track a movement of the nerve.

84. The system of claim 83, wherein the energy source is configured to track the movement of the nerve by tracking a movement of a blood vessel next to the nerve.

85. The system of claim 60, wherein the energy source is configured to aim at the nerve by aiming at a vessel that is surrounded by the nerve.

86. The system of claim 60, further comprising:
a device for placement inside the patient; and
a processor for determining a position using the device;
wherein the energy source is configured to aim the energy delivery path towards the nerve inside the patient based at least in part on the determined position.

87. The system of claim 86, wherein the device is sized for insertion into a vessel that is surrounded by the nerve.

88. A system to deliver energy from a position outside a skin of a patient to a nerve surrounding a blood vessel inside the patient, comprising:

a processor configured to receive image signal, and determine a three dimensional coordinate of a blood vessel based on the image signal; and

an energy source configured to deliver energy from the position outside the skin of the patient to the nerve surrounding the blood vessel;

wherein the processor is also configured to control the energy source based on the determined coordinate.

89. The system of claim 88, further comprising an imaging device for providing the image signal.

90. The system of claim 89, wherein the imaging device comprises a MRI device.

91. The system of claim 89, wherein the imaging device comprises an ultrasound device.

92. The system of claim 88, wherein the energy comprises focused energy.

93. The system of claim 88, wherein the energy comprises focused ultrasound.

94. The system of claim 88, wherein the energy source comprises an ultrasound array that is aligned with the vessel.

95. The system of claim 88, further comprising an imaging device for providing a B-mode ultrasound for imaging the blood vessel.

96. A system to deliver energy from a position outside a skin of a patient to a nerve surrounding a blood vessel comprising:

a fiducial for placement inside the blood vessel;

a detection device to detect the fiducial inside the blood vessel;

a processor configured to determine a three dimensional coordinate of the detected fiducial; and

an energy source configured to transmit energy through the skin and to focus the energy at the region of the blood vessel;

wherein the processor is configured to operate the energy source based on the determined three dimensional coordinate of the fiducial, and information regarding the blood vessel.

97. The system of claim 96, wherein the energy source comprises an ultrasound device, and wherein the blood vessel is a renal artery.

98. The system of claim 96, further comprising an ultrasound imaging system.

99. The system of claim 96, wherein the fiducial is placed inside the blood vessel and is attached to an intravascular catheter.

100. The system of claim 96, wherein the fiducial is a passive fiducial that is configured to respond to an external signal.

101. The system of claim 96, wherein the fiducial is an active fiducial, transmitting its position to the detection device.

102. A method to treat hypertension in a patient comprising:
obtaining an imaging signal from a blood vessel in the patient;
planning a delivery of energy to a wall of the blood vessel; and
delivering energy from outside a skin of the patient to an autonomic nerve surrounding the blood vessel.

103. The method of claim 102, further comprising selectively modulating an afferent nerve within a sympathetic nerve bundle.

104. The method of claim 102, further comprising utilizing microneurography after the delivery of the energy to determine an effect of the energy delivery on a sympathetic nervous system.

105. The method of claim 102, wherein the blood vessel extends to or from a kidney, and the method further comprises locating the blood vessel with doppler ultrasound.

106. A system to modulate an autonomic nerve in a patient utilizing transcutaneous energy delivery, the system comprising:
a processor comprising;

an input for receiving information regarding energy and power to be delivered to a treatment region containing the nerve; and

an output for outputting a signal;

wherein the processor is configured to determine a position of a reference target from outside the patient to localize the nerve relative to the reference target;

a therapeutic energy device comprising:

- a transducer for delivering energy from outside the patient;
- a controller to control an aiming of the transducer based at least in part on the signal from the processor; and
- an imaging system coupled to the processor or the therapeutic energy device.

107. The system of claim 106, wherein the processor is configured to determine the position during an operation of the therapeutic energy device.

108. The system of claim 106, further comprising a patient interface configured to position the therapeutic device so that the transducer is aimed toward a blood vessel connected to a kidney from a position between ribs superiorly, a iliac crest inferiorly, and a vertebral column medially.

109. The system of claim 106, wherein the therapeutic energy device is configured to deliver focused ultrasound.

110. The system of claim 106, wherein the reference target is at least a portion of a blood vessel traveling to or from a kidney, and the nerve is a renal nerve.

111. The system of claim 110, wherein the transducer is configured to focus energy at a distance from 6 cm to 18 cm.

112. The system of claim 106, wherein the transducer is configured to deliver the energy in a form of focused ultrasound to a renal blood vessel at an angle ranging between about -10 degrees and about -48 degrees relative to a horizontal line connecting transverse processes of a spinal column.

113. The system of claim 106, wherein the energy from the therapeutic energy device ranges between 100 W/cm² and 2500 W/cm².

114. The system of claim 106, wherein the reference target is an indwelling vascular catheter.

115. The system of claim 106, wherein the imaging system is a magnetic resonance imaging system and the therapeutic energy device is an ultrasound device.

116. The system of claim 106, wherein the imaging system is an ultrasound imaging system.

117. The system of claim 106, wherein the processor is a part of the therapeutic energy device.

118. The system of claim 106, wherein the processor is a part of the imaging system.

119. A method to deliver energy from a position outside the skin of a patient to a nerve surrounding a blood vessel, comprising:

placing a device inferior to ribs, superior to an iliac crest, and lateral to a spine;

using the device to maintain an energy delivery system at a desired position relative to the patient so that the energy delivery system can deliver energy through the skin without traversing bone.

120. The method of claim 119, wherein the energy delivery system comprises a focused ultrasound delivery system.

121. A device for use in a system to deliver focused ultrasound energy from a position outside a skin of a patient to a nerve surrounding a blood vessel, comprising:

a positioning device configured to maintain an energy delivery system at a desired position relative to the patient so that the energy delivery system can deliver energy through the skin without traversing bone;

wherein the positioning device is configured to be placed inferior to ribs, superior to an iliac crest, and lateral to a spine.

122. The device of claim 121, wherein the energy delivery system comprises a focused ultrasound delivery system.

123. The device of claim 122, wherein the positioning device is configured to maintain an angle of the focused ultrasound delivery system such that bony structures are not include in an ultrasound field .

124. A system for treatment, comprising:

a treatment device configured to deliver energy from outside a patient to a nerve inside the patient;

a catheter configured for placement inside a vessel surrounded by the nerve, the catheter configured to transmit a signal; and

a processor configured to receive the signal and determine a reference position in the vessel;

wherein the treatment device is configured deliver the energy to the nerve based on the determined reference position.

125. The system of claim 124, wherein the treatment device comprises an ultrasound device.

126. A method of inhibiting the function of a nerve traveling with an artery comprising:

 providing an external imaging modality to determine the location of the artery of a patient;

 placing the artery in a first three dimensional coordinate reference based on the imaging;

 placing or associating a therapeutic energy generation source in the first three dimensional coordinate reference frame;

 modeling the delivery of energy to the adventitial region of the artery or a region adjacent to the artery where a nerve travels;

 delivering therapeutic energy from the therapeutic energy source, from at least two different angles, through the skin of a patient, to intersect at the artery or the region adjacent to the artery;

 and, at least partially inhibiting the function of the nerve traveling with the artery.

127. The method of claim 126, wherein the imaging modality is one of: ultrasound, MRI, and CT.

128. The method of claim 126, wherein the therapeutic energy is ultrasound.

129. The method of claim 126, wherein the artery is a renal artery.

130. The method of claim 126, wherein placing the artery in a three dimensional reference frame comprises locating the artery using a doppler ultrasound signal.

131. The method of claim 126, further comprising: utilizing a fiducial wherein the fiducial is placed internal to the patient.

132. The method of claim 131, wherein said fiducial is temporarily placed in a position internal to the patient.

133. The method of claim 131, wherein said fiducial is a catheter placed in the artery of the patient.

134. The method of claim 133, wherein said catheter is detectable using a radiofrequency signal and said imaging modality is ultrasound.

135. The method of claim 126, wherein the therapeutic energy from the energy source is delivered in a distribution along the length of the artery.

136. The method of claim 126, wherein the therapeutic energy is ionizing radiation.

137. A system to inhibit the function of a nerve traveling with a renal artery comprising:

 a detector to determine the location of the renal artery and renal nerve from a position external to a patient;

 an ultrasound component to deliver therapeutic energy through the skin from at least two directions to the nerve surrounding the renal artery;

 a modeling algorithm comprising an input and an output, said input to the modeling algorithm comprising a three dimensional coordinate space containing a therapeutic energy source and the position of the renal artery in the three dimensional coordinate space; and,

 said output from the modeling algorithm comprising: the direction and energy level of the ultrasound component;

 a fiducial, locatable from a position outside a patient, adapted to be temporarily placed in the artery of the patient and communicate with the detector to determine the location of the renal artery in a three dimensional reference frame, the information regarding the location transmittable as the input to the model.

138. The system of claim 137, wherein the fiducial is a passive reflector of ultrasound.

139. The system of claim 137, wherein the fiducial generates radiofrequency energy.

140. The system of claim 137, wherein the fiducial is activated to transmit energy based on a signal from an ultrasound or magnetic field generator.

141. The system of claim 137, wherein the output from the model instructs the ultrasound component to deliver a lesion on the artery in which the major axis of the lesion is longitudinal along the length of the artery.

142. The system of claim 141, wherein the output from the model instructs the ultrasound component to deliver multiple lesions around an artery simultaneously.

143. The system of claim 137, wherein the output from the model instructs the ultrasound component to deliver a circumferential lesion around the artery.

144. The system of claim 141, wherein the lesion is placed around the renal artery just proximal to the bifurcation of the artery in the hilum of the kidney.

145. A method to stimulate or inhibit the function of a nerve traveling to or from the kidney comprising:

- a. Identifying an acoustic window at the posterior region of a patient in which the renal arteries can be visualized;
- b. transmitting a first energy through the skin of a patient from the posterior region of the patient;
- c. imaging an arterial region using the first transmitted energy;

d. applying a second transmitted energy to the arterial adventitia by coupling the imaging and the second transmitted energy.

146. The method of claim 145, further comprising: tracking the image created by the first transmitted energy.

147. A method to locate the position of a blood vessel in the body of a patient comprising:

applying a first wave of ultrasound, from a first direction, to a region of a blood vessel from outside of the patient and detecting its return signal;

comparing the applied first wave and its return signal;

simultaneously, or sequentially, applying a second wave of ultrasound from a second direction to the blood vessel and detecting a its return signal;

integrating the return signals from the first wave and the return signals from the second wave to determine the position, in a three dimensional coordinate reference, of the blood vessel.

148. The method of claim 147, further comprising the step of instructing a therapeutic ultrasound transducer to apply energy to the position of the blood vessel.

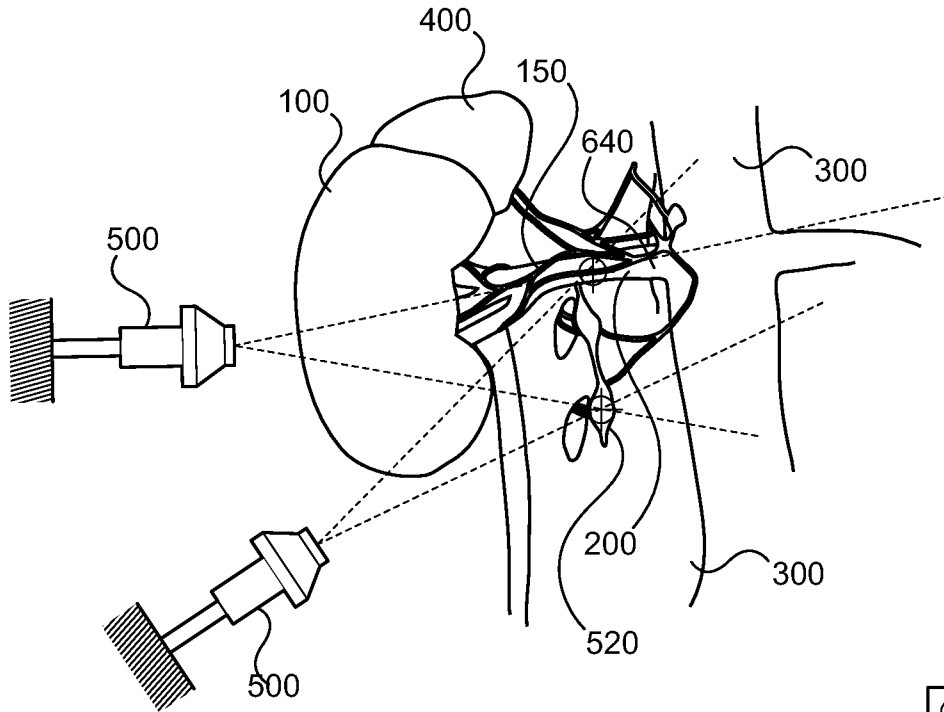

FIG. 1A

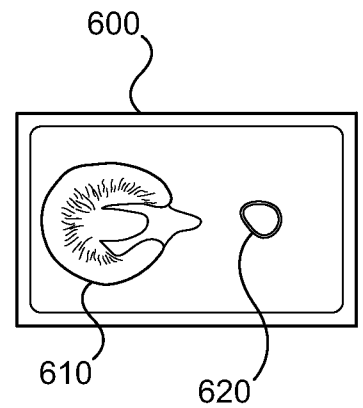

FIG. 1C

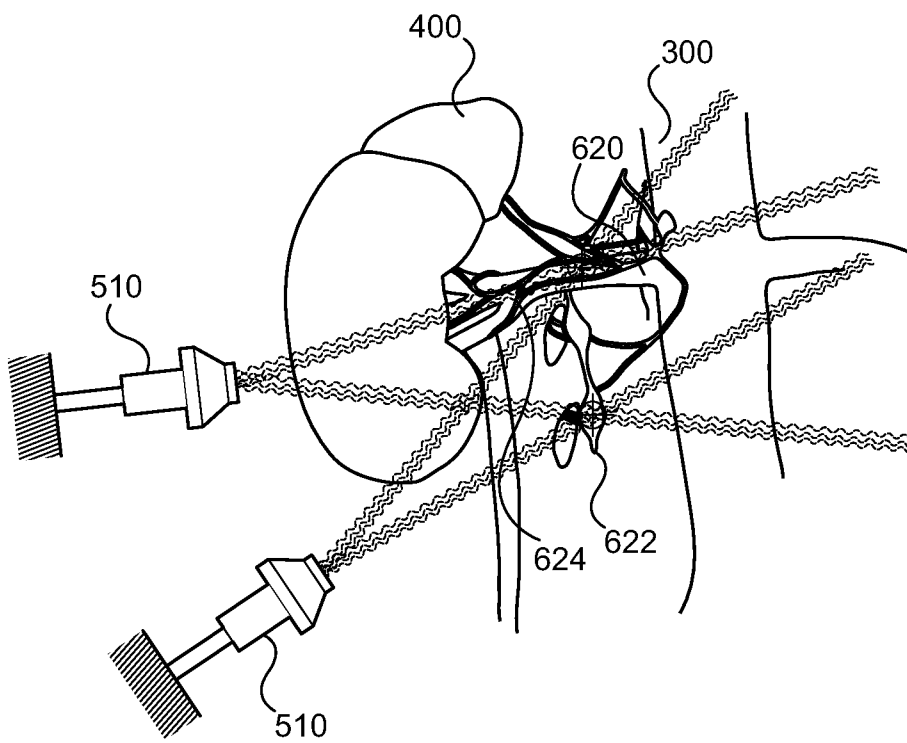

FIG. 1B

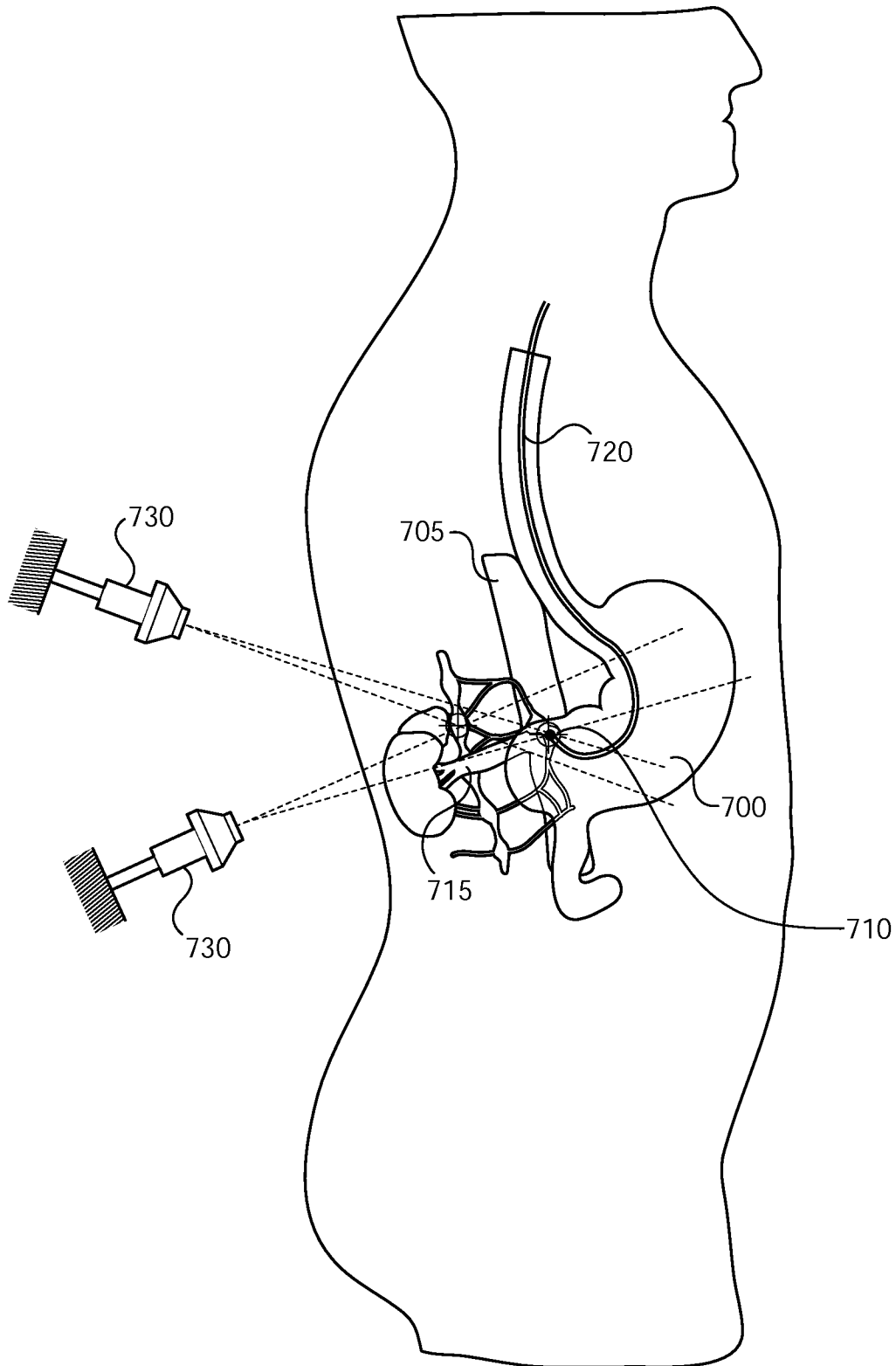

FIG. 2

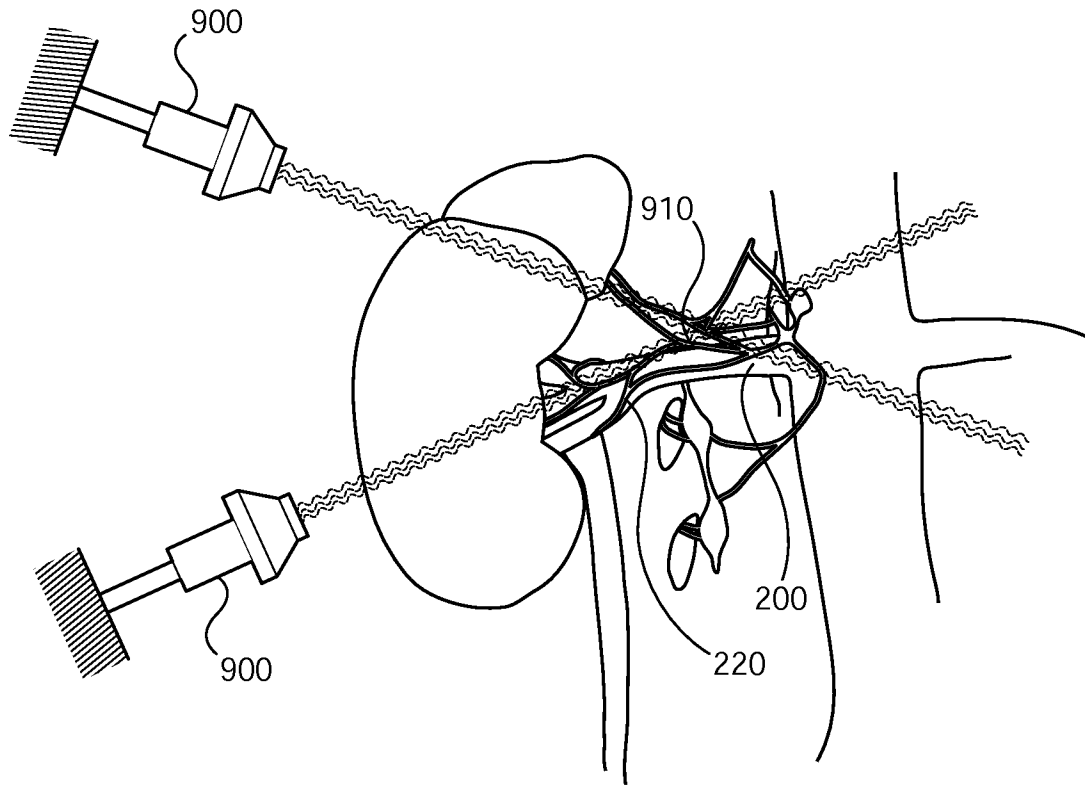

FIG. 3A

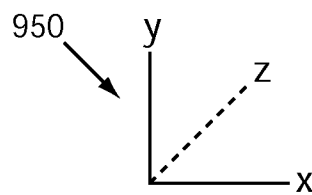

FIG. 3B

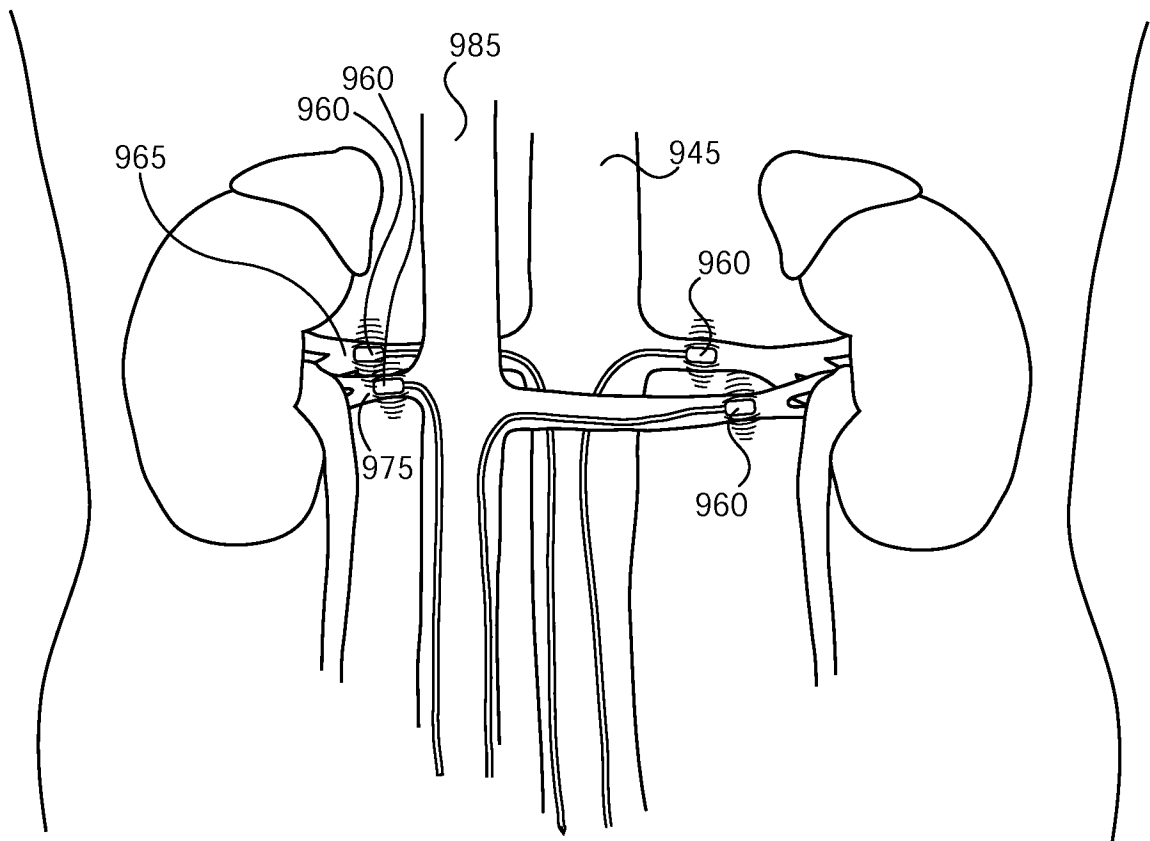

FIG. 3C

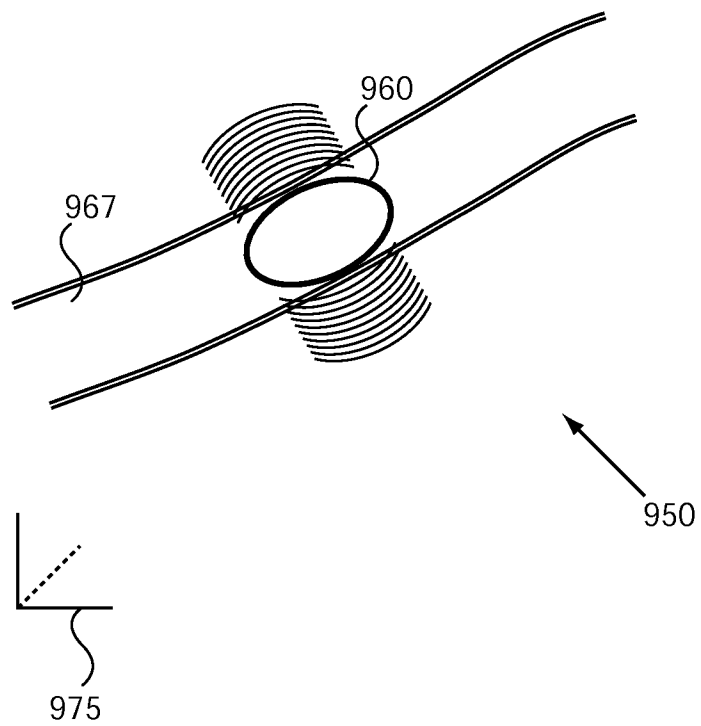

FIG. 3D

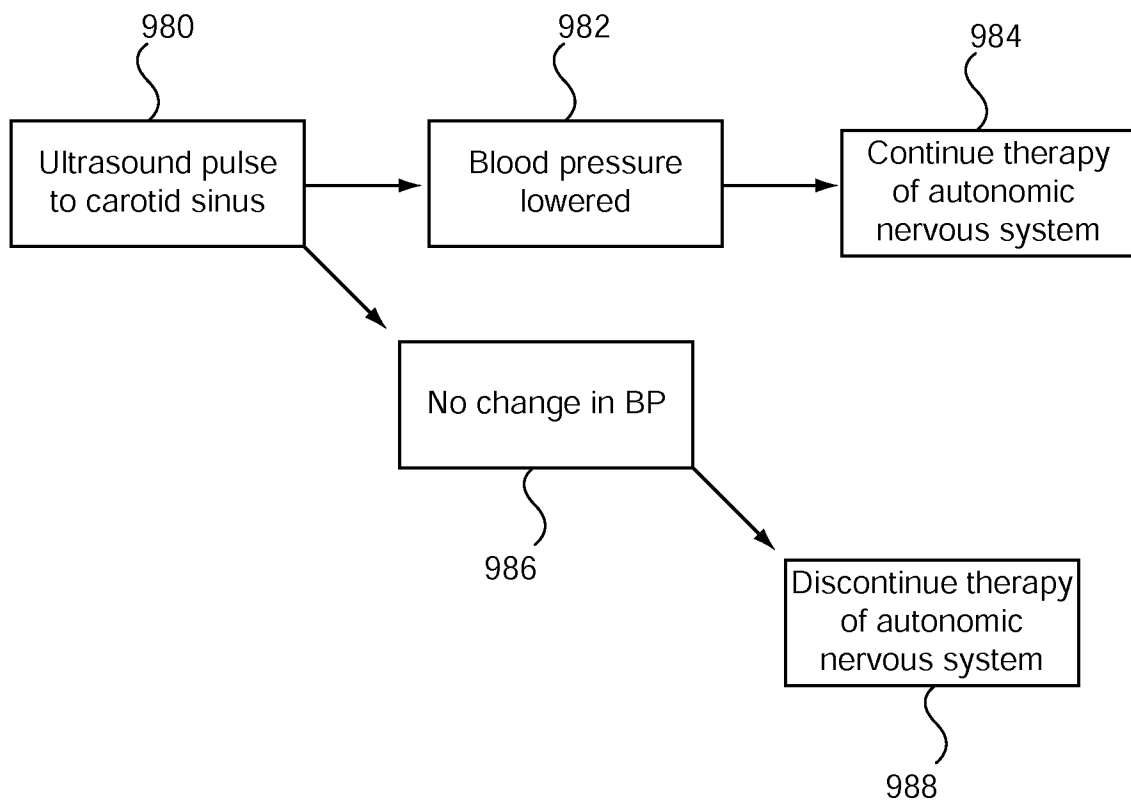

FIG. 3E

7/51

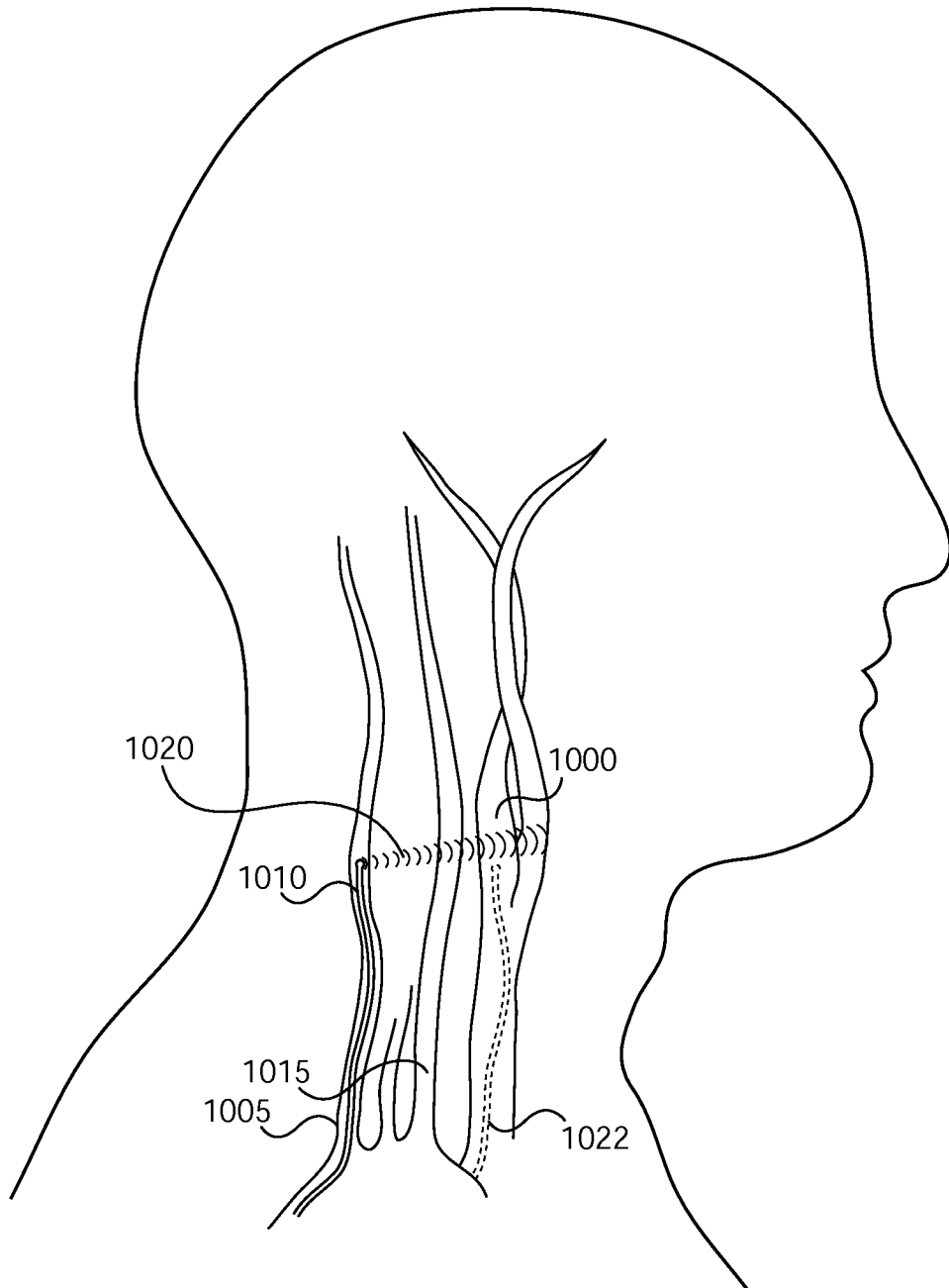

FIG. 4A

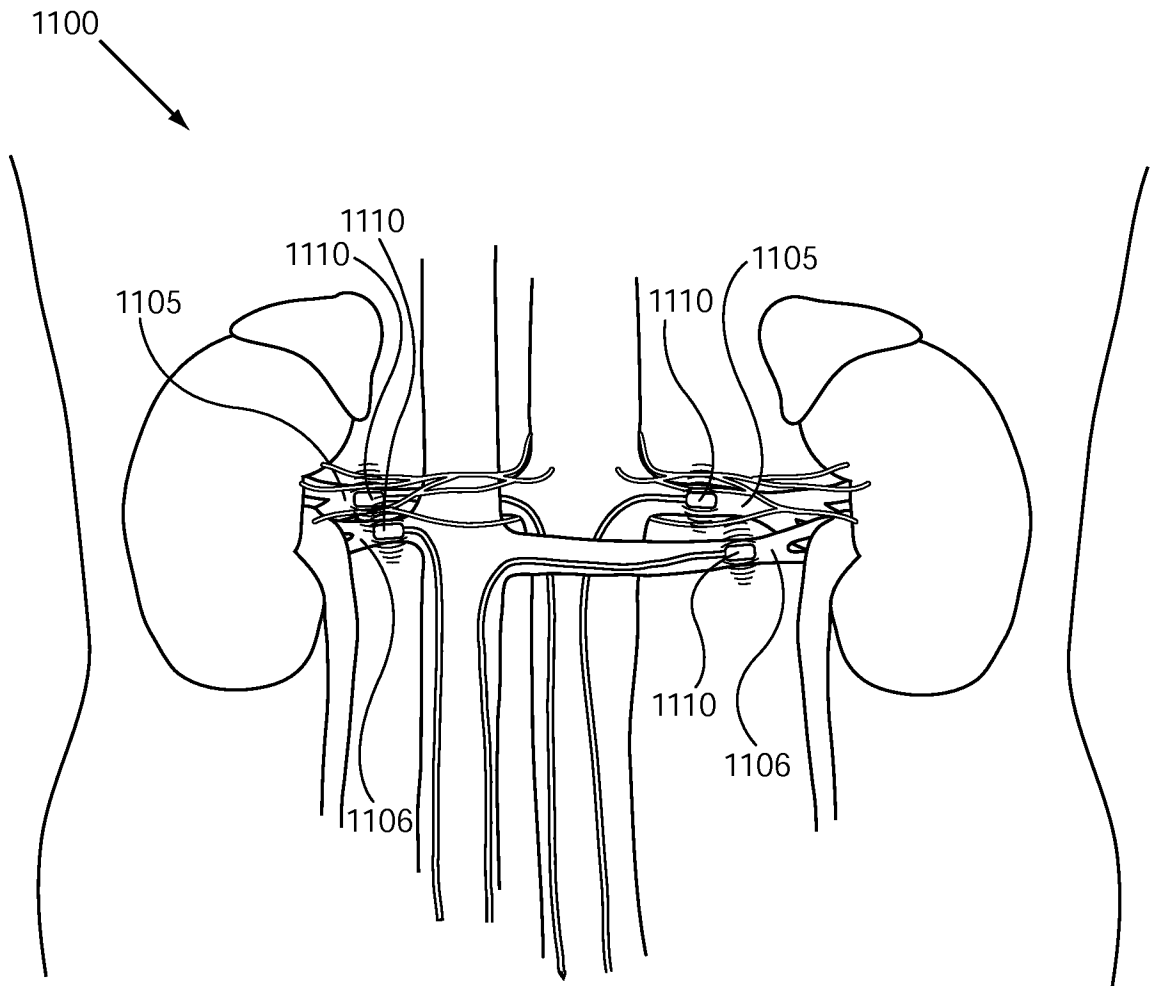

FIG. 4B

9/51

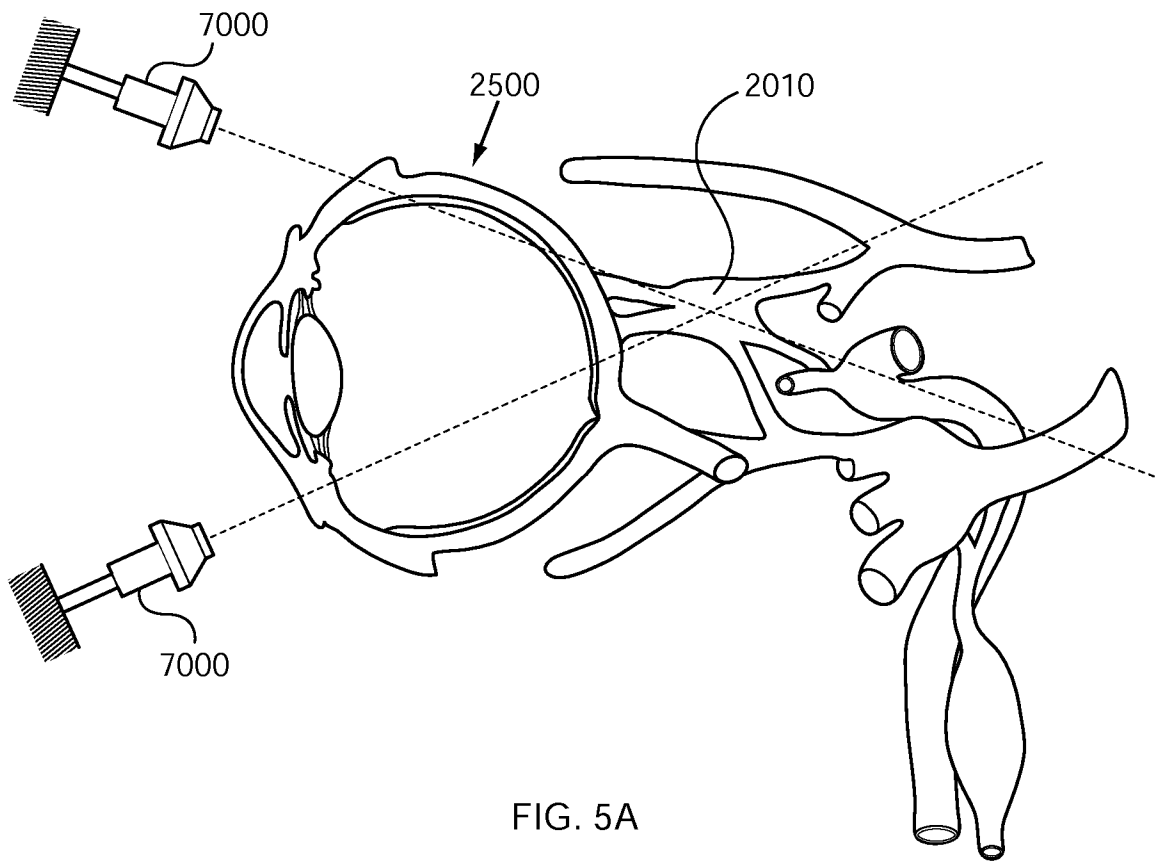

FIG. 5A

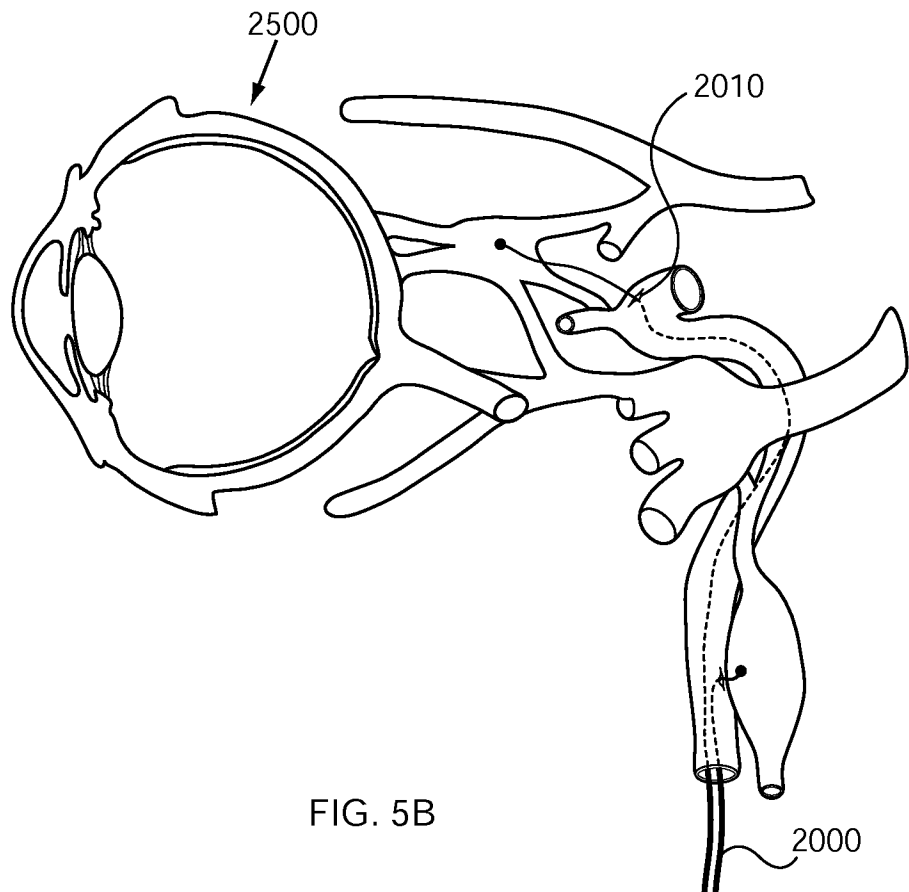

FIG. 5B

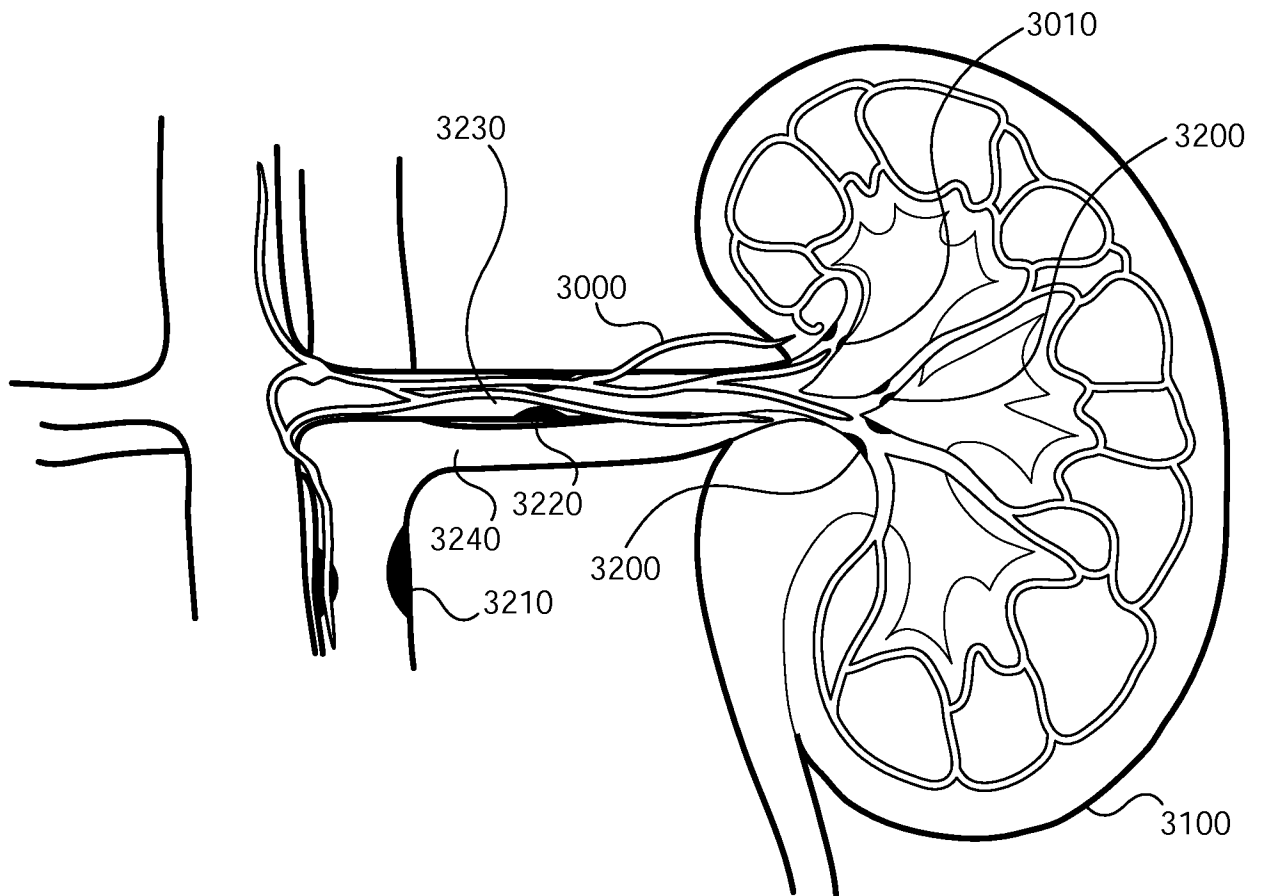

FIG. 6

11/51

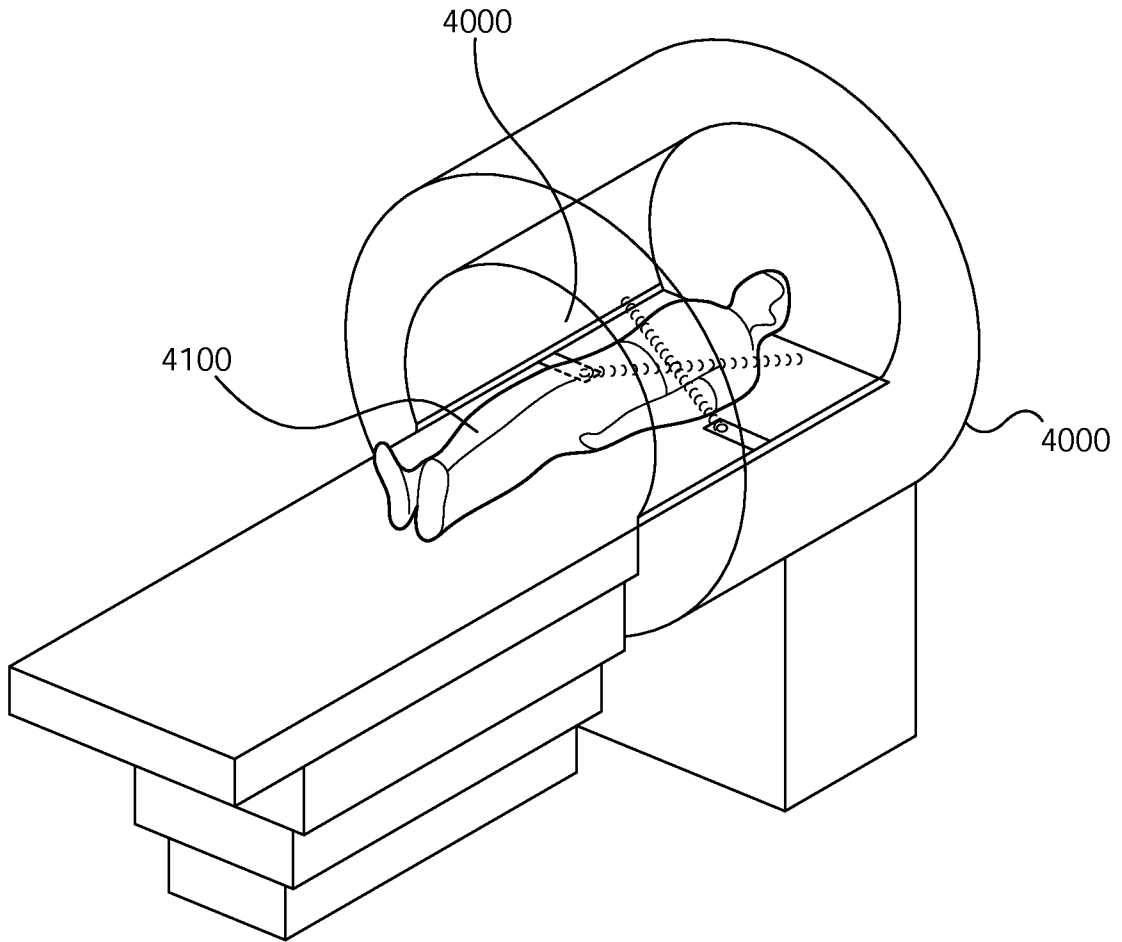

FIG. 7A

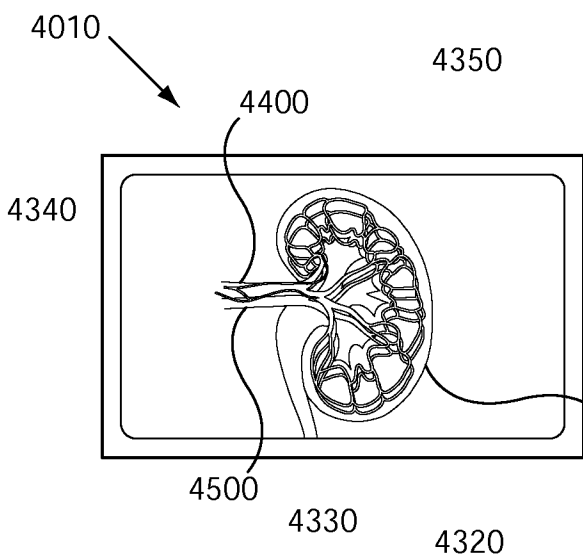

FIG. 7B

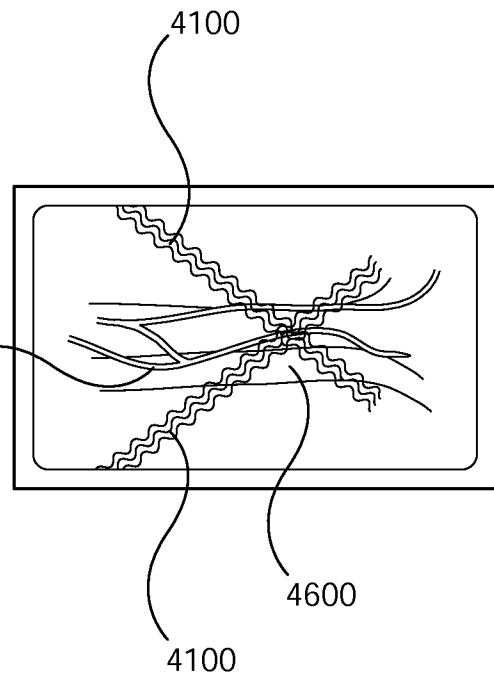

FIG. 7C

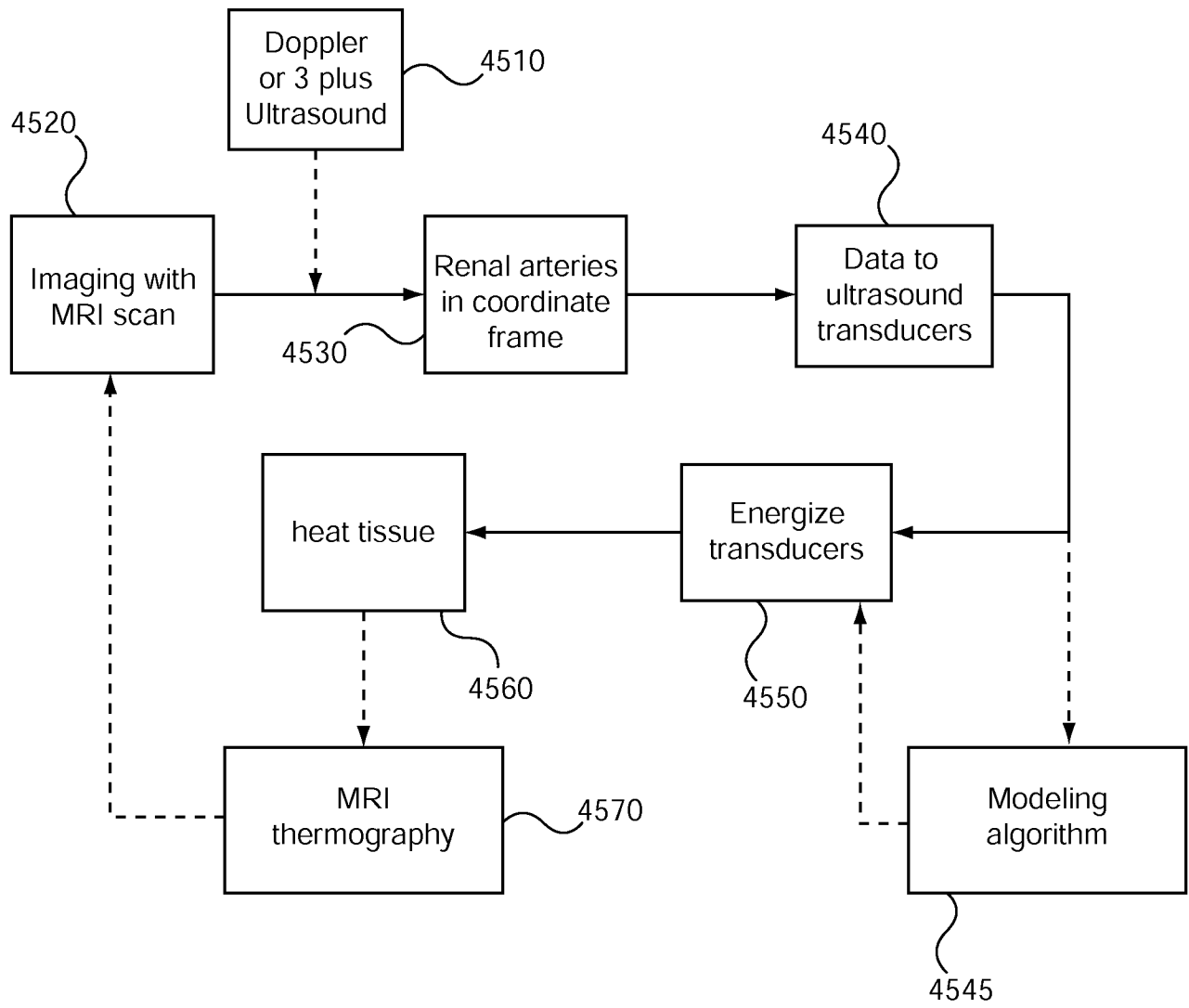

FIG. 7D

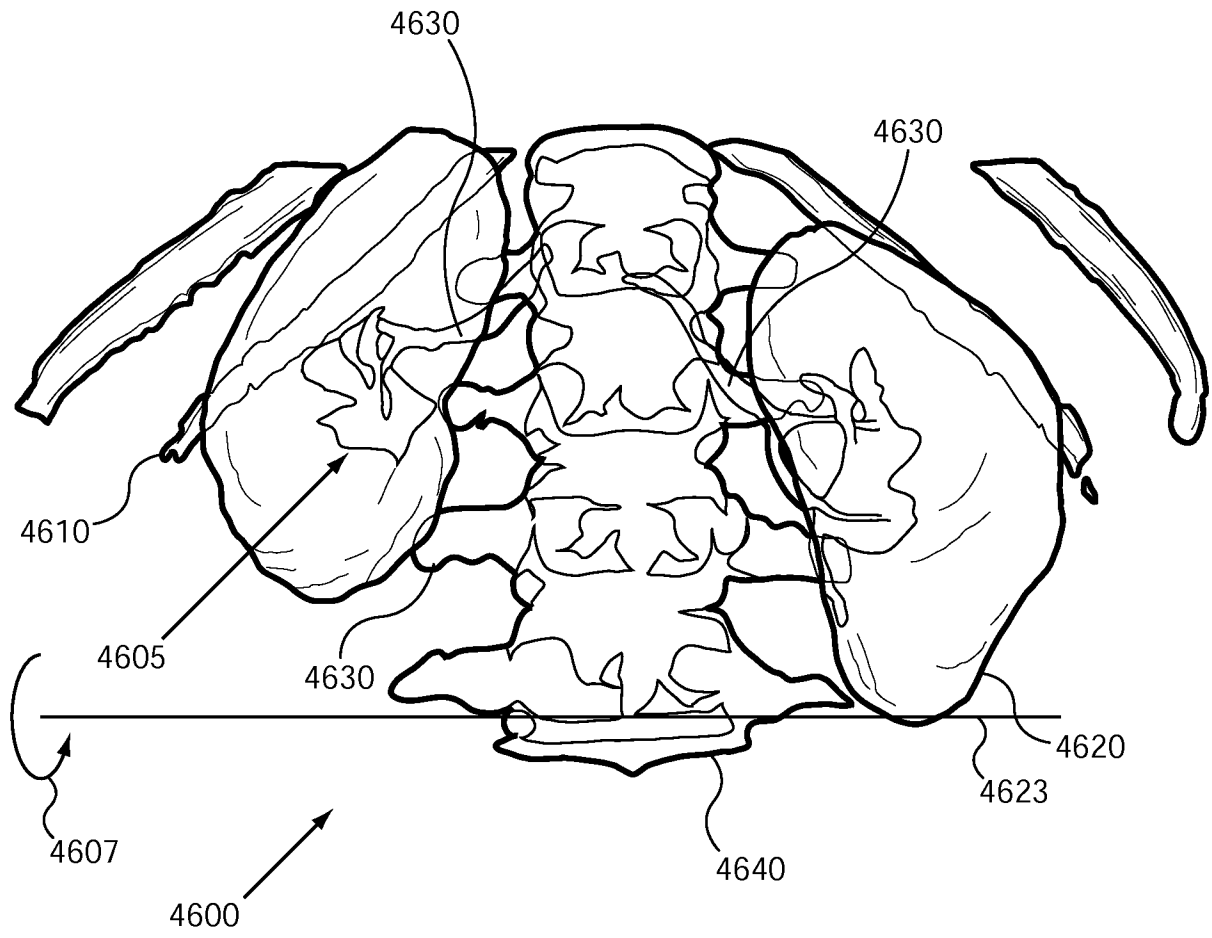

FIG. 7E

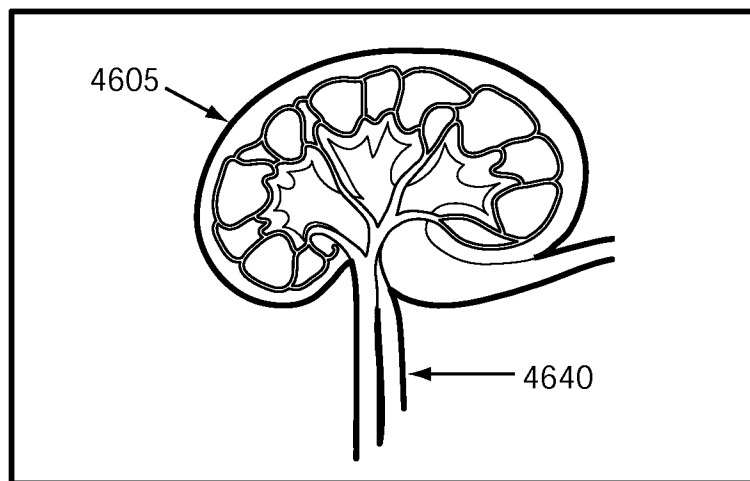

FIG. 7F

4730

Parameters - Standard Position



	STRUCTURE	DISTANCE
4635	Renal artery	7.0 - 17 cm
4640	Kidney hilum	4 cm - 8 cm
4637 (4607)	Angle of approach	-10°(-48°)

4700

4710

4720

FIG. 7G

Prone Position	
STRUCTURE	DISTANCE
4770  Renal artery	6.0 - 10.0 cm
4780  Kidney hilum	4.0 cm - 8.0 cm
4790  Angle of approach	5 - 20°

4750 

4740 

4760 

FIG. 7H

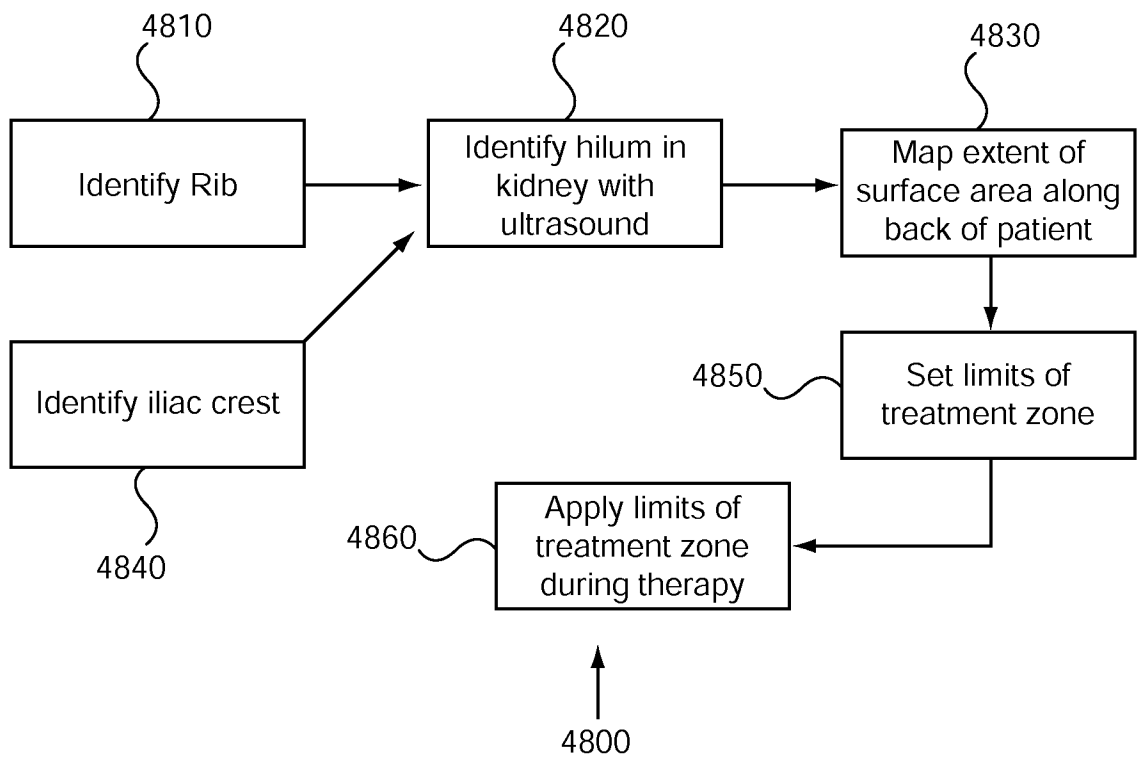

FIG. 71

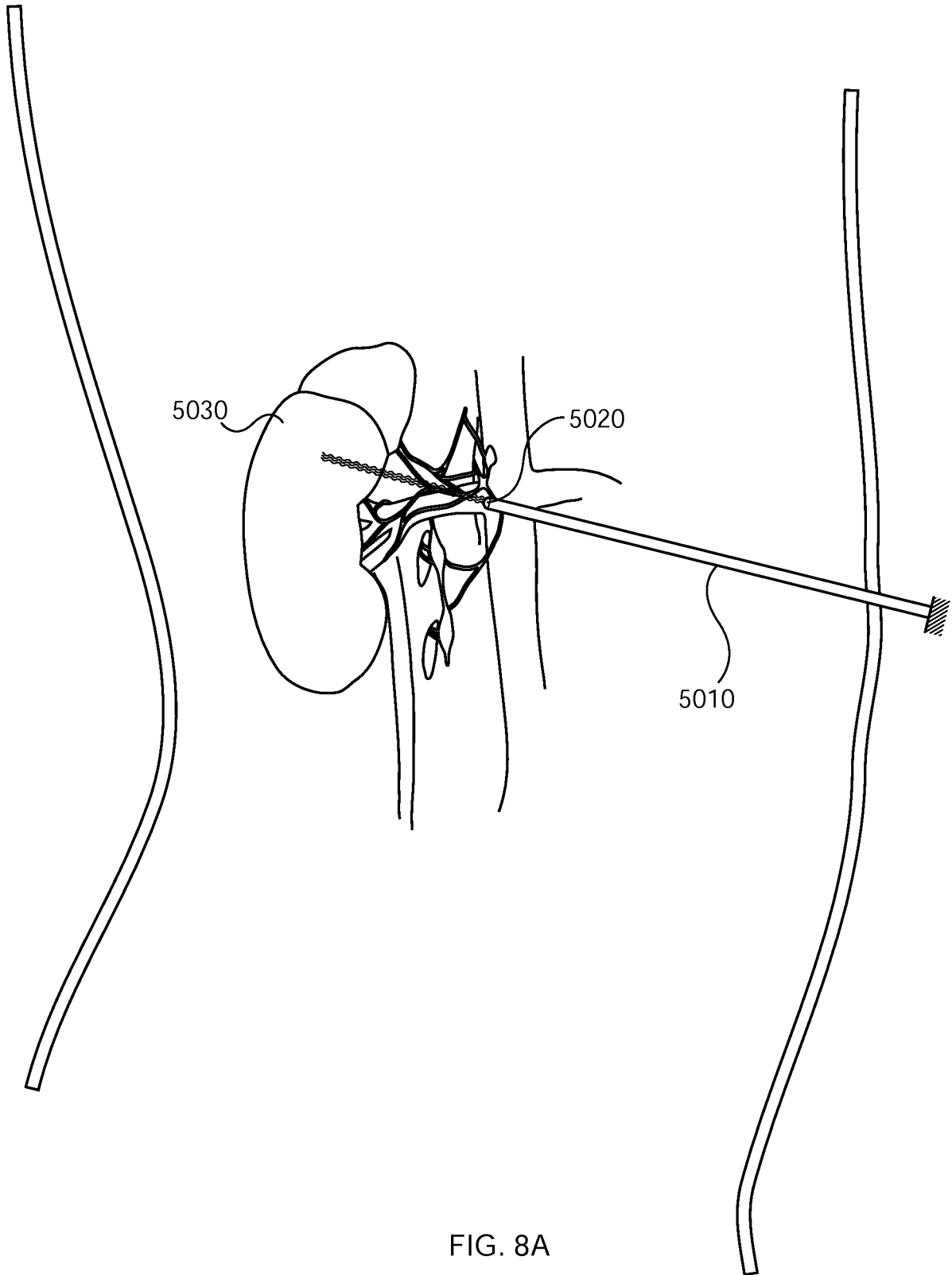

FIG. 8A

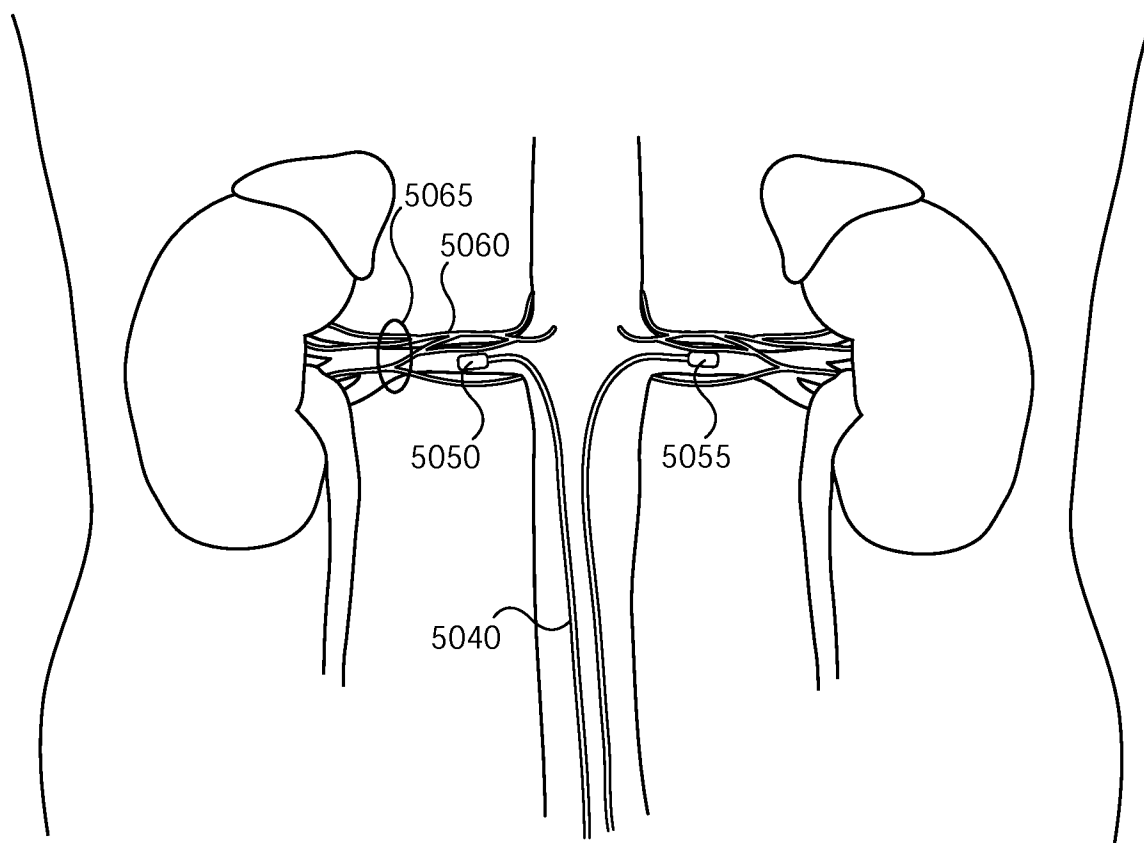

FIG. 8B

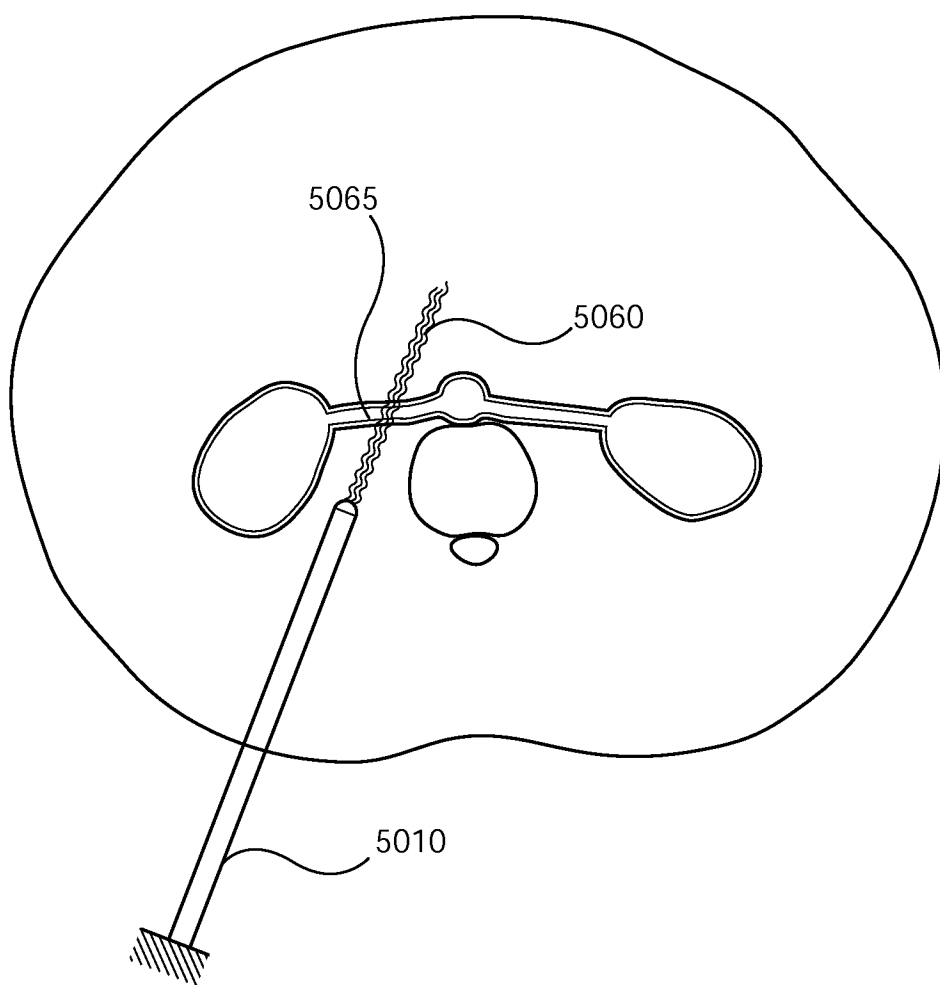

FIG. 8C

FIG. 9A

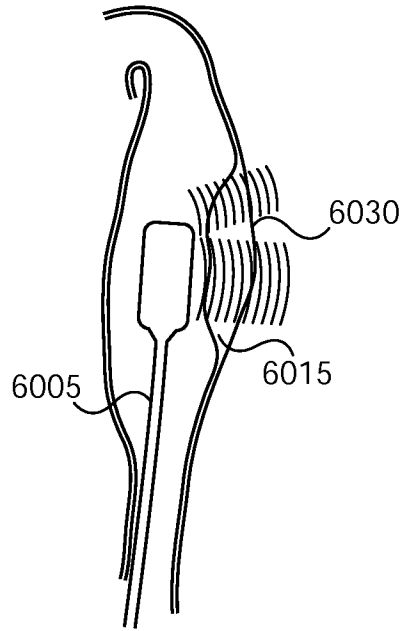

FIG. 9B

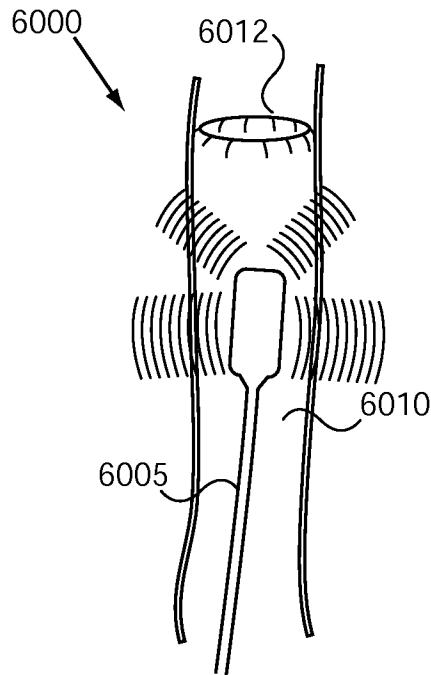
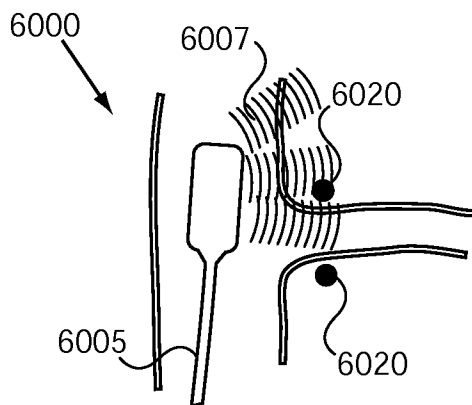

FIG. 9C



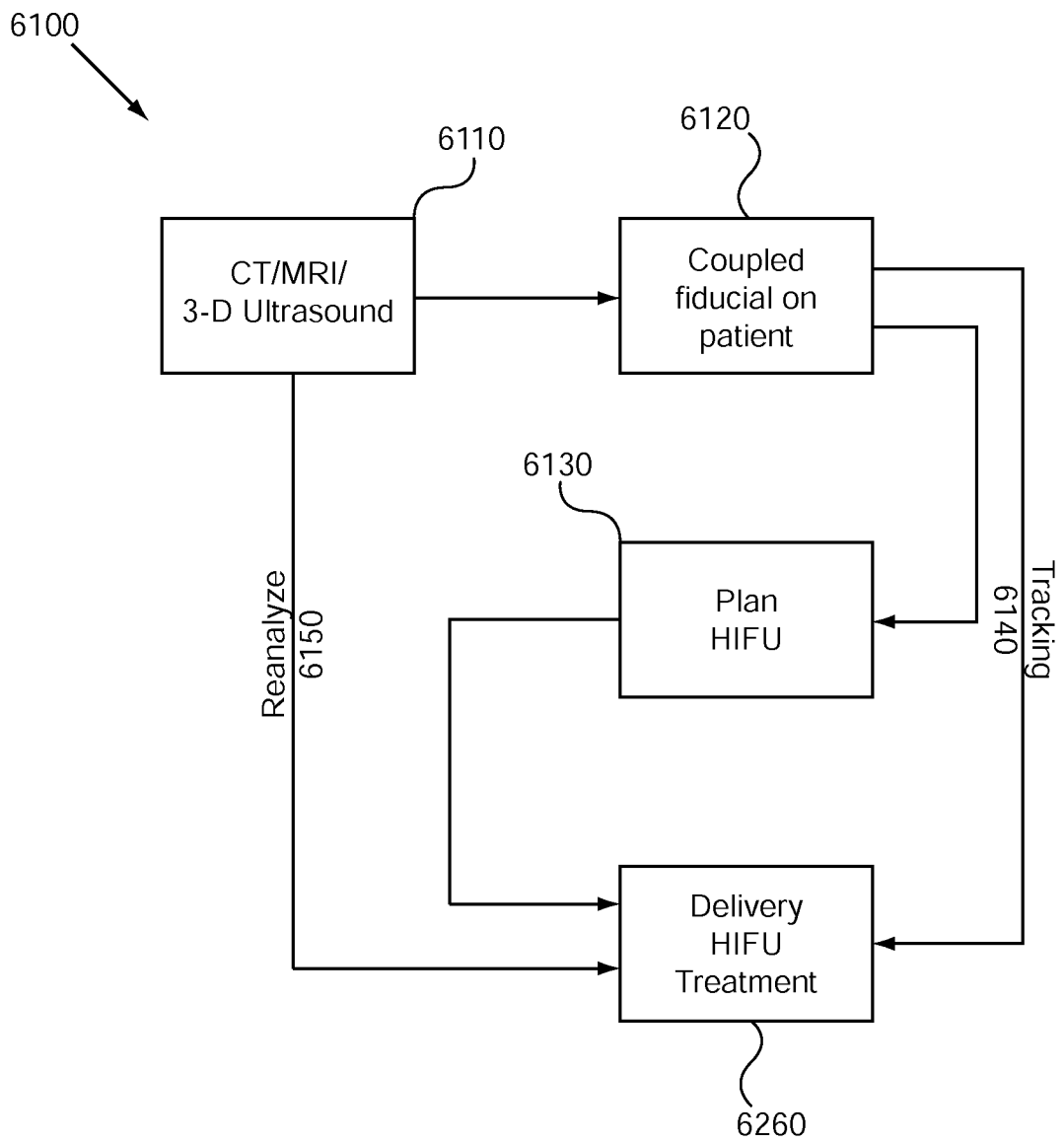

FIG. 10

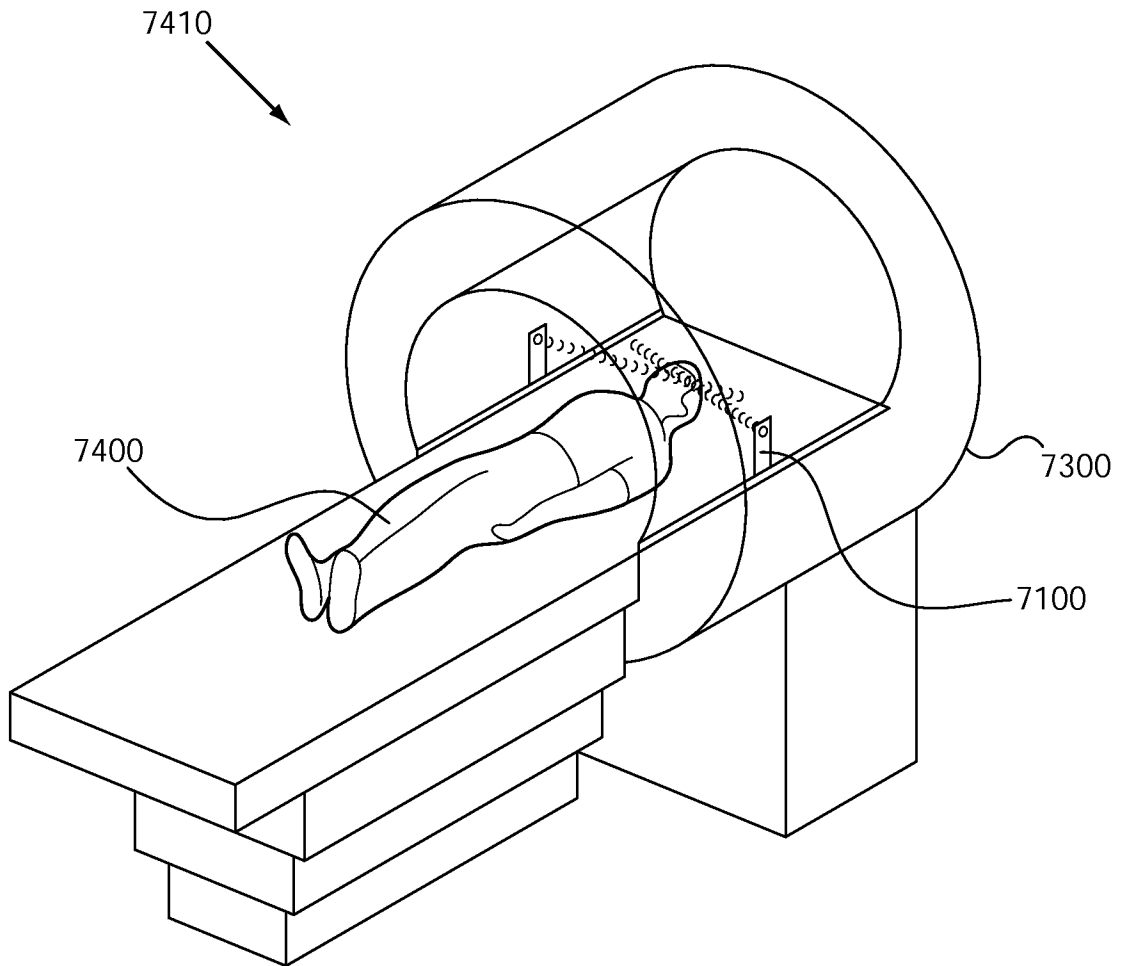

FIG. 11A

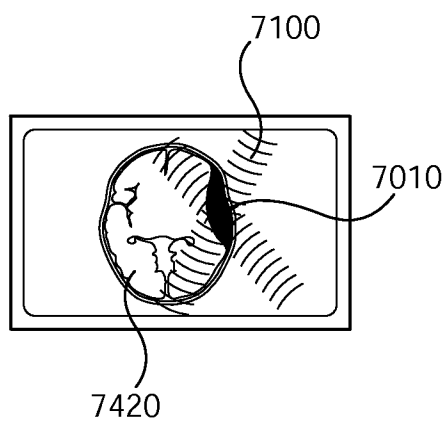

FIG. 11B

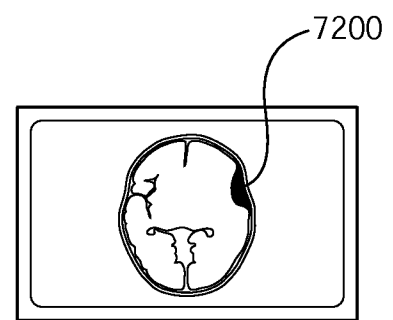

FIG. 11C

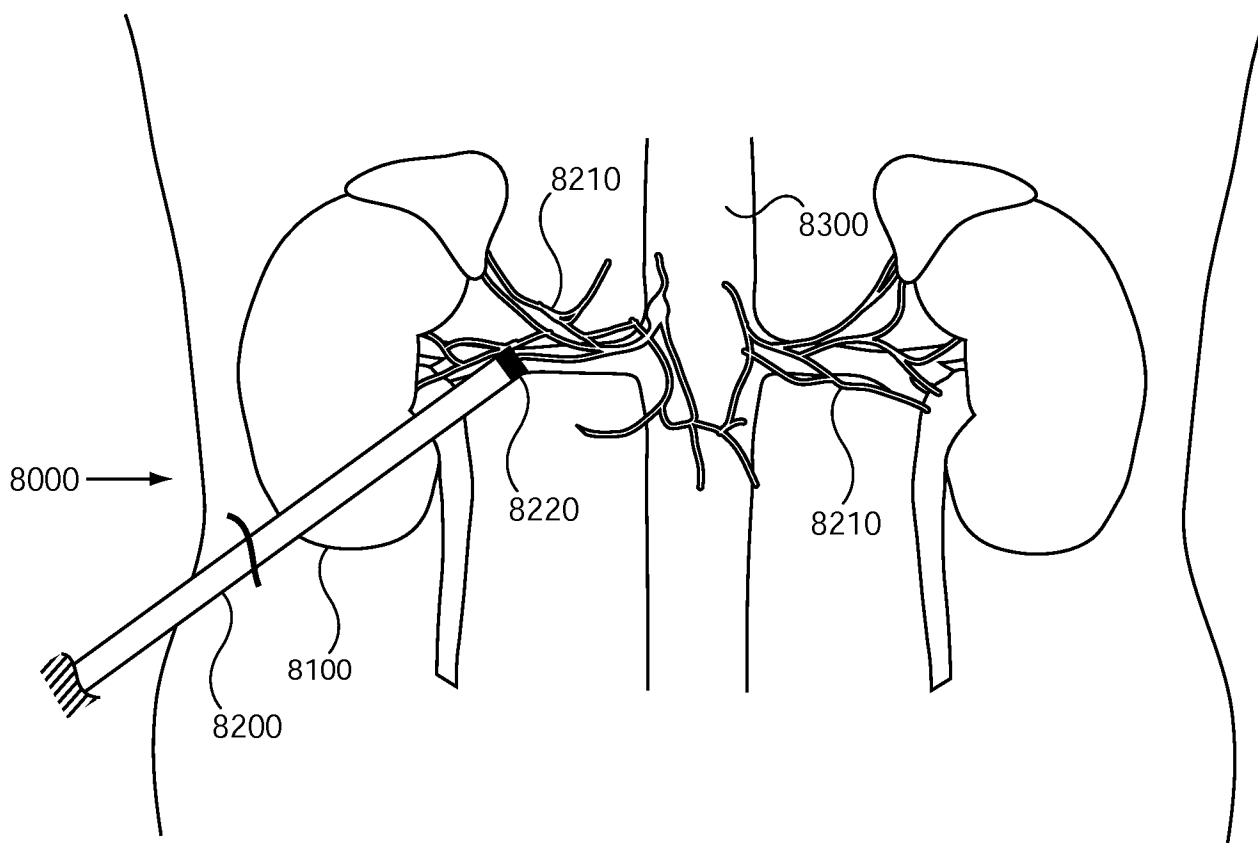

FIG. 12

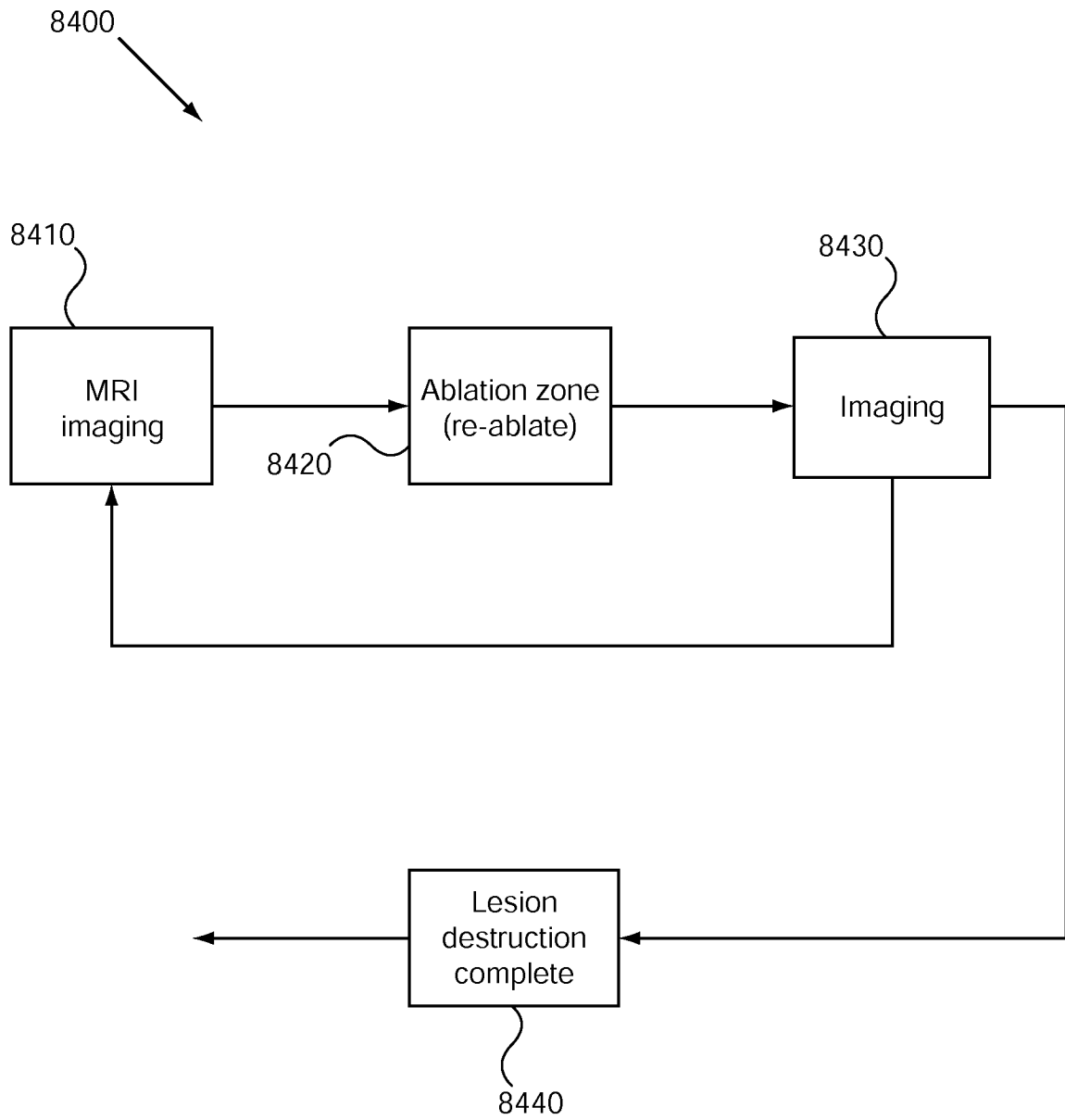

FIG. 13

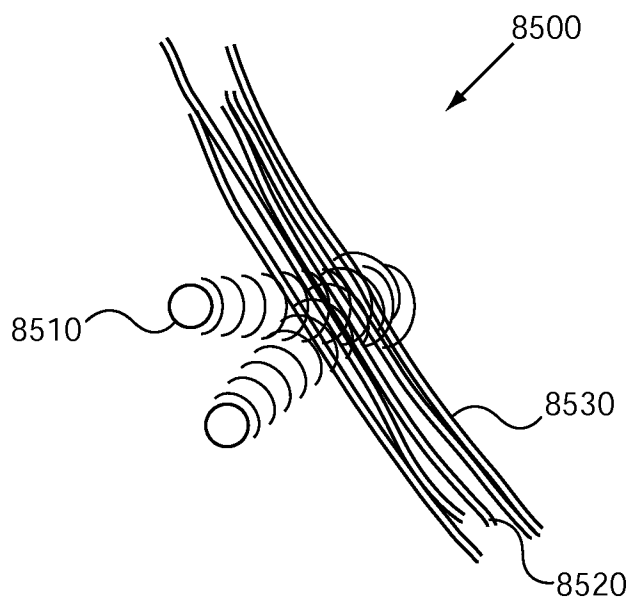

FIG. 14

26/51

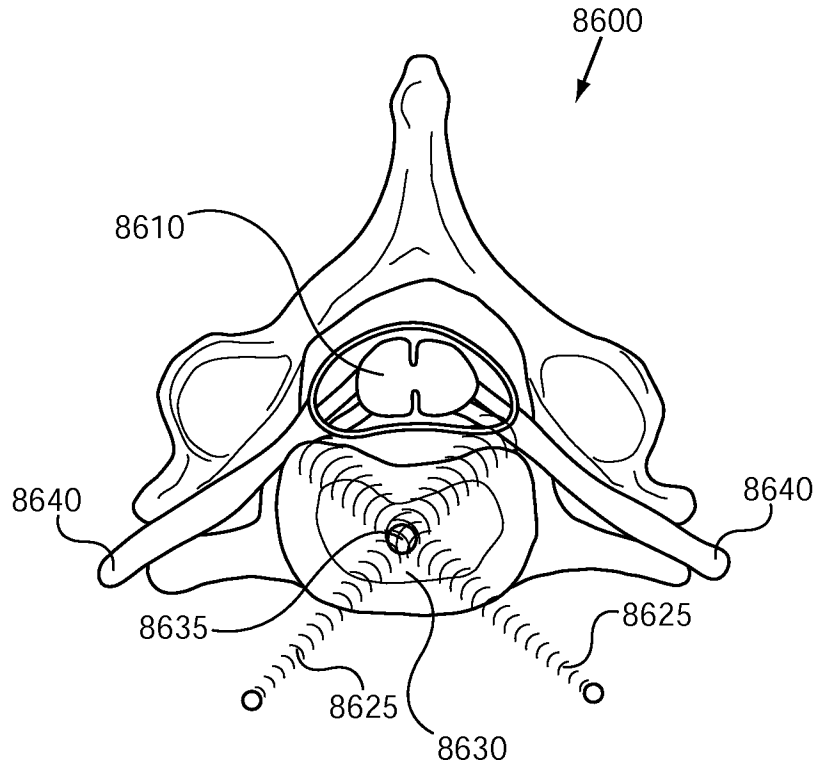

FIG. 15A

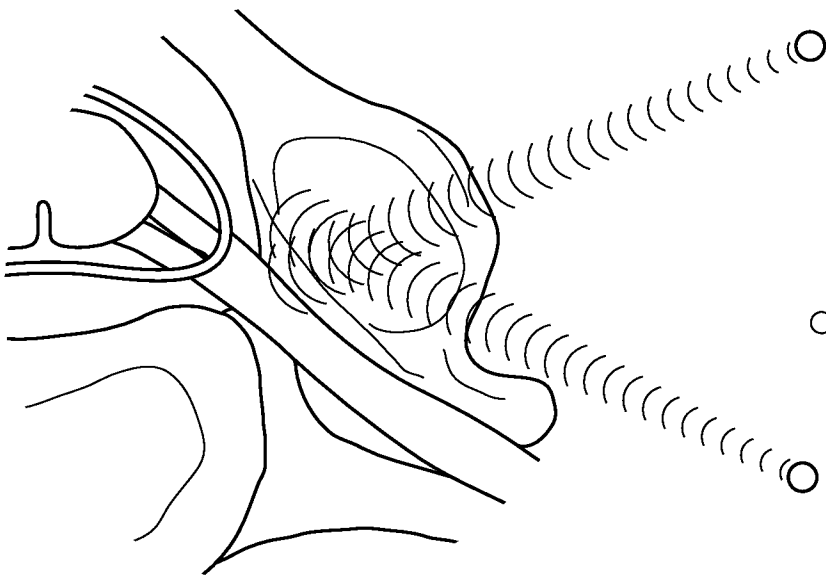

FIG. 15B

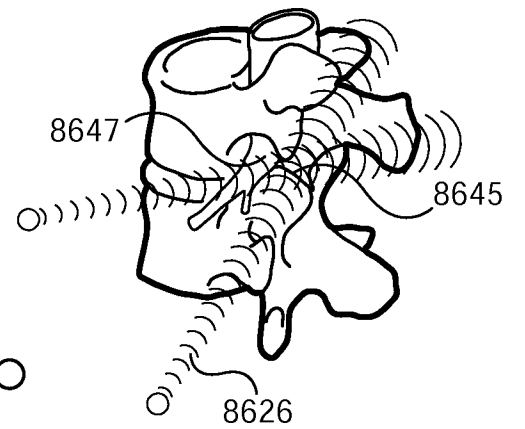

FIG. 15C

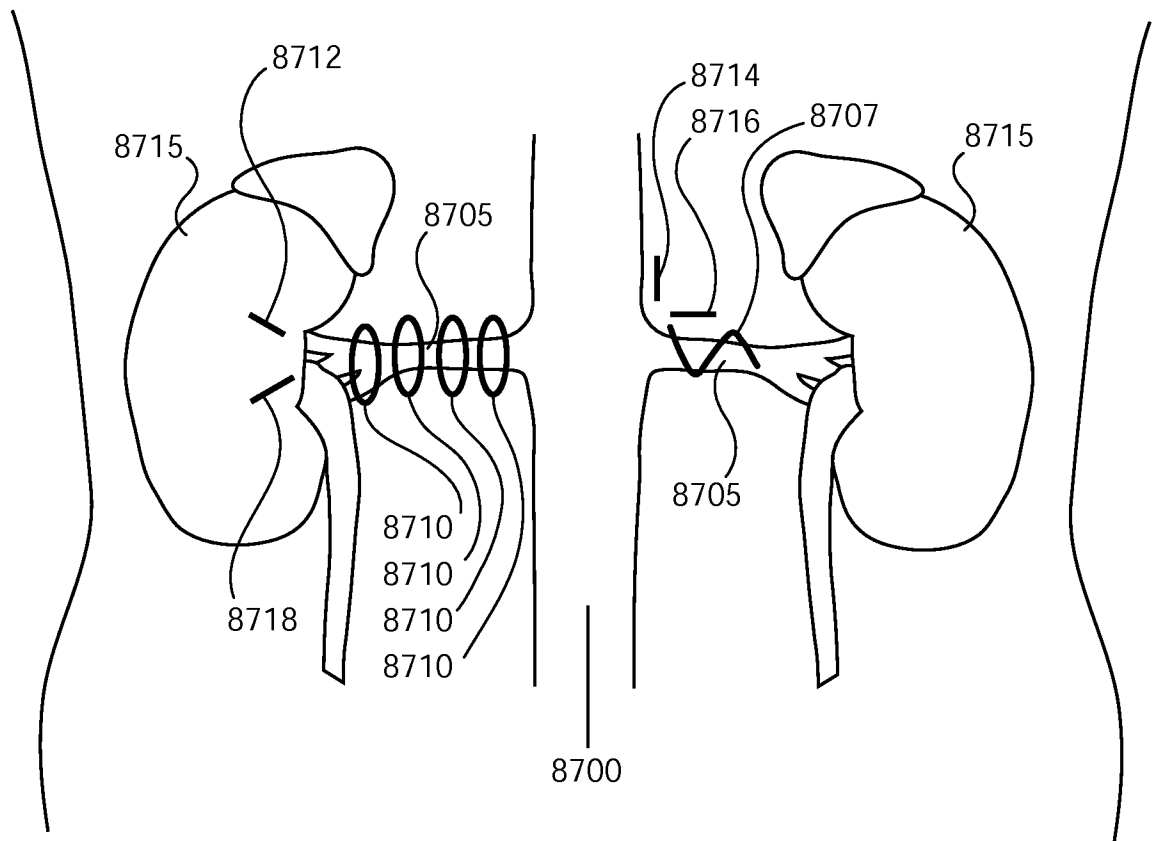

FIG. 16A

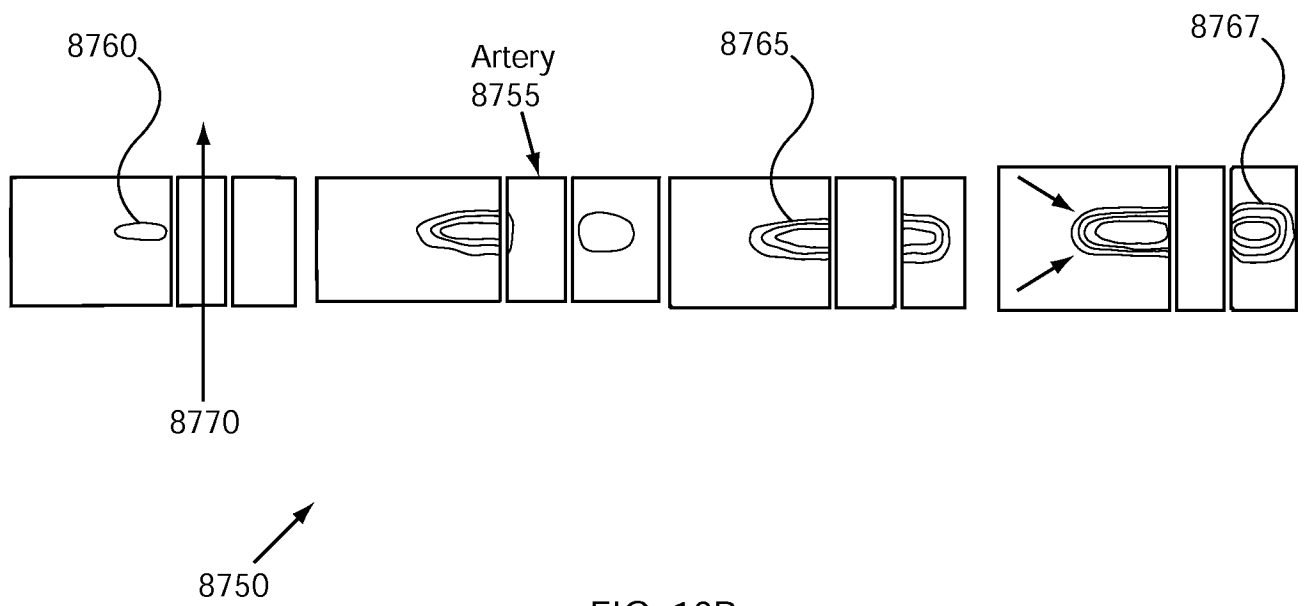

FIG. 16B

Cat Results (pg/ml)	Cortex NE Conc. (ng/g)	Avg. Cortex NE (ng/g)	Procedure
456	5	5	HIFU
543	5		HIFU
28,135	281	347	Control
41,280	413		Control
328	3	2	HIFU
96	1		HIFU
30,480	305	352	Control
39,840	398		Control

Callouts: 8780 (top left), 8780 (top middle), 8782 (top right), 8784 (middle right), 8742 (bottom left), 8782 (bottom right).

FIG. 16C

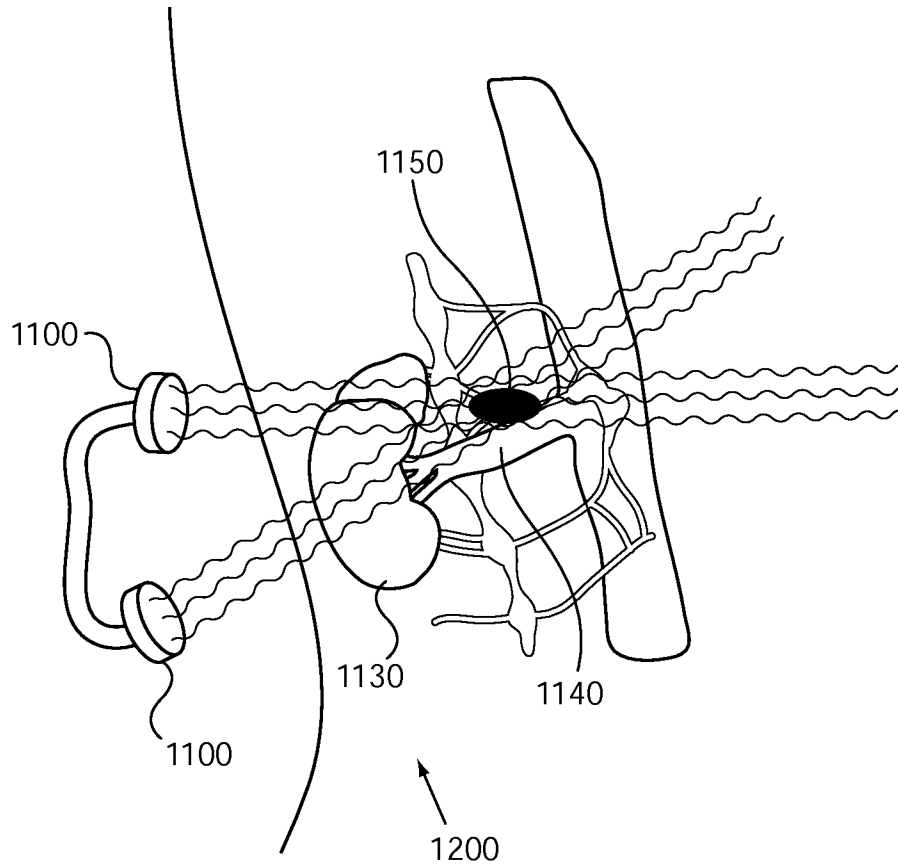

FIG. 17A

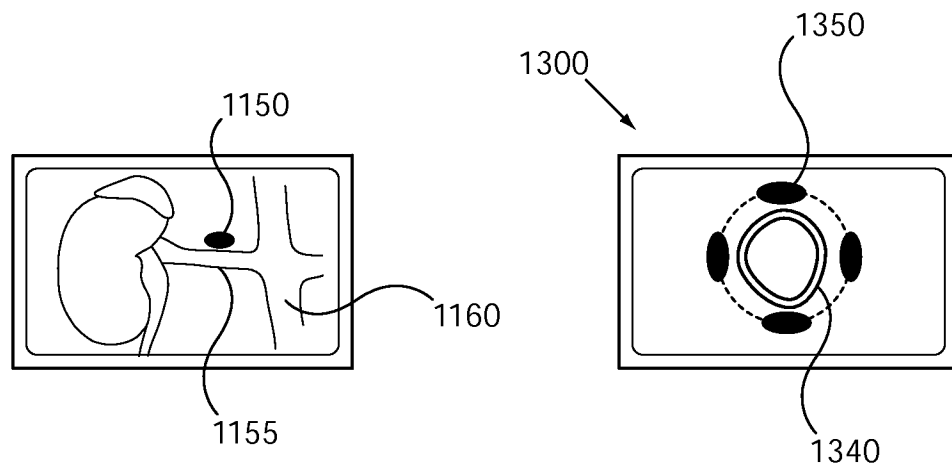

FIG. 17B

FIG. 17C

31/51

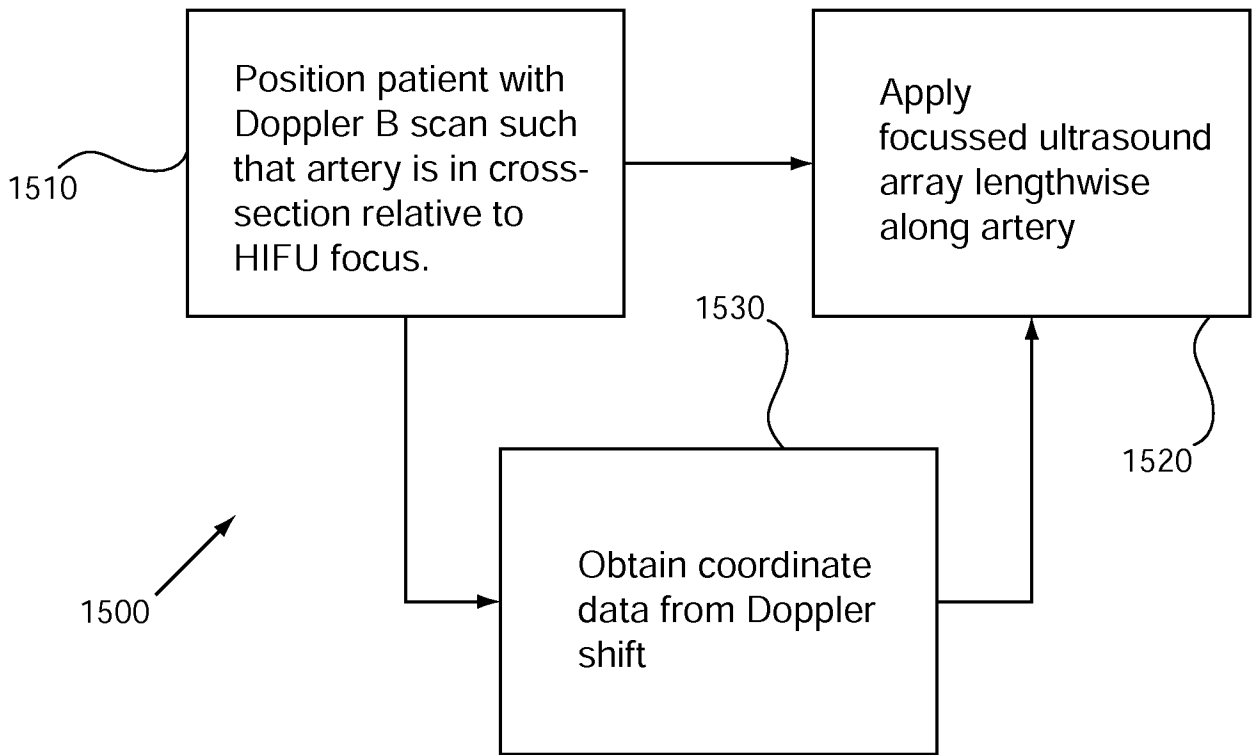

FIG. 17D

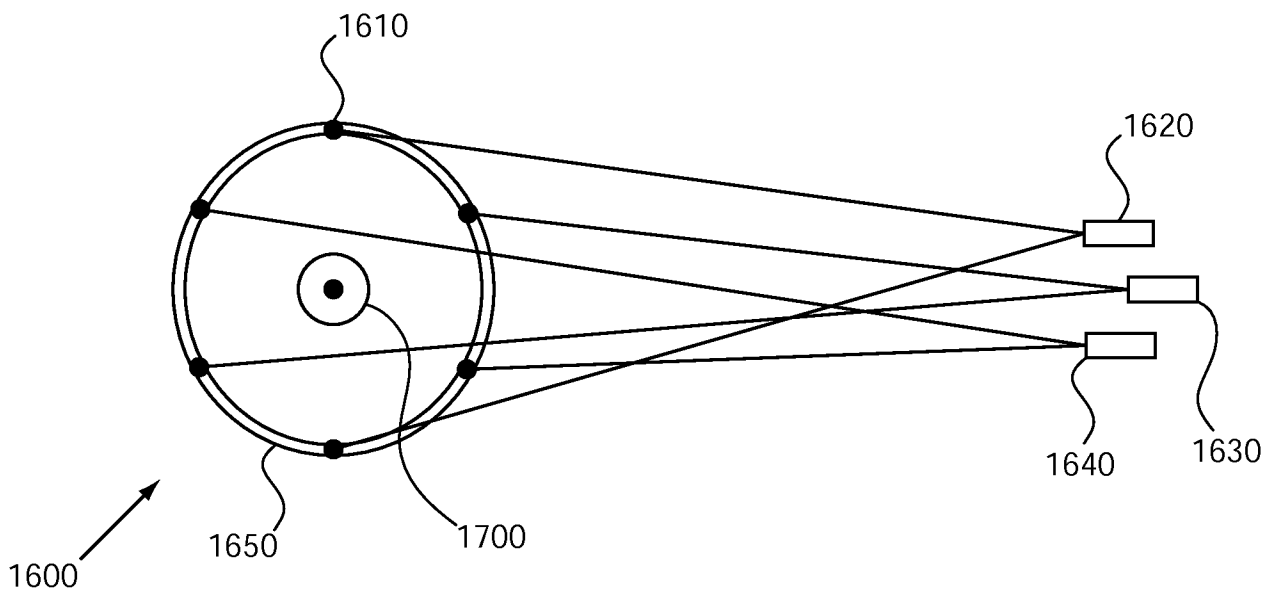

FIG. 17E

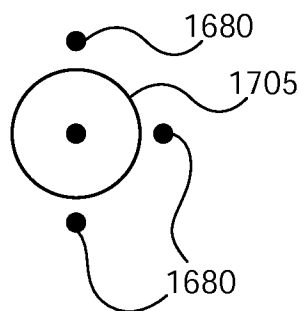

FIG. 17F

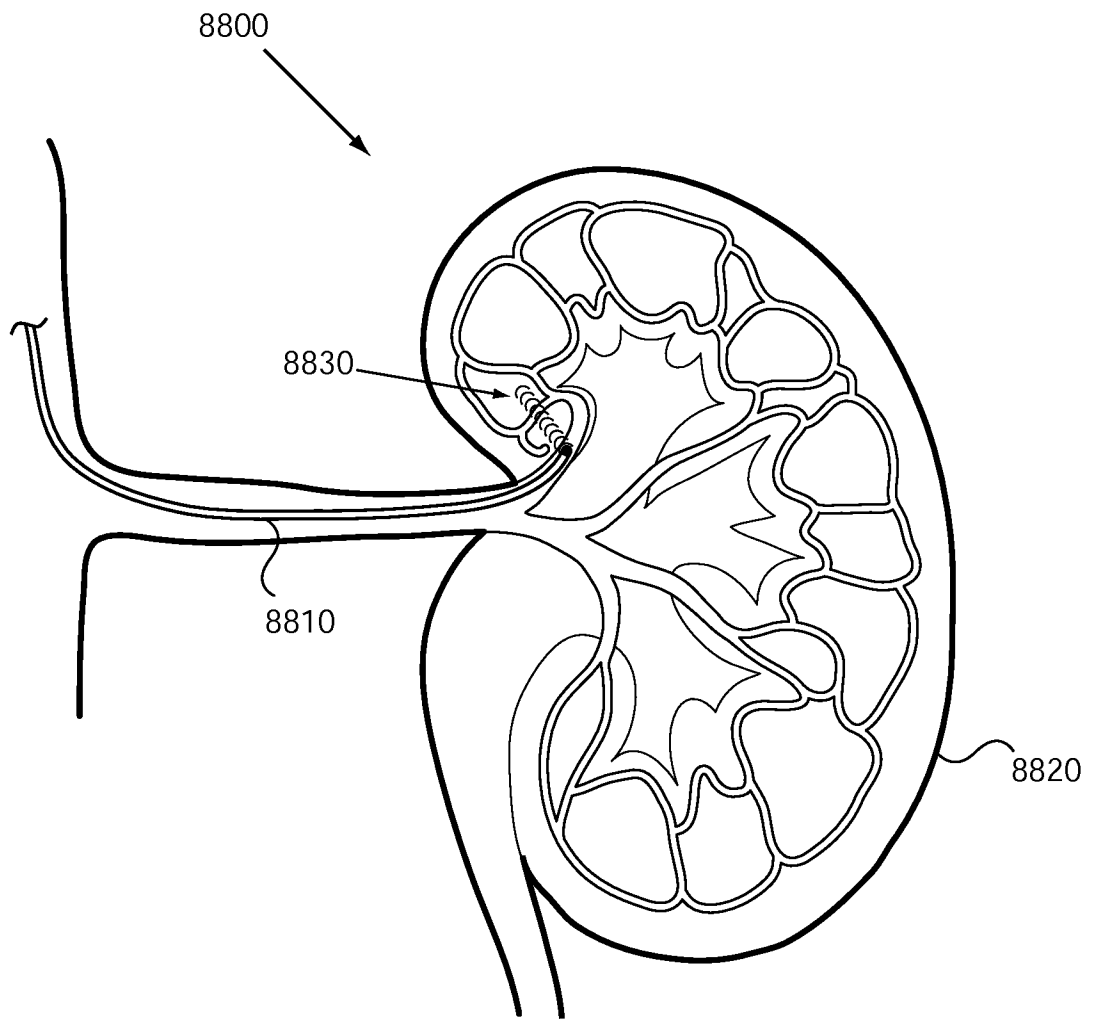

FIG. 18

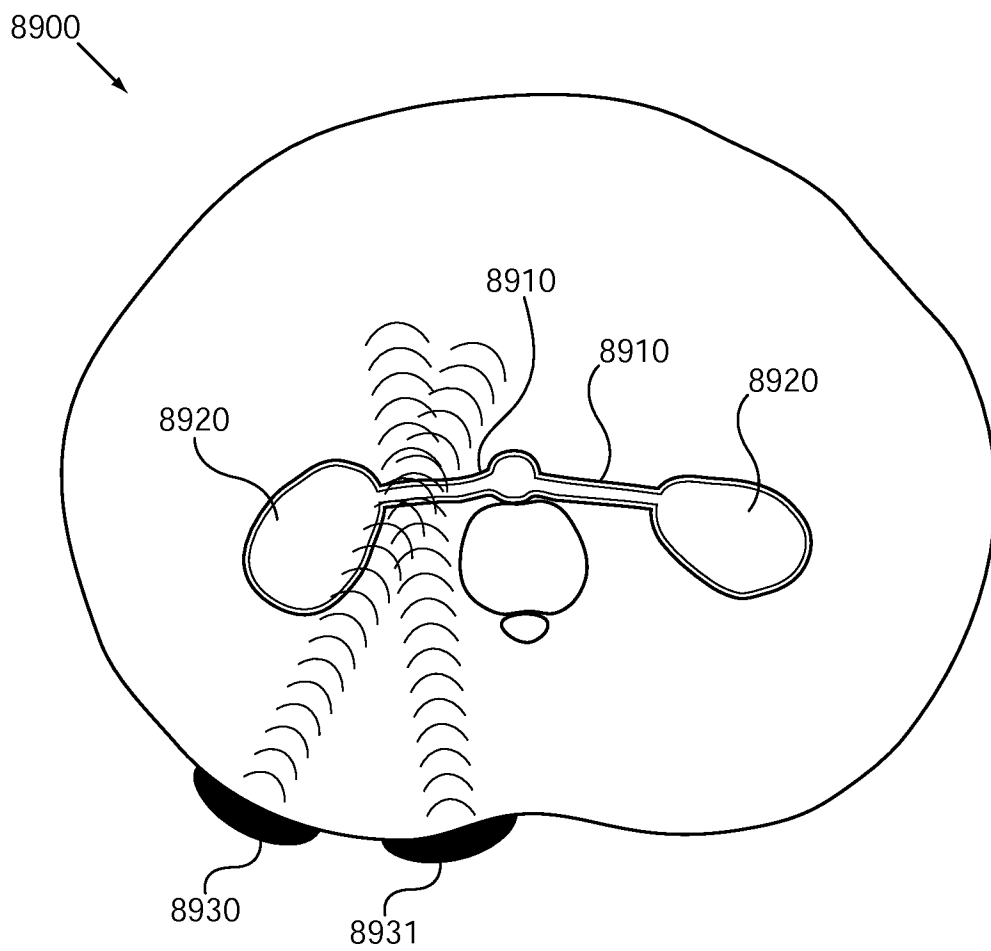

FIG. 19A

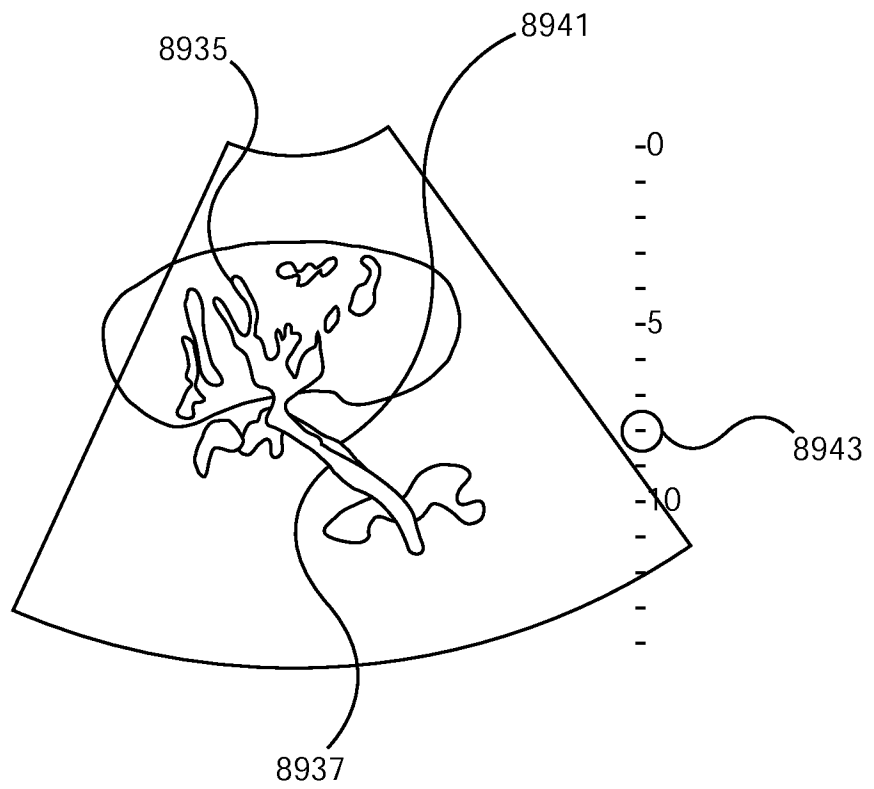

FIG. 19B

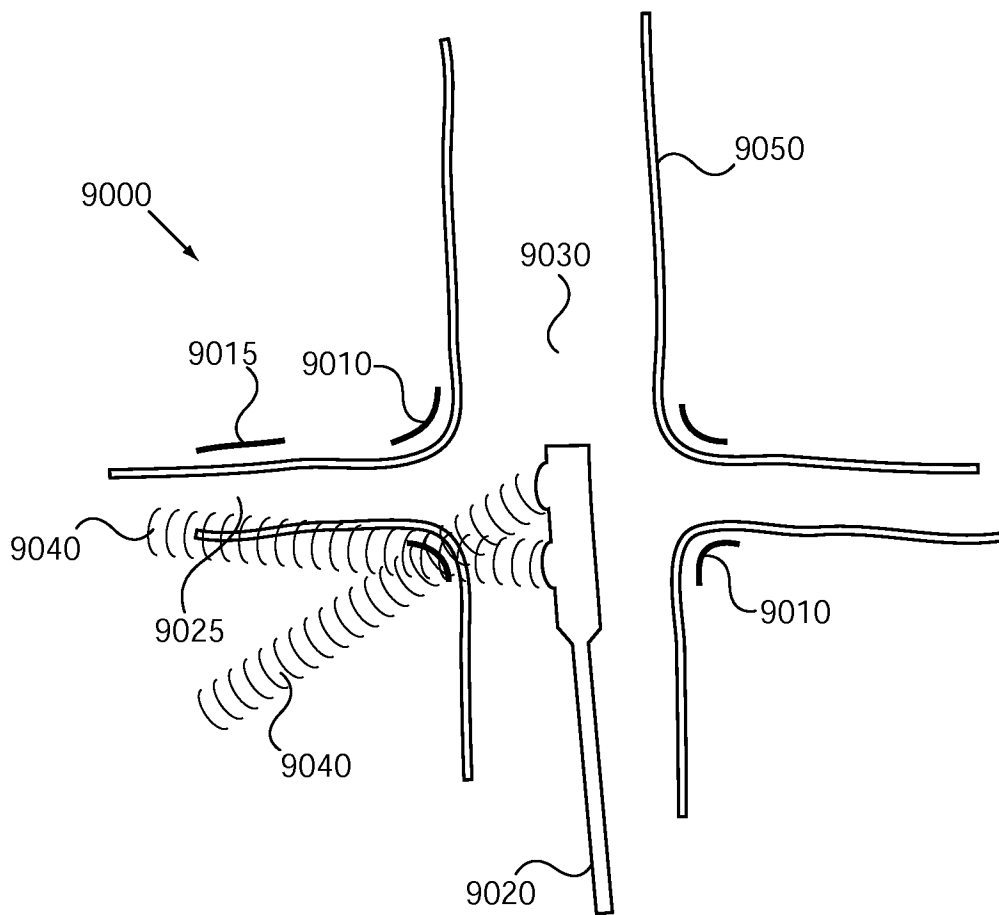

FIG. 20

36/51

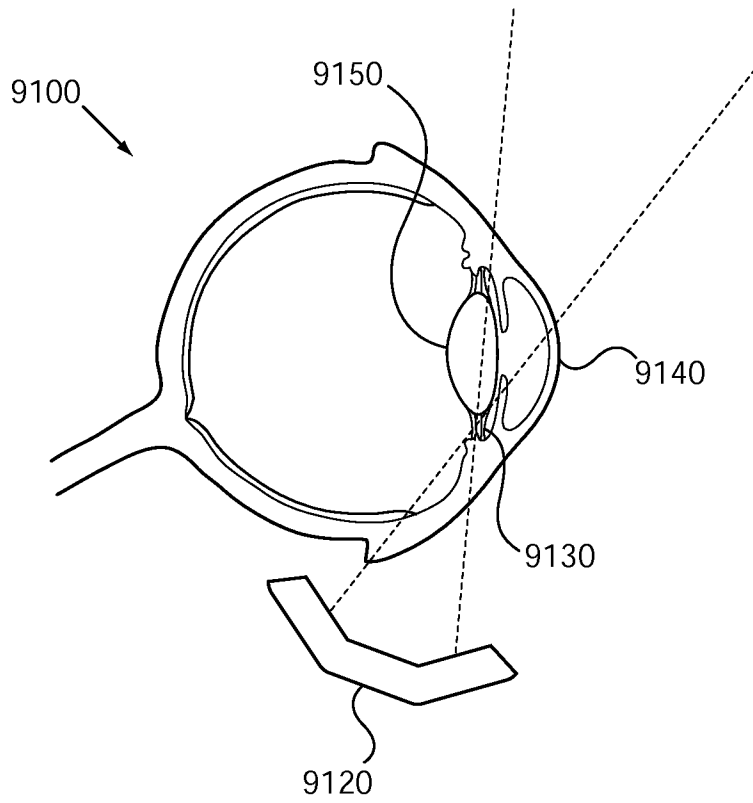

FIG. 21A

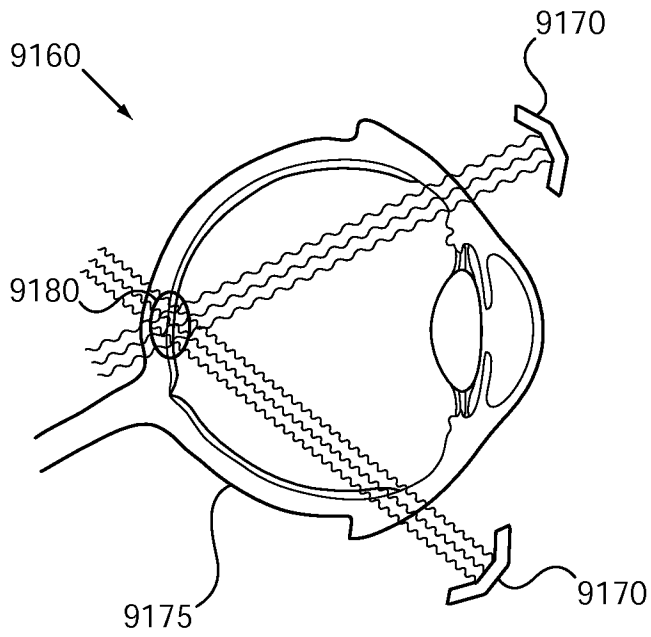

FIG. 21B

37/51

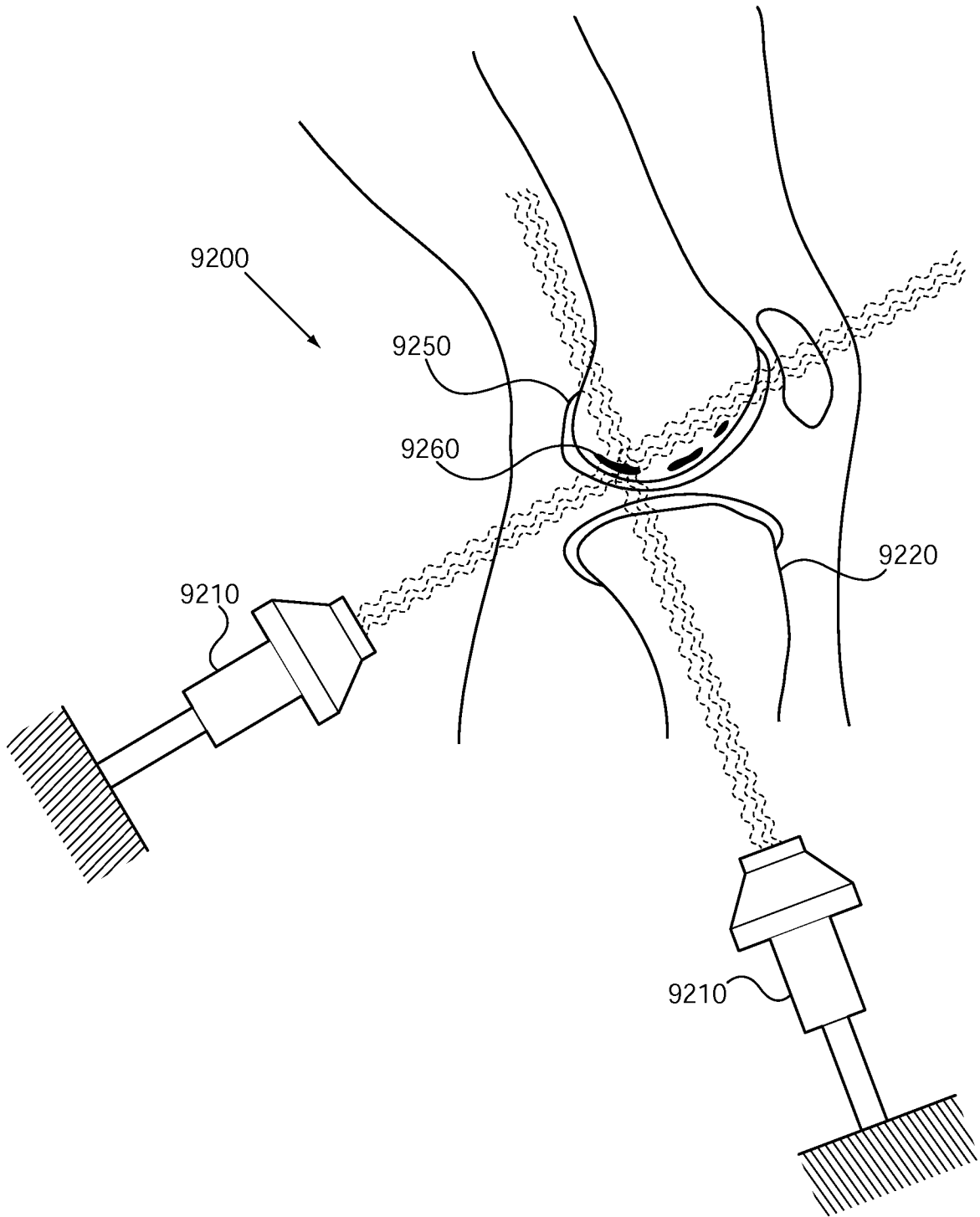

FIG. 22

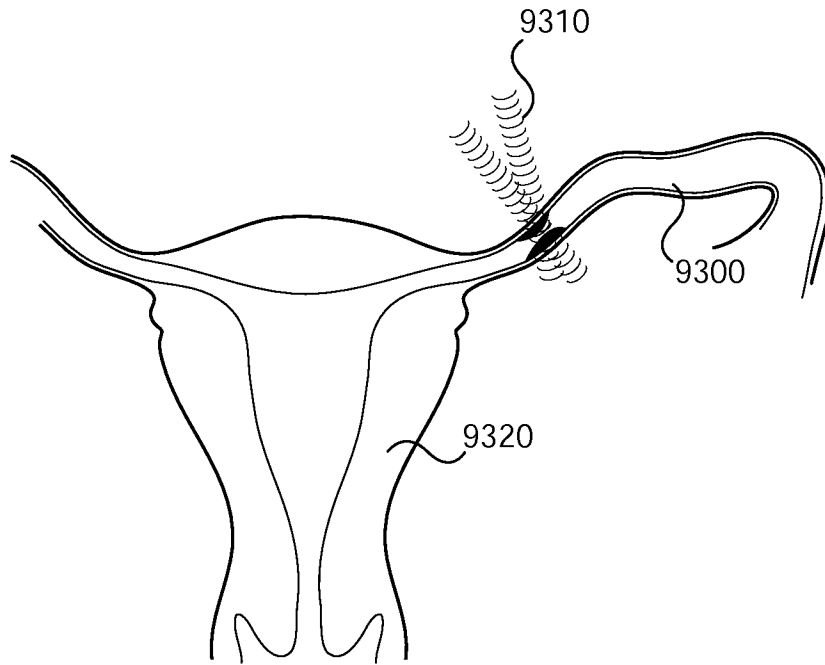

FIG. 23A

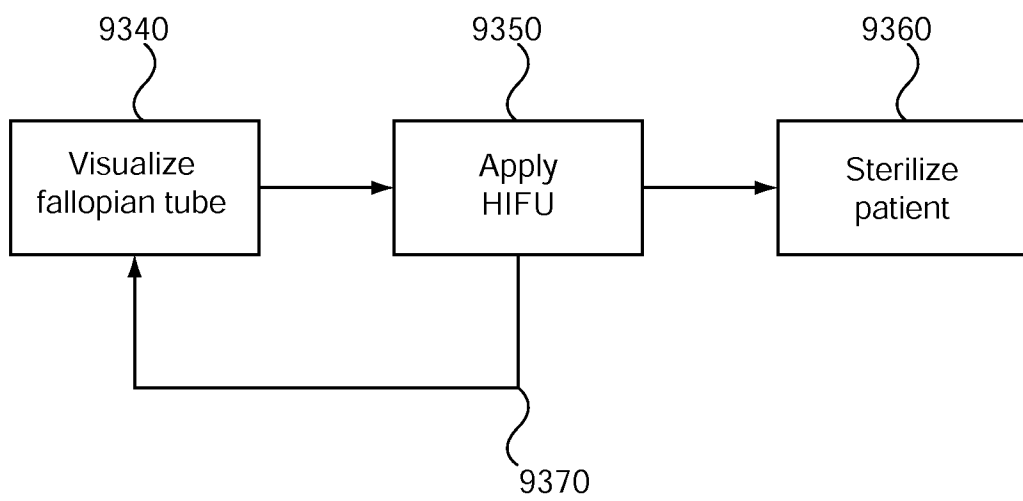

FIG. 23B

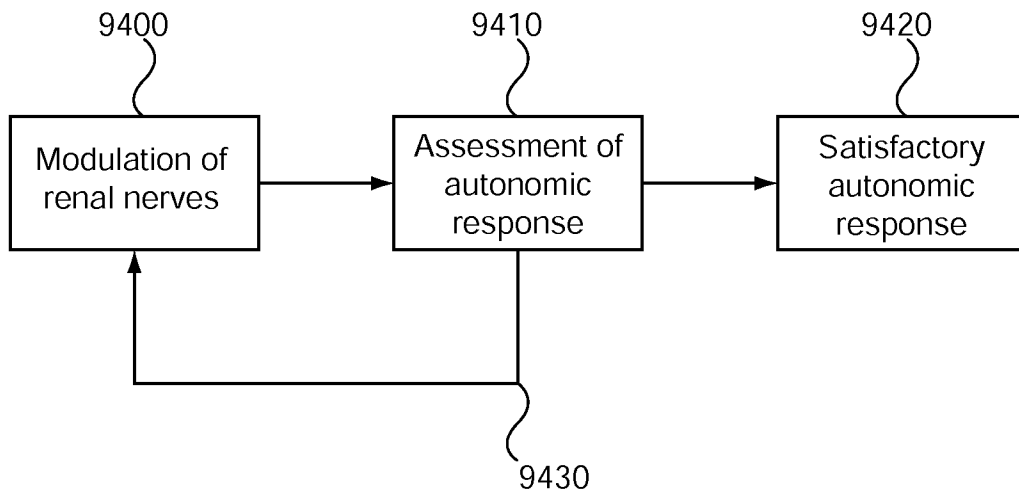

FIG. 24

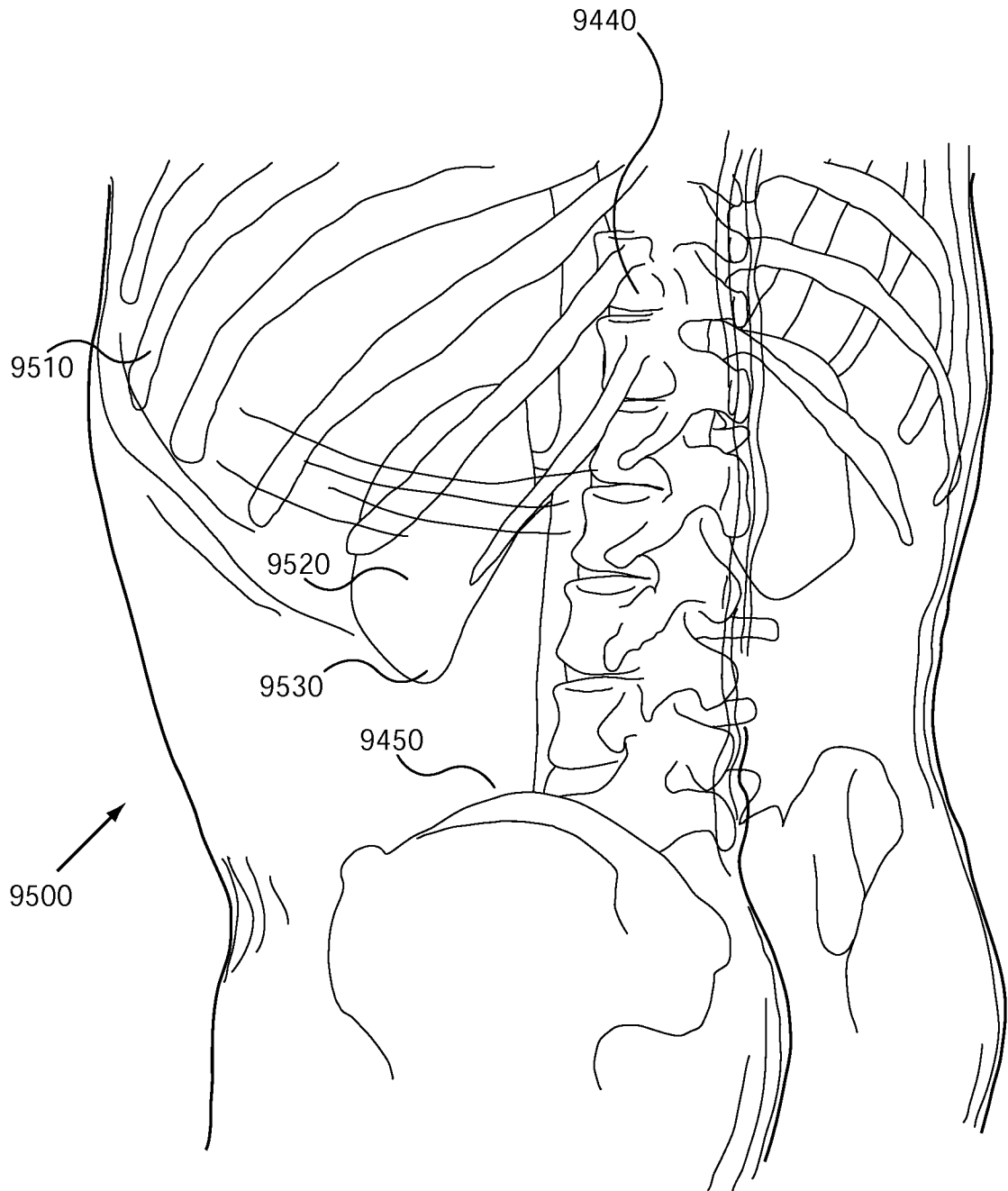

FIG. 25

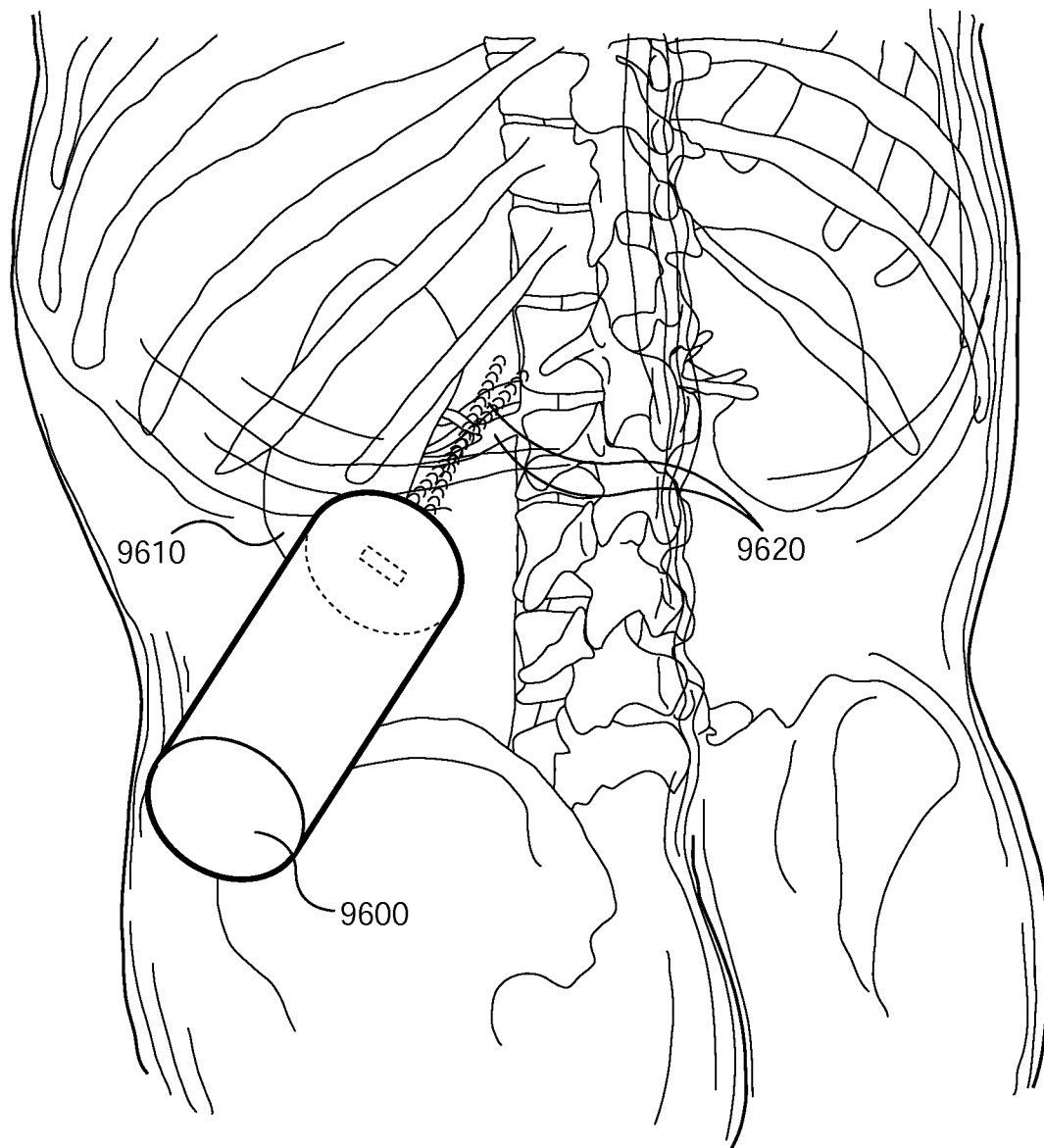

FIG. 26A

42/51

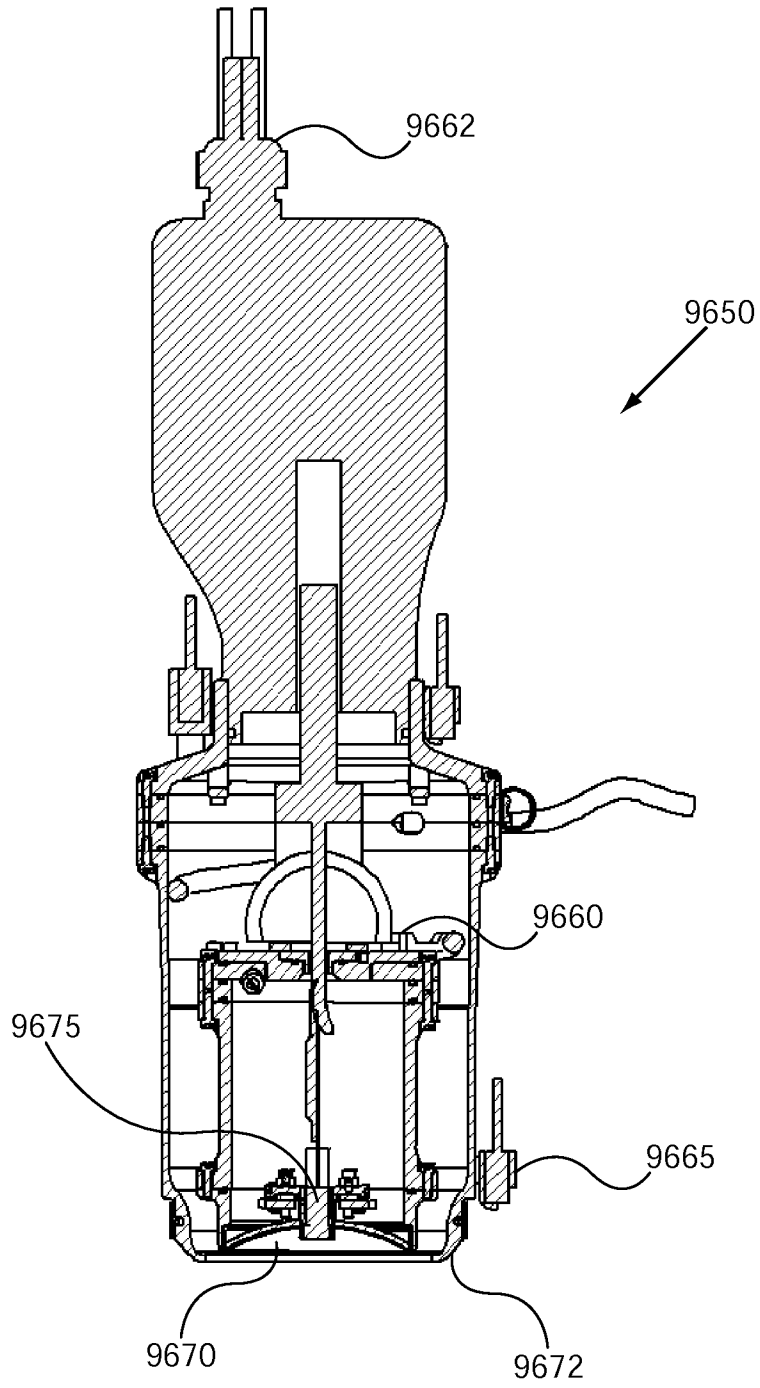

FIG. 26B

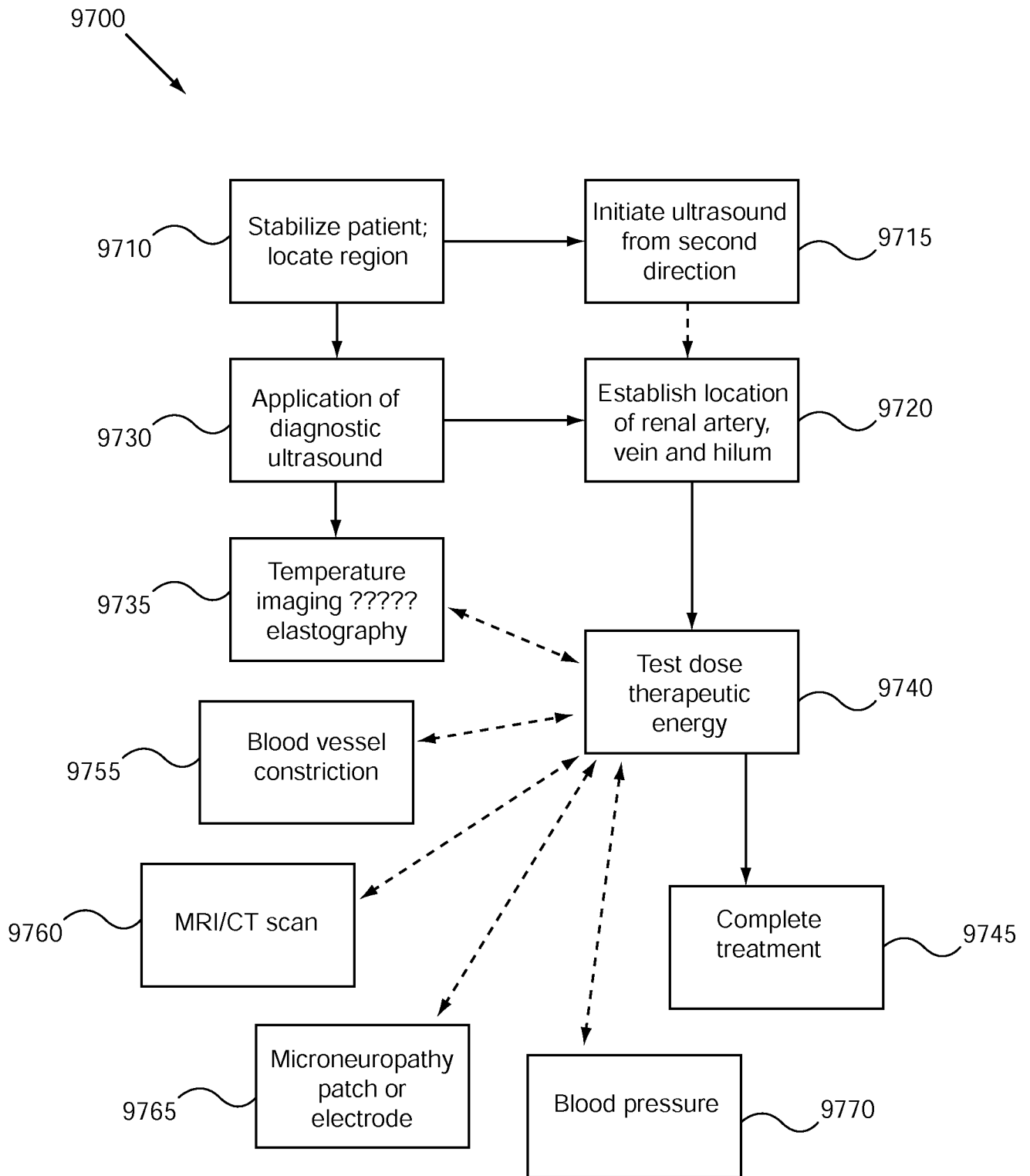

FIG. 27

44/51

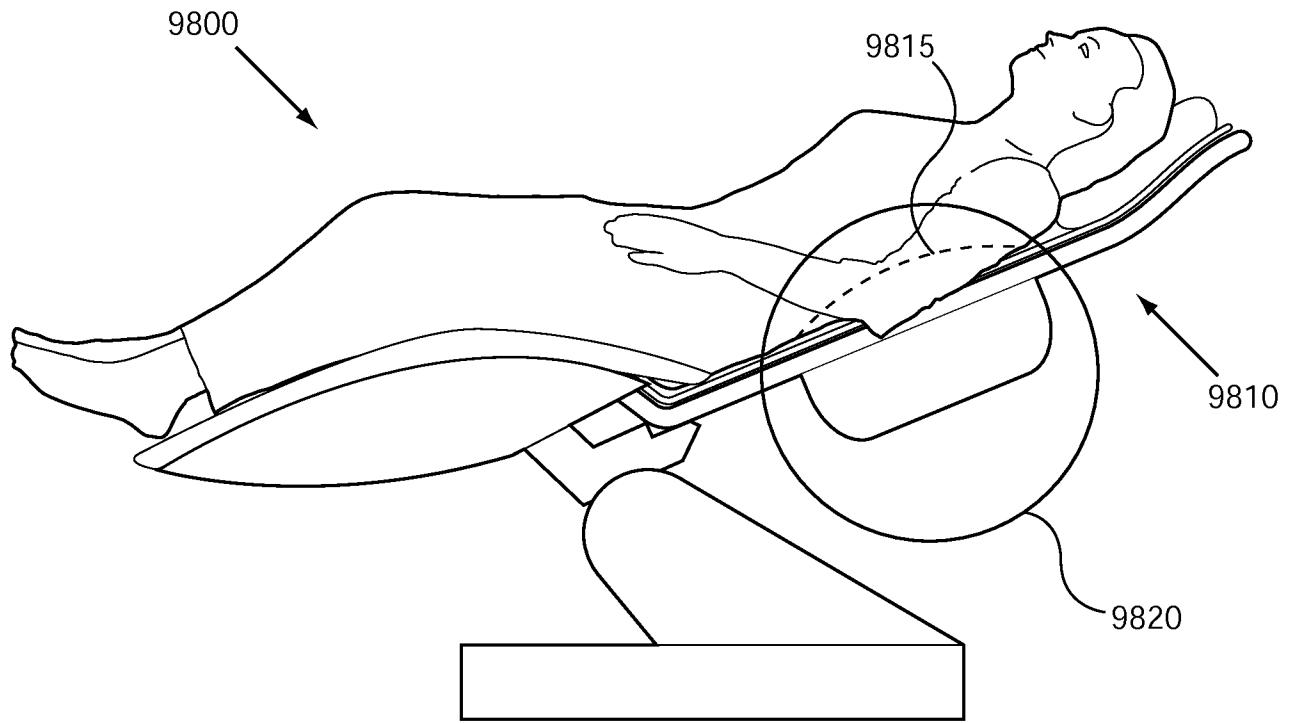

FIG. 28A

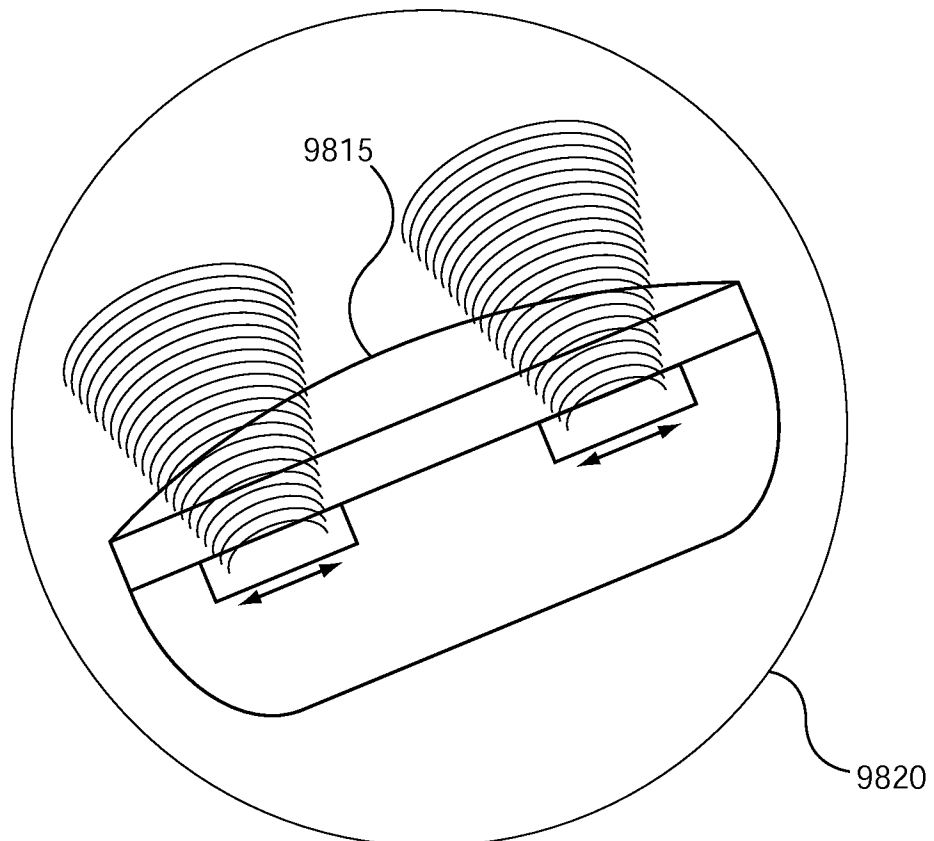

FIG. 28B

45/51

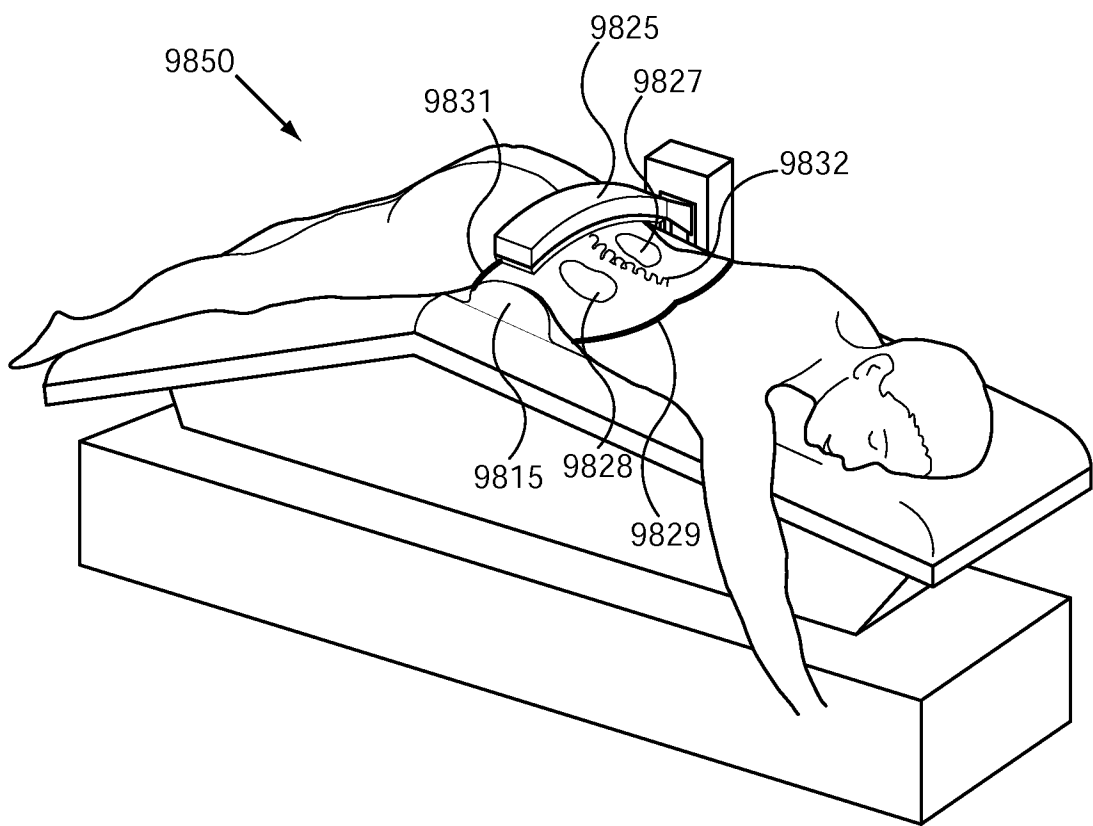

FIG. 28C

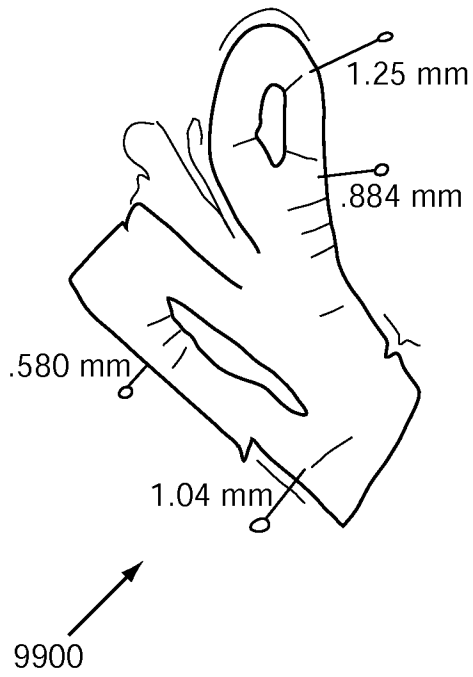

FIG. 29A

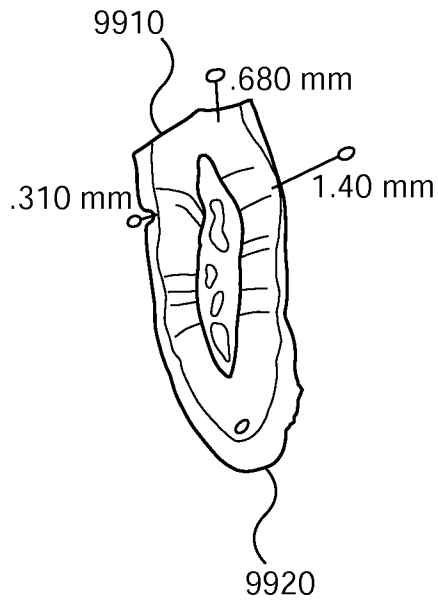

FIG. 29B

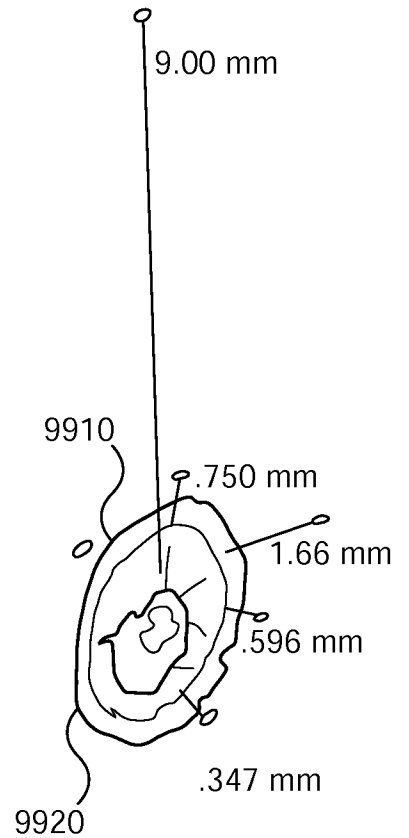

FIG. 29C

47/51

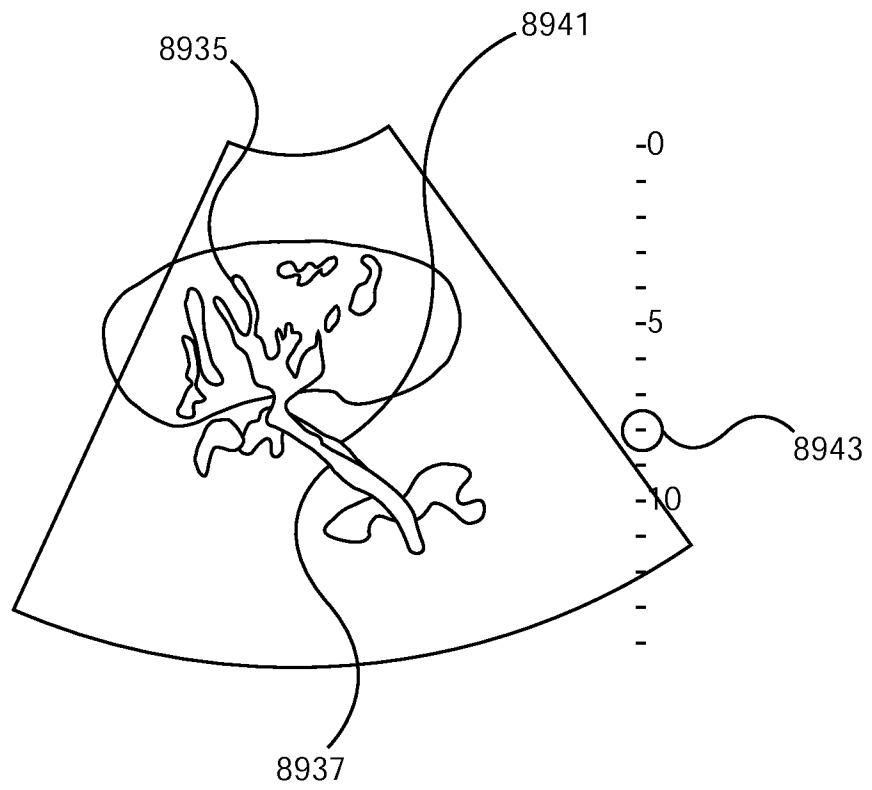

FIG. 29D

Target skin region

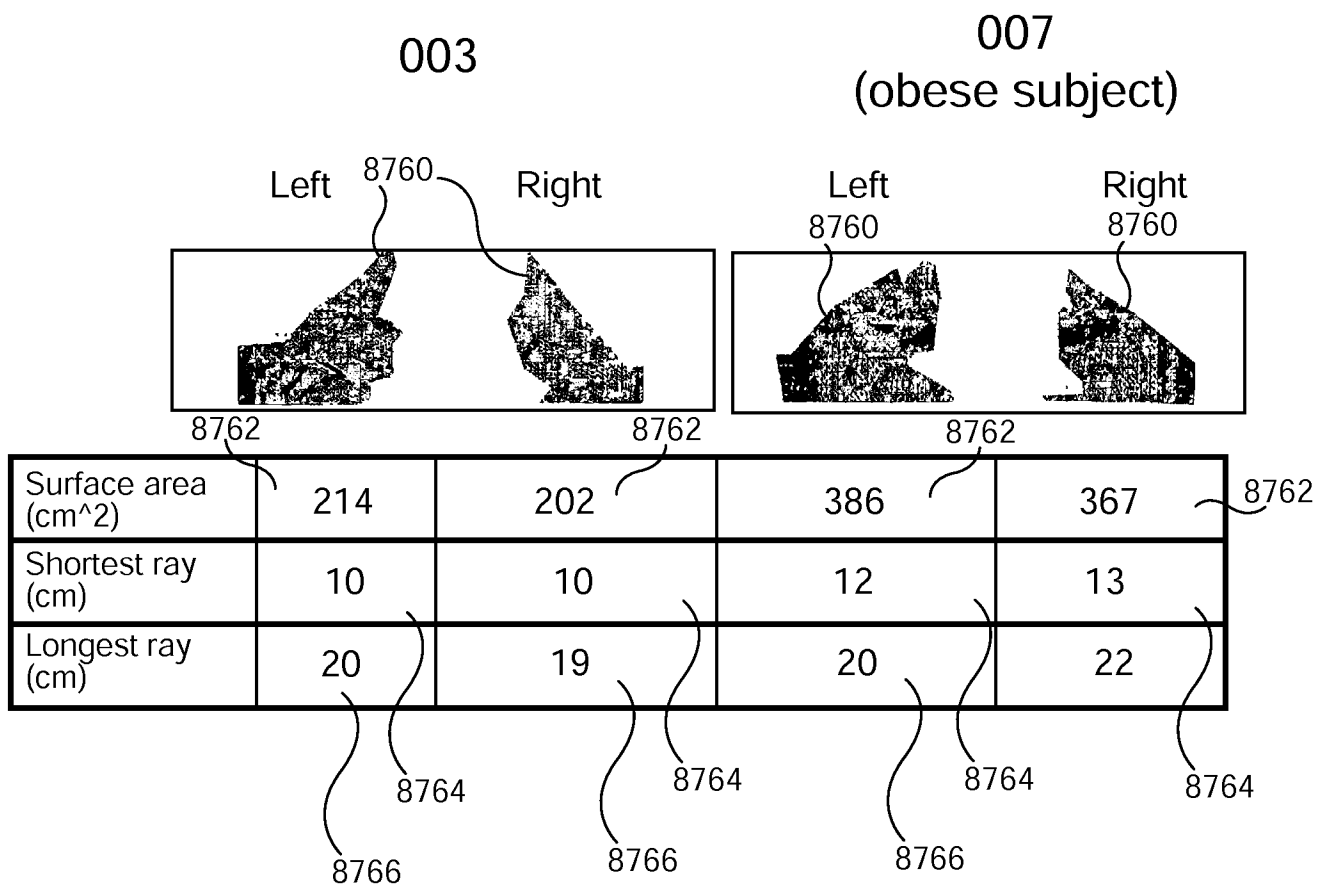

FIG. 29E

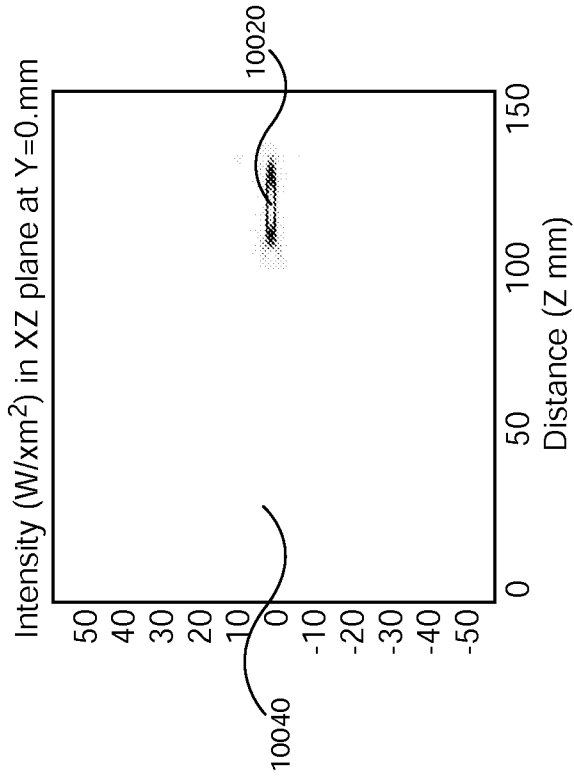

FIG. 30B

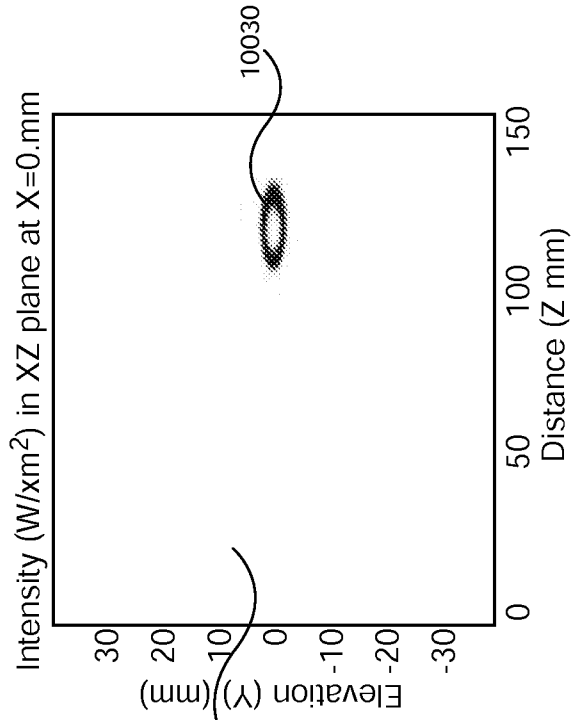

FIG. 30C

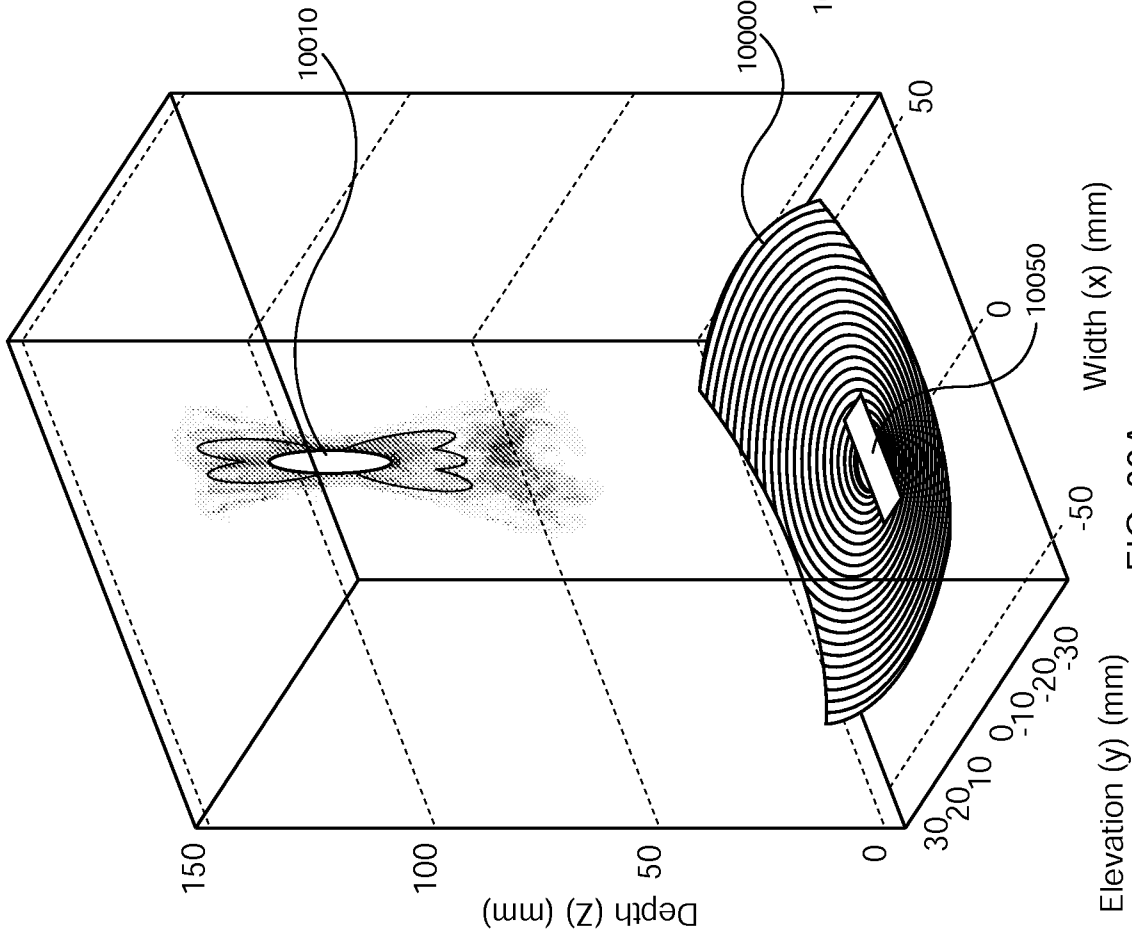

FIG. 30A

50/51

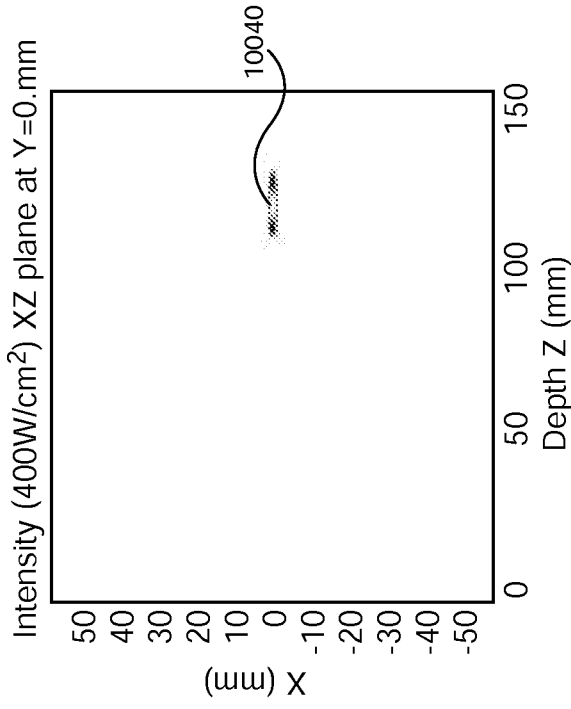

FIG. 30E

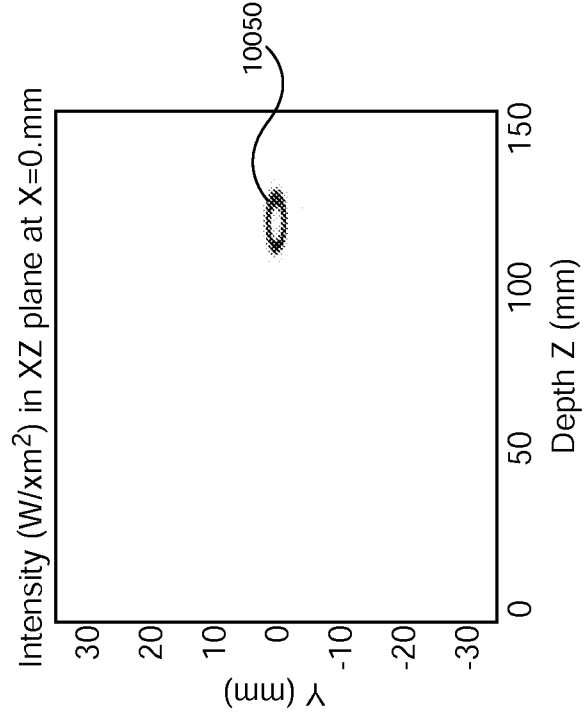

FIG. 30F

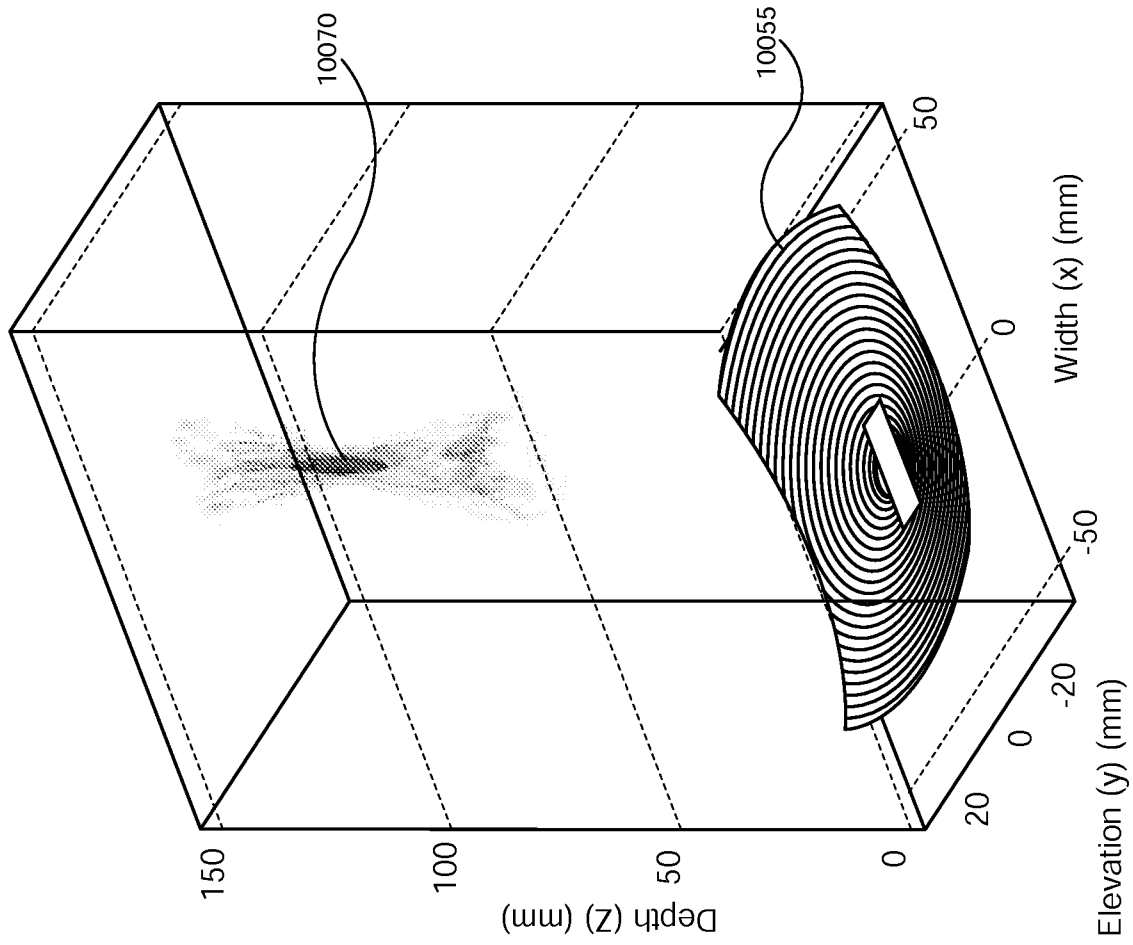

FIG. 30D

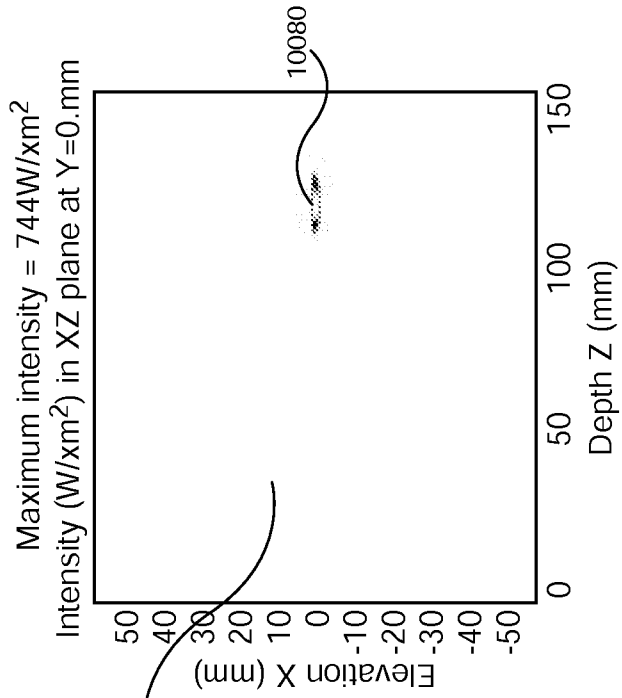

FIG. 30H

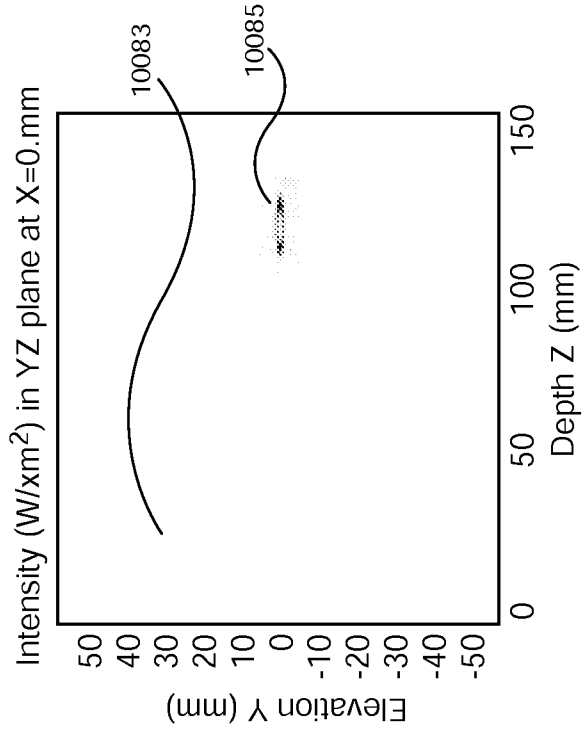

FIG. 30I

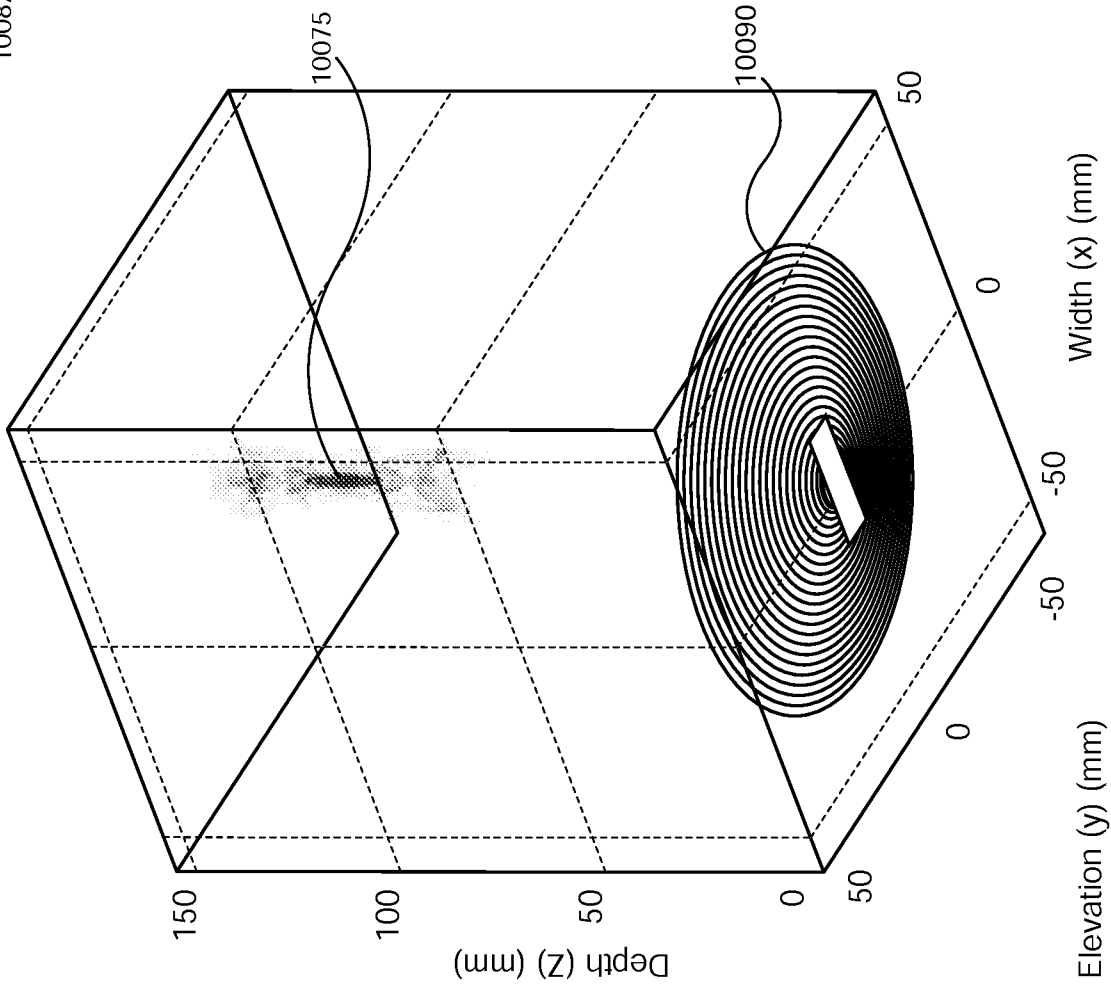

FIG. 30G

专利名称(译)	精力充沛地调节神经		
公开(公告)号	EP2488250A2	公开(公告)日	2012-08-22
申请号	EP2010823909	申请日	2010-10-11
申请(专利权)人(译)	KONA MEDICAL , INC.		
当前申请(专利权)人(译)	KONA MEDICAL , INC.		
[标]发明人	GERTNER MICHAEL		
发明人	GERTNER, MICHAEL		
IPC分类号	A61N1/18 A61B6/00 A61B5/00 A61B8/06 A61N5/00 A61N5/067		
CPC分类号	A61N2/006 A61B5/0225 A61B5/055 A61B5/4035 A61B5/4041 A61B5/4047 A61B5/4052 A61B5/412 A61B5/4528 A61B5/4839 A61B5/489 A61B5/4893 A61B6/03 A61B6/032 A61B6/037 A61B6/506 A61B8/00 A61B8/06 A61B8/08 A61B8/4245 A61B8/485 A61B18/14 A61B18/18 A61B90/37 A61B2017/320069 A61B2018/00404 A61B2018/00434 A61B2018/00511 A61B2090/374 A61B2090/3762 A61B2090/378 A61N1/0551 A61N5/00 A61N5/0601 A61N5/062 A61N5/0622 A61N7/00 A61N7/02 A61N2005/063 A61N2007/0026 A61N2007/003 A61N2007/0078		
优先权	61/250857 2009-10-12 US 61/256983 2009-10-31 US 61/261741 2009-11-16 US 61/291359 2009-12-30 US 12/685655 2010-01-11 US 61/303307 2010-02-10 US 12/725450 2010-03-16 US 61/347375 2010-05-21 US 61/377908 2010-08-27 US		
其他公开文献	EP2488250B1 EP2488250A4		
外部链接	Espacenet		

摘要(译)

在一些实例中，围绕动脉或导致器官的神经被能量源靶向以校正或调节生理过程。在一些示例中，不同类型的能量源被单独使用或彼此组合使用。在一些实例中，由能量源激活的生物活性剂或装置被递送至感兴趣的区域，并且通过这些试剂增强能量，或者通过能量源增强试剂。