

(19) World Intellectual Property Organization
International Bureau



(43) International Publication Date
13 November 2008 (13.11.2008)

PCT

(10) International Publication Number
WO 2008/137579 A1

- (51) International Patent Classification:
A61B 5/00 (2006.01)
- (21) International Application Number:
PCT/US2008/062273
- (22) International Filing Date: 1 May 2008 (01.05.2008)
- (25) Filing Language: English
- (26) Publication Language: English
- (30) Priority Data:
60/915,161 1 May 2007 (01.05.2007) US
- (71) Applicant (for all designated States except US): **NEURO-FOCUS, INC.** [US/US]; 1200 5th Street, Berkeley, California 94710 (US).
- (72) Inventors; and
- (75) Inventors/Applicants (for US only): **PRADEEP, Anantha** [US/US]; 1200 5th Street, Berkeley, California 94710 (US). **KNIGHT, Robert, T.** [US/US]; 1200 5th Street, Berkeley, California 94710 (US). **GURUMOORTHY, Ramachandran** [US/US]; 1200 5th Street, Berkeley, California 94710 (US).

- (74) Agents: **KWAN, Godfrey, Audrey** et al.; Weaver Austin Villeneuve & Sampson LLP, P. O. Box 70250, Oakland, California 94612-0250 (US).
- (81) Designated States (unless otherwise indicated, for every kind of national protection available): AE, AG, AL, AM, AO, AT, AU, AZ, BA, BB, BG, BH, BR, BW, BY, BZ, CA, CH, CN, CO, CR, CU, CZ, DE, DK, DM, DO, DZ, EC, EE, EG, ES, FI, GB, GD, GE, GH, GM, GT, HN, HR, HU, ID, IL, IN, IS, JP, KE, KG, KM, KN, KP, KR, KZ, LA, LC, LK, LR, LS, LT, LU, LY, MA, MD, ME, MG, MK, MN, MW, MX, MY, MZ, NA, NG, NI, NO, NZ, OM, PG, PH, PL, PT, RO, RS, RU, SC, SD, SE, SG, SK, SL, SM, SV, SY, TJ, TM, TN, TR, TT, TZ, UA, UG, US, UZ, VC, VN, ZA, ZM, ZW.
- (84) Designated States (unless otherwise indicated, for every kind of regional protection available): ARIPO (BW, GH, GM, KE, LS, MW, MZ, NA, SD, SL, SZ, TZ, UG, ZM, ZW), Eurasian (AM, AZ, BY, KG, KZ, MD, RU, TJ, TM), European (AT, BE, BG, CH, CY, CZ, DE, DK, EE, ES, FI, FR, GB, GR, HR, HU, IE, IS, IT, LT, LU, LV, MC, MT, NL, NO, PL, PT, RO, SE, SI, SK, TR), OAPI (BF, BJ, CF, CG, CI, CM, GA, GN, GQ, GW, ML, MR, NE, SN, TD, TG).

Published:
— with international search report

[Continued on next page]

(54) Title: NEURO-INFORMATICS REPOSITORY SYSTEM

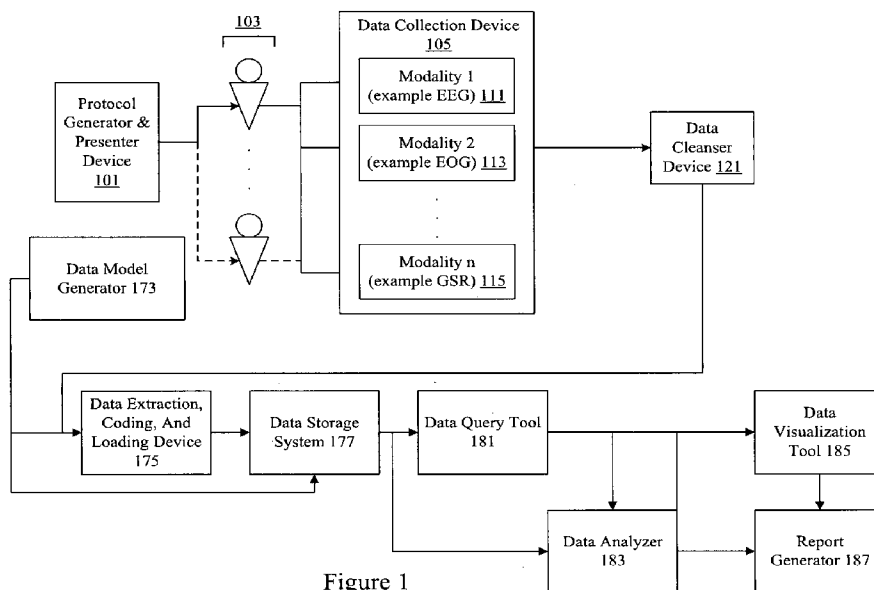

Figure 1

(57) Abstract: A neuro-informatics repository system is provided to allow efficient generation, management, and access to central nervous system, autonomic nervous system, effector data, and behavioral data obtained from subjects exposed to stimulus material. Data collected using multiple modalities such as Electroencephalography (EEG), Electrooculography (EOG), Galvanic Skin Response (GSR), Event Related Potential (ERP), surveys, etc., is stored using a variety of data models to allow efficient querying, report generation, analysis and/or visualization.

WO 2008/137579 A1



-
- *before the expiration of the time limit for amending the claims and to be republished in the event of receipt of amendments*

NEURO-INFORMATICS REPOSITORY SYSTEM

CROSS REFERENCE TO RELATED APPLICATIONS

[0001] This application claims priority to Provisional Patent Application 60/915,161 (Docket No. 2007NF3) titled Neuro-Informatics Repository System, by
5 Anantha Pradeep, Robert T. Knight, and Ramachandran Gurumoorthy, and filed on May 1, 2007.

TECHNICAL FIELD

[0002] The present disclosure relates to providing a neuro-informatics repository system.

10 DESCRIPTION OF RELATED ART

[0003] Conventional systems for managing neurological and neurophysiological data are limited or nonexistent. In some examples, marketing materials are evaluated using survey based evaluations or neurophysiological measurements taken in isolation. These conventional mechanisms provide some useful data that may be
15 suitable for particular purposes. However, the survey based evaluations or limited neurological measurements used in isolation have limited practical use, particularly when stored inefficiently in existing systems. Furthermore, the survey based evaluations or neurophysiological measurements are highly inefficient and inaccurate due to a variety of semantic, syntactic, metaphorical, cultural, social, and
20 interpretative errors and biases.

[0004] Consequently, it is desirable to provide improved methods and apparatus for generating, managing, and accessing a neuro-informatics repository system.

BRIEF DESCRIPTION OF THE DRAWINGS

[0005] The disclosure may best be understood by reference to the following
25 description taken in conjunction with the accompanying drawings, which illustrate particular example embodiments.

[0006] Figure 1 illustrates one example of a system for implementing a neuro-informatics repository system.

[0007] Figure 2 illustrates examples of data models that can be used with the neuro-
30 informatics repository system.

[0008] Figure 3 illustrates examples of queries that can be used with the neuro-informatics repository system.

[0009] Figure 4 illustrates examples of reports generated using the neuro-informatics repository system.

[0010] Figure 5 illustrates one example of a technique for generating, managing, and using a neuro-informatics repository system.

5 [0011] Figure 6 provides one example of a system that can be used to implement one or more mechanisms.

DESCRIPTION OF PARTICULAR EMBODIMENTS

[0012] Reference will now be made in detail to some specific examples of the invention including the best modes contemplated by the inventors for carrying out the
10 invention. Examples of these specific embodiments are illustrated in the accompanying drawings. While the invention is described in conjunction with these specific embodiments, it will be understood that it is not intended to limit the invention to the described embodiments. On the contrary, it is intended to cover alternatives, modifications, and equivalents as may be included within the spirit and
15 scope of the invention as defined by the appended claims.

[0013] For example, the techniques and mechanisms of the present invention will be described in the context of neuro-physiological feedback based assessment of stimuli. However, it should be noted that the techniques and mechanisms of the present invention apply to a variety of different types of data including neuro-
20 physiological, behavioral, and survey based assessments of stimuli including entertainment and marketing such as video and audio streams, media advertising, text, printed advertisements, etc. It should be noted that various mechanisms and techniques can be applied to any type of stimuli. In the following description, numerous specific details are set forth in order to provide a thorough understanding of
25 the present invention. Particular example embodiments of the present invention may be implemented without some or all of these specific details. In other instances, well known process operations have not been described in detail in order not to unnecessarily obscure the present invention.

[0014] Various techniques and mechanisms of the present invention will sometimes
30 be described in singular form for clarity. However, it should be noted that some embodiments include multiple iterations of a technique or multiple instantiations of a mechanism unless noted otherwise. For example, a system uses a processor in a variety of contexts. However, it will be appreciated that a system can use multiple

processors while remaining within the scope of the present invention unless otherwise noted. Furthermore, the techniques and mechanisms of the present invention will sometimes describe a connection between two entities. It should be noted that a connection between two entities does not necessarily mean a direct, unimpeded
5 connection, as a variety of other entities may reside between the two entities. For example, a processor may be connected to memory, but it will be appreciated that a variety of bridges and controllers may reside between the processor and memory. Consequently, a connection does not necessarily mean a direct, unimpeded connection unless otherwise noted.

10 [0015] Overview

[0016] A neuro-informatics repository system is provided to allow efficient generation, management, and access to central nervous system, autonomic nervous system, effector data, and behavioral data obtained from subjects exposed to stimulus material. Data collected using multiple modalities such as Electroencephalography
15 (EEG), Electrooculography (EOG), Galvanic Skin Response (GSR), Event Related Potential (ERP), surveys, etc., is stored using a variety of data models to allow efficient querying, report generation, analysis and/or visualization.

[0017] Example Embodiments

[0018] Conventional mechanisms for obtaining information about subject responses
20 to stimulus materials such as marketing and entertainment materials have generally relied on focus groups and surveys. Subjects are provided with oral and written mechanisms for conveying their thoughts and feelings elicited in response to a particular advertisement, brand, media clip, etc. These oral and written mechanisms provide some limited information on the effectiveness of the marketing and
25 entertainment materials, but have a variety of limitations. For example, subjects may be unable or unwilling to express their true thoughts and feelings about a topic, or questions may be phrased with built in bias. Articulate subjects may be given more weight than nonexpressive ones. A variety of semantic, syntactic, metaphorical, cultural, social and interpretive biases and errors prevent accurate and repeatable
30 evaluation.

[0019] The focus groups and survey records could then be filed and stored, but were generally used for only very particular purposes. The ability to generate, manage, and access even these limited focus group and survey records has been lacking. While

these conventional mechanisms may be suitable for the particular purpose to which they address, they are not as suitable for providing a repository for the aggregation of neurological and neuro-physiological presentations and assessments of stimulus material including marketing, entertainment, and other audio/visual/tactile/olfactory stimulus across multiple demographics

5 [0020] Consequently, the techniques and mechanisms of the present invention obtain neurological and neurophysiological measurements and store the information using a variety of data models. Some examples of central nervous system measurement mechanisms include Functional Magnetic Resonance Imaging (fMRI) and Electroencephalography (EEG). fMRI measures blood oxygenation in the brain that correlates with increased neural activity. However, current implementations of fMRI have poor temporal resolution of few seconds. EEG measures electrical activity associated with post synaptic currents occurring in the milliseconds range. Subcranial EEG can measure electrical activity with the most accuracy, as the bone and dermal layers weaken transmission of a wide range of frequencies. Nonetheless, surface EEG provides a wealth of electrophysiological information if analyzed properly.

10 [0021] Autonomic nervous system measurement mechanisms include Galvanic Skin Response (GSR), Electrocardiograms (EKG), pupillary dilation, etc. Effector measurement mechanisms include Electrooculography (EOG), eye tracking, facial emotion encoding, reaction time etc.

15 [0022] According to various embodiments, the techniques and mechanisms of the present invention intelligently blend multiple modes and manifestations of precognitive neural signatures with cognitive neural signatures and post cognitive neurophysiological manifestations to more accurately allow assessment of stimulus material. In some examples, autonomic nervous system measures are themselves used to validate central nervous system measures. Effector and behavior responses are blended and combined with other measures. According to various embodiments, central nervous system, autonomic nervous system, and effector system measurements are aggregated into a neuro-feedback significance measurement that is also associated with stimulus material such as a media stream, and stored. This stored information can be used to automatically compress the media stream using an analyzer and visualization tool.

[0023] In particular embodiments, neurological and neuro-physiological information is generated and stored using data models to allow efficient querying, report generation and visualization. In some examples, portions of media streams having particular component assessment measures like attention and emotional engagement scores are queried for review. In other examples, industry, category, and client specific percentiles for marketing campaigns may be automatically retrieved for review. In still other examples, location and demographic parameters combined with engagement scores may be used to select materials for visualization or report generation.

10 [0024] A variety of stimulus materials such as entertainment and marketing materials, media streams, billboards, print advertisements, text streams, music, performances, sensory experiences, etc. may be digitized and stored with parameters and neurological and neuro-physiological response data.

[0025] According to various embodiments, a neuro-informatics repository system stores neurological and neuro-physiological data generated using a neuro-feedback analyzer that performs both intra-modality measurement enhancements and cross-modality measurement enhancements. According to various embodiments, brain activity is measured not just to determine the regions of activity, but to determine interactions and types of interactions between various regions. The techniques and mechanisms of the present invention recognize that interactions between neural regions support orchestrated and organized behavior. Attention, emotion, memory, and other abilities are not merely based on one part of the brain but instead rely on network interactions between brain regions.

20 [0026] The techniques and mechanisms of the present invention further recognize that different frequency bands used for multi-regional communication can be indicative of the effectiveness of stimuli. In particular embodiments, evaluations are calibrated to each subject and synchronized across subjects. In particular embodiments, templates are created for subjects to create a baseline for measuring pre and post stimulus differentials. According to various embodiments, stimulus generators are intelligent, and adaptively modify specific parameters such as exposure length and duration for each subject being analyzed. An intelligent stimulus generation mechanism intelligently adapts output for particular users and purposes. A variety of modalities can be used including EEG, GSR, EKG, pupillary dilation,

EOG, eye tracking, facial emotion encoding, reaction time, etc. Individual modalities such as EEG are enhanced by intelligently recognizing neural region communication pathways. Cross modality analysis is enhanced using a synthesis and analytical blending of central nervous system, autonomic nervous system, and effector signatures. Synthesis and analysis by mechanisms such as time and phase shifting, correlating, and validating intra-modal determinations allow generation of a composite output that can be stored, managed, and manipulated in a neuro-informatics repository system.

[0027] Figure 1 illustrates one example of a system for using neuro-feedback significance measures determined with central nervous system, autonomic nervous system, and effector measures. According to various embodiments, the neuro-informatics repository system includes a protocol generator and presenter device 101. In particular embodiments, the protocol generator and presenter device 101 is merely a presenter device and merely presents stimulus material to a user. The stimuli may be a media clip, a commercial, pages of text, a brand image, a performance, a magazine advertisement, a movie, an audio presentation, particular tastes, smells, textures and/or sounds. The stimuli can involve a variety of senses and occur with or without human supervision. Continuous and discrete modes are supported. According to various embodiments, the protocol generator and presenter device 101 also has protocol generation capability to allow intelligent customization of stimuli provided to a subject.

[0028] According to various embodiments, the subjects are connected to data collection devices 105. The data collection devices 105 may include a variety of neurological and neurophysiological measurement mechanisms such as EEG, EOG, GSR, EKG, pupillary dilation, eye tracking, facial emotion encoding, and reaction time devices, etc. In particular embodiments, the data collection devices 105 include EEG 111, EOG 113, and GSR 115. In some instances, only a single data collection device is used. Data collection may proceed with or without human supervision.

[0029] The data collection device 105 collects neuro-physiological data from multiple sources. This includes a combination of devices such as central nervous system sources (EEG), autonomic nervous system sources (GSR, EKG, pupillary dilation), and effector sources (EOG, eye tracking, facial emotion encoding, reaction time). In particular embodiments, data collected is digitally sampled and stored for

later analysis. In particular embodiments, the data collected could be analyzed in real-time. According to particular embodiments, the digital sampling rates are adaptively chosen based on the neurophysiological and neurological data being measured.

[0030] In one particular embodiment, the neuro-informatics repository system
5 stores data that includes EEG 111 measurements made using scalp level electrodes, EOG 113 measurements made using shielded electrodes to track eye data, GSR 115 measurements performed using a differential measurement system, a facial muscular measurement through shielded electrodes placed at specific locations on the face, and a facial affect graphic and video analyzer adaptively derived for each individual. In
10 particular embodiments, the data collection includes behavioral responses and survey responses from individuals.

[0031] In particular embodiments, the data collection devices are clock
synchronized with a protocol generator and presenter device 101. The data collection
system 105 can collect data from a single individual (1 system), or can be modified to
15 collect synchronized data from multiple individuals (N+1 system). The N+1 system
may include multiple individuals synchronously tested in isolation or in a group
setting. In particular embodiments, the data collection devices also include a
condition evaluation subsystem that provides auto triggers, alerts and status
monitoring and visualization components that continuously monitor the status of the
20 subject, data being collected, and the data collection instruments. The condition
evaluation subsystem may also present visual alerts and automatically trigger
remedial actions. In particular embodiments, the data collection devices could be
external to the repository system that just provide a source of neuro-physiological and
behavioral data to be stored, analyzed, queried, visualized, and reported in the neuro-
25 informatics repository system.

[0032] According to various embodiments, the neuro-informatics repository system
also includes a data cleanser device 121. In particular embodiments, the data cleanser
device 121 filters the collected data to remove noise, artifacts, and other irrelevant
data using fixed and adaptive filtering, weighted averaging, advanced component
30 extraction (like PCA, ICA), vector and component separation methods, etc. This
device cleanses the data by removing both exogenous noise (where the source is
outside the physiology of the subject) and endogenous artifacts (where the source

could be neurophysiological like muscle movement, eye blinks, etc.). The cleansed data is stored in the neuro-informatics repository storage system.

[0033] The artifact removal subsystem includes mechanisms to selectively isolate and review the response data and identify epochs with time domain and/or frequency domain attributes that correspond to artifacts such as line frequency, eye blinks, and muscle movements. The artifact removal subsystem then cleanses the artifacts by either omitting these epochs, or by replacing these epoch data with an estimate based on the other clean data (for example, an EEG nearest neighbor weighted averaging approach).

10 [0034] According to various embodiments, the data cleanser device 121 is implemented using hardware, firmware, and/or software. It should be noted that although a data cleanser device 121 is shown located after a data collection device 105, the data cleanser device 121 like other components may have a location and functionality that varies based on system implementation. For example, some systems may not use any automated data cleanser device whatsoever. In other systems, data cleanser devices may be integrated into individual data collection devices. In other systems, the data cleanser devices could be external to the repository system and provide cleansed data for storage, analysis, and management in the repository system.

20 [0035] According to various embodiments, a data model generator 173 generates and/or enhances the data models used for the storage, querying, analyzing, viewing and reporting of marketing, advertising and other audio/visual/tactile/olfactory stimuli and effectiveness measures or sub-measures. In particular embodiments, the model generator device includes mechanisms to define, modify, and develop data models for recording and describing the attributes of a particular dataset and/or experiment, data models for describing and recording the demography attributes of the subjects included, data models for collating the neuro-physiological and neuro-behavioral assessment mechanism included, data models for collecting the neuro-physiological and neuro-behavioral assessment data and measures, data models for defining and recording pre-set queries into the underlying repository data or data models, data models for generating custom queries into the underlying repository data or data models, data models for specifying data visualizations and data analyses of the

underlying data, and data models for the specification of reports to be generated and the formats required

[0036] The data model generator 173 is connected to a data extraction, coding, and loading device 175. According to various embodiments, the data extraction, coding, and loading device performs extraction of different neuro-physiological and neuro-behavioral response parameters including the original signals, customizes coding of the component and parameters as appropriate to the signals being used, and loads data into the repository system as well as exports data from the repository system.

[0037] The mechanisms allow for the identification of response parameters, time-domain and frequency domain evaluation, extraction of relevant information from the signals, and custom transfer of data into and out of the repository system. It should be noted that various components can be implemented using hardware, firmware, and/or software.

[0038] According to various embodiments, both the data model generator 173 and the data extraction, coding, and loading device 175 are connected to data storage system 177 that allows custom storage and archival of data with attributes. In particular embodiments, the data storage system 177 uses a database such as a relational, object oriented, or hierarchical database, or a flat file system that allows management and retrieval of neurological, neuro-physiological data, and behavioral data. The physical devices for storage may include tape drives, redundant arrays of independent disks (RAIDs), optical drives, flash memory, or other persistent forms of data storage.

[0039] According to various embodiments, the data stored in the data storage system 177 includes the raw data along with metadata and model attributes, as well as other synthesized/morphed forms of the data to allow for efficient access for querying, analysis, export, visualization, and report generation. In particular embodiments, the data also includes the collected neurological and neuro-physiological data from subject responses. The analyzed and synthesized response measures (optionally including the survey responses) could also be stored. In some instances, the stimulus material itself is also stored. The data could be stored internally in a secure, compartmentalized fashion or could be stored in an open or intermingled manner.

[0040] A data query tool 181 allows efficient and effective access to data in data storage system 177. According to various embodiments, the data query tool 181 presents preset or custom queries for data in data storage system 177 including queries based on general or customized scripting languages and constructs, visual
5 querying techniques, diagnostic querying including drill-down diagnostics, and scenario queries. The queries execution could be user or system initiated, or could be automated by schedule or could be based on internal/external triggers. The data analyzer 183 can also obtain data from either data storage system 177 or data query tool 181.

10 [0041] According to various embodiments, the data analyzer is a suite of mechanisms provided to analyze the underlying data in the system to identify responses and gain insights. In particular embodiments, neuro-physiological and neuro-behavioral signatures are determined based on time domain analyses and frequency domain analyses. Such analyses use the parameters that are common
15 across the datasets and individuals, as well as parameters that are unique. In particular embodiments, the analyses include statistical parameter extraction and fuzzy logic based attribute estimation from both the time and frequency components of the synthesized response. The statistical parameters used in the blended effectiveness estimates include estimates of skew, peaks, first and second moments of
20 the data, population distribution characteristics, attention, emotional engagement and memory retention. The analyses could also include assessing response measures.

[0042] According to various embodiments, the data analyzer 183 may also be associated with an intra-modality response synthesizer and a cross-modality response synthesizer. In particular embodiments, the intra-modality response synthesizer is
25 configured to customize and extract the independent neurological and neurophysiological parameters for each individual in each modality and blend the estimates within a modality analytically to elicit an enhanced response to the presented stimuli. In particular embodiments, the intra-modality response synthesizer also aggregates data from different subjects in a dataset.

30 [0043] According to various embodiments, the cross-modality response synthesizer or fusion device blends different intra-modality responses, including raw signals and signals output. The combination of signals enhances the measures of effectiveness

within a modality. The cross-modality response fusion device can also aggregate data from different subjects in a dataset.

[0044] According to various embodiments, the data analyzer 183 also includes a composite enhanced effectiveness estimator (CEEE) that combines the enhanced responses and estimates from each modality to provide a blended estimate of the neuro-feedback significance. In particular embodiments, results and measures of the data analyzer are stored in the repository storage system 177.

[0045] According to various embodiments, the data visualization tool 185 allows for visualization of the data in multiple ways for different purposes and audiences. In particular embodiments, the visualizations include graphics and/or text. The tool provides options for formats of visualization, samples of visualizations, and mechanisms for implementing combinations of visualization formats. According to various embodiments, the data visualization tool 185 also allows a user to define new visualizations and formats, store and manage generated visualizations, and export the visualizations in one or more formats. In some examples, these visualizations include conversion/compression of the original stimulus for various purposes. In some instances, visualization may include audio or other sensory affects.

[0046] A report generator 187 allows for the generation of customized reports in multiple formats using the underlying data views, analyzes, insights, and/or visualizations for a variety of purposes and audiences. The report generator 187 supports both preset reports and custom reports and allows a user to specify the data and inferences to be included, the theme of the report, any additional external material for inclusion, and the format required for the report. The reports generation/presentation could be based on pull (user or other system/sub-system initiated) or push (automatic schedules, threshold triggers, etc.) techniques. In some examples, a neuro-informatics repository system is separate from a visualization tool 185 and a report generator 187. For example, a repository system may be server based while a visualization tool 185 and a report generator 187 are remote client.

[0047] Figure 2 illustrates examples of data models that can be used with a neuro-informatics repository system. According to various embodiments, a dataset data model 201 includes an experiment name 203 and/or identifier, client attributes 205, a subject pool 207, logistics information 209 such as the location, date, and time of testing, and stimulus material 211 including stimulus material attributes.

[0048] In particular embodiments, a subject attribute data model 215 includes a subject name 217 and/or identifier, contact information 221, and demographic attributes 219 that may be useful for review of neurological and neuro-physiological data. Some examples of pertinent demographic attributes include marriage status, 5 employment status, occupation, household income, household size and composition, ethnicity, geographic location, sex, race. Other fields that may be included in data model 215 include shopping preferences, entertainment preferences, and financial preferences. Shopping preferences include favorite stores, shopping frequency, categories shopped, favorite brands. Entertainment preferences include 10 network/cable/satellite access capabilities, favorite shows, favorite genres, and favorite actors. Financial preferences include favorite insurance companies, preferred investment practices, banking preferences, and favorite online financial instruments. A variety of subject attributes may be included in a subject attributes data model 215 and data models may be preset or custom generated to suit particular purposes.

[0049] According to various embodiments, data models for neuro-feedback association 225 identify experimental protocols 227, modalities included 229 such as EEG, EOG, GSR, surveys conducted, and experiment design parameters 233 such as segments and segment attributes. Other fields may include experiment presentation scripts, segment length, segment details like stimulus material used, inter-subject 20 variations, intra-subject variations, instructions, presentation order, survey questions used, etc. Other data models may include a data collection data model 237. According to various embodiments, the data collection data model 237 includes recording attributes 239 such as station and location identifiers, the data and time of recording, and operator details. In particular embodiments, equipment attributes 241 25 include an amplifier identifier and a sensor identifier.

[0050] Modalities recorded 243 may include modality specific attributes like EEG cap layout, active channels, sampling frequency, and filters used. EOG specific attributes include the number and type of sensors used, location of sensors applied, etc. Eye tracking specific attributes include the type of tracker used, data recording 30 frequency, data being recorded, recording format, etc. According to various embodiments, data storage attributes 245 include file storage conventions (format, naming convention, dating convention), storage location, archival attributes, expiry attributes, etc.

[0051] A preset query data model 249 includes a query name 251 and/or identifier, an accessed data collection 253 such as data segments involved (models, databases/cubes, tables, etc.), access security attributes 255 included who has what type of access, and refresh attributes 257 such as the expiry of the query, refresh
5 frequency, etc. Other fields such as push-pull preferences can also be included to identify an auto push reporting driver or a user driven report retrieval system.

[0052] Figure 3 illustrates examples of queries that can be performed on a neuro-informatics repository system. According to various embodiments, queries are defined from general or customized scripting languages and constructs, visual
10 mechanisms, a library of preset queries, diagnostic querying including drill-down diagnostics, and eliciting what if scenarios. According to various embodiments, subject attributes queries 315 may be configured to obtain data from a neuro-informatics repository using a location 317 or geographic information, session information 321 such as testing times and dates, and demographic attributes 319.
15 Demographics attributes include household income, household size and status, education level, age of kids, etc.

[0053] Other queries may retrieve stimulus material based on shopping preferences of subject participants, countenance, physiological assessment, completion status. For example, a user may query for data associated with product categories, products
20 shopped, shops frequented, subject eye correction status, color blindness, subject state, signal strength of measured responses, alpha frequency band ringers, muscle movement assessments, segments completed, etc. Experimental design based queries may obtain data from a neuro-informatics repository based on experiment protocols 327, product category 329, surveys included 331, and stimulus provided 333. Other
25 fields that may be used include the number of protocol repetitions used, combination of protocols used, and usage configuration of surveys.

[0054] Client and industry based queries may obtain data based on the types of industries included in testing, specific categories tested, client companies involved, and brands being tested. Response assessment based queries 337 may include
30 attention scores 339, emotion scores, 341, retention scores 343, and effectiveness scores 345. Such queries may obtain materials that elicited particular scores.

[0055] Response measure profile based queries may use mean measure thresholds, variance measures, number of peaks detected, etc. Group response queries may

include group statistics like mean, variance, kurtosis, p-value, etc., group size, and outlier assessment measures. Still other queries may involve testing attributes like test location, time period, test repetition count, test station, and test operator fields. A variety of types and combinations of types of queries can be used to efficiently extract
5 data from a neuro-informatics repository.

[0056] Figure 4 illustrates examples of reports that can be generated. According to various embodiments, client assessment summary reports 401 include effectiveness measures 403, component assessment measures 405, and habituation measures 407. Effectiveness assessment measures include composite assessment measure(s),
10 industry/category/client specific placement (percentile, ranking, ...), actionable grouping assessment such as removing material, modifying segments, or fine tuning specific elements, etc, and the evolution of the effectiveness profile over time. In particular embodiments, component assessment reports include component assessment measures like attention, emotional engagement scores, percentile
15 placement, ranking, etc. Component profile measures include time based evolution of the component measures and profile statistical assessments. According to various embodiments, habituation and wear out reports include the number of times material is assessed, attributes of the multiple presentations used, evolution of the response assessment measures over the multiple presentations, and usage recommendations
20 based on the habituation characteristics.

[0057] According to various embodiments, client cumulative reports 411 include media grouped reporting 413 of all stimulus assessed, campaign grouped reporting 415 of stimulus assessed, and time/location grouped reporting 417 of stimulus assessed. According to various embodiments, industry cumulative and syndicated
25 reports 421 include aggregate assessment responses measures 423, top performer lists 425, bottom performer lists 427, outliers 429, and trend reporting 431. In particular embodiments, tracking and reporting includes specific products, categories, companies, brands.

[0058] A variety of mechanisms can be used to develop and store assessment
30 response measures. In particular embodiments, EEG response data is synthesized to provide an enhanced assessment of neuro-feedback significance. According to various embodiments, EEG measures electrical activity resulting from thousands of simultaneous neural processes associated with different portions of the brain. EEG

data can be classified in various bands. According to various embodiments, brainwave frequencies include delta, theta, alpha, beta, and gamma frequency ranges. Delta waves are classified as those less than 4 Hz and are prominent during deep sleep. Theta waves have frequencies between 3.5 to 7.5 Hz and are associated with
5 memories, attention, emotions, and sensations. Theta waves are typically prominent during states of internal focus.

[0059] Alpha frequencies reside between 7.5 and 13Hz and typically peak around 10Hz. Alpha waves are prominent during states of relaxation. Beta waves have a frequency range between 14 and 30Hz. Beta waves are prominent during states of
10 motor control, long range synchronization between brain areas, analytical problem solving, judgment, and decision making. Gamma waves occur between 30 and 60Hz and are involved in binding of different populations of neurons together into a network for the purpose of carrying out a certain cognitive or motor function, as well as in attention and memory. Because the skull and dermal layers attenuate waves in
15 this frequency range, brain waves above 75-80Hz are difficult to detect and are often not used for stimuli response assessment.

[0060] However, the techniques and mechanisms of the present invention recognize that analyzing high gamma band (kappa-band: Above 60Hz) measurements, in addition to theta, alpha, beta, and low gamma band measurements, enhances
20 neurological attention, emotional engagement and retention component estimates. In particular embodiments, EEG measurements including difficult to detect high gamma or kappa band measurements are obtained, enhanced, and evaluated. Subject and task specific signature sub-bands in the theta, alpha, beta, gamma and kappa bands are identified to provide enhanced response estimates. According to various
25 embodiments, high gamma waves (kappa-band) above 80 Hz (typically detectable with sub-cranial EEG and/or magneto encephalography) can be used in inverse model-based enhancement of the frequency responses to the stimuli.

[0061] Various embodiments of the present invention recognize that particular sub-bands within each frequency range have particular prominence during certain
30 activities. A subset of the frequencies in a particular band is referred to herein as a sub-band. For example, a sub-band may include the 40-45Hz range within the gamma band. In particular embodiments, multiple sub-bands within the different bands are selected while remaining frequencies are band pass filtered. In particular

embodiments, multiple sub-band responses may be enhanced, while the remaining frequency responses may be attenuated.

[0062] An information theory based band-weighting model is used for adaptive extraction of selective dataset specific, subject specific, task specific bands to enhance
5 the neuro-informatics repository data. Adaptive extraction may be performed using fuzzy scaling. Stimuli can be presented and enhanced measurements determined multiple times to determine the variation or habituation profiles across multiple presentations. Determining the variation and/or habituation profiles provides an enhanced assessment of the primary responses as well as the longevity (wear-out) of
10 the marketing and entertainment stimuli. The synchronous response of multiple individuals to stimuli presented in concert is measured to determine an enhanced across subject synchrony measure of effectiveness. According to various embodiments, the synchronous response may be determined for multiple subjects residing in separate locations or for multiple subjects residing in the same location.

[0063] Although a variety of synthesis mechanisms are described, it should be recognized that any number of mechanisms can be applied in sequence or in parallel with or without interaction between the mechanisms. In some examples, processes
15 321 and 327 can be applied to any modality.

[0064] Although intra-modality synthesis mechanisms provide enhanced neuro-informatics repository data, additional cross-modality synthesis mechanisms can also
20 be applied to provide enhanced assessment measures. A variety of mechanisms such as EEG, Eye Tracking, GSR, EOG, and facial emotion encoding are connected to a cross-modality synthesis mechanism. Other mechanisms as well as variations and enhancements on existing mechanisms may also be included. According to various
25 embodiments, data from a specific modality can be enhanced using data from one or more other modalities. In particular embodiments, EEG typically makes frequency measurements in different bands like alpha, beta and gamma to provide estimates of significance. However, the techniques of the present invention recognize that significance measures can be enhanced further using information from other
30 modalities.

[0065] For example, facial emotion encoding measures can be used to enhance the valence of the EEG emotional engagement measure. EOG and eye tracking saccadic measures of object entities can be used to enhance the EEG estimates of significance

including but not limited to attention, emotional engagement, and memory retention. According to various embodiments, a cross-modality synthesis mechanism performs time and phase shifting of data to allow data from different modalities to align. In some examples, it is recognized that an EEG response will often occur hundreds of
5 milliseconds before a facial emotion measurement changes. Correlations can be drawn and time and phase shifts made on an individual as well as a group basis. In other examples, saccadic eye movements may be determined as occurring before and after particular EEG responses. According to various embodiments, time corrected GSR measures are used to scale and enhance the EEG estimates of significance
10 including attention, emotional engagement and memory retention measures.

[0066] Evidence of the occurrence or non-occurrence of specific time domain difference event-related potential components (like the DERP) in specific regions correlates with subject responsiveness to specific stimulus. According to various
15 embodiments, ERP measures are enhanced using EEG time-frequency measures (ERPSP) in response to the presentation of the marketing and entertainment stimuli. Specific portions are extracted and isolated to identify ERP, DERP and ERPSP analyses to perform. In particular embodiments, an EEG frequency estimation of attention, emotion and memory retention (ERPSP) is used as a co-factor in enhancing the ERP, DERP and time-domain response analysis.

[0067] EOG measures saccades to determine the presence of attention to specific
20 objects of stimulus. Eye tracking measures the subject's gaze path, location and dwell on specific objects of stimulus. According to various embodiments, EOG and eye tracking is enhanced by measuring the presence of lambda waves (a neurophysiological index of saccade effectiveness) in the ongoing EEG in the
25 occipital and extra striate regions, triggered by the slope of saccade-onset to estimate the significance of the EOG and eye tracking measures. In particular embodiments, specific EEG signatures of activity such as slow potential shifts and measures of coherence in time-frequency responses at the Frontal Eye Field (FEF) regions that preceded saccade-onset are measured to enhance the effectiveness of the saccadic
30 activity data.

[0068] GSR typically measures the change in general arousal in response to stimulus presented. According to various embodiments, GSR is enhanced by correlating EEG/ERP responses and the GSR measurement to get an enhanced

estimate of subject engagement. The GSR latency baselines are used in constructing a time-corrected GSR response to the stimulus. The time-corrected GSR response is co-factored with the EEG measures to enhance GSR significance measures.

[0069] According to various embodiments, facial emotion encoding uses templates
5 generated by measuring facial muscle positions and movements of individuals expressing various emotions prior to the testing session. These individual specific facial emotion encoding templates are matched with the individual responses to identify subject emotional response. In particular embodiments, these facial emotion encoding measurements are enhanced by evaluating inter-hemispherical asymmetries
10 in EEG responses in specific frequency bands and measuring frequency band interactions. The techniques of the present invention recognize that not only are particular frequency bands significant in EEG responses, but particular frequency bands used for communication between particular areas of the brain are significant. Consequently, these EEG responses enhance the EMG, graphic and video based facial
15 emotion identification.

[0070] Figure 5 is a flow process diagram showing a technique for testing, assessing, storing, analyzing, visualizing, and reporting on neurophysiological and behavioral data in a neuro-informatics repository system. At 501, a protocol is generated and stimulus material is provided to one or more subjects. According to
20 various embodiments, stimulus includes streaming video, media clips, printed materials, presentations, performances, games, etc. The protocol determines the parameters surrounding the presentation of stimulus, such as the number of times shown, the duration of the exposure, sequence of exposure, segments of the stimulus to be shown, etc. Subjects may be isolated during exposure or may be presented
25 materials in a group environment with or without supervision. At 503, subject responses are collected using a variety of modalities, such as EEG, ERP, EOG, GSR, etc. In some examples, verbal and written responses can also be collected and correlated with neurological and neurophysiological responses. At 505, data is passed through a data cleanser to remove noise and artifacts that may make data more
30 difficult to interpret. According to various embodiments, the data cleanser removes EEG electrical activity associated with blinking and other endogenous/exogenous artifacts.

[0071] At 507, preset and custom data models such as dataset, subject attributes, neuro-feedback association, data collection, and preset query data models are provided. According to various embodiments, data from the data cleanser associated with various data models is provided to perform data extraction, coding, and loading
5 at 509. This allows input of data into a repository system. In particular embodiments, a data query is performed at 511 to extract data from the repository system. According to various embodiments, the queried data is analyzed at 513 for automatic generation of estimates and insights. According to various embodiments, the data is provided to a visualization tool 515 to allow visual presentation in multiple formats.
10 The data is also used to generate reports at 517. In particular embodiments, the system is used in the synthesis of the underlying data to analyze and elicit the marketing or advertising measures being sought for different purposes or audiences.

[0072] According to various embodiments, various mechanisms such as the data collection mechanisms, the data analyzer, the report generator, etc. are implemented
15 on multiple devices. However, it is also possible that the various mechanisms be implemented in hardware, firmware, and/or software in a single system. Figure 6 provides one example of a system that can be used to implement one or more mechanisms. For example, the system shown in Figure 6 may be used to implement a data cleanser device or a cross-modality responses synthesis device.

[0073] According to particular example embodiments, a system 600 suitable for
20 implementing particular embodiments of the present invention includes a processor 601, a memory 603, an interface 611, and a bus 615 (e.g., a PCI bus). When acting under the control of appropriate software or firmware, the processor 601 is responsible for such tasks such as pattern generation. Various specially configured
25 devices can also be used in place of a processor 601 or in addition to processor 601. The complete implementation can also be done in custom hardware. The interface 611 is typically configured to send and receive data packets or data segments over a network. Particular examples of interfaces the device supports include host bus adapter (HBA) interfaces, Ethernet interfaces, frame relay interfaces, cable interfaces,
30 DSL interfaces, token ring interfaces, and the like.

[0074] In addition, various very high-speed interfaces may be provided such as fast Ethernet interfaces, Gigabit Ethernet interfaces, ATM interfaces, HSSI interfaces, POS interfaces, FDDI interfaces and the like. Generally, these interfaces may include

ports appropriate for communication with the appropriate media. In some cases, they may also include an independent processor and, in some instances, volatile RAM. The independent processors may control such communications intensive tasks as data synthesis.

5 [0075] According to particular example embodiments, the system 600 uses memory 603 to store data, algorithms and program instructions. The program instructions may control the operation of an operating system and/or one or more applications, for example. The memory or memories may also be configured to store received data and process received data.

10 [0076] Because such information and program instructions may be employed to implement the systems/methods described herein, the present invention relates to tangible, machine readable media that include program instructions, state information, etc. for performing various operations described herein. Examples of machine-readable media include, but are not limited to, magnetic media such as hard disks,
15 floppy disks, and magnetic tape; optical media such as CD-ROM disks and DVDs; magneto-optical media such as optical disks; and hardware devices that are specially configured to store and perform program instructions, such as read-only memory devices (ROM) and random access memory (RAM). Examples of program instructions include both machine code, such as produced by a compiler, and files
20 containing higher level code that may be executed by the computer using an interpreter.

[0077] Although the foregoing invention has been described in some detail for purposes of clarity of understanding, it will be apparent that certain changes and modifications may be practiced within the scope of the appended claims. Therefore,
25 the present embodiments are to be considered as illustrative and not restrictive and the invention is not to be limited to the details given herein, but may be modified within the scope and equivalents of the appended claims.

CLAIMS

What is claimed is:

1. A method, comprising:
 - receiving response data from a plurality of subjects exposed to stimulus
5 material, the response data collected using a plurality of modalities, wherein the response data includes central nervous system, autonomic nervous system, and effector data;
 - storing the stimulus material and response data using a plurality of data
10 models including a subject attribute data model;
 - receiving a query for the response data;
 - performing analysis of the response data to determine the effectiveness of the stimulus material.
2. The method of claim 1, wherein the query requests the response data and the stimulus material.
- 15 3. The method of claim 1, wherein the query requests the response data and information in the subject attribute data model.
4. The method of claim 1, wherein the plurality of data models include a neuro-feedback association data model and a data collection data model.
5. The method of claim 4, wherein the plurality of data models further include
20 a preset query data model and a dataset data model.
6. The method of claim 1, wherein the data stored includes stimulus data, analysis responses, and subject and experiment information.
7. The method of claim 1, wherein performing analysis of the response data comprises performing intra-modality synthesis and cross-modality synthesis.
- 25 8. The method of claim 1, wherein the query is a subject attribute query.
9. The method of claim 1, wherein the query is a response assessment query.
10. The method of claim 1, wherein the response data and/or raw data is provided to a report generator.
11. The method of claim 10, wherein a client assessment summary report is
30 generated using the response data.
12. The method of claim 10, wherein a client cumulative report is generated using the response data.

13. The method of claim 10, wherein a response assessment report is generated using the response data.

14. The method of claim 1, wherein the response data and/or raw data is provided to a visualization tool.

5 15. The method of claim 14, wherein the visualizations from the visualization tool are provided to a report generator.

16. The method of claim 1, wherein the effectiveness of the stimulus material is determined neurological and neurophysiological measurements including attention, emotion, and memory retention.

10 17. The method of claim 1, wherein cross-modality synthesis comprises aligning and combining response data from a first modality with response data from a second modality.

18. The method of claim 1, wherein aligning response data from a first data with response data from a second modality comprises time and phase shifting.

15 19. The method of claim 1, wherein the plurality of modalities include Electroencephalography (EEG), Electrooculography (EOG), and Galvanic Skin Response (GSR).

20. A system, comprising:

20 an interface operable to receive response data from a plurality of subjects exposed to stimulus material, the response data collected using a plurality of modalities, wherein the response data includes central nervous system, autonomic nervous system, and effector data, wherein the interface is further operable to receive a query for the response data;

25 storage operable to hold the stimulus material and response data using a plurality of data models including a subject attribute data model;

 a processor operable to perform analysis of the response data to determine the effectiveness of the stimulus material.

21. The system of claim 20, wherein the query requests the response data and the stimulus material.

30 22. The system of claim 20, wherein the query requests the response data and information in the subject attribute data model.

23. The system of claim 20, wherein the plurality of data models include a neuro-feedback association data model and a data collection data model.

24. An apparatus, comprising:

means for receiving response data from a plurality of subjects exposed to stimulus material, the response data collected using a plurality of modalities, wherein the response data includes central nervous system, autonomic nervous system, and
5 effector data;

means for storing the stimulus material and response data using a plurality of data models including a subject attribute data model;

means for receiving a query for the response data;

means for performing analysis of the response data to determine the
10 effectiveness of the stimulus material.

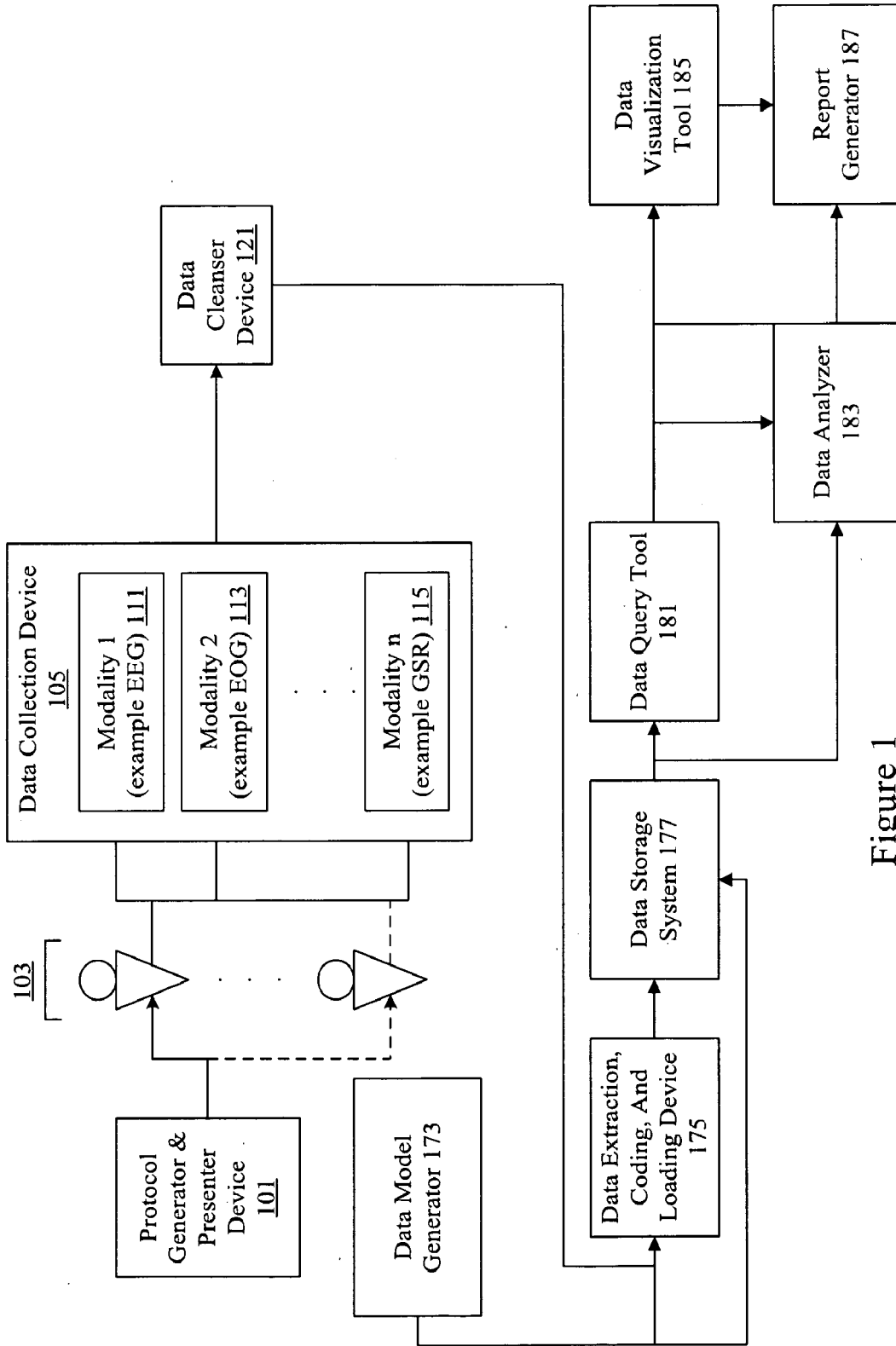

Figure 1

Dataset Data Model 201			
Experiment Name 203	Client Attributes 205	Subject Pool 207	Logistics Information 209
			Stimulus Material 211
			...
Subject Attributes Data Model 215			
Subject Name 217	Demographic Attributes 219	Contact Information 221	...
Neuro-Feedback Association Data Model 225			
Experiment Protocols 227	Modalities included 229	Experiment Design Parameters 233	...
Data Collection Data Model 237			
Recording Attributes 239	Equipment Attributes 241	Recorded 243	Data Storage Attributes 245
			...
Preset Query Data Model 249			
Query Name 251	Accessed Data Collection 253	Access Security Attributes 255	Refresh Attributes 257
			...

Figure 2

Subject Attributes Queries 315		
Location 317	Demographic Attributes 319	Session Information 321
		...

Experimental Design Queries 325		
Experiment Protocols 327	Product Category 329	Surveys Included 331
		Stimulus Used 333
		...

Response Assessment Queries 337		
Attention Score 339	Emotion Score 341	Retention Score 343
		Effectiveness Score 345
		...

Figure 3

Client Assessment Summary Reports 401			
Effectiveness 403	Component Assessment 405	Habituation 407	...
Client Cumulative Reports 411			
Media Grouped 413	Campaign Grouped 415	Time/Location Grouped 417	...
Industry Cumulative And Syndicated Reports 421			
Aggregate Assessment 423	Top Performers 425	Bottom Performers 427	Outliers 429 Trend 431 ...

Figure 4

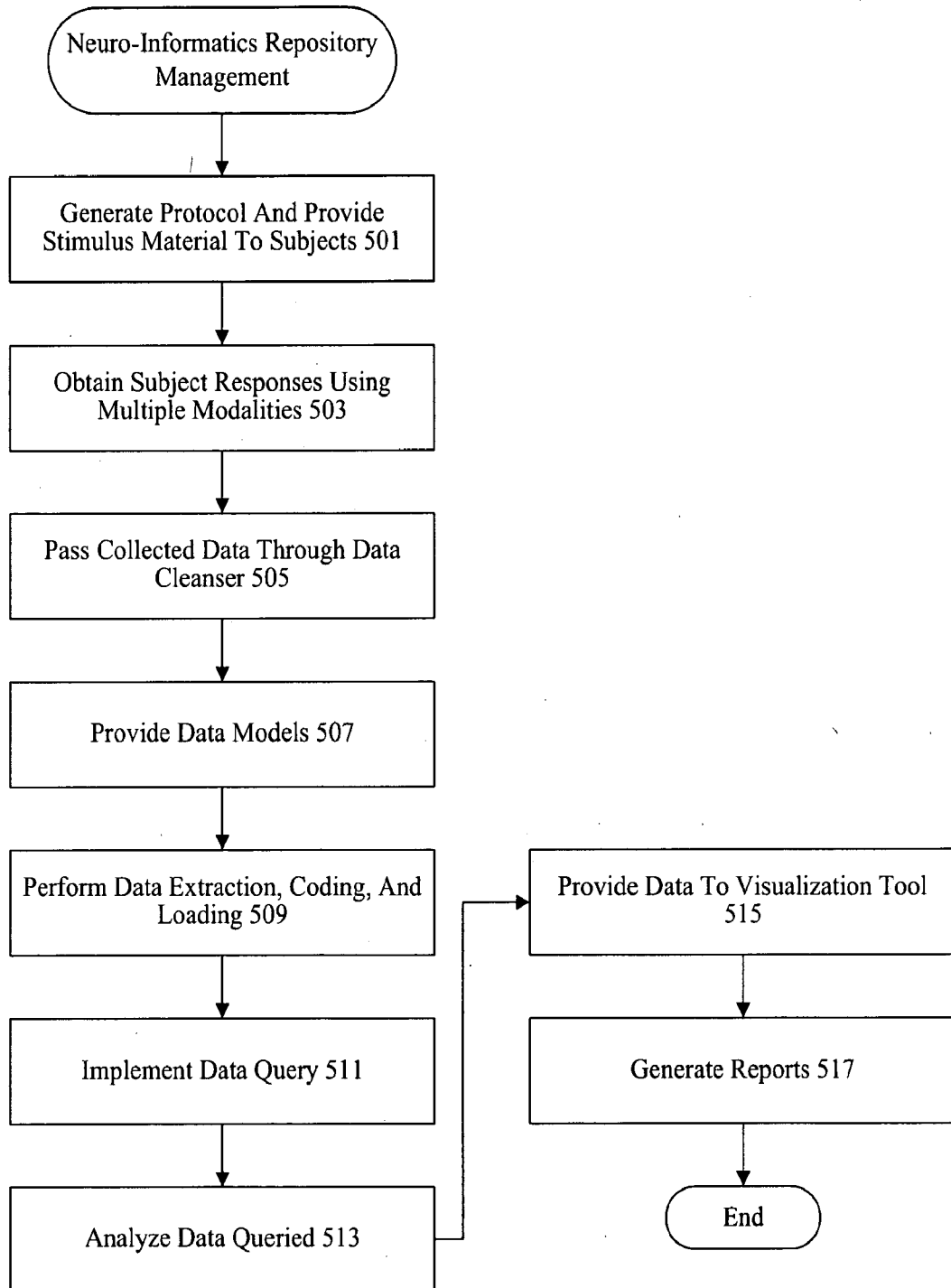

Figure 5

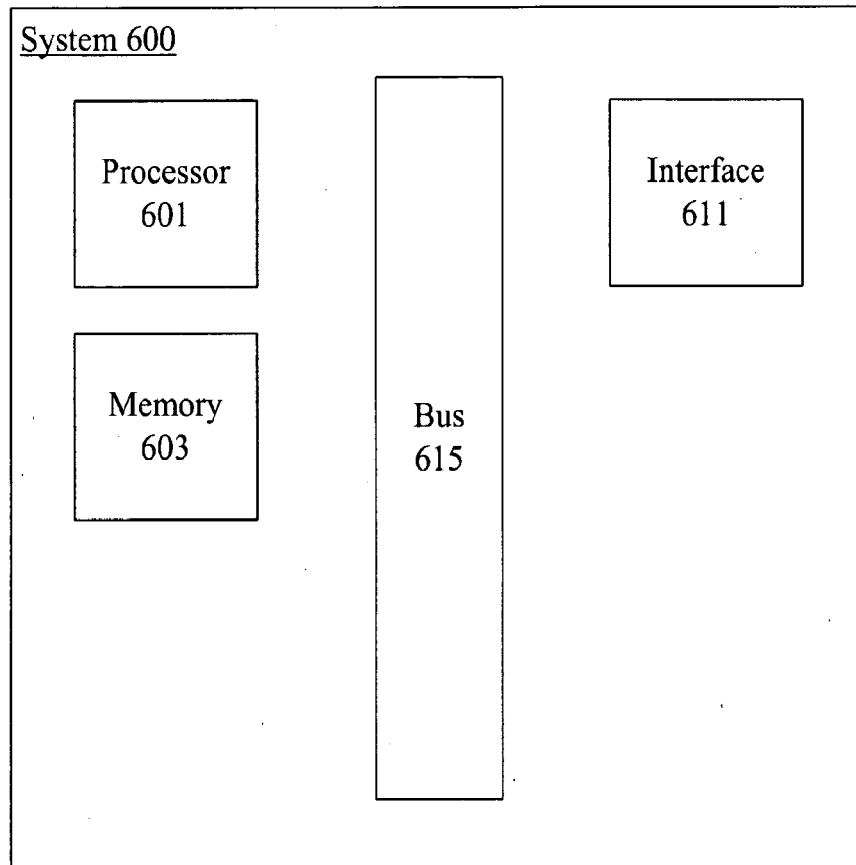

Figure 6

INTERNATIONAL SEARCH REPORT

International application No.
PCT/US 08/62273

A. CLASSIFICATION OF SUBJECT MATTER
IPC(8) - A61B 5/00 (2008.04)
USPC - 600/300
According to International Patent Classification (IPC) or to both national classification and IPC

B. FIELDS SEARCHED

Minimum documentation searched (classification system followed by classification symbols)
IPC: A61B 5/00 (2008.04)
USPC: 600/300

Documentation searched other than minimum documentation to the extent that such documents are included in the fields searched
600/ 407, 408, 382; 435/368; 706/15, 45

Electronic data base consulted during the international search (name of data base and, where practicable, search terms used)
PubWes(PGPB,USPT,EPAB,JPAB); Google Patents, Google Scholar, Google
Search Terms: Response, data, stimulus, central, autonomic, nervous, analysis, effector

C. DOCUMENTS CONSIDERED TO BE RELEVANT

Category*	Citation of document, with indication, where appropriate, of the relevant passages	Relevant to claim No.
Y	US 2007/0066874 A1 (Cook) 22 March 2007 (22.03.2007), entire document, entire document abstract, Fig 1-3 and 5, and para [0005]-[00 31]	1-24
Y	US 6,662,052 B1 (Sarwal et al), 9 December 2003 (09.12.2003), entire document, especially Fig 23, col 4, ln 46-col 5, ln 6 and col 10, ln 36-40	1-24
A	US 2005/0143629 A1 (Farwell) 30 June 2005 (30.06.2005), entire document	1-24

Further documents are listed in the continuation of Box C.

* Special categories of cited documents:
 "A" document defining the general state of the art which is not considered to be of particular relevance
 "E" earlier application or patent but published on or after the international filing date
 "I" document which may throw doubts on priority claim(s) or which is cited to establish the publication date of another citation or other special reason (as specified)
 "O" document referring to an oral disclosure, use, exhibition or other means
 "P" document published prior to the international filing date but later than the priority date claimed
 "T" later document published after the international filing date or priority date and not in conflict with the application but cited to understand the principle or theory underlying the invention
 "X" document of particular relevance; the claimed invention cannot be considered novel or cannot be considered to involve an inventive step when the document is taken alone
 "Y" document of particular relevance; the claimed invention cannot be considered to involve an inventive step when the document is combined with one or more other such documents, such combination being obvious to a person skilled in the art
 "&" document member of the same patent family

Date of the actual completion of the international search 1 September 2008 (01.09.2008)	Date of mailing of the international search report SEPTEMBER 5, 2008
--	---

Name and mailing address of the ISA/US Mail Stop PCT, Attn: ISA/US, Commissioner for Patents P.O. Box 1450, Alexandria, Virginia 22313-1450 Facsimile No. 571-273-3201	Authorized officer: Lee W. Young PCT Helpdesk: 571-272-4300 PCT OSP: 571-272-7774
---	--

专利名称(译)	神经信息库系统		
公开(公告)号	EP2142082A4	公开(公告)日	2015-10-28
申请号	EP2008747389	申请日	2008-05-01
申请(专利权)人(译)	NeuroFocus的 , INC.		
当前申请(专利权)人(译)	NeuroFocus的 , INC.		
[标]发明人	PRADEEP ANANTHA KNIGHT ROBERT T GURUMOORTHY RAMACHANDRAN		
发明人	PRADEEP, ANANTHA KNIGHT, ROBERT, T. GURUMOORTHY, RAMACHANDRAN		
IPC分类号	A61B5/00 G06F19/00		
CPC分类号	A61B5/04001 A61B5/0432 A61B5/0482 G16H15/00 G16H50/50		
优先权	60/915161 2007-05-01 US		
其他公开文献	EP2142082A1		
外部链接	Espacenet		

摘要(译)

提供神经信息库系统以允许有效地生成，管理和访问中枢神经系统，自主神经系统，效应器数据和从暴露于刺激材料的受试者获得的行为数据。使用多种模态收集的数据，如脑电图（EEG），电子血管造影（EOG），电流皮肤反应（GSR），事件相关电位（ERP），调查等，使用各种数据模型进行存储，以便进行有效的查询，报告生成，分析和/或可视化。