

(19) World Intellectual Property
Organization
International Bureau



(43) International Publication Date
8 July 2004 (08.07.2004)

PCT

(10) International Publication Number
WO 2004/057313 A1

- (51) International Patent Classification⁷: G01N 21/05, (74) Agent: BERGLUND, Erik; Berglunds Patentbyrå AB, Aspebråten, S-590 55 Sturefors (SE).
- (21) International Application Number: PCT/SE2003/002013
- (22) International Filing Date: 18 December 2003 (18.12.2003)
- (25) Filing Language: English
- (26) Publication Language: English
- (30) Priority Data:
0203868-5 20 December 2002 (20.12.2002) SE
0203869-3 20 December 2002 (20.12.2002) SE
- (71) Applicant (for all designated States except US): OPTOQ AB [SE/SE]; Berzelius Science Park, S-582 25 Linköping (SE).
- (72) Inventors; and
- (75) Inventors/Applicants (for US only): PETERSON, Magnus [SE/SE]; Kärrvägen 7, S-589 41 Linköping (SE). DAHLSTRÖM, Anna [SE/SE]; Ekkällegatan 18, S-582 30 Linköping (SE). PETERSON, Hans [SE/SE]; Brunörtsvägen 9, S-590 62 Linghem (SE).
- (81) Designated States (national): AE, AG, AL, AM, AT, AU, AZ, BA, BB, BG, BR, BY, BZ, CA, CH, CN, CO, CR, CU, CZ, DE, DK, DM, DZ, EC, EE, ES, FI, GB, GD, GE, GH, GM, HR, HU, ID, IL, IN, IS, JP, KE, KG, KP, KR, KZ, LC, LK, LR, LS, LT, LU, LV, MA, MD, MG, MK, MN, MW, MX, MZ, NI, NO, NZ, OM, PG, PH, PL, PT, RO, RU, SC, SD, SE, SG, SK, SL, SY, TJ, TM, TN, TR, TT, TZ, UA, UG, US, UZ, VC, VN, YU, ZA, ZM, ZW.
- (84) Designated States (regional): ARIPO patent (BW, GH, GM, KE, LS, MW, MZ, SD, SL, SZ, TZ, UG, ZM, ZW), Eurasian patent (AM, AZ, BY, KG, KZ, MD, RU, TJ, TM), European patent (AT, BE, BG, CH, CY, CZ, DE, DK, EE, ES, FI, FR, GB, GR, HU, IE, IT, LU, MC, NL, PT, RO, SE, SI, SK, TR), OAPI patent (BF, BJ, CF, CG, CI, CM, GA, GN, GQ, GW, ML, MR, NE, SN, TD, TG).
- Published:
— with international search report
- For two-letter codes and other abbreviations, refer to the "Guidance Notes on Codes and Abbreviations" appearing at the beginning of each regular issue of the PCT Gazette.

(54) Title: METHOD AND DEVICE FOR MEASUREMENTS IN BLOOD

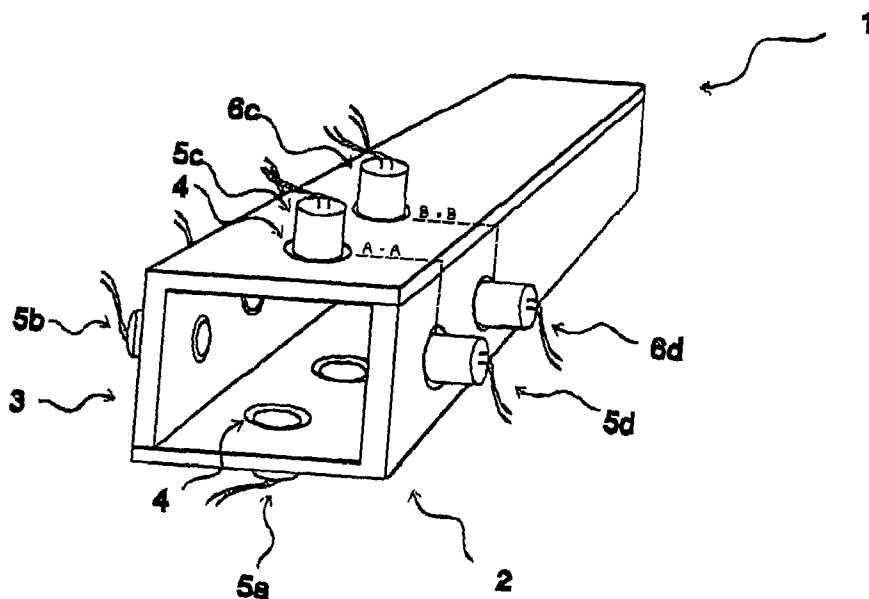

(57) Abstract: We present an optical probe arrangement that surrounds blood in a receptacle. It comprises LED's and light detector arranged to overcome the variations when the receptacle is translucent medical tubing and the like. Also, a signal processing algorithm is used to average signals from a plurality of light detectors, to further enhance results when measuring hematocrit. The invention makes it possible to add the feature of hematocrit measurement into dialysis system without major alterations to the dialysis machine or transport tubing.

WO 2004/057313 A1

Method and device for measurements in blood

Background of the invention

Hematocrit is the concentration of red blood cells (RBC) in blood. The measurement
5 of hematocrit values is of great importance in the assessment of the condition of a patient.
The established method of measuring hematocrit is by drawing blood from the subject
(patient). Various methods to optically measure hematocrit by optical or ultrasonic means
have been attempted, e.g., during a dialysis treatment of a patient. In these situations, not
10 only the level of hematocrit is of high importance but also the relative variation of this
parameter. In order to provide an optimized but still safe dialysis treatment the change of
the hematocrit or relative blood volume has to be monitored during the treatment. The
attempts to monitor this have so far not resulted in any product that can measure the
hematocrit without a special cuvette integrated in the transport tubing. The methods used
15 so far have therefore increased the cost of every dialysis treatments since the transport
tubing must be equipped with this single-use cuvette. The invention presented here does
not require any special cuvette, instead it provides the possibility to measure the
hematocrit, or monitor the change of relative blood volume directly on any standard
dialysis transport tubing on the market without increasing the cost of each treatment.

20 Technical field

The invention relates to measuring various blood constituents with optical means.
Blood is irradiated with – preferably – near infrared or infrared light. Light scattering and
attenuation of the light is measured and novel compensations for optical variations in the
receptacle walls, flow etc. is used to calculate blood constituents such as hematocrit. The
25 invention makes it possible to add the feature of hematocrit measurement without major
alterations into any dialysis system. The addition of this feature makes blood volume
measurements at hand.

Prior art

30 Hematocrit has been measured with various methods since the early hood of medical
diagnosis. Continuous measurement is particularly useful during dialysis treatment. During
the process of dialysis, liquids are extracted from the blood stream. As a result, hematocrit

increases during the process. For the assurance of good quality in the dialysis treatment, the hematocrit value should be monitored, as this provides the care provider with essential information regarding the rate of extraction of fluids from the patient's bloodstream.

5 Various techniques have been presented in the field of optical measurements of hematocrit in blood. Several make use of the scattering effect RBC has on light passing through blood in a vessel, cuvette or the like. Oppenheimer presents in patent US 5,601,080 a method to measure the degree of scatter to derive blood constituents.

10 Other patents are US 4,745,279 to Karkar, describing scattering effect of blood in a cuvette. US 6,493,567 to Krivitski et al. describes a measuring instrument using one light emitting diode and one sensor. US 6,064,474 to Wylie et al is another description of a hematocrit measuring method using the scattering effect RBC has on light. However the known methods and devices do not provide a satisfactory precision.

The invention

15 The above objects are in accordance with the invention achieved by emitting light into the blood and then two detectors placed opposite each other are used to execute the measuring.

20 In accordance with the present invention, a new method and a novel apparatus are presented to measure blood properties with a procedure comprising a new optical probe arrangement that overcomes the problem of the prior art, as for instance optical variations, such as optical density, refractions etc. The invention may even take the shape of a clamp that with great ease can be applied on a transparent tubing such as transport tubing in dialysis. The new probe makes hematocrit values available with unsurpassed precision in the art, in spite of the fact that it measures through transparent tubing that vary in thickness
25 and shape.

30 In the practical embodiment of the invention the blood is measured as it flows through a transparent tubing. A beam of light, for instance from a laser is directed perpendicular into the tube and two sensors opposed to each other and perpendicular to the light beam pick up light and the sensor signals are used for the evaluation. The light source and the sensors may lie in the same plane but the plane of the sensors may also be slightly offset in relation to the light beam, for instance along the tubing. One can also consider using several pairs of sensors offset along the tubing and upstream as well as downstream

in order to increase precision. Also a third sensor may be added to each pair, this third sensor being placed close to the light source.

In this solution the sensor offset in relation to the light source may advantageously be so large that the sensing sectors of the two sensors do not intersect the light beam. With increasing offset the sensitivity to relative changes is increased, whereas a smaller offset will provide a more accurate absolute measurement of the hematocrit value. It is thus possible to use one set of sensors to establish an absolute value and then use a set of more offset placed sensors for the monitoring and controlling of the level during dialysis.

Further preferable developments are apparent from the claims and the following description of a preferred embodiment of the invention.

Brief description of the drawings

Fig. 1 is a cross section of an optical probe arrangement 1, accommodating light emitting diodes 5 in holes 4 in a framework comprising two halves 2 and 3 suited to fit a receptacle 8 such as tubing for blood 9.

Fig. 2 is a cross section of an optical probe arrangement 1, accommodating light detectors 6 in holes 4 in a framework comprising two halves 2 and 3 suited to fit a receptacle 8 such as tubing for blood 9.

Fig. 3 depicts the arrangement of the array of light detectors 5 and light emitting diodes 6 on the optical probe arrangement 1. This is a suggestion where the arrays according to Fig. 1 and Fig. 2 are located with indication "A - A" for the light emitting diodes, and "B - B" for the light detectors.

Fig. 4 depicts the arrangement of a second array of light detectors 7.

Fig. 5 depicts the optical probe arrangement 1 with the further embodiment of light emitting diodes 9, and photo detectors 8.

Fig. 6 depicts the resulting hematocrit values with reference to measurements performed at an accredited clinical laboratory.

Description

We have achieved very good results by using the following arrangement of light - emitting diodes (LED's) and photo detectors, when assessing hematocrit values. These values correlate very well with laboratory reference values.

Four LED's are arranged in a preferably – but not limited to – perpendicular fashion to each other around a receptacle, such as tubing, for the blood as apparent in Fig. 1. The light detectors are arranged in a fashion where they similarly are preferably perpendicular to each other according to Fig 2, but at a distance longitudinally away from the encirclement by the LED's, as exhibited in Fig. 3. In a further embodiment, a second encirclement of light detectors is fitted. The arrangement is apparent in Fig. 4.

The LED and photo detector arrangement should for best understanding be viewed as groups of LED's and photo detectors: For instance, LED 5 a, and photo detector 6 b is one group. Another group can be LED 5 b, and photo detector 6 a and 6 c. Note that no LED's and photo detectors are aligned to achieve direct transmitted light. The invention does not make use of directly transmitted light, as often is the case in prior art.

A sample of light detected from a group of one or several photo detectors can be taken at any one short instance in time. Another sample can be taken from the same or another group as a second sample. Preferably, a first sample is taken from a first group comprising LED 5 a, and light detectors 6 b and 6 d, a second sample is taken from a second group comprising LED 5 b, and light detectors 6 a and 6 c, a third sample is taken from a third group comprising LED 5 c, and light detectors 6 b and 6 d, and finally a fourth sample is taken from a fourth group comprising LED 5 d, and light detectors 6 a and 6 c. A first result is derived from these four sequentially acquired samples being signal processed. The process can include variations of amplification factors for the signals from the detectors, and also correlation factors between these signals, to further enhance the detection of the blood constituent to be measured. The results make a first result for blood constituents, such as hematocrit. In this process, the error occurring from variations in the cross section of the flow pattern in the vessel is reduced. Furthermore averaging may reduce the effect the vessel wall has on the measurement. This is highly beneficial if the vessel is the extracorporeal circuit of a dialysis system. One of the major advancements in the disclosed invention resides in the new possibility to measure hematocrit through the walls of dialysis extracorporeal circuit, namely the so-called transport tubing of the circuit. It is highly advantageous that no special cuvettes or dedicated arrangements to the disposable bloodlines are necessary. Our process even makes it unnecessary to fit dedicated tubing to the extracorporeal circuit. This feature is considerably cost saving for the health care provider. Fitting the hereby disclosed probe on the transport tubing also has the advantage

that the probe is not interfering with the ordinary functions of the dialysis system. Also, it furnishes the highly beneficial possibility to upgrade any already existing dialysis system with measurement of hematocrit, even if it is not prepared for such purpose. Subsequently blood volume changes can be calculated and displayed.

5 In one embodiment of the invention, two arrays of detectors are employed. Downstream (or upstream) a blood flow in a vessel such as tubing, a second array of detectors is fitted. This is apparent in Fig 4. The mathematical signal processing can further enhance the results by including this "second order" of detectors in the process.

10 In another embodiment of the invention, a second arrangement of LED's and photo detectors, including a second array of detectors is fitted. This is exhibited in Fig 5. In this embodiment, the LED's emits a different wavelength. This allows limited spectral analysis for further calculation of blood constituents, such as saturation of hemoglobin as known in the art. The results derived from this second array, can beneficially be incorporated in a signaling process with the values derived from the aforementioned first array. Such
15 process makes it possible not only to output all parameters from blood constituents, but also let the saturation value influence the input of signals from the first array to the signaling process. This is beneficial, as blood saturation may influence the first results of blood constituents from the first process from the first array.

20 In the drawings and the above description a transparent blood transporting tubing is shown clamped between two essentially V-shaped profiles in the walls of which the led and sensors are arranged. In an alternative embodiment V-shaped groves in blocks may be used to clamp and shape the tubing so that its walls become essentially flat at LEDs and sensors.

In a further embodiment the sensors may be arranged in small holes with even smaller openings serving as collimators towards the tubing.

25 It is not today clear why the invented measuring method and device are so superior in relation to the prior art, one theory could be the offset between sensors and light source. Only light that has been dispersed from the volume of the blood in the path of the light and into the sense sector of the sensor and from this into the sensor will be registered. In other word only light that has been dispersed at least twice will reach the sensor. By arranging
30 source and sensor perpendicularly blood cells in a major part of the tube cross section will have the opportunity to contribute so that the signals from the sensors become a function of the hematocrite value.

Claims

1. Method for the measuring of the density of blood cells in blood **characterized in** the directing of a light beam into the space that is to be investigated and that one or several
5 sensors are so arranged that its or their sense sectors do not intersect the beam of the light source in the volume.
2. Method according to claim 1, **characterized in** that two sensors are used that are opposed to each other.
3. Method according to claim 1 or 2, **characterized in** that light beam and sensor
10 sector(s) are perpendicular to each other.
4. Sensor device for the measuring of the density of blood cells in blood **characterized in** comprising vessel or tubing, a light beam emitter facing the tubing, and one or several sensor(s) also facing the vessel and so arranged that its or their sense sectors do not intersect the beam of the light source in the vessel or tubing.
- 15 5. Sensor device according to claim 4, **characterized in** that the locations of the light source and sensor(s) respectively are separated lengthwise of the vessel or tubing.
6. Sensor device according to claim 4 or 5, **characterized in** that two sensors are arranged with their sensing directions perpendicular to the light beam.
- 20 7. An optical probe arrangement that surrounds blood in a receptacle, said optical probe arrangement comprising at least two sets of light emitters and light detectors, each set comprising one light emitter and at least one detector, each set arranged to transilluminate the blood at a preferred angle between said light emitter and said light detector – or detectors – of each set, where said angle is at least sufficient to avert direct light from said light emitter to said light detector, for the detection of blood constituents.
- 25 8. An optical probe arrangement according to claim 7, comprising four sets of light emitters and two or three light detectors in each set, wherein a light detector may represent a detector incorporated in an adjacent set.
9. An optical probe arrangement according to claim 7 or 8, wherein the light emitters are arranged as an array to encircle an elongated receptacle at longitudinally one location
30 around said receptacle's circumference, and the light detector are arranged to encircle the receptacle at a different circumferential location.
10. An optical probe arrangement according to any of the claims 7-9, wherein a

second array of light detectors are longitudinally located at a third location around said receptacle's circumference, and the light detector are arranged to encircle the receptacle at that circumferential location.

5 11. A method to process signals from light detectors in accordance with any of the claims 4-10, comprising means to amplify signals from the light detectors and the employment of a signal processing algorithm on the signals from said light detectors, to detect blood constituents.

10 12. A method to process signals from light detectors in claim 8, comprising means to amplify signals from the light detectors and employ a signal processing algorithm on the signals from said light detectors, to detect hematocrit.

13. A method according to claim 12, the signal processing means comprising a multi variable analysis of signals from all light detectors engaged in the signaling process.

15 14. An optical detector or probe arrangement according to any of the claims 4-10, where a third array of light detectors are longitudinally located at a fourth location around said receptacle's circumference, and the light detector are arranged to encircle the receptacle at that circumferential location and an second array of light emitting diodes longitudinally located at a fifth location around said receptacle's circumference, and the light detectors are arranged to encircle the receptacle at that circumferential location.

20 15. A method to process signals from light detectors in accordance with claim 14, comprising means to amplify signals from the light detectors and employing a signal processing algorithm on the signals from said light detectors, to detect blood constituents.

16. A method to process signals from light detectors in claim 15, comprising means to amplify signals from the light detectors and employ a signal processing algorithm on the signals from said light detectors, to detect hematocrit.

25 17. Method to process signals from light detectors in any of the claim 4-10, comprising means to amplify signals from the light detectors and employ a signal processing algorithm on the signals from said light detectors, to detect oxygen saturation in blood.

30 18. Method according to any of the preceding method claims comprising a signal process, where signals are processed in the time domain.

19. An apparatus according to any of the claims 4-10 claims, comprising a system to calculate hematocrit values from blood, and presenting the data to a display, and/or

transferring data to another application.

20. An apparatus according to any of the claims 4-10, comprising a system to calculate hematocrit values and oxygen saturation values from blood, and presenting the data to a display, and/or transferring data to another application.

5 21. Method for the measuring of the density of blood cells in blood, **characterized in** the directing of a light beam into the space that is to be investigated and that two sensors, are used that are opposed to each other.

22. Method according to claim 21, **characterized in** that light beam and sensor "beams(s)" are perpendicular to each other.

10 23. Probe or detector arrangement according to any of the claims 4-10 or 19-20, **characterized in** that the measuring takes place in a tubing that is clamped in a holder with V-shaped recesses so that tube is given a square cross section and that light sources and sensors are arranged at the flat surfaces.

Fig. 1

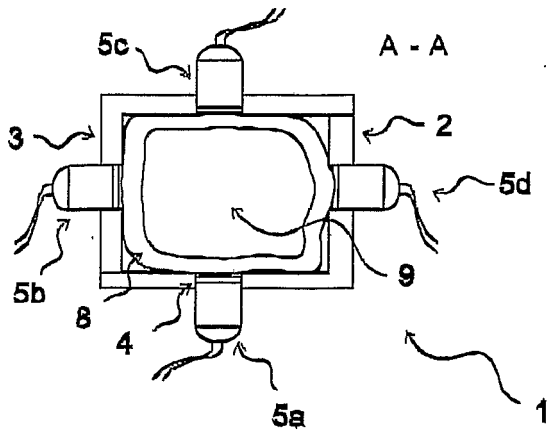

Fig. 2

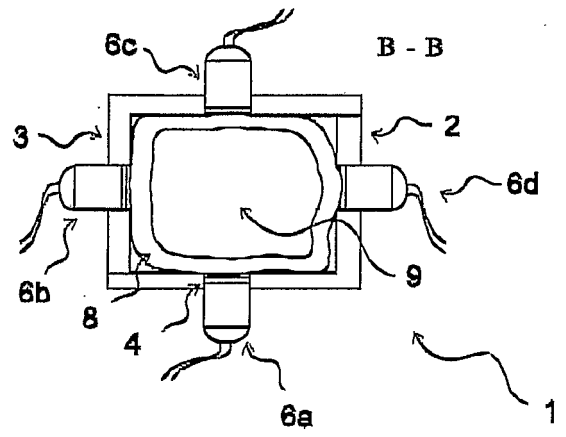

Fig. 3

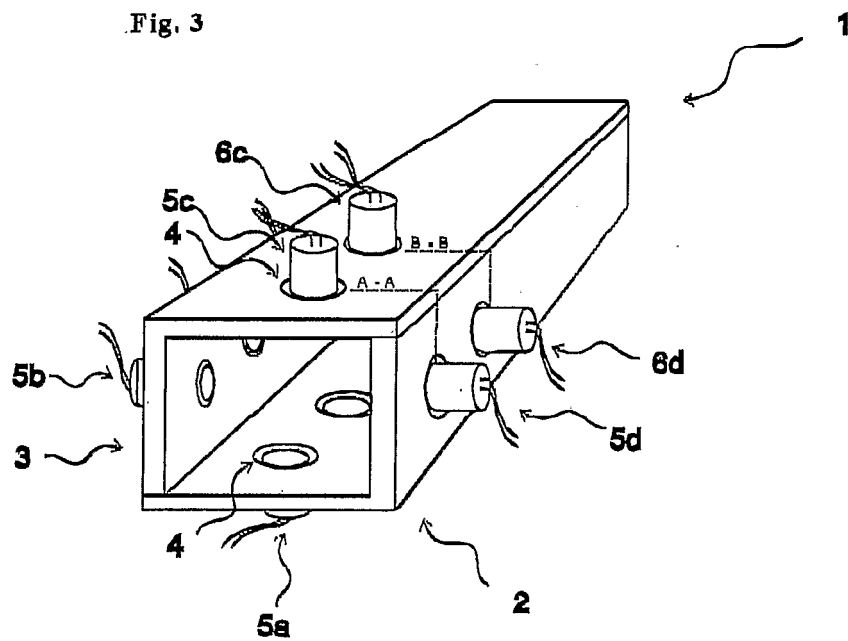

Fig. 4

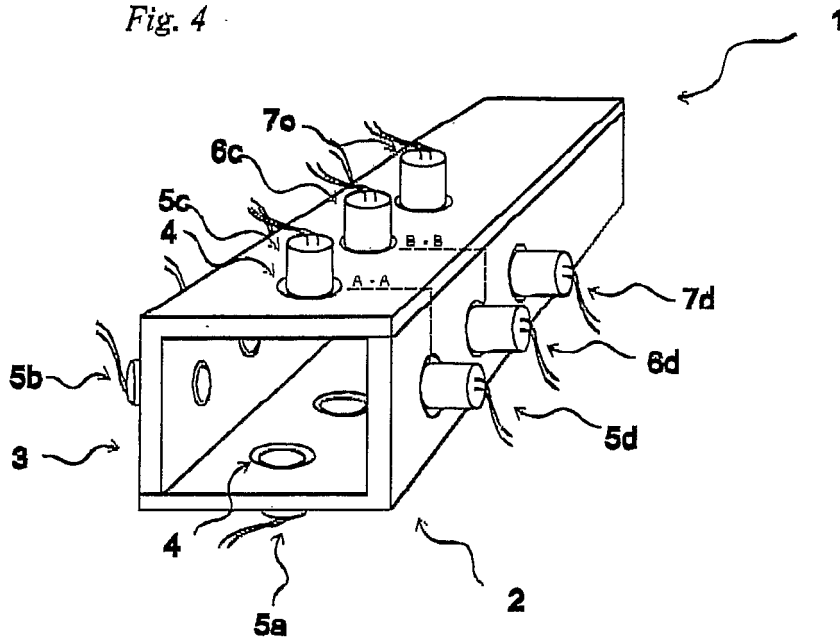
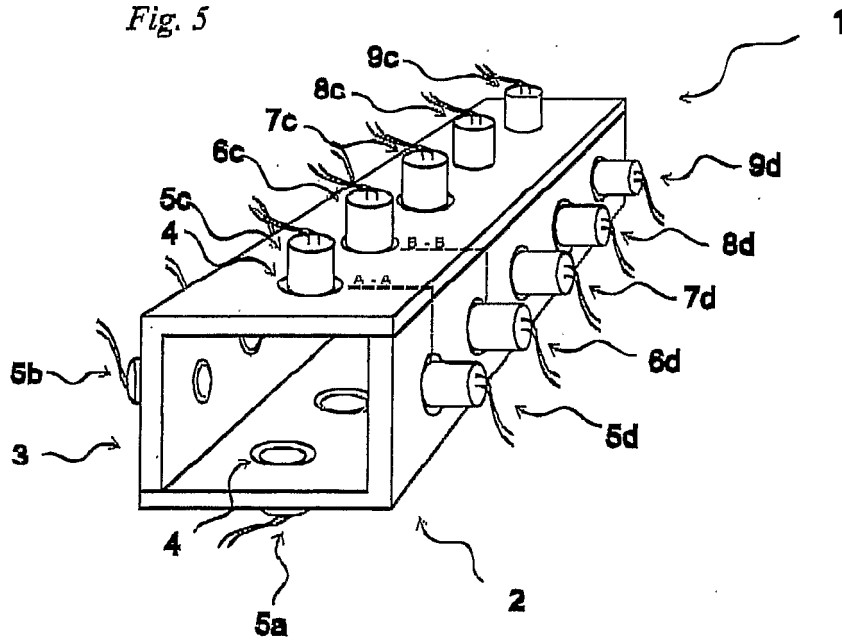

Fig. 5



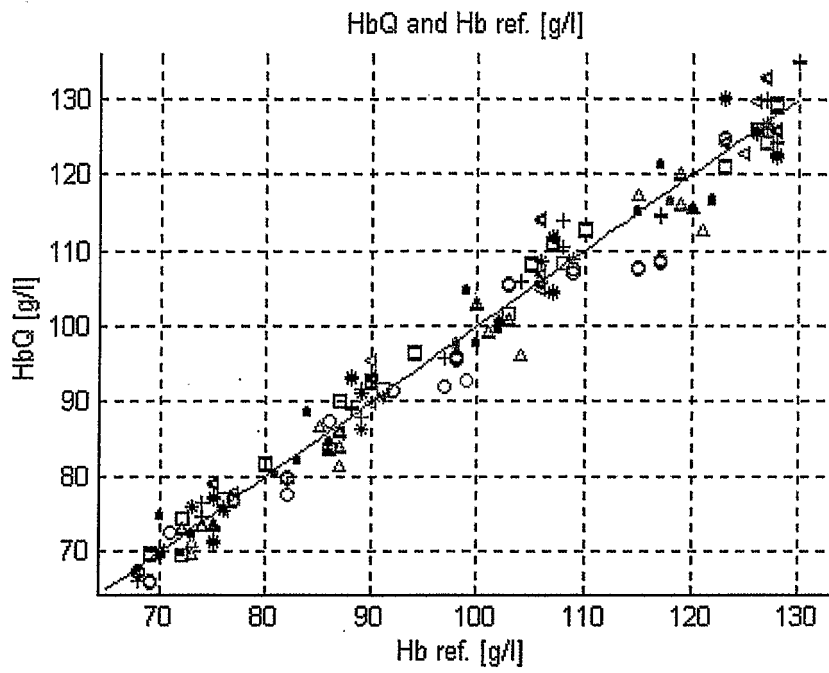

Fig. 6

INTERNATIONAL SEARCH REPORT

International application No.

PCT/SE 2003/002013

A. CLASSIFICATION OF SUBJECT MATTER

IPC7: G01N 21/05, G01N 21/53

According to International Patent Classification (IPC) or to both national classification and IPC

B. FIELDS SEARCHED

Minimum documentation searched (classification system followed by classification symbols)

IPC7: G01N

Documentation searched other than minimum documentation to the extent that such documents are included in the fields searched

SE,DK,FI,NO classes as above

Electronic data base consulted during the international search (name of data base and, where practicable, search terms used)

EPO-INTERNAL, WPI DATA

C. DOCUMENTS CONSIDERED TO BE RELEVANT

Category*	Citation of document, with indication, where appropriate, of the relevant passages	Relevant to claim No.
X	WO 0033053 A1 (ENEJDER, A), 8 June 2000 (08.06.2000), page 5, line 15 - line 23	1,3-4,11, 17-22
Y	--	23
Y	EP 0575712 A2 (UNIVERSITY OF MANITOBA), 30 March 1993 (30.03.1993), column 12, line 23 - line 27, abstract	23
A	US 4745279 A (KARKAR, M N ET AL), 17 May 1988 (17.05.1988), column 3, line 28 - line 38	1-23
	--	

 Further documents are listed in the continuation of Box C. See patent family annex.

* Special categories of cited documents:

"A" document defining the general state of the art which is not considered to be of particular relevance

"E" earlier application or patent but published on or after the international filing date

"L" document which may throw doubts on priority claim(s) or which is cited to establish the publication date of another citation or other special reason (as specified)

"O" document referring to an oral disclosure, use, exhibition or other means

"P" document published prior to the international filing date but later than the priority date claimed

"T" later document published after the international filing date or priority date and not in conflict with the application but cited to understand the principle or theory underlying the invention

"X" document of particular relevance: the claimed invention cannot be considered novel or cannot be considered to involve an inventive step when the document is taken alone

"Y" document of particular relevance: the claimed invention cannot be considered to involve an inventive step when the document is combined with one or more other such documents, such combination being obvious to a person skilled in the art

"&" document member of the same patent family

Date of the actual completion of the international search

8 March 2004

Date of mailing of the international search report

10-03-2004

Name and mailing address of the ISA/

Swedish Patent Office
Box 5055, S-102 42 STOCKHOLM
Facsimile No. +46 8 666 02 86

Authorized officer

Mats Raidla /LR
Telephone No. +46 8 782 25 00

INTERNATIONAL SEARCH REPORT

International application No.

PCT/SE 2003/002013

C (Continuation). DOCUMENTS CONSIDERED TO BE RELEVANT		
Category*	Citation of document, with indication, where appropriate, of the relevant passages	Relevant to claim No.
A	US 6493567 B1 (KRIVITSKY, N M ET AL), 10 December 2002 (10.12.2002), abstract --	1-23
A	US 6388752 B1 (ZIEGLER, W ET AL), 14 May 2002 (14.05.2002) -- -----	1-23

INTERNATIONAL SEARCH REPORT
Information on patent family members

27/02/2004

International application No.

PCT/SE 2003/002013

WO	0033053	A1	08/06/2000	AU	1701800	A	19/06/2000
				EP	1147399	A	24/10/2001
				JP	2002531824	T	24/09/2002
				SE	9804142	D	00/00/0000
				US	6510330	B	21/01/2003

EP	0575712	A2	30/03/1993	SE	0575712	T3	
				DE	69332325	D,T	05/06/2003
				ES	2179045	T	16/01/2003
				GB	9206954	D	00/00/0000
				JP	3378890	B	17/02/2003
				JP	6038947	A	15/02/1994
				US	5331958	A	26/07/1994
				GB	9206967	D	00/00/0000
				GB	9206970	D	00/00/0000

US	4745279	A	17/05/1988	CA	1279499	A,C	29/01/1991
				EP	0231652	A	12/08/1987
				JP	62265563	A	18/11/1987

US	6493567	B1	10/12/2002	US	2003130570	A	10/07/2003
				US	6041246	A	21/03/2000

US	6388752	B1	14/05/2002	AT	90099	A	15/02/2000
				AT	232976	T	15/03/2003
				AT	406912	B	25/10/2000
				DE	50001263	D	00/00/0000
				EP	1054252	A,B	22/11/2000
				ES	2188497	T	01/07/2003
				JP	3318657	B	26/08/2002
				JP	2000356582	A	26/12/2000

专利名称(译)	血液中测量的方法和装置		
公开(公告)号	EP1579196A1	公开(公告)日	2005-09-28
申请号	EP2003768470	申请日	2003-12-18
[标]申请(专利权)人(译)	OPTOQ		
申请(专利权)人(译)	OPTOQ AB		
当前申请(专利权)人(译)	OPTOQ AB		
[标]发明人	PETTERSON MAGNUS DAHLSTROM ANNA PETTERSON HANS		
发明人	PETTERSON, MAGNUS DAHLSTRÖM, ANNA PETTERSON, HANS		
IPC分类号	A61B5/00 G01N15/00 G01N15/02 G01N21/05 G01N21/53		
CPC分类号	A61B5/14535 A61B5/14557 G01N15/0211 G01N21/05 G01N21/53 G01N2015/0065		
优先权	0203868 2002-12-20 SE 0203869 2002-12-20 SE		
其他公开文献	EP1579196B1		
外部链接	Espacenet		

摘要(译)

我们提出了一种围绕容器中的血液的光学探针装置。它包括LED和光检测器，其布置成克服当容器是半透明医用管等时的变化。而且，信号处理算法用于平均来自多个光检测器的信号，以在测量血细胞比容时进一步增强结果。本发明使得可以将血细胞比容测量的特征添加到透析系统中而无需对透析机或输送管进行重大改变。