

(19) World Intellectual Property  
Organization  
International Bureau



(43) International Publication Date  
13 May 2004 (13.05.2004)

PCT

(10) International Publication Number  
**WO 2004/040253 A2**

- (51) International Patent Classification<sup>7</sup>: **G01N**
- (21) International Application Number: PCT/IL2003/000907
- (22) International Filing Date: 2 November 2003 (02.11.2003)
- (25) Filing Language: English
- (26) Publication Language: English
- (30) Priority Data: 10/285,499 1 November 2002 (01.11.2002) US
- (71) Applicant (for all designated States except US): **COMMON SENSE LTD.** [IL/IL]; 7 Haeshel Street, Zone 2, Caesare Industrial Park 38900 (IL).
- (72) Inventors; and
- (75) Inventors/Applicants (for US only): **KRITZMAN, Amnon** [IL/IL]; Zahal Street 9, 30900 Zichron Yaakov (IL). **NACHSHON, Nitsa, G.** [IL/IL]; Kibbutz Geva 18915 (IL). **BECHAR, Yael** [IL/IL]; Moshav Ein Ayala 30825 (IL).
- (74) Agent: **WEBB, Cynthia**; Webb & Associates, P.O. Box 2189, Rehovot 76121 (IL).
- (81) Designated States (national): AE, AG, AL, AM, AT, AU, AZ, BA, BB, BG, BR, BW, BY, BZ, CA, CH, CN, CO, CR, CU, CZ, DE, DK, DM, DZ, EC, EE, EG, ES, FI, GB, GD, GE, GH, GM, HR, HU, ID, IL, IN, IS, JP, KE, KG, KP, KR, KZ, LC, LK, LR, LS, LT, LU, LV, MA, MD, MG, MK, MN, MW, MX, MZ, NI, NO, NZ, OM, PG, PH, PL, PT, RO, RU, SC, SD, SE, SG, SK, SL, SY, TJ, TM, TN, TR, TT, TZ, UA, UG, US, UZ, VC, VN, YU, ZA, ZM, ZW.
- (84) Designated States (regional): ARIPO patent (GH, GM, KE, LS, MW, MZ, SD, SL, SZ, TZ, UG, ZM, ZW), Eurasian patent (AM, AZ, BY, KG, KZ, MD, RU, TJ, TM), European patent (AT, BE, BG, CH, CY, CZ, DE, DK, EE, ES, FI, FR, GB, GR, HU, IE, IT, LU, MC, NL, PT, RO, SE, SI, SK, TR), OAPI patent (BF, BJ, CF, CG, CI, CM, GA, GN, GQ, GW, ML, MR, NE, SN, TD, TG).
- Published:**  
— without international search report and to be republished upon receipt of that report
- For two-letter codes and other abbreviations, refer to the "Guidance Notes on Codes and Abbreviations" appearing at the beginning of each regular issue of the PCT Gazette.



**WO 2004/040253 A2**

(54) Title: SECRETION-TESTING ARTICLE

(57) Abstract: The present invention teaches pH indicator polymer matrices and methods of using same for identifying vaginal secretions. A secretion-monitoring article for the identification of secreted biological fluids is disclosed having a substrate for absorbing a biological fluid secreted from a person, and biocompatible pH indicator polymer matrices comprising at least one pH determining reagent that reacts with biological fluids that have low buffer capacity differently than with bodily fluids that have normal buffer capacity.

## SECRETION-TESTING ARTICLE

### FIELD OF THE INVENTION

The present invention relates to a secretion-testing article containing a pH indicator polymer matrix that provides improved diagnosis of secretions such as amniotic fluid or vaginal secretions associated with bacterial, parasite, fungal, or yeast infections. The present invention further relates to methods of preparing and using the secretion-testing article.

### BACKGROUND OF THE INVENTION

Many medical conditions can be diagnosed by identifying the chemical and physical properties of a vaginal secretion, such as, by identifying the pH of the secretion. A number of devices involving panty shields with pH indicators are known in the art, for example in U.S. Pat. Nos. 5,217,444, 5,823,953 and 6,106,461. These devices can be worn by the user and whenever there is a secretion it is immediately detected by the pH indicator. International patent application WO01/13097 discloses an indicator bound to a hydrophilic synthetic membrane substrate and a device, such as a panty shield with an indicator bound to hydrophilic synthetic membrane substrate.

A general problem, however, with these pH indicators is that they often provide "false positives" due to changes in pH on drying, interfering biological fluids and repetitive cycles of drying/wetting. Often a vaginal secretion cannot be identified with absolute certainty by an indicator due to the existence of a plurality of fluids collected with a similar pH such as due to the existence of urine. The "false positive" readings can be stressful and time consuming to the user. A device that minimizes these "false positive" readings is needed.

25

Bacterial Vaginosis (BV) is a mild infection in the vagina caused by anaerobic bacteria. BV is characterized by production of increases quantities of malodorous vaginal discharge. The vaginal discharge of women with BV described as being thin (low viscosity), off-white-grey (milk-like consistency), and homogeneous (distinctly not curd-like). Increase of water content due to transudation of extracellular fluid

30

cause dilution of the medium deriving to a low buffer capacity solution. One of the diagnostic criteria for BV is the pH of the vaginal secretion. Vaginal secretions of a patient with BV have a pH between 4.7 and 6.5. Because urine of a healthy patient has a pH between 5.0 and 8.0, it is very difficult to diagnose a secretion as arising from  
5 BV with a high degree of confidence by just using a pH based indicator test. One solution known in the art is to sample fluid from within the vagina, where urine is not ordinarily found. This is uncomfortable and requires a visit to a health-care professional.

10 Another clinical situation amenable to diagnosis on the basis of pH of vaginal secretions is the identification of amniotic fluid leakage during pregnancy. During pregnancy amniotic sac integrity may be compromised and a small amount of amniotic fluid may leak out through the cervix and from the vagina. If diagnosed as such, measures such as patient rest or sealing of the amniotic sac using biological glue  
15 may be prescribed. If not diagnosed the amniotic sac may later rupture causing abortion of the pregnancy, or require hospitalization of the woman and infant. If the infant is born prematurely, death or severe handicap may be a result. Extended hospitalization of the infant in an incubator is often necessary

20 Due to the severe consequences of amniotic fluid leakage, pregnant women often seek a health-care professional upon secretion of any liquid from the vicinity of the vagina. The health-care professional looks for the presence of amniotic fluid by checking the pH of the vaginal secretions, amniotic fluid having pH levels between 6.0 and 8.0. Routinely such a vaginal secretion is examined using a microscope for the  
25 presence of a fern-shaped pattern indicative of amniotic fluid.

As known in the art, usually pH indicators are attached to a solid substrate such as paper. A sample of a liquid of which the pH needs to be determined is applied to the substrate. The pH of the liquid is determined by comparing the color of the  
30 indicator present on the substrate to a color standard or standards. Depending on how the indicator is attached to the substrate, application of the liquid sample may cause the indicator to leach out of the substrate. Indicator leaching is undesirable and so the

indicator is often substantially immobilized onto the substrate. The leached indicator or use of an indicator that is not biocompatible can be harmful to the patient tissues and the health of the patient.

5 U.S. Pat. No. 6,126,597 (the '597 patent) and U.S. Pat. No. 6,149,590, (the '590 patent) a continuation-in-part of the '597 patent, are directed to a device in the form of a sanitary napkin with a pH indicator configured to identify the presence of amniotic fluid in a vaginal secretion is disclosed. The '597 and '590 patents are subject to the problem of giving false positive results. The device of the '590 patent address  
10 this problem by further including in the device a microscope visualizable slide configured to gather a portion of a vaginal secretion. If the indicator shows the pH corresponding to that of amniotic fluid, the user presents a health-care professional with the slide. The health-care professional examines the slide with the help of a microscope for the typical fern-shaped patterns indicative of the presence of amniotic  
15 fluid.

There are a couple of disadvantages associated with this device. First, it requires that the patient visit the health-care professional to distinguish between positive and false-positives and second, a significant amount of time is lost in the  
20 having the slide viewed by a professional to determine if amniotic fluid is actually leaking.

U.S. Pat. No. 5,897,834 discloses a device useful in a clinical setting for the differentiation between urine and vaginal secretions associated with vaginosis or urine  
25 and amniotic fluid. The device includes the use of indicators with a negatively charged group immobilized to a solid polymer substrate containing quaternary ammonium groups. Further the device includes a gaseous amine-releasing reagent and an amine indicator. The use of the polymer substrate containing quaternary ammonium groups is disclosed to have an advantage of sharpening the pH dependent  
30 color transition. However, these polymer substrates have been found to be less useful in non-clinical settings: the indicated pH of dried vaginal secretions is low enough to be misdiagnosed as indicating vaginosis. Thus although the device disclosed in U.S.

Pat. No. 5,897,834 is useful in a clinical setting where the health care professional applies the vaginal secretion to the device and observes the color change, if integrated in a patient useable device, such as a panty shield, the device gives abundant false positive results.

5

In US patent 6,627,394, the inventors of the present invention disclosed a diagnostic device for detection of vaginosis or amniotic fluid leakage without giving a false positive result due to contact with urine, the device comprising at least one pH indicator attached to a substrate and a reagent comprising urease attached to the substrate.

10

A number of devices involving swabs with pH indicators are known in the art, as disclosed for example in US Patents 6,013,036, 5,738,634, 5,664,579, 5,577,512 and 5,425,377. The advantage of using a swab substrate for pH indicators is the ability to monitor the pH of vaginal discharge directly from the vagina. As noted above, urine of a healthy patient has a pH between 5.0 and 8.0. Secretions from patients having bacterial vaginosis or parasite infection also have a pH between 4.7 and 6.5. Monitoring the pH of vaginal discharge directly from the vagina using a swab prevents false positive results due to the contact of the pH indicator with urine. A general problem, however, with these known swab-based pH indicators is that the reaction of the pH indicator is not dependent on the buffer capacity of the secretion.

15

20

Another problem of swabs containing pH indicators is that the indicators either tend to leach out from the substrate or they are not biocompatible. For example an indicator dye like Nitrazine attached to the swab tends to leach out from the substrate. Other examples of indicator materials known in the art are composed of non-biocompatible materials. Biocompatibility is determined by means of grade zero cytotoxicity, grade zero skin irritation and grade zero sensitization according to the USP criteria.

25

30

Still further problem with the pH indicators as are known in the art are that the color observation requires a color scale and that the sensitivity and the specificity



indicator according to the present invention is capable of differentiating between vaginal secretions and urine.

Any user, male or female, young or old, can use the article. The particular  
5 examples of the invention as presented herein are not intended to limit the scope of  
the invention, but simply to illustrate and represent the numerous potential forms in  
which the invention can be used.

In one aspect, the present invention provides improved impregnated swabs or  
10 strips comprising a biocompatible pH indicator polymer matrix that has at least one  
pH-determining reagent capable of diagnosing vaginal secretions such as secretions  
associated with bacterial vaginosis with very high accuracy. The swab or strip  
containing a pH-determining reagent is adapted for direct contact with the vagina and  
is capable of reacting with secretions having low buffer capacity differently than with  
15 bodily fluids having normal buffer capacity. The reagents used in the present  
invention have grade zero cytotoxicity and grade zero sensitization according to the  
USP criteria. Thus, the pH indicator polymer matrix of the present invention may be  
used without need of any cover or hydrophilic coating to separate between the article  
and the vaginal tissue.

20

In another aspect, a polymeric pH indicator of the present invention is attached  
to an article that is retained in the vicinity of a vaginal area of the person for an  
extended period to absorb the fluids while being worn. After which the article is  
removed and observed to determine the health condition of the person from which the  
25 biological fluid was collected. The polymer pH indicator according to the present  
invention is capable of differentiating between vaginal secretions and urine since it  
reacts with fluids that contain protonated amine cations (such as urine) differently  
than with fluids that do not contain protonated amine cations. Preferred articles are  
for example a panty shield, a hygienic napkin or a diaper.

30

The inventors of the present invention discovered unexpectedly that the  
present indicator system reacts with secretions that have low buffer capacity (such as

BV discharge) differently than with bodily fluids that have normal buffer capacity. Specifically, when the vaginal secretion possesses normal buffer capacity (preferably vaginal secretion having ionic concentration above 10mM) such as in normal vaginal discharge, the color of the Nitrazine yellow polymer matrix changes from yellow to green/blue when the pH of the vaginal discharge is above 5. However, in cases where the buffer capacity is low (preferably vaginal secretion having ionic concentration below 10mM) such as in bacterial vaginosis, the color of the pH indicator changes from yellow to green/blue when the pH of the vaginal discharge is in the range of 4.3-5.0. The color transition in pH values which are lower than pH 5 enables to reduce the percentage of false-negative bacterial vaginosis cases which may be missed when conventional immobilized pH indicators is used. Thus, the new indicator system of the present invention enables the identification of over 95% of bacterial vaginosis cases using direct testing of vaginal secretion with immediate and stable color response.

15

In addition to the increased sensitivity of the indicator system of the present invention in detecting vaginal discharge having low buffer capacity, the pH indicator polymer matrix of the present invention exhibits additional advantage over the art. The pH polymer matrix of the present invention is capable of reacting differently with urine due to protonated amine cations that are present in substantial amounts only in urine, and not in the other biological fluids to be identified. Thus, although the pH of urine overlaps with the pH of amniotic fluid or BV discharge, the pH polymer matrix of the present invention is capable of differentiating between urine and amniotic fluid or BV discharge due to the presence of high amounts of protonated amine cations only in urine.

20  
25

In a preferred embodiment, the article of the present invention includes an absorbent material and an indicator system attached to a tip of a swab or strip for direct testing of the bodily fluids inside the female vagina. The use of a swab or strip reduces the risk that contact of the indicator with urine might interfere with the results. Furthermore, the indicator system is associated with an absorbent material such that the biological fluids contact the indicator system so that an immediate reliable

30

indication of the pH of that fluid can be obtained. The article of the present invention may be used for direct testing of the bodily fluids inside the female vagina without any concern of toxicity or leaching of the indicator.

5 In another embodiment, the article of the present invention includes an absorbent material and an indicator system attached to a panty shield, hygienic napkin, or a diaper. According to this embodiment, the pH indicator polymer matrix of the present invention is attached to an article that is retained in the vicinity of a vaginal area of the person for an extended period to absorb the fluids while being worn.

10

The pH indicator of the present invention does not require a color scale in order to interpret the results. The color produced by the indicator following the contact with the vaginal secretion remains stable up to one hour, and does not leach even when in contact with liquids.

15

According to various embodiments, the article can be used to indicate the presence of amniotic fluid, or secretions associated with bacterial, parasite, fungal, or yeast infections with immediate color response, wherein the color change is dependent on the buffer capacity of the tested vaginal secretion. Usually, the pH range  
20 of vaginal secretions in case of bacterial vaginosis or Trichomonas infections is over pH 5 and the buffer capacity is below 10mM. In case of Candida the pH level of the vaginal secretion is usually under 4.3 and the buffer capacity is above 10mM, and in case of mix infections of BV with Candida, the buffer capacity is under 10mM. The indicator system composition is capable of differentiating between normal or  
25 Candida-infected vaginal secretions which are characterized by normal buffer capacity, and bacterially infected vaginal secretions which are characterized by low buffer capacity. When the article of the present invention is contacted by bacterially or parasitic infected vaginal secretion having a buffer capacity lower than normal, the pH polymer matrix changes the color in a pH range between 4.3 to 5.0.

30

The present invention further relates to methods of preparing and using the secretion-monitoring article. The present invention provides a polymer matrix pH

indicator and methods of impregnating the indicator to a substrate. The present invention further provides methods for monitoring the health condition of a person, using the secretion-monitoring article comprising an indicator that reacts with biological fluids that have low buffer capacity differently than with bodily fluids that  
5 have normal buffer capacity.

The article of the present invention may be in the form of a swab, a strip, a gauze, a panty shield, a hygienic napkin, a diaper or any other absorbent structure to be used by any user at the clinic by professional or at home for self-testing. The  
10 particular examples of the invention as presented herein are not intended to limit the scope of the invention, but simply to illustrate and represent the numerous potential forms in which the invention can be used.

Preferably, the article has mounting means for positioning the absorbent body  
15 to come in contact with the fluids secreted by the vagina at the clinic by professional or at home for self testing, such mounting means being, for example, a swab tip or strip, adhesive strips associated with the article or any other attachment member.

These and further embodiments will be apparent from the detailed description  
20 and examples that follow.

### BRIEF DESCRIPTION OF THE DRAWINGS

**Figure 1** is a schematic view of the secretion-monitoring swab of the present invention.

**Figure 2** is a schematic perspective view of the secretion-monitoring swab of the  
25 present invention.

**Figure 3** is a graph showing the change in the color of the polymer versus the change in pH, wherein the color scale conversion is as follows: 0- Yellow; 1- Light Green; 2- Green; 3- Dark green.

**Figure 4** is a graph demonstrating the buffering capacity of vaginal secretions. The  
30 graph compares the pH of the butter or secretion being titrated by the NaOH 0.1 M

added.

**Figure 5** is a general schematic perspective view of a different embodiment designed to be integrated on ordinary panty shield.

**Figure 5A** is a schematic top view of a different embodiment of the secretion-monitoring article of the present invention with pH indicator polymer matrix device on top of the absorbent layer (3).

**Figure 5B** is a schematic top view of a different embodiment of the secretion-monitoring article of the present invention with option to pull out the pH indicator polymer matrix device by the tail that tears the pH indicator polymer matrix device from the absorbent layer.

**Figure 5C** is a schematic top view of the secretion-monitoring article of the present invention with option to pull out the pH indicator polymer matrix device by means of a tail, wherein the pH indicator is stained due to the contact with vaginal secretion of pH above 5 or with low buffer capacity, or urine before reverse reaction of the color back to yellow.

**Figure 5D** is a schematic top view of the pulled-out pH indicator polymer matrix after it has been withdrawn from the device along the perforated line.

**Figure 5E** is a schematic top view of a different embodiment of the open drying box that accelerate the reverse reaction time of the color change due to urine stain back to yellow

**Figure 5F** is a schematic top view of the pH indicator polymer matrix device with the tail inside the closed drying unit.

#### **DETAILED DESCRIPTION OF THE PREFERRED EMBODIMENTS**

The present invention provides secretion-monitoring article and a method for using thereof that allows both professional and untrained users to monitor secreted biological fluids such as secretions associated with bacterial vaginosis with high accuracy. The present invention further teaches a pH polymer matrix and method of attaching the mixture to a substrate. In a preferred embodiment, the article is in the form of impregnated swab or strip which can be applied directly to the vagina without any need to separate between the polymer matrix indicator and the vagina tissues by

any cover or hydrophilic coating.

Bacterial vaginosis (BV) is characterized by production of increased quantities of malodorous vaginal discharge. As mentioned above, one of the characteristics of  
5 BV is the homogeneous discharge. A women having BV typically has an increase in the discharge amount. The source of this liquid is extracellular fluid (interstitial fluid) that surrounds the epithelial cells in the vagina wall. A decrease in protein levels and other large organic molecules and the increase of water content in BV secretions lowers the buffer capacity of the secretions. Thus, secretions associated with BV have  
10 a lower buffer capacity than normal vaginal secretions.

The pH indicator polymer matrix of the present invention possesses significant advantages over the art. The inventors of the present invention discovered unexpectedly that the present indicator system reacts with secretions that have low  
15 buffer capacity (such as BV discharge) differently than with bodily fluids that have normal buffer capacity. Thus, in cases where the buffer capacity is low (preferably vaginal secretion having ionic concentration below 10mM) such as in bacterial vaginosis, the color of the pH indicator changes when the pH of the vaginal discharge is in the range of 4.3-5.0.

20

Furthermore, the pH indicator polymer matrix consists of a special composition that reacts with fluids containing protonated amine cations, such as urine, in a different way than it reacts to other biological fluids that have a low concentration of protonated amine cations, such as amniotic fluid. Specifically, during the drying  
25 process of the indicator system, the turquoise or green color obtained following the contact of urine with the indicator fades as it dries and the color of the indicator becomes yellow again. In contrast, when the indicator is contacted by amniotic fluid the indicator strip changes color from yellow to green or turquoise and does not fade when dried.

30

Furthermore, the polymer pH indicator of the present invention reacts with normal urine differently than infected or protein-containing urine. In one non-limiting

example, the indicator reacts with normal urine (pH 5-8), which changes the color from yellow to green or turquoise. During the drying process the color change of the indicator that has been contacted with normal urine fades as it dries and becomes yellow again. In contrast, when the indicator is contacted by infected or protein  
5 containing urine the indicator strip changes color from yellow to green or turquoise and does not fade when dried. Advantageously, this embodiment is well suited for all types of use, for example in pediatrics, geriatrics, and gynecology, and could be presented to the user in many forms.

10 The secretion-monitoring article can be implemented using many devices and methods. The body of the secretion-monitoring article of the present invention comprising the absorbent material can be supplied to the user for example in the form of a pad, gauze, a swab, a fiber ball, a sanitary napkin, diaper, panty shield, or interlabial structure. Details of manufacture of these are well known to one skilled and  
15 have been fully described in the prior art, for example U.S. Pat. Nos. 5,217,444, 5,897,834, and 6,149,590.

In a preferred embodiment, the article of the present invention is implemented as a swab or a strip in a manner that can be easily used by either skilled personnel or  
20 non-skilled user. The body of the secretion-monitoring article of the present invention comprising the absorbent material can be supplied to the user, for example, in the form of swab or a strip, a fiber ball, but most preferably, as a swab structure. Any user can use the article in a variety of forms. The particular examples of the invention as presented herein are not intended to limit the scope of the invention, but simply to  
25 illustrate and represent the numerous potential forms in which the invention can be used.

Furthermore, any user, male or female, young or old, can use the article in a variety of forms. The particular examples of the invention as presented herein are not  
30 intended to limit the scope of the invention, but simply to illustrate and represent the numerous potential forms in which the invention can be used.

The pH determining member of the indication system can be any pH determining device, for example as a color changing indicator (e.g., litmus paper) or a mobile pH probe. It is preferable, however, that the pH determining member be a color changing indicator, such as a pH determining member made from the pH indicator mixture described herein below and/or using the method of attaching the mixture to a substrate. More than one pH determining member can be part of the indicator system. The pH determining members should be capable of determining substantially different pH ranges or capable of reacting differently to different biological fluids to produce a different color change.

10

In a preferred embodiments of the secretion-monitoring article, a means for mounting the article to facilitate the collection of the secreted biological fluid is included. An example of a mounting means that is well known in the art is an adhesive strips associated with the article. In a preferred embodiment the article has one or more adhesive strips. The user removes the release tape to expose the adhesive strip of the article and places the article in the crotch portion of their undergarment. This prevents the article from moving out of position during regular use. Types of adhesive compounds that can be used are well known in the art.

The pH indicator polymer matrix is impregnated onto a substrate which can be made of many materials, for example, polypropylene, paper or cotton, polyester membranes and can be of many structures including of a membrane, fabric, mesh, gauze, thread, fiber and a sheet. The polymer matrix pH indicator contains a mixture of pre-formed polymer (such as cellulose), a plasticizer, a wetting agent, an ion-balance reagent and an indicator. In some cases it is preferable to add a solvent to the mixture. It is also possible that the polymer solution is polymerized after the addition of the plasticizer, the wetting agent, the ion-balance reagent and the indicator to the mixture. The mixture is applied to a substrate for example by dipping the substrate in the mixture or by spraying or spreading the mixture onto the substrate. The substrate with the applied mixture is allowed to dry. When dry, the polymeric pH indicator is bound to the substrate.

30

In one embodiment according to the present invention, a pH indicator is mixed with a polymer in a suitable solution and then applied to a substrate. According to specific embodiments, the polymer solution is prepared containing pre-formed polymer, plasticizer, a wetting agent, an ion-balance reagent, a solvent and an indicator.

In certain embodiments, suitable for use in direct contact with vaginal tissues, including a swab or strip in accordance with the present invention, it is important to select a biocompatible non-toxic polymer. The polymer used in the pH indicator polymer matrix solution suitable for a swab or strip may be selected from various non-toxic polymers, although cellulose polymers such as nitrocellulose (CAS 9004-70-0), cellulose acetate (CAS 9004-35-7) or ethyl cellulose (CAS 9004-57-3) are preferred. The polymer comprised 10% to 40% of the weight of the solution. Preferably, the polymer comprised 15% to 35% of the solution, more preferably the polymer comprised 20% to 33% of the solution, and most preferably the polymer comprised 24% to 28% by weight of the solution. As is clear to one skilled in the art, it is also possible to use a combination of suitable polymers when making one polymer solution.

Although any non-toxic suitable plasticizer can be used, bis-(2-ethylhexyl) sebacate (DOS, CAS 122-62-3), diethyl phthalate (DEP, CAS 84-66-2), dioctyl phthalate (DOP, CAS 117-81-7) are preferred. The plasticizer makes up 1% to 30% of the weight of the solution. It is preferred that the plasticizer makes up 2% to 25% of the solution, more preferred is that the plasticizer makes up 3% to 23% of the solution, and most preferred is that the plasticizer makes up 4% to 22% by weight of the solution. As is clear to one skilled in the art, it is also possible to use a combination of suitable plasticizers when making the polymer solution.

Although any suitable volatile wetting agent can be used, triethylene glycol (CAS 112-27-6), ethylene glycol (CAS 107-21-1), or 2-ethoxy ethanol (CAS 110-80-5) are preferred. The wetting agent makes up 10% to 40% of the weight of the solution. It is preferred that the wetting agent makes up 15% to 35% of the solution,

more preferred is that the wetting agent makes up 20% to 33% of the solution, and most preferred is that the wetting agent makes up 24% to 28% by weight of the solution. As is clear to one skilled in the art, it is also possible to use a combination of suitable wetting agents when making the polymer solution.

5

Although any suitable non-toxic ion-balance reagent can be used, Tridodecylmethyl ammonium chloride (TDMACl, CAS 7173-54-8) is preferred. The ion-balance reagent makes up 0.1% to 10% of the weight of the solution. It is preferred that the ion-balance reagent makes up 0.5 % to 8% of the solution, more preferred is that the ion-balance reagent makes up 0.8% to 7% of the solution, and most preferred is that the ion-balance reagent makes up 1% to 5% by weight of the solution. As is clear to one skilled in the art, it is also possible to use a combination of suitable ion-balance reagents when making the polymer solution.

15 The polymer used in the pH indicator polymer matrix solution preferably suitable for a pad, gauze, a fiber ball, but most preferably, as a sanitary napkin, diaper, panty shield, and interlabial structure can be selected from various preformed polymers, although cellulose polymers such as nitrocellulose (CAS 9004-70-0), cellulose acetate (CAS 9004-35-7) or ethyl cellulose (CAS 9004-57-3) are preferred. 20 The preformed polymer makes up 20% to 50% of the weight of the solution. Preferred is that the polymer makes up 25% to 45% of the solution, more preferred is that the polymer makes up 30% to 43% of the solution, and most preferred is that the polymer makes up 33% to 36% by weight of the solution. As is clear to one skilled in the art, it is also possible to use a combination of suitable preformed polymers when 25 making one polymer solution.

Although any suitable plasticizer can be used, bis-(2-butoxyethyl) adipate (BBPA, CAS 141-18-4), bis-(2-ethylhexyl) sebacate (DOS, CAS 122-62-3), diethyl phthalate (DEP, CAS 84-66-2) or dibutyl phthalate (DBP, CAS 84-74-2) are preferred. 30 The plasticizer makes up 15% to 40% of the weight of the solution. Preferred is that the plasticizer makes up 20% to 35% of the solution, more preferred is that the plasticizer makes up 21% to 31% of the solution, and most preferred is that the

plasticizer makes up 23% to 26% by weight of the solution. As is clear to one skilled in the art, it is also possible to use a combination of suitable plasticizers when making one polymer solution.

5           Although any suitable wetting agent can be used, triethylene glycol (CAS 112-27-6), ethylene glycol (CAS 107-21-1), or 2-ethoxy ethanol (CAS 110-80-5) are preferred. The wetting agent makes up 15% to 45% of the weight of the solution. Preferred is that the wetting agent makes up 21% to 40% of the solution, more preferred is that the wetting agent makes up 26% to 39% of the solution, and most preferred is that the wetting agent makes up 33% to 36% by weight of the solution. As is clear to one skilled in the art. it is also possible to use a combination of suitable wetting agents when making one polymer solution.

15           Although any suitable ion-balance reagent can be used, tricapyrylmethyl ammonium chloride (Aliquat 336, CAS 5137-55-3), tridodecylmethyl ammonium chloride (TDMAC, CAS 7173-54-8) or cetyltrimethyl ammonium chloride (CTAC, CAS 112-02-7) are preferred. The ion-balance reagent makes up 0.1% to 10% of the weight of the solution. Preferred is that the ion-balance reagent makes up 1 % to 8% of the solution, more preferred is that the ion-balance reagent makes up 3% to 7% of the solution, and most preferred is that the ion-balance reagent makes up 4% to 6% by weight of the solution. As is clear to one skilled in the art, it is also possible to use a combination of suitable ion-balance reagents when making one polymer solution.

25           It is to be understood that the actual amounts of the components of the solution are added so that the sum of weights of pre-formed polymer, plasticizer, wetting agent and ion-balance reagent is equal to 100%.

30           Following the preparation of the polymer solution, the desired indicator is added to the solution. Although any suitable indicator can be used, it is preferred that the indicator molecules have a negatively charged functional group such as acetate or sulfonate. Most preferably, the indicators used separately or in combination, are chosen from amongst indicators listed in Table I and in US Patent 5,897,834. The total

amount of indicator added is 0.05% to 5% of the weight of the polymer solution as described above. Preferred is that the indicator is 0.05% to 3% of the polymer solution, more preferred is that the indicator is 0.1% to 1% of the polymer solution, and most preferred is that the indicator is 0.2% to 0.5% of weight of the polymer solution.

5

Although any suitable solvent or mixture of solvents may be used for preparing the pH indicator polymer matrix solution, preferred solvents are Acetone, ethyl acetate or substantially volatile ethers such as diethyl ether, isopropyl ether, t-butyl methyl methyl ether or Tetrahydrofuran. The amount of solvent added to the solution is suitable for making any easily applied solution/indicator polymer matrix. Typically, 900 mg of preformed polymer is dissolved in between 30 ml and 110 ml of solvent, preferably between 50 ml and 100 ml solvent.

10

Once the pH indicator polymer matrix is ready, it is applied by suitable means to the substrate. The mixture may be applied on the substrate by spraying or spreading, or by dipping the substrate in the pH indicator polymer matrix. The substrate can be of many suitable materials known in the art such as polyester membranes or fabrics, polypropylene membranes, cellulose membranes, paper, cotton or linen. The structure of the substrate may be for example, a fiber, a mesh, gauze, a fabric or a membrane. It is preferred that the body of the secretion-monitoring article is in the form of a swab or a strip, a fiber ball, but most preferably, as a swab structure. The solvent of the mixture is allowed to evaporate.

20

The tip of the swab may be prepared by using a short strip, rolled on the stick of the swab, or by coating the tip of an integrated swab, where the tip consists of any screening fabric.

25

Although some of the compounds of the polymer solution are known as toxic according to their MSDS (material safety data sheet), once the mixture impregnate onto the substrate, for implementing the secretion monitoring article the final product is non toxic, non leaching and biocompatible with grade zero cytotoxicity, grade zero sensitization and grade zero irritation.

30

It is imperative that there be substantially no leaching of the pH indicator polymer matrix components from the substrate to which the indicator system is impregnated. The attachment of indicators to a substrate is well within the ability of one skilled in the art. Chemical compounds that are suitable for use as an indicator to be part of the polymer matrix indication system are sulfonephthaleine series or Azo dyes. Suitable indicators include Nitrazine yellow, thymol blue, bromthymol blue, xylenol blue, bromoxylenol blue, phenol red, m-cresol purple, chlorophenol red, bromcresol purple, alizarin, neutral red, and cresol red, see Table 1. A list of other suitable indicators can be found, for example, in US Patent 5,897,834. It is clear to one skilled in the art that the indicators specifically mentioned herein are just examples and any suitable indicators may be used.

Indicator	Aqueous pH transition range	Color change	CAS
1. Cresol Red	7.2 - 8.8	Yellow to reddish purple	1733-12-6
2. Alizarin	5.5 - 6.8	Yellow to violet	72-48-0
3. Bromcresol Purple	5.2 - 6.8	Yellow to purple	115-40-2
4. Chlorophenol Red	5.2 - 8.8	Yellow to red	4430-20-0
5. Nitrazine Yellow	6.0 - 7.2	Yellow to bright blue	5423-07-4
6. Bromthymol Blue	6.0 - 7.6	Yellow to blue	34722-90-2
7. Bromoxylenol Blue	6.0 - 7.6	Yellow to blue	40070-59-5
8. Neutral Red	6.8 - 8.0	Red to yellow	553-24--9
9. Phenol Red	6.8 - 8.2	Yellow to red	34487-61-1
10. Thymol Blue	8.0 - 9.2	Yellow to blue	81012-93-3
11. Xylenol Blue	8.0-9.6	Yellow to blue	125-31-5
12. m-Cresol purple	7.4-9.0	Yellow to purple	2303-01-7

15

The following examples are presented in order to more fully illustrate certain embodiments of the invention. They should in no way, however, be construed as limiting the broad scope of the invention. One skilled in the art can readily devise many variations and modifications of the principles disclosed herein without departing from the scope of the invention.

20

## EXAMPLES

***EXAMPLE 1: Preparation of the secretion-testing swab containing the Nitrazine yellow pH indicator polymer matrix.***

5

### **Method of Preparation**

#### **1) Polymer matrix indicator:**

**Step 1:** Dissolving cellulose acetate 24% to 28% in Acetone.

**Step 2:** Adding to the solution Dioctyl Phthalate 4%-22%.

10 **Step 3:** Adding to the solution Tridodecylmethyl ammonium chloride 1% to 5%.

**Step 4:** Adding to the solution 2-ethoxyethanol 24% to 28%.

**Step 5:** Adding to the solution Nitrazine Yellow 0.2% to 0.5% dissolved in double distilled water 24%-28%.

15 **Step 6:** Impregnating the solution to a swab or strip.

Figure 1 provides a visual example of an article in the form of a swab constructed with a polyester mash 1 and an indicator 2 connected to a swab handle 3. In Figure 2, the swab indicator 2 changes its color from yellow 5 to blue 4 when the pH is above 5. In cases where the buffer capacity of the secretion is low, the swab indicator 2 changes its color from yellow 5 to blue 4 in a dynamic pH range of 4.3-5.0.

20

***Example 2: Color change of the Nitrazine yellow pH indicator polymer matrix in different buffer capacities.***

25

100mM buffer phosphate citrate was prepared with seven different pH values. Each buffer was diluted to four different concentrations: 50, 20, 10 and 5 mM and the pH were adjusted using NaOH 1M or HCl 1M. A Nitrazine yellow polymer matrix of the invention was dipped in each buffer and the change in color was noted and represented by a numeric values as follows: 0 = Yellow; 1= Light Green; 2= Green; 3= Dark green. As revealed from the results summarized in Table 2 and Figure 3, when the solution has ionic concentration of 50mM or 100mM, the Nitrazine yellow

30

pH indicator polymer matrix changed the color from yellow to green/blue when the pH is above 5. In cases where the ionic concentration is lower than 20mM, the color change occurs in a dynamic pH range of 4.3-5.0.

5 **Table 2:**

pH ( $\pm 0.05$ )	100 mM	50 mM	20 mM	10 mM	5 mM
4.0	0	0	0	0	0
4.3	0	0	0	0	1
4.5	0	0	0	1	1
4.7	0	0	1	1	2
5.0	1	1	1	2	2
5.2	1	1	2	2	2
5.5	2	2	3	3	3

\*Color scale conversion: 0- Yellow; 1- Light Green; 2- Green; 3- Dark green;

10 A follow-up experiment was done using commercially available Nitrazine Paper (APOTHECON Inc., Princeton, New Jersey) with the same regime of pH buffer solutions. The Nitrazine Paper did not significantly change color in any of the pH buffer solutions. The results indicated that the commercially available Nitrazine Paper is not sensitive enough to distinguish differences in pH of any of the measured solutions.

15 An explanation for the fact that the Nitrazine yellow pH indicator polymer matrix of the present invention changed the color from yellow to green/blue when the pH is above 5 only in solutions with high buffer capacity while in cases where the solution possesses low buffer capacity, the color change occurs in a pH ranging between 4.3-5.0 is detailed hereinbelow.

20

The commercial Nitrazine yellow is a weak acid pH indicator, which when dissolved in water dissociate slightly and form the conjugate base described below. The chemical composition of the commercial Nitrazine paper is hydrophilic, so that it

contains some degree of ionic buffer capacity. Thus, the color change in the commercial Nitrazine yellow is independent on the buffer capacity of the solution and appears in pH 5 even in solutions with low buffer capacity.

5            Commercial Nitrazine yellow indicator:

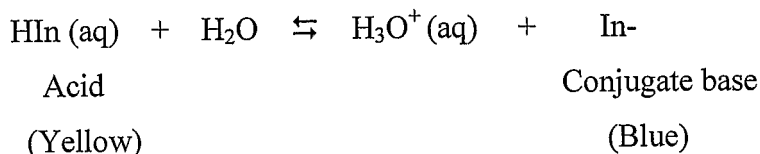

10            In contrast to the commercial indicator, the Nitrazine yellow pH indicator polymer matrix of the present invention is hydrophobic since it is composed of an organic substrate, thus it does not have ionic buffer capacity. Therefore, using the pH indicator polymer matrix of the present invention, it is possible to obtain color change in pH lower than 5 in solutions with low buffer capacity. Thus, the pH indicator is  
15 dependent on the buffer capacity of the solution.

The mechanism of color change of the Nitrazine yellow pH indicator polymer matrix is described in the following equation (Nitrazine yellow-NY):

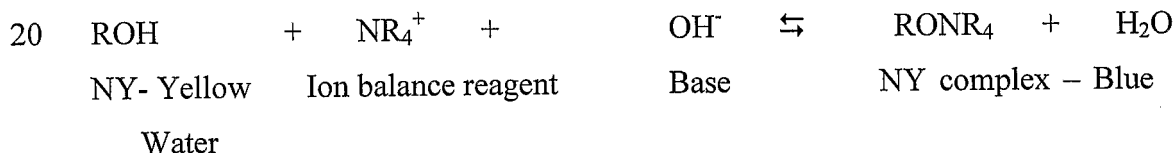

25            The reaction is in equilibrium and the color of the polymer depends on the ratio of free NY compared to the NY complex.

**Example 3: Assessment of the buffer capacity of vaginal secretions:**

30            In order to examine the buffer capacity of vaginal secretions, different buffer solutions were titrated with 0.1 N NaOH in comparison with vaginal secretions.

The vaginal secretions were collected with a sterile swab. The sterile swab was weighted on an analytical balance before and after secretion sampling. The secretion

was then diluted in ddH<sub>2</sub>O and titrated as the other buffer solutions with NaOH 0.1M. The dilution factor was taken in account in determining the buffer capacity of the vaginal secretion. The results of the titrations are summarized in Figure 4.

5           The results presented in Figures 3 and 4 demonstrate that the Nitrazine yellow pH indicator polymer matrix of the present invention has an advantage compared to the commercial Nitrazine paper in detecting vaginal infections having low buffer capacity characteristics. Specifically, infected vaginal secretions having pH between 4.3-4.9 and low buffer capacity will be detected only by the pH indicator polymer  
10       matrix of the present invention.

***Example 4: A panty shield capable to distinguish accurately between an amniotic fluid leak and wetness caused by urine incontinence***

15           The article can be a sticker or a pantyliner with an embedded indicator strip. The strip contains the pH indicator Nitrazine-yellow which has a pKa of 6.6 in aqueous solution.

Figure 5 is a general schematic perspective view of a panty shield (32) with a  
20       micro-porous top layer (34) with conically shaped holes (42) that by dripping by pipette (38) a drop (40) of any liquid, the drop will be absorbed(44) in one side of the micro-pours layer (34) and will not get out. Like any ordinary panty shield (32) it has an absorbent layer (36) and might have wings (46) to support the attachment to the woman's panty.

25           Figure 5A is a schematic top view of a different embodiment of the secretion-monitoring article (1) of the present invention with pH indicator polymer matrix device (2) on top of the absorbent layer (3).

Figure 5B is a schematic top view of a different embodiment of the secretion-monitoring article (1) of the present invention with option to pull out the pH indicator  
30       polymer matrix device (2) by the tail (4) that tears the pH indicator polymer matrix device (2) from the absorbent layer (3) along the perforating line (5) to accelerate the reverse reaction time of the color change.

Figure 5C is a schematic top view of the secretion-monitoring (1) article of the present invention with option to pull out the pH indicator polymer matrix device (2) by tail (4), wherein the pH indicator is stained (6) after contact with vaginal secretion of pH above 5 or with low buffer capacity, or urine before reverse reaction of the color back to yellow.

Figure 5D is a schematic top view of the pulled out stained (6) pH indicator along the perforated line (5) of the pH indicator polymer matrix device (2) including the tail (4) after contact with vaginal secretion of pH above 5 or with low buffer capacity, or urine before reverse reaction of the color back to yellow.

Figure 5E is a schematic top view of a different embodiment of the open drying box (11) that accelerate the reverse reaction time of the color change due to urine stain back to yellow in less than ten minutes by felt (7) bottom layer, and the position of the box top cover (8) that has ventilating holes (9) that allows the vapor to get out from the drying box (11) after closing the top cover (8) and lock it by the locking pins (10) to hold the pH indicator polymer matrix device in its place between the top cover (8) and the felt (7).

Figure 5F is a schematic top view of the pH indicator polymer matrix device (2) with the tail (4) inside the closed drying unit (11) after closing the top cover (8) and lock its place between the top cover (8) with the ventilating holes (9) and the felt (7).

Reaction of the indicator with amniotic fluid (pH 6-8) changes the color from yellow to stable dark blue. Reaction of the indicator with urine (pH 5-8) changes the color to fading green or fading turquoise. Urine with lower pH 5-5.5 doesn't change the indicator color.

The difference between the color reaction of the indicator with amniotic fluid and with urine consists of two parameters: the chemical composition of the fluids and the indicator's polymer chemical structure.



ammonium ion in the medium.

For example: in 100mM buffer solution that contains 25mM ammonium ion the concentration of the ammonium is in two orders of magnitude higher than the ion balance reagent in the polymer. These differences govern the turquoise color in solution and the fading color on drying.

Urine contains ammonium ions in concentration of 30 – 50 mM; amniotic fluid doesn't contain any substantial amount of ammonium ions, thus causing no fading influence as urine does.

10      Method of Preparation:

**Step 1:** To a 5 ml of Acetone add 150 mg Cellulose acetate, 107 µl Dibutylphthalate, 23µl Aliquat, 150 µl 2-Ethoxy ethanol and 2.4 mg Nitrazine yellow dissolved in 150 µl DDW.

**Step 2:** Stir the mixture for few minutes to complete dissolving.

15      **Step 3:** Coat a polyester monofilament screening fabric with the polymer solution to give the desired product.

***Example 5: A device able to distinguish accurately between normal urine and infected urine***

20

The reoccurrence of urinary tract infections in certain patients present the need to quickly and easily diagnose whether the patient has another urinary tract infection. Presently, to determine if a patient has a urinary tract infection they must make an appointment to visit a doctor. Furthermore, if the patient is susceptible to the reoccurrence of urinary tract infections they must make periodic visits to the doctor's office to ensure that the infection has not reoccurred. Having a device that would allow the user to determine if they had a urinary tract infection again would minimize stress and time consumed by visits to the doctor's office and result in quicker diagnosis of the infection, resulting in a reduction in pain suffered by the patient and a more timely treatment of the infection.

30

The article in this example is a diaper or a panty liner with an indicator that

can distinguish between normal urine and infected urine. The user wears the article so that urine can come in contact with the article. The reaction of the indicator with urine (pH 5-8) changes the color from yellow to green or turquoise. The drying process of the indicator strip at room temperature is short (10 minutes). When normal  
5 urine comes in contact with the indicator strip the color changes fade while drying. The color change is completely reversible and the strip becomes yellow again. On the other hand when infected urine comes in contact with the indicator strip the color changes to green or turquoise and stay constant while drying.

10 The reversibility of the color changes depends on two different factors of the environment:

1. Chemical environment:

- a. The pH level of the fluid – pH level higher than the pKa gives a stable color change.
- 15 b. Buffer capacity of the solution –
- c. Ammonium salts content in the solution .

2. Biological environment:

- a. Protein presence in urine gives a stable color change and the reaction is not reversible.

20 Infected urine provides a stable color change to the indicator, which color change is not reversible. Furthermore, bacteria presence in vaginal secretion fluid also gives a stable color change so that the color change is not reversible.

25 While the present invention has been particularly described, persons skilled in the art will appreciate that many variations and modifications can be made. Therefore, the invention is not to be construed as restricted to the particularly described embodiments, rather the scope, spirit and concept of the invention will be more readily understood by reference to the claims which follow.

30

**CLAIMS**

1. A secretion-monitoring article for the identification of secreted biological fluids comprising: a substrate for absorbing a biological fluid secreted from a person, and a biocompatible pH indicator polymer matrix comprising at least one pH determining reagent and a pre-formed polymer, the pH indicator polymer matrix reacts with biological fluids that have low buffer capacity differently than with bodily fluids that have normal buffer capacity, wherein the secreted biological fluids contact said pH indicator polymer matrix for possible reaction therewith to identify that said secreted biological fluids have a pH level that exceeds a determined range of pH levels dependent on the buffer capacity of said biological fluids.
2. The article of claim 1, wherein the secretion-monitoring article is suitable for the identification of vaginal secretions.
3. The article of claim 2, wherein the secretion-monitoring article is suitable for identifying secretions associated with bacterial vaginosis, Trichomonas, amniotic fluid, parasite infections, fungal infections, or yeast infections.
4. The article of claim 1, wherein the pH indicator polymer matrix has an immediate and stable color response following the contact of the secreted biological fluids with said pH indicator polymer matrix.
5. The article of claim 1, wherein the pH indicator polymer matrix comprises a polymer selected from: nitrocellulose, cellulose acetate and ethyl cellulose.
6. The article of claim 1, wherein the pH determining reagent having negatively charged functional groups.
7. The article of claim 6, wherein the pH determining reagent is selected

from: Nitrazine yellow, thymol blue, bromthymol blue, xylenol blue, bromoxylenol blue, phenol red, m-cresol purple, chlorophenol red, bromcresol purple, alizarin, neutral red, and cresol red.

- 5           8.       The article of claim 7, wherein the pH determining reagent is Nitrazine yellow.
9.       The article of claim 1, wherein the article is in the form of a swab, a gauze, a panty shield, a hygienic napkin, or a diaper.
- 10          10.       The article of claim 1, wherein the pH indicator polymer matrix further comprises: a solvent, a plasticizer, a volatile wetting agent, and an ion-balance reagent.
- 15          11.       The article of claim 10, wherein the pre-formed polymer in an amount of about 10 to 40%; the plasticizer in an amount of about 1 to 30%; the volatile wetting agent in an amount of about 10 to 40%; the ion-balance reagent in an amount of about 0.1 to 10%; and the pH determining reagent in an amount of about 0.05 to 5%; wherein the percents are weight percents based on the total
- 20           weight of the mixture and the total weight of the mixture equals 100%.
12.       The article of claim 11, wherein the pre-formed polymer is in an amount of about 24 to 28%, the plasticizer is in an amount of about 4 to 22%, the volatile wetting agent is in an amount of about 24 to 28% the ion-balance
- 25           reagent is in an amount of about 1 to 5%, and the pH determining reagent is in an amount of 0.2 to 0.5%.
13.       The article of claim 10, wherein the solvent is in an amount sufficient for dissolving the polymer.
- 30          14.       The article of claim 13, wherein the solvent is selected from: acetone, ethyl acetate, diethyl ether, isopropyl ether, t-butyl methyl ether and

Tetrahydrofuran.

15. The article of claim 13, wherein about 30 to 110 ml of the solvent is added for each 900 mg of pre-formed polymer.

5

16. The article of claim 11, wherein the pre-formed polymer is selected from: cellulose, nitrocellulose, cellulose acetate and ethyl cellulose.

10

17. The article of claim 11, wherein the plasticizer is selected from: bis-(2-ethylhexyl) sebacate, diethyl phthalate, dioctyl phthalate, bis-(2-butoxyethyl) adipate and dibutyl phthalate.

15

18. The article of claim 11, wherein the ion-balance reagent is Tridodecylmethyl ammonium chloride, tricaprylmethyl ammonium chloride and cetyltrimethyl ammonium chloride.

19. The article of claim 11, wherein the volatile wetting agents are selected from triethylene glycol, ethylene glycol, and 2-ethoxy ethanol.

20

20. A method for monitoring the health condition of a person comprising: positioning the secretion-monitoring article of claim 1 to absorb fluids secreted from the vagina of a female, and inspecting the color of the pH indicator polymer matrix, wherein if the secreted biological fluids have a pH level that exceeds a determined range of pH levels dependent on the buffer capacity of said biological fluids, than said pH indicator polymer matrix changes color upon contact with said secreted biological fluids.

25

21. The method of claim 20, wherein the article is in the form of a swab, a gauze, a panty shield, a hygienic napkin, or a diaper.

30

22. A method for identifying vaginal secretions comprising: positioning the secretion-monitoring article of claim 1 to absorb fluids secreted from the

vagina of a female, and inspecting the color of the pH indicator polymer matrix, wherein if the secreted biological fluids have a pH level that exceeds a determined range of pH levels depending on the buffer capacity of said biological fluids, than said pH indicator polymer matrix changes color upon contact with the secreted biological fluids, thereby identifying said vaginal secretions.

23. The method of claim 22, wherein the vaginal secretions are associated with bacterial vaginosis, amniotic fluid, parasite infections, fungal infections, or yeast infections.

24. The method of claim 23, wherein the accuracy of identifying bacterial vaginosis is higher than 95%.

25. The method of claim 22, wherein the article is in the form of a swab, a gauze, a panty shield, a hygienic napkin, or a diaper.

26. A method for preparing the secretion-monitoring article of claim 1 comprising: applying the pH indicator polymer matrix onto the substrate, and allowing said pH indicator polymer matrix to dry, so that said pH indicator polymer matrix is attached to said substrate.

27. The method of claim 26, wherein the pH indicator polymer matrix is applied onto the substrate by spreading or spraying said pH indicator polymer matrix on said substrate or by dipping said substrate in said pH indicator polymer matrix.

28. The method of claim 26, wherein the article is in the form of a swab, a gauze, a panty shield, a hygienic napkin, or a diaper.

29. A secretion-monitoring article for the identification of bacterial vaginosis comprising: a substrate for absorbing vaginal secretions, and a

biocompatible pH indicator polymer matrix comprising at least one pH determining reagent and a pre-formed polymer, the pH indicator polymer matrix reacts with biological fluids that have low buffer capacity differently than with bodily fluids that have normal buffer capacity, wherein the vaginal secretions contact said pH indicator polymer matrix for possible reaction therewith to identify that said vaginal secretions have a pH level that exceeds a determined range of pH levels dependent on the buffer capacity of said biological fluids.

5

30. The article of claim 29, wherein the article is in the form of a swab, a gauze, a panty shield, a hygienic napkin, or a diaper.

10

31. The article of claim 29, wherein the pH indicator polymer matrix comprises a polymer selected from: nitrocellulose, cellulose acetate and ethyl cellulose.

15

32. The article of claim 29, wherein the pH determining reagent having negatively charged functional groups.

20

33. The article of claim 32, wherein the pH determining reagent is selected from: Nitrazine yellow, thymol blue, bromthymol blue, xylenol blue, bromoxylenol blue, phenol red, m-cresol purple, chlorophenol red, bromcresol purple, alizarin, neutral red, and cresol red.

25

34. The article of claim 33, wherein the pH determining reagent is Nitrazine yellow.

30

35. The article of claim 29, wherein the pH indicator polymer matrix further comprising: a solvent, a plasticizer, a volatile wetting agent, and an ion-balance reagent.

36. A secretion-monitoring article for the identification of secreted biological fluids comprising: a swab or strip for absorbing a biological fluid

secreted from a person, and a biocompatible pH indicator polymer matrix comprising at least one pH determining reagent and a pre-formed polymer, the pH indicator polymer matrix reacts with biological fluids that have low buffer capacity differently than with bodily fluids that have normal buffer capacity, wherein the secreted biological fluids contact said pH indicator polymer matrix for possible reaction therewith to identify that said secreted biological fluids have a pH level that exceeds a determined range of pH levels dependent on the buffer capacity of said biological fluids.

10 37. A secretion-monitoring article for the identification of amniotic leak comprising: a substrate for absorbing vaginal secretions, and a biocompatible pH indicator polymer matrix comprising at least one pH determining reagent and a pre-formed polymer, the pH indicator polymer matrix reacts with biological fluids that have low buffer capacity differently than with bodily fluids that have normal buffer capacity, wherein the vaginal secretions contact said pH indicator polymer matrix for possible reaction therewith to identify that said vaginal secretions have a pH level that exceeds a determined range of pH levels dependent on the buffer capacity of said biological fluids.

20 38. A secretion-monitoring article for the identification of secreted biological fluids comprising: a substrate for absorbing a biological fluid secreted from a person, and a pH indicator polymer matrix comprising at least one pH determining reagent and a polymer, wherein the pH indicator polymer matrix changes color at a lower pH in the presence of biological fluids that have low buffer capacity than with bodily fluids that have normal buffer capacity, wherein the secreted biological fluids contact said pH indicator polymer matrix for possible reaction therewith to identify that said secreted biological fluids have a pH level that exceeds a determined range of pH levels dependent on the buffer capacity of said biological fluids.

30

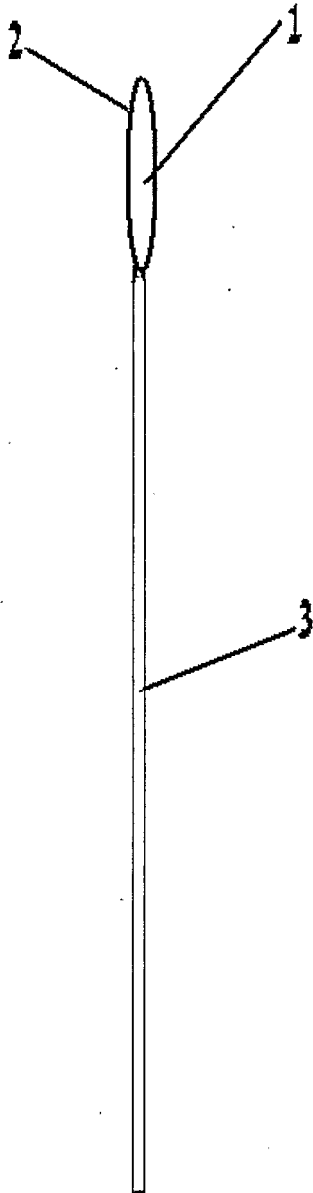

Figure 1

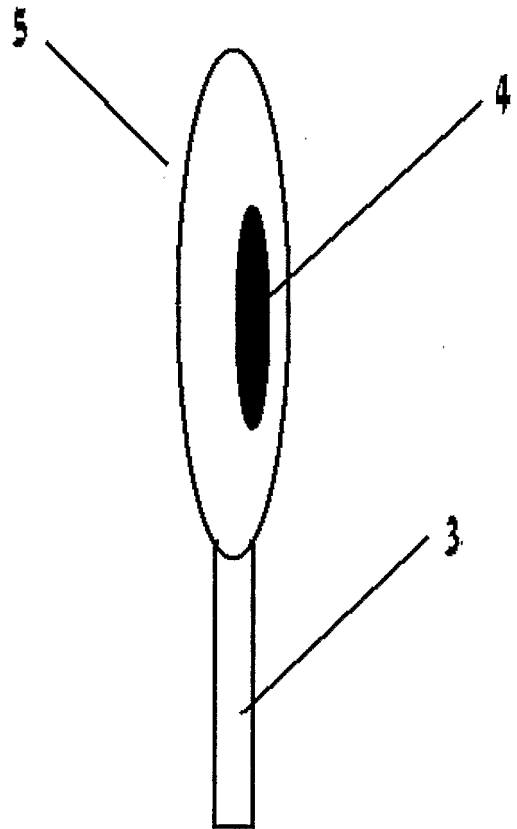

Figure 2

Figure 3

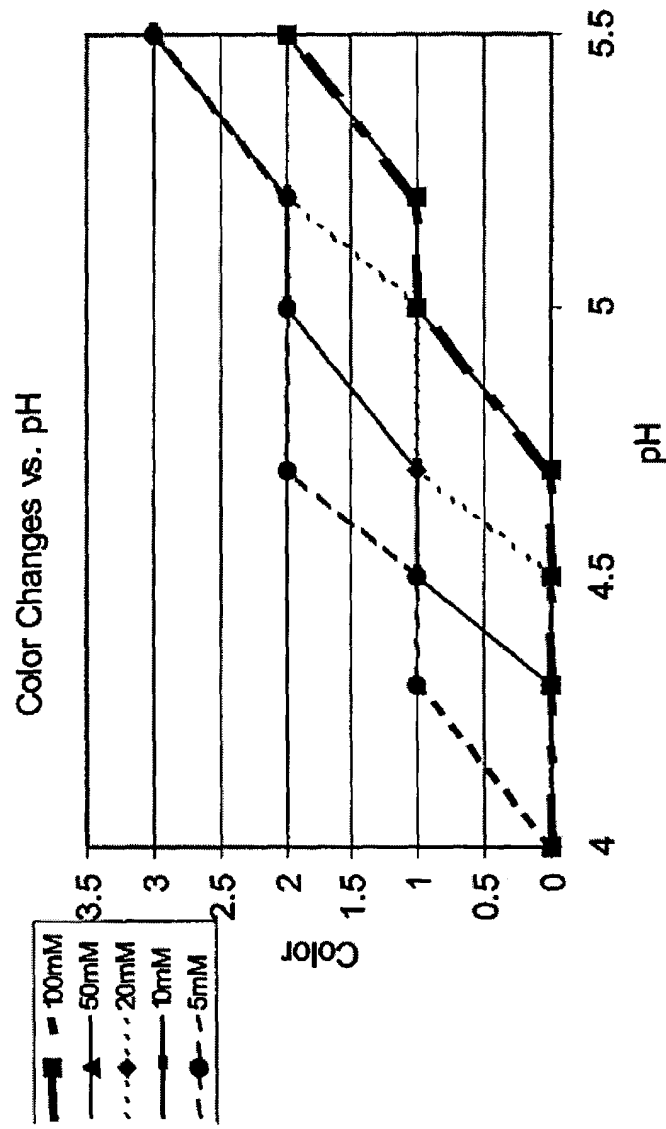

Figure 4

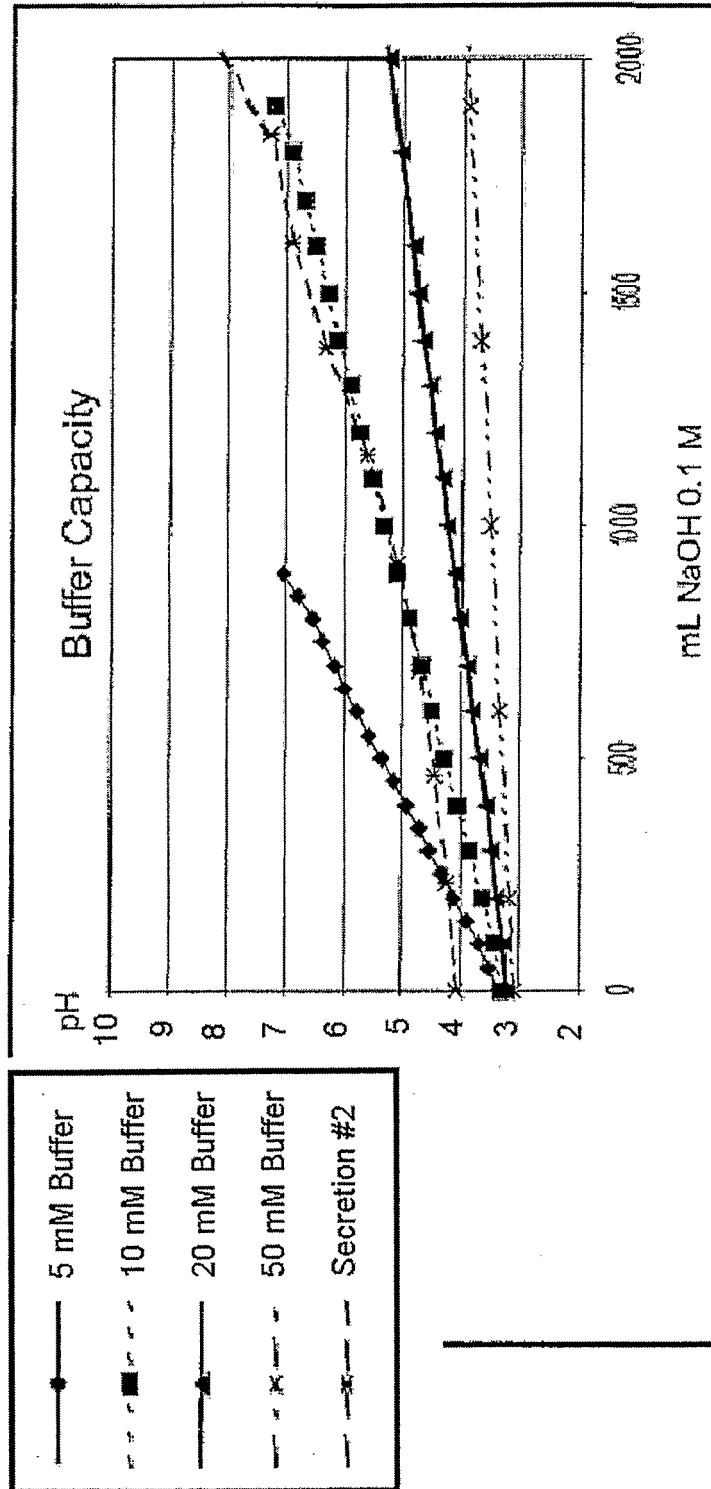
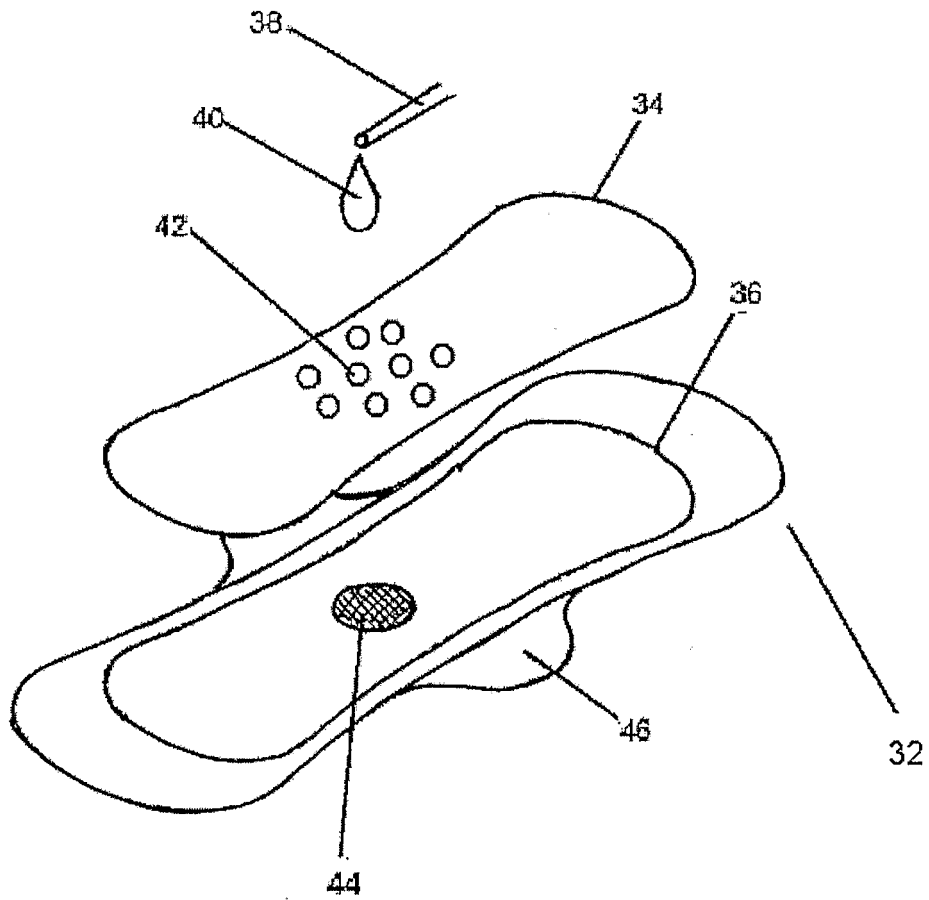
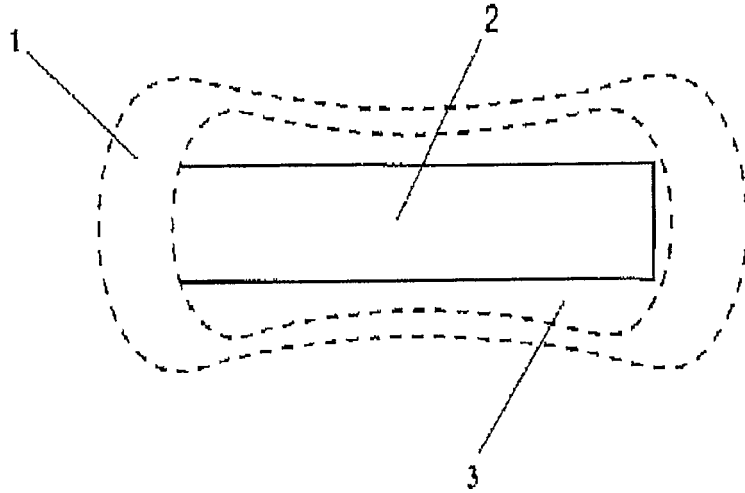

Figure 5



**Figure 5A**



**Figure 5B**

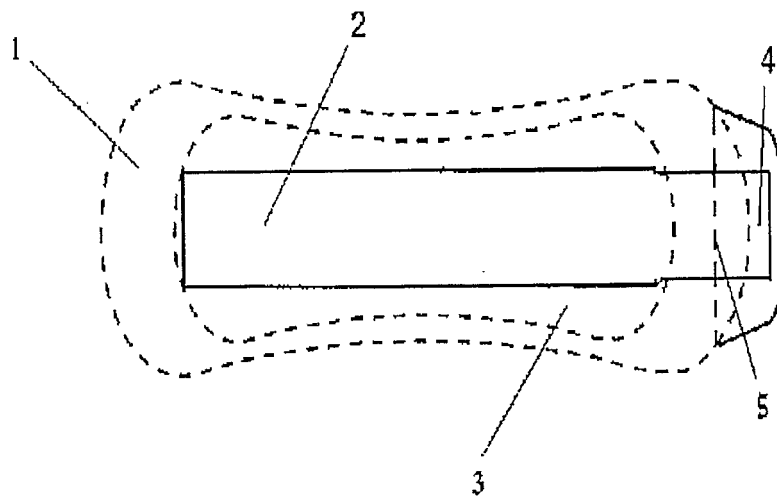

**Figure 5C** 6/7

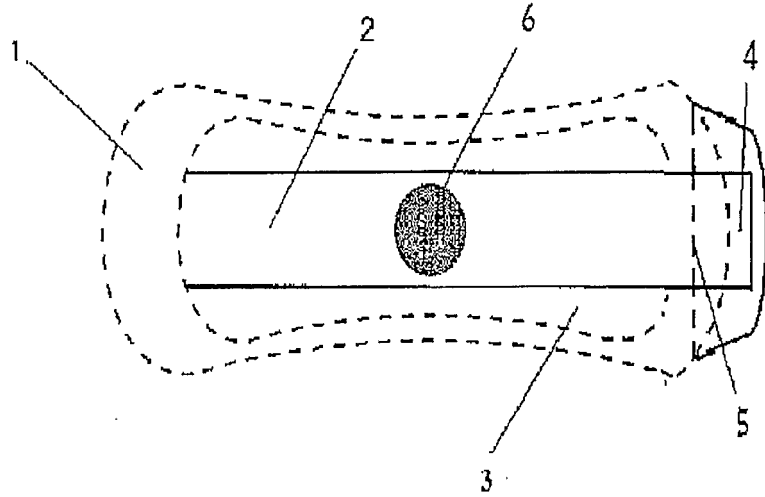

**Figure 5D**

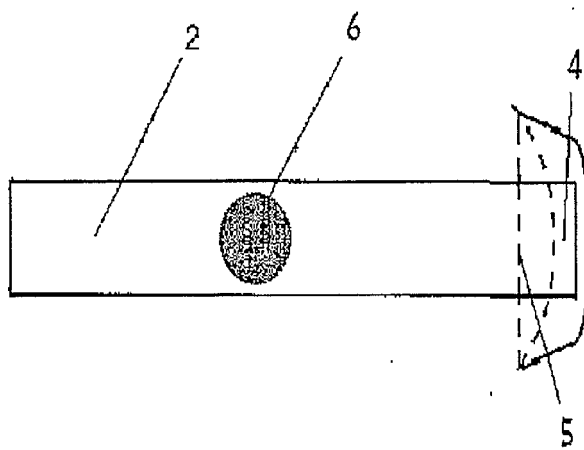

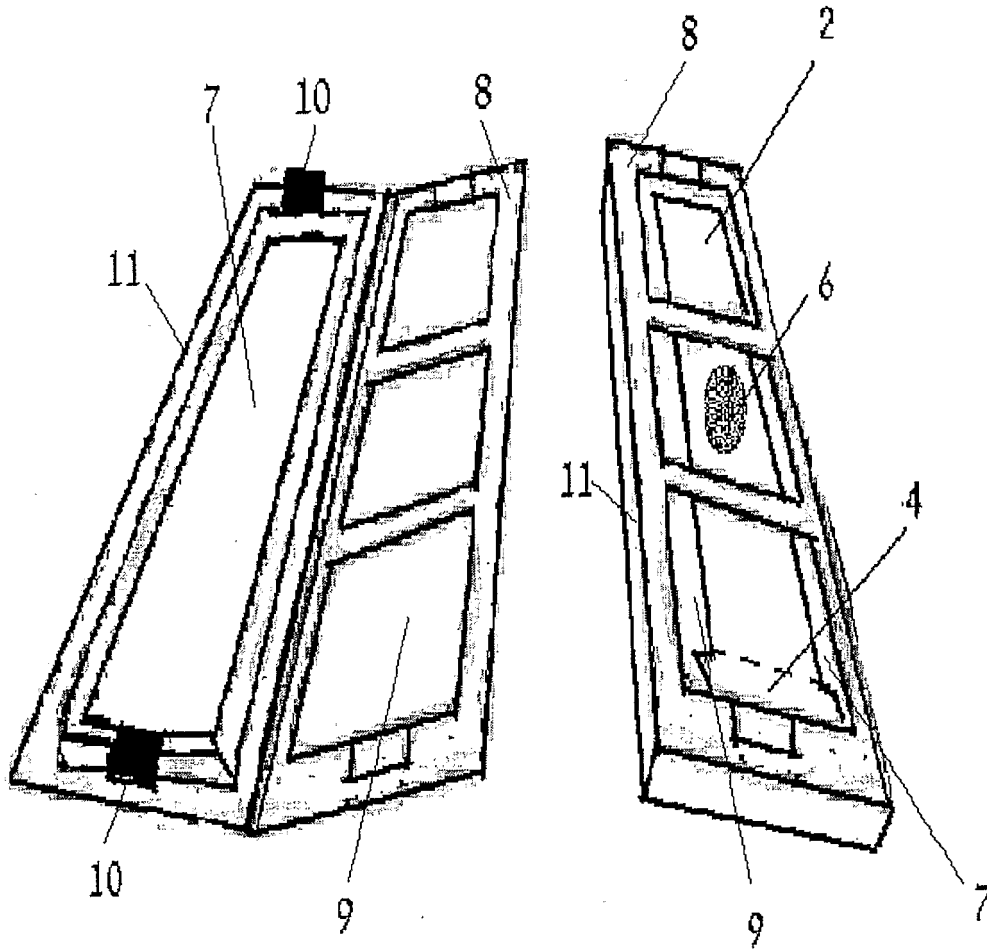

Figure 5E

Figure 5F

专利名称(译)	分泌物测试文章		
公开(公告)号	<a href="#">EP1565140A2</a>	公开(公告)日	2005-08-24
申请号	EP2003769878	申请日	2003-11-02
[标]申请(专利权)人(译)	科蒙森斯公司		
申请(专利权)人(译)	COMMON SENSE LTD.		
当前申请(专利权)人(译)	COMMON SENSE LTD.		
[标]发明人	KRITZMAN AMNON NACHSHON NITSA G BECHAR YAEL		
发明人	KRITZMAN, AMNON NACHSHON, NITSA, G. BECHAR, YAEL		
IPC分类号	A61B5/00 A61F13/15 C12M1/26 C12Q1/00 C12Q1/04 C12Q1/58 G01N G01N21/00 G01N33/52 G01N33/543		
CPC分类号	A61F13/42 A61B5/14539 A61B10/0048 A61B10/007 A61B2010/0074 A61F2013/427 A61F2013/8497 C12Q1/04 G01N31/221 G01N33/528 G01N33/54366 Y10T436/173845		
优先权	10/285499 2002-11-01 US		
其他公开文献	EP1565140A4		
外部链接	<a href="#">Espacenet</a>		

#### 摘要(译)

本发明教导了pH指示剂聚合物基质和使用它们鉴定阴道分泌物的方法。公开了一种用于鉴定分泌的生物流体的分泌物监测制品，其具有用于吸收人体分泌的生物流体的基质，以及包含至少一种pH测定试剂的生物相容性pH指示剂聚合物基质，所述pH测定试剂与具有低缓冲能力的生物流体反应。与具有正常缓冲能力的体液不同。