

(19) World Intellectual Property Organization
International Bureau



(43) International Publication Date
30 October 2003 (30.10.2003)

PCT

(10) International Publication Number
WO 03/088829 A2

(51) International Patent Classification⁷: A61B 3/16, 8/06

(21) International Application Number: PCT/GB03/01729

(22) International Filing Date: 22 April 2003 (22.04.2003)

(25) Filing Language: English

(26) Publication Language: English

(30) Priority Data:
0208945.6 19 April 2002 (19.04.2002) GB

(71) Applicant (for all designated States except US): THE
QUEEN'S UNIVERSITY OF BELFAST [GB/GB];
University Road, Belfast BT7 1NN (GB).

(72) Inventor; and

(75) Inventor/Applicant (for US only): MCVEIGH, Gary,
Eugene [GB/GB]; 14A Adelaide Park, Belfast BT9 6FX
(GB).

(74) Agent: MURGITROYD & COMPANY; Scotland
House, 165-169 Scotland Street, Glasgow G5 8PL (GB).

(81) Designated States (national): AE, AG, AL, AM, AT, AU,
AZ, BA, BB, BG, BR, BY, BZ, CA, CH, CN, CO, CR, CU,
CZ, DE, DK, DM, DZ, EC, EE, ES, FI, GB, GD, GE, GH,
GM, HR, HU, ID, IL, IN, IS, JP, KE, KG, KP, KR, KZ, LC,
LK, LR, LS, LT, LU, LV, MA, MD, MG, MK, MN, MW,
MX, MZ, NO, NZ, OM, PH, PL, PT, RO, RU, SC, SD, SE,
SG, SK, SL, TJ, TM, TN, TR, TT, TZ, UA, UG, US, UZ,
VC, VN, YU, ZA, ZM, ZW.

(84) Designated States (regional): ARIPO patent (GH, GM,
KE, LS, MW, MZ, SD, SL, SZ, TZ, UG, ZM, ZW),
Eurasian patent (AM, AZ, BY, KG, KZ, MD, RU, TJ, TM),
European patent (AT, BE, BG, CH, CY, CZ, DE, DK, EE,
ES, FI, FR, GB, GR, HU, IE, IT, LU, MC, NL, PT, RO,
SE, SI, SK, TR), OAPI patent (BF, BJ, CF, CG, CI, CM,
GA, GN, GQ, GW, ML, MR, NE, SN, TD, TG).

Published:

— without international search report and to be republished
upon receipt of that report

For two-letter codes and other abbreviations, refer to the "Guidance Notes on Codes and Abbreviations" appearing at the beginning of each regular issue of the PCT Gazette.

(54) Title: VASCULAR IMPEDANCE MEASUREMENT APPARATUS

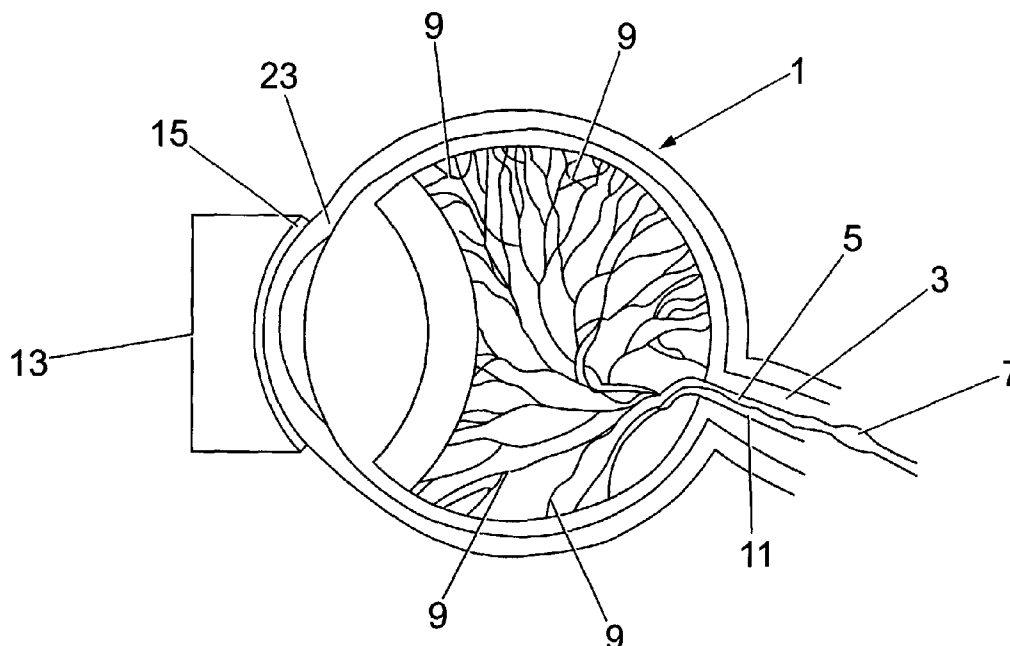

(57) Abstract: Apparatus and method for the measurement of vascular impedance of the ocular circulation *in vivo* are provided. A pressure pulse waveform is recorded from measurement of the intraocular pressure, and the velocity profile of blood flow in the retinobulbar circulation is recorded. These two readings are used to calculate the vascular impedance modulus.



WO 03/088829 A2

1 Vascular Impedance Measurement Apparatus

2

3 The present invention relates to apparatus for
4 measuring vascular impedance.

5

6 The complications of cardiovascular disease
7 represent the leading cause of morbid and mortal
8 events in Western society. At present, diagnostic
9 procedures are designed to assess the extent and
10 severity of blood vessel damage when symptoms
11 present or with the occurrence of vascular events.
12 The diagnostic challenge is to detect abnormal
13 structure and function in the vascular system at an
14 early pre-clinical stage. The ability to detect and
15 monitor sub-clinical arterial damage has the
16 potential to refine cardiovascular risk
17 stratification and enable early intervention to
18 prevent or attenuate disease progression.

19

20 Traditionally, the arterial circulation has been
21 considered a steady-flow system characterised by

1 mean arterial pressure that represents the product
2 of cardiac output and total peripheral resistance.

3

4 The pulsatile component of pressure is determined by
5 the pattern of left ventricular ejection and the
6 stroke volume. The compliance characteristics of the
7 arterial circulation has been largely ignored in
8 prior haemodynamic studies.

9

10 The importance of assessing arterial wall integrity
11 has been highlighted by studies demonstrating that a
12 reduction in the pulsatile function or compliance
13 characteristics of large arteries represents a
14 powerful independent risk factor for future
15 cardiovascular events. Accumulating evidence
16 suggests that abnormalities in the pulsatile
17 characteristics of arteries occur early in disease
18 processes associated with increased cardiovascular
19 risk. Importantly, impaired pulsatile arterial
20 function is recognised as an independent predictor
21 of risk for vascular events in patients with various
22 disease states including coronary heart disease,
23 congestive heart failure, hypertension and diabetes
24 mellitus.

25

26 Studies relating outcome to abnormalities in
27 pulsatile function have focused on large arteries,
28 although analysis of arterial pressure pulse
29 waveforms suggest that the earliest abnormalities in
30 arterial structure and function resides in the
31 microcirculation.

32

1 The study of this section of the vasculature has
2 been hindered by the lack of a non-invasive,
3 reproducible and repeatable technique capable of
4 assessing the compliance characteristics or
5 pulsatile function of small arteries and arterioles.

6
7 Physiologically, the impedance load or opposition to
8 flow presented by the circulation is measured
9 invasively by analysing the altered pressure/flow
10 relationships and pulse contour parameters produced
11 through the effects of disease on the structural and
12 functional components of the arterial system. Input
13 impedance relates simultaneously recorded pressure
14 and flow waveforms under specific mathematical
15 conditions. The haemodynamic properties of the
16 system can be quantified as the impedance concept
17 permits the heart and arteries to be considered
18 separately and their interaction understood as a
19 function of pump and load properties. As pressure
20 and flow waves are periodic and continuous, Fourier
21 series methods can be used to generate the impedance
22 function. The modulus at each harmonic in the
23 Fourier series is the ratio of the pressure modulus
24 to the flow modulus at that harmonic and the phase
25 at each harmonic is the difference between pressure
26 phase and flow phase at the same harmonic. As the
27 impedance of a vascular bed varies with frequency,
28 complete specification of pulsatile pressure and
29 flow relationships takes the form of the spectrum of
30 moduli and phase angles versus frequency⁵.

31

1 Characteristic impedance (the inverse of arterial
2 compliance) defines the relationship between
3 pressure and flow in an artery or arterial network
4 when pressure and flow waves are not influenced by
5 wave reflections. These conditions do not exist in
6 the arterial system and the input impedance values
7 oscillate around the characteristic impedance value
8 because of wave reflection. Wave reflections are
9 known to exert their greatest influence on impedance
10 moduli at low frequencies. For higher frequencies,
11 the input impedance approaches the characteristic
12 impedance which has been estimated in prior
13 haemodynamic studies as the arithmetic mean of input
14 impedance moduli above 2-4 Hz.

15

16 In the prior art, detailed studies of arterial
17 pressure and flow are only possible through the use
18 of invasive techniques. Such techniques cannot be
19 used to monitor changes in the circulatory system of
20 a patient over time because of the dangers to health
21 posed by these techniques.

22

23 In accordance with a first aspect of the present
24 invention there is provided apparatus for the
25 measurement of vascular impedance of the ocular
26 micro circulation *in vivo*, the apparatus comprising
27 intra-ocular pressure measurement means, from which
28 a pressure pulse waveform is calculable and blood
29 velocity profile measurement means for measuring the
30 linear blood flow velocity in the retrobulbar
31 circulation, means for calculating a vascular

1 impedance modulus from the pressure pulse waveform
2 and the linear blood flow velocity.

3

4 Preferably the intra-ocular pressure measurement
5 means is suitable for measuring the maximum and
6 minimum pressure values of the pulse profile to
7 calculate a mean intra-ocular pressure.

8

9 Preferably, the apparatus is suitable for measuring
10 how the pressure pulse waveform and the linear blood
11 flow velocity vary over the period of a respiratory
12 cycle.

13

14 Preferably, the means for calculating the vascular
15 impedance modulus takes into account the

16

17 Preferably, a solid state transducer is used to
18 measure intra-ocular pressure.

19

20 Preferably, the solid state transducer operates in
21 conjunction with a suitable telemetry system to
22 process the data.

23

24 Optionally, an ocular pneumotonometer is used to
25 measure intra-ocular pressure.

26

27 Preferably the blood velocity profile measurement
28 means is an ultrasound device.

29

30 Preferably the ultrasound device is a doppler
31 ultrasound imager.

32

1 Preferably, the apparatus further comprises motion
2 picture generation means to produce moving images of
3 an artery.

4

5 Preferably, the moving images are capable of being
6 used to ensure that a user of the apparatus can
7 accurately identify the location of an artery.

8

9 Preferably the change in the pulsatile intra-ocular
10 pressure waveform and the linear blood flow velocity
11 are measured sequentially.

12

13 Preferably, the means for calculating the vascular
14 impedance modulus comprises obtaining the fourier
15 transform of the intra-ocular pressure pulse
16 waveform and the linear blood flow velocity and
17 dividing the transformed values of the pulsatile
18 change in the intra-ocular pressure pulse by the
19 transformed retrobulbar blood flow velocity.

20

21 Preferably the pulsatile change in intra-ocular
22 pressure has a phase associated therewith.

23

24 Preferably the intra-ocular blood velocity has a
25 phase associated therewith.

26

27 In accordance with a second aspect of the present
28 invention there is provided a method for the
29 measurement of vascular impedance of the ocular
30 micro circulation *in vivo*, the method comprising the
31 steps of: measuring the intra-ocular pressure pulse
32 waveform of the ocular network;

1 measuring the linear blood flow velocity in the
2 retrobulbar circulation; and
3 calculating a vascular impedance modulus from the
4 intra ocular pressure pulse waveform and the linear
5 blood flow velocity waveform.

6

7 Preferably, the pressure pulse waveform and the
8 linear blood flow velocity are measured over the
9 period of a respiratory cycle, and their variation
10 therewith is measured.

11

12 Preferably, the variations are used in the
13 calculation of the vascular impedance modulus.

14

15 Preferably, the method further comprises the steps
16 of recording moving images of an artery.

17

18 Preferably, the moving images are used to accurately
19 identify the location of an artery.

20

21 Preferably, the change in the pulsatile intra-ocular
22 pressure waveform and the linear blood flow velocity
23 are measured sequentially.

24

25 Preferably, the step of calculating the vascular
26 impedance modulus comprises the steps of;
27 obtaining the fourier transform of the intra-ocular
28 pressure pulse waveform and the linear blood flow
29 velocity and dividing the transformed values of the
30 pulsatile change in the intra-ocular pressure pulse
31 by the transformed retrobulbar blood flow velocity.

32

1 The invention will now be described by way of
2 example only with reference to the accompanying
3 drawings in which:

4

5 Fig. 1 is a diagram of an eye having means for
6 measuring the intra-ocular pressure using the
7 principle of applanation tonometry at the front of
8 the eye;

9

10 Fig. 2 is a diagram of an eye having means for
11 measuring the linear flow velocity by interrogating
12 the retrobulbar circulation from the front of the
13 eye;

14

15 Fig. 3 is a graph of the periodic pressure signal as
16 measured using the present invention plotted against
17 time;

18

19 Fig. 4 is a graph of the periodic velocity signal as
20 measured using the present invention plotted against
21 time;

22

23 Fig. 5 is a graph of impedance modulus plotted
24 against frequency; and

25

26 Fig. 6 is a graph of phase plotted against
27 frequency.

28

29 Figs. 1 and 2 show a first embodiment of the present
30 invention. Figs. 1 and 2 are diagrams showing some
31 features of the human eye 1. These include the
32 optic nerve 3, the ophthalmic artery 5, a bolus of

1 blood contained in the ophthalmic artery 5
2 positioned outside the ocular vascular network 9.
3 The vein 11 is also shown.

4

5 Fig. 1 also shows the means for measuring the intra-
6 ocular pressure 13, provided, in this example by a
7 tonometer system applanated to the cornea 23.

8

9 Fig. 2 shows means for measuring the linear blood
10 flow velocity in the retrobulbar circulation 17,
11 connected to the front of the eye. This is an
12 ultrasonic device that is placed on the eyelid
13 19, the eyelid 19 being covered with a gel 21 to
14 ensure that the ultrasound device is properly
15 coupled to the eye 1. This device measures the
16 linear velocity of the bolus of blood 7 in the
17 ophthalmic artery 5.

18

19

20 The tonometer system 13 used can employ continuous
21 airflow pneumotometry (for example using an
22 airflow pneumotometer as provided by Paradigm
23 Medical Industries) or can use a solid state
24 transducer (for example as supplied by Smart Lens
25 DCT) together with suitable telemetry system to
26 process the detected data. The arterial function
27 has been found to have a significant dynamic range
28 of approximately 0-12 Hz, and thus, the choice of a
29 pneumatic versus a solid state transducer system
30 will depend on a suitable dynamic range being
31 provided by the particular tonometer device used. A
32 probe 15 is applanated on the cornea 23 to record

1 intraocular pressure. The tonometer device 13
2 samples at 200 Hz with a resolution of 0.01 mmHg and
3 the signals are acquired over a 20 second period.
4 Pulsatile variation of intraocular pressure results
5 from pressure oscillations generated by cardiac
6 contraction altering the distending pressure in the
7 vessel walls. Compliance of an artery, or an entire
8 arterial bed, describes the ability to store a
9 varying amount of blood. Changes in volume within
10 the ocular vascular bed will produce an equal change
11 in volume. The pulsatile ocular waveforms are
12 recorded after administration of oxybuprocaine 0.4%
13 drops to anaesthetise the cornea.

14

15 The variation in intra-ocular pressure as a function
16 of time reflects the introduction of the bolus of
17 blood 7 into the ocular vascular network 9. The
18 ocular vascular network 9 expands to accommodate the
19 additional volume of blood.

20

21 As the intra-ocular fluids are incompressible, the
22 intra-ocular pressure response to the volume change
23 will depend of the viscoelastic properties of the
24 vessel network and the ocular rigidity. The
25 mechanical properties and distending pressures will
26 vary at different sites in the ocular vascular
27 network 9 and it is the composite effect of these
28 influences that determine the intra-ocular pressure
29 waveform morphology. Whilst the rigidity of the
30 ocular coat can vary between individuals, the half-
31 life of the collagen and elastin components are
32 measured in years. Consequently, the characteristics

1 of these boundary structures would not be expected
2 to change significantly within an individual over a
3 period of weeks or months. Therefore changes
4 recorded in the intra-ocular pressure pulse waveform
5 will be reflective of alteration in the viscoelastic
6 properties of the ocular microcirculatory bed.

7
8 The present invention uses the directly recorded
9 change in intra-ocular pressure in its analysis and
10 not the generated flow output measurements from the
11 device that relate pressure change to volume change
12 within the eye. The pulsatility of the intra-ocular
13 pressure is dependent on the pulsatile inflow and
14 distension of the vessels which is related to the
15 viscoelastic properties of the ocular circulation.
16 Scleral rigidity may limit the frequency of pressure
17 fluctuations but does not cause variation in
18 pressure.

19
20 In the example shown in Fig. 2, a colour doppler
21 ultrasound imager 17 is used to examine the blood
22 velocity waveform in the retrobulbar ocular
23 circulation. The ultrasound imager may suitably be
24 a Phillips ATL HDI3500 Ultrasound Machine.

25
26 The appropriate blood vessels then have to be
27 located and identified. One way of doing this is to
28 employ simultaneous B-scan and doppler imaging.
29 However, there are a number of practical
30 difficulties that have to be overcome when
31 performing this. Firstly, the orbit is three
32 dimensional but viewing is possible only in two

1 dimensions using the ultrasound machine.
2 Furthermore, the ophthalmic artery is tortuous and
3 has many branches and so it is difficult to get
4 clear views and for the operator to know exactly
5 where he is looking. There are also wide anatomical
6 variations in the position and branching nature of
7 the ophthalmic artery between individuals.

8
9 These problems have been addressed by recording
10 real-time colour motion pictures when initially
11 inspecting the artery in a subject. They are then
12 played back under 'cineloop review' and, in
13 conjunction with depth measurements, used to
14 orientated the operator back to the original
15 recording site. Pre-recorded velocity waveforms
16 finally verify dimensional and morphological
17 authenticity of waveforms under view.

18
19 The beam from the ultrasound imager can be focussed
20 using an appropriate software algorithm.

21
22 The sample volume defined by the imager 17 is placed
23 over a vessel of interest, in this case, the bolus
24 of blood 7 and the frequency shifts received are
25 assembled into a spectral waveform. The spectral
26 waveform represents the cumulative frequency shifts
27 present and can be displayed as a time-velocity
28 waveform.

29
30 In use, alternate measurements of the arterial pulse
31 waveform and blood velocity profile are taken.

1 The shape of the linear velocity flow waveform,
2 recorded in the retrobulbar circulation , is
3 determined by and is critically dependent on changes
4 in total cross-sectional area of the ocular vascular
5 network.

6
7 Like pressure, flow will also vary at different
8 sites in the ocular vascular network 9 and the
9 velocity waveform morphology therefore reflects the
10 status of the entire ocular vascular network 9. In
11 essence, the flow velocity waveform derived from the
12 retrobulbar circulation and the intra-ocular
13 pressure waveform reflect the sum total of the
14 various calibre and pressure changes throughout the
15 ocular vascular bed.

16
17 Measured over time, changes in the linear flow
18 waveform can provide information on changes in the
19 ability of the ocular vascular network to expand
20 during the cardiac cycle. Such information can lead
21 to early diagnosis and subsequent early treatment of
22 disease.

23
24 The present invention uses linear velocity of flow
25 in calculating the vascular impedance of the
26 microcirculation as changes in velocity of flow are
27 determined by changes in the total cross-sectional
28 area of the ocular vascular network 9. Furthermore,
29 the use of linear velocity of flow permits
30 comparisons of impedance moduli derived from
31 different arteries and in the same artery under

1 varying conditions. This comparison cannot be
2 validly made using volume flow measurements.

3

4 Previous work to characterise the arterial system
5 has been based on the relationship between pressure
6 and flow recorded at the same position in time and
7 space. Windkessel analysis is used to apply an
8 electrical circuit analogy of input impedance to fit
9 components of total compliance and total resistance
10 to the distal arterial tree. However, this
11 technique does not provide unique solutions.

12

13 In contrast to previous work, the present invention
14 provides for the recording of pressure and velocity
15 waveforms at different positions on the arterial
16 tree. In the ocular microcirculation, ophthalmic
17 flow can be considered giving rise to the
18 intraocular pressure. This means that an analogy
19 can be drawn with two port analysis of electrical
20 circuit design, which relates an input signal to an
21 output signal. The relationship between the
22 intraocular pressure and the corresponding
23 ophthalmic velocity waveform can thus be
24 characterised.

25

26 The waveforms of pressure and velocity have a
27 certain periodicity according to the heart rate of
28 the subject being tested. However, the breathing of
29 the subject also affects the waveforms. Hence, a
30 measure of compliance can be made that takes into
31 account the respiratory variations. This overcomes
32 an assumption made by use of a normal Windkessel

1 analysis, namely that the pressure flow waveform has
2 an infinite pulse wave velocity. This measure of
3 compliance that takes the respiratory variations
4 into account can be known as the apparent
5 compliance. It can be used in conjunction with the
6 two port model to characterise the system.

7

8 Typical examples of intraocular pressure and
9 velocity profiles (obtained from the ophthalmic
10 artery) are shown in Figures 3 and 4.

11

12 Fig. 3 is a graph of pressure plotted with respect
13 to time. The figure shows the periodicity of the
14 pressure fluctuation. The cardiac cycle can be
15 identified from the period of the pressure
16 fluctuation as being approximately 0.9 s.

17

18 Fig.4 is a graph of linear blood velocity plotted
19 with respect to time. The figure shows the
20 periodicity of linear velocity fluctuation. The
21 cardiac cycle can be identified from the period of
22 the linear velocity fluctuation as being
23 approximately 0.9s.

24

25 The sites of data acquisition enable the recording
26 of pressure and linear velocity waveforms that
27 provide information about the entire ocular vascular
28 network and not merely single vessel in the network.
29 Measurements are obtained sequentially using the
30 tangent method to align pressure and velocity
31 waveforms. This technique is employed to ensure
32 effective alignment of waveforms for analysis. The

1 signals may also be gated to an ECG. Other known
2 methods may also be employed.

3

4 As seen in Figures 3 and 4, the velocity and
5 pressure signals are periodic and time dependent and
6 can thus be represented in the frequency domain by
7 obtaining their Fourier transform: $P(\omega) = FT [P(t)]$
8 and $V(\omega) = FT[V(t)]$ where FT represents Fourier
9 transformation. In addition, each frequency
10 component of pressure and velocity will have its own
11 associated phase (ϕ_p pressure phase, ϕ_v velocity
12 phase). The frequency dependent impedance modulus
13 and phase can be determined from: $Z(\omega) = P(\omega)/V(\omega)$
14 and $\phi(\omega) = \phi_p(\omega) - \phi_v(\omega)$.

15

16 Figures 5 and 6 show typical plots of $Z(\omega)$ and $\phi(\omega)$
17 for a normal subject.

18

19 The flow and first derivative of pressure occur at
20 similar time points. As pressure and flow are
21 obtained sequentially the first derivative of the
22 pressure waveform is aligned to the flow waveform.
23 A tangent to end diastole and a tangent to the
24 initial upstroke in pressure wall intersect at the
25 "foot" of the waveform. This point is aligned with
26 the same point on the flow waveform.

27

28 An improved alignment can be obtained by syncing
29 the peak velocity detected by the imager 17 to an
30 ECG device.

31

1 Frequency domain analysis provides information about
2 steady-state (resistance) and pulsatile function
3 (characteristic impedance) of the ocular
4 circulation. In Fig. 5, the steady state resistance
5 is shown in area A and the characteristic impedance
6 in area B. These signals are stored in digital form
7 and the digitised signals are amenable to analysis
8 in the time domain with the application of
9 mathematical models to interpret waveshape changes
10 in relation to the mechanical properties of the
11 ocular circulatory bed.

12

13 The present invention is highly advantageous with
14 respect to the prior art because it provides a non-
15 invasive method and apparatus for measuring vascular
16 impedance and in particular, through interrogation
17 of the wave shape, of the linear velocity profile of
18 the blood bolus in the retrobulbar circulation.
19 Previously, invasive techniques had only been
20 thought capable of providing information on the
21 linear velocity profile. Such techniques are
22 expensive and cannot be used to obtain repeat
23 results over a period of time for the same subject.
24 The present invention therefore allows a physician
25 to monitor changes in the microcirculation of the
26 eye and to extrapolate the data to make clinical
27 judgements in various disease states associated with
28 an increase in cardiovascular events.

29

30 The present invention is applicable in a number of
31 areas of clinical research. Some examples are given
32 below.

1
2 It has been recognised for many years that
3 characteristic changes in the arterial pressure
4 pulse contour occur in many disease states and with
5 physiological and pharmacological interventions.
6 Alteration in arterial waveform morphology typically
7 involves a steepening of the diastolic decay and a
8 diminution in the amplitude and duration of the
9 oscillatory waveform that distorts the proximal part
10 of diastole from a pure monoexponential. The
11 oscillatory diastolic waveform arises from wave
12 reflection and damped resonance occurring in the
13 arterial tree with the major sites of reflected
14 waves originating in smaller arteries and
15 arterioles. Loss of the oscillatory diastolic
16 waveform is recognised as an early marker of altered
17 vessel wall properties that identifies impaired
18 pulsatile function of arteries as it can be found in
19 patients at increased cardiovascular risk without
20 alteration in total peripheral resistance. This has
21 been demonstrated in patients with diabetes mellitus
22 and cigarette smokers. Whilst the microvascular
23 changes associated with diabetes are well
24 recognised, the structural changes that are commonly
25 found in the arterioles of smokers and rarely in
26 non-smokers, are less well appreciated. These
27 microvascular abnormalities may account for the
28 common occurrence of microinfarcts found in
29 association with diabetes and cigarette smoking that
30 have hitherto gone unrecognised.
31

1 Analysis of the arterial pressure pulse waveform can
2 also be useful in identifying the haemodynamic
3 action of drug therapy not detected by the
4 traditional measurement of peripheral resistance.

5

6 Improvements and modifications may be incorporated herein
7 without deviating from the scope of the invention.

1 CLAIMS

2

3 1. Apparatus for the measurement of vascular
4 impedance of the ocular micro circulation *in vivo*,
5 comprising intra-ocular pressure measurement means
6 from which a pressure pulse waveform is calculable,
7 blood velocity profile measurement means for
8 measuring the linear blood flow velocity in the
9 retrobulbar circulation, and means for calculating a
10 vascular impedance modulus from the pressure pulse
11 waveform and the linear blood flow velocity.

12

13 2. Apparatus as claimed in claim 1, wherein the
14 intra-ocular pressure measurement means is suitable
15 for measuring the maximum and minimum pressure
16 values of the pulse profile to calculate a mean
17 intra-ocular pressure.

18

19 3. Apparatus as claimed in claim 1 or claim 2,
20 suitable for measuring how the pressure pulse
21 waveform and the linear blood flow velocity vary
22 over the period of a respiratory cycle.

23

24 4. Apparatus as claimed in any preceding claim,
25 wherein a solid state transducer is used to measure
26 intra-ocular pressure.

27

28 5. Apparatus as claimed in claim 4, wherein a
29 suitable solid state transducer operates in
30 conjunction with a suitable telemetry system to
31 process the data.

32

1 6. Apparatus as claimed in any of claims 1 to 3,
2 wherein an ocular pneumotonometer is used to measure
3 intra-ocular pressure.

4

5 7. Apparatus as claimed in any preceding claim,
6 wherein the blood velocity profile measurement means
7 is an ultrasound device.

8

9 8. Apparatus as claimed in claim 7, wherein the
10 ultrasound device is a doppler ultrasound imager.

11

12 9. Apparatus as claimed in any preceding claim
13 further comprising motion picture generation means
14 to produce moving images of an artery.

15

16 10. Apparatus as claimed in claim 9, wherein the
17 moving images are capable of being used to ensure
18 that a user of the apparatus can accurately identify
19 the location of an artery.

20

21 11. Apparatus as claimed in any preceding claim,
22 wherein the change in the pulsatile intra-ocular
23 pressure waveform and the linear blood flow velocity
24 are measured sequentially.

25

26 12. Apparatus as claimed in any preceding claim,
27 wherein the means for calculating the vascular
28 impedance modulus comprises means for;

29 obtaining the fourier transform of the intra-
30 ocular pressure pulse waveform and the linear blood
31 flow velocity and dividing the transformed values of
32 the pulsatile change in the intra-ocular pressure

1 pulse by the transformed retrobulbar blood flow
2 velocity.

3

4 13. Apparatus as claimed in any preceding claim,
5 wherein the pulsatile change in intra-ocular
6 pressure has a phase associated therewith.

7

8 14. Apparatus as claimed in any preceding claim,
9 wherein the intra-ocular blood velocity has a phase
10 associated therewith.

11

12 15. A method for the measurement of vascular
13 impedance of the ocular micro circulation in vivo,
14 comprising the steps of: measuring the intra-ocular
15 pressure pulse waveform of the ocular network;
16 measuring the linear blood flow velocity in the
17 retrobulbar circulation; and
18 calculating the vascular impedance modulus from the
19 intra ocular pressure pulse waveform and the linear
20 blood flow velocity waveform.

21

22 16. A method as claimed in claim 15, wherein the
23 pressure pulse waveform and the linear blood flow
24 velocity are measured over the period of a
25 respiratory cycle, and their variation therewith is
26 measured.

27

28 17. A method as claimed in claim 16, wherein the
29 variations are used in the calculation of the
30 vascular impedance modulus.

31

1 18. A method as claimed in any of claims 15 to 17,
2 further comprising the steps of recording moving
3 images of an artery.

4

5 19. A method as claimed in claim 18, wherein the
6 moving images are used to accurately identify the
7 location of an artery.

8

9 20. A method as claimed in any of claims 15 to 19,
10 wherein the change in the pulsatile intra-ocular
11 pressure waveform and the linear blood flow velocity
12 are measured sequentially.

13

14 21. A method as claimed in any of claims 15 to 20,
15 wherein the step of calculating the vascular
16 impedance modulus comprises the steps of;
17 obtaining the fourier transform of the intra-ocular
18 pressure pulse waveform and the linear blood flow
19 velocity and dividing the transformed values of the
20 pulsatile change in the intra-ocular pressure pulse
21 by the transformed retrobulbar blood flow velocity.

22

1 / 3

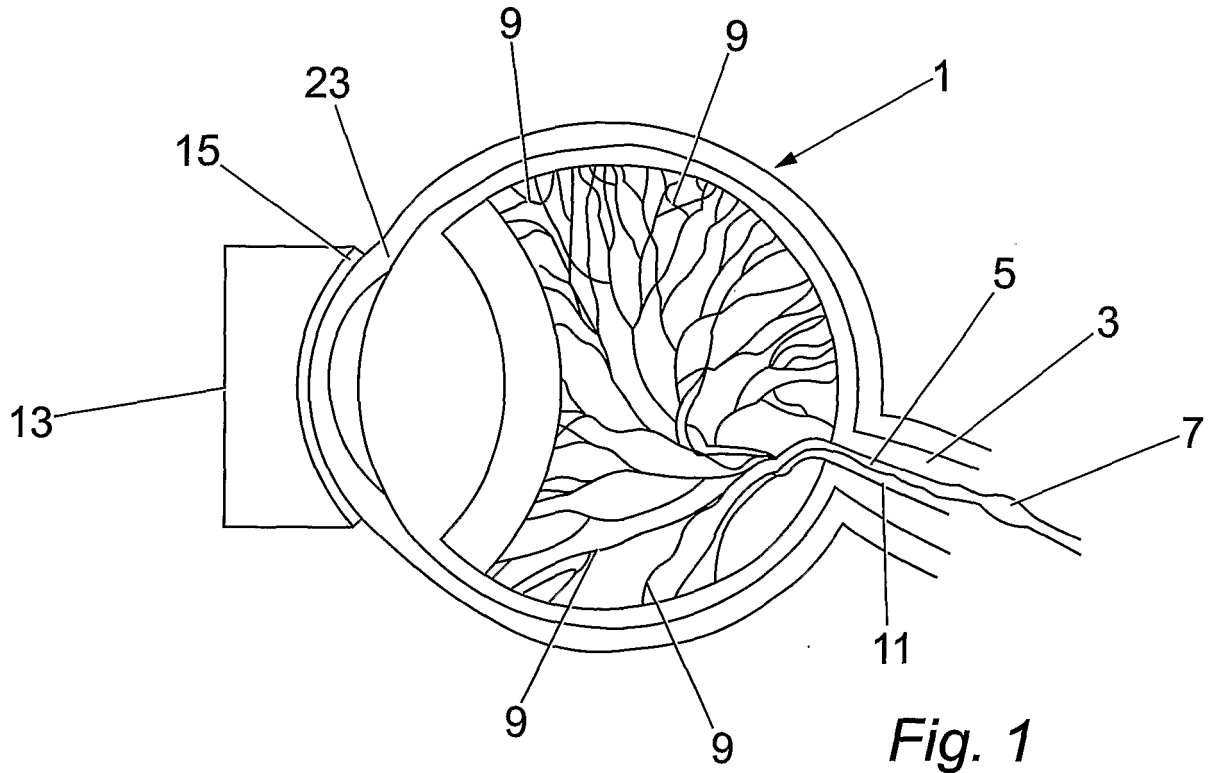

Fig. 1

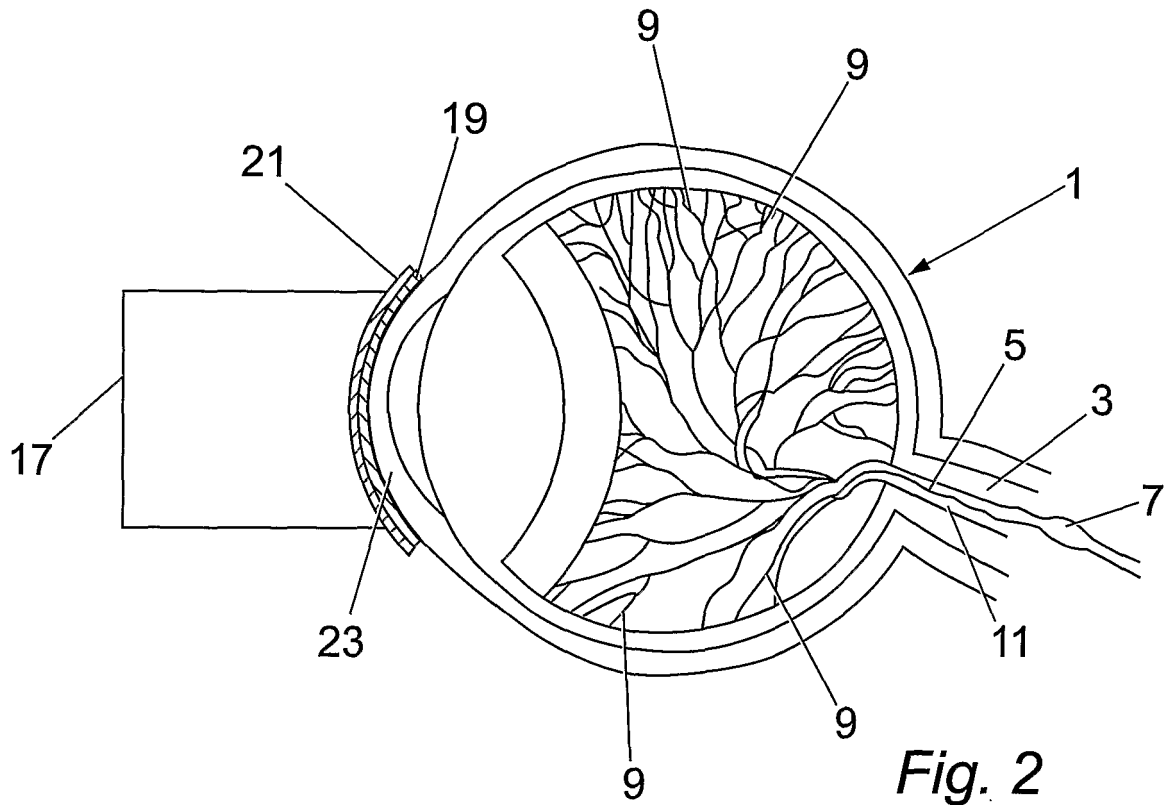

Fig. 2

2 / 3

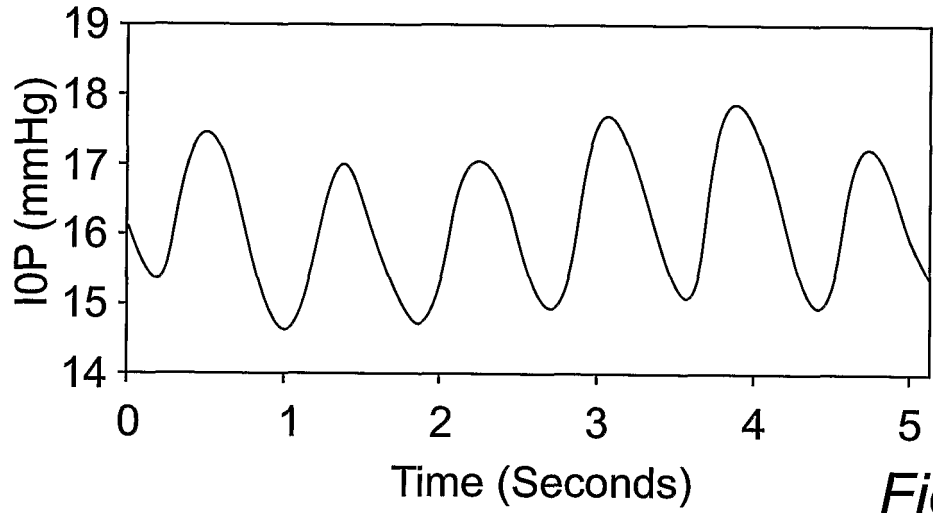

Fig. 3

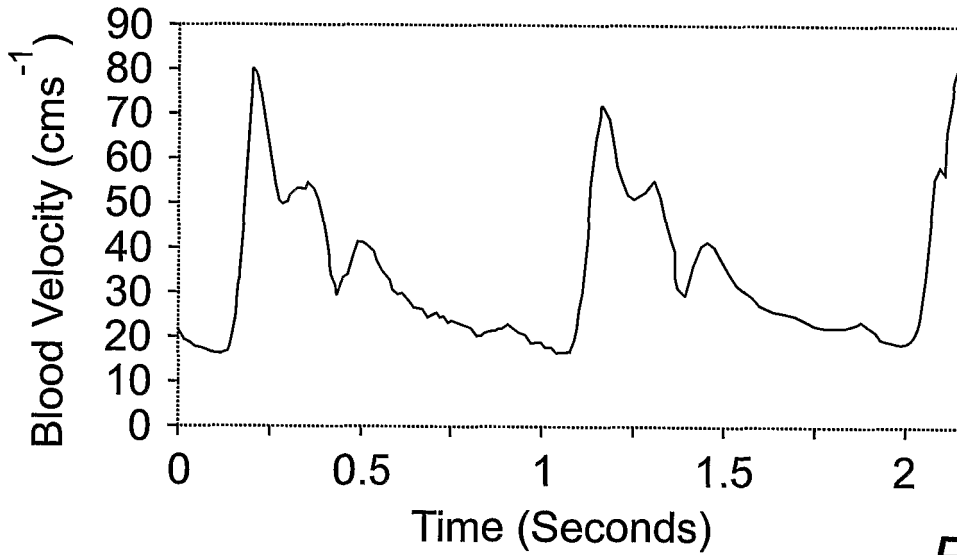

Fig. 4

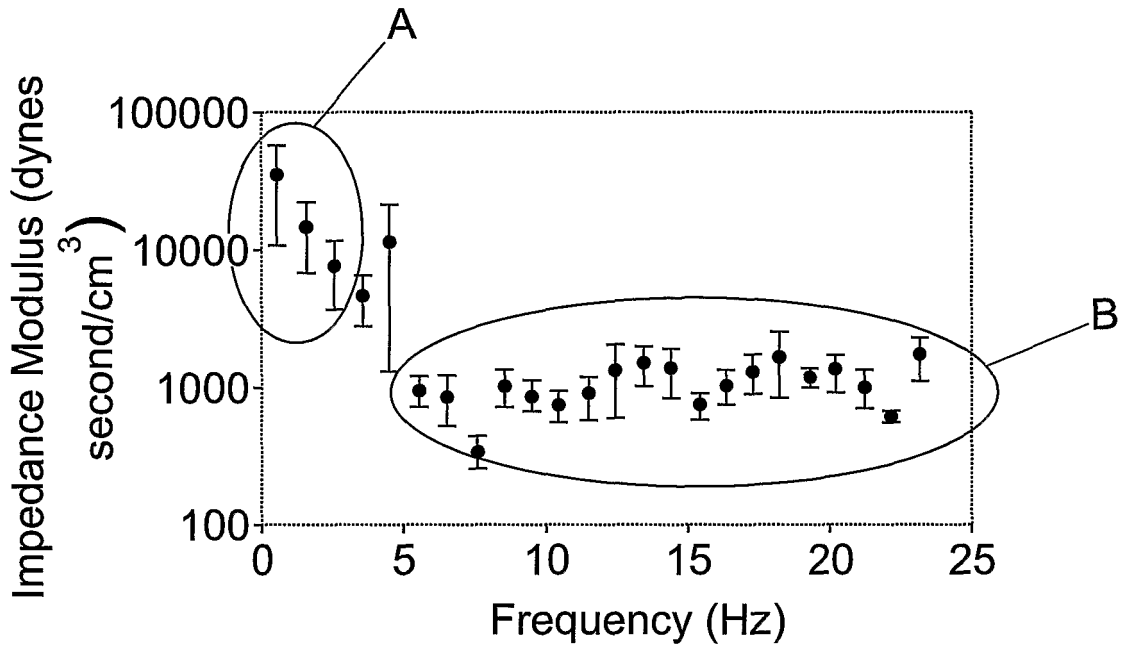

Fig. 5

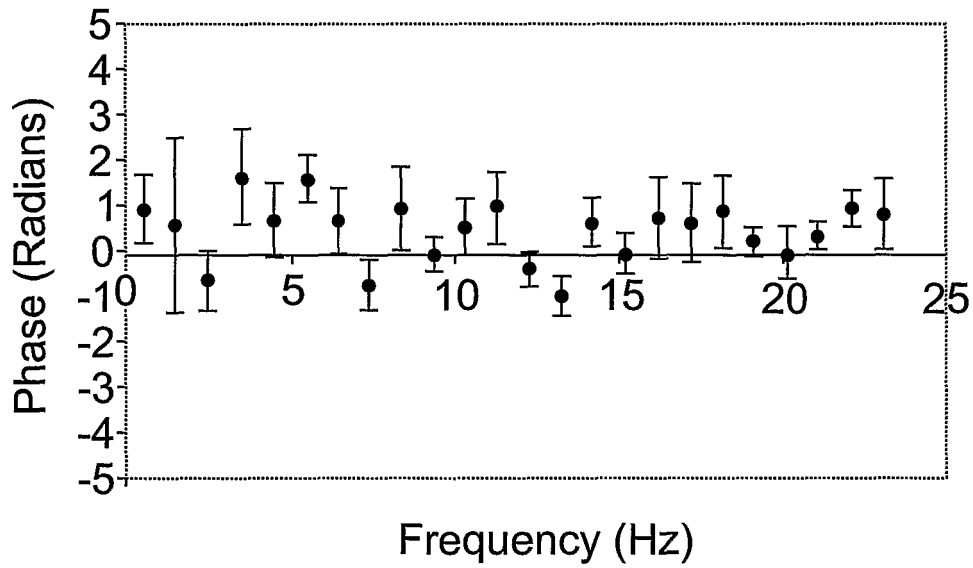

Fig. 6

专利名称(译)	血管阻抗测量装置		
公开(公告)号	EP1496793A2	公开(公告)日	2005-01-19
申请号	EP2003720724	申请日	2003-04-22
[标]申请(专利权)人(译)	贝尔法斯特女王大学		
申请(专利权)人(译)	贝尔法斯特女王大学		
当前申请(专利权)人(译)	贝尔法斯特女王大学		
[标]发明人	MCVEIGH GARY EUGENE		
发明人	MCVEIGH, GARY, EUGENE		
IPC分类号	A61B3/12 A61B3/16 A61B5/00 A61B5/0285 A61B8/06 A61B8/10		
CPC分类号	A61B5/02007 A61B3/16 A61B8/06 A61B8/13		
代理机构(译)	COOPER , JOHN		
优先权	2002008945 2002-04-19 GB		
其他公开文献	EP1496793B1		
外部链接	Espacenet		

摘要(译)

提供了用于测量体内眼循环的血管阻抗的装置和方法。从眼压的测量记录压力脉冲波形，并记录眼球后循环中血流的速度分布。这两个读数用于计算血管阻抗模量。