



(11) **EP 3 583 890 A3**

(12) **EUROPEAN PATENT APPLICATION**

(88) Date of publication A3:
04.03.2020 Bulletin 2020/10

(51) Int Cl.:
A61B 5/0205 (2006.01) **A61B 90/00** (2016.01)
A61M 25/01 (2006.01) **G01L 19/14** (2006.01)
A61B 5/0215 (2006.01) **A61B 5/06** (2006.01)
A61B 5/00 (2006.01) **A61B 17/00** (2006.01)
A61B 34/20 (2016.01) **A61B 90/30** (2016.01)
A61M 25/09 (2006.01)

(43) Date of publication A2:
25.12.2019 Bulletin 2019/52

(21) Application number: **19181528.1**

(22) Date of filing: **20.06.2019**

(84) Designated Contracting States:
AL AT BE BG CH CY CZ DE DK EE ES FI FR GB GR HR HU IE IS IT LI LT LU LV MC MK MT NL NO PL PT RO RS SE SI SK SM TR
Designated Extension States:
BA ME
Designated Validation States:
KH MA MD TN

(72) Inventors:
• **GLEICH, Bernhard**
5656 AE Eindhoven (NL)
• **RAHMER, Jürgen Erwin**
5656 AE Eindhoven (NL)

(30) Priority: **20.06.2018 EP 18178783**

(74) Representative: **de Haan, Poul Erik et al**
Philips International B.V.
Philips Intellectual Property & Standards
High Tech Campus 5
5656 AE Eindhoven (NL)

(71) Applicant: **Koninklijke Philips N.V.**
5656 AE Eindhoven (NL)

(54) **MAGNETIC MEASUREMENT DEVICE**

(57) The invention relates to a measurement device 1 comprising a rotatable magnetic object 4 which can oscillate with a resonant frequency if excited by an external magnetic torque. The measurement device 1 is adapted such that the resonant frequency depends on the temperature or on another physical or chemical quantity like pressure, in order to allow for a wireless temperature measurement or measurement of the other physical or chemical quantity via an external magnetic field providing the external magnetic torque. This measurement device can be relatively small, can be read-out over a relatively larger distance and allows for a very accurate measurement.

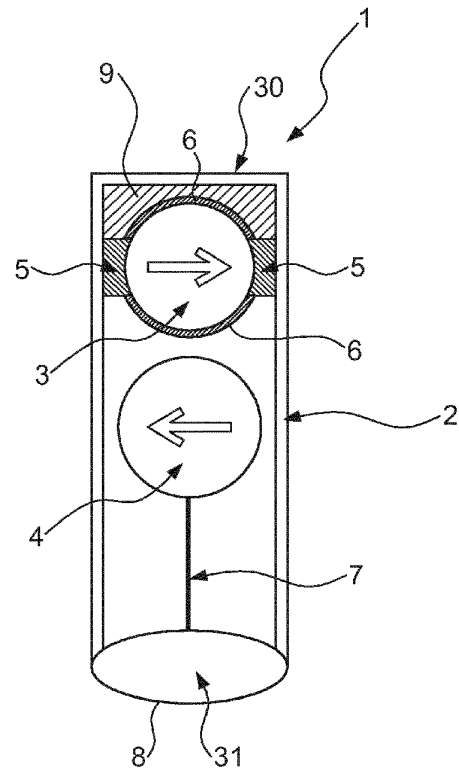

FIG. 1

EP 3 583 890 A3



PARTIAL EUROPEAN SEARCH REPORT

Application Number

under Rule 62a and/or 63 of the European Patent Convention.
This report shall be considered, for the purposes of subsequent proceedings, as the European search report

EP 19 18 1528

5

10

15

20

25

30

35

40

45

50

55

DOCUMENTS CONSIDERED TO BE RELEVANT			
Category	Citation of document with indication, where appropriate, of relevant passages	Relevant to claim	CLASSIFICATION OF THE APPLICATION (IPC)
X A	US 2007/236213 A1 (PADEN BRADLEY E [US] ET AL) 11 October 2007 (2007-10-11) * paragraphs [0022], [0089] * * paragraph [0097] - paragraph [0103] * * paragraph [0128] - paragraph [0130] * * paragraph [0137] - paragraph [0145] * * paragraph [0106] - paragraph [0107] * * figures 1a-c, 4a-10b, 13-14b, 22-18 *	1-3, 8, 13-15 4-7, 9-11	INV. A61B5/0205 A61B90/00 A61M25/01 G01L19/14
X	US 2015/126829 A1 (BERNSTEIN JONATHAN J [US]) 7 May 2015 (2015-05-07) * paragraph [0017] - paragraph [0032] * * figures 1-3 *	1-3, 8, 12-15	ADD. A61B5/0215 A61B5/06 A61B5/00 A61B17/00 A61B34/20 A61B90/30 A61M25/09
X	US 4 345 482 A (ADOLFSSON MORGAN ET AL) 24 August 1982 (1982-08-24) * column 4, line 17 - line 24 * * figures 4a-b *	1, 2	
			TECHNICAL FIELDS SEARCHED (IPC)
			A61B G01L G01K
INCOMPLETE SEARCH			
The Search Division considers that the present application, or one or more of its claims, does/do not comply with the EPC so that only a partial search (R.62a, 63) has been carried out.			
Claims searched completely :			
Claims searched incompletely :			
Claims not searched :			
Reason for the limitation of the search: see sheet C			
Place of search		Date of completion of the search	Examiner
The Hague		23 January 2020	Görlach, Tobias
CATEGORY OF CITED DOCUMENTS			
X : particularly relevant if taken alone Y : particularly relevant if combined with another document of the same category A : technological background O : non-written disclosure P : intermediate document		T : theory or principle underlying the invention E : earlier patent document, but published on, or after the filing date D : document cited in the application L : document cited for other reasons & : member of the same patent family, corresponding document	

EPO FORM 1503 03.82 (P04E07)

**INCOMPLETE SEARCH
SHEET C**Application Number
EP 19 18 1528

5

Claim(s) searched incompletely:
1-15

10

Reason for the limitation of the search:

1 The present application does not meet the requirements of Article 83 EPC, because the disclosure of the present application is not sufficient to carry out the invention as defined by the claims over the whole range claimed.

15

1.1 Claim 1 relates to a measurement device using rotational oscillations of a magnetic object whose resonance frequency depends (a) on temperature or (b) "on the other physical or chemical quantity". While alternative (a) is not considered to be problematic, alternative (b) covers an wide variety of different quantities. However, the description of the present application mostly discusses pressure as the physical quantity, with a brief reference to detecting the presence of an organic solvent (page 17, lines 18-22). Prior to this passage, a brief remark that other quantities may be measured is given (page 17, lines 11-17); however, due to the wide variety of potential quantities to be measured, finding out how each of these possible quantities may (or may not, leading to non-working embodiments) affect the resonance frequency would mean an undue burden for a person skilled in the art, also because the quantity in question may change the resonance frequency by altering the magnetic field at or the magnetic moment of the magnetic object (claim 3), or by changing the distance between two magnetic objects (claim 7), adding to the complexity of the task of finding a (potential) effect on the resonance frequency. It appears that the assumption of a change in resonance frequency for any physical or chemical quantity is largely speculative and far broader than justified by the disclosure of the present application.

20

25

30

1.2 Since the subject-matter of dependent claims 2-12 (claim 12 being a hybrid claim) comprises the subject-matter of claim 1, and since none of these claims clearly limits the subject-matter of claim 1 to a particular quantity being measured, this objection also applies to claims 2-12. While claims 4, 6 and 8 relate to a temperature dependence of the magnetic material, this does not necessarily imply that temperature is to be measured, it could also serve for compensation of temperature effects, which is claimed for alternative (b).

35

1.3 Since the other independent claims (i.e. claims 13-15) directly or indirectly relate to measuring "the other physical or chemical quantity", this objection also applies, mutatis mutandis, to claims 13-15.

40

45

1.4 Therefore, the disclosure of the present application is only considered to be sufficient for the particular cases of the physical quantity being temperature or pressure, and for the chemical quantity being the presence of an organic solvent. For these particular cases, a meaningful search can be carried out (see Guidelines F-III, 1, last paragraph).

50

55

**ANNEX TO THE EUROPEAN SEARCH REPORT
ON EUROPEAN PATENT APPLICATION NO.**

EP 19 18 1528

5 This annex lists the patent family members relating to the patent documents cited in the above-mentioned European search report.
The members are as contained in the European Patent Office EDP file on
The European Patent Office is in no way liable for these particulars which are merely given for the purpose of information.

23-01-2020

Patent document cited in search report	Publication date	Patent family member(s)	Publication date
US 2007236213 A1	11-10-2007	AU 2007319761 A1 EP 1998664 A2 JP 2009532113 A US 2007236213 A1 US 2009099442 A1 WO 2008060649 A2	22-05-2008 10-12-2008 10-09-2009 11-10-2007 16-04-2009 22-05-2008
US 2015126829 A1	07-05-2015	NONE	
US 4345482 A	24-08-1982	DE 2945019 A1 SE 414672 B US 4345482 A	29-05-1980 11-08-1980 24-08-1982

EPO FORM P0459

For more details about this annex : see Official Journal of the European Patent Office, No. 12/82

专利名称(译)	电磁测量仪		
公开(公告)号	EP3583890A3	公开(公告)日	2020-03-04
申请号	EP2019181528	申请日	2019-06-20
[标]申请(专利权)人(译)	皇家飞利浦电子股份有限公司		
申请(专利权)人(译)	皇家飞利浦N.V.		
当前申请(专利权)人(译)	皇家飞利浦N.V.		
[标]发明人	GLEICH BERNHARD RAHMER JURGEN ERWIN		
发明人	GLEICH, BERNHARD RAHMER, JÜRGEN ERWIN		
IPC分类号	A61B5/0205 A61B90/00 A61M25/01 G01L19/14 A61B5/0215 A61B5/06 A61B5/00 A61B17/00 A61B34/20 A61B90/30 A61M25/09		
CPC分类号	A61B5/02055 A61B5/0215 A61B5/062 A61B5/6851 A61B5/6852 A61B90/39 A61B2017/00809 A61B2034/2051 A61B2090/309 A61B2090/376 A61B2090/3937 A61B2090/3954 A61B2090/3966 A61B2090/3995 A61B2560/0252 A61B2562/0223 A61M25/0127 A61M25/09041 A61M2025/0166 A61B34/20 G01L19/14 G01L1/10		
代理机构(译)	德哈恩波尔ERIK		
优先权	2018178783 2018-06-20 EP		
其他公开文献	EP3583890A2		
外部链接	Espacenet		

摘要(译)

测量装置技术领域本发明涉及一种测量装置1，其包括可旋转的磁性物体4，如果被外部磁转矩激励，该磁性物体可以以共振频率振荡。测量设备1适于使得谐振频率取决于温度或取决于诸如压力的另一物理或化学量，以便允许无线温度测量或经由提供磁场的外部磁场来测量另一物理或化学量。外部磁转矩。该测量装置可以相对较小，可以在相对较大的距离上读出，并且可以进行非常精确的测量。

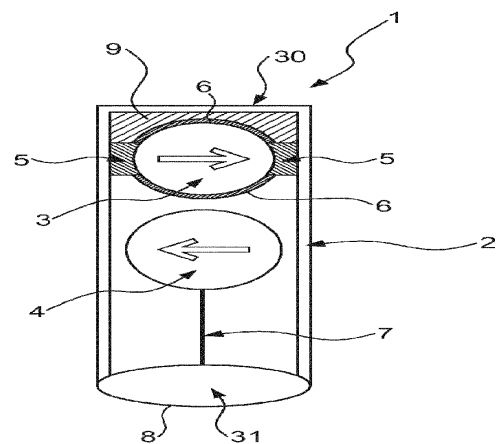

FIG. 1