



(12) **EUROPEAN PATENT APPLICATION**

(43) Date of publication:
27.01.2016 Bulletin 2016/04

(51) Int Cl.:
G08B 21/00 (2006.01) A61B 5/00 (2006.01)

(21) Application number: **15177627.5**

(22) Date of filing: **21.07.2015**

(84) Designated Contracting States:
AL AT BE BG CH CY CZ DE DK EE ES FI FR GB GR HR HU IE IS IT LI LT LU LV MC MK MT NL NO PL PT RO RS SE SI SK SM TR
 Designated Extension States:
BA ME
 Designated Validation States:
MA

(72) Inventors:
 • **CAMPO, David**
92100 BOULOGNE BILLANCOURT (FR)
 • **CARPENTIER, Stéphane**
Tseung Kwan O (CN)
 • **DUMOULIN, Amaury**
92200 NEUILLY SUR SEINE (FR)
 • **BUARD, Nadine**
92190 MEUDON (FR)
 • **CARREEL, Eric**
92190 MEUDON (FR)

(30) Priority: **21.07.2014 FR 1456996**

(71) Applicant: **Withings**
92130 Issy les Moulineaux (FR)

(74) Representative: **Cabinet Plasseraud**
52, rue de la Victoire
75440 Paris Cedex 09 (FR)

(54) **MONITORING DEVICE WITH VOLATILE ORGANIC COMPOUNDS SENSOR AND SYSTEM USING SAME**

(57) Video monitoring device (1) comprising a computing unit (4), a camera (2), a communication interface (42), and a volatile organic compounds sensor (37) configured to measure at least a concentration of organic compounds in a room of interest, said computing unit being configured to record the concentrations of organic

compounds reported by the volatile organic compounds sensor, and configured to send images taken by the camera and volatile organic compounds concentrations to a remote entity, such as a smartphone (22) over a wireless link.

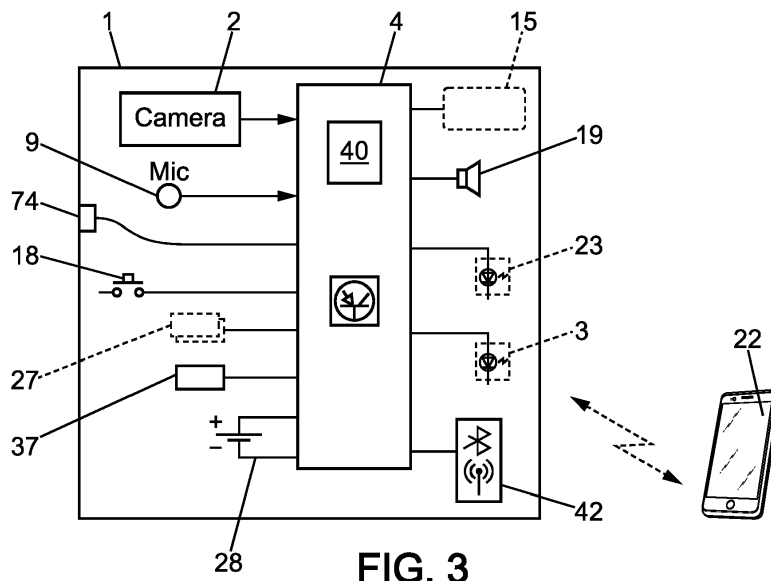

FIG. 3

Description

[0001] The present invention relates to video monitoring devices and methods. For example, such video monitoring devices and methods can be used to monitor a baby sleeping in its crib, with optionally an interaction between the baby and its parent or caregiver, either an audio interaction or a video/audio interaction

[0002] More specifically, it is known in the art a method and device for monitoring certain vital signs of the baby, in particular the heart rate and respiratory rate.

[0003] US8094013 and WO2013170035 disclose devices of this type.

[0004] However, the need to improve such known devices and more generally to improve general purpose indoor video monitoring devices/systems has been identified by the inventors.

[0005] The present invention is intended to overcome at least some of the disadvantages of the prior art.

[0006] To this end, it is proposed a video monitoring device comprising a computing unit, a camera, a communication interface, and a volatile organic compounds sensor configured to measure at least a concentration of organic compounds in a room of interest, said computing unit being configured to record the concentrations of organic compounds reported by the volatile organic compounds sensor, and configured to send images taken by the camera and volatile organic compounds concentrations to a remote entity, such as a smartphone over a wireless link.

[0007] With these arrangements, video surveillance can be advantageously complemented by remote surveillance of air quality in a room. Also, images and VOC levels can be analyzed in correlation.

It is noted that volatile organic compounds is called in short 'VOC'.

[0008] In various embodiments of the above invention, one or more of the following arrangements may possibly be used.

- the volatile organic compounds sensor (37) is configured to detect multiple organic gases, such as butane, propane, octane, methanol, ethanol, propanol, butanol, and even aromatic compounds such as benzene, ethylbenzene, and toluene; most usual gases that are nocive or at least not particularly healthy to breathe, that may be present in a room of a home, can be detected;
- the volatile organic compounds sensor is configured to detect H₂S; this allows detection of something with is decomposing or rotting in the room;
- the volatile organic compounds sensor can be complemented by a humidity sensor to compensate for water vapour in air; improving accuracy;
- the computing unit can store successive organic compound concentration level values in memory, for transmission at regular intervals to the remote entity; this decreases the load on wireless network;

- an alert threshold can be provided in the computing unit, which allows to send immediately to the smartphone an alert message, as soon as the VOC concentration exceeds the predetermined alert threshold;
 - the VOC sensor can be an ion detector using photoionization of the molecules in an air sample collected in the room of interest;
 - the VOC sensor can be an electrochemical MOS on-chip sensor using oxydation-reduction reactions with gas(es) present in ambient air, to assess VOC concentration level; this facilitates integration of the sensor in the device;
 - the VOC sensor provides an aggregate level of organic compounds which combines all the organic compounds present in the air of the room.
 - Some vital signs of a baby, such as the heart rate (HR) and/or respiratory rate (RR) of the baby are evaluated by photoplethysmographic analysis of the captured images, thereby the video monitoring device forms a device suitable for monitoring a baby in a room or in a crib; a correlation between on one hand VOC levels and on the other hand heart rate (HR) and/or respiratory rate (RR) can be assessed;
- R8 The video monitoring device may comprise a loudspeaker and a microphone, thereby forming two-way audio link, particularly suitable for interacting with a baby in a room or in a crib, remotely from a parent/caretaker using the smartphone

[0009] The invention also relates to a system comprising a monitoring device as described above and a smartphone.

[0010] The invention also relates to a method to monitor events in a room and an air quality in the room, the method comprising :

- measuring a concentration of organic compounds in a room with a volatile organic compounds sensor,
- taking images of at least part of the room,
- storing the organic compound concentration data in a memory of a computing unit,
- send images taken by the camera and volatile organic compounds concentrations, from the computing unit to a remote entity such as a smartphone over a wireless link.

[0011] In addition, optionally, the transmission to the smartphone may occur at regular intervals.

[0012] In addition, optionally an alert threshold may be provided in the computing unit, the method further comprising:

- sending quickly to the smartphone an alert message, as soon as the VOC concentration exceeds the predetermined alert threshold.

[0013] Other features, objects, and advantages of the

invention will be apparent from reading the following description of an embodiment of the invention, given by way of non-limiting example. The invention will also be better understood by referring to the accompanying drawings, in which:

- figure 1 is a general view of a crib containing a baby to be monitored by a method according to the invention,
- figure 2 is a view of the video monitoring device,
- figure 3 shows a schematic block diagram of the device of figure 2,
- figure 4 represents a sample image captured by the camera,
- figure 5 illustrates the construction of edge segments,
- figure 6 illustrates the selection of an ellipse and of the area of interest,
- figure 7 illustrates an example of a filtered signal,
- figure 8 shows a flowchart illustrating the method,
- figure 9 illustrates a variant of the monitoring device with a detection sheet.

[0014] In the various figures, the same references designate identical or similar elements.

[0015] Figure 1 shows a baby **B** lying in a crib **13**. In the context of the invention, baby is understood to mean an infant or child less than 10 years old. We are particularly interested in the case where the baby is placed in the crib for a nap or for the night. Typically, in this configuration, the general lighting in the room will be low or very low, referred to herein as dim or nocturnal conditions providing partial or total darkness.

[0016] In the example shown, a video monitoring system, denoted **10**, comprises a video monitoring device **1** to be discussed in detail below, a mounting foot **12**, and a mounting clamp **11**. In the example shown, the mounting clamp is attached to a side rail of the crib or more generally of the bed. Note that in the monitoring assembly, it could also be secured to the crosspiece at the head or the foot of the bed.

[0017] Alternatively, the monitoring assembly may also be located elsewhere in the room.

[0018] The video monitoring device **1** may be attached to a different support, to a wall, to a bed canopy, etc.

[0019] As illustrated in more detail in figure 2, the video monitoring device **1** comprises a video camera **2**, which has a wide viewing angle over a solid angle of at least 90° or more (110° or 135°) so that the camera can capture images of the entire relevant area of the crib or even the entire room of interest.

[0020] In addition, the monitoring device comprises light-emitting diodes **3** (LED) capable of emitting in the infrared band, thus forming a source of infrared light.

[0021] The video monitoring device **1** further comprises a computing unit **4** with a memory **40** as well as a battery **28** or alternatively a power supply unit connecting to the grid.

[0022] The video monitoring device **1** preferably also comprises a wireless communication interface **42** configured for exchanging data with a remote entity such as a smartphone **22**.

[0023] The video monitoring device **1** may further comprise a microphone **9** for capturing sound, and a sound generator in the form of a small speaker **19**.

[0024] In addition, there may be a light source **23** for dim atmospheric lighting whose intensity can be controlled by the monitoring device, an air quality sensor **37**, and auxiliary sensors **27** for example for sensing temperature and/or humidity and/or air quality.

[0025] The video monitoring device **1** may further comprise one or more buttons **18**, intended to be operated by a user (for example to configure the device, turn it on and turn it off) as well as a small display **15** for displaying states or parameters of the device (in which case the buttons **18** may be touch-sensitive).

[0026] The device may comprise a connector **74**, and holes **9'** near the bottom of the front face to improve pick-up by the microphone. Holes **9'** also favor sampling of ambient air for the purpose of air quality sensing as detailed below.

[0027] Advantageously according to the invention, the camera **2** periodically captures video images **5** of the baby **B**. The image capture frequency will be a few hertz or tens of hertz, preferably higher than 8 Hz. It should be noted that in the context of the invention the same camera is used to capture images in daylight and images in the dark.

[0028] An optical filter may be provided having two positions, i.e. a day position and a night position.

[0029] The device controls excitation of the infrared LEDs **3** either continuously or at times coinciding and consistent with the capture of images. The infrared LEDs are arranged so as to substantially illuminate the entire solid angle of view of the camera.

[0030] Advantageously in the case of baby monitoring, the method for image processing and analysis will seek to determine the position of the baby's head **T**.

[0031] To do so, a step of the method, denoted **B1**, consists of detecting edges or edge segments in one or more successive images captured by the camera.

[0032] For each image, spatial convolution with statistical thresholding is performed, or calculation of the correlation to the mean of the red component or of the configured mix of colors. This allows identifying and memorizing the curve portions **61,62,63,64** where the spatial gradient of the signal is the highest, corresponding in practice to edge segments within the image.

[0033] Identification of these edge segments can be confirmed by sequential analysis of several successive images; if similar edge segments are found at the same location in these multiple images, then the determination is confirmed.

[0034] Otherwise it may concern a macroscopic movement of the baby, a case which will be explained below.

[0035] When sequential analysis of several successive

images has confirmed the presence of several edge segments, we proceed to the next step in which several edge segments are associated and together they are compared to an elliptical shape (ellipse) with which said several edge segments might match.

[0036] A relevance criterion is established for quantifying the correspondence of the combined edge segments **62,64** with the candidate ellipse.

[0037] Of course, if a continuous outline is found which forms a circle or a closed ellipse in the analyzed image, then the relevance criterion will assume the maximum value; but in practice often the image analysis only detects portions of the candidate ellipse, and the ellipse must be reconstructed and assigned a relevance criterion value.

[0038] This step, referenced **B2**, may in addition identify a plurality of candidate ellipses, in which case a selection filter is applied to the candidate ellipses to choose only one selected ellipse **6** coinciding with the outline of the baby's head **T**. This filter may use the size of the ellipse, the ratio of its major axis to minor axis, and also the proportion of the outline actually found in the previous step.

[0039] In the typical case of one head to be detected, the selection of such a selected ellipse **6** allows eliminating from the subsequent analysis all image areas outside of the ellipse, and defining an area of interest centered on the ellipse.

[0040] Once the area of interest has been determined, and subject to the baby making no significant movements (see below), then the step denoted **C** of the method is carried out, this step corresponding to a photoplethysmographic analysis intended to determine vital signs of the baby, particularly the heart rate **HR** but also the respiratory rate **RR**.

[0041] Advantageously, one can determine a first area of interest **7** for evaluating the heart rate (e.g. forehead), and a second area of interest that may be distinct from the first, for evaluating the respiratory rate.

[0042] Preferably, for the heart rate determination, first there is applied to the light signal spatially averaged over the first area of interest, a sliding-window based offset calculation to eliminate the continuous component of the signal. This results in a signal denoted **80** in [figure 7](#), which remains relatively noisy but no longer contains a continuous component.

[0043] Next, a digital filter with passband of 0.75 Hz - 3.5 Hz is applied to the signal **80** in order to obtain a filtered signal **81**. This eliminates spurious signals outside the frequency band of interest.

[0044] A peak detection step is then applied to the resulting filtered signal **81**. This processing is intended to find the peaks **86** (only the first ones are indicated by crosses in [figure 7](#)).

[0045] The time interval between each consecutive peak **86** allows calculating the heart rate as illustrated in [curve 82](#).

[0046] Optionally, a validity criterion relating to the rel-

evance of the filtered signal **8** may be defined, to be used for selectively validating or not validating the heart rate information. This validity criterion may be based on the signal-to-noise ratio (S/N) of the signal **81**.

[0047] A filtered and corrected signal is denoted **83**.

[0048] If the heart rate value from step **C** satisfies the validity criterion, this value may be stored in memory and/or transmitted to a remote device **22** such as a smartphone connected by wireless link to the monitoring device **1**.

[0049] Step **C** is carried out almost continuously, repeating periodically, for example obtaining a measurement every 5 seconds or every 10 seconds, knowing that to obtain each measurement, when appropriate, the device can increase the rate at which it captures images in the area of interest.

[0050] In parallel to step **C**, the method monitors that the baby is remaining substantially motionless, or in other words that the edge segments identified in step **B1** remain substantially stable.

[0051] A special case is handled by the method according to the invention: when there is significant (macroscopic) movement of the baby. In this case, the baby's head moves, and the head's position must be determined again.

[0052] Detection of a significant movement of the baby can be achieved by analysis of the position of the edge segments and their evolution over successive images. Additionally or alternatively, the information provided by the microphone **9** can also be used, because a macroscopic motion of the baby will generate audio signals received by the microphone.

[0053] Those skilled in the art understand that a plethysmographic analysis cannot yield valid results when the baby is making significant movements.

[0054] However, it is arranged that the evolution of these movements are monitored (the step denoted **D**) in order to identify a return to a stable state where there is no significant movement by the baby, in which case steps **B1-B2** are performed again, step **C-** of photoplethysmographic analysis being repeated with the new area of interest **7** established in step **B2**.

[0055] The abovementioned processing may be performed on the entire captured image **5**. However, as a variant, the image may be subdivided to limit the computation resources required and the memory required. For example, the captured image **5** can be divided into an array of sub-images **50**, each sub-image **50** being the same size to facilitate processing. In the illustrated example, the captured image is divided into 5x5 sub-images.

[0056] This has the advantage that certain images of flat or neutral content **50a** (meaning with no significant variation in color or intensity over the area of the sub-image) can be eliminated during the edge detection in step **B1**. One criterion for eliminating the sub-images **50** of no interest can be based on a low light intensity and/or a low variation in the analyzed area.

[0057] Now referring to [figure 8](#), since steps **B1-B2** have identified an area of interest, the transition **96** initializes the plethysmographic analysis (C-), and this is repeated (denoted **95**) as long the baby is not moving. If the baby moves, then the plethysmographic analysis is suspended **97,98** and the step of monitoring the macroscopic movements (step **D**) puts the plethysmographic process on hold until a stable state is restored, illustrated by transition **99**. Then the method restarts steps **B1-B2**, and then proceeds to step **C-**.

[0058] It should also be noted that the device installation does not require any special precautions, as automatic detection of the baby's head is possible even if the framing by the camera is not perfect relative to the crib.

[0059] It should be noted that the method for detecting the baby's head as disclosed above can also function in the daytime under natural lighting, and not only under dark illumination conditions.

[0060] The video monitoring device **1** further comprises a volatile organic compounds sensor **37** (known as a 'VOC' sensor). Such a sensor can detect several organic gases, such as butane, propane, octane, methanol, ethanol, propanol, butanol, and even aromatic compounds such as benzene, ethylbenzene, and toluene. The baby monitoring device may record the concentration of organic compounds during one or more periods of time, and send this information either in real time or in deferred mode to the smartphone **22**.

[0061] Also the volatile organic compounds sensor **37** can detect hydrogen sulfide (H₂S) concentration.

[0062] Regarding VOCs, some organic compounds can be released at home by cosmetics, cleaning products, fresh paint, new piece of furniture, they can include aldehydes, formaldehyde, methylene, toluene, acetone, butene, pentane, benzene or the like.

[0063] The VOC sensor **37** in question is an electrochemical MOS on-chip sensor. The sensing element comprises a metal oxide semiconductor layer reacting with VOCs by oxydation-reduction reactions. In the presence of a detectable gas, the conductivity of the metal-oxide semiconductor increases depending on the gas concentration in the air. A simple electrical circuit converts this conductivity into an output voltage which is measured. This voltage is then converted into a concentration level of VOCs in the room by the microcontroller. This conversion may be done by looking at a calibration look-up table, or by calculating a calibration function, and possibly after adjusting for other quantities provided by other sensors, for instance the temperature and/or humidity.

[0064] The VOC sensor **37** can alternatively be an ion detector using photoionization of the molecules in an air sample collected in the room where the baby's crib is located.

[0065] The VOC sensor **37** provides an aggregate level of organic compounds which combines all the organic compounds present.

[0066] Advantageously, the already mentioned humid-

ity sensor **27** is used to compensate for the possible presence of water vapor in the sampled air and for correcting accordingly the sensed VOC concentration level.

[0067] Advantageously, since the VOC concentration level(s) is(are) transmitted to smartphone user, he/she can decide to ventilate/air the room in which the device is located. Furthermore, a VOC scale can be provided on a smartphone application to help the user decide whether it is required to ventilate/air the room.

[0068] Regarding the case of monitoring the baby, collected values of predefined period of time can be used to correlate the heart rate HR and/or respiratory rate RR with the VOC concentration levels in order to determine if the baby was affected by a certain level of VOCs at some time.

[0069] In addition, a detection sheet **72** may be provided that acts as a motion sensor, as shown in [figure 9](#). This detection sheet **72** is installed on the mattress and the baby **B** is placed above it, in other words the detection sheet **72** is placed between the baby **B** and the mattress. The detection sheet may comprise a signal conditioning interface **77** and is connected to the monitoring device **1** by a flexible link **73**, either electrical or pneumatic or a combination. This link **73** is connected to the device via the connector **74**. The signal conditioning may be performed by the conditioning interface **77** or even directly wholly or in part by the monitoring device itself.

[0070] In the example illustrated, the detection sheet is formed by a thin air bladder, which allows detecting the baby's movements by ballistography.

[0071] To help the baby fall asleep more quickly and more easily, atmospheric lighting is provided by the atmospheric lighting means **23** and soft music through the speaker **19**, both of them preferably decreasing in intensity.

[0072] To trigger the light and sound sequence, the beginning of the drowsiness phase can be detected by video determination of the heart rate as explained above. When the heart rate **82** slows and becomes more regular, then the control unit **4** triggers the light and sound sequence.

[0073] Alternatively, the computing unit uses not only the heart rate information but also the respiratory rate information detected for example by means of the microphone **9** and/or of said detection sheet **72**. The computing unit **4** may also use video detection of movements of the baby's head **T** by means of the edge detection method as explained above.

[0074] When the computing unit **4** has triggered the sound and light sequence to assist with falling asleep and the baby starts to move about or to cry, then the sequence can be extended or restarted at the beginning.

[0075] If the sound and light sequence comes to an end with no change in the heart rate and with no movement of the baby, then the monitoring device turns the atmospheric lighting completely off and switches to night monitoring mode.

[0076] In a particular aspect, the video monitoring de-

vice can save the highlights of the day and/or night, in other words it can save images of events which occurred earlier; for example, based on detection of movement near the baby, saving images and audio whenever someone enters or leaves the room, and based on detection of crying, saving images and audio whenever the baby starts to cry, whenever there is a significant change in environmental parameters, whenever the baby smiles, etc.

[0077] According to a particular aspect, the video monitoring device can generate an alert sent to a remote device such as a smartphone or other device, upon detection of abnormal conditions such as environmental parameters exceeding preset thresholds, an unusually quiet or unusually restless environment, movement, pollution detection, etc.

[0078] Lastly, according to a particular aspect, the video monitoring device can be equipped with a two-way simultaneous audio connection, in other words a full-duplex connection, which allows the parent(s) and baby to exchange words or sound signals truly at the same time.

[0079] As a variant, instead of a baby, the video monitoring device can simply monitor what happens generally in a room of a home.

Claims

1. Video monitoring device (1) comprising a computing unit (4), a camera (2), a communication interface (42), and a volatile organic compounds sensor (37) configured to measure at least a concentration of organic compounds in a room of interest, said computing unit being configured to record the concentrations of organic compounds reported by the volatile organic compounds sensor, and configured to send images taken by the camera and volatile organic compounds concentrations to a remote entity, such as a smartphone (22) over a wireless link.
2. Video monitoring device according to claim 1, wherein the volatile organic compounds sensor (37) configured to detect multiple organic gases, such as butane, propane, octane, methanol, ethanol, propanol, butanol, and even aromatic compounds such as benzene, ethylbenzene, and toluene.
3. Video monitoring device according to any of claims 1-2, wherein the computing unit stores successive organic compound concentration level value in memory, for transmission at regular intervals to the remote entity.
4. Video monitoring device according to any of claims 1-3, wherein an alert threshold is provided in the computing unit, which allows to send immediately to the smartphone an alert message, as soon as the VOC concentration level exceeds the predetermined alert threshold.
5. Video monitoring device according to any of claims 1-4, wherein the VOC sensor (37) is an electrochemical MOS on-chip sensor using oxydation-reduction reactions with gas(es) present in ambient air, whereby a VOC concentration level can be measured.
6. Video monitoring device according to any of claims 1-5, wherein the VOC sensor provides an aggregate level of organic compounds which combines all the organic compounds present in the air of the room.
7. Video monitoring device according to any of claims 1-6, wherein some vital signs of a baby, such as the heart rate (HR) and/or respiratory rate (RR) of the baby are evaluated by photoplethysmographic analysis of the captured images, thereby forming a device suitable for monitoring a baby in a room or in a crib.
8. Video monitoring device according any of claims 1-7, further comprising a loudspeaker and a microphone, thereby forming two-way audio link, particularly suitable for interacting with a baby in a room or in a crib, remotely from a parent/caretaker using the smartphone.
9. Video monitoring system comprising a monitoring device (1) according any of claims 1-8, and a smartphone (22).
10. Method to monitor events in a room and an air quality in the room, the method comprising:
 - measuring a concentration of organic compounds in a room with a volatile organic compounds sensor (37)
 - taking images of at least part of the room,
 - storing the organic compound concentration data in a memory of a computing unit (4),
 - send images taken by the camera and volatile organic compounds concentrations, from the computing unit to a remote entity such as a smartphone (22) over a wireless link.
11. Method to according to claim 10, wherein the transmission to the smartphone occurs at regular intervals.
12. Method to according to claim 10, wherein an alert threshold is provided in the computing unit, the method further comprising:
 - sending quickly to the smartphone an alert message, as soon as the VOC concentration exceeds the predetermined alert threshold.

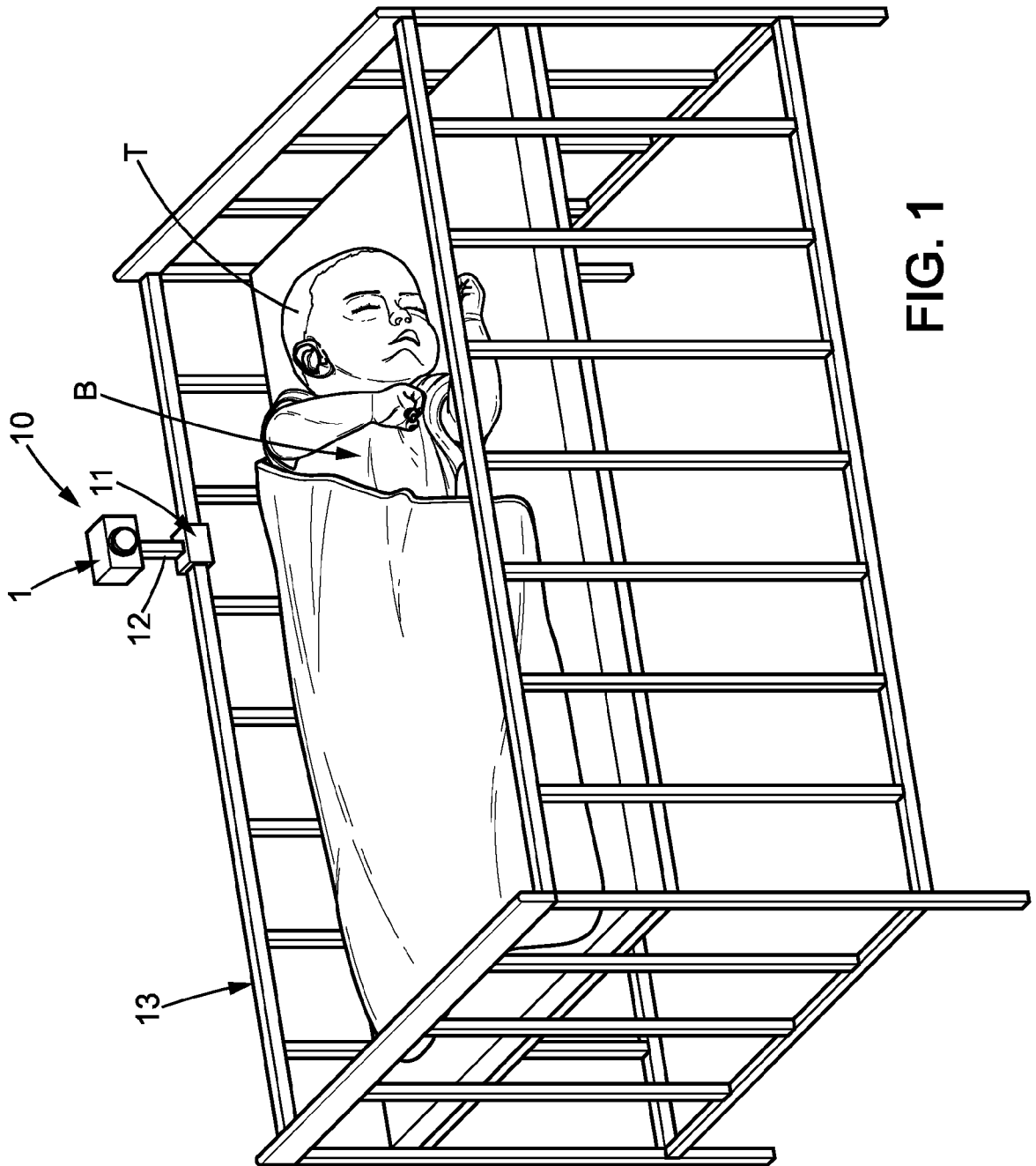

FIG. 1

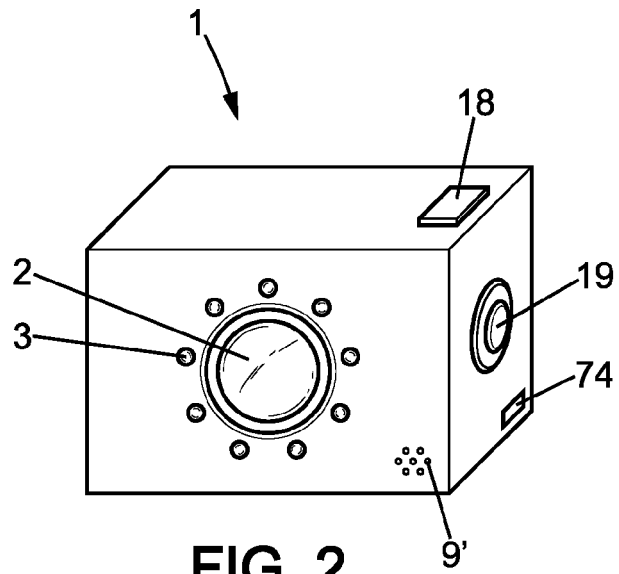

FIG. 2

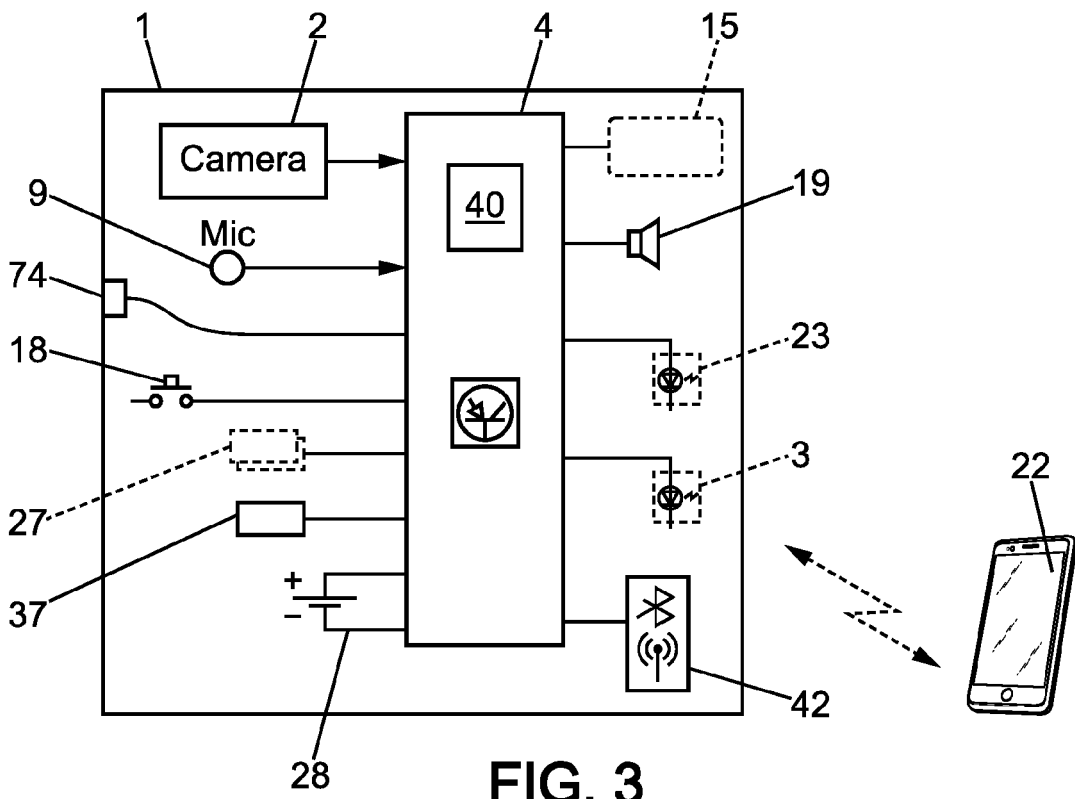

FIG. 3

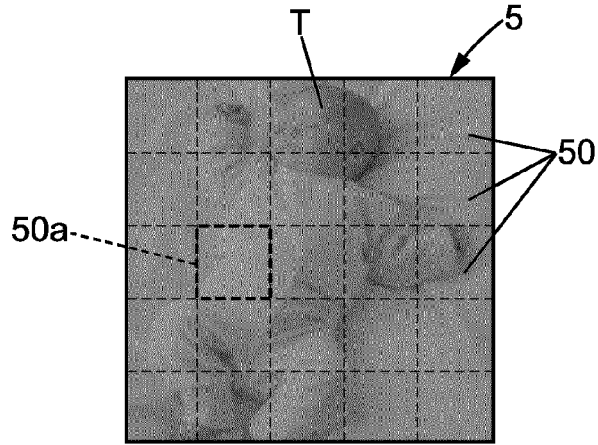

FIG. 4

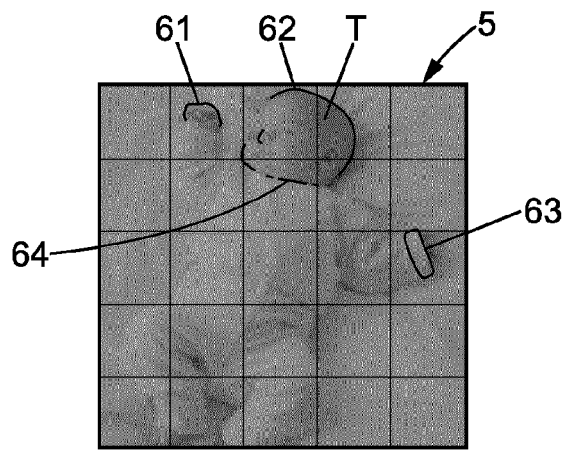

FIG. 5

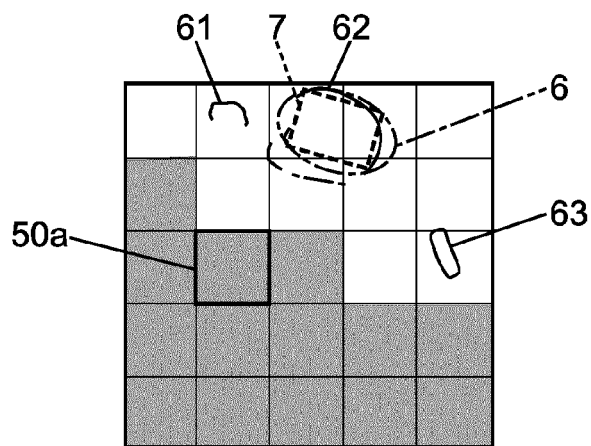

FIG. 6

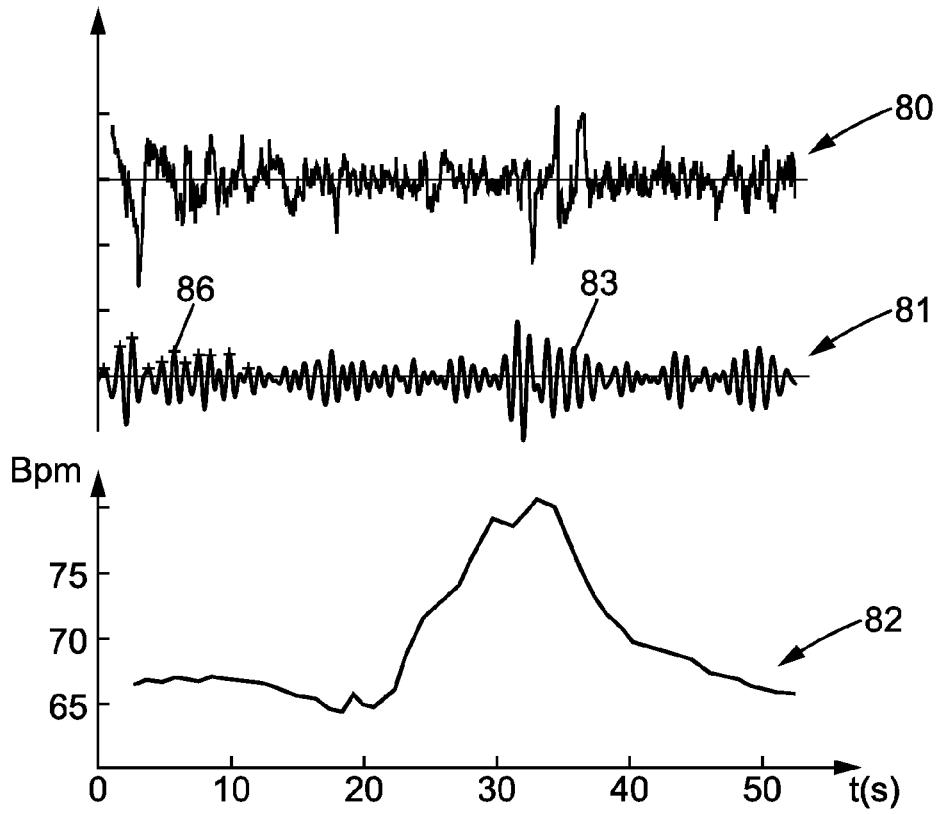

FIG. 7

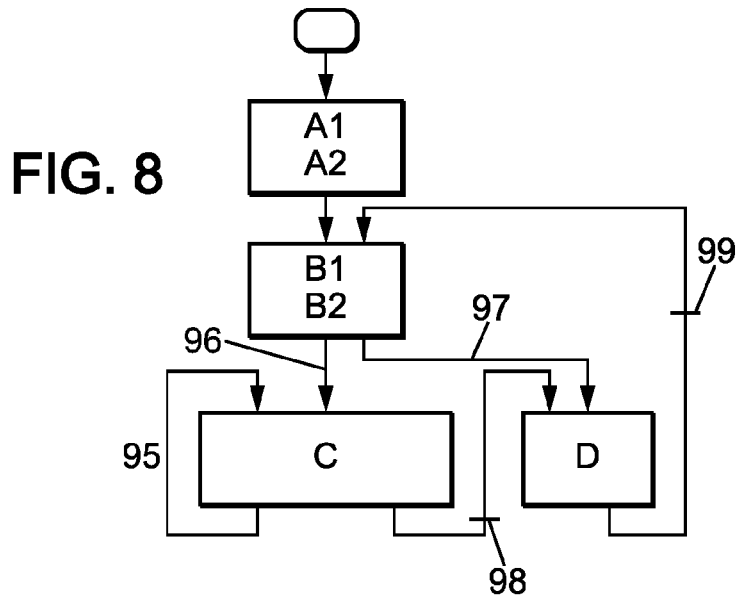

FIG. 8

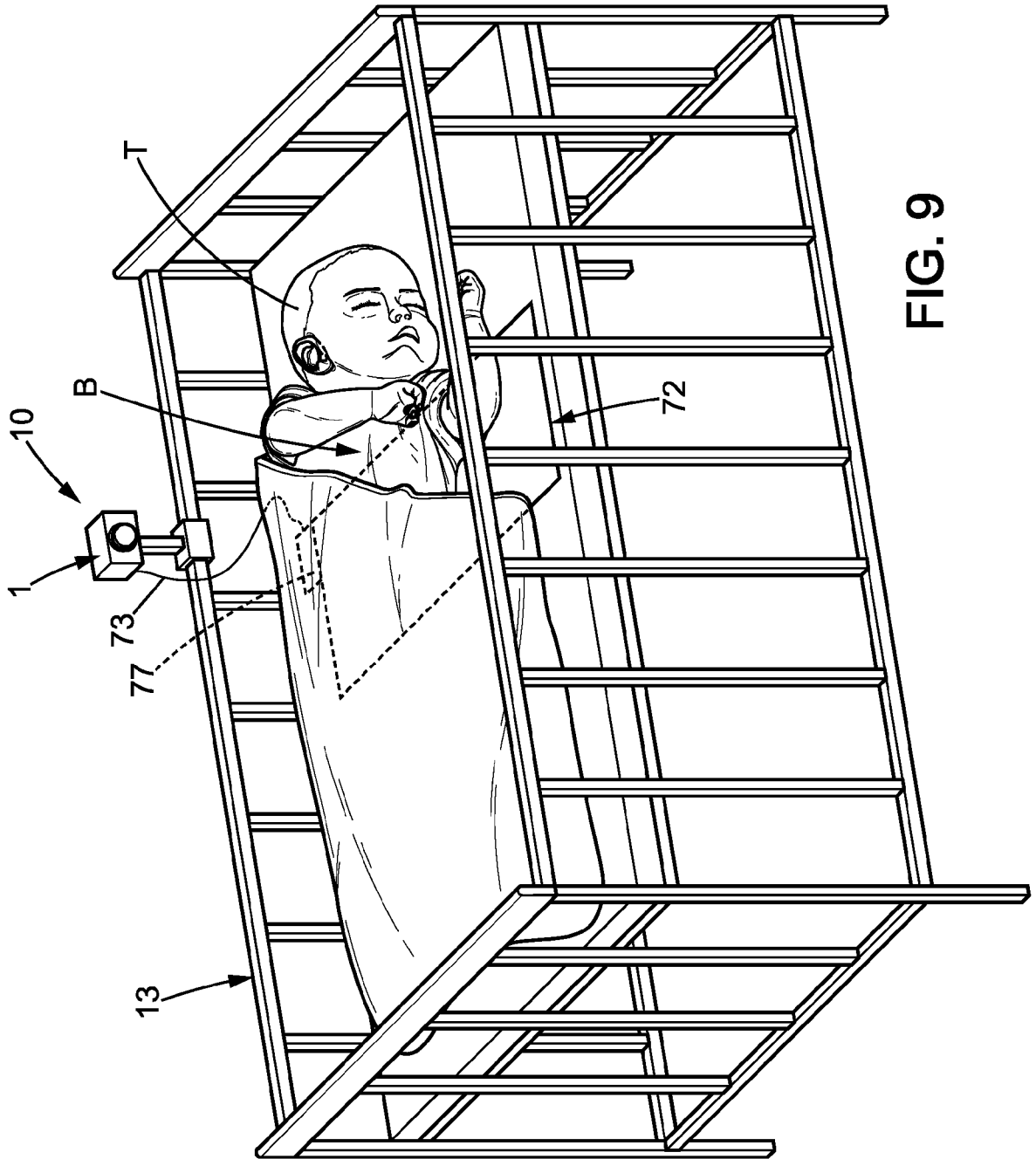

FIG. 9



EUROPEAN SEARCH REPORT

Application Number
EP 15 17 7627

5

10

15

20

25

30

35

40

45

DOCUMENTS CONSIDERED TO BE RELEVANT			
Category	Citation of document with indication, where appropriate, of relevant passages	Relevant to claim	CLASSIFICATION OF THE APPLICATION (IPC)
X,P	Rich Gallagher ET AL: "Withings Introduces Home", f, 4 September 2014 (2014-09-04), XP055229932, Retrieved from the Internet: URL:http://vitrine-media-cdn.withings.com/wysiwyg/news_events/Withings_Home_press%20release_040914_US.pdf [retrieved on 2015-11-20]	1-4,8-12	INV. G08B21/00 A61B5/00
Y,P	* the whole document * -----	7	
X,P	Ams Ag: "Withings room monitor helps keep air quality high indoors thanks to MEMS VOC gas sensor from ams, PR", 8 April 2015 (2015-04-08), XP055229922, Retrieved from the Internet: URL:http://ams.com/eng/Press-Center/Press-Releases/AS-MLV-P2_GasSensor [retrieved on 2015-11-20]	1-6, 10-12	
Y,P	* the whole document * -----	7	TECHNICAL FIELDS SEARCHED (IPC)
X	US 2010/225493 A1 (ZISHAAN FAIZ [GB]) 9 September 2010 (2010-09-09)	1-3,10, 11	G08B A61B
Y	* abstract * * paragraphs [0233] - [0261], [0340] - [0347] *	7	
Y	WO 2013/093686 A1 (KONINKL PHILIPS ELECTRONICS NV [NL]) 27 June 2013 (2013-06-27) * abstract; figures 1b,2b * * page 6, lines 7-31 * * page 7, line 18 - page 8, line 2 * ----- -/--	7	
The present search report has been drawn up for all claims			
Place of search Munich		Date of completion of the search 23 November 2015	Examiner Medeiros Gaspar, Ana
CATEGORY OF CITED DOCUMENTS X : particularly relevant if taken alone Y : particularly relevant if combined with another document of the same category A : technological background O : non-written disclosure P : intermediate document		T : theory or principle underlying the invention E : earlier patent document, but published on, or after the filing date D : document cited in the application L : document cited for other reasons & : member of the same patent family, corresponding document	

EPO FORM 1503 03.82 (P04C01)

50

55



EUROPEAN SEARCH REPORT

Application Number
EP 15 17 7627

5

10

15

20

25

30

35

40

45

50

55

DOCUMENTS CONSIDERED TO BE RELEVANT			
Category	Citation of document with indication, where appropriate, of relevant passages	Relevant to claim	CLASSIFICATION OF THE APPLICATION (IPC)
A	US 2013/165809 A1 (ABIR EYALL [IL]) 27 June 2013 (2013-06-27) * abstract; figure 2 * * paragraphs [0010], [0011], [0108], [0111], [0138], [0139] * -----	1,10	
			TECHNICAL FIELDS SEARCHED (IPC)
The present search report has been drawn up for all claims			
Place of search Munich		Date of completion of the search 23 November 2015	Examiner Medeiros Gaspar, Ana
CATEGORY OF CITED DOCUMENTS X : particularly relevant if taken alone Y : particularly relevant if combined with another document of the same category A : technological background O : non-written disclosure P : intermediate document		T : theory or principle underlying the invention E : earlier patent document, but published on, or after the filing date D : document cited in the application L : document cited for other reasons & : member of the same patent family, corresponding document	

EPO FORM 1503 03/82 (P04/C01)

**ANNEX TO THE EUROPEAN SEARCH REPORT
ON EUROPEAN PATENT APPLICATION NO.**

EP 15 17 7627

5

This annex lists the patent family members relating to the patent documents cited in the above-mentioned European search report. The members are as contained in the European Patent Office EDP file on The European Patent Office is in no way liable for these particulars which are merely given for the purpose of information.

23-11-2015

10

Patent document cited in search report	Publication date	Patent family member(s)	Publication date
US 2010225493 A1	09-09-2010	CN 101765747 A	30-06-2010
		EP 2183526 A1	12-05-2010
		GB 2464436 A	21-04-2010
		JP 2010534966 A	11-11-2010
		KR 20100040302 A	19-04-2010
		US 2010225493 A1	09-09-2010
		WO 2009013508 A1	29-01-2009

WO 2013093686 A1	27-06-2013	NONE	

US 2013165809 A1	27-06-2013	US 2013165809 A1	27-06-2013
		WO 2012014215 A1	02-02-2012

15

20

25

30

35

40

45

50

55

EPO FORM P0459

For more details about this annex : see Official Journal of the European Patent Office, No. 12/82

REFERENCES CITED IN THE DESCRIPTION

This list of references cited by the applicant is for the reader's convenience only. It does not form part of the European patent document. Even though great care has been taken in compiling the references, errors or omissions cannot be excluded and the EPO disclaims all liability in this regard.

Patent documents cited in the description

- US 8094013 B [0003]
- WO 2013170035 A [0003]

专利名称(译)	具有挥发性有机化合物传感器的监测装置和使用其的系		
公开(公告)号	EP2977973A1	公开(公告)日	2016-01-27
申请号	EP2015177627	申请日	2015-07-21
[标]申请(专利权)人(译)	WITHINGS		
申请(专利权)人(译)	WITHINGS		
当前申请(专利权)人(译)	WITHINGS		
[标]发明人	CAMPO DAVID CARPENTIER STEPHANE DUMOULIN AMAURY BUARD NADINE CARREEL ERIC		
发明人	CAMPO, DAVID CARPENTIER, STÉPHANE DUMOULIN, AMAURY BUARD, NADINE CARREEL, ERIC		
IPC分类号	G08B21/00 A61B5/00		
CPC分类号	A61B5/02416 A61B5/0816 A61B5/1128 A61B5/4803 A61B5/7207 A61B2503/04 A61B2560/0242 G01N33/0047 G06K9/0053 G06K9/3233 G06T7/0016 G06T7/75 G06T2207/10024 G06T2207/10048 G06T2207/30076 G06T2207/30201 G08B21/0208 A61B5/0004 A61B5/0205 H04N7/185		
代理机构(译)	柜PLASSERAUD		
优先权	2014056996 2014-07-21 FR		
其他公开文献	EP2977973B1		
外部链接	Espacenet		

摘要(译)

视频监控设备 (1)，包括计算单元 (4)，摄像机 (2)，通信接口 (42) 和挥发性有机化合物传感器 (37)，其被配置为测量至少一个室内有机化合物的浓度。感兴趣的是，所述计算单元被配置为记录由挥发性有机化合物传感器报告的有机化合物的浓度，并且被配置为将由相机拍摄的图像和挥发性有机化合物浓度发送到远程实体，例如智能电话 (22)。无线链接。

