

(19)



(11)

EP 2 910 181 B1

(12)

EUROPEAN PATENT SPECIFICATION

(45) Date of publication and mention of the grant of the patent:
06.05.2020 Bulletin 2020/19

(51) Int Cl.:
A61B 5/00 (2006.01) **A61B 5/02** (2006.01)
A61B 5/026 (2006.01) **A61B 5/107** (2006.01)
A61B 5/024 (2006.01)

(21) Application number: **15156119.8**

(22) Date of filing: **23.02.2015**

(54) Apparatus and method for sensing body information

Vorrichtung und Verfahren zur Erfassung von Körperinformationen

Appareil et procédé de détection d'informations d'un corps

(84) Designated Contracting States:
AL AT BE BG CH CY CZ DE DK EE ES FI FR GB GR HR HU IE IS IT LI LT LU LV MC MK MT NL NO PL PT RO RS SE SI SK SM TR

(30) Priority: **24.02.2014 KR 20140021450**

(43) Date of publication of application:
26.08.2015 Bulletin 2015/35

(73) Proprietor: **Samsung Electronics Co., Ltd. Suwon-si, Gyeonggi-do 443-742 (KR)**

(72) Inventors:
 • **Park, Sang-bae Chungcheongbuk-do (KR)**
 • **Lee, Sang-hoon Incheon (KR)**
 • **Jeong, Jae-hoon Gyeonggi-do (KR)**

- **Cho, Kyung-sun Seoul (KR)**
- **Hong, Seong-seol Gyeonggi-do (KR)**
- **Lee, Dong-jin Gyeonggi-do (KR)**
- **Choi, Mi-jin Seoul (KR)**

(74) Representative: **Appleyard Lees IP LLP 15 Clare Road Halifax HX1 2HY (GB)**

(56) References cited:
EP-A2- 2 281 503 WO-A2-2013/001265
WO-A2-2013/019904 JP-A- 2010 061 294
US-A1- 2013 323 673

EP 2 910 181 B1

Note: Within nine months of the publication of the mention of the grant of the European patent in the European Patent Bulletin, any person may give notice to the European Patent Office of opposition to that patent, in accordance with the Implementing Regulations. Notice of opposition shall not be deemed to have been filed until the opposition fee has been paid. (Art. 99(1) European Patent Convention).

Description

BACKGROUND

1. Field

[0001] Apparatuses and methods consistent with exemplary embodiments relate to for sensing body information, and more particularly, to providing an apparatus and method for sensing body information to acquire voluptuousness information (i.e. body volume) and blood flow information of a body.

2. Description of the Related Art

[0002] Due to an increase in aging populations and the development of technologies, various types of medical devices have been provided for users to use in their homes. For example, representative medical devices for homes include devices for measuring a blood sugar level, for measuring a blood pressure, etc. The medical devices may help to manage the health of a user through a portable terminal such as a smartphone or the like. In particular, demands for medical devices for use in homes have been gradually increased according to needs of people for leading healthy and affluent lives.

[0003] Existing devices that measure a heart rate or blood flow information of a human use a transmission type detection method or a reflection type detection method using an infrared (IR) sensor. According to the transmission type detection method, if a light source irradiates light onto a finger, blood, bones, or tissues absorb the light, and the other portion of the light passes through the blood, the bones, or the tissues and then reaches a light receiver. An absorption degree of the light changes with respect to the blood flow due to the heartbeat, in proportion to the amount of skin, tissues, and blood that is positioned within the path of the light. Therefore, the absorption degree of the light is dependent upon, for instance proportional to, the blood flow. Since the light receiver receives transmitted light from which an amount of light absorbed into the finger is subtracted, variations in amount of the transmitted light reflects variations in the blood flow. Therefore, a measurement of an amount of light by the light receiver enables a detection of variations in an amount of blood flow synchronized with the heartbeat. According to the reflection type detection method, a similar blood flow variation detecting method to that of the transmission type detection method is used, but a position of the sensor receiving the light is different from that in the transmission type detection method. In the transmission type detection method, the light-receiving device is installed on a light-emitting device, such that a user's finger is placed between the light-emitting device and the light-receiving device. In the reflection type detection method, the light-receiving device is installed beside the light-emitting device to detect a reflected amount of light with respect to variations in the blood flow in order

to measure the heartbeat.

[0004] There is also an existing device that measures a user's voluptuousness using a 3-dimensional (3D) body scanner. The term voluptuousness as used herein may refer to body volume, body size, body mass, body fat content or the like. However, 3D body scanners are very expensive, and it is difficult to install and use a 3D body scanner in the home. Therefore, there is an existing device that measures voluptuousness by measuring a depth of the user through a depth camera and an image processing algorithm and then calculates the voluptuousness. The depth camera uses a time of flight (TOF) method or a pattern method. The TOF method is the most typical and basic distance measuring method and measures a difference between a time when pulses are emitted and a time when reflected waves are received in order to acquire a distance. Therefore, the TOF method is mainly used in conjunction with radar or an ultrasonic sensor. The pattern method calculates a depth by sensing intervals between IR patterns or deformations and sizes of the IR patterns.

[0005] As described above, a device that measures blood flow information such as a heartbeat or the like of a user and a device that measures voluptuousness such as a body size, body fat, or the like of the user acquires body information of the user by using IR light. Therefore, the two devices use similar methods but are installed separately from each other.

[0006] WO2013/019904 (A2) discloses a disposable light source device for the non-invasive visualization of veins, arteries or other subcutaneous structures of and objects in the body, or for facilitating and monitoring intravenous insertion or extraction of fluids, including a conforming layer for interfacing and optically coupling with the body surface, and adhering the device to the body portion, and a main light source for directing near infrared light through the conforming layer to illuminate the body. The disposable light source device can also include a light transmissive and electrically insulative layer that is disposed between and electrically insulates the main light source from the body- contacting conforming layer.; The disposable light source device can also include a proximity sensor that controls activation of the first light source such that the light source is on only when the conforming layer is brought into proximity to the body surface.

[0007] EP2281503 (A2) discloses a device provided with a laser for exciting a fluorescent imaging agent which emits radiation at a wavelength that causes any of the agent located within the vasculature or tissue of interest irradiated thereby to emit radiation of a particular wavelength. A camera capable of obtaining multiple images over a period of time, such as a CCD camera may be used to capture the emissions from the imaging agent. A band-pass filter prevents the capture of radiation other than that emitted by the imaging agent. A distance sensor incorporates a visual display providing feedback to the physician saying that the laser is located at a distance from the vessel of interest that is optimal for the capture

of high quality images.

[0008] JP2010061294 (A) discloses a room for exercise in association with general house equipment and to function as a trainer in a training gym for regular exercise. The room has a wash zone with a washstand installed therein, and an exercise zone with sports equipment installed therein. The wash zone and the exercise zone are connected without a partition. In the wash zone, a measurement means 17 measuring biological information of a user is installed. The biological information measured by the measurement means is input to an instruction information generation device. Instruction information necessary for physical management is generated in the instruction information generation device. The instruction information generated by the instruction information generation device is presented to operation display devices.

[0009] WO2013001265 (A2) discloses a personal hand-held monitor comprising a signal acquisition device for acquiring signals which can be used to derive a measurement of a parameter related to the health of the user, the signal acquisition device being integrated with a personal hand-held computing device. The present invention also provides a signal acquisition device adapted to be integrated with a personal hand-held computing device to produce a personal hand-held monitor.

SUMMARY

[0010] According to the present invention there is provided an apparatus and method as set forth in the appended claims. Other features of the invention will be apparent from the dependent claims, and the description which follows.

[0011] One or more exemplary embodiments may address at least the above problems and/or disadvantages and other disadvantages not described above. Also, the exemplary embodiments are not required to overcome the disadvantages described above, and an exemplary embodiment may not overcome any of the problems described above.

[0012] The exemplary embodiments provide an apparatus and method for sensing body information to acquire voluptuousness (i.e. body volume) information at long and short distances and acquire blood information at a close or shortest distance.

[0013] According to an aspect of an exemplary embodiment, there is provided an apparatus for sensing body information. The apparatus includes: a light-emitting device configured to emit light to an object that is to be sensed; a light-receiving device configured to detect reflected light reflected from the object; an image sensor configured to detect the reflected light reflected from the object; and a controller configured to selectively drive at least one of the light-receiving device and the image sensor according to a distance between the object and the light-emitting device to acquire the reflected light and sense volume information or blood flow information of

the object by using the reflected light. The light-receiving device may be configured to detect overall intensity of reflected light from the object, and so may comprise a single light detector, or a plurality of light detectors, whereas the image sensor may be arranged to generate information for generation of an image of the object from the reflected light, and so may comprise a plurality of pixel detectors arranged in an array and configured to provide information for generation of an image from the light reflected from the object.

[0014] The term "light" may refer to visible, UV or infrared light, suitably infra-red light having a wavelength for instance from 700nm to 1mm or light visible to the human eye, for instance of wavelength from 390 to 700nm.

[0015] The term "sensing information" as used herein may include detecting a value of a parameter and calculating the information based on the parameter.

[0016] The controller senses the blood flow information of the object in response to the distance between the object and the light-emitting device being within a first distance and senses the volume information of the object in response to the distance between the object and the light-emitting device exceeding the first distance. In other words, the controller is arranged to sense blood flow information when the distance between the object and the light-emitting device is less than or equal to a first distance and to sense the volume information of the object in response to the distance between the object and the light-emitting device exceeding the first distance. The term "within" as used herein, in relation to a distance, means less than or equal to the distance.

[0017] The controller may sense the blood flow information by using the light-receiving device in response to the distance between the object and the light-emitting device being within the first distance and sense the volume information by using one of the light-receiving device and the image sensor in response to the distance between the object and the light-emitting device exceeding the first distance.

[0018] The controller may sense volume information about an area or a portion of the object in response to the distance between the object and the light-emitting device exceeding the first distance and being within a second distance (for instance by using the image sensor or the light-receiving device) and sense volume information about a whole area of the object, in other words the entire object, by using the image sensor in response to the distance between the object and the light-emitting device exceeding the first and second distances. The second distance may be greater than the first distance.

[0019] The controller may activate the image sensor to sense a saturation of the reflected light and selectively selects at least one of the light-receiving device and the image sensor according to a size of the saturation. Based upon the selection, if the light-receiving device is selected, blood flow may be sensed, and if the image sensor is selected, volume information may be sensed, The saturation may vary according to the distance between the

object and the light-emitting device. The term saturation as used herein may refer to the intensity of the detected light, for instance relative to the intensity of light at which the sensor becomes saturated. The image sensor may comprise a plurality of pixel detectors of the image sensor, and the saturation may refer to the intensity averaged, in some manner, over the plurality of pixel detectors.

[0020] The light-emitting device, the light-receiving device, and the image sensor may be integrated into one sensor module. The image sensor may be disposed in center of the sensor module, such as in a central portion of the sensor module. A plurality of light-emitting devices may be disposed in a peripheral area of the image sensor, for instance around the sensor module, and a plurality of the light-receiving devices may be disposed to be paired with the light-emitting devices, for instance adjacent thereto.

[0021] The apparatus may further include a transparent display configured to cover the sensor module to transmit the light signal and the reflected light. The controller may be arranged to display at least one of the blood flow information and the volume information on the transparent display.

[0022] The blood flow information may include heart rate information and artery hardening information, and the volume information (body volume information) may include at least one of a body image, weight information, body circumference information, and a body mass index (BMI) value of the object. The controller may control the transparent display to display at least one of the heart rate information, the artery hardening information, and the body image, the weight information, the body circumference information, and the BMI value of the object.

[0023] In response to a user touching the transparent display, the controller may determine that the distance between the object and the light-emitting device may be within the first distance to sense the blood information of the object.

[0024] The apparatus may further include a communicator configured to communicate with an external display apparatus, such as a display apparatus connected wirelessly or otherwise (such as directly cabled) to the communicator of the apparatus. The controller may be arranged to transmit one of the volume information and the blood flow information to the external display apparatus.

[0025] According to an aspect of another exemplary embodiment, there is provided a method of sensing body information. The method includes: determining a distance between an object that is to be sensed and a light-emitting device that emits light to the object; selectively driving at least one of a light-receiving device and an image sensor to detect reflected light reflected from the object according to the distance between the object and the light-emitting device in order to acquire the reflected light; and sensing volume information and blood flow information of the object by using the reflected light.

[0026] In response to the distance between the object

and the light-emitting device being within a first distance, the blood flow information of the object is sensed, and in response to the distance between the object and the light-emitting device being exceeding, the volume information of the object is sensed.

[0027] In response to the distance between the object and the light-emitting device being with the first distance, the blood flow information may be sensed by using the light-receiving device, and in response to the distance between the object and the light-emitting device exceeding the first distance, the volume information may be sensed by using one of the light-receiving device and the image sensor.

[0028] In response to the distance between the object and the light-emitting device exceeding the first distance and being within a second distance, volume information about an area of the object may be sensed by using the light-receiving device, and in response to the distance between the object and the light-emitting device exceeding the first and second distances, volume information about a whole area of the object may be sensed by using the image sensor.

[0029] The image sensor may be activated to sense a saturation of the reflected light, and the distance between the object and the light-emitting device may be determined according to a size of the saturation.

[0030] The light-emitting device, the light-receiving device, and the image sensor may be integrated into one sensor module. The image sensor may be disposed in center of the sensor module, such as in a central portion thereof, and a plurality of light-emitting devices may be disposed in a peripheral area of the image sensor, such as arranged around the sensor module, and a plurality of the light-receiving devices may be disposed to be paired with the light-emitting devices, for instance adjacent thereto.

[0031] The method may further include: displaying at least one of the blood flow information and the volume information on a transparent display.

[0032] The blood flow information may include heart rate information and artery hardening information, and the volume information may include at least one of a body image, weight information, body circumference information, and a BMI value of the object. At least one of the heart rate information, the artery hardening information, and the body image, the weight information, the body circumference information, and the BMI value of the object may be displayed on the transparent display.

[0033] In response to a hand of a user touching the transparent display, the distance between the object and the light-emitting device may be determined as being within the first distance.

[0034] The method may further include: transmitting one of the volume information and the blood flow information to an external display apparatus.

[0035] According to an aspect of another exemplary embodiment, there is provided an apparatus for sensing body information. The apparatus may include: at least

one light-emitting device configured to emit light to an object that is to be sensed; at least one light-receiving device configured to detect reflected light reflected from the object; an image sensor configured to detect the reflected light reflected from the object; and a controller configured to selectively operate in one of a first operation mode for sensing blood flow information of the object by using the light-receiving device, a second operation mode for sensing volume information of the object by using the light-receiving device, and a third operation mode for sensing the volume information of the object by using the image sensor.

BRIEF DESCRIPTION OF THE DRAWINGS

[0036] For a better understanding of the invention, and to show how embodiments of the same may be carried into effect, reference will now be made, by way of example, to the accompanying diagrammatic drawings in which:

FIG. 1 is a block diagram illustrating a structure of an apparatus for sensing body information, according to an exemplary embodiment;

FIGS. 2A through 2C are views illustrating a structure of an apparatus for sensing body information in detail, according to an exemplary embodiment;

FIG. 3 is a view illustrating a structure of an image sensor, according to an exemplary embodiment;

FIG. 4 is a view illustrating a method of acquiring voluptuousness information (i.e. body volume) of a user at a long distance, according to an exemplary embodiment;

FIG. 5 is a view illustrating a method of acquiring voluptuousness information (i.e. body volume) of a user at a short distance, according to an exemplary embodiment;

FIGS. 6A through 6C are views illustrating a method of acquiring blood flow information of a user, according to an exemplary embodiment;

FIGS. 7A and 7B are views illustrating a process of displaying body information of a user, according to an exemplary embodiment;

FIG. 8 is a flowchart briefly illustrating a method of sensing body information, according to an exemplary embodiment;

FIG. 9 is a flowchart illustrating a method of sensing body information, according to another exemplary embodiment;

FIG. 10 is a block diagram illustrating a structure of an apparatus for sensing body information, according to another exemplary embodiment;

FIGS. 11 and 12 are views illustrating a process of displaying body information, which is sensed by an apparatus for sensing body information, on an external display apparatus, according to an exemplary embodiment;

FIGS. 13 and 14 are a view and a flowchart illustrat-

ing a method of acquiring motion information of a user through an apparatus for sensing body information to control an external apparatus, according to an exemplary embodiment; and

FIGS. 15 and 16 are views illustrating a process of transmitting body information, which is sensed by an apparatus for sensing body information, to an external service to provide a body management service to a user, according to an exemplary embodiment.

DETAILED DESCRIPTION OF THE EXEMPLARY EMBODIMENTS

[0037] Exemplary embodiments are described in greater detail with reference to the accompanying drawings.

[0038] In the following description, the same drawing reference numerals are used for the same elements even in different drawings. The matters defined in the description, such as detailed construction and elements, are provided to assist in a comprehensive understanding of the exemplary embodiments. Thus, it is apparent that the exemplary embodiments can be carried out without those specifically defined matters. Also, well-known functions or constructions are not described in detail since they would obscure the exemplary embodiments with unnecessary detail.

[0039] FIG. 1 is a block diagram briefly illustrating a structure of an apparatus 100 for sensing body information, according to an exemplary embodiment. Referring to FIG. 1, the apparatus 100 includes a light-emitting device 110, a light-receiving device 120, an image sensor 130, and a controller 140.

[0040] The light-emitting device 110 emits a light signal to an object (e.g., a body or the like) that is to be sensed. Here, the light-emitting device 110 may emit an infrared (IR) light signal, but this is only exemplary. Therefore, the light-emitting device 100 may emit other types of light signals.

[0041] The light-receiving device 120 detects light reflected from the object under control of the controller 140. Here, the light-receiving device 120 may be disposed to be paired with the light-emitting device 110.

[0042] Under control of the controller 140, the image sensor 130 detects light reflected from the object. Here, the light-emitting device 110, the light-receiving device 120, and the image sensor 130 may be integrated into one sensor module. Also, the image sensor 130 may be disposed in the center of the sensor module, and a plurality of light-emitting devices 110 and a plurality of light-receiving devices 120 may be disposed in a peripheral area of the image sensor 130.

[0043] The controller 140 selectively drives at least one of the light-receiving device 120 and the image sensor 130, according to a distance between the object and the light-emitting device 110, to acquire a reflected light signal and sense voluptuousness information (i.e. body volume) and/or blood flow information of the object by using

the reflected light signal.

[0044] In detail, the controller 140 determines the distance between the object and the light-emitting device 110. Here, the controller 140 may activate the image sensor 130 to sense a saturation of the reflected light signal and determine the distance between the object and the light-emitting device 110 according to an amount of the saturation. In detail, if the saturation of the reflected light signal sensed by the image sensor 130 is higher than or equal to a preset first value, the controller 140 may determine the distance between the object and the light-emitting device 110 as a first distance. If the saturation of the reflected light signal sensed by the image sensor 130 is lower than the preset first value or is higher than or equal to a preset second value, the controller 140 may determine that the distance between the object and the light-emitting device 110 exceeds a first distance and is shorter than or equal to a second distance. Also, if the saturation of the reflected light signal sensed by the image sensor 130 is lower than the preset second value, the controller 140 may determine that the distance between the object and the light-emitting device 100 exceeds the second distance.

[0045] Also, the controller 140 may drive one of the light-receiving device 120 and the image sensor 130 according to the distance between the object and the light-emitting device 110 to sense one of the voluptuousness (i.e. body volume) information and the blood flow information of the object. In detail, if the distance between the object and the light-emitting device 110 is within the first distance, the controller 140 senses the blood flow information of the object. If the distance between the object and the light-emitting device 110 exceeds the first distance, the controller 140 senses the voluptuousness information (i.e. body volume) of the object. Here, if the distance between the object and the light-emitting device 110 is within the first distance, the controller 140 may sense the blood information by using the light-receiving device 120. If the distance between the object and the light-emitting device 100 exceeds the first distance, the controller 140 may sense the voluptuousness information by using one of the light-receiving device 120 and the image sensor 130. A method of sensing the voluptuousness information (i.e. body volume) of the object will now be described in more detail. If the distance between the object and the light-emitting device 110 exceeds the first distance and is within the second distance, the controller 140 may sense the voluptuousness information (i.e. body volume) of an area (e.g., a face, a lower body, or the like) of the object by using the light-receiving device 120. If the distance between the object and the light-emitting device 110 exceeds the first and second distances, the controller 140 may sense the whole voluptuousness information (i.e. body volume) of the object by using the image sensor 130.

[0046] Therefore, through the apparatus 100 for sensing the body information as described above, a user may simultaneously acquire blood flow information and vo-

luptuousness information (i.e. body volume) to perform a comprehensive health assessment of the user.

[0047] An apparatus 200 for sensing body information will now be described in more detail with reference to FIGS. 2A through 7B. FIG. 2 is a block diagram illustrating a structure of the apparatus 200 for sensing body information, according to an exemplary embodiment. Referring to FIG. 2A, the apparatus 200 includes a light-emitting device 210, a light-receiving device 220, an image sensor 230, a controller 240, a transparent display 250, a communicator 260, and a storage unit 270.

[0048] The light-emitting device 210 emits a light signal to an object that is to be sensed, to acquire body information of the object. Here, the light signal may be an IR light signal, but this is merely exemplary. Therefore, other types of light signals (e.g., visible light, etc.) or an ultrasonic wave may be used.

[0049] The light-receiving device 220 detects reflected light acquired by reflecting the light signal emitted from the light-emitting device 210 from the object. The light-receiving device 220 may be disposed to be paired with the light-emitting device 210. In an operation mode in which the light-receiving device 220 is driven, the light-emitting device 210 and the light-receiving device 220 may sequentially operate to acquire volume information about an area of the object.

[0050] The image sensor 230 detects the reflected light that is acquired by reflecting the light signal emitted from the light-emitting device 210 from the object. Also, in an operation mode in which the image sensor 230 is driven, the image sensor 230 may acquire the reflected light to acquire volume information about a whole area of the object. The image sensor 230 may also detect a saturation of the reflected light acquired by reflecting the light signal emitted from the light-emitting device 210 from the object in order to measure a distance between the object and the light-emitting device 210.

[0051] The image sensor 230 will now be described in more detail. As shown in FIG. 3, two light-receiving parts or pixel detectors are paired in each of a plurality of cells of the image sensor 230. Here, the light-receiving parts or pixel detectors may sense the reflected light reflected from the object. Also, the light-receiving parts may include in-phase light-receiving parts and out-phase light-receiving parts. The in-phase light-receiving parts may be activated only in an in-phase status to receive the reflected light, and the out-phase light-receiving parts may be activated only in an out-phase status to receive the reflected light.

[0052] The light-emitting device 210, the light-receiving device 220, and the image sensor 230 may be integrated into one sensor module. In particular, as shown in FIG. 2B, the image sensor 230 may be disposed in center of the sensor module, and light-emitting devices 210-1 through 210-4 and light-receiving devices 220-1 through 220-4 may be disposed in a peripheral are of the image sensor 230 and may be paired with each other. Here, the light-emitting devices 210-1 through 210-4 and

the light-receiving devices 220-1 through 220-4 make four pairs, but this is only exemplary. The light-emitting devices 210-1 through 210-4 and the light-receiving devices 220-1 through 220-4 may make a plurality of pairs. In particular, as the number of light-emitting devices and the number of light-receiving devices increase, volume information of the object may be more precisely acquired.

[0053] The transparent display 250 displays various types of user interfaces (UIs) of the body information under control of the controller 240. In detail, the transparent display 250 may display information related to blood flow information such as heart rate information and artery hardening information and information related to volume information such as a body image, weight information, body circumference information, body mass index (BMI) information, etc. of the object. The transparent display 250 may display a content that is received through the communicator 260.

[0054] As shown in FIG. 3, the transparent display 250 may be positioned on a front surface of the sensor module. Therefore, the transparent display 250 may transmit the light signal emitted from the light-emitting device 210 of the sensor module and the reflected light reflected from the object.

[0055] The transparent display 250 may include a touch sensor. If the transparent display 250 includes the touch sensor, and a hand of a user touches the transparent display 250, the controller 240 may determine that the distance between the light-emitting device 210 and the object is within a first distance.

[0056] The transparent display 250 may be positioned on at least one side of a shower booth.

[0057] The communicator 260 is an element that communicates with various types of external apparatuses according to various types of communication methods. The communicator 260 may include any of various types of communication chips such as a WiFi chip, a Bluetooth chip, a near field communication (NFC) chip, a wireless communication chip, an IR chip, etc. The WiFi chip, the Bluetooth chip, the NFC chip, and the IR chip respectively perform communications according to a WiFi method, a Bluetooth method, an NFC method, and an IR method. The NFC chip refers to a chip that operates according to an NFC method using a band of 13.56MHz among various radio frequency identification (RFID) frequency bands such as 135KHz, 13.56MHz, 433MHz, 860-960MHz, 2.45GHz, etc. If the WiFi chip or the Bluetooth chip is used, the communicator 260 may transmit and receive various types of connection information such as subsystem identification (SSID), a session key, etc. to perform communication connections by using the various types of connection information and then transmit and receive various types of information. The wireless communication chip refers to a chip that perform communications according to various types of communication standards such as IEEE, Zigbee, 3rd Generation (3G), 3rd Generation Partnership Project (3GPP), Long Term Evolution (LTE), etc.

[0058] In particular, the communicator 260 may transmit the body information sensed under control of the controller 240 to an external display apparatus. The communicator 260 may also transmit control information for controlling an external apparatus to the external apparatus.

[0059] The storage unit 270 stores various types of modules for driving the apparatus 200. For example, the storage unit 270 may store software including a base module, a sensing module, a communication module, a presentation module, and a service module. The base module processes signals transmitted from respective pieces of hardware included in the apparatus 200 and transmits the processed signals to an upper layer module. The sensing module collects information from various types of sensors, and analyzes and manages the collected information. The sensor module may also include a face recognition module, a voice recognition module, a motion recognition module, an NFC module, etc. The presentation module constitutes a display screen and may include a multimedia module for playing and outputting a multimedia content and a UI rendering module for processing a UI and a graphic. The communication module communicates with an external source. The service module includes various types of applications for providing various services.

[0060] In particular, the storage unit 270 may include a distance information sensing module, a volume information sensing module, and a blood flow information sensing module to acquire the body information of the object.

[0061] The controller 240 may control the apparatus 200 by using various types of modules and programs stored in the storage unit 270. In particular, the controller 240 may selectively drive at least one of the light-receiving device 220 and the image sensor 230 according to the distance between the object and the light-emitting device 210 to acquire a reflected light signal and sense volume information or blood flow information of the object by using the reflected light signal.

[0062] In detail, the controller 240 may measure the distance between the object and the light-emitting device 210. In particular, in order to measure the distance between the object and the light-emitting device 210, the controller 240 may activate the image sensor 230 to sense the reflected light that is acquired by reflecting the light signal emitted from the light-emitting device 210 from the object. The controller 240 may also calculate a saturation of the reflected light sensed by the image sensor 230 to measure the distance between the object and the light-emitting device 210. If the saturation is higher than or equal to a preset first value, the controller 240 may determine that the distance between the object and the light-emitting device 210 is within a first distance. The first distance may be a thickness of the transparent display 250. If the saturation is lower than the preset first value and higher than or equal to a preset second value, the controller 240 may determine that the distance between the object and the light-emitting device 210 ex-

ceeds the first distance and is within a second distance. The second distance may be 30cm, but this is only exemplary. Therefore, the second distance may be another value. If the saturation is lower than the preset second value, the controller 240 may determine that the distance between the object and the light-emitting device 210 exceeds the second distance.

[0063] As described above, the measurement of the distance between the object and the light-emitting device 210 by using the saturation of the reflected light sensed by the image sensor 230 is only an exemplary embodiment. Therefore, the distance between the object and the light-emitting device 210 may be measured by using other methods. In detail, if a touch of a user's hand on the transparent display 250 is sensed, the controller 240 may determine that the distance between the object and the light-emitting device 210 is within the first distance. In other words, if the touch of the user's hand on the transparent display 250 is sensed, the controller 240 may determine that the distance between the object and the light-emitting device 210 is the first distance that is the thickness of the transparent display 250.

[0064] The controller 240 may selectively drive one of the light-receiving device 220 and the image sensor according to the distance between the object and the light-emitting device 210 to sense volume information or blood flow information of the object.

[0065] A method of sensing volume information or blood flow information of a user will now be described with reference to FIGS. 4 through 6C.

[0066] FIG. 4 is a view illustrating a method of sensing volume information about a whole area of an object that is to be sensed, according to an exemplary embodiment. If it is determined that a distance between the object and the light-emitting device 210 exceeds a second distance, the controller 240 may drive the light-emitting device 210 and the image sensor 230. Also, the image sensor 230 may detect reflected light that is emitted from the light-emitting device 210 and reflected from the object. The controller 240 may acquire depth data by using the reflected light detected by the image sensor 230. The depth data may be data that expresses the distance between the object and the light-emitting device 210 in a pixel type resolution size. The depth data may be realized as one of 8 bit, 16 bit, and 32 bit types.

[0067] The controller 240 may acquire volume information about a whole area (e.g., a whole body of a user) of the object by using the depth data. The volume information about the whole area of the object may include at least one of a whole body image, weight information, body circumference information, and a BMI value of the object.

[0068] The controller 240 may control the transparent display 250 to display at least one of the whole body image, the weight information, the body circumference information, and the BMI value of the object and control the communicator 260 to transmit at least one of the whole image, the weight information, the body circum-

ference information, and the BMI value to an external display apparatus.

[0069] FIG. 5 is a view illustrating a method of sensing volume information about an area of an object that is to be sensed, according to an exemplary embodiment. If it is determined that a distance between the object and a light-emitting device 210 exceeds a first distance and is within a second distance, a controller 240 may sequentially drive the light-emitting device 210 and a light-receiving device 220 that is paired with the light-emitting device 210. The light-receiving device 220 may detect reflected light that is emitted from the light-emitting device 210 and reflected from the object. The controller 240 may acquire depth data by using the reflected light detected by the light-receiving device 220. The depth data may be data that expresses the distance between the object and the light-emitting device 210 in a pixel type resolution size and may be realized as one of 8 bit, 16 bit, and 32 bit types.

[0070] The controller 240 may acquire volume information about an area of the object (e.g., a whole body of a user) by using the depth data. The volume information about the area of the object may include at least one of an image of an area of a body of the object and body circumference information about the area.

[0071] The controller 240 may control the transparent display 250 to display at least one of the image of the area of the body of the object and the body circumference information of the area and control the communicator 260 to transmit at least one of the image of the area of the body of the object and the body circumference information of the area.

[0072] FIGS. 6A through 6C are views illustrating a method of acquiring blood flow information of an object that is to be sensed, according to an exemplary embodiment. If it is determined that a distance between the object and a light-emitting device 210 is within a first distance, the controller 240 may sequentially drive the light-emitting device 210 and a light-receiving device 220 that is paired with the light-emitting device 210. The light-receiving device 220 may detect reflected light that is emitted from the light-emitting device 210 and reflected from the object (e.g., a finger or the like). The controller 240 may acquire blood flow data by using the reflected light detected by the light-receiving device 220.

[0073] In more detail, if the light-emitting device 210 may emit a light signal to a finger of a human, blood, bones, and tissues of the finger absorb light, and a portion of the light may be reflected to be detected by the light-receiving device 22. In particular, an absorption degree of the light is proportional to the skin, tissues, and amount of blood positioned within the path of the light. However, as shown in FIG. 6B, the absorption degree of the light is not changed by other components except a blood flow change caused by a heart rate.

[0074] Therefore, as shown in FIG. 6C, the light-receiving device 220 may receive the reflected light from

which an amount corresponding to a light amount absorbed into the finger is subtracted. Therefore, a light amount change of the reflected light may also indicate the blood flow change, and thus the light-receiving device 220 may measure an amount of the reflected light to detect a blood volume change synchronizing with the heart rate. In particular, component AC shown in FIG. 6C is generally referred to as a Photo PlethysmoGraph (PPG).

[0075] Blood flow data may be realized as one of 8 bit, 16 bit, and 32 bit types and may be constituted along with or separately from depth data.

[0076] The controller 240 may acquire blood flow information of the object by using the blood flow data. Blood flow information may include heart rate information and artery hardening information.

[0077] The controller 240 may control the transparent display 250 to display at least one of the heart rate information and the artery hardening information and control the communicator 260 to transmit at least one of the heart rate information and the artery hardening information to the external display apparatus. The heart rate information may be displayed as a numerical value, but this is only exemplary. Therefore, the heart rate information may be displayed in a graph form.

[0078] The apparatus 200 according to the present exemplary embodiment may be installed in a shower booth, and at least one side of the shower booth may be realized as the transparent display 250. In detail, as shown in FIG. 7A, the apparatus 200 may be installed in three sides of the shower booth, and the three sides of the shower booth may be realized as the transparent display 250.

[0079] Here, the apparatus 200 installed on at least one side of the shower booth may acquire body information (a whole body image, a BMI value, heart rate information, artery hardening information, etc.) of a user according to a method as described above and display the body information on a side of the shower booth as shown in FIG. 7B. The apparatus 200 may display contents, which are received from an external source, on another side of the shower booth and display an image content stored in the storage unit 270.

[0080] In the above-described exemplary embodiment, the controller 240 selectively drives one of the light-receiving device 220 and the image sensor 230 according to the distance between the object and the light-emitting device 210 to sense one of volume information and blood flow information. However, this is only an exemplary embodiment, and the controller 240 may sense one of the volume information and the blood flow information according to another method.

[0081] In detail, the controller 240 may selectively operate in one of a first operation mode for sensing blood flow information of the object by using the light-receiving device 220, a second operation mode for sensing volume information of the object by using the light-receiving device 220, and a third operation mode for sensing the volume information of the object by using the image sensor 230. The first, second, and third operation modes may

be set according to a user input. The user input may be input through various types of input devices such as a touch screen, a remote controller, a pointing device, a voice input device, a motion input device, etc.

[0082] In detail, if the first operation mode is set by the user input, the controller 240 may sequentially drive a plurality of light-emitting devices 210 to emit light signals and sequentially drive a plurality of light-receiving devices 220 to emit reflected light reflected from the object in order to sense blood flow information of the object. Also, if the second operation mode is set by the user input, the controller 240 may sequentially drive the plurality of light-emitting devices 210 to emit the light signals and sequentially drive the plurality of light-receiving devices 220 to detect the reflected light reflected from the object in order to sense volume information about an area of the object. If the third operation mode is set by the input unit, the controller 240 may drive the light-emitting device 210 to emit a light signal and drive the image sensor to detect reflected light reflected from the object in order to sense volume information about a whole area of the object. If the third operation mode is set, and a distance between the object and the light-emitting device 210 is within a preset second distance, the controller 240 may control the transparent display 250 to determine that a saturation of the reflected light is higher than or equal to a preset value in order to display a notification message about that the volume information about the whole area of the object may not be sensed. Also, the controller 240 may automatically convert an operation mode into the second operation mode to sense the volume information about the area of the object.

[0083] In the above-described exemplary embodiment, the transparent display 250 is used to display various types of body information, but this is only exemplary. The transparent display 250 may be realized as other types of displays (e.g., a cathode ray tube (CRT), a liquid crystal display (LCD), an organic light-emitting diode (OLED), etc.)

[0084] The user may simultaneously acquire blood flow information and volume information of the user by using the apparatus 200 for sensing the body information as described above and thus systematically manage health.

[0085] Methods of sensing body information according to exemplary embodiments concept will now be described with reference to FIGS. 8 and 9. FIG. 8 is a flowchart of a method of sensing body information through the apparatus 200 for sensing body information, according to an exemplary embodiment.

[0086] Referring to FIG. 8, in operation S810, the apparatus 200 determines a distance between an object that is to be sensed and the light-emitting device 210. The apparatus 200 may drive the image sensor 230 to determine the distance between the object and the light-emitting device 210 by using a saturation of reflected light reflected from the object. The apparatus 200 may also determine the distance between the object and the light-

emitting device 210 by using a user touch input into the transparent display 250.

[0087] In operation S820, the apparatus 200 drives at least one of the light-receiving device 220 and the image sensor 230 to detect the reflected light. In detail, if it is determined that the distance between the object and the light-emitting device 210 is within a second distance, the apparatus 200 may detect the reflected light by using the light-receiving device 220. If it is determined that the distance between the object and the light-emitting device 210 exceeds the second distance, the apparatus 200 may detect the reflected light by using the image sensor 230.

[0088] In operation S830, the apparatus 200 senses volume information or blood flow information by using the acquired reflected light. In detail, if it is determined that the distance between the object and the light-emitting device 210 is within a first distance, the apparatus 200 may sense the blood flow information by using the reflected light detected by the light-receiving device 220. Also, if it is determined that the distance between the object and the light-emitting device 210 exceeds the first distance and is within the second distance, the apparatus 200 may sense volume information about an area of the object by using the reflected light detected by the light-receiving device 220. If it is determined that the distance between the object and the light-emitting device 210 exceeds the second distance, the apparatus 200 may sense volume information about a whole area of the object by using the reflected light detected by the image sensor 230.

[0089] FIG. 9 is a flowchart of a method of sensing body information through the apparatus 200 for sensing body information, according to another exemplary embodiment.

[0090] Referring to FIG. 9, in operation S910, the apparatus 200 determines an operation mode. The operation mode of the apparatus 200 may be set by a user input.

[0091] If it is determined in operation S920 that the operation mode of the apparatus 200 is a first operation mode, the apparatus 200 blood flow information of an object that is to be sensed, by using the light-emitting device 210 and the light-receiving device 220 in operation S930.

[0092] If it is determined in operation S940 that the operation mode of the apparatus 200 is a second operation mode, the apparatus 200 senses volume information of the object by using the light-emitting device 210 and the light-receiving device 220 in operation S950. The apparatus 200 may sense volume information about an area of the object by using the light-emitting device 210 and the light-receiving device 220.

[0093] If it is determined in operations S920 and S940 that the operation mode of the apparatus 200 is not the first operation mode and the second operation mode, the apparatus 200 determines that the operation mode is a third operation mode in operation S960 and senses the

volume information of the object by using light-emitting device 210 and the image sensor 230 in operation S970. The apparatus 200 may sense volume information about a whole area of the object by using the light-emitting device 210 and the image sensor 230.

[0094] As described with reference to FIGS. 8 and 9, one of the light-receiving device 220 and the image sensor 230 may be selectively driven to acquire reflected light in order to simultaneously acquire volume information and blood flow information of the object.

[0095] In the above-described exemplary embodiment, the distance between the object and the light-emitting device 210 is determined by using the saturation of the reflected light detected by the image sensor 230. However, this is only exemplary: the apparatus 200 may determine the distance between the object and the light-emitting device 210 by using other methods.

[0096] In detail, as shown in FIG. 10, the apparatus 200 for sensing the body information may include a light-emitting device 1010, a light-receiving device 1020, an image sensor 1030, a controller 1040, and a distance information acquirer 1050. The descriptions of the light-emitting device 1010, the light-receiving device 1020, and the image sensor 1030 are the same as those of the light-emitting device 110, the light-receiving device 120, and the image sensor 130 of FIG. 1, and thus their repeated descriptions are omitted herein.

[0097] The distance information acquirer 1050 acquires distance information between an object that is to be sensed and the light-emitting device 1010. In detail, the distance information acquirer 1050 may be realized as a sensor for acquiring the distance information between the object and the light-emitting device 1010, i.e., as an ultrasonic sensor or the like. According to another exemplary embodiment, the distance information acquirer 1050 may acquire the distance information between the object and the light-emitting device 1010 through a direct input of a user.

[0098] The controller 1040 may selectively drive at least one of the light-receiving device 1020 and the image sensor 1030 according to the distance between the object and the light-emitting device 1010 to acquire a reflected light signal, wherein the distance is acquired by the distance information acquirer 1050. The controller 1040 may also sense volume information or blood flow information of the object by using the reflected light signal.

[0099] According to an exemplary embodiment, an apparatus 1100 for sensing body information may not include an additional display unit but may display body information by using an external display apparatus 1150 as shown in FIG. 11.

[0100] In detail, as shown in FIGS. 2A through 6C, the apparatus 1100 may sense volume information or blood flow information. The apparatus 1100 may transmit the sensed volume information or blood flow information to the external display apparatus 1155 by using a communicator using a wired communication method or a wire-

less communication method. The external display apparatus 1150 may provide various types of user interfaces (UIs) by using the volume information or the blood flow information. For example, as shown in FIG. 12, the external display apparatus 1150 may display a body image UI 1210 of an object that is to be sensed and a body information UI 1220 including various types of body information.

[0101] According to another exemplary embodiment, the apparatus 100 for sensing the body information may sense a motion of a user and control an external apparatus by using a body image of volume information. In detail, a home control system 1300 may include a body information sensing apparatus 200, a TV 1310, an air conditioner 1320, a vacuum cleaner 1330, an illumination lamp 1340, a front door 1350, and a washing machine 1360. The home control system 1300 may include other types of devices besides devices used in a home as shown in FIG. 13.

[0102] The body information sensing apparatus 200 may acquire a body image of an area of the object by using the light-emitting device 210 and the light-receiving device 220 and sense a user motion by using the body image. The body information sensing apparatus 200 may determine a control command by using the sensed user motion and transmit the control command corresponding to the user motion to a device that is to be controlled.

[0103] As described above, the body information sensing apparatus 200 may sense the user motion by using the light-emitting device 210 and the light-receiving device 220 to control various types of devices that are to be controlled. For example, the body information sensing apparatus 200 may perform various types of controls, such as controls of power, a volume, a channel, etc. of the TV 1310, by using the sensed user motion. The body information sensing apparatus 200 may perform various types of controls such as controls of wind, wind strength, a wind direction, etc. of the air conditioner 1320 by using the sensed user motion. The body information sensing apparatus 200 may perform various types of controls, such as controls of power, inhaling strength, etc. of the vacuum cleaner 1330, by using the sensed user motion. The body information sensing apparatus 200 may also perform various types of controls, such as controls of power, brightness, etc. of the illumination lamp 1340, by using the sensed user motion. The body information sensing apparatus 200 may perform a control for opening and closing the front door 1350 by using the sensed user motion. The body information sensing apparatus 200 may perform various types of controls, such as power, an operation mode, etc. of the washing machine 1360, by using the sensed user motion. External devices as described above are only exemplary, and other types of external devices may be controlled by using a user motion.

[0104] FIG. 14 is a flowchart of a method of sensing a user motion by using the body information sensing apparatus 200 to control an external device, according to

an exemplary embodiment.

[0105] Referring to FIG. 14, in operation S1410, the body information sensing apparatus 200 emits a light signal through the light-emitting device 210.

[0106] In operation S1420, the body information sensing apparatus 200 acquires reflected light reflected from a user by using one of the light-receiving device 220 and the image sensor 230. In particular, the body information sensing apparatus 200 may acquire the reflected light reflected from an object that is to be sensed, by using the light-receiving device 220 in order to sense a motion of an area of a body of the user.

[0107] In operation S1430, the body information sensing apparatus 200 acquires joint information of the user.

In detail, the body information sensing apparatus 200 may acquire a body image by using the acquired reflected light. The body information sensing apparatus 200 may acquire a joint area of the user by using the acquired body image.

[0108] In operation S1440, the body information sensing apparatus 200 recognizes a user motion by using the joint information. In detail, the body information sensing apparatus 200 may connect a plurality of joint areas to one another to acquire line. The body information sensing apparatus 200 may recognize the user motion by using a movement direction of the light and an increase or a decrease in a length of the line.

[0109] In operation S1450, the body information sensing apparatus 200 transmits a control command corresponding to the recognized user motion to an external device. In detail, the body information sensing apparatus 200 may generate a control command corresponding to an external device that is to be controlled, by using user motion information and transmit the generated control command to the external device.

[0110] A method of transmitting body information sensed by a body information sensing apparatus to an external service to provide a body management service to a user according to an exemplary embodiment will now be described with reference to FIGS. 15 and 16.

[0111] As shown in FIG. 15, a system for providing a body management service includes a body information sensing apparatus 200 and a server 1500. In detail, the body information sensing apparatus 200 may acquire various types of body information such as blood flow information, volume information, etc. according to methods as described above and transmit the acquired body information to the server 1500.

[0112] The server 1500 may store the received body information in a database (DB) and analyze the body information. If an unusual symptom is detected from a body of a user according to the analysis result of the body information, the server 1500 may transmit the analysis result including information about the unusual symptom to the body information sensing apparatus 200. The body information sensing apparatus 200 may display the analysis result, and the user may check the analysis result to check a health status of the user. The server 1500 may

transmit the analysis result of the body information to a terminal of a hospital that the user frequently goes to.

[0113] FIG. 16 is a sequence chart illustrating a method of transmitting body information sensed by the body information sensing apparatus 200 to an external server to provide a body management service to a user, according to an exemplary embodiment.

[0114] In operation S1610, the body information sensing apparatus 200 acquires body information. In detail, the body information sensing apparatus 200 may selectively drive at least one of the light-receiving device 220 and the image sensor 230 according to a distance between an object that is to be sensed and the light-emitting device to acquire a reflected light signal and acquire volume information or blood flow information of the object by using the reflected light signal.

[0115] In operation S1620, the body information sensing apparatus 200 transmits the acquired body information to the server 1500.

[0116] In operation S1630, the server 1500 analyzes the received body information. The server 1500 may analyze an unusual symptom of a body of a user by using the body information. In detail, the server 1500 may analyze unusual symptoms of heart and blood vessels of the user by using the blood flow information and analyze an unusual symptom of a sudden body change of the user by using depth information.

[0117] In operations S1640 and S1650, the server 1500 transmits the analysis result to the body information sensing apparatus 200 and a hospital terminal 1600. The server 1500 may periodically transmit the analysis result to the body information sensing apparatus 200 and the hospital terminal 1600, but this is only exemplary. However, if an unusual symptom is sensed, the server 1500 may transmit the analysis result to the body information sensing apparatus 200 and the hospital terminal 1600.

[0118] In operation S1660, the body information sensing apparatus 200 displays the received analysis result.

[0119] As described above, the server 1500 may analyze body information and provide the analysis result to a user. Therefore, the user may be provided with a systematic and specialized health management service.

[0120] A method of sensing body information according to various exemplary embodiments as described above may be embodied as a program and then provided to a display apparatus or an input device. In particular, a program including a method of controlling the display apparatus may be stored and provided on a non-transitory computer-readable medium.

[0121] The non-transitory computer-readable medium refers to a medium which does not store data for a short time such as a register, a cache memory, a memory, or the like but semi-permanently stores data and is readable by a device. In detail, the above-described various applications or programs may be stored and provided on a non-transitory computer readable medium such as a CD, a DVD, a hard disk, a blue-ray disk, a universal serial bus (USB), a memory card, a ROM, or the like.

[0122] Although a few preferred embodiments have been shown and described, it will be appreciated by those skilled in the art that various changes and modifications might be made without departing from the scope of the invention, as defined in the appended claims.

[0123] Attention is directed to all papers and documents which are filed concurrently with or previous to this specification in connection with this application and which are open to public inspection with this specification.

Claims

1. An apparatus (200) for sensing body information, the apparatus (200) comprising:

a light-emitting device (210) configured to emit light toward an object;
 a light-receiving device (220) configured to detect reflected light reflected from the object;
 an image sensor (230) configured to detect the reflected light;
 and a controller (240) configured to:

determine a distance between the object and the light-emitting device (210);
 selectively drive at least one of the light-receiving device (220) and the image sensor (230) according to a distance between the object and the light-emitting device (210);
characterized in that the controller is further configured to determine at least one of body volume information of the object and blood flow information of the object based on the reflected light;
 wherein, when the distance between the object and the light-emitting device (210) is within a first distance, the controller (240) is configured to determine the blood flow information, and when the distance between the object and the light-emitting device (210) exceeds the first distance, the controller is configured to determine the body volume information of the object.

2. The apparatus of claim 1 wherein, when the distance between the object and the light-emitting device (210) is within the first distance, the controller (240) is configured to determine the blood flow information using the light-receiving device (220), and when the distance between the object and the light-emitting device (210) exceeds the first distance, the controller (240) is configured to determine the body volume information using one of the light-receiving device (220) and the image sensor (230).
3. The apparatus of claim 2 wherein, when the distance between the object and the light-emitting device

- (210) exceeds the first distance and is within a second distance, the controller (240) is configured to determine body volume information about an area of the object, and when the distance between the object and the light-emitting device (210) exceeds the first distance and the second distance, the controller (240) is configured to determine the body volume information about a whole area of the object using the image sensor (230).
4. The apparatus of any one of claims 1 through 3, wherein the controller (240) is configured to activate the image sensor (230) to sense a saturation of the reflected light and the controller (240) is configured to selectively select at least one of the light-receiving device (220) and the image sensor (230) according to an amount of the saturation, wherein the saturation varies according to the distance between the object and the light-emitting device (210).
5. The apparatus (200) of any preceding claim, wherein the light-emitting device (210), the light-receiving device (220), and the image sensor (230) are integrated into a single sensor module, wherein the image sensor (230) is disposed in a center of the sensor module, the light-emitting device (210) comprises a plurality of light-emitting devices (210-1, 210-2, 210-3, 210-4) disposed in a peripheral area of the image sensor, and the light-receiving device (220) comprises a plurality of light-receiving devices (220-1, 220-2, 220-3, 220-4) disposed in conjunction with the plurality of light-emitting devices (210-1, 210-2, 210-3, 210-4), such that each of the plurality of light-receiving devices (220-1, 220-2, 220-3, 220-4) is paired with one of the plurality of light-emitting devices (210-1, 210-2, 210-3, 210-4).
6. The apparatus (200) of claim 5, further comprising:
a transparent display (250) configured to cover the sensor module, configured to transmit the light emitted from the light-emitting device (210) and the reflected light reflected from the object, wherein the controller (240) is configured to control the transparent display (250) to display at least one of the blood flow information and the body volume information.
7. The apparatus (200) of claim 6, wherein the blood flow information comprises heart rate information and artery hardening information, and the body volume information comprises at least one of a body image, weight information, body circumference information, and a body mass index, BMI, value of the object, wherein the controller (240) is configured to control the transparent display (250) to display at least one of the heart rate information, the artery hardening information, and the body image, the weight information, the body circumference information, and the BMI value of the object.
8. The apparatus (200) of claim 6 or claim 7, wherein, in response to a user touching the transparent display (250), the controller (240) is configured to determine that the distance between the object and the light-emitting device (210) is within the first distance.
9. The apparatus of any one of claims 1 through 8, further comprising:
a communicator (260) configured to communicate with an external display apparatus (1150), wherein the controller (240) is configured to control the communicator (260) to transmit at least one of the body volume information and the blood flow information to the external display apparatus (1150).
10. A method of sensing body information, the method comprising:
determining, by a controller, a distance between an object and a light-emitting device (210) that emits light toward the object (S810);
selecting, by the controller, at least one of a light-receiving device (220) and an image sensor (230) to detect reflected light reflected from the object according to the distance between the object and the light-emitting device (210);
acquiring the reflected light using the selected at least one of the light-receiving device (220) and the image sensor (230) (S820);
characterized in that the method further comprises:
determining, by the controller at least one of body volume information and blood flow information of the object by using the reflected light (S830);
when the distance between the object and the light-emitting device (210) is within a first distance, determining, by the controller, the blood flow information of the object; and
when the distance between the object and the light-emitting device (210) exceeds the first distance, determining, by the controller, the body volume information of the object.
11. The method of claim 10, further comprising:
when the distance between the object and the light-emitting device (210) is within the first distance, determining the blood flow information is by using the light-receiving device (220), and

when the distance between the object and the light-emitting device (210) exceeds the first distance, determining the body volume information by using one of the light-receiving device (220) and the image sensor (230).

5

12. The method of claim 11, further comprising:

when the distance between the object and the light-emitting device (210) exceeds the first distance and is within a second distance, determining the body volume information about an area of the object by using the light-receiving device (220), and

10

when the distance between the object and the light-emitting device (210) exceeds the first distance and the second distance, determining the body volume information about a whole area of the object by using the image sensor (230).

15

20

13. The method of any one of claims 10 through 12, further comprising:

activating the image sensor (230), and thereby determining a saturation of the reflected light signal, and determining the distance between the object and the light-emitting device (210) according to an amount of the saturation.

25

30

Patentansprüche

1. Einrichtung (200) zum Erfassen von Körperinformationen, wobei die Einrichtung (200) Folgendes umfasst:

35

eine Lichtemissionsvorrichtung (210), die zum Emittieren von Licht zu einem Objekt hin konfiguriert ist;
eine Lichtempfangsvorrichtung (220), die zum Detektieren von reflektiertem Licht konfiguriert ist, das von dem Objekt reflektiert wird;
einen Bildsensor (230), der zum Detektieren des reflektierten Lichts konfiguriert ist;
und eine Steuerung (240), die zu Folgendem konfiguriert ist:

40

45

55

Bestimmen einer Entfernung zwischen dem Objekt und der Lichtemissionsvorrichtung (210);
selektives Ansteuern der Lichtempfangsvorrichtung (220) und/oder des Bildsensors (230) gemäß einer Entfernung zwischen dem Objekt und der Lichtemissionsvorrichtung (210);
dadurch gekennzeichnet, dass die Steuerung ferner zu Folgendem konfiguriert ist:

50

55

Bestimmen von Körpervolumeninformationen des Objekts und/oder Blutflussinformationen des Objekts basierend auf dem reflektierten Licht; wobei, wenn die Entfernung zwischen dem Objekt und der Lichtemissionsvorrichtung (210) innerhalb einer ersten Entfernung liegt, die Steuerung (240) zum Bestimmen der Blutflussinformationen konfiguriert ist und, wenn die Entfernung zwischen dem Objekt und der Lichtemissionsvorrichtung (210) die erste Entfernung überschreitet, die Steuerung zum Bestimmen der Körpervolumeninformationen des Objekts konfiguriert ist.

2. Einrichtung nach Anspruch 1, wobei, wenn die Entfernung zwischen dem Objekt und der Lichtemissionsvorrichtung (210) innerhalb der ersten Entfernung liegt, die Steuerung (240) zum Bestimmen der Blutflussinformationen unter Verwendung der Lichtempfangsvorrichtung (220) konfiguriert ist und, wenn die Entfernung zwischen dem Objekt und der Lichtemissionsvorrichtung (210) die erste Entfernung überschreitet, die Steuerung (240) zum Bestimmen der Körpervolumeninformationen unter Verwendung der Lichtempfangsvorrichtung (220) oder des Bildsensors (230) konfiguriert ist.

3. Einrichtung nach Anspruch 2, wobei, wenn die Entfernung zwischen dem Objekt und der Lichtemissionsvorrichtung (210) die erste Entfernung überschreitet und innerhalb einer zweiten Entfernung liegt, die Steuerung (240) zum Bestimmen von Körpervolumeninformationen über einen Bereich des Objekts konfiguriert ist und, wenn die Entfernung zwischen dem Objekt und der Lichtemissionsvorrichtung (210) die erste Entfernung und die zweite Entfernung überschreitet, die Steuerung (240) zum Bestimmen der Körpervolumeninformationen über einen gesamten Bereich des Objekts unter Verwendung des Bildsensors (230) konfiguriert ist.

4. Einrichtung nach einem der Ansprüche 1 bis 3, wobei die Steuerung (240) zum Aktivieren des Bildsensors (230) konfiguriert ist, um eine Sättigung des reflektierten Lichts zu erfassen, und die Steuerung (240) zum selektiven Auswählen der Lichtempfangsvorrichtung (220) und/oder des Bildsensors (230) gemäß einer Sättigungsmenge konfiguriert ist, wobei die Sättigung gemäß der Entfernung zwischen dem Objekt und der Lichtemissionsvorrichtung (210) variiert.

5. Einrichtung (200) nach einem vorhergehenden Anspruch, wobei die Lichtemissionsvorrichtung (210), die Lichtempfangsvorrichtung (220) und der Bildsen-

- sor (230) in ein einziges Sensormodul integriert sind, wobei der Bildsensor (230) in einem Zentrum des Sensormoduls angeordnet ist, die Lichtemissionsvorrichtung (210) mehrere Lichtemissionsvorrichtungen (210-1, 210-2, 210-3, 210-4) umfasst, die in einem Peripheriebereich des Bildsensors angeordnet sind, und die Lichtempfangsvorrichtung (220) mehrere Lichtempfangsvorrichtungen (220-1, 220-2, 220-3, 220-4) umfasst, die in Verbindung mit den mehreren Lichtemissionsvorrichtungen (210-1, 210-2, 210-3, 210-4) angeordnet sind, so dass jede der mehreren Lichtempfangsvorrichtungen (220-1, 220-2, 220-3, 220-4) mit einer der mehreren Lichtemissionsvorrichtungen (210-1, 210-2, 210-3, 210-4) gepaart ist.
6. Einrichtung (200) nach Anspruch 5, die ferner Folgendes umfasst:
- eine transparente Anzeige (250), die zum Bedecken des Sensormoduls konfiguriert ist, zum Transmittieren des von der Lichtemissionsvorrichtung (210) emittierten Lichts und des reflektierten Lichts, das von dem Objekt reflektiert wird, konfiguriert ist, wobei die Steuerung (240) zum Steuern der transparenten Anzeige (250) dazu konfiguriert ist, die Blutflussinformationen und/oder die Körpervolumeninformationen anzuzeigen.
7. Einrichtung (200) nach Anspruch 6, wobei die Blutflussinformationen Herzfrequenzinformationen und Arterienverhärtungsinformationen umfassen und wobei die Körpervolumeninformationen ein Körperbild, Gewichtsinformationen, Körperumfangsinformationen und/oder den BMI-Wert des Objekts umfassen, wobei die Steuerung (240) zum Steuern der transparenten Anzeige (250) zum Anzeigen der Herzfrequenzinformationen, der Arterienverhärtungsinformationen und/oder des Körperbildes, der Gewichtsinformationen, der Körperumfangsinformationen und/oder des BMI-Wertes des Objekts konfiguriert ist.
8. Einrichtung (200) nach Anspruch 6 oder Anspruch 7, wobei die Steuerung (240) als Reaktion darauf, dass ein Benutzer die transparente Anzeige (250) berührt, zum Bestimmen konfiguriert ist, dass die Entfernung zwischen dem Objekt und der Lichtemissionsvorrichtung (210) innerhalb der ersten Entfernung liegt.
9. Einrichtung nach einem der Ansprüche 1 bis 8, die ferner Folgendes umfasst:
- einen Kommunikator (260), der zum Kommunizieren mit einer externen Anzeigeeinrichtung (1150) konfiguriert ist,
- wobei die Steuerung (240) zum Steuern des Kommunikators (260) dazu konfiguriert ist, die Körpervolumeninformationen und/oder die Blutflussinformationen an die externe Anzeigeeinrichtung (1150) zu übertragen.
10. Verfahren zum Erfassen von Körperinformationen, wobei das Verfahren Folgendes umfasst:
- Bestimmen, durch eine Steuerung, einer Entfernung zwischen einem Objekt und einer Lichtemissionsvorrichtung (210), die Licht zu dem Objekt hin emittiert (S810);
Auswählen, durch die Steuerung, einer Lichtempfangsvorrichtung (220) und/oder eines Bildsensors (230), um reflektiertes Licht, das von dem Objekt reflektiert wird, zu detektieren, gemäß der Entfernung zwischen dem Objekt und der Lichtemissionsvorrichtung (210);
Erfassen des reflektierten Lichts unter Verwendung des/der ausgewählten der Lichtempfangsvorrichtung (220) und/oder des Bildsensors (230) (S820);
dadurch gekennzeichnet, dass das Verfahren ferner Folgendes umfasst:
- Bestimmen, durch die Steuerung, von Körpervolumeninformationen und/oder Blutflussinformationen des Objekts durch Verwenden des reflektierten Lichts (S830);
wenn die Entfernung zwischen dem Objekt und der Lichtemissionsvorrichtung (210) innerhalb einer ersten Entfernung liegt, Bestimmen, durch die Steuerung, der Blutflussinformationen des Objekts; und
wenn die Entfernung zwischen dem Objekt und der Lichtemissionsvorrichtung (210) die erste Entfernung überschreitet, Bestimmen, durch die Steuerung, der Körpervolumeninformationen des Objekts.
11. Verfahren nach Anspruch 10, das ferner Folgendes umfasst:
- wenn die Entfernung zwischen dem Objekt und der Lichtemissionsvorrichtung (210) innerhalb der ersten Entfernung liegt, Bestimmen der Blutflussinformationen durch Verwenden der Lichtempfangsvorrichtung (220), und
wenn die Entfernung zwischen dem Objekt und der Lichtemissionsvorrichtung (210) die erste Entfernung überschreitet, Bestimmen der Körpervolumeninformationen durch Verwenden der Lichtempfangsvorrichtung (220) oder des Bildsensors (230).
12. Verfahren nach Anspruch 11, das ferner Folgendes umfasst:

wenn die Entfernung zwischen dem Objekt und der Lichtemissionsvorrichtung (210) die erste Entfernung überschreitet und innerhalb einer zweiten Entfernung liegt, Bestimmen der Körpervolumeninformationen über einen Bereich des Objekts durch Verwenden der Lichtempfangsvorrichtung (220), und

wenn die Entfernung zwischen dem Objekt und der Lichtemissionsvorrichtung (210) die erste Entfernung und die zweite Entfernung überschreitet, Bestimmen der Körpervolumeninformationen über einen gesamten Bereich des Objekts durch Verwenden des Bildsensors (230).

13. Verfahren nach einem der Ansprüche 10 bis 12, das ferner Folgendes umfasst:

Aktivieren des Bildsensors (230) und dadurch Bestimmen einer Sättigung des reflektierten Lichtsignals, und
Bestimmen der Entfernung zwischen dem Objekt und der Lichtemissionsvorrichtung (210) gemäß einer Sättigungsmenge.

Revendications

1. Appareil (200) destiné à détecter des informations corporelles, l'appareil (200) comprenant :

un dispositif émetteur de lumière (210) configuré pour émettre de la lumière vers un objet ;
un dispositif récepteur de lumière (220) configuré pour détecter de la lumière réfléchie, réfléchie depuis l'objet ;
un capteur d'images (230) configuré pour détecter la lumière réfléchie ;
et un contrôleur (240) configuré pour :

déterminer une distance entre l'objet et le dispositif émetteur de lumière (210) ;
commander sélectivement le dispositif récepteur de lumière (220) et/ou le capteur d'images (230) en fonction d'une distance entre l'objet et le dispositif émetteur de lumière (210) ;

caractérisé en ce que le contrôleur est également configuré pour déterminer des informations de volume corporel de l'objet et/ou des informations de flux sanguin de l'objet sur la base de la lumière réfléchie ;

dans lequel, quand la distance entre l'objet et le dispositif émetteur de lumière (210) est inférieure ou égale à une première distance, le contrôleur (240) est configuré pour déterminer les informations de flux sanguin, et quand la distance entre l'objet et le dispositif

émetteur de lumière (210) dépasse la première distance, le contrôleur est configuré pour déterminer les informations de volume corporel de l'objet.

2. Appareil de la revendication 1 dans lequel, quand la distance entre l'objet et le dispositif émetteur de lumière (210) est inférieure ou égale à la première distance, le contrôleur (240) est configuré pour déterminer les informations de flux sanguin en utilisant le dispositif récepteur de lumière (220), et quand la distance entre l'objet et le dispositif émetteur de lumière (210) dépasse la première distance, le contrôleur (240) est configuré pour déterminer les informations de volume corporel en utilisant soit le dispositif récepteur de lumière (220), soit le capteur d'images (230).

3. Appareil de la revendication 2 dans lequel, quand la distance entre l'objet et le dispositif émetteur de lumière (210) dépasse la première distance et est inférieure ou égale à une deuxième distance, le contrôleur (240) est configuré pour déterminer des informations de volume corporel sur une zone de l'objet, et quand la distance entre l'objet et le dispositif émetteur de lumière (210) dépasse la première distance et la deuxième distance, le contrôleur (240) est configuré pour déterminer les informations de volume corporel sur une zone entière de l'objet en utilisant le capteur d'images (230).

4. Appareil de l'une quelconque des revendications 1 à 3, dans lequel le contrôleur (240) est configuré pour activer le capteur d'images (230) pour détecter une saturation de la lumière réfléchie et le contrôleur (240) est configuré pour sélectionner sélectivement le dispositif récepteur de lumière (220) et/ou le capteur d'images (230) en fonction d'une quantité de la saturation, dans lequel la saturation varie en fonction de la distance entre l'objet et le dispositif émetteur de lumière (210).

5. Appareil (200) d'une quelconque revendication précédente, dans lequel le dispositif émetteur de lumière (210), le dispositif récepteur de lumière (220) et le capteur d'images (230) sont intégrés dans un seul module de capteur, dans lequel le capteur d'images (230) est disposé à un centre du module de capteur, le dispositif émetteur de lumière (210) comprend une pluralité de dispositifs émetteurs de lumière (210-1, 210-2, 210-3, 210-4) disposés dans une zone périphérique du capteur d'images, et le dispositif récepteur de lumière (220) comprend une pluralité de dispositifs récepteurs de lumière (220-1, 220-2, 220-3, 220-4) disposés conjointement avec la pluralité de dispositifs émetteurs de lumière (210-1, 210-2, 210-3, 210-4),

de telle sorte que chacun de la pluralité de dispositifs récepteurs de lumière (220-1, 220-2, 220-3, 220-4) est apparié avec un de la pluralité de dispositifs émetteurs de lumière (210-1, 210-2, 210-3, 210-4).

6. Appareil (200) de la revendication 5, comprenant en outre :

un écran transparent (250) configuré pour recouvrir le module de capteur, configuré pour transmettre la lumière émise depuis le dispositif émetteur de lumière (210) et la lumière réfléchie, réfléchie depuis l'objet, dans lequel le contrôleur (240) est configuré pour contrôler l'écran transparent (250) pour afficher les informations de flux sanguin et/ou les informations de volume corporel.

7. Appareil (200) de la revendication 6, dans lequel les informations de flux sanguin comprennent des informations de fréquence cardiaque et des informations de durcissement des artères, et les informations de volume corporel comprennent au moins un élément parmi une image corporelle, des informations de poids, des informations de circonférence corporelle, et une valeur d'indice de masse corporelle, IMC, de l'objet,

dans lequel le contrôleur (240) est configuré pour contrôler l'écran transparent (250) pour afficher au moins un élément parmi les informations de fréquence cardiaque, les informations de durcissement des artères, et l'image corporelle, les informations de poids, les informations de circonférence corporelle et la valeur d'IMC de l'objet.

8. Appareil (200) de la revendication 6 ou la revendication 7 dans lequel, en réponse au fait qu'un utilisateur touche l'écran transparent (250), le contrôleur (240) est configuré pour déterminer que la distance entre l'objet et le dispositif émetteur de lumière (210) est inférieure ou égale à la première distance.

9. Appareil de l'une quelconque des revendications 1 à 8, comprenant en outre :

un dispositif de communication (260) configuré pour communiquer avec un appareil d'affichage externe (1150), dans lequel le contrôleur (240) est configuré pour contrôler le dispositif de communication (260) pour transmettre les informations de volume corporel et/ou les informations de flux sanguin à l'appareil d'affichage externe (1150).

10. Procédé de détection d'informations corporelles, le procédé comprenant :

la détermination, par un contrôleur, d'une dis-

tance entre un objet et un dispositif émetteur de lumière (210) qui émet de la lumière vers l'objet (S810) ;

la sélection, par le contrôleur, d'un dispositif récepteur de lumière (220) et/ou d'un capteur d'images (230) pour détecter de la lumière réfléchie, réfléchie depuis l'objet, en fonction de la distance entre l'objet et le dispositif émetteur de lumière (210) ;

l'acquisition de la lumière réfléchie au moyen du dispositif récepteur de lumière (220) et/ou du capteur d'images (230) sélectionnés (S820) ; **caractérisé en ce que** le procédé comprend en outre :

la détermination, par le contrôleur, d'informations de volume corporel et/ou d'informations de flux sanguin de l'objet au moyen de la lumière réfléchie (S830) ;

quand la distance entre l'objet et le dispositif émetteur de lumière (210) est inférieure ou égale à une première distance, la détermination, par le contrôleur, des informations de flux sanguin de l'objet ; et

quand la distance entre l'objet et le dispositif émetteur de lumière (210) dépasse la première distance, la détermination, par le contrôleur, des informations de volume corporel de l'objet.

11. Procédé de la revendication 10, comprenant en outre :

quand la distance entre l'objet et le dispositif émetteur de lumière (210) est inférieure ou égale à la première distance, la détermination des informations de flux sanguin au moyen du dispositif récepteur de lumière (220), et quand la distance entre l'objet et le dispositif émetteur de lumière (210) dépasse la première distance, la détermination des informations de volume corporel au moyen soit du dispositif récepteur de lumière (220), soit du capteur d'images (230).

12. Procédé de la revendication 11, comprenant en outre :

quand la distance entre l'objet et le dispositif émetteur de lumière (210) dépasse la première distance et est inférieure ou égale à une deuxième distance, la détermination des informations de volume corporel sur une zone de l'objet au moyen du dispositif récepteur de lumière (220), et quand la distance entre l'objet et le dispositif émetteur de lumière (210) dépasse la première distance et la deuxième distance, la détermination

tion des informations de volume corporel sur une zone entière de l'objet au moyen du capteur d'images (230).

13. Procédé de l'une quelconque des revendications 10 à 12, comprenant en outre :

l'activation du capteur d'images (230), et ainsi la détermination d'une saturation du signal lumineux réfléchi, et la détermination de la distance entre l'objet et le dispositif émetteur de lumière (210) en fonction d'une quantité de la saturation.

5

10

15

20

25

30

35

40

45

50

55

FIG. 1

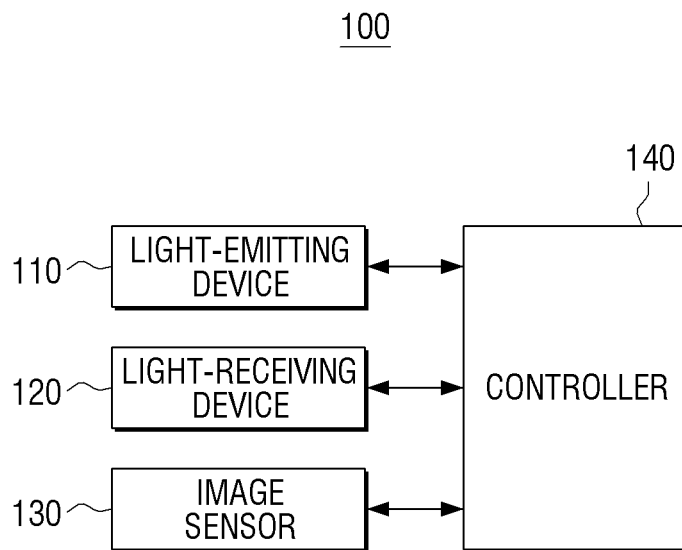

FIG. 2A

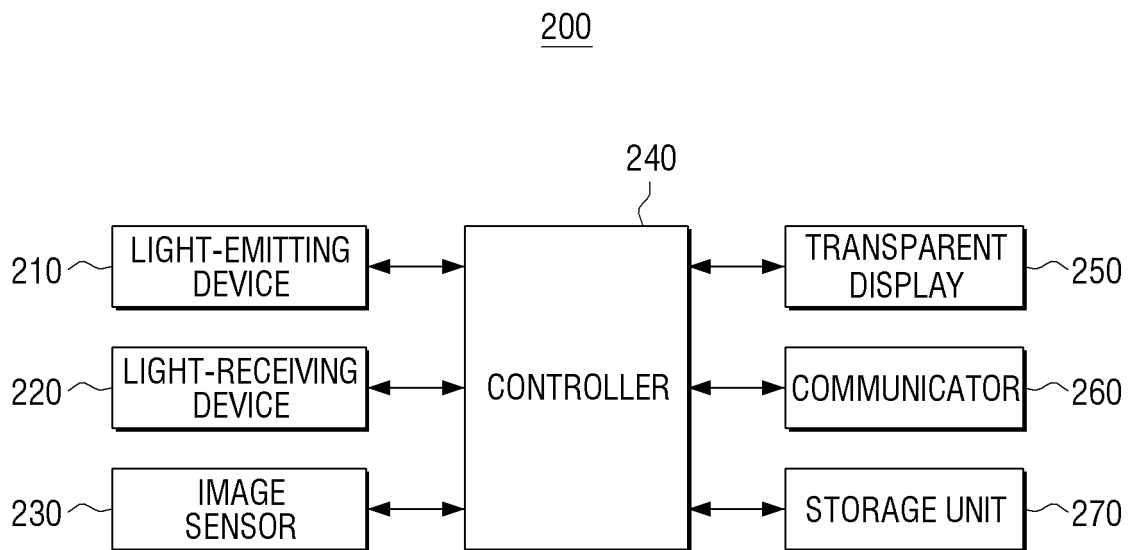

FIG. 2B

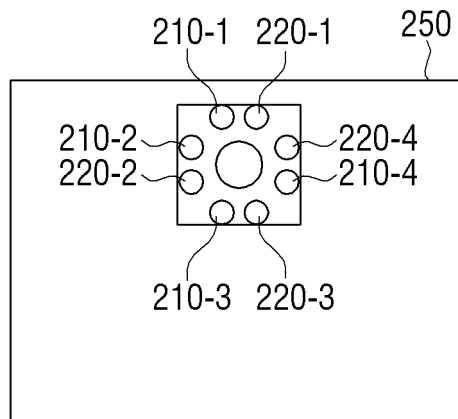

FIG. 2C

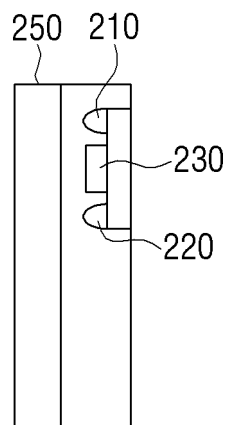

FIG. 3

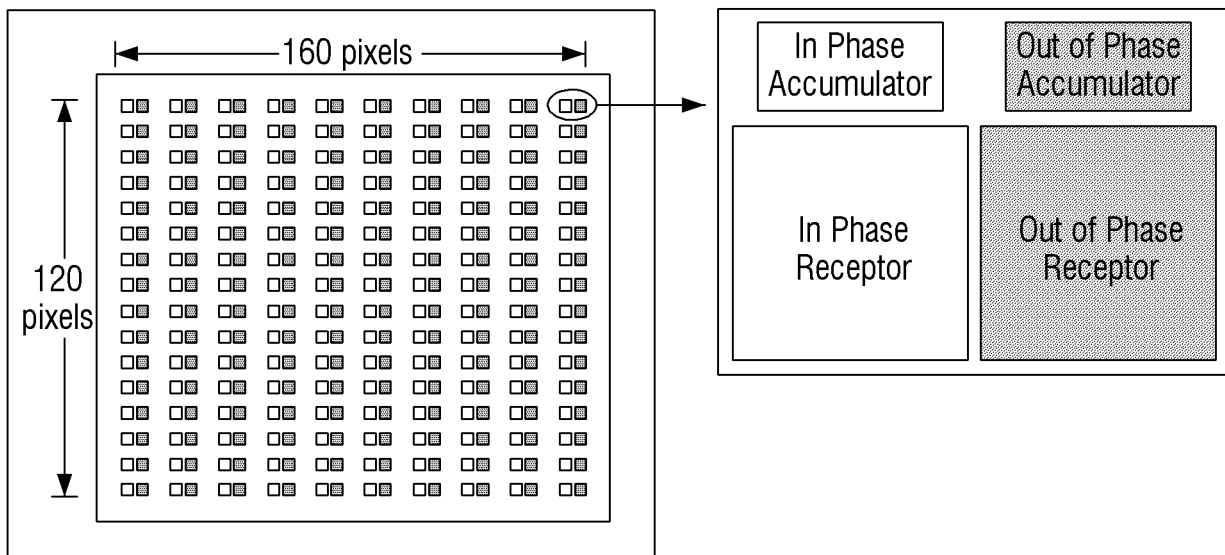

FIG. 4

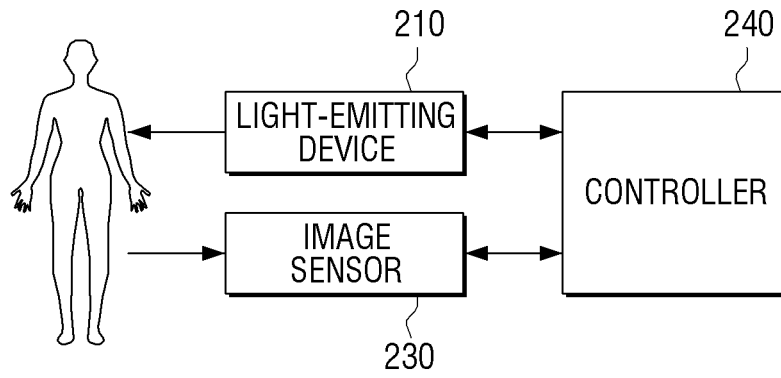

FIG. 5

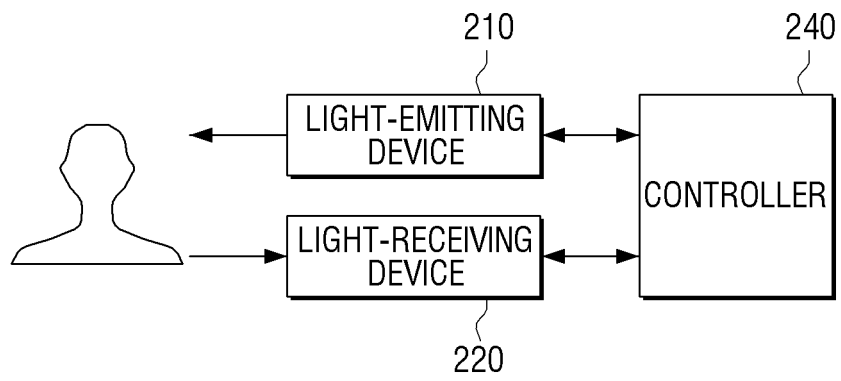

FIG. 6A

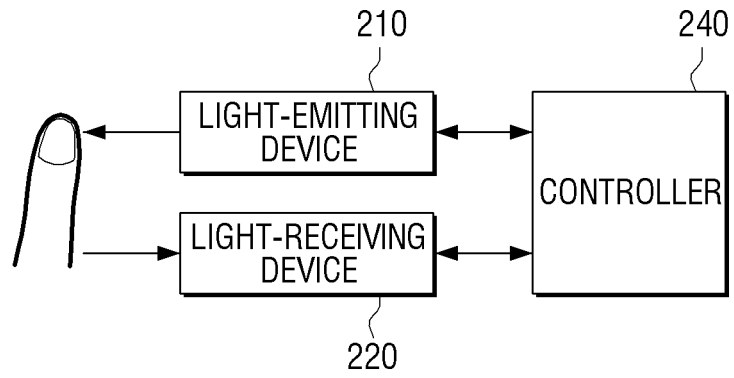

FIG. 6B

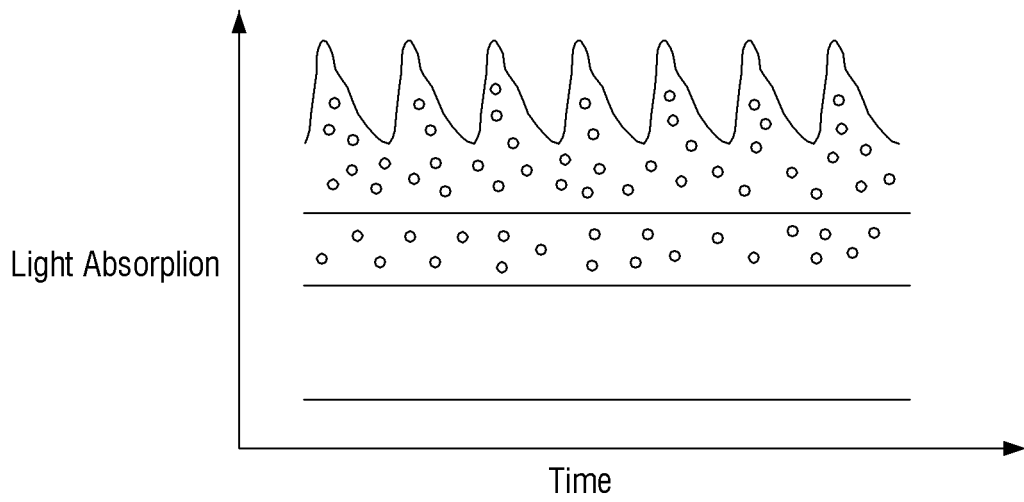

FIG. 6C

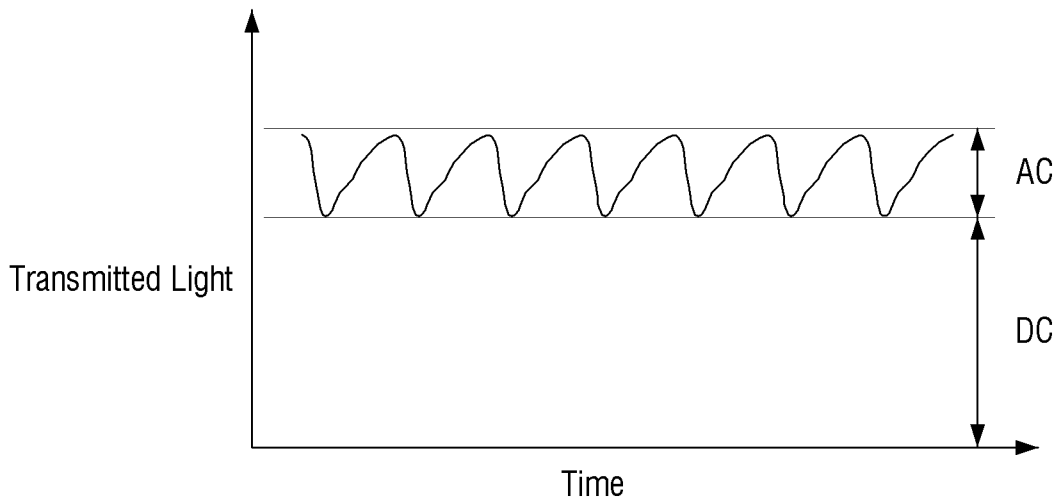

FIG. 7A

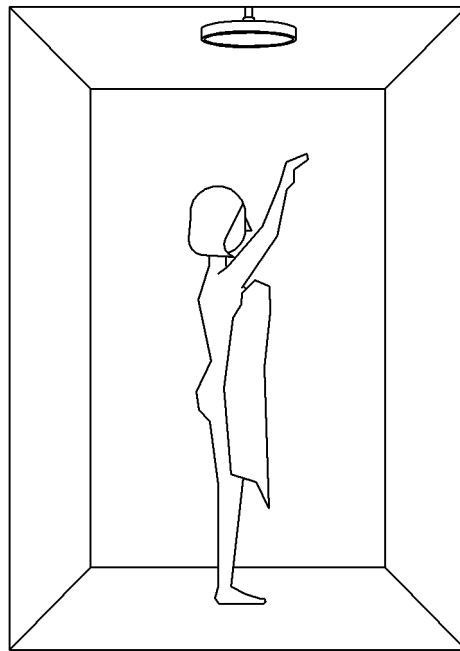

FIG. 7B

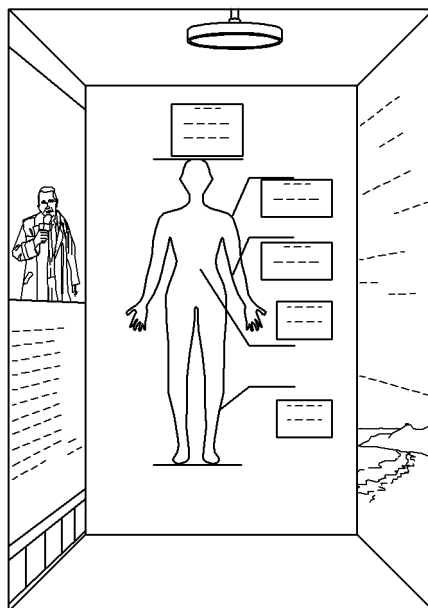

FIG. 8

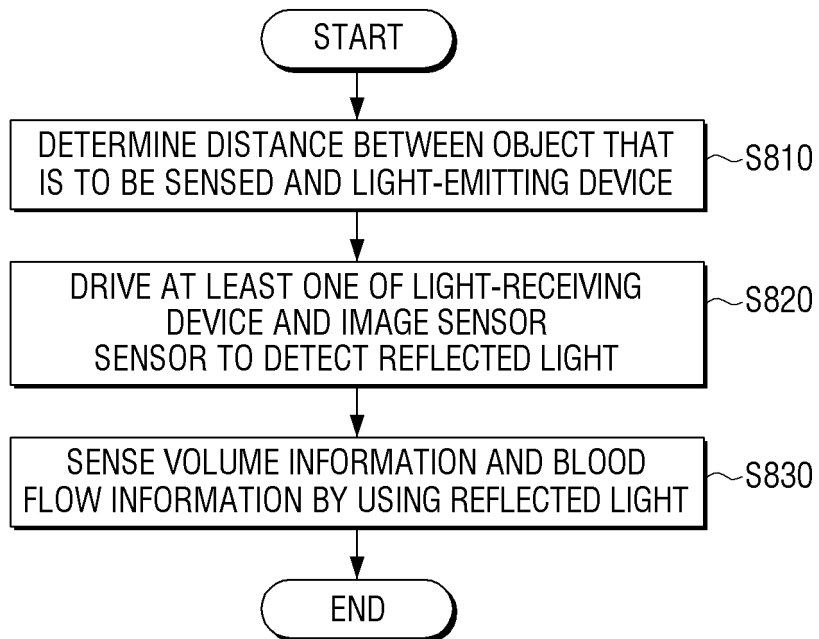

FIG. 9

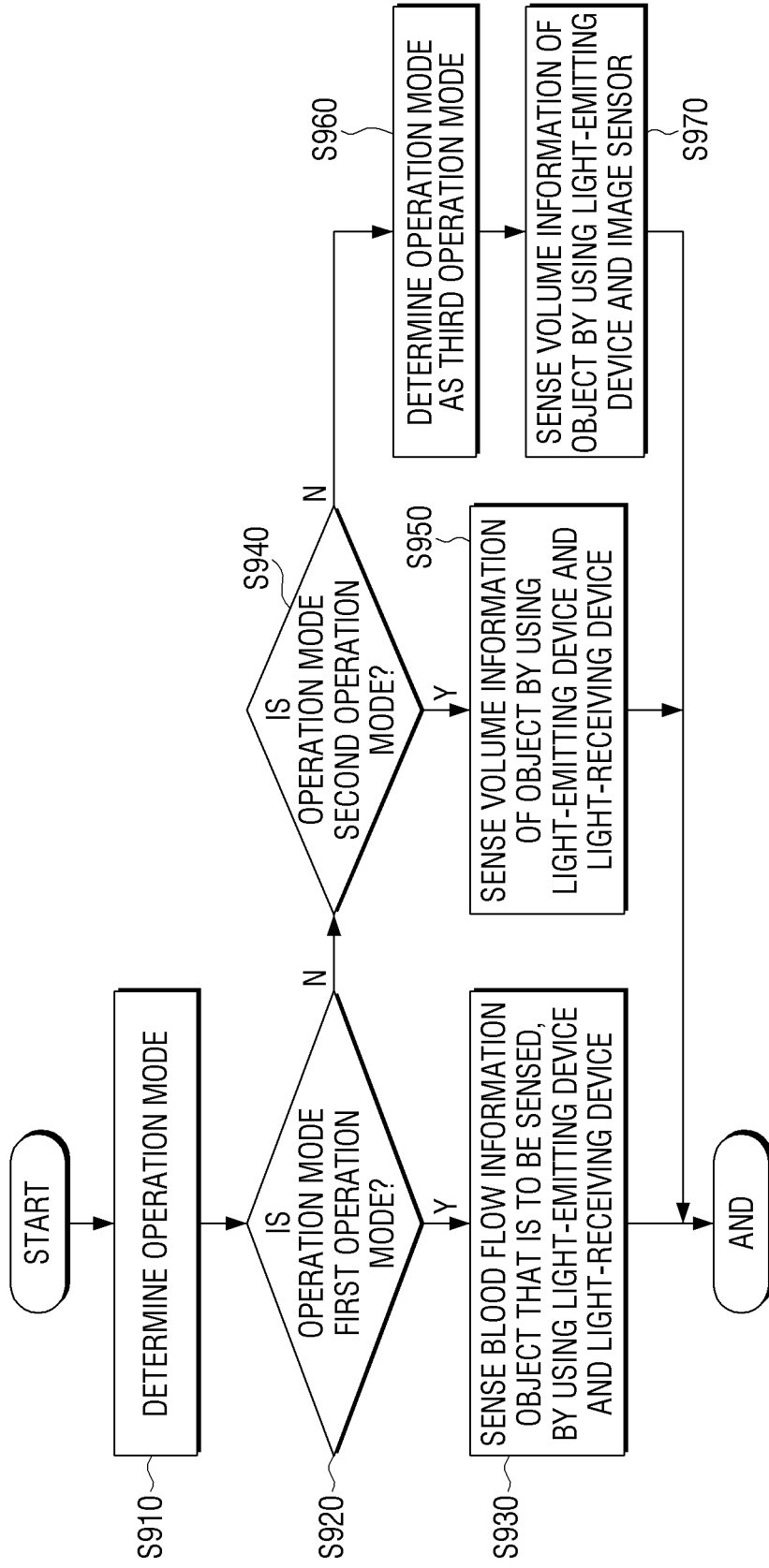

FIG. 10

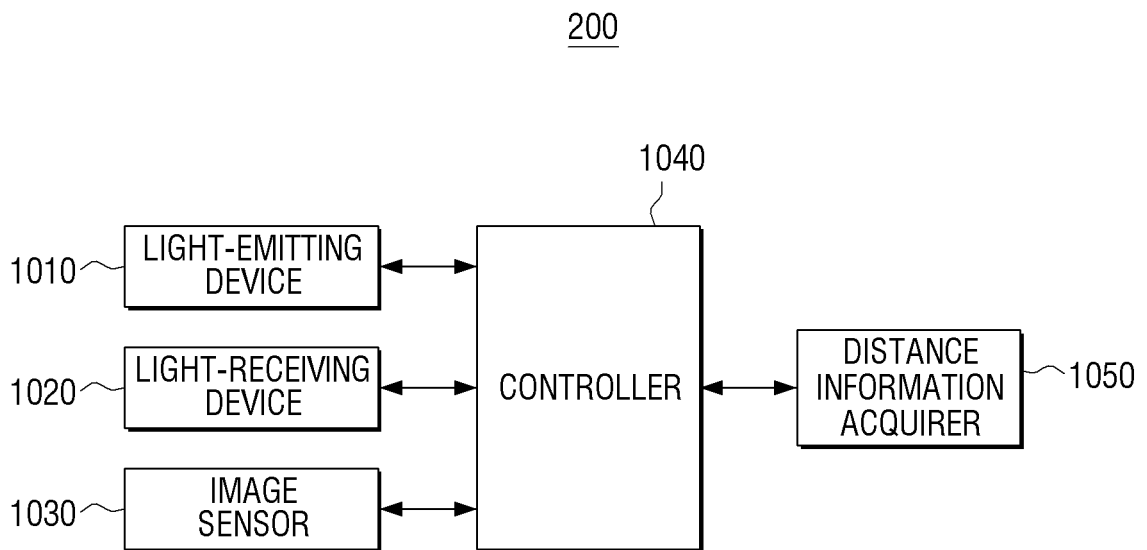

FIG. 11

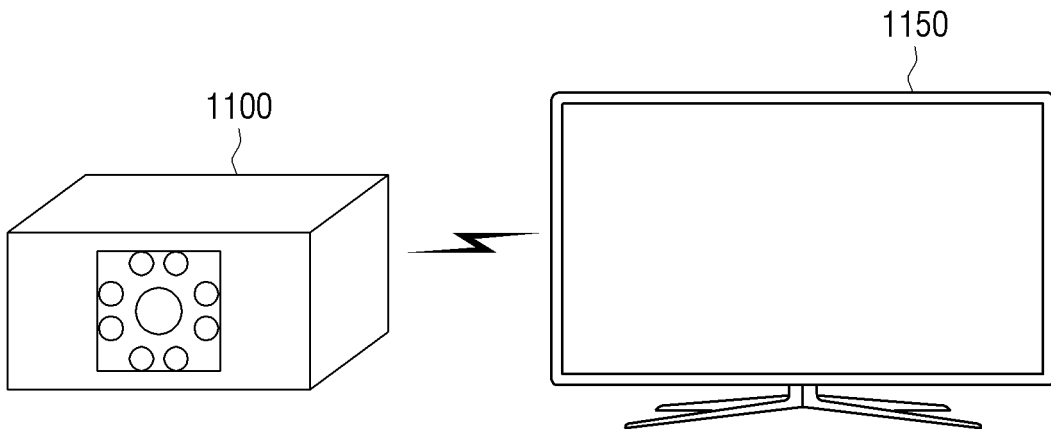

FIG. 12

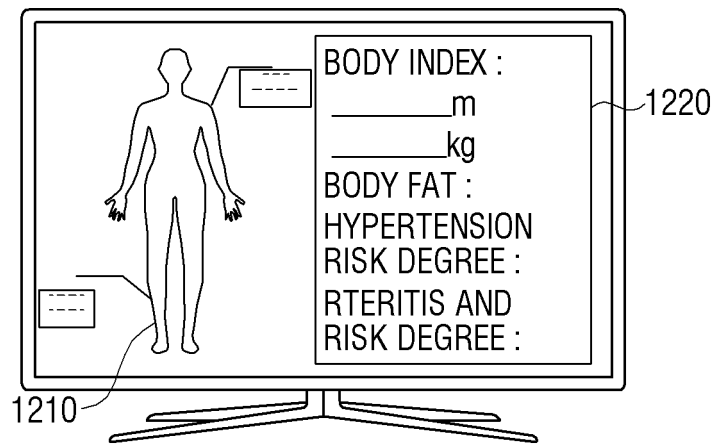

FIG. 13

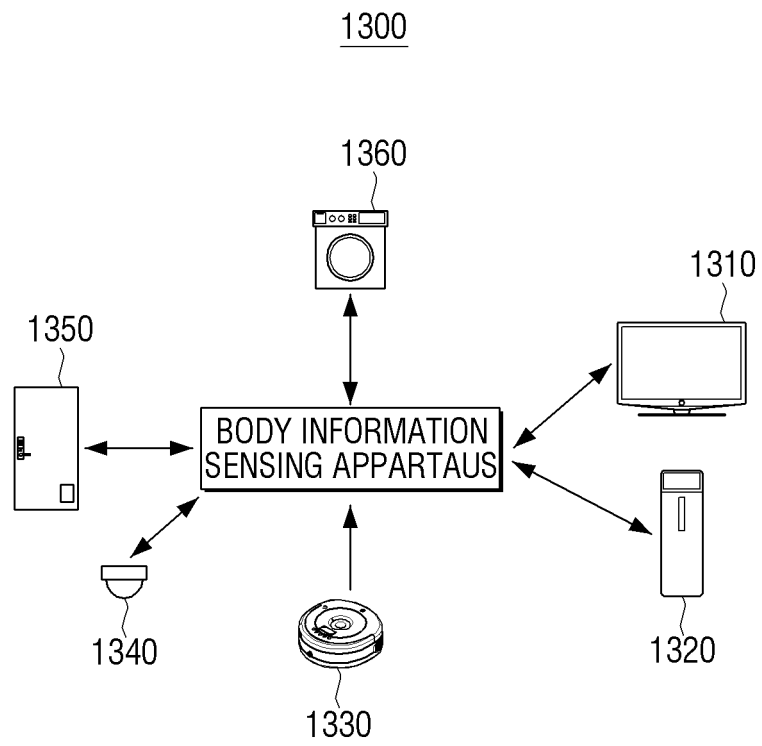

FIG. 14

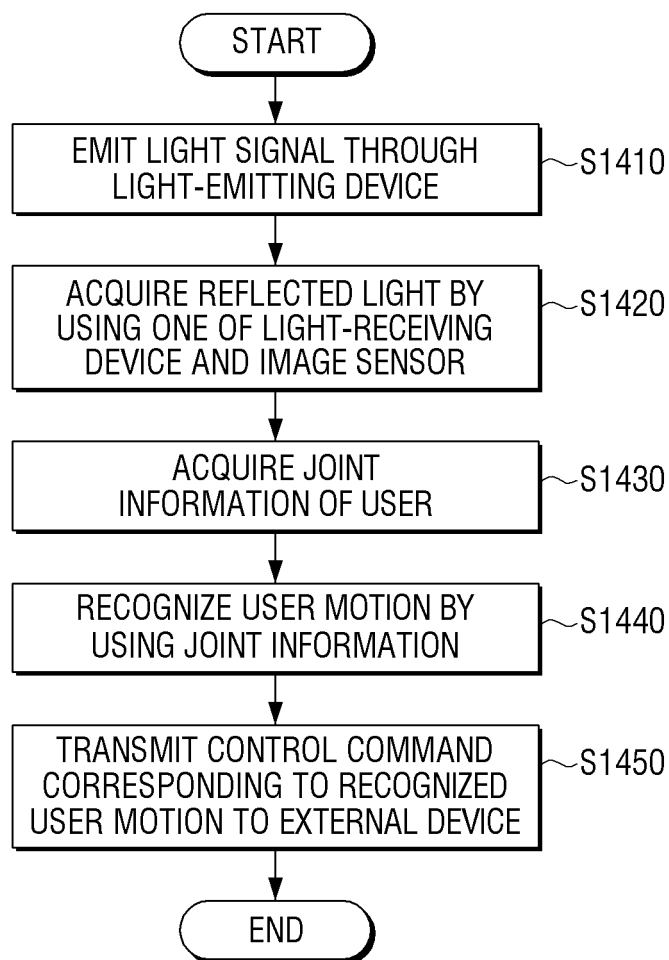

FIG. 15

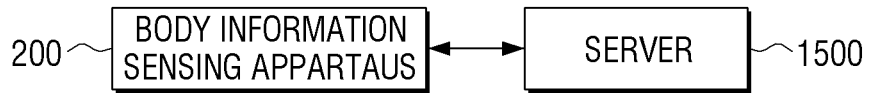
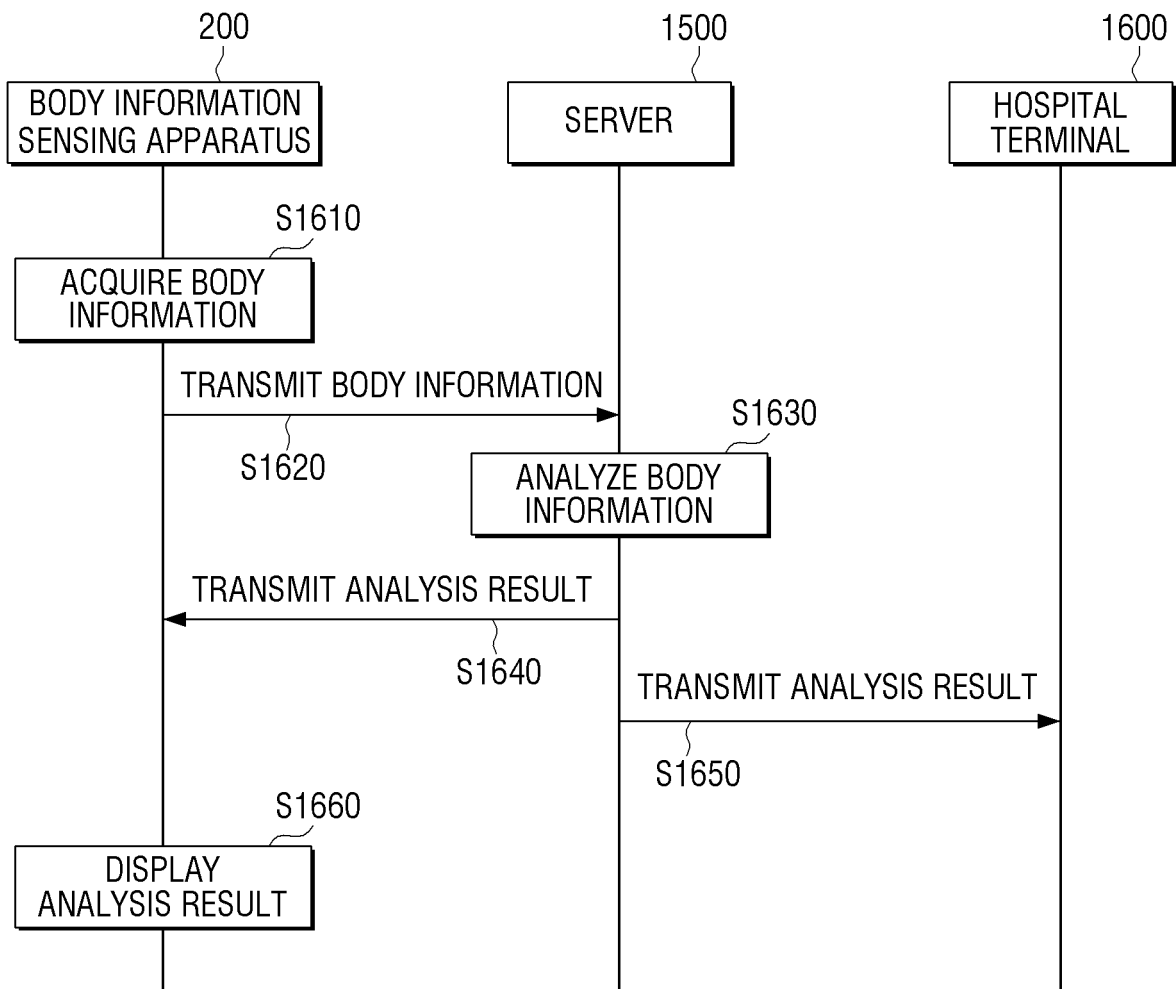

FIG. 16



REFERENCES CITED IN THE DESCRIPTION

This list of references cited by the applicant is for the reader's convenience only. It does not form part of the European patent document. Even though great care has been taken in compiling the references, errors or omissions cannot be excluded and the EPO disclaims all liability in this regard.

Patent documents cited in the description

- WO 2013019904 A2 [0006]
- EP 2281503 A2 [0007]
- JP 2010061294 A [0008]
- WO 2013001265 A2 [0009]

Non-patent literature cited in the description

- **ZIGBEE**. Long Term Evolution (LTE). *3rd Generation (3G), 3rd Generation Partnership Project (3GPP)* [0057]

专利名称(译)	身体信息收集装置和方法		
公开(公告)号	EP2910181B1	公开(公告)日	2020-05-06
申请号	EP2015156119	申请日	2015-02-23
[标]申请(专利权)人(译)	三星电子株式会社		
申请(专利权)人(译)	SAMSUNG ELECTRONICS CO. , LTD.		
当前申请(专利权)人(译)	SAMSUNG ELECTRONICS CO. , LTD.		
[标]发明人	PARK SANG BAE LEE SANG HOON JEONG JAE HOON CHO KYUNG SUN HONG SEONG SEOL LEE DONG JIN CHOI MI JIN		
发明人	PARK, SANG-BAE LEE, SANG-HOON JEONG, JAE-HOON CHO, KYUNG-SUN HONG, SEONG-SEOL LEE, DONG-JIN CHOI, MI-JIN		
IPC分类号	A61B5/00 A61B5/02 A61B5/026 A61B5/107 A61B5/024		
CPC分类号	A61B5/0077 A61B5/02007 A61B5/02416 A61B5/0261 A61B5/1073 A61B5/6844 A61B5/742 A61B5/024		
优先权	1020140021450 2014-02-24 KR		
其他公开文献	EP2910181A1		
外部链接	Espacenet		

摘要(译)

提供了一种用于感测身体信息的设备和方法。该设备包括：发光器件，被配置为向要被感测的物体发射光信号；以及被配置为检测从物体反射的反射光信号的受光装置。图像传感器，被配置为检测从物体反射的反射光信号；控制器，其被配置为根据所述物体与所述发光装置之间的距离来选择性地驱动所述光接收装置和所述图像传感器中的至少一个，并通过使用所述反射光来感测所述物体的体积信息或血流信息信号。

FIG. 1

