



(11) **EP 2 417 904 A9**

(12) **CORRECTED EUROPEAN PATENT APPLICATION**

(15) Correction information:
Corrected version no 1 (W1 A2)
Corrections, see
Description

(51) Int Cl.:
A61B 5/00 (2006.01)

(48) Corrigendum issued on:
06.06.2012 Bulletin 2012/23

(43) Date of publication:
15.02.2012 Bulletin 2012/07

(21) Application number: **11006553.9**

(22) Date of filing: **09.08.2011**

(84) Designated Contracting States:
AL AT BE BG CH CY CZ DE DK EE ES FI FR GB GR HR HU IE IS IT LI LT LU LV MC MK MT NL NO PL PT RO RS SE SI SK SM TR
Designated Extension States:
BA ME

(72) Inventors:
• **Pradeep, Anantha**
Berkeley, CA 94710 (US)
• **Knight, Robert T.**
Berkeley, CA 94710 (US)
• **Gurumoorthy, Ramachandran**
Berkeley, CA 94710 (US)

(30) Priority: **09.08.2010 US 853197**

(71) Applicant: **The Nielsen Company (US), LLC**
Schaumburg, IL 60173 (US)

(74) Representative: **Samson & Partner**
Widenmayerstrasse 5
80538 München (DE)

(54) **Neuro-response evaluated stimulus in virtual reality environments**

(57) A system presents stimulus materials such as products, product packages, displays, services, offerings, etc., in virtual reality environments such as market aisles, store shelves, showroom floors, etc. Sensory experiences output to the user via the virtual reality environment elicit user interactivity. User activity and responses are used to modify marketing materials and/or

virtual reality environments. Neuro-response data including electroencephalography (EEG) data is collected from users in order to evaluate the effectiveness of marketing materials in virtual reality environments. In particular examples, neuro-response data is used to modify marketing materials and virtual reality environments presented to the user.

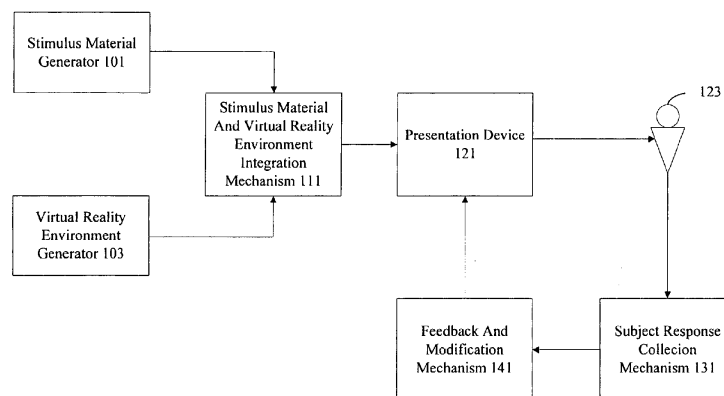

Figure 1A

EP 2 417 904 A9

Description

TECHNICAL FIELD

[0001] The present disclosure relates to using neuro-response data to evaluate marketing and entertainment in virtual reality environments.

DESCRIPTION OF RELATED ART

[0002] Conventional systems for evaluating marketing materials typically involve monitoring and surveying individuals exposed to materials such as products, packages, advertisements, and services. Attempts have been made to present marketing materials in their natural environments such as showrooms, store shelves, displays, etc. However, mechanisms for presenting marketing materials in natural environments are limited. In some examples, individuals are asked to respond to surveys quickly after exposure to marketing materials in actual environments, but information collected is typically limited. Furthermore, conventional systems are subject to brain pattern, semantic, syntactic, metaphorical, cultural, and interpretive errors that prevent accurate and repeatable analyses.

[0003] Consequently, it is desirable to provide improved methods and apparatus for evaluating marketing materials in natural environments that use neuro-response data such as central nervous system, autonomic nervous system, and effector system measurements along with survey based data.

SUMMARY

[0004] The invention relates to a method, a system and a computer program as defined in the appended claims.

[0005] Methods, apparatus, systems and machine readable instructions related to virtual reality environments and stimulus materials are disclosed.

[0006] An example method includes obtaining stimulus material for presentation to a subject, generating a virtual reality environment for the stimulus material and integrating the virtual reality environment and the stimulus material. The example method also includes exposing the subject to the stimulus material in the virtual reality environment and collecting neuro-response data from the subject exposed to the stimulus material in the virtual reality environment. The neuro-response data from the subject is analyzed to determine the effectiveness of stimulus material in the virtual reality environment.

[0007] Another disclosed example includes integrating a stimulus material into a virtual reality environment and exposing a subject to the stimulus material in the virtual reality environment. The example method includes collecting neuro-response data from the subject exposed to the stimulus material in the virtual reality environment and analyzing the neuro-response data to determine the effectiveness of stimulus material in the virtual reality en-

vironment.

[0008] In some example described herein, a method includes dynamically modifying the stimulus material in the virtual reality environment and/or dynamically modifying the virtual reality environment based on the neuro-response data. In some examples, the method receiving and/or collecting interaction data from the subject to manipulate the stimulus material. As described herein, the stimulus material may be one or more of a product, a product package, a service, an offering, a sign and/or a placard. In some examples, the neuro-response data includes electroencephalography (EEG) data. Also, the neuro-response data may be collected using a plurality of modalities including Electronencephalography (EEG) and Electrooculography (EOG). In some examples, the neuro-response data is collected using a plurality of modalities including central nervous system data, autonomic nervous system data and effector data. Another example method disclosed here also includes analyzing neuro-response data including obtaining target and distracter event related potential (ERP) measurements to determine differential measurements of ERP time domain components at multiple regions of the brain (DERP). Also, the analyzing neuro-response data, in some examples, further includes comprises obtaining event related time-frequency analysis of the differential response to assess the attention, emotion and memory retention (DERPSPs) across multiple frequency bands.

[0009] An example system disclosed herein includes an interface configured to obtain stimulus material for presentation to a subject and a processor configured to a virtual reality environment for the stimulus material and integrate the virtual reality environment and the stimulus material. The example system also includes a display configured to expose the subject to the stimulus material in the virtual reality environment and electroencephalography (EEG) electrodes configured to collect neuro-response data from the subject exposed to the stimulus material in the virtual reality environment. Also included in the example system is a data analyzer that is configured to evaluate the neuro-response data from the subject to determine the effectiveness of stimulus material in the virtual reality environment.

[0010] Another example system disclosed herein includes an interface to receive a stimulus material for presentation to a subject and a processor to integrate the stimulus material into a virtual reality environment, the processor to provide the stimulus material and the virtual reality environment to the subject using a display. The example system includes sensors to collect neuro-response data from the subject exposed to the stimulus material in the virtual reality environment and a data analyzer is to evaluate the neuro-response data from the subject to determine the effectiveness of stimulus material in the virtual reality environment.

[0011] The example systems disclosed herein may also include a processor that is to dynamically modify at least one of the stimulus material in the virtual reality

environment or the virtual reality environment based on the neuro-response data. In some examples interaction data is received from the subject to manipulate the stimulus material. The processor may be receive and/or collect the interaction data. The stimulus material, in some example systems, includes one or more of a product, a product package, a service, an offering, a sign and/or a placard. In some example systems, the sensors are to collect the neuro-response data using a plurality of modalities including central nervous system data, autonomic nervous system data and effector data. Also, some of the example systems described herein include a data analyzer to obtain target and distracter event related potential (ERP) measurements to determine differential measurements of ERP time domain components at multiple regions of the brain (DERP). The data analyzer may also obtain event related time-frequency analysis of the differential response to assess the attention, emotion and memory retention (DERPSPs) across multiple frequency bands.

[0012] An example apparatus disclosed herein includes means for obtaining stimulus material for presentation to a subject, means for generating a virtual reality environment for the stimulus material and means for integrating the virtual reality environment and the stimulus material. The example apparatus also includes means for exposing the subject to the stimulus material in the virtual reality environment and means for collecting neuro-response data from the subject exposed to the stimulus material in the virtual reality environment. The neuro-response data from the subject is analyzed to determine the effectiveness of stimulus material in the virtual reality environment.

[0013] An example tangible medium storing machine readable instructions disclosed herein includes instruction which, when executed, cause a machine to at least integrate a stimulus material into a virtual reality environment and expose a subject to the stimulus material in the virtual reality environment. The example instructions also cause a machine to collect neuro-response data from the subject exposed to the stimulus material in the virtual reality environment and analyze the neuro-response data to determine the effectiveness of stimulus material in the virtual reality environment.

BRIEF DESCRIPTION OF THE DRAWINGS

[0014] The disclosure may best be understood by reference to the following description taken in conjunction with the accompanying drawings, which illustrate particular example embodiments.

[0015] Figures 1A-1B illustrate a particular example of a system for evaluating stimulus material in a virtual reality environment.

[0016] Figures 2A-2E illustrate a particular example of a neuro-response data collection mechanism.

[0017] Figure 3 illustrates examples of data models that can be used with a stimulus and response repository.

[0018] Figure 4 illustrates one example of a query that can be used with the neuro-response collection system.

[0019] Figure 5 illustrates one example of a report generated using the neuro-response collection system.

[0020] Figure 6 illustrates one example of a technique for evaluating stimulus material in a virtual reality environment.

[0021] Figure 7 provides one example of a system that can be used to implement one or more mechanisms.

[0022] Description of Particular Embodiments

[0023] Reference will now be made in detail to some specific examples of the invention including the best modes contemplated by the inventors for carrying out the invention. Examples of these specific embodiments are illustrated in the accompanying drawings. While the invention is described in conjunction with these specific embodiments, it will be understood that it is not intended to limit the invention to the described embodiments. On the contrary, it is intended to cover alternatives, modifications, and equivalents as may be included within the spirit and scope of the invention as defined by the appended claims.

[0024] For example, the techniques and mechanisms of the present invention will be described in the context of particular types of stimulus materials. However, it should be noted that the techniques and mechanisms of the present invention apply to a variety of different types of stimulus materials including marketing and entertainment materials. It should be noted that various mechanisms and techniques can be applied to any type of stimuli. In the following description, numerous specific details are set forth in order to provide a thorough understanding of the present invention. Particular example embodiments of the present invention may be implemented without some or all of these specific details. In other instances, well known process operations have not been described in detail in order not to unnecessarily obscure the present invention.

[0025] Various techniques and mechanisms of the present invention will sometimes be described in singular form for clarity. However, it should be noted that some embodiments include multiple iterations of a technique or multiple instantiations of a mechanism unless noted otherwise. For example, a system uses a processor in a variety of contexts. However, it will be appreciated that a system can use multiple processors while remaining within the scope of the present invention unless otherwise noted. Furthermore, the techniques and mechanisms of the present invention will sometimes describe a connection between two entities. It should be noted that a connection between two entities does not necessarily mean a direct, unimpeded connection, as a variety of other entities may reside between the two entities. For example, a processor may be connected to memory, but it will be appreciated that a variety of bridges and controllers may reside between the processor and memory. Consequently, a connection does not necessarily mean a direct, unimpeded connection unless otherwise noted.

[0026] Overview

[0027] A system presents stimulus materials such as products, product packages, displays, services, offerings, etc., in virtual reality environments such as market aisles, store shelves, showroom floors, etc. Sensory experiences output to the user via the virtual reality environment elicit user interactivity. User activity and responses are used to modify marketing materials and/or virtual reality environments. Neuro-response data including electroencephalography (EEG) data is collected from users in order to evaluate the effectiveness of marketing materials in virtual reality environments. In particular examples, neuro-response data is used to modify marketing materials and virtual reality environments presented to the user.

[0028] Example Embodiments

[0029] Marketing materials such as products, product packages, brochures, displays, signs, offerings, and arrangements are typically evaluated by surveying individuals exposed to the marketing materials. Survey responses and focus groups elicit user opinions about the marketing materials. The survey responses and focus groups provide some limited information about the effectiveness of the marketing materials. It is recognized that user responses to marketing materials in a laboratory or evaluation setting can sometimes be different than user responses to the marketing materials in a natural environment, such as a store shelf, a supermarket aisle, a tradeshow floor, building, or a showroom. However, opportunities to evaluate the effectiveness of marketing materials in natural environments are limited.

[0030] In some instances, efforts are made to elicit user responses to marketing materials after users visit actual showrooms, stores, or tradeshows. In other instances, model stores, displays, and mock presentations are set up to test the effectiveness of particular packages, displays, presentations, offerings, etc. However, using actual displays or establishing mock presentations is cumbersome and inflexible. It is highly inefficient to test a variety of presentations or make changes to presentations based on user feedback. Furthermore, even when ample user feedback is obtained, user feedback is subject to brain pattern, semantic, syntactic, metaphorical, cultural, and interpretive errors that prevent accurate and repeatable analyses.

[0031] Consequently, the techniques of the present invention provide mechanisms for evaluating marketing materials presented in virtual reality environments by using neuro-response data. In some examples, neuro-response data along with other survey and focus group data is used to test marketing presentations and displays in virtual reality environments. Virtual reality environments and virtual reality environment templates can be generated to allow reuse, customization, and integration with generated marketing materials.

[0032] Neuro-response data is analyzed to determine the effectiveness of marketing materials presented in various virtual reality environments to particular individuals.

Individuals are provided with mechanisms to interact with the virtual reality environment and marketing materials are manipulated in the framework of the virtual reality environment. Sensors, cameras, microphones, motion detectors, gyroscopes, temperature sensors, etc., can all be used to monitor user responses to allow not only manipulation of the virtual reality environment but modification of the marketing materials presented. In particular embodiments, neuro-response data is used to evaluate the effectiveness of marketing materials and make real-time adjustments and modifications to marketing materials or the virtual reality environment presented.

[0033] Neuro-response measurements such as central nervous system, autonomic nervous system, and effector measurements can be used to evaluate subjects during stimulus presentation. Some examples of central nervous system measurement mechanisms include Functional Magnetic Resonance Imaging (fMRI), Electroencephalography (EEG), Magnetoencephalography (MEG), and Optical Imaging. Optical imaging can be used to measure the absorption or scattering of light related to concentration of chemicals in the brain or neurons associated with neuronal firing. MEG measures magnetic fields produced by electrical activity in the brain. fMRI measures blood oxygenation in the brain that correlates with increased neural activity. However, current implementations of fMRI have poor temporal resolution of few seconds. EEG measures electrical activity associated with post synaptic currents occurring in the milliseconds range. Subcranial EEG can measure electrical activity with the most accuracy, as the bone and dermal layers weaken transmission of a wide range of frequencies. Nonetheless, surface EEG provides a wealth of electrophysiological information if analyzed properly. Even portable EEG with dry electrodes provides a large amount of neuro-response information.

[0034] Autonomic nervous system measurement mechanisms include Electrocardiograms (EKG) and pupillary dilation, etc. Effector measurement mechanisms include Electrooculography (EOG), eye tracking, facial emotion encoding, reaction time etc.

[0035] Multiple modes and manifestations of precognitive neural signatures are blended with cognitive neural signatures and post cognitive neurophysiological manifestations to more accurately perform neuro-response analysis. In some examples, autonomic nervous system measures are themselves used to validate central nervous system measures. Effector and behavior responses are blended and combined with other measures. According to various embodiments, central nervous system, autonomic nervous system, and effector system measurements are aggregated into a measurement that allows evaluation of stimulus material effectiveness in particular environments.

[0036] In particular embodiments, subjects are exposed to stimulus material and data such as central nervous system, autonomic nervous system, and effector data is collected during exposure. According to various em-

bodiments, data is collected in order to determine a resonance measure that aggregates multiple component measures that assess resonance data. In particular embodiments, specific event related potential (ERP) analyses and/or event related power spectral perturbations (ERPSPs) are evaluated for different regions of the brain both before a subject is exposed to stimulus and each time after the subject is exposed to stimulus.

[0037] According to various embodiments, pre-stimulus and post-stimulus differential as well as target and distracter differential measurements of ERP time domain components at multiple regions of the brain are determined (DERP). Event related time-frequency analysis of the differential response to assess the attention, emotion and memory retention (DERPSPs) across multiple frequency bands including but not limited to theta, alpha, beta, gamma and high gamma is performed. In particular embodiments, single trial and/or averaged DERP and/or DERPSPs can be used to enhance the resonance measure and determine priming levels for various products and services.

[0038] According to various embodiments, enhanced neuro-response data is generated using a data analyzer that performs both intra-modality measurement enhancements and cross-modality measurement enhancements. According to various embodiments, brain activity is measured not just to determine the regions of activity, but to determine interactions and types of interactions between various regions. The techniques and mechanisms of the present invention recognize that interactions between neural regions support orchestrated and organized behavior. Attention, emotion, memory, and other abilities are not merely based on one part of the brain but instead rely on network interactions between brain regions.

[0039] The techniques and mechanisms of the present invention further recognize that different frequency bands used for multi-regional communication can be indicative of the effectiveness of stimuli. In particular embodiments, evaluations are calibrated to each subject and synchronized across subjects. In particular embodiments, templates are created for subjects to create a baseline for measuring pre and post stimulus differentials. According to various embodiments, stimulus generators are intelligent and adaptively modify specific parameters such as exposure length and duration for each subject being analyzed.

[0040] A variety of modalities can be used including EEG, GSR, EKG, pupillary dilation, EOG, eye tracking, facial emotion encoding, reaction time, etc. Individual modalities such as EEG are enhanced by intelligently recognizing neural region communication pathways. Cross modality analysis is enhanced using a synthesis and analytical blending of central nervous system, autonomic nervous system, and effector signatures. Synthesis and analysis by mechanisms such as time and phase shifting, correlating, and validating intra-modal determinations allow generation of a composite output charac-

terizing the significance of various data responses.

[0041] According to various embodiments, survey based and actual expressed responses and actions for particular groups of users are integrated with neuro-response data and stored in a stimulus material and virtual reality environment. According to particular embodiments, pre-articulation predictions of expressive response for various stimulus material can be made by analyzing neuro-response data.

[0042] Figure 1A illustrates one example of a system for present marketing materials in virtual reality environments. According to various embodiments, a stimulus material generator 101 constructs products, product packages, displays, labels, boxes, signs, offerings, and advertising using custom or template designs. In particular examples, companies, firms, and individuals wanting to test marketing materials provide the designs that can be incorporated into designs or wireframes for use in virtual reality environments. A virtual reality environment generator 103 can similarly construct custom or template based designs for store aisles, shopping malls, showrooms, tradeshow floors, etc., that can be integrated with marketing materials 101 using a stimulus material and virtual reality integration mechanism 111.

[0043] The integrated marketing materials and virtual reality environment are provided to a presentation device 121. The presentation device 121 may include screens, headsets, domes, multidimensional displays, speakers, motion simulation devices, movable platforms, smell generators, etc., to provide the subject 123 with a simulated environment. Subject response collection mechanism 131 may include cameras recorders, motion detectors, etc., that capture subject activity and responses. According to various embodiments, neuro-response data collection mechanisms are also used to capture neuro-response data such as electroencephalography (EEG) data for the subject presented with stimulus materials. In particular embodiments, feedback and modification mechanism 141 uses subject responses to modify marketing materials and/or the virtual reality environment based on subject actions. According to various embodiments, product packages may be manipulated by a subject in the virtual reality environment. In particular embodiments, store displays may be viewed from different angles, products may be opened, etc.

[0044] According to various embodiments, neuro-response data including EEG data is used to make real-time modifications to marketing materials and virtual reality environments. In particular embodiments, lack of interest is detected using neuro-response data and different marketing materials are dynamically presented to the user as the user moves along in a grocery aisle.

[0045] Figure 1B illustrates one example of a neuro-response data collection mechanism that can be used with users exposed to stimulus material in virtual reality environments. According to various embodiments, the virtual reality stimulus presentation includes a stimulus presentation in virtual reality environments device 151.

In particular embodiments, the virtual reality environment presentation device 151 is merely a display, monitor, screen, etc., that displays stimulus material in the context of a virtual reality environment to a user. The stimulus material may be a product, product package, service, offering, advertisement, placard, brochure, etc., placed in the context of a supermarket aisle, convenience store, room, etc.

[0046] The stimuli can involve a variety of senses and occur with or without human supervision. Continuous and discrete modes are supported. According to various embodiments, the virtual reality environment presentation device 151 also has protocol generation capability to allow intelligent customization of stimulus and environments provided to multiple subjects in different settings such as laboratory, corporate, and home settings.

[0047] According to various embodiments, virtual reality environment presentation device 151 could include devices such as headsets, goggles, projection systems, display devices, speakers, tactile surfaces, etc., for presenting the stimulus in virtual reality environments.

[0048] According to various embodiments, the subjects 153 are connected to data collection devices 155. The data collection devices 155 may include a variety of neuro-response measurement mechanisms including neurological and neurophysiological measurements systems such as EEG, EOG, MEG, pupillary dilation, eye tracking, facial emotion encoding, and reaction time devices, etc. According to various embodiments, neuro-response data includes central nervous system, autonomic nervous system, and effector data. In particular embodiments, the data collection devices 155 include EEG 161, EOG 163, and fMRI 165. In some instances, only a single data collection device is used. Data collection may proceed with or without human supervision.

[0049] The data collection device 155 collects neuro-response data from multiple sources. This includes a combination of devices such as central nervous system sources (EEG), autonomic nervous system sources (EKG, pupillary dilation), and effector sources (EOG, eye tracking, facial emotion encoding, reaction time). In particular embodiments, data collected is digitally sampled and stored for later analysis. In particular embodiments, the data collected could be analyzed in real-time. According to particular embodiments, the digital sampling rates are adaptively chosen based on the neurophysiological and neurological data being measured.

[0050] In one particular embodiment, the system includes EEG 161 measurements made using scalp level electrodes, EOG 163 measurements made using shielded electrodes to track eye data, fMRI 165 measurements performed using a differential measurement system, a facial muscular measurement through shielded electrodes placed at specific locations on the face, and a facial affect graphic and video analyzer adaptively derived for each individual.

[0051] In particular embodiments, the data collection devices are clock synchronized with a virtual reality en-

vironment presentation device 151. In particular embodiments, the data collection devices 155 also include a condition evaluation subsystem that provides auto triggers, alerts and status monitoring and visualization components that continuously monitor the status of the subject, data being collected, and the data collection instruments. The condition evaluation subsystem may also present visual alerts and automatically trigger remedial actions. According to various embodiments, the data collection devices include mechanisms for not only monitoring subject neuro-response to stimulus materials, but also include mechanisms for identifying and monitoring the stimulus materials. For example, data collection devices 155 may be synchronized with a set-top box to monitor channel changes. In other examples, data collection devices 155 may be directionally synchronized to monitor when a subject is no longer paying attention to stimulus material. In still other examples, the data collection devices 155 may receive and store stimulus material generally being viewed by the subject, whether the stimulus is a program, a commercial, printed material, or a scene outside a window. The data collected allows analysis of neuro-response information and correlation of the information to actual stimulus material and not mere subject distractions.

[0052] According to various embodiments, the virtual reality stimulus presentation system also includes a data cleanser device 171. In particular embodiments, the data cleanser device 171 filters the collected data to remove noise, artifacts, and other irrelevant data using fixed and adaptive filtering, weighted averaging, advanced component extraction (like PCA, ICA), vector and component separation methods, etc. This device cleanses the data by removing both exogenous noise (where the source is outside the physiology of the subject, e.g. a phone ringing while a subject is viewing a video) and endogenous artifacts (where the source could be neurophysiological, e.g. muscle movements, eye blinks, etc.).

[0053] The artifact removal subsystem includes mechanisms to selectively isolate and review the response data and identify epochs with time domain and/or frequency domain attributes that correspond to artifacts such as line frequency, eye blinks, and muscle movements. The artifact removal subsystem then cleanses the artifacts by either omitting these epochs, or by replacing these epoch data with an estimate based on the other clean data (for example, an EEG nearest neighbor weighted averaging approach).

[0054] According to various embodiments, the data cleanser device 171 is implemented using hardware, firmware, and/or software. It should be noted that although a data cleanser device 171 is shown located after a data collection device 155, the data cleanser device 171 like other components may have a location and functionality that varies based on system implementation. For example, some systems may not use any automated data cleanser device whatsoever while in other systems, data cleanser devices may be integrated into individual

data collection devices.

[0055] In particular embodiments, a survey and interview system collects and integrates user survey and interview responses to combine with neuro-response data to more effectively perform virtual reality stimulus presentation. According to various embodiments, the survey and interview system obtains information about user characteristics such as age, gender, income level, location, interests, buying preferences, hobbies, etc.

[0056] According to various embodiments, the virtual reality stimulus presentation system includes a data analyzer 173 associated with the data cleanser 171. The data analyzer 173 uses a variety of mechanisms to analyze underlying data in the system to determine resonance. According to various embodiments, the data analyzer 173 customizes and extracts the independent neurological and neuro-physiological parameters for each individual in each modality, and blends the estimates within a modality as well as across modalities to elicit an enhanced response to the presented stimulus material. In particular embodiments, the data analyzer 173 aggregates the response measures across subjects in a dataset.

[0057] According to various embodiments, neurological and neuro-physiological signatures are measured using time domain analyses and frequency domain analyses. Such analyses use parameters that are common across individuals as well as parameters that are unique to each individual. The analyses could also include statistical parameter extraction and fuzzy logic based attribute estimation from both the time and frequency components of the synthesized response.

[0058] In some examples, statistical parameters used in a blended effectiveness estimate include evaluations of skew, peaks, first and second moments, distribution, as well as fuzzy estimates of attention, emotional engagement and memory retention responses.

[0059] According to various embodiments, the data analyzer 173 may include an intra-modality response synthesizer and a cross-modality response synthesizer. In particular embodiments, the intra-modality response synthesizer is configured to customize and extract the independent neurological and neurophysiological parameters for each individual in each modality and blend the estimates within a modality analytically to elicit an enhanced response to the presented stimuli. In particular embodiments, the intra-modality response synthesizer also aggregates data from different subjects in a dataset.

[0060] According to various embodiments, the cross-modality response synthesizer or fusion device blends different intra-modality responses, including raw signals and signals output. The combination of signals enhances the measures of effectiveness within a modality. The cross-modality response fusion device can also aggregate data from different subjects in a dataset.

[0061] According to various embodiments, the data analyzer 173 also includes a composite enhanced effectiveness estimator (CEEE) that combines the enhanced

responses and estimates from each modality to provide a blended estimate of the effectiveness. In particular embodiments, blended estimates are provided for each exposure of a subject to stimulus materials. The blended estimates are evaluated over time to assess resonance characteristics. According to various embodiments, numerical values are assigned to each blended estimate. The numerical values may correspond to the intensity of neuro-response measurements, the significance of peaks, the change between peaks, etc. Higher numerical values may correspond to higher significance in neuro-response intensity. Lower numerical values may correspond to lower significance or even insignificant neuro-response activity. In other examples, multiple values are assigned to each blended estimate. In still other examples, blended estimates of neuro-response significance are graphically represented to show changes after repeated exposure.

[0062] According to various embodiments, a data analyzer 173 passes data to a resonance estimator that assesses and extracts resonance patterns. In particular embodiments, the resonance estimator determines entity positions in various stimulus segments and matches position information with eye tracking paths while correlating saccades with neural assessments of attention, memory retention, and emotional engagement. In particular embodiments, the resonance estimator stores data in the priming repository system. As with a variety of the components in the system, various repositories can be co-located with the rest of the system and the user, or could be implemented in remote locations.

[0063] Data from various repositories is blended and passed to a virtual reality stimulus presentation engine to generate patterns, responses, and predictions 175. In some embodiments, the virtual reality stimulus presentation engine compares patterns and expressions associated with prior users to predict expressions of current users. According to various embodiments, patterns and expressions are combined with orthogonal survey, demographic, and preference data. In particular embodiments linguistic, perceptual, and/or motor responses are elicited and predicted. Response expression selection and pre-articulation prediction of expressive responses are also evaluated.

[0064] Figures 2A-2E illustrate a particular example of a neuro-response data collection mechanism. Figure 2A shows a perspective view of a neuro-response data collection mechanism including multiple dry electrodes. According to various embodiments, the neuro-response data collection mechanism is a headset having point or teeth electrodes configured to contact the scalp through hair without the use of electro-conductive gels. In particular embodiments, each electrode is individually amplified and isolated to enhance shielding and routability. In some examples, each electrode has an associated amplifier implemented using a flexible printed circuit. Signals may be routed to a controller/processor for immediate transmission to a data analyzer or stored for later analysis. A

controller/processor may be used to synchronize neuro-response data with stimulus materials. The neuro-response data collection mechanism may also have receivers for receiving clock signals and processing neuro-response signals. The neuro-response data collection mechanisms may also have transmitters for transmitting clock signals and sending data to a remote entity such as a data analyzer.

[0065] Figures 2B-2E illustrate top, side, rear, and perspective views of the neuro-response data collection mechanism. The neuro-response data collection mechanism includes multiple electrodes including right side electrodes 261 and 263, left side electrodes 221 and 223, front electrodes 231 and 233, and rear electrode 251. It should be noted that specific electrode arrangement may vary from implementation to implementation. However, the techniques and mechanisms of the present invention avoid placing electrodes on the temporal region to prevent collection of signals generated based on muscle contractions. Avoiding contact with the temporal region also enhances comfort during sustained wear.

[0066] According to various embodiments, forces applied by electrodes 221 and 223 counterbalance forces applied by electrodes 261 and 263. In particular embodiments, forces applied by electrodes 231 and 233 counterbalance forces applied by electrode 251. In particular embodiments, the EEG dry electrodes operate to detect neurological activity with minimal interference from hair and without use of any electrically conductive gels. According to various embodiments, neuro-response data collection mechanism also includes EOG sensors such as sensors used to detect eye movements.

[0067] According to various embodiments, data acquisition using electrodes 221, 223, 231, 233, 251, 261, and 263 is synchronized with stimulus material presented to a user. Data acquisition can be synchronized with stimulus material presented by using a shared clock signal. The shared clock signal may originate from the stimulus material presentation mechanism, a headset, a cell tower, a satellite, etc. The data collection mechanism 201 also includes a transmitter and/or receiver to send collected neuro-response data to a data analysis system and to receive clock signals as needed. In some examples, a transceiver transmits all collected media such as video and/or audio, neuro-response, and sensor data to a data analyzer. In other examples, a transceiver transmits only interesting data provided by a filter. According to various embodiments, neuro-response data is correlated with timing information for stimulus material presented to a user.

[0068] In some examples, the transceiver can be connected to a computer system that then transmits data over a wide area network to a data analyzer. In other examples, the transceiver sends data over a wide area network to a data analyzer. Other components such as fMRI and MEG that are not yet portable but may become portable at some point may also be integrated into a headset.

[0069] It should be noted that some components of a neuro-response data collection mechanism have not been shown for clarity. For example, a battery may be required to power components such as amplifiers and transceivers. Similarly, a transceiver may include an antenna that is similarly not shown for clarity purposes. It should also be noted that some components are also optional. For example, filters or storage may not be required.

[0070] Figure 3 illustrates examples of data models that can be used for storage of information associated with collection of neuro-response data. According to various embodiments, a dataset data model 301 includes a name 303 and/or identifier, client attributes 305, a subject pool 307, logistics information 309 such as the location, date, and stimulus material 311 identified using user entered information or video and audio detection.

[0071] In particular embodiments, a subject attribute data model 315 includes a subject name 317 and/or identifier, contact information 321, and demographic attributes 319 that may be useful for review of neurological and neuro-physiological data. Some examples of pertinent demographic attributes include marriage status, employment status, occupation, household income, household size and composition, ethnicity, geographic location, sex, race. Other fields that may be included in data model 315 include shopping preferences, entertainment preferences, and financial preferences. Shopping preferences include favorite stores, shopping frequency, categories shopped, favorite brands. Entertainment preferences include network/cable/satellite access capabilities, favorite shows, favorite genres, and favorite actors. Financial preferences include favorite insurance companies, preferred investment practices, banking preferences, and favorite online financial instruments. A variety of subject attributes may be included in a subject attributes data model 315 and data models may be preset or custom generated to suit particular purposes.

[0072] Other data models may include a data collection data model 337. According to various embodiments, the data collection data model 337 includes recording attributes 339, equipment identifiers 341, modalities recorded 343, and data storage attributes 345. In particular embodiments, equipment attributes 341 include an amplifier identifier and a sensor identifier.

[0073] Modalities recorded 343 may include modality specific attributes like EEG cap layout, active channels, sampling frequency, and filters used. EOG specific attributes include the number and type of sensors used, location of sensors applied, etc. Eye tracking specific attributes include the type of tracker used, data recording frequency, data being recorded, recording format, etc. According to various embodiments, data storage attributes 345 include file storage conventions (format, naming convention, dating convention), storage location, archival attributes, expiry attributes, etc.

[0074] A preset query data model 349 includes a query name 351 and/or identifier, an accessed data collection

353 such as data segments involved (models, databases/cubes, tables, etc.), access security attributes 355 included who has what type of access, and refresh attributes 357 such as the expiry of the query, refresh frequency, etc. Other fields such as push-pull preferences can also be included to identify an auto push reporting driver or a user driven report retrieval system.

[0075] Figure 4 illustrates examples of queries that can be performed to obtain data associated with neuro-response data collection. According to various embodiments, queries are defined from general or customized scripting languages and constructs, visual mechanisms, a library of preset queries, diagnostic querying including drill-down diagnostics, and eliciting what if scenarios. According to various embodiments, subject attributes queries 415 may be configured to obtain data from a neuro-informatics repository using a location 417 or geographic information, session information 421 such as timing information for the data collected. Location information 423 may also be collected. In some examples, a neuro-response data collection mechanism includes GPS or other location detection mechanisms. Demographics attributes 419 include household income, household size and status, education level, age of kids, etc.

[0076] Other queries may retrieve stimulus material recorded based on shopping preferences of subject participants, countenance, physiological assessment, completion status. For example, a user may query for data associated with product categories, products shopped, shops frequented, subject eye correction status, color blindness, subject state, signal strength of measured responses, alpha frequency band ringers, muscle movement assessments, segments completed, etc.

[0077] Response assessment based queries 437 may include attention scores 439, emotion scores, 441, retention scores 443, and effectiveness scores 445. Such queries may obtain materials that elicited particular scores. Response measure profile based queries may use mean measure thresholds, variance measures, number of peaks detected, etc. Group response queries may include group statistics like mean, variance, kurtosis, p-value, etc., group size, and outlier assessment measures. Still other queries may involve testing attributes like test location, time period, test repetition count, test station, and test operator fields. A variety of types and combinations of types of queries can be used to efficiently extract data.

[0078] Figure 5 illustrates examples of reports that can be generated. According to various embodiments, client assessment summary reports 501 include effectiveness measures 503, component assessment measures 505, and neuro-response data collection measures 507. Effectiveness assessment measures include composite assessment measure(s), industry/category/client specific placement (percentile, ranking, etc.), actionable grouping assessment such as removing material, modifying segments, or fine tuning specific elements, etc, and the evolution of the effectiveness profile over time. In partic-

ular embodiments, component assessment reports include component assessment measures like attention, emotional engagement scores, percentile placement, ranking, etc. Component profile measures include time based evolution of the component measures and profile statistical assessments. According to various embodiments, reports include the number of times material is assessed, attributes of the multiple presentations used, evolution of the response assessment measures over the multiple presentations, and usage recommendations.

[0079] According to various embodiments, client cumulative reports 511 include media grouped reporting 513 of all stimulus assessed, campaign grouped reporting 515 of stimulus assessed, and time/location grouped reporting 517 of stimulus assessed. According to various embodiments, industry cumulative and syndicated reports 521 include aggregate assessment responses measures 523, top performer lists 525, bottom performer lists 527, outliers 529, and trend reporting 531. In particular embodiments, tracking and reporting includes specific products, categories, companies, brands.

[0080] Figure 6 illustrates one example of evaluation of stimulus presentation in a virtual reality environment. At 601, user information is received from a subject provided with a neuro-response data collection mechanism. According to various embodiments, the subject provides data including age, gender, income, location, interest, ethnicity, etc. At 603, stimulus material is received. In particular embodiments, stimulus material is received from companies, firms, individuals, etc., seeking to evaluate their products, product labels, displays, brochures, services, offerings, etc., in a virtual reality environment. In particular examples, stimulus material is dynamically generated using information provided by advertisers. According to various embodiments, a virtual reality environment appropriate for the stimulus material is selected and customized at 605. Virtual reality environments may include super market aisles, shopping centers, store shelves, showrooms, trade show floors, offices, etc.

[0081] At 607, stimulus material is integrated into a virtual reality environment and presented to a user. At 609, interaction data is received from users exposed to stimulus material. Interaction data may be received from haptic gloves, platforms, sensors, cameras, microphones, platforms, magnetic fields, controllers, etc.

[0082] At 611, neuro-response data is received from the subject neuro-response data collection mechanism. In some particular embodiments, EEG, EOG, pupillary dilation, facial emotion encoding data, video, images, audio, GPS data, etc., can all be transmitted from the subject to a neuro-response data analyzer. In particular embodiments, only EEG data is transmitted. At 613, stimulus material and the virtual reality environment is modified based on user interaction. In particular embodiments, products may be manipulated by the user in the virtual reality environment. According to various embodiments, stimulus material and/or the virtual reality environment can also be modified based on neuro-response data at

615. In particular embodiments, if a user is determined to be losing interest in a product, a different product may be presented. Alternatively, a different environment displaying the product may be presented after a transition from one store to another. According to various embodiments, neuro-response and associated data is transmitted directly from an EEG cap wide area network interface to a data analyzer. In particular embodiments, neuro-response and associated data is transmitted to a computer system that then performs compression and filtering of the data before transmitting the data to a data analyzer over a network.

[0083] According to various embodiments, data is also passed through a data cleanser to remove noise and artifacts that may make data more difficult to interpret. According to various embodiments, the data cleanser removes EEG electrical activity associated with blinking and other endogenous/exogenous artifacts. Data cleansing may be performed before or after data transmission to a data analyzer.

[0084] At 617, neuro-response data is synchronized with timing, environment, and other stimulus material data. In particular embodiments, neuro-response data is synchronized with a shared clock source. According to various embodiments, neuro-response data such as EEG and EOG data is tagged to indicate what the subject is viewing or listening to at a particular time.

[0085] At 619, data analysis is performed. Data analysis may include intra-modality response synthesis and cross-modality response synthesis to enhance effectiveness measures. It should be noted that in some particular instances, one type of synthesis may be performed without performing other types of synthesis. For example, cross-modality response synthesis may be performed with or without intra-modality synthesis.

[0086] A variety of mechanisms can be used to perform data analysis 609. In particular embodiments, a stimulus attributes repository is accessed to obtain attributes and characteristics of the stimulus materials, along with purposes, intents, objectives, etc. In particular embodiments, EEG response data is synthesized to provide an enhanced assessment of effectiveness. According to various embodiments, EEG measures electrical activity resulting from thousands of simultaneous neural processes associated with different portions of the brain. EEG data can be classified in various bands. According to various embodiments, brainwave frequencies include delta, theta, alpha, beta, and gamma frequency ranges. Delta waves are classified as those less than 4 Hz and are prominent during deep sleep. Theta waves have frequencies between 3.5 to 7.5 Hz and are associated with memories, attention, emotions, and sensations. Theta waves are typically prominent during states of internal focus.

[0087] Alpha frequencies reside between 7.5 and 13Hz and typically peak around 10Hz. Alpha waves are prominent during states of relaxation. Beta waves have a frequency range between 14 and 30Hz. Beta waves are prominent during states of motor control, long range

synchronization between brain areas, analytical problem solving, judgment, and decision making. Gamma waves occur between 30 and 60Hz and are involved in binding of different populations of neurons together into a network for the purpose of carrying out a certain cognitive or motor function, as well as in attention and memory. Because the skull and dermal layers attenuate waves in this frequency range, brain waves above 75-80Hz are difficult to detect and are often not used for stimuli response assessment.

[0088] However, the techniques and mechanisms of the present invention recognize that analyzing high gamma band (kappa-band: Above 60Hz) measurements, in addition to theta, alpha, beta, and low gamma band measurements, enhances neurological attention, emotional engagement and retention component estimates. In particular embodiments, EEG measurements including difficult to detect high gamma or kappa band measurements are obtained, enhanced, and evaluated. Subject and task specific signature sub-bands in the theta, alpha, beta, gamma and kappa bands are identified to provide enhanced response estimates. According to various embodiments, high gamma waves (kappa-band) above 80 Hz (typically detectable with sub-cranial EEG and/or magnetoencephalography) can be used in inverse model-based enhancement of the frequency responses to the stimuli.

[0089] Various embodiments of the present invention recognize that particular sub-bands within each frequency range have particular prominence during certain activities. A subset of the frequencies in a particular band is referred to herein as a sub-band. For example, a sub-band may include the 40-45Hz range within the gamma band. In particular embodiments, multiple sub-bands within the different bands are selected while remaining frequencies are band pass filtered. In particular embodiments, multiple sub-band responses may be enhanced, while the remaining frequency responses may be attenuated.

[0090] An information theory based band-weighting model is used for adaptive extraction of selective dataset specific, subject specific, task specific bands to enhance the effectiveness measure. Adaptive extraction may be performed using fuzzy scaling. Stimuli can be presented and enhanced measurements determined multiple times to determine the variation profiles across multiple presentations. Determining various profiles provides an enhanced assessment of the primary responses as well as the longevity (wear-out) of the marketing and entertainment stimuli. The synchronous response of multiple individuals to stimuli presented in concert is measured to determine an enhanced across subject synchrony measure of effectiveness. According to various embodiments, the synchronous response may be determined for multiple subjects residing in separate locations or for multiple subjects residing in the same location.

[0091] Although a variety of synthesis mechanisms are described, it should be recognized that any number of

mechanisms can be applied - in sequence or in parallel with or without interaction between the mechanisms.

[0092] Although intra-modality synthesis mechanisms provide enhanced significance data, additional cross-modality synthesis mechanisms can also be applied. A variety of mechanisms such as EEG, Eye Tracking, GSR, EOG, and facial emotion encoding are connected to a cross-modality synthesis mechanism. Other mechanisms as well as variations and enhancements on existing mechanisms may also be included. According to various embodiments, data from a specific modality can be enhanced using data from one or more other modalities. In particular embodiments, EEG typically makes frequency measurements in different bands like alpha, beta and gamma to provide estimates of significance. However, the techniques of the present invention recognize that significance measures can be enhanced further using information from other modalities.

[0093] For example, facial emotion encoding measures can be used to enhance the valence of the EEG emotional engagement measure. EOG and eye tracking saccadic measures of object entities can be used to enhance the EEG estimates of significance including but not limited to attention, emotional engagement, and memory retention. According to various embodiments, a cross-modality synthesis mechanism performs time and phase shifting of data to allow data from different modalities to align. In some examples, it is recognized that an EEG response will often occur hundreds of milliseconds before a facial emotion measurement changes. Correlations can be drawn and time and phase shifts made on an individual as well as a group basis. In other examples, saccadic eye movements may be determined as occurring before and after particular EEG responses. According to various embodiments, time corrected GSR measures are used to scale and enhance the EEG estimates of significance including attention, emotional engagement and memory retention measures.

[0094] Evidence of the occurrence or non-occurrence of specific time domain difference event-related potential components (like the DERP) in specific regions correlates with subject responsiveness to specific stimulus. According to various embodiments, ERP measures are enhanced using EEG time-frequency measures (ERP-SP) in response to the presentation of the marketing and entertainment stimuli. Specific portions are extracted and isolated to identify ERP, DERP and ERPSP analyses to perform. In particular embodiments, an EEG frequency estimation of attention, emotion and memory retention (ERPSP) is used as a co-factor in enhancing the ERP, DERP and time-domain response analysis.

[0095] EOG measures saccades to determine the presence of attention to specific objects of stimulus. Eye tracking measures the subject's gaze path, location and dwell on specific objects of stimulus. According to various embodiments, EOG and eye tracking is enhanced by measuring the presence of lambda waves (a neurophysiological index of saccade effectiveness) in the ongoing

EEG in the occipital and extra striate regions, triggered by the slope of saccade-onset to estimate the significance of the EOG and eye tracking measures. In particular embodiments, specific EEG signatures of activity such as slow potential shifts and measures of coherence in time-frequency responses at the Frontal Eye Field (FEF) regions that preceded saccade-onset are measured to enhance the effectiveness of the saccadic activity data.

[0096] According to various embodiments, facial emotion encoding uses templates generated by measuring facial muscle positions and movements of individuals expressing various emotions prior to the testing session. These individual specific facial emotion encoding templates are matched with the individual responses to identify subject emotional response. In particular embodiments, these facial emotion encoding measurements are enhanced by evaluating inter-hemispherical asymmetries in EEG responses in specific frequency bands and measuring frequency band interactions. The techniques of the present invention recognize that not only are particular frequency bands significant in EEG responses, but particular frequency bands used for communication between particular areas of the brain are significant. Consequently, these EEG responses enhance the EMG, graphic and video based facial emotion identification.

[0097] Integrated responses are generated at 621. According to various embodiments, the data communication device transmits data to the response integration using protocols such as the File Transfer Protocol (FTP), Hypertext Transfer Protocol (HTTP) along with a variety of conventional, bus, wired network, wireless network, satellite, and proprietary communication protocols. The data transmitted can include the data in its entirety, excerpts of data, converted data, and/or elicited response measures. According to various embodiments, data is sent using telecommunications, wireless, Internet, satellite, or any other communication mechanisms that is capable of conveying information from multiple subject locations for data integration and analysis. The mechanism may be integrated in a set top box, computer system, receiver, mobile device, etc.

[0098] In particular embodiments, the data communication device sends data to the response integration system. According to various embodiments, the response integration system combines analyzed and enhanced responses to the stimulus material while using information about stimulus material attributes. In particular embodiments, the response integration system also collects and integrates user behavioral and survey responses with the analyzed and enhanced response data to more effectively measure and track neuro-responses to stimulus materials. According to various embodiments, the response integration system obtains attributes such as requirements and purposes of the stimulus material presented.

[0099] Some of these requirements and purposes may

be obtained from a variety of databases. According to various embodiments, the response integration system also includes mechanisms for the collection and storage of demographic, statistical and/or survey based responses to different entertainment, marketing, advertising and other audio/visual/tactile/olfactory material. If this information is stored externally, the response integration system can include a mechanism for the push and/or pull integration of the data, such as querying, extraction, recording, modification, and/or updating.

[0100] The response integration system can further include an adaptive learning component that refines user or group profiles and tracks variations in the neuro-response data collection system to particular stimuli or series of stimuli over time. This information can be made available for other purposes, such as use of the information for presentation attribute decision making. According to various embodiments, the response integration system builds and uses responses of users having similar profiles and demographics to provide integrated responses at 621. In particular embodiments, stimulus and response data is stored in a repository at 623 for later retrieval and analysis.

[0101] According to various embodiments, various mechanisms such as the data collection mechanisms, the intra-modality synthesis mechanisms, cross-modality synthesis mechanisms, etc. are implemented on multiple devices. However, it is also possible that the various mechanisms be implemented in hardware, firmware, and/or software in a single system. Figure 7 provides one example of a system that can be used to implement one or more mechanisms. For example, the system shown in Figure 7 may be used to implement a data analyzer.

[0102] According to particular example embodiments, a system 700 suitable for implementing particular embodiments of the present invention includes a processor 701, a memory 703, an interface 711, and a bus 715 (e.g., a PCI bus). When acting under the control of appropriate software or firmware, the processor 701 is responsible for such tasks such as pattern generation. Various specially configured devices can also be used in place of a processor 701 or in addition to processor 701. The complete implementation can also be done in custom hardware. The interface 711 is typically configured to send and receive data packets or data segments over a network. Particular examples of interfaces the device supports include host bus adapter (HBA) interfaces, Ethernet interfaces, frame relay interfaces, cable interfaces, DSL interfaces, token ring interfaces, and the like.

[0103] In addition, various very high-speed interfaces may be provided such as fast Ethernet interfaces, Gigabit Ethernet interfaces, ATM interfaces, HSSI interfaces, POS interfaces, FDDI interfaces and the like. Generally, these interfaces may include ports appropriate for communication with the appropriate media. In some cases, they may also include an independent processor and, in some instances, volatile RAM. The independent processors may control such communications intensive tasks

as data synthesis.

[0104] According to particular example embodiments, the system 700 uses memory 703 to store data, algorithms and program instructions. The program instructions may control the operation of an operating system and/or one or more applications, for example. The memory or memories may also be configured to store received data and process received data.

[0105] Because such information and program instructions may be employed to implement the systems/methods described herein, the present invention relates to tangible, machine readable media that include program instructions, state information, etc. for performing various operations described herein. Examples of machine-readable media include, but are not limited to, magnetic media such as hard disks, floppy disks, and magnetic tape; optical media such as CD-ROM disks and DVDs; magneto-optical media such as optical disks; and hardware devices that are specially configured to store and perform program instructions, such as read-only memory devices (ROM) and random access memory (RAM). Examples of program instructions include both machine code, such as produced by a compiler, and files containing higher level code that may be executed by the computer using an interpreter.

[0106] Although the foregoing invention has been described in some detail for purposes of clarity of understanding, it will be apparent that certain changes and modifications may be practiced within the scope of the appended claims. Therefore, the present embodiments are to be considered as illustrative and not restrictive and the invention is not to be limited to the details given herein, but may be modified within the scope and equivalents of the appended claims.

Claims

1. A method, comprising:

integrating a stimulus material into a virtual reality environment;
 exposing a subject to the stimulus material in the virtual reality environment;
 collecting neuro-response data from the subject exposed to the stimulus material in the virtual reality environment; and
 analyzing the neuro-response data to determine the effectiveness of stimulus material in the virtual reality environment.

2. The method of claim 1 further comprising dynamically modifying at least one of the stimulus material in the virtual reality environment or the virtual reality environment based on the neuro-response data.

3. The method of claim 1 further comprising receiving interaction data from the subject to manipulate the

stimulus material.

4. The method of claim 1, wherein the stimulus material is one or more of a product, a product package, a service, an offering, a sign or a placard. 5
5. The method of claim 1, wherein neuro-response data includes electroencephalography (EEG) data.
6. The method of claim 1, wherein neuro-response data is collected using a plurality of modalities including central nervous system data, autonomic nervous system data and effector data. 10
7. The method of claim 1, wherein analyzing neuro-response data comprises obtaining target and distracter event related potential (ERP) measurements to determine differential measurements of ERP time domain components at multiple regions of the brain (DERP). 15 20
8. The method of claim 7, wherein analyzing neuro-response data further comprises obtaining event related time-frequency analysis of the differential response to assess the attention, emotion and memory retention (DERPSPs) across multiple frequency bands. 25
9. A system, comprising: 30
- an interface to receive a stimulus material for presentation to a subject;
 - a processor to integrate the stimulus material into a virtual reality environment, the processor to provide the stimulus material and the virtual reality environment to the subject using a display; 35
 - sensors to collect neuro-response data from the subject exposed to the stimulus material in the virtual reality environment; and 40
 - a data analyzer is to evaluate the neuro-response data from the subject to determine the effectiveness of stimulus material in the virtual reality environment. 45
10. The system of claim 9, wherein the processor is to dynamically modify at least one of the stimulus material in the virtual reality environment or the virtual reality environment based on the neuro-response data. 50
11. The system of claim 9, wherein the processor is to receive interaction data from the subject to manipulate the stimulus material. 55
12. The system of claim 9, wherein the sensors are to collect the neuro-response data using a plurality of modalities including central nervous system data,

autonomic nervous system data and effector data.

13. The system of claim 9, the data analyzer is to obtain target and distracter event related potential (ERP) measurements to determine differential measurements of ERP time domain components at multiple regions of the brain (DERP).
14. The system of claim 13, the data analyzer is to obtain event related time-frequency analysis of the differential response to assess the attention, emotion and memory retention (DERPSPs) across multiple frequency bands.
15. A computer program which, when executed by a computer causes to at least:
- integrate a stimulus material into a virtual reality environment;
 - expose a subject to the stimulus material in the virtual reality environment;
 - collect neuro-response data from the subject exposed to the stimulus material in the virtual reality environment; and
 - analyze the neuro-response data to determine the effectiveness of stimulus material in the virtual reality environment.

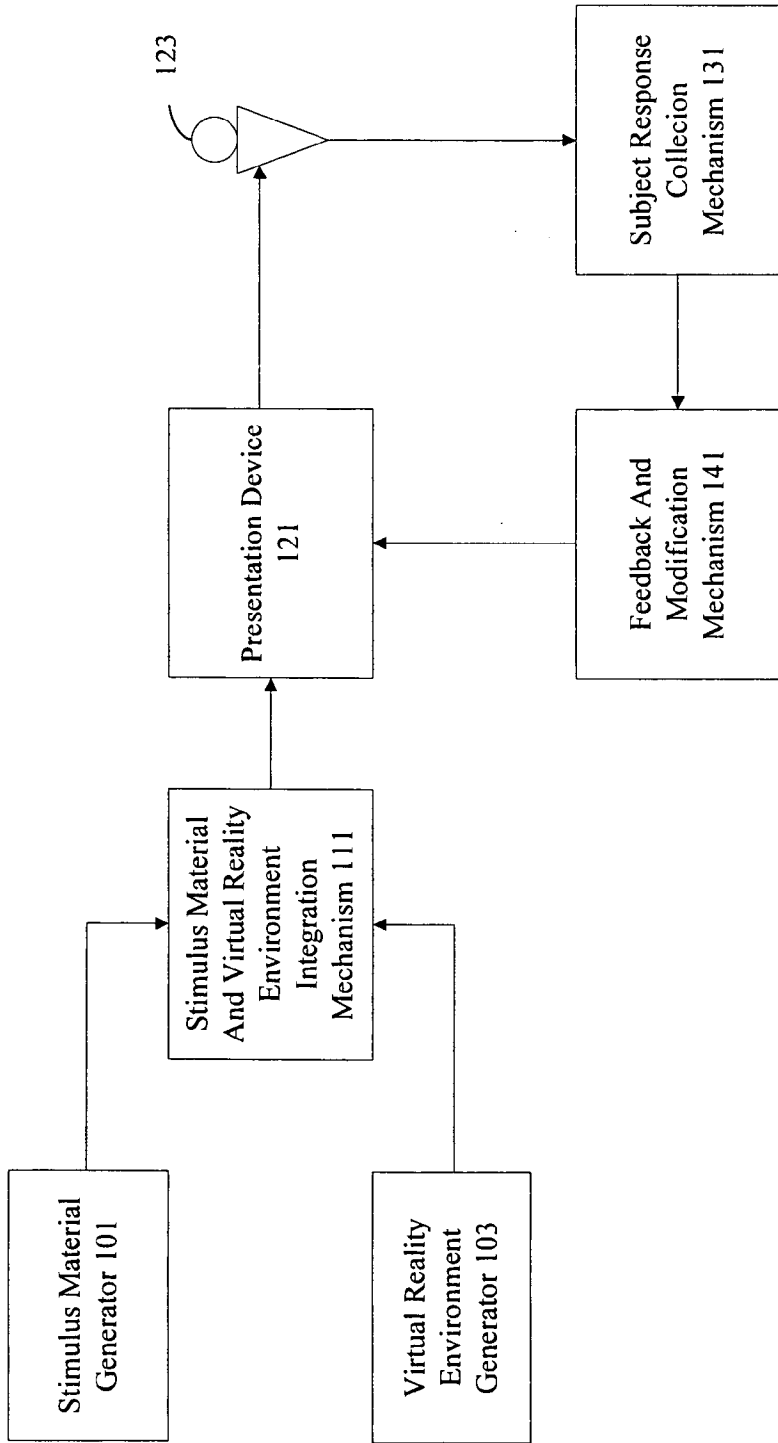

Figure 1A

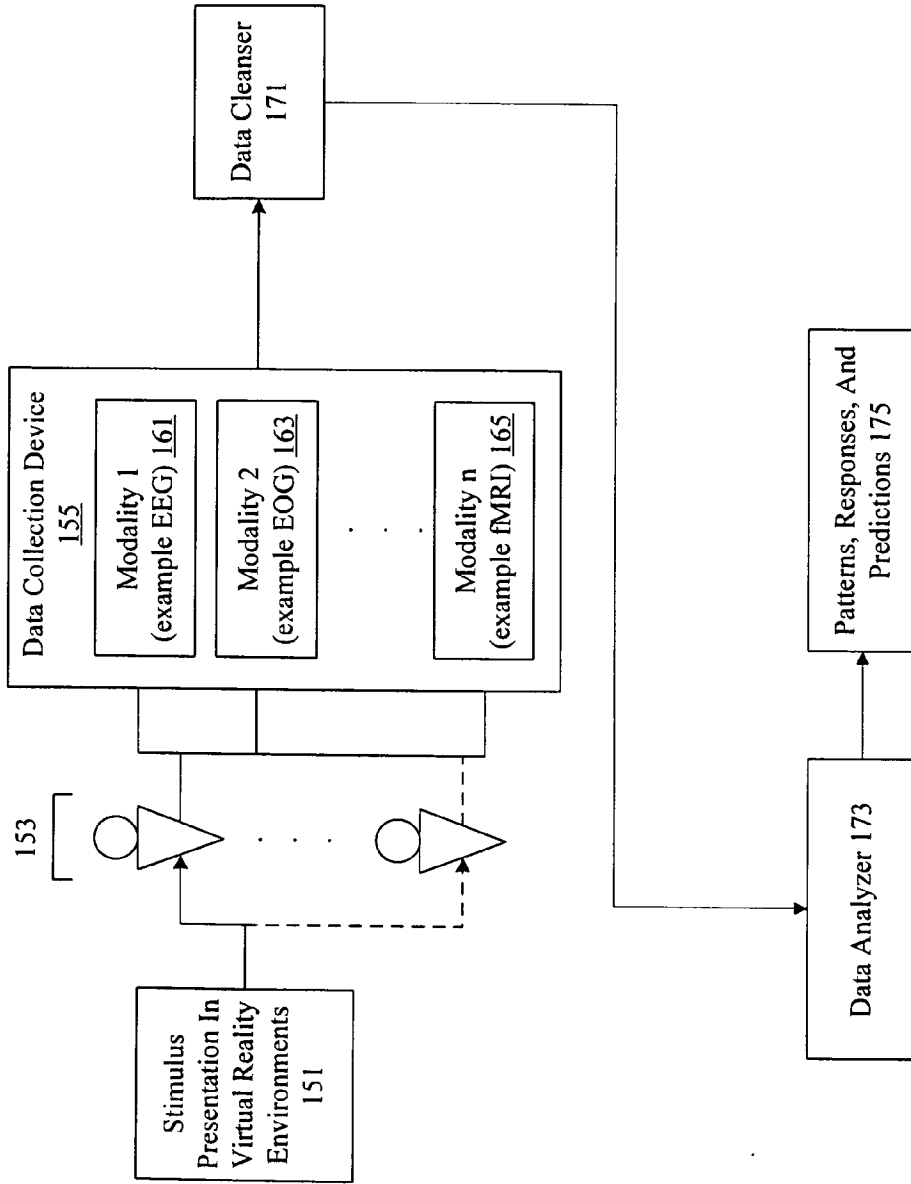

Figure 1B

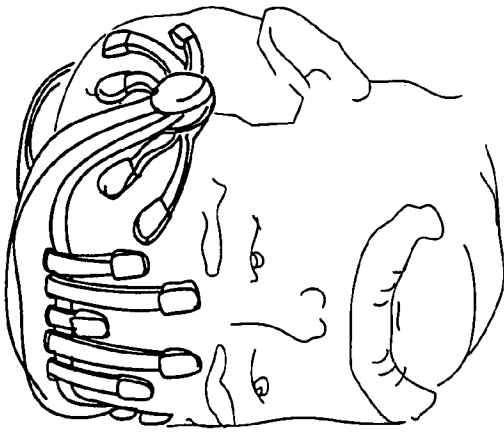

Figure 2A

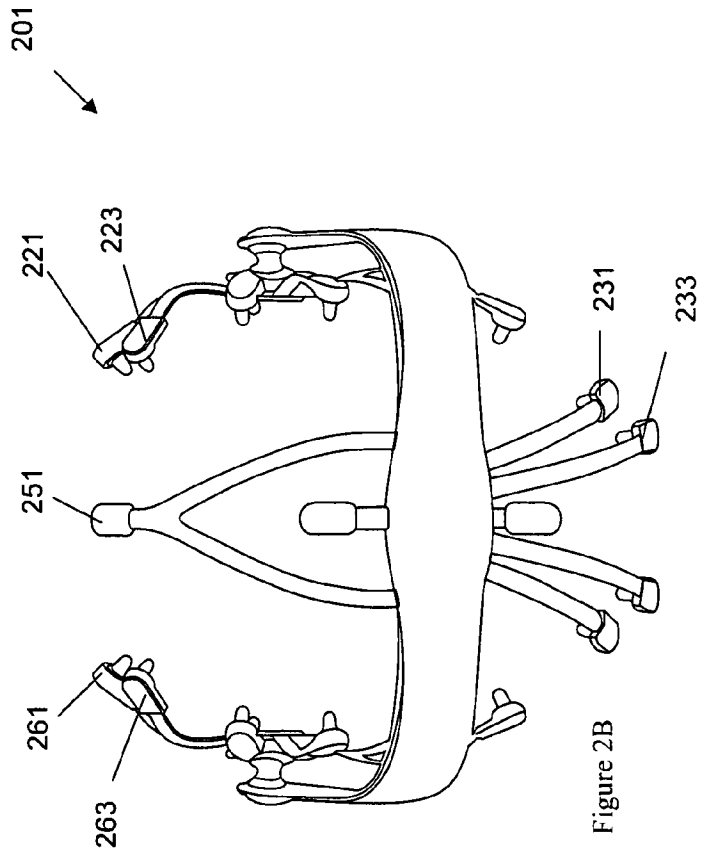

Figure 2B

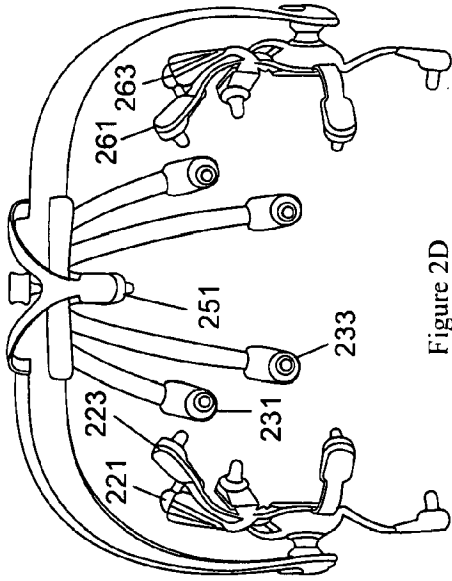

Figure 2D

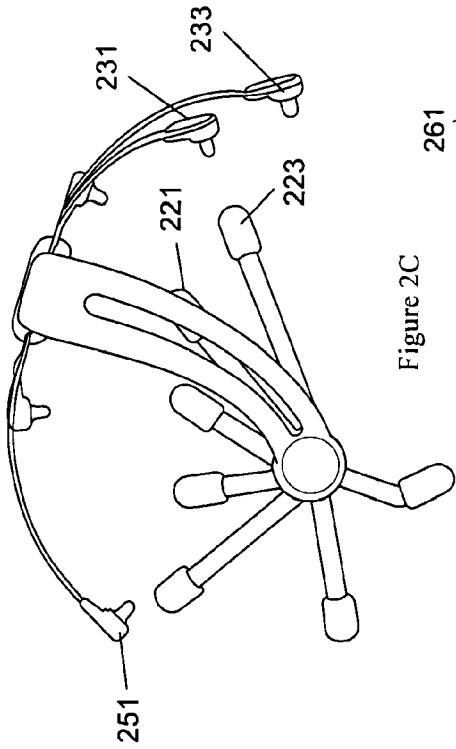

Figure 2C

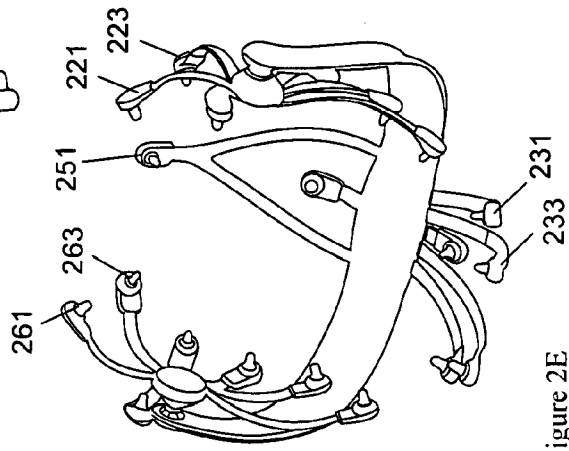

Figure 2E

Dataset Data Model 301			
Experiment Name 303	Client Attributes 305	Subject Pool 307	Logistics Information 309
			Stimulus Material 311
			...

Subject Attributes Data Model 315	
Subject Name 317	Demographic Attributes 319
	Contact Information 321
	...

Data Collection Data Model 337		
Recording Attributes 339	Equipment Attributes 341	Modalities Recorded 343
		Data Storage Attributes 345
		...

Preset Query Data Model 349		
Query Name 351	Accessed Data Collection 353	Access Security Attributes 355
		Refresh Attributes 357
		...

Figure 3

Subject Attributes Queries 415			
Location 417	Demographic Attributes 419	Time Information 421	Location Information 423
			...

Response Assessment Queries 437			
Attention Score 439	Emotion Score 441	Retention Score 443	Effectiveness Score 445
			...

Figure 4

Client Assessment Summary Reports 501			
Effectiveness 503	Component Assessment 505	Distributed Neuro-Response Data Collection 507	...
Client Cumulative Reports 511			
Media Grouped 513	Campaign Grouped 515	Time/Location Grouped 517	...
Industry Cumulative And Syndicated Reports 521			
Aggregate Assessment 523	Top Performers 525	Bottom Performers 527	Outliers 529 Trend 531 ...

Figure 5

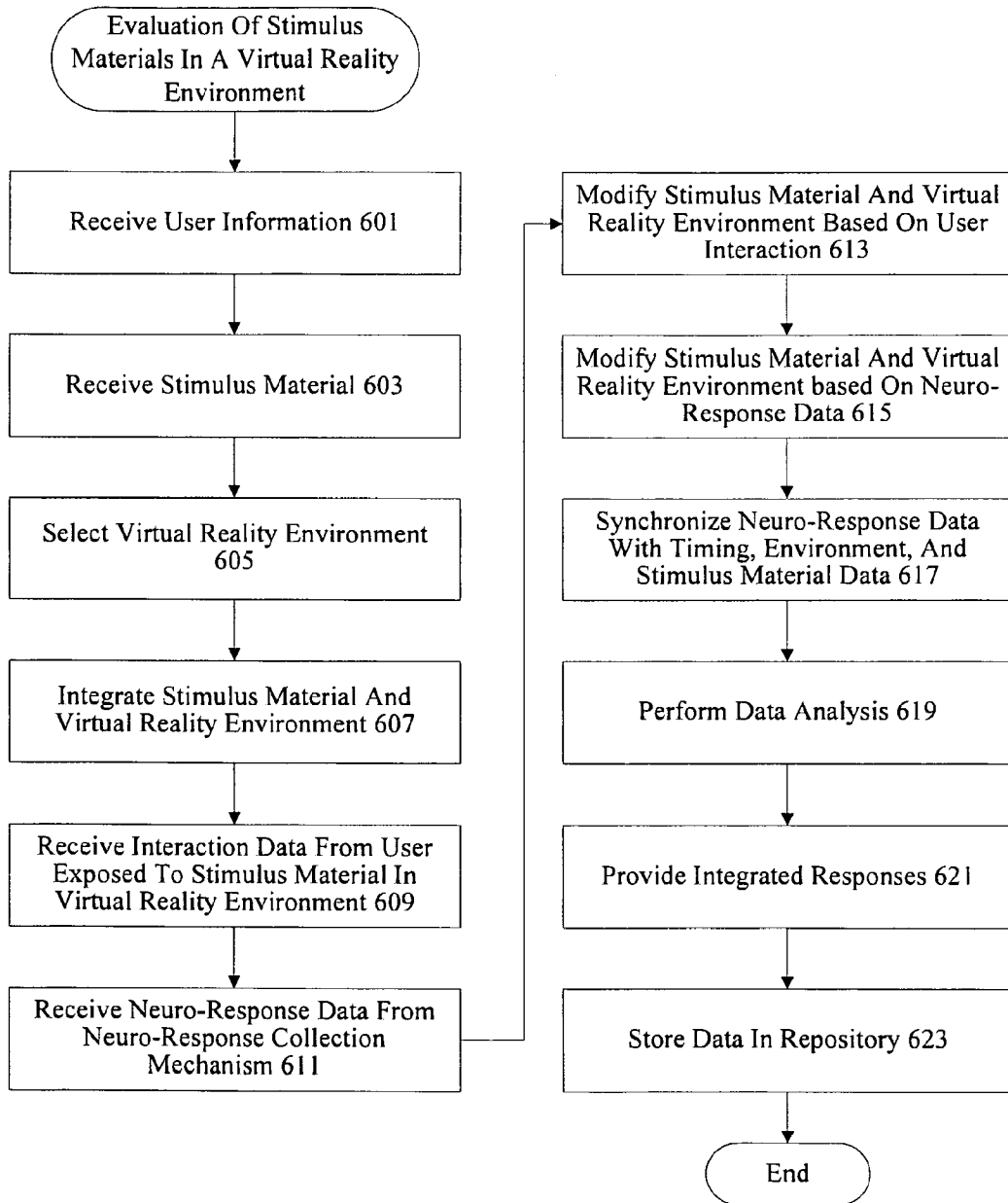

Figure 6

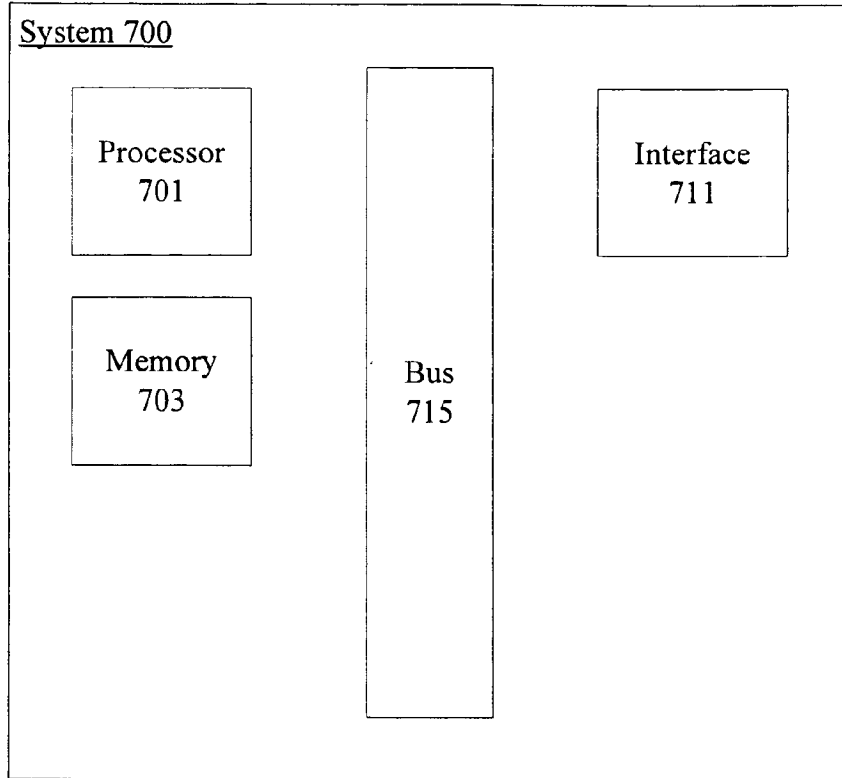

Figure 7

专利名称(译)	神经反应评估了虚拟现实环境中的刺激		
公开(公告)号	EP2417904A9	公开(公告)日	2012-06-06
申请号	EP2011006553	申请日	2011-08-09
[标]申请(专利权)人(译)	尼尔森(美国)有限公司		
申请(专利权)人(译)	尼尔森公司 (美国) 有限责任公司		
当前申请(专利权)人(译)	尼尔森公司 (美国) 有限责任公司		
[标]发明人	PRADEEP ANANTHA KNIGHT ROBERT T GURUMOORTHY RAMACHANDRAN		
发明人	PRADEEP, ANANTHA KNIGHT, ROBERT T. GURUMOORTHY, RAMACHANDRAN		
IPC分类号	A61B5/00		
CPC分类号	A61B3/112 A61B3/113 A61B5/04009 A61B5/0402 A61B5/04842 A61B5/0496 A61B5/055 A61B5/162 A61B5/163 G06Q30/02 G06Q30/0242 G06Q30/0244		
优先权	12/853197 2010-08-09 US		
其他公开文献	EP2417904A2 EP2417904A3		
外部链接	Espacenet		

摘要(译)

系统在诸如市场过道，商店货架，陈列室地板等虚拟现实环境中呈现诸如产品，产品包，显示器，服务，产品等的刺激材料。通过虚拟现实环境输出给用户的感觉体验引出用户互动。用户活动和响应用于修改营销材料和/或虚拟现实环境。从用户收集包括脑电图（EEG）数据的神经反应数据，以评估营销材料在虚拟现实环境中的有效性。在特定示例中，神经响应数据用于修改呈现给用户的营销材料和虚拟现实环境。

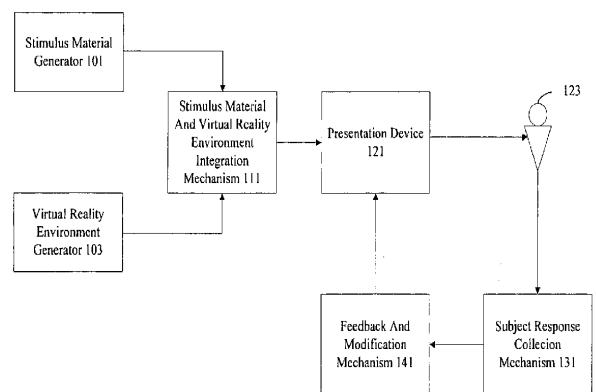

Figure 1A