



(11) **EP 1 766 551 B1**

(12) **EUROPEAN PATENT SPECIFICATION**

(45) Date of publication and mention of the grant of the patent:  
**20.02.2013 Bulletin 2013/08**

(21) Application number: **05756911.3**

(22) Date of filing: **04.07.2005**

(51) Int Cl.:  
**G06T 7/00 (2006.01) A61B 5/00 (2006.01)**

(86) International application number:  
**PCT/IL2005/000707**

(87) International publication number:  
**WO 2006/003658 (12.01.2006 Gazette 2006/02)**

(54) **3D THERMAL BREAST CANCER DETECTOR**

**3D THERMISCH BRUSTKREBSDETEKTOR**

**DETECTEUR THERMIQUE DE CANCER DU SEIN 3D**

(84) Designated Contracting States:  
**AT BE BG CH CY CZ DE DK EE ES FI FR GB GR HU IE IS IT LI LT LU LV MC NL PL PT RO SE SI SK TR**

(30) Priority: **07.07.2004 US 586162 P**

(43) Date of publication of application:  
**28.03.2007 Bulletin 2007/13**

(73) Proprietor: **Real imaging**  
**71520 Lod (IL)**

(72) Inventor: **ARNON, Boaz**  
**71945 Lod (IL)**

(74) Representative: **Denemeyer & Associates S.A.**  
**55, rue des Bruyères**  
**1274 Howald (LU)**

(56) References cited:  
**DE-A1- 10 150 918 US-A- 4 967 276**  
**US-A- 6 023 637 US-A1- 2001 046 316**  
**US-A1- 2002 173 723**

- **HAI XIAO ET AL: "Multispectral three-dimensional digital infrared thermal imaging", OPTICAL ENGINEERING SPIE USA, vol. 42, no. 4, April 2003 (2003-04), pages 906-911, XP002614080, ISSN: 0091-3286**
- **SMITH ANDREW P ET AL: "Emerging technologies in breast cancer detection.", RADIOLOGY MANAGEMENT , 1 July 2004 (2004-07-01), XP002614081, Retrieved from the Internet: URL:http://www.hologic.com/data/WB-001\_E mergTech\_08-06.pdf [retrieved on 2010-12-15]**
- **KEYSERLINGK R ET AL: "Historical Perspectives, Current Applications, and Future Considerations", IEEE ENGINEERING IN MEDICINE AND BIOLOGY MAGAZINE, IEEE SERVICE CENTER, PISACATAWAY, NJ, US, vol. 19, no. 3, 1 May 2000 (2000-05-01), pages 30-41, XP011085045, ISSN: 0739-5175, DOI: 10.1109/51.844378**
- **XIANGYANG JU ET AL: "3D thermography imaging standardization technique for inflammation diagnosis", PROCEEDINGS OF THE SPIE - THE INTERNATIONAL SOCIETY FOR OPTICAL ENGINEERING SPIE-INT. SOC. OPT. ENG. USA, vol. 5640, no. 1, 10 January 2005 (2005-01-10), pages 266-273, XP002614079, ISSN: 0277-786X**

Note: Within nine months of the publication of the mention of the grant of the European patent in the European Patent Bulletin, any person may give notice to the European Patent Office of opposition to that patent, in accordance with the Implementing Regulations. Notice of opposition shall not be deemed to have been filed until the opposition fee has been paid. (Art. 99(1) European Patent Convention).

**EP 1 766 551 B1**

**Description**

## FIELD OF THE INVENTION

**[0001]** The present invention relates to a system and method for 3D imaging thermographic imaging, and more particularly to 3D thermographic imaging of a portion of a human body.

## BACKGROUND OF THE INVENTION

**[0002]** U.S. Patent No, 6,442,419 is believed to represent the current state of the art,

**[0003]** Hai Xiao et al., "Multispectral three-dimensional digital infrared thermal imaging", Optical Engineering SPINE USA, vol. 42, no. 4, April 2003 (2003-04), pages 906-911, disclose a system which has both capabilities of 3D surface geometrical profiling and 2D temperature distribution measurement of a human body. A structured-light machine vision system performs the 3D surface mapping using a pair of fibers to project an interference pattern onto the human skin, and a solid-state thermal camera is used to generate thermogram. These two subsystems measure a 2D temperature distribution and a 3D geometrical surface profile which are digitally stored in the computer separately.

**[0004]** Smith et al, "Emerging technologies in breast cancer detection", Radiology Management 2004 Jul-Aug, vol, 26, no. 4 (2004), pages 16-24, summarizes several technologies for breast cancer detection, including Bioelectric Imaging, Breast Thermography, Computer-Aided Detection, Contrast-Enhanced Mammography, Full-Field Digital Mammography, Magnetic Resonance Imaging, Near Infrared Optical Imaging, Nuclear Imaging, Tomosynthesis and 3D Imaging, and Ultrasound.

## SUMMARY OF THE INVENTION

**[0005]** The present invention seeks to provide a system and method for combination of 3D non-thermographic and thermographic imaging of a portion of a human body, preferably for medical diagnostic purposes.

**[0006]** There is thus provided in accordance with a preferred embodiment of the present invention a system for 3D thermographic imaging of a portion of a human body including non-thermographic image data acquisition functionality operative to acquire non-thermographic image data for at least a portion of a human body, thermographic image data acquisition functionality operative to acquire thermographic image data for at least a part of the at least one portion of the human body containing at least one object and a combine image generator operative to combine the non-thermographic and thermographic image data to provide a visually sensible three-dimensional output indicating the location and orientation of the at least one object within the at least a portion of the human body.

**[0007]** In accordance with a preferred embodiment of the present invention the system for 3D thermographic imaging of a portion of a human body also includes a housing containing the non-thermographic image data acquisition functionality and the thermographic image data acquisition functionality. Additionally or alternatively, the system for 3D thermographic imaging of a portion of a human body also includes a positioning device operative to reposition the housing.

**[0008]** In accordance with another preferred embodiment of the present invention the non-thermographic image data and the thermographic image data include at least one two-dimensional image. Additionally or alternatively, the non-thermographic image data and the thermographic image data include at least one three-dimensional image.

**[0009]** In accordance with yet another preferred embodiment of the present invention the non-thermographic image data acquisition functionality includes a stills camera or a digital camera. Optionally and preferably, the stills camera includes a black-and-white stills camera or a color stills camera. Additionally or alternatively, the digital camera includes CCD or CMOS. In accordance with a further preferred embodiment of the present invention the non-thermographic image data acquisition functionality also includes a polarizer. Alternatively, the non-thermographic image data acquisition functionality may also include a color filter. In accordance with another further preferred embodiment of the present invention the thermographic image data acquisition functionality is sensitive to infra-red wavelengths.

**[0010]** In accordance with a still further preferred embodiment of the present invention the object in the portion of a human body includes a tumor. Preferably, the tumor includes cancerous tumor.

**[0011]** In accordance with a preferred embodiment of the present invention the combined image generator includes a computing device operative to combine the non-thermographic and thermographic image data to provide the visibly sensible three-dimensional output, a display for displaying the visibly sensible three-dimensional output and a communications network operative to connect the computing device to the display. Preferably, the system also includes a communications network operative to connect the non-thermographic image data acquisition functionality and the thermographic image data acquisition functionality to the combined image generator. Preferably, the computing device includes a PC or a PDA and the display includes of at least one LCD, at least one CRT or a plasma screen. As a further alternative, the display may include two LCDs or two CRTs packaged together in an eyeglasses structure. Preferably, the display is operative to display a pointer.

**[0012]** In accordance with another preferred embodiment of the present invention the communications networks include at least one of intranet, Internet, Blue-Tooth communications network, cellular communications network, infra-red communications network and

radio frequency communications network.

**[0013]** In accordance with yet another preferred embodiment of the present invention the system for 3D thermographic imaging of a portion of a human body also includes a positioning device operative to reposition the non-thermographic image data acquisition functionality or the thermographic image data acquisition functionality. Additionally or alternatively, the system also includes a positioning device operative to reposition the human body.

**[0014]** There is also provided in accordance with another preferred embodiment of the present invention a method for 3D thermographic imaging of a portion of a human body including acquiring non-thermographic image data for at least a portion of a human body, acquiring thermographic image data for at least a part of the at least one portion of the human body containing at least one object and combining the non-thermographic and thermographic image data to provide a visually sensible three-dimensional output indicating the location and orientation of the at least one object within the at least a portion of the human body.

**[0015]** In accordance with a preferred embodiment of the present invention the non-thermographic image data and the thermographic image data include at least one two-dimensional image. Additionally or alternatively, the non-thermographic image data and the thermographic image data include at least one three-dimensional image.

**[0016]** In accordance with another preferred embodiment of the present invention the acquiring non-thermographic image data includes acquiring first non-thermographic image data in a first relative position of the human body and at least one non-thermographic image data acquisition functionality and acquiring at least second non-thermographic image data in at least a second relative position of the human body and at least one non-thermographic image data acquisition functionality.

**[0017]** In accordance with yet another preferred embodiment of the present invention the acquiring thermographic image data includes acquiring first thermographic image data in a first relative position of the human body and at least one thermographic image data acquisition functionality and acquiring at least second thermographic image data in at least a second relative position of the human body and at least one thermographic image data acquisition functionality.

**[0018]** In accordance with a further preferred embodiment of the present invention the at least second relative position is configured by repositioning the human body. Alternatively, the at least second relative position is configured by repositioning the at least one non-thermographic image data acquisition functionality or the at least one thermographic image data acquisition functionality. As a further alternative, the first relative position is configured by a first the non-thermographic image data acquisition functionality or by a first thermographic image data acquisition functionality and the at least second relative position is configured by at least a second the non-

thermographic image data acquisition functionality or by at least a second thermographic image data acquisition functionality.

**[0019]** In accordance with another further preferred embodiment of the present invention the non-thermographic image data acquisition functionality or the thermographic image data acquisition functionality is enclosed within a housing, and the at least second relative position is configured by repositioning the housing. Alternatively, the first relative position is configured by a first the non-thermographic image data acquisition functionality or a first thermographic image data acquisition functionality enclosed within a first housing, and the at least second relative position is configured by at least a second the non-thermographic image data acquisition functionality or at least a second thermographic image data acquisition functionality enclosed within at least a second housing.

**[0020]** In accordance with yet a further preferred embodiment of the present invention the combining includes computing a non-thermographic three-dimensional model of the non-thermographic image data, computing a thermographic three-dimensional model of the thermographic image data, combining the non-thermographic three-dimensional model and the thermographic three-dimensional model to provide the visually sensible three-dimensional output and displaying the visually sensible three-dimensional output.

**[0021]** In accordance with a still further preferred embodiment of the present invention the computing a non-thermographic three-dimensional model of the non-thermographic image data also includes computing spatial data of the non-thermographic three-dimensional model. Preferably, the computing spatial data of the non-thermographic three-dimensional model includes computing the X, Y and Z coordinates of the portion of the human body. Additionally or alternatively, the computing a non-thermographic three-dimensional model of the non-thermographic image data also includes obtaining information relating to the color, hue or tissue texture of the portion of the human body.

**[0022]** In accordance with another preferred embodiment of the present invention the computing a thermographic three-dimensional model of the non-thermographic image data also includes computing spatial temperature data of the non-thermographic three-dimensional model. Preferably, the computing spatial data of the non-thermographic three-dimensional model includes computing the temperature of the portion of the human body along the X, Y and Z coordinates.

**[0023]** In accordance with yet another preferred embodiment of the present invention the combining the non-thermographic three-dimensional model and the thermographic three-dimensional model includes substantially positioning the non-thermographic three-dimensional model and the thermographic three-dimensional model in parallel manner. Preferably, the substantially positioning the non-thermographic three-dimen-

sional model and the thermographic three-dimensional model includes substantially positioning a marker. Additionally or alternatively the substantially positioning the non-thermographic three-dimensional model and the thermographic three-dimensional model includes substantially positioning X, Y and Z coordinates of the non-thermographic three-dimensional model and the thermographic three-dimensional model.

**[0024]** In accordance with still another preferred embodiment of the present invention the displaying the visually sensible three-dimensional output also includes displaying a pointer. Additionally or alternatively the displaying the visually sensible three-dimensional output also includes displaying sectional views of the visually sensible three-dimensional output.

**[0025]** In accordance with a further preferred embodiment of the present invention the method also includes extracting information from the visibly sensible three-dimensional output, and preferably also includes displaying the extracted information. Additionally or alternatively, the method also includes comparing the visibly sensible three-dimensional output to at least one visibly sensible three-dimensional model.

#### BRIEF DESCRIPTION OF THE DRAWINGS

**[0026]** The present invention will be understood and appreciated more fully from the following detailed description, taken in conjunction with the drawings in which:

Fig. 1 is a simplified pictorial illustration of a 3D non-thermographic and thermographic imaging system operative in accordance with a preferred embodiment of the present invention;

Figs. 2A-2E are simplified pictorial illustrations of five alternative embodiments of one stage of a method in accordance with a preferred embodiment of the present invention;

Figs. 3A-3E are simplified pictorial illustrations of five alternative embodiments of another stage of a method in accordance with a preferred embodiment of the present invention;

Fig. 4 is a flow chart illustration of the computing stage of a method in accordance with a preferred embodiment of the present invention;

Fig. 5 is a simplified pictorial illustration of an initial step of the computing stage of a method in accordance with a preferred embodiment of the present invention;

Fig. 6 is a simplified pictorial illustration of another step of the computing stage of a method in accordance with a preferred embodiment of the present invention; and

Fig. 7 is a simplified pictorial illustration of the final step of the computing stage of a method in accordance with a preferred embodiment of the present invention.

#### DETAILED DESCRIPTION OF PREFERRED EMBODIMENTS

**[0027]** Reference is now made to Fig. 1, which illustrates a system for 3D non-thermographic and thermographic imaging of a portion of a human body, in accordance with a preferred embodiment of the present invention. The system may be used as a diagnostic tool, for example for medical diagnosis such as diagnosis of tumors, and specifically in the diagnosis of cancerous breast tumors.

**[0028]** As seen in Fig. 1, a body part 10 of a person 12 is located in front of an imaging device 14. The person 12, may be standing, sitting or in any other suitable position relative to imaging device 14. Person 12 may initially be positioned or later be repositioned relative to imaging device 14 by positioning device 15, which typically comprises a platform moving on a rail, by force of an engine, or by any other suitable force. Additionally, a tumor 16 may exist in body part 10 of person 12. Typically, body part 10 comprises a breast, and tumor 16 comprises a breast tumor such as a cancerous tumor.

**[0029]** In accordance with a preferred embodiment of the present invention, person 12 may be wearing a clothing garment 18, such as a shirt. Preferably, clothing garment 18 may be non-penetrable or partially penetrable to visible wavelengths such as 400-700 nanometers, and may be penetrable to wavelengths that are longer than visible wavelengths, such as IR wavelengths. Additionally, a reference mark 20 may be located close to person 12, preferably directly on the body of person 12 and in close proximity to body part 10. Optionally and preferably, reference mark 20 is directly attached to body part 10. Reference mark 20 may typically comprise a piece of material, a mark drawn on person 12 or any other suitable mark, as described hereinbelow.

**[0030]** Imaging device 14 typically comprise at least one non-thermographic imaging system 22 that can sense at least visible wavelengths and at least one thermographic imaging system 24 which is sensitive to infra-red (IR) wavelengths, typically in the range of as 3-5 micrometer and/or 8-12 micrometer. Typically imaging systems 22 and 24 are capable of sensing reference mark 20 described hereinabove.

**[0031]** Optionally, a polarizer 25 may be placed in front of non-thermographic imaging system 22. As a further alternative, a color filter 26, which may block at least a portion of the visible wavelengths, may be placed in front of non-thermographic imaging system 22.

**[0032]** Typically, at least one non-thermographic imaging system 22 may comprise a black-and-white or color stills camera, or a digital camera such as CCD or CMOS. Additionally, at least one non-thermographic imaging system 22 may comprise a plurality of imaging elements, each of may be a three-dimensional imaging a plurality of imaging elements, each of which may be a three-dimensional imaging element.

**[0033]** Optionally, imaging device 14 may be repositioned

tioned relative to person 12 by positioning device 27. As a further alternative, each of imaging systems 22 and 24 may also be repositioned relative to person 12 by at least one positioning device 28. Positioning device 27 may comprise an engine, a lever or any other suitable force, and may also comprise a rail for moving imaging device 14 thereon. Preferably, repositioning device 28 may be similarly structured.

**[0034]** Data acquired by non-thermographic imaging system 22 and thermographic imaging system 24 is output to a computing device 30 via a communications network 32, and is typically analyzed and processed by an algorithm running on the computing device. The resulting data may be displayed on at least one display device 34, which is preferably connected to computing device 30 via a communications network 36. Computing device 30 typically comprises a PC, a PDA or any other suitable computing device. Communications networks 32 and 36 typically comprise a physical communications network such as an internet or intranet, or may alternatively comprise a wireless network such as a cellular network, IR communication network, a radio frequency (RF) communications network, a blue-tooth (BT) communications network or any other suitable communications network.

**[0035]** In accordance with a preferred embodiment of the present invention display 34 typically comprises a screen, such as an LCD screen, a CRT screen or a plasma screen. As a further alternative display 34 may comprise at least one visualizing device comprising two LCDs or two CRTs, located in front of a user's eyes and packaged in a structure similar to that of eye-glasses. Preferably, display 34 also displays a pointer 38, which is typically movable along the X, Y and Z axes of the displayed model and may be used to point to different locations or elements in the displayed data.

**[0036]** Reference is now made to Figs. 2A-4, which illustrated various stages in method of 3D non-thermographic and thermographic imaging of a portion of a human body, in accordance with a preferred embodiment of the present invention.

**[0037]** As seen in Fig. 2A, person 12 comprising body part 10 is located on a positioning device 15 in front of an imaging device 14, in a first position 40 relative to the imaging device. First image data of body part 10 is acquired by at least one non-thermographic imaging system 22, optionally through polarizer 25 or as an alternative option through color filter 26. Additionally, at least second image data of body part 10 is acquired by at least one non-thermographic imaging system 22, such that body part 10 is positioned in at least a second position 42 relative to imaging device 14.

**[0038]** The second relative position 42 may be configured by repositioning person 12 using positioning device 15 as seen in Fig. 2A, by repositioning imaging device 14 using positioning device 27 as seen in Fig. 2B or by repositioning non-thermographic imaging system 22 using positioning device 28 as seen in Fig. 2C. As a further alternative, the second relative position 42 may be con-

figured by using two separate imaging devices 14 as seen in Fig. 2D or two separate non-thermographic imaging systems 22 as seen in Fig. 2E.

**[0039]** In a further stage of the method in accordance with a preferred embodiment of the present invention, person 12 comprising body part 10 is located on a positioning device 15 in front of an imaging device 14, in a first position 44 relative to the imaging device. First thermographic image data of body part 10 is acquired by at least one thermographic imaging system 24. Additionally, at least second thermographic image data of body part 10 is acquired by at least one thermographic imaging system 24, such that body part 10 is positioned in at least a second position 42 relative to imaging device 14.

**[0040]** The second relative position 46 may be configured by repositioning person 12 using positioning device 15 as seen in Fig. 3A, by repositioning imaging device 14 using positioning device 27 as seen in Fig. 3B, or by repositioning thermographic imaging system 24 using positioning device 28 as seen in Fig. 3C. As a further alternative, the second relative position 46 may be configured by using two separate imaging devices 14 as seen in Fig. 3D or two separate thermographic imaging systems 24 as seen in Fig. 3E.

**[0041]** It will be appreciated that the non-thermographic image data acquisition described in Figs. 2A-2E may be performed before, after or concurrently with the thermographic image data acquisition described in Figs. 3A-3E.

**[0042]** Image data of body part 10 may be acquired by thermographic imaging system 24, by separately imaging a plurality of narrow strips of the complete image of body part 10. Alternatively, the complete image of body part 10 is acquired by thermographic imaging system, and the image is sampled in a plurality of narrow strips or otherwise shaped portions for processing. As a further alternative, the image of body part 10 may be performed using different exposure times.

**[0043]** The thermographic and non-thermographic image data obtained from imaging device 14 is analyzed and processed by computing device 30 as illustrated in Fig. 4.

**[0044]** In stage 50, image data acquired from non-thermographic imaging system 22 is processed by computing device 30 to build a non-thermographic three-dimensional model of body part 10 of person 12, using algorithms and methods that are well known in the art, such as the method described in U.S. Patent No. 6,442,419 which is hereby incorporated by reference as if fully set forth herein. The non-thermographic three-dimensional model, preferably includes spatial information, typically the X, Y and Z coordinates of the body part 10, as well as the location of reference marker 20. Additionally, the non-thermographic three-dimensional model preferably includes information relating to the color, hue and tissue texture of body part 10. An exemplary non-thermographic three-dimensional model and the process of building such a model are illustrated in Fig. 5.

**[0045]** Thermographic image data acquired from thermographic imaging system 24 is processed by computing device 30 in stage 52 to build a thermographic three-dimensional model of body part 10 of person 12, using algorithms and methods that are well known in the art, such as the method described in U.S. Patent No. 6,442,419 which is hereby incorporated by reference as if fully set forth herein. The thermographic three-dimensional model preferably includes spatial temperature information, typically the X, Y and Z coordinates of the temperature of body part 10 and of reference marker 20. An exemplary thermographic three-dimensional model and the process of building such a model are illustrated in Fig. 6.

**[0046]** It is appreciated that the thermographic three-dimensional model may be built before, after or concurrently with the non-thermographic three-dimensional model.

**[0047]** The three-dimensional models built in stages 50 and 52 as described hereinabove are combined into a single three-dimensional model in stage 54. Correct positioning of the two models in the combined three-dimensional model may be achieved by accurately positioning reference marker 20 in the two models, by comparing X, Y and Z coordinates or using any other suitable method. An exemplary combined three-dimensional model as built in stage 54 is illustrated in Fig. 7.

**[0048]** In stage 36, computing device 30 extracts information included in the combined three-dimensional model, such as information regarding temperature, temperature changes in a certain point and a comparison of temperatures in different points in body part 10. Additionally, computing device 30 may extract, compute and display a comparison of size or temperature between body part 10 and another body part of person 12, such as the two breasts of person 12.

**[0049]** In an additional or alternative stage 58, the computing device 30 may compare and display differences between a plurality of three-dimensional models of the same body part 10 of a person 12, the plurality of models being based on data acquired at a plurality of different time points. Typically, the information compared, computed and displayed includes information about temperature, dimensions such as length, width, height and depth, shape, volume, color, hue and tissue texture. The information may be displayed graphically or textually, and may be described as a change in percentage or in absolute value.

**[0050]** As shown in stage 60, the output of any of stages 54, 56 and 58 is displayed on display 34. Pointer 38 is also displayed, and may be used to point to sections or elements of the displayed model, along any of the X, Y and Z coordinates. Optionally and preferably, an algorithm is provided to facilitate the display of sectional views of the three-dimensional model or of specific tissue layers of the modeled body part 10.

**[0051]** It will be appreciated by persons skilled in the art that the present invention is not limited to what has

been particularly shown and described hereinabove. Rather the scope of the present invention includes both combinations and subcombinations of the various features described hereinabove as well as modifications and variations thereof as would occur to a person of skill in the art upon reading the foregoing specification and which are not in the prior art.

## 10 Claims

1. A system for determining presence or absence of a thermally distinguishable object (16) in a living body (12), the system comprising;

a combined image generator (30) configured for combining: (i) non-thermographic three-dimensional data of a three-dimensional tissue region in the living body (12), said non-thermographic data including coordinates of a reference marker (20) located on or close to the body (12); with (ii) thermographic two-dimensional data of said tissue region, said thermographic data including coordinates of the same reference marker (20); by co-positioning the coordinates of the reference marker (20) of the non-thermographic data and the coordinates of the reference marker (20) of the thermographic data;

so as to generate three-dimensional temperature data associated with said three-dimensional tissue region and to provide a visually sensible three-dimensional output indicating the location and/or orientation of the object (16) within the body (12), thereby to determine the presence or absence of the thermally distinguishable object (16).

2. The system of claim 1, further comprising non-thermographic image data acquisition functionality (22) configured for acquiring said non-thermographic three-dimensional data, including said reference marker (20).
3. The system according to any of claims 1 and 2, further comprising thermographic image data acquisition functionality (24) configured for acquiring said thermographic two-dimensional data, including said reference marker (20).
4. The system of claim 3, wherein said non-thermographic image data acquisition functionality (22) and said thermographic image data acquisition functionality (24) are oriented generally parallel to each other.
5. The system of claim 3, further comprising a housing containing said non-thermographic image data acquisition functionality (22) and said thermographic

image data acquisition functionality (24).

- 6. The system of claim 1, further comprising a positioning device (15) operative to reposition said housing.
- 7. The system of claim 1, wherein said combined image generator (30) comprises a computing device configured for calculating said location and/or orientation of the thermally distinguishable object (16) in the three-dimensional tissue region, based on said three-dimensional temperature data.
- 8. The system of claim 7, further comprising a display (34), and wherein said computing device (30) is in communication with said display (34) and is configured for transmitting said visibly sensible three-dimensional output indicating said location and/or orientation to said display (34).
- 9. The system of claim 8, further comprising a communication network (32) configured for establishing said communication between said computing device (30) and said display (34).
- 10. The system of claim 1, further comprising a comparing functionality (30) configured for comparing said three-dimensional temperature data to at least one three-dimensional model.
- 11. The system of claim 7, wherein said computing device (30) is configured for computing a non-thermographic three-dimensional model, and computing spatial data of said non-thermographic three-dimensional model so as to generate spatial data pertaining to the location and/or orientation of the thermally distinguishable object (16) within the living body (12).
- 12. The system of claim 11, wherein said computing device (30) is configured for computing spatial temperature data of said non-thermographic three-dimensional model.
- 13. The system of claim 1, wherein said non-thermographic three-dimensional data comprise a combination of a plurality of two-dimensional images.
- 14. The system of claim 2, wherein said non-thermographic image data acquisition functionality (22) comprises a stills camera or a digital camera.
- 15. The system of claim 2, wherein said non-thermographic image data acquisition functionality (22) comprises a plurality of cameras configured and positioned for acquiring a plurality of non-thermographic two-dimensional datasets from a plurality of perspective viewpoints with respect to the surface of said three-dimensional tissue region.

5  
10  
15  
20  
25  
30  
35  
40  
45  
50  
55

- 16. The system of claim 15, wherein said non-thermographic image data acquisition functionality (22) comprises a combiner configured for combining said plurality of non-thermographic two-dimensional datasets so as to form said non-thermographic three-dimensional data.
- 17. The system of claim 3, wherein said thermographic image data acquisition functionality (24) comprises a plurality of infrared cameras configured and positioned for acquiring a plurality of thermographic two-dimensional datasets from a plurality of perspective viewpoints with respect to the surface of said three-dimensional tissue region.
- 18. The system of claim 17, wherein said combined image generator (30) is configured for combining said non-thermographic three-dimensional data with each thermographic two-dimensional dataset.
- 19. The system of claim 1, wherein said thermally distinguishable object (16) comprises a tumor.
- 20. The system of claim 19, wherein said tumor (16) comprises a cancerous tumor.
- 21. The system of claim 8, wherein said display (34) comprises two LCDs or two CRTs packaged together in an eye-glasses structure.
- 22. The system of claim 8, wherein said display (34) is operative to display a pointer (38).
- 23. The system of claim 3, further comprising a positioning device (15) operative to reposition said non-thermographic image data acquisition functionality. (22) or said thermographic image data acquisition functionality (24).
- 24. The system of claim 3, further comprising a communications network (32) configured for establishing said communication between at least two of said non-thermographic image data acquisition functionality (22), said thermographic image data acquisition functionality (24) and said combined image generator (30).
- 25. The system of claim 1, further comprising a positioning device (15) operative to reposition the living body (12).
- 26. A method of determining presence or absence of a thermally distinguishable object (16) in a living body (12), the method comprising:

combining: (i) non-thermographic three-dimensional data of a three-dimensional tissue region in the living body (12), said non-thermographic

- data including coordinates of a reference marker (20) located on or close to the body (12); with (ii) thermographic two-dimensional data of said tissue region, said thermographic data including coordinates of the same reference marker (20); by co-positioning the coordinates of the reference marker (20) of the non-thermographic data and the coordinates of the reference marker (20) of the thermographic data; so as to generate three-dimensional temperature data associated with said three-dimensional tissue region and to provide a visually sensible three-dimensional output indicating the location and/or orientation of the object (16) within the body (12), thereby determining the presence or absence of the thermally distinguishable object (16).
27. The method of claim 26, further comprising using said three-dimensional temperature data for determining the location and/or orientation of the thermally distinguishable object (16) in the three-dimensional tissue region.
28. The method of claim 26, further comprising comparing said three-dimensional temperature data to at least one three-dimensional model.
29. The method of claim 26, wherein said non-thermographic three-dimensional data are obtained by combining a plurality of two-dimensional images.
30. The method of claim 26, wherein said non-thermographic three-dimensional data comprise a three-dimensional image acquired using a visible light camera.
31. The method of claim 26, further comprising acquiring said non-thermographic three-dimensional data using at least one non-thermographic image data acquisition functionality (22).
32. The method of claim 31, wherein said acquiring said non-thermographic three-dimensional data comprises a plurality of sequential data acquisition steps, and the method further comprises repositioning at least one of said data acquisition functionality and the living body (12) between successive data acquisition steps.
33. The method of claim 32, wherein said plurality of sequential data acquisition steps comprises a first two-dimensional data acquisition step performed at a first perspective view and a second two-dimensional data acquisition step performed at a second perspective view, and the method further comprises combining two-dimensional data from said first step and said second step so as to form said non-thermographic three-dimensional data.
34. The method of claim 31, wherein said acquiring said non-thermographic three-dimensional data comprises simultaneously acquiring non-thermographic two-dimensional datasets from a plurality of perspective viewpoints with respect to the surface of said three-dimensional tissue region, and the method further comprises combining said plurality of non-thermographic two-dimensional datasets so as to form said non-thermographic three-dimensional data.
35. The method of claim 26, further comprising acquiring said thermographic two-dimensional data, using at least one thermographic image data acquisition functionality (24).
36. The method of claim 35, wherein said acquiring said thermographic two-dimensional data comprises a plurality of sequential data acquisition steps, and the method further comprises repositioning at least one of said data acquisition functionality (24) and the living body (12) between successive data acquisition steps.
37. The method of claim 35, wherein said acquiring said thermographic two-dimensional data comprises simultaneously acquiring thermographic two-dimensional datasets from a plurality of perspective viewpoints with respect to the surface of said three-dimensional tissue region, and the method further comprises combining each thermographic two-dimensional dataset with said non-thermographic three-dimensional data.
38. The method of claim 36, wherein said combining is performed such that data acquired at each thermographic two-dimensional data acquisition step is combined with said non-thermographic three-dimensional data.
39. The method of claim 26, wherein said combining comprises computing a non-thermographic three-dimensional model, and computing spatial data of said non-thermographic three-dimensional model so as to generate spatial data pertaining to the location and/or orientation of the thermally distinguishable object (16) within the living body (12).
40. The method of claim 39, wherein said combining comprises computing spatial temperature data of said non-thermographic three-dimensional model.

#### Patentansprüche

1. System zum Bestimmen des Vorhandenseins oder

Nicht-Vorhandenseins eines thermisch unterscheidbaren Objekts (16) in einem lebenden Körper (12), wobei das System umfasst:

- einen Kombinationsbildgenerator (30), der konfiguriert ist, um zu kombinierten: (i) nicht-thermographische dreidimensionale Daten einer dreidimensionalen Geweberegion im lebenden Körpers (12), wobei die nicht-thermographischen Daten Koordinaten eines Referenzmarkers (20) enthalten, der sich am Körper (12) oder nahe diesem befindet; mit (ii) thermographischen zweidimensionalen Daten der Geweberegion, wobei die thermographischen Daten Koordinaten des gleichen Referenzmarkers (20) enthalten; durch Cositionieren der Koordinaten des Referenzmarkers (20) der nicht-thermographischen Daten und der Koordinaten des Referenzmarkers (20) der thermographischen Daten;
- um dreidimensionale Temperaturdaten zu generieren, die mit der dreidimensionalen Geweberegion assoziiert sind, und um eine visuell empfindliche dreidimensionale Ausgabe bereitzustellen, die die Position und/oder die Ausrichtung des Objekts (16) innerhalb des Körpers (12) indiziert, um dadurch das Vorhandensein oder Nicht-Vorhandensein des thermisch unterscheidbaren Objekts (16) zu bestimmen.
2. System nach Anspruch 1, ferner umfassend eine Erfassungsfunktion (22) für nicht-thermographische Bilddaten, die konfiguriert ist, um die nicht-thermographischen dreidimensionalen Daten, enthaltend den Referenzmarker (20), zu erfassen.
  3. System nach einem der Ansprüche 1 und 2, ferner umfassend eine Erfassungsfunktion (24) für thermographische Bilddaten, die konfiguriert ist, um die thermographischen zweidimensionalen Daten, enthaltend den Referenzmarker (20), zu erfassen.
  4. System nach Anspruch 3, wobei die Erfassungsfunktion (22) für nicht-thermographische Bilddaten und die Erfassungsfunktion (24) für thermographische Bilddaten im Allgemeinen parallel zueinander ausgerichtet sind.
  5. System nach Anspruch 3, ferner umfassend ein Gehäuse, das die Erfassungsfunktion (22) für nicht-thermographische Bilddaten und die Erfassungsfunktion (24) für thermographische Bilddaten enthält.
  6. System nach Anspruch 1, ferner umfassend eine Positioniervorrichtung (15), die betreibbar ist, um das Gehäuse zu repositionieren.
  7. System nach Anspruch 1, wobei der Kombinationsbildgenerator (30) eine Rechenvorrichtung umfasst, die konfiguriert ist, um die Position und/oder die Ausrichtung des thermisch unterscheidbaren Objekts (16) in der dreidimensionalen Geweberegion auf Basis der dreidimensionalen Temperaturdaten zu berechnen.
  8. System nach Anspruch 7, ferner umfassend eine Anzeige (34), und wobei die Rechenvorrichtung (30) mit der Anzeige (34) in Verbindung steht und konfiguriert ist, um die visuell empfindliche dreidimensionale Ausgabe, die die Position und/oder die Ausrichtung indiziert, an die Anzeige (34) zu übertragen.
  9. System nach Anspruch 8, ferner umfassend ein Kommunikationsnetzwerk (32), das konfiguriert ist, um die Kommunikation zwischen der Rechenvorrichtung (30) und der Anzeige (34) herzustellen.
  10. System nach Anspruch 1, ferner umfassend eine Vergleichsfunktion (30), die konfiguriert ist, um die dreidimensionalen Temperaturdaten mit zumindest einem dreidimensionalen Modell zu vergleichen.
  11. System nach Anspruch 7, wobei die Rechenvorrichtung (30) konfiguriert ist, um ein nicht-thermographisches dreidimensionales Modell zu berechnen, und um Raumdaten des nicht-thermographischen dreidimensionalen Modells zu berechnen, um Raumdaten in Bezug auf die Position und/oder die Ausrichtung des thermisch unterscheidbaren Objekts (16) innerhalb des lebenden Körpers (12) zu generieren.
  12. System nach Anspruch 11, wobei die Rechenvorrichtung (30) konfiguriert ist, um Raumtemperaturdaten des nicht-thermographischen dreidimensionalen Modells zu berechnen.
  13. System nach Anspruch 1, wobei die nicht-thermographischen dreidimensionalen Daten eine Kombination einer Mehrzahl von zweidimensionalen Bildern umfassen.
  14. System nach Anspruch 2, wobei die Erfassungsfunktion (22) für nicht-thermographische Bilddaten eine Standbildkamera oder eine Digitalkamera umfasst.
  15. System nach Anspruch 2, wobei die Erfassungsfunktion (22) für nicht-thermographische Bilddaten eine Mehrzahl von Kameras umfasst, die konfiguriert und positioniert sind, um eine Mehrzahl von nicht-thermographischen zweidimensionalen Datensätzen aus einer Mehrzahl von perspektivischen Standpunkten in Bezug auf die Oberfläche der dreidimensionalen Geweberegion zu erfassen.

16. System nach Anspruch 15, wobei die Erfassungsfunktionalität (22) für nicht-thermographische Bilddaten einen Kombinator umfasst, der konfiguriert ist, um die Mehrzahl von nicht-thermographischen zweidimensionalen Datensätzen zu kombinieren, um die nicht-thermographischen dreidimensionalen Daten zu bilden. 5
17. System nach Anspruch 3, wobei die Erfassungsfunktion (24) für thermographische Bilddaten eine Mehrzahl von Infrarotkameras umfasst, die konfiguriert und positioniert sind, um eine Mehrzahl von thermographischen zweidimensionalen Datensätzen aus einer Mehrzahl von perspektivischen Standpunkten in Bezug auf die Oberfläche der dreidimensionalen Geweberegion zu erfassen. 10
18. System nach Anspruch 17, wobei der Kombinationsbildgenerator (30) konfiguriert ist, um die nicht-thermographischen dreidimensionalen Daten mit jedem thermographischen zweidimensionalen Datensatz zu kombinieren. 15
19. System nach Anspruch 1, wobei das thermisch unterscheidbare Objekt (16) einen Tumor umfasst. 20
20. System nach Anspruch 19, wobei der Tumor (16) einen krebsartigen Tumor umfasst. 25
21. System nach Anspruch 8, wobei die Anzeige (34) zwei LCDs oder zwei CRTs umfasst, die gemeinsam in eine Brillenstruktur gepackt sind. 30
22. System nach Anspruch 8, wobei die Anzeige (34) betreibbar ist, um einen Zeiger (38) anzuzeigen. 35
23. System nach Anspruch 3, ferner umfassend eine Positioniervorrichtung (15), die betreibbar ist, um die Erfassungsfunktion (22) für nicht-thermographische Bilddaten oder die Erfassungsfunktion (24) für thermographische Bilddaten zu repositionieren. 40
24. System nach Anspruch 3, ferner umfassend ein Kommunikationsnetzwerk (32), das konfiguriert ist, um die Kommunikation zwischen zumindest zwei der Erfassungsfunktion (22) für nicht-thermographische Bilddaten, der Erfassungsfunktion (24) für thermographische Bilddaten und des Kombinationsbildgenerators (30) herzustellen. 45
25. System nach Anspruch 1, ferner umfassend eine Positioniervorrichtung (15), die betreibbar ist, um den lebenden Körper (12) zu repositionieren. 50
26. Verfahren zum Bestimmen des Vorhandenseins oder Nicht-Vorhandenseins eines thermisch unterscheidbaren Objekts (16) in einem lebenden Körper (12), wobei das Verfahren umfasst:
- das Kombinieren von: (i) nicht-thermographischen dreidimensionalen Daten einer dreidimensionalen Geweberegion im lebenden Körpers (12), wobei die nicht-thermographischen Daten Koordinaten eines Referenzmarkers (20) enthalten, der sich am Körper (12) oder nahe diesem befindet; mit (ii) thermographischen zweidimensionalen Daten der Geweberegion, wobei die thermographischen Daten Koordinaten des gleichen Referenzmarkers (20) enthalten; durch Copositionieren der Koordinaten des Referenzmarkers (20) der nicht-thermographischen Daten und der Koordinaten des Referenzmarkers (20) der thermographischen Daten;
- um dreidimensionale Temperaturdaten zu generieren, die mit der dreidimensionalen Geweberegion assoziiert sind, und um eine visuell empfindliche dreidimensionale Ausgabe bereitzustellen, die die Position und/oder die Ausrichtung des Objekts (16) innerhalb des Körpers (12) indiziert, um dadurch das Vorhandensein oder Nicht-Vorhandensein des thermisch unterscheidbaren Objekts (16) zu bestimmen.
27. Verfahren nach Anspruch 26, ferner umfassend das Verwenden der dreidimensionalen Temperaturdaten, um die Position und/oder die Ausrichtung des thermisch unterscheidbaren Objekts (16) in der dreidimensionalen Geweberegion zu bestimmen.
28. Verfahren nach Anspruch 26, ferner umfassend das Vergleichen der dreidimensionalen Temperaturdaten mit zumindest einem dreidimensionalen Modell.
29. Verfahren nach Anspruch 26, wobei die nicht-thermographischen dreidimensionalen Daten durch Kombinieren einer Mehrzahl von zweidimensionalen Bildern erhalten werden.
30. Verfahren nach Anspruch 26, wobei die nicht-thermographischen dreidimensionalen Daten ein dreidimensionales Bild umfassen, die unter Verwendung einer VIS-Kamera erfasst wurde.
31. Verfahren nach Anspruch 26, ferner umfassend das Erfassen der nichtthermographischen dreidimensionalen Daten unter Verwendung zumindest einer Erfassungsfunktion (22) für nicht-thermographischen Bilddaten. 55
32. Verfahren nach Anspruch 31, wobei das Erfassen der nicht-thermographischen dreidimensionalen Daten eine Mehrzahl von sequenziellen Datenerfassungsschritten umfasst, und wobei das Verfahren ferner das Repositionieren zumindest eines der Datenerfassungsfunktion und des lebenden Körpers (12) zwischen aufeinanderfolgenden Datenerfäs-

sungsschritten umfasst.

33. Verfahren nach Anspruch 32, wobei die Mehrzahl von sequenziellen Datenerfassungsschritten einen ersten Erfassungsschritt von zweidimensionalen Daten, der in einer ersten perspektivischen Ansicht durchgeführt wird, und einen zweiten Erfassungsschritt von zweidimensionalen Daten, der in einer zweiten perspektivischen Ansicht durchgeführt wird, umfasst, und wobei das Verfahren ferner das Kombinieren von zweidimensionalen Daten aus dem ersten Schritt und dem zweiten Schritt umfasst, um die nicht-thermographischen dreidimensionalen Daten zu bilden.
34. Verfahren nach Anspruch 31, wobei das Erfassen der nicht-thermographischen dreidimensionalen Daten das gleichzeitige Erfassen von nicht-thermographischen zweidimensionalen Datensätzen aus einer Mehrzahl von perspektivischen Standpunkten in Bezug auf die Oberfläche der dreidimensionalen Geweberegion umfasst, und wobei das Verfahren ferner das Kombinieren der Mehrzahl von nicht-thermographischen zweidimensionalen Datensätzen umfasst, um die nicht-thermographischen dreidimensionalen Daten zu bilden.
35. Verfahren nach Anspruch 26, ferner umfassend das Erfassen der thermographischen zweidimensionalen Daten unter Verwendung zumindest einer Erfassungsfunktion (24) für thermographischen Bilddaten.
36. Verfahren nach Anspruch 35, wobei das Erfassen der thermographischen zweidimensionalen Daten eine Mehrzahl von sequenziellen Datenerfassungsschritten umfasst, und wobei das Verfahren ferner das Repositionieren zumindest eines der Datenerfassungsfunktion (24) und des lebenden Körpers (12) zwischen aufeinanderfolgenden Datenerfassungsschritten umfasst.
37. Verfahren nach Anspruch 35, wobei das Erfassen der thermographischen zweidimensionalen Daten das gleichzeitige Erfassen von thermographischen zweidimensionalen Datensätzen aus einer Mehrzahl von perspektivischen Standpunkten in Bezug auf die Oberfläche der dreidimensionalen Geweberegion umfasst, und wobei das Verfahren ferner das Kombinieren jedes thermographischen zweidimensionalen Datensatzes mit den nicht-thermographischen dreidimensionalen Daten umfasst.
38. Verfahren nach Anspruch 36, wobei das Kombinieren derart durchgeführt wird, dass Daten, die in jedem Erfassungsschritt von thermographischen zweidimensionalen Daten erfasst werden, mit den nicht-thermographischen dreidimensionalen Daten

kombiniert werden.

39. Verfahren nach Anspruch 26, wobei das Kombinieren das Berechnen eines nicht-thermographischen dreidimensionalen Modells und das Berechnen von Raumdaten des nicht-thermographischen dreidimensionalen Modells umfasst, um Raumdaten in Bezug auf die Position und/oder die Ausrichtung des thermisch unterscheidbaren Objekts (16) innerhalb des lebenden Körpers (12) zu generieren.
40. Verfahren nach Anspruch 39, wobei das Kombinieren das Berechnen von Raumtemperaturdaten des nicht-thermographischen dreidimensionalen Modells umfasst.

### Revendications

1. Système de détermination de la présence ou de l'absence d'un objet thermiquement perceptible (16) dans un corps vivant (12), ledit système comprenant :
- un générateur d'images combinées (30) configuré pour combiner : (i) des données non thermographiques en trois dimensions d'une zone de tissu en trois dimensions dudit corps vivant (12), lesdites données non thermographiques comprenant les coordonnées d'un marqueur de référence (20) situé sur ou près dudit corps (12) ; avec (ii) les données thermographiques en deux dimensions de ladite zone de tissu, lesdites données thermographiques comprenant les coordonnées du même marqueur de référence (20) ; en co-positionnant les coordonnées dudit marqueur de référence (20) desdites données non thermographiques avec les coordonnées dudit marqueur de référence (20) desdites données thermographiques ; de façon à générer des données de température en trois dimensions associées à ladite zone de tissu en trois dimensions, et pour fournir un résultat en trois dimensions visuellement sensible qui indique l'emplacement et/ou l'orientation dudit objet (16) dans ledit corps (12), afin de déterminer la présence ou l'absence dudit objet thermiquement perceptible (16).
2. Système selon la revendication 1, qui comprend en outre une fonctionnalité d'acquisition de données d'images non thermographiques (22) configurée pour acquérir lesdites données non thermographiques en trois dimensions, y compris ledit marqueur de référence (20).
3. Système selon l'une quelconque des revendications 1 et 2, qui comprend en outre une fonctionnalité d'ac-

- quisition de données d'images thermographiques (24) configurée pour acquérir lesdites données thermographiques en deux dimensions, y compris ledit marqueur de référence (20).
4. Système selon la revendication 3, dans lequel ladite fonctionnalité d'acquisition de données d'images non thermographiques (22) et ladite fonctionnalité d'acquisition de données d'images thermographiques (24) sont orientées de manière généralement parallèle l'une à l'autre.
5. Système selon la revendication 3, qui comprend en outre un boîtier qui contient ladite fonctionnalité d'acquisition de données d'images non thermographiques (22) et ladite fonctionnalité d'acquisition de données d'images thermographiques (24).
6. Système selon la revendication 1, qui comprend en outre un dispositif de positionnement (15) capable de repositionner ledit boîtier.
7. Système selon la revendication 1, dans lequel ledit générateur d'images combinées (30) comprend un dispositif de calcul configuré pour calculer ledit emplacement et/ou ladite orientation dudit objet thermiquement perceptible (16) dans ladite zone de tissu en trois dimensions, sur la base desdites données de température en trois dimensions.
8. Système selon la revendication 7, qui comprend en outre un afficheur (34), et dans lequel ledit dispositif de calcul (30) est en communication avec ledit afficheur (34) et est configuré pour transmettre ledit résultat en trois dimensions visuellement sensible qui indique ledit emplacement et/ou ladite orientation audit afficheur (34).
9. Système selon la revendication 8, qui comprend en outre un réseau de communication (32) configuré pour établir ladite communication entre ledit dispositif de calcul (30) et ledit afficheur (34).
10. Système selon la revendication 1, qui comprend en outre une fonctionnalité de comparaison (30) configurée pour comparer lesdites données de température en trois dimensions avec au moins un modèle en trois dimensions.
11. Système selon la revendication 7, dans lequel ledit dispositif de calcul (30) est configuré pour calculer un modèle non thermographique en trois dimensions, et pour calculer les données spatiales dudit modèle en trois dimensions non thermographique de façon à générer des données spatiales relatives à l'emplacement et/ou à l'orientation dudit objet thermiquement perceptible (16) au sein dudit corps vivant (12).
12. Système selon la revendication 11, dans lequel ledit dispositif de calcul (30) est configuré pour calculer les données de température spatiales dudit modèle non thermographique en trois dimensions.
13. Système selon la revendication 1, dans lequel lesdites données non thermographiques en trois dimensions comprennent une combinaison d'une pluralité d'images en deux dimensions.
14. Système selon la revendication 2, dans lequel ladite fonctionnalité d'acquisition de données d'images non thermographiques (22) comprend un appareil photo numérique.
15. Système selon la revendication 2, dans lequel ladite fonctionnalité d'acquisition de données d'images non thermographiques (22) comprend une pluralité d'appareils photo configurés et positionnés pour acquérir une pluralité d'ensembles de données non thermographiques en deux dimensions depuis une pluralité de perspectives par rapport à la surface de ladite zone de tissu en trois dimensions.
16. Système selon la revendication 15, dans lequel ladite fonctionnalité d'acquisition de données d'images non thermographiques (22) comprend un combineur configuré pour combiner ladite pluralité d'ensembles de données non thermographiques en deux dimensions de façon à former lesdites données non thermographiques en trois dimensions.
17. Système selon la revendication 3, dans lequel ladite fonctionnalité d'acquisition de données d'images thermographiques (24) comprend une pluralité de caméras infrarouges configurées et positionnées pour acquérir une pluralité d'ensembles de données thermographiques en deux dimensions depuis une pluralité de perspectives par rapport à la surface de ladite zone de tissu en trois dimensions.
18. Système selon la revendication 17, dans lequel ledit générateur d'images combinées (30) est configuré pour combiner lesdites données non thermographiques en trois dimensions avec chaque ensemble de données thermographique en deux dimensions.
19. Système selon la revendication 1, dans lequel ledit objet thermiquement perceptible (16) comprend une tumeur.
20. Système selon la revendication 19, dans lequel ladite tumeur (16) comprend une tumeur cancéreuse.
21. Système selon la revendication 8, dans lequel ledit afficheur (34) comprend deux LCD ou deux CRT contenus ensemble dans une structure à lunettes.

22. Système selon la revendication 8, dans lequel ledit afficheur (34) est capable d'afficher un pointeur (38).
23. Système selon la revendication 3, qui comprend en outre un dispositif de positionnement (15) capable de repositionner ladite fonctionnalité d'acquisition de données d'images non thermographiques (22) ou ladite fonctionnalité d'acquisition de données d'images thermographiques (24).
24. Système selon la revendication 3, qui comprend en outre un réseau de communication (32) configuré pour établir ladite communication entre au moins deux de ladite fonctionnalité d'acquisition de données d'images non thermographiques (22), de ladite fonctionnalité d'acquisition de données d'images thermographiques (24) et dudit générateur d'images combinées (30).
25. Système selon la revendication 1, qui comprend en outre un dispositif de positionnement (15) capable de repositionner ledit corps vivant (12).
26. Procédé de détermination de la présence ou de l'absence d'un objet thermiquement perceptible (16) dans un corps vivant (12), le procédé comprenant :
- la combinaison ; (i) de données non thermographiques en trois dimensions d'une zone de tissu en trois dimensions au sein dudit corps vivant (12), lesdites données non thermographiques comprenant les coordonnées d'un marqueur de référence (20) situé sur ou près dudit corps (12) ; avec (ii) les données thermographiques en deux dimensions de ladite zone de tissu, lesdites données thermographiques comprenant les coordonnées du même marqueur de référence (20) ; en co-positionnant les coordonnées dudit marqueur de référence (20) desdites données non thermographiques avec les coordonnées dudit marqueur de référence (20) desdites données thermographiques ; de façon à générer des données de température en trois dimensions associées à ladite zone de tissu en trois dimensions et à fournir un résultat en trois dimensions visuellement sensible qui indique l'emplacement et/ou l'orientation dudit objet (16) au sein dudit corps (12), afin de déterminer ainsi la présence ou l'absence dudit objet thermiquement perceptible (16).
27. Procédé selon la revendication 26, qui comprend en outre l'utilisation desdites données de température en trois dimensions pour déterminer l'emplacement et/ou l'orientation dudit objet thermiquement perceptible (16) au sein de ladite zone de tissu en trois dimensions.
28. Procédé selon la revendication 26, qui comprend en outre la comparaison desdites données de température en trois dimensions avec au moins un modèle en trois dimensions.
29. Procédé selon la revendication 26, dans lequel lesdites données non thermographiques en trois dimensions sont obtenues en combinant une pluralité d'images en deux dimensions.
30. Procédé selon la revendication 26, dans lequel lesdites données non thermographiques en comprennent une image en trois dimensions acquise à l'aide d'un appareil photo à lumière visible.
31. Procédé selon la revendication 26, qui comprend en outre l'acquisition desdites données non thermographiques en trois dimensions à l'aide d'au moins une fonctionnalité d'acquisition de données d'images non thermographiques (22).
32. Procédé selon la revendication 31, dans lequel ladite acquisition desdites données non thermographiques en trois dimensions comprend une pluralité d'étapes d'acquisition de données séquentielles, et le procédé comprend en outre le repositionnement d'au moins l'un de ladite fonctionnalité d'acquisition de données et dudit corps vivant (12) entre des étapes d'acquisition de données successives.
33. Procédé selon la revendication 32, dans lequel ladite pluralité d'étapes d'acquisition de données séquentielles comprend une première étape d'acquisition de données en deux dimensions effectuée selon une première perspective, et une seconde étape d'acquisition de données en deux dimensions effectuée selon une seconde perspective, et le procédé comprend en outre la combinaison des données en deux dimensions de ladite première étape et de ladite seconde étape de façon à former lesdites données non thermographiques en trois dimensions.
34. Procédé selon la revendication 31, dans lequel ladite acquisition desdites données non thermographiques en trois dimensions comprend l'acquisition simultanée d'ensembles de données non thermographiques en deux dimensions issus d'une pluralité de perspectives par rapport à la surface de ladite zone de tissu en trois dimensions, et le procédé comprend en outre la combinaison de ladite pluralité d'ensembles de données non thermographiques en deux dimensions de façon à former lesdites données non thermographiques en trois dimensions.
35. Procédé selon la revendication 26, qui comprend en outre l'acquisition desdites données thermographiques en deux dimensions, à l'aide d'au moins une fonctionnalité d'acquisition de données d'images

thermographiques (24).

- 36.** Procédé selon la revendication 35, dans lequel ladite acquisition desdites données thermographiques en deux dimensions comprend une pluralité d'étapes d'acquisition de données séquentielles, et le procédé comprend en outre le repositionnement d'au moins l'un de ladite fonctionnalité d'acquisition de données (24) et dudit corps vivant (12) entre des étapes d'acquisition de données successives. 5 10
- 37.** Procédé selon la revendication 35, dans lequel ladite acquisition desdites données thermographiques en deux dimensions comprend l'acquisition simultanée d'ensembles de données thermographiques en deux dimensions depuis une pluralité de perspectives par rapport à la surface de ladite zone de tissu en trois dimensions, et le procédé comprend en outre la combinaison de chaque ensemble de données thermographique en deux dimensions avec lesdites données non thermographiques en trois dimensions. 15 20
- 38.** Procédé selon la revendication 36, dans lequel ladite combinaison est effectuée afin que les données acquises à chaque étape d'acquisition de données thermographiques en deux dimensions soient combinées avec lesdites données non thermographiques en trois dimensions. 25 30
- 39.** Procédé selon la revendication 26, dans lequel ladite combinaison comprend le calcul d'un modèle non thermographique en trois dimensions, et le calcul des données spatiales dudit modèle non thermographique en trois dimensions de façon à générer des données spatiales relatives à l'emplacement et/ou à l'orientation dudit objet thermiquement perceptible (16) dans ledit corps vivant (12). 35
- 40.** Procédé selon la revendication 39, dans lequel ladite combinaison comprend le calcul des données de température spatiales dudit modèle non thermographique en trois dimensions. 40

45

50

55

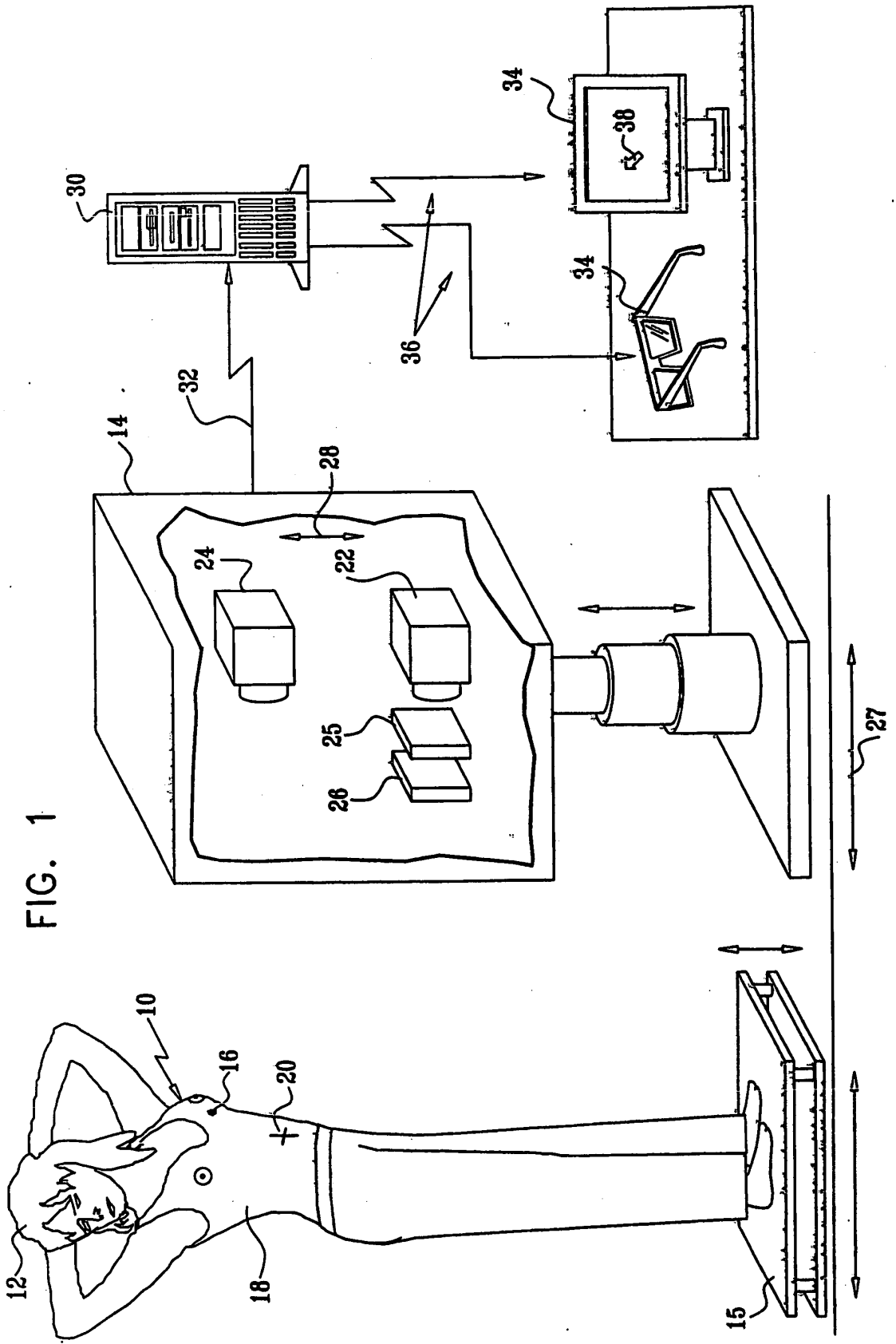

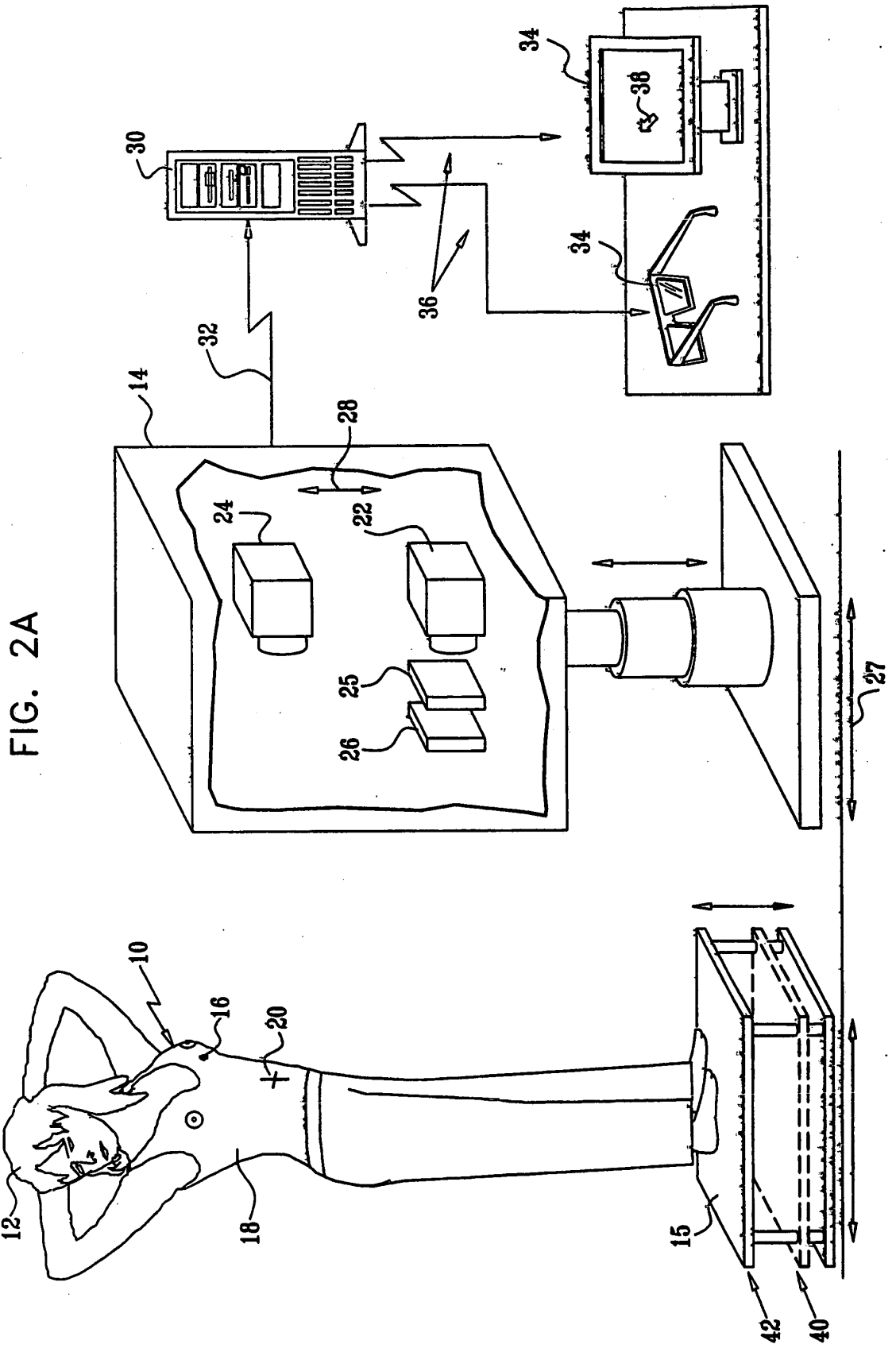

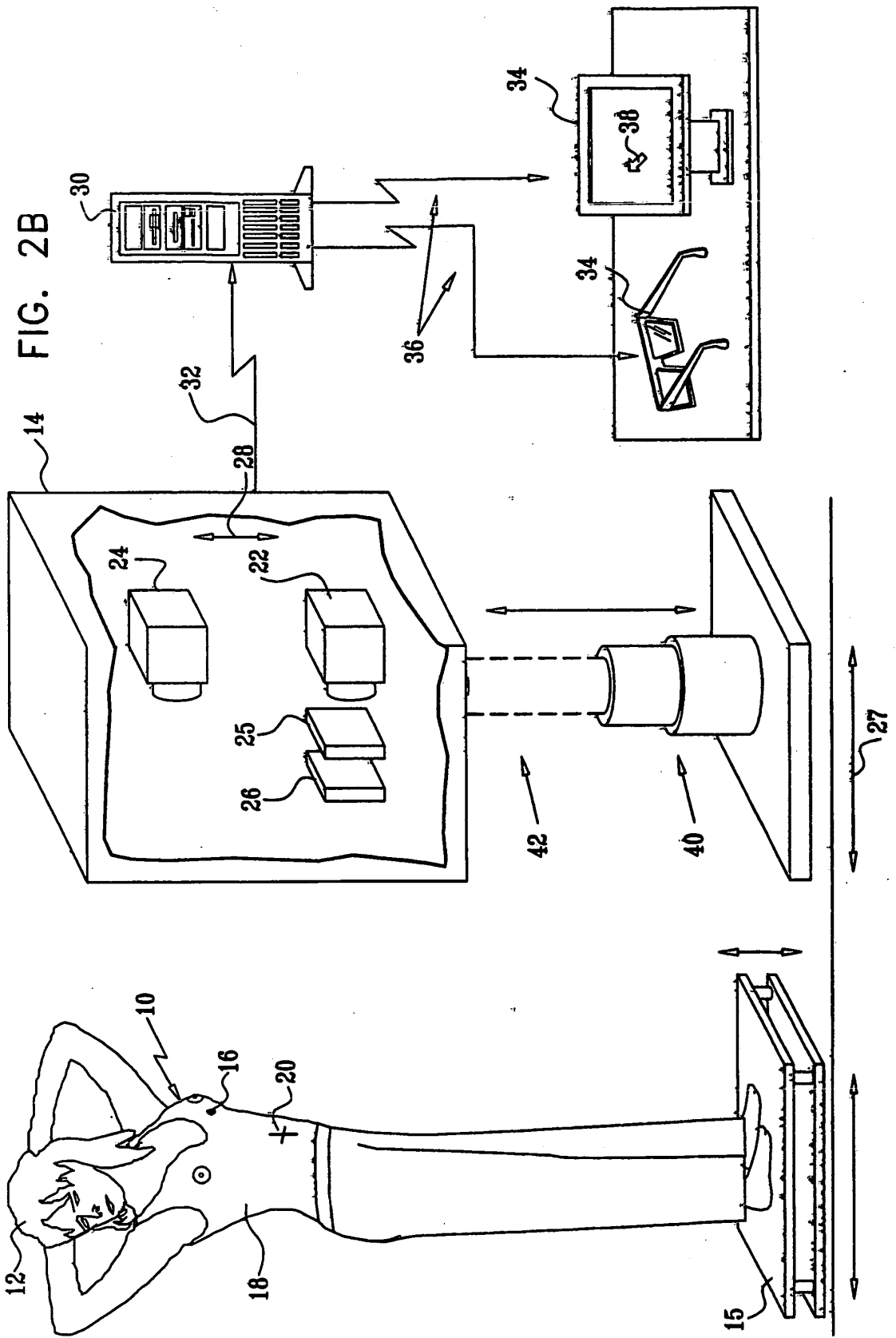

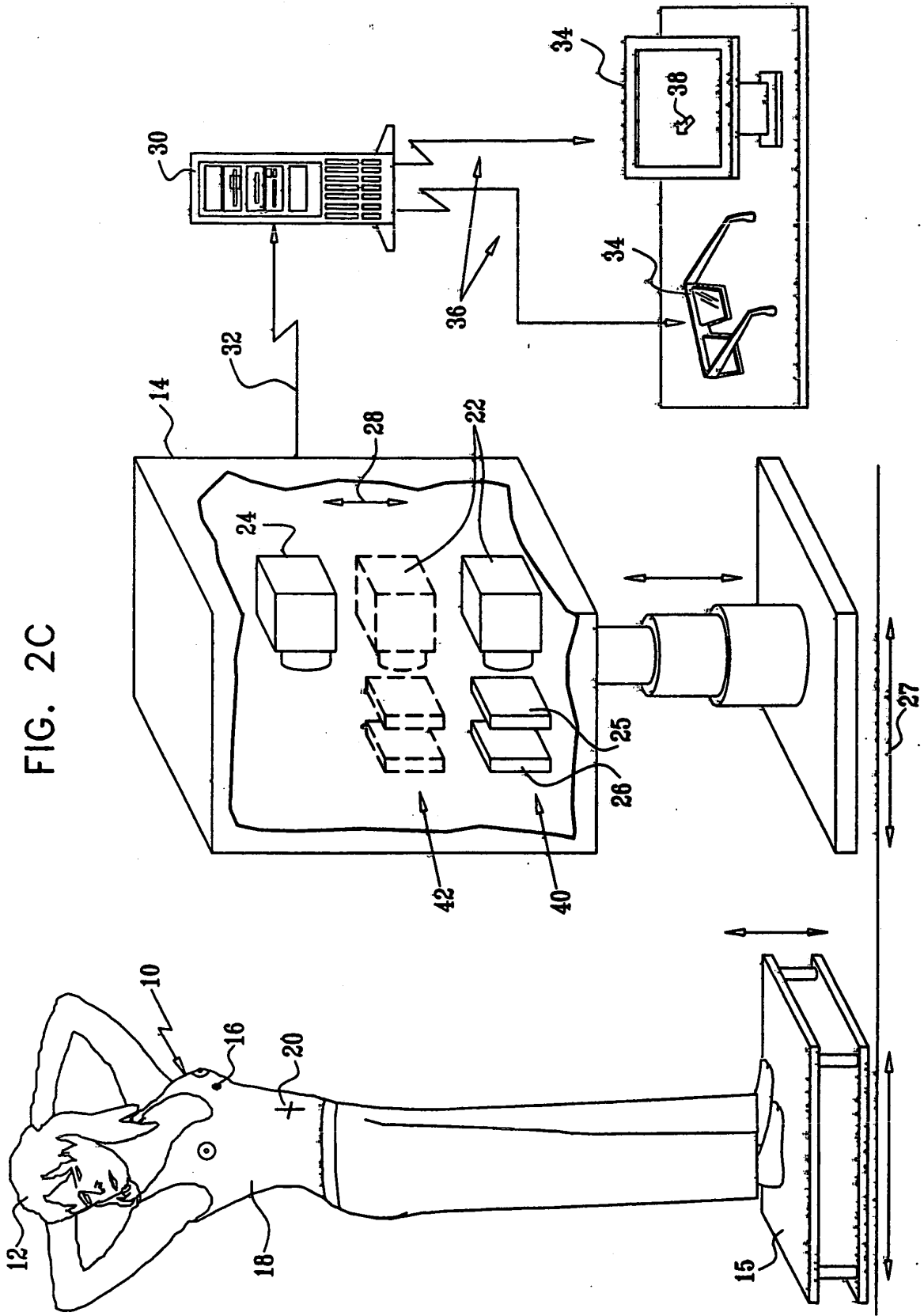

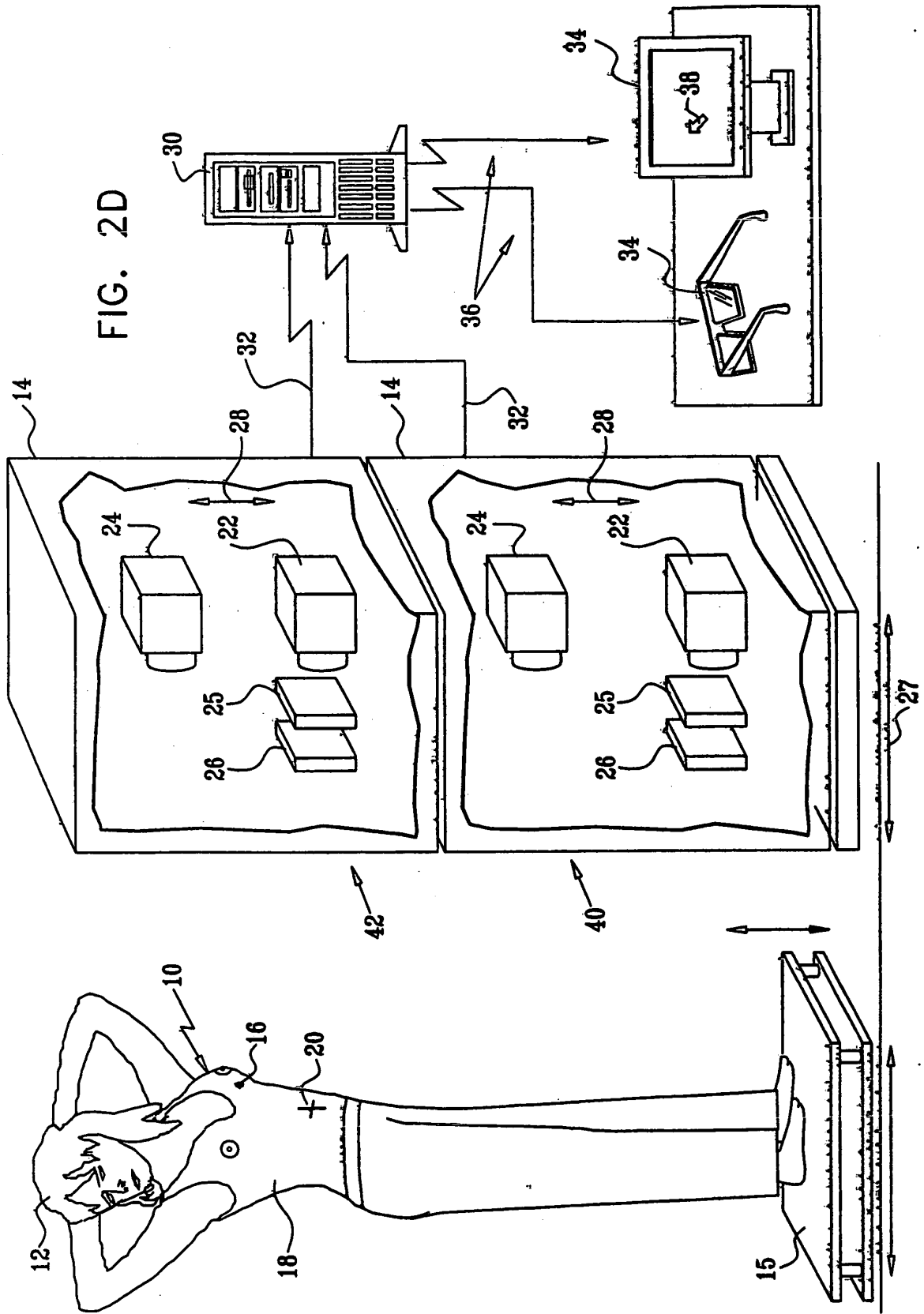
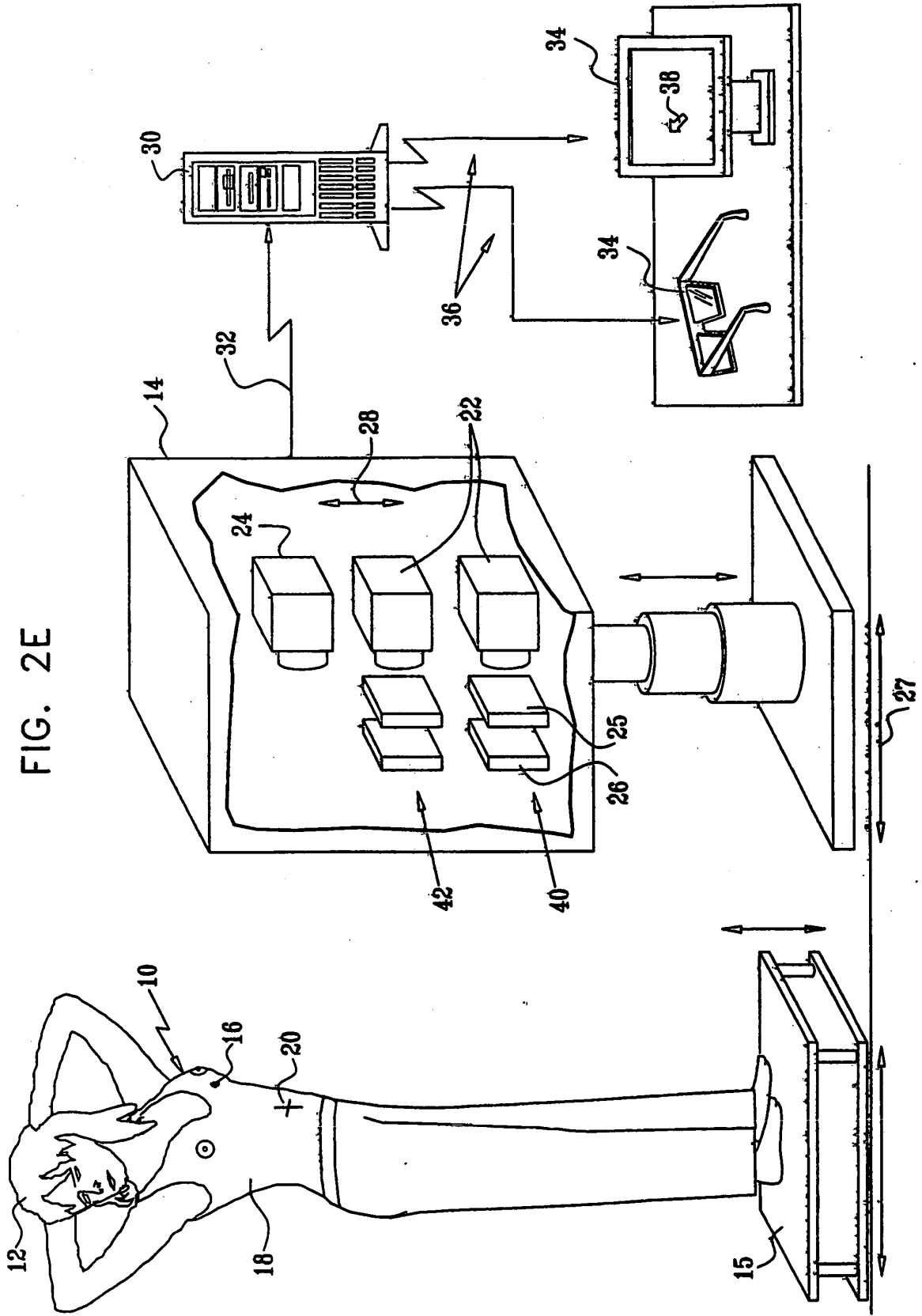
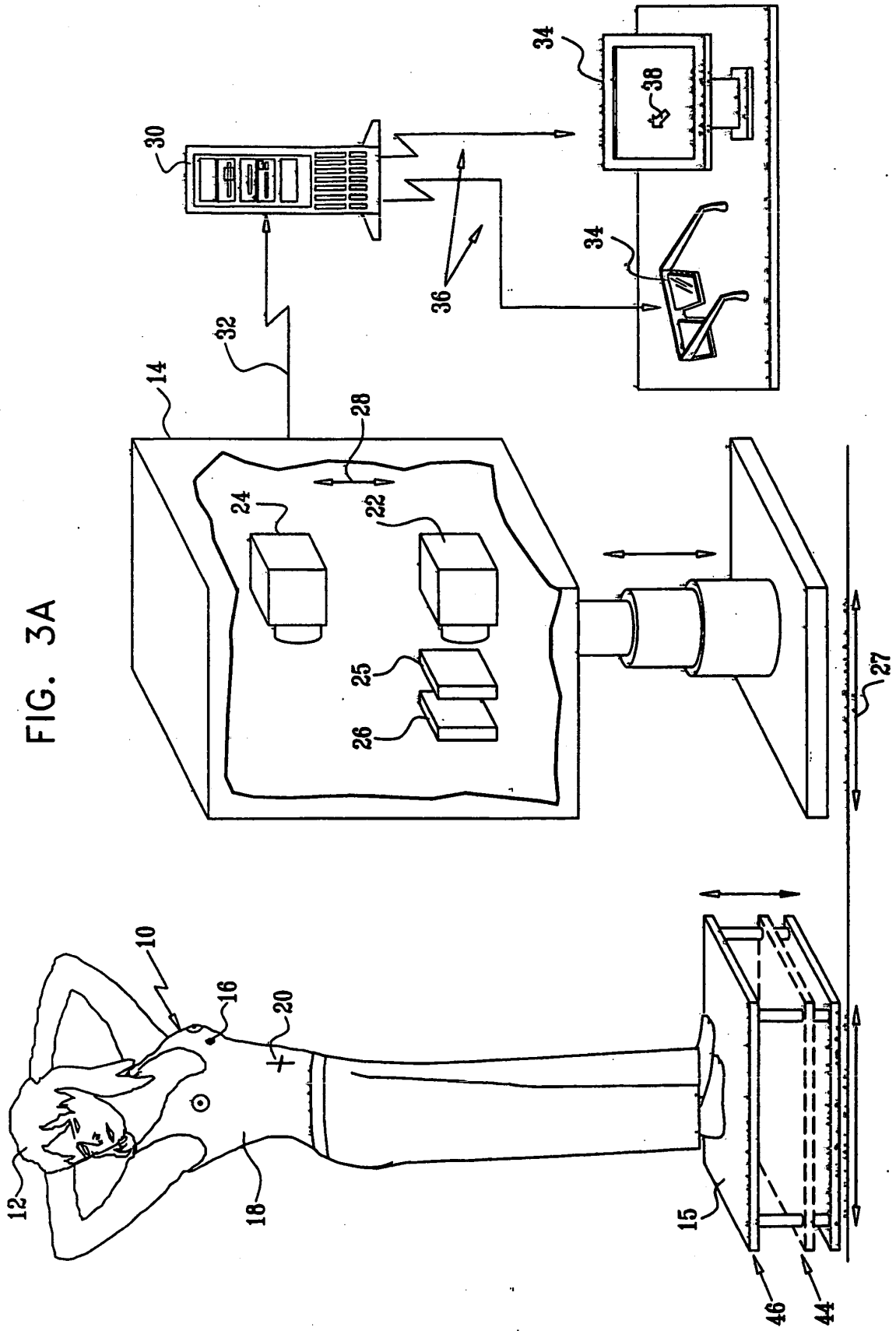
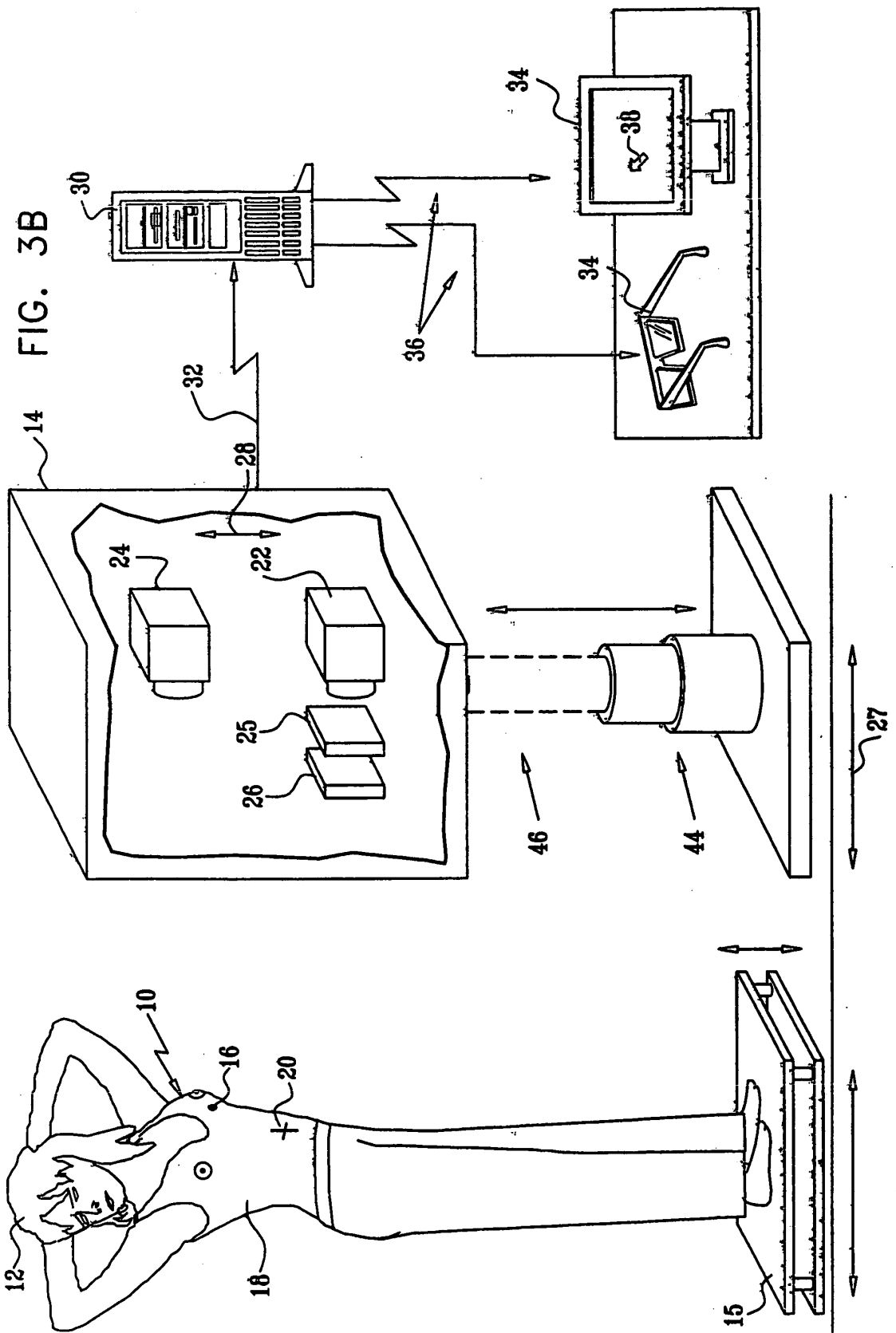
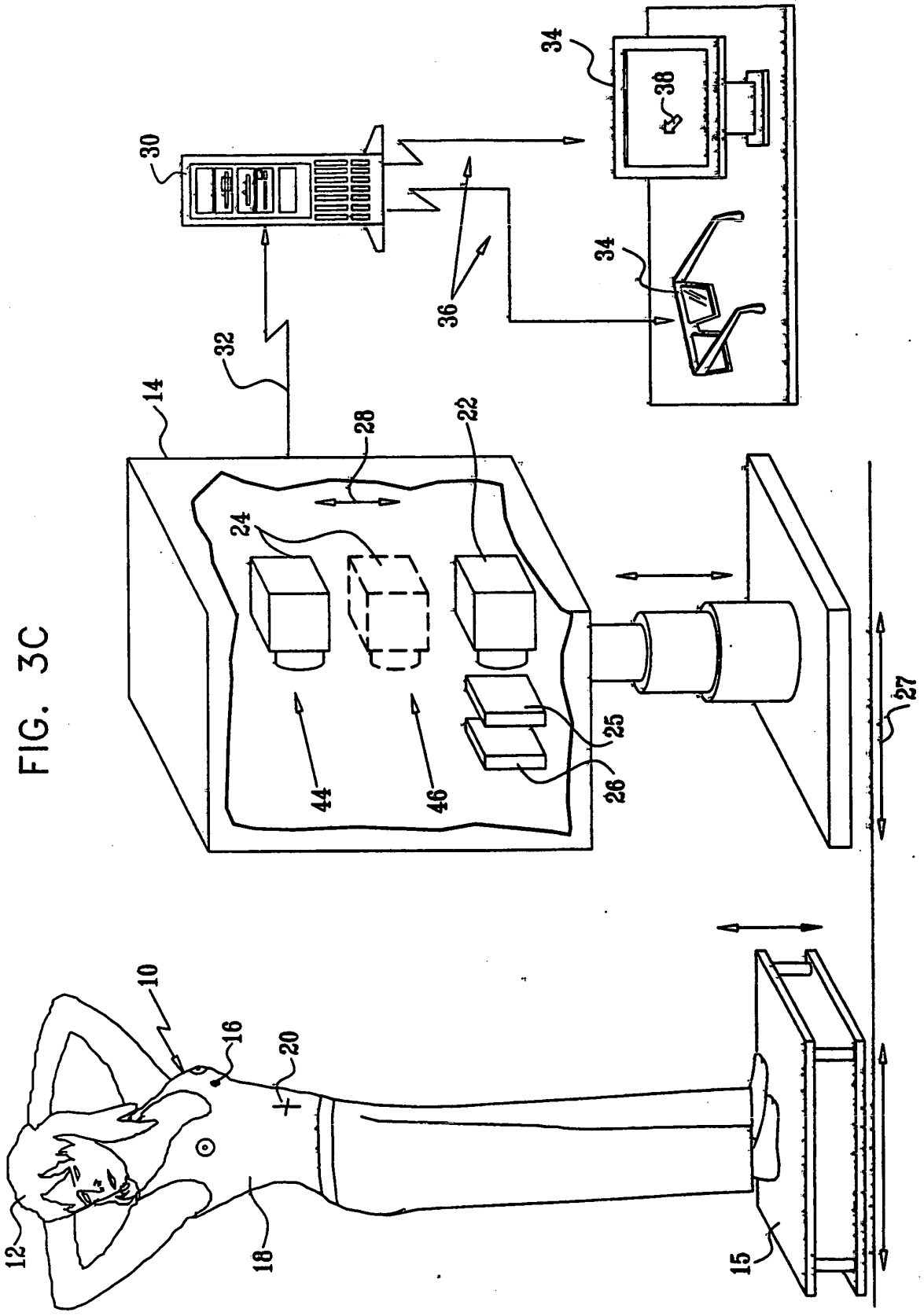

FIG. 2E









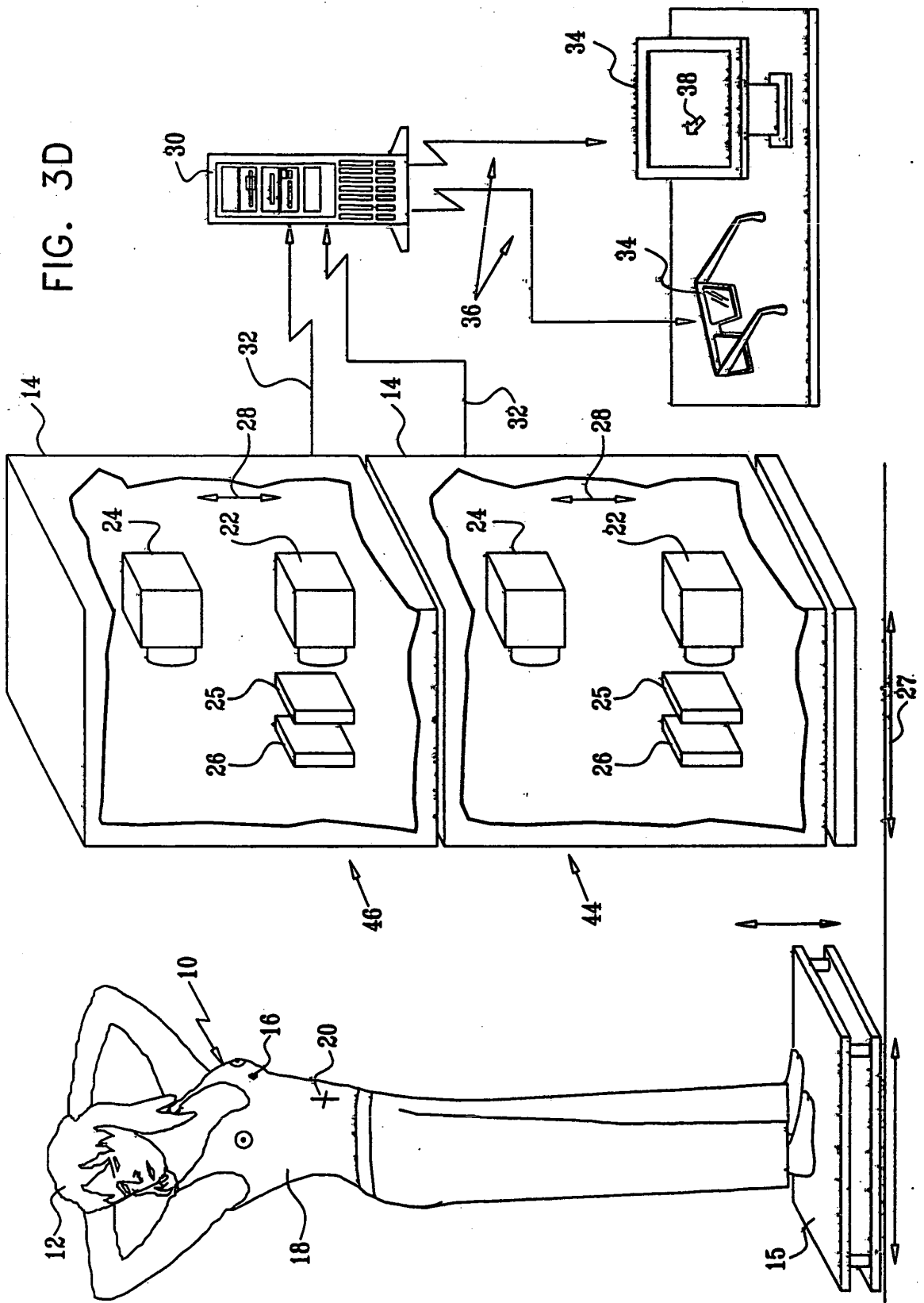

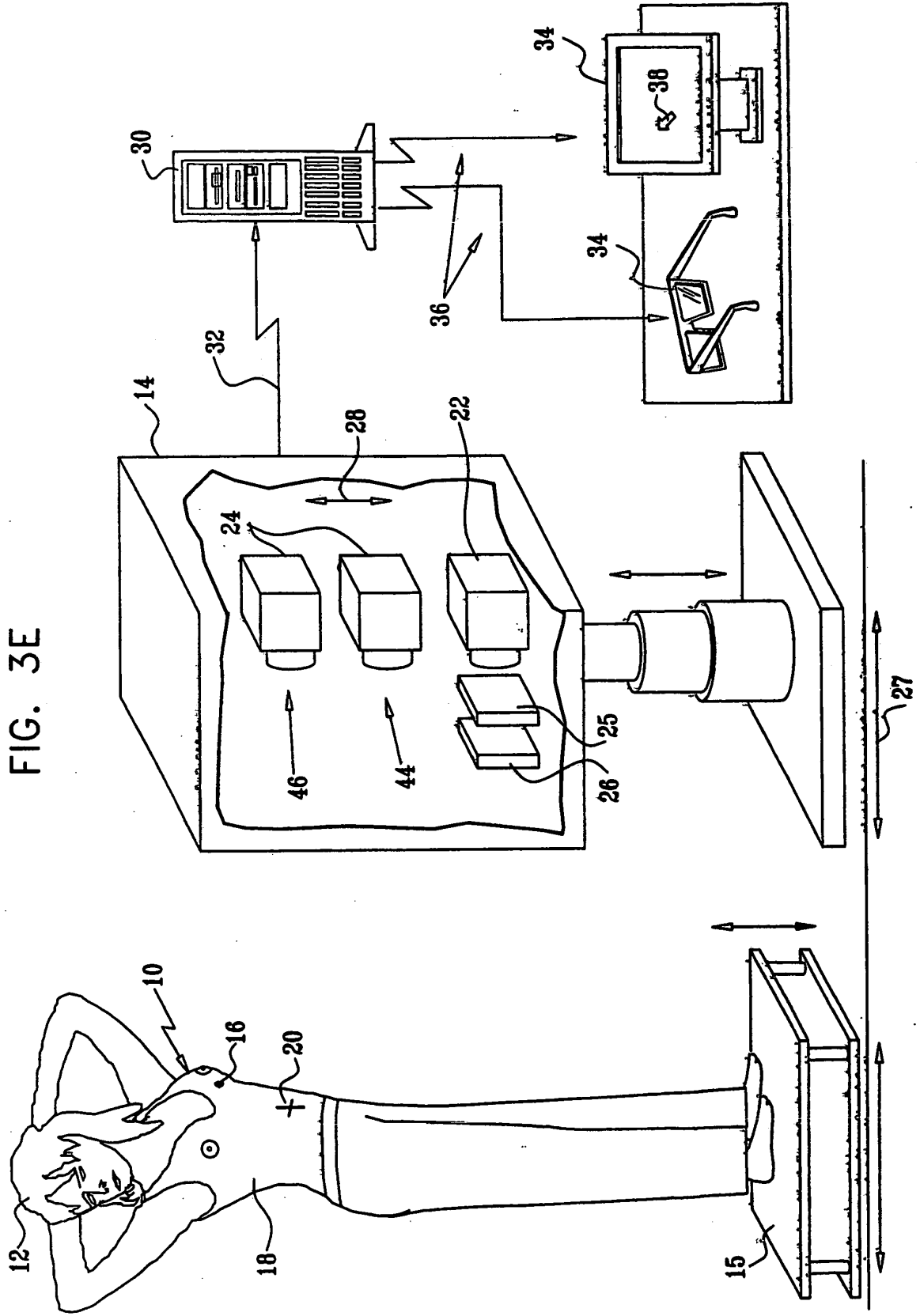

FIG. 4

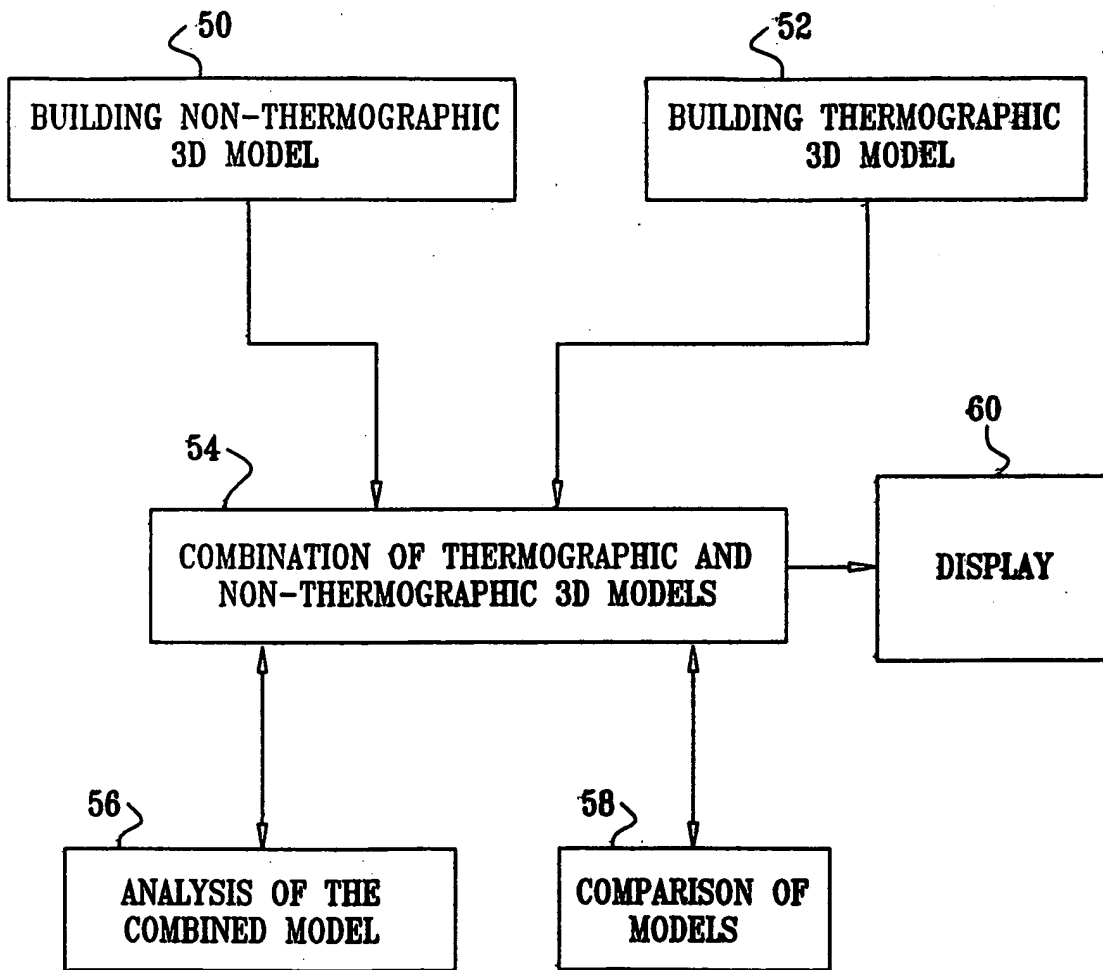

FIG. 5

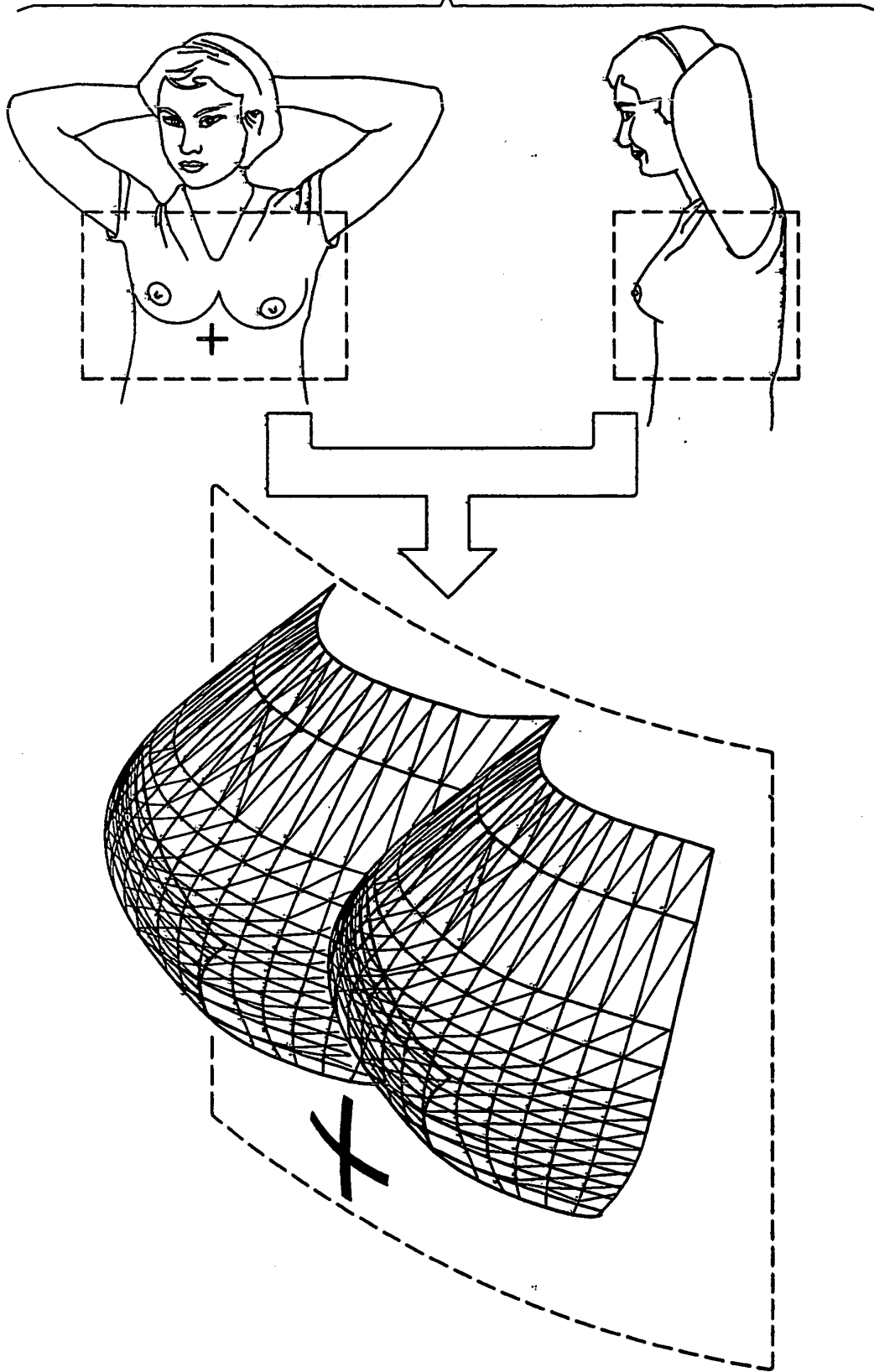

FIG. 6

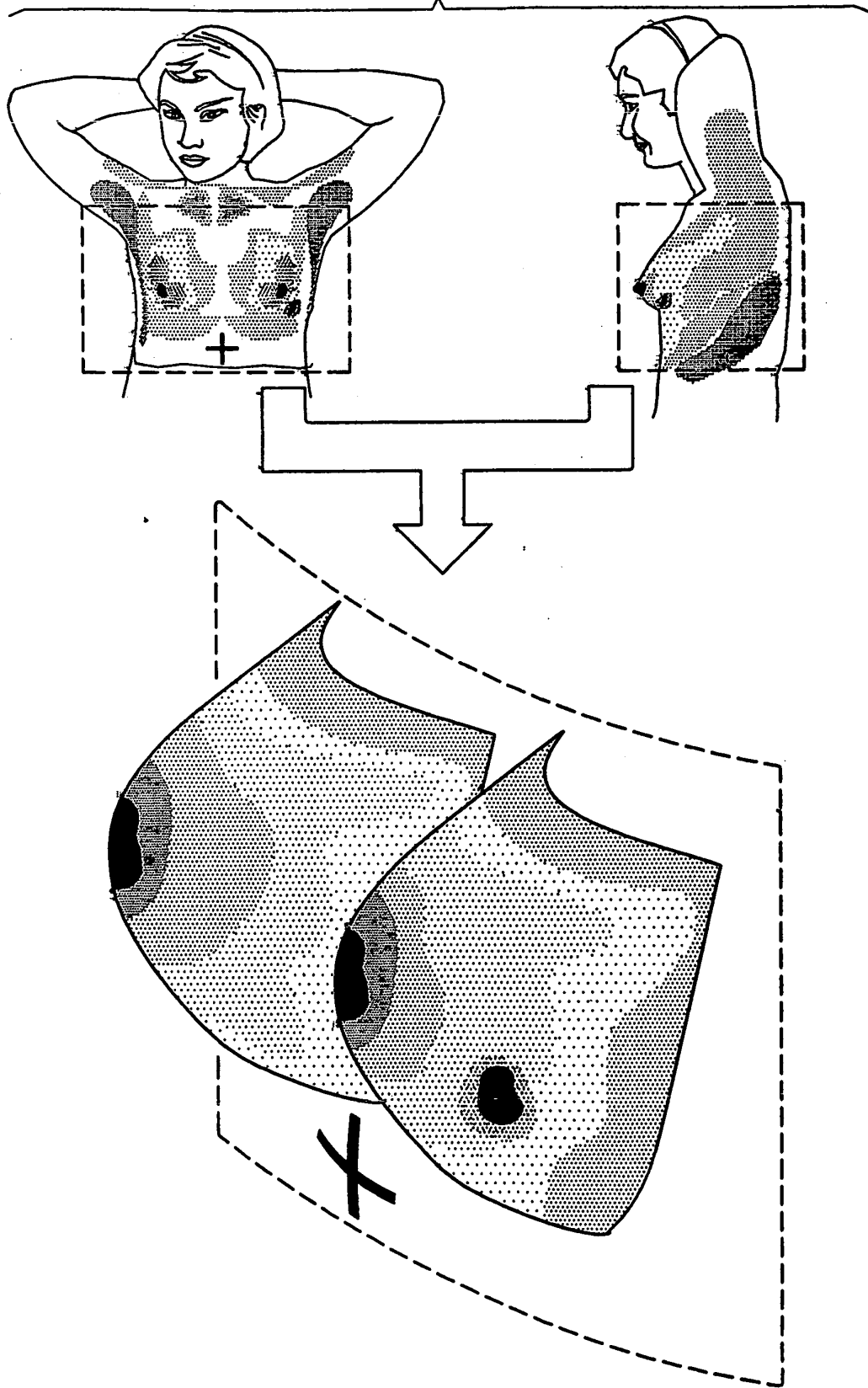
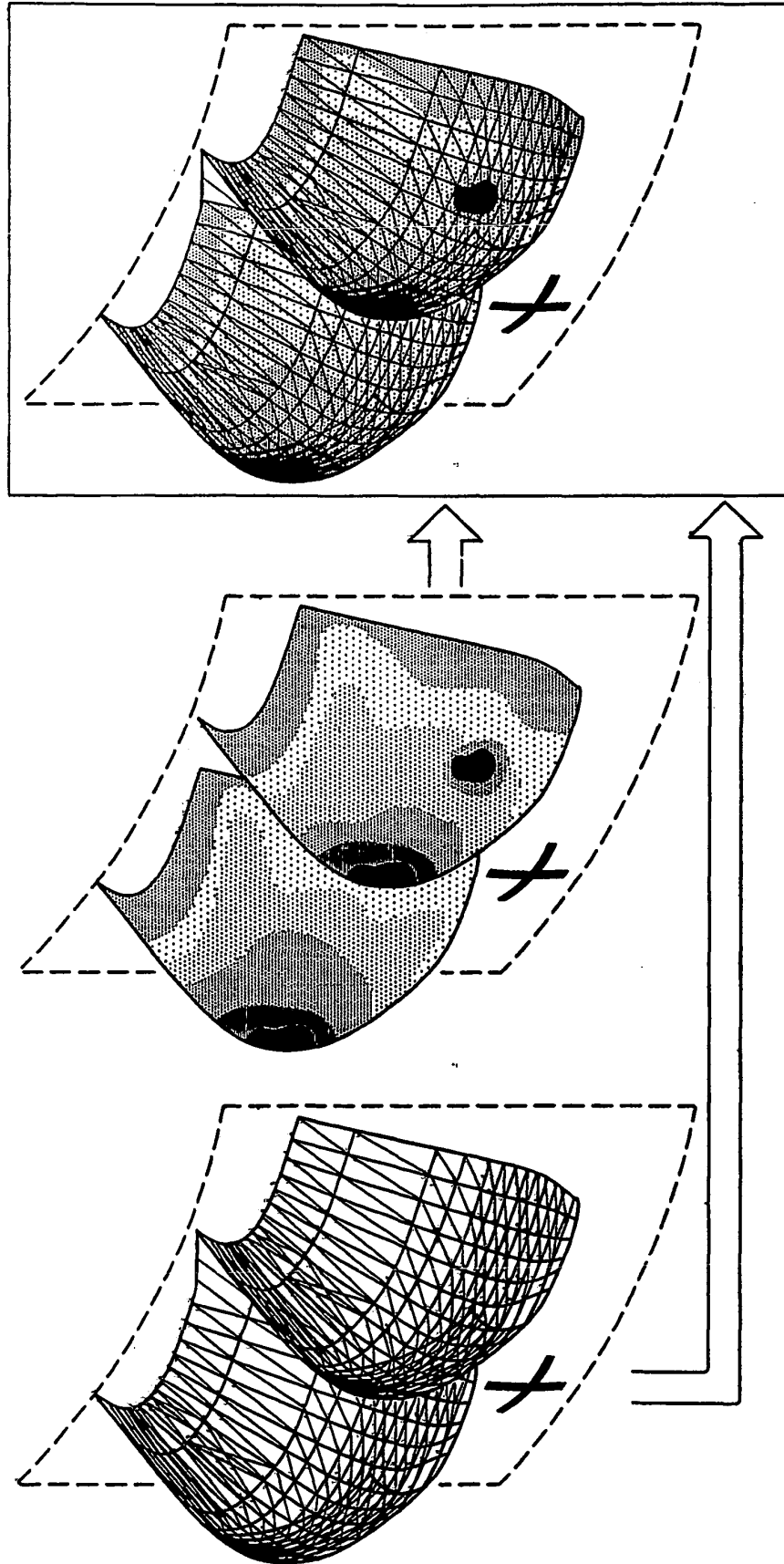

FIG. 7



**REFERENCES CITED IN THE DESCRIPTION**

*This list of references cited by the applicant is for the reader's convenience only. It does not form part of the European patent document. Even though great care has been taken in compiling the references, errors or omissions cannot be excluded and the EPO disclaims all liability in this regard.*

**Patent documents cited in the description**

- US 6442419 B [0002] [0044] [0045]

**Non-patent literature cited in the description**

- **HAI XIAO et al.** Multispectral three-dimensional digital infrared thermal imaging. *Optical Engineering SPINE USA*, April 2003, vol. 42 (4), 906-911 [0003]
- **SMITH et al.** Emerging technologies in breast cancer detection. *Radiology Management*, July 2004, vol. 26 (4), 16-24 [0004]

专利名称(译)	3D热乳腺癌检测仪		
公开(公告)号	<a href="#">EP1766551A4</a>	公开(公告)日	2011-03-02
申请号	EP2005756911	申请日	2005-07-04
[标]申请(专利权)人(译)	真实成像有限公司		
申请(专利权)人(译)	真实影像		
当前申请(专利权)人(译)	真实影像		
[标]发明人	ARNON BOAZ		
发明人	ARNON, BOAZ		
IPC分类号	G06K9/00 B01D61/00 G06T7/00 A61B5/00		
CPC分类号	G06K9/00208 A61B5/0091 A61B5/015 A61B5/4312 A61B5/444 G06K9/00362 G06K9/209 G06K2209/05 G06T7/0012 G06T2207/10048 G06T2207/30068 Y10S128/922		
优先权	60/586162 2004-07-07 US		
其他公开文献	EP1766551B1 EP1766551A2		
外部链接	<a href="#">Espacenet</a>		

摘要(译)

公开了一种用于确定活体中是否存在一个或多个热可区分物体的系统。该系统包括组合图像生成器，其被配置用于将活体中的三维组织区域的非热成像三维数据与组织区域的热成像二维数据组合，以便生成与该组织区域相关联的三维温度数据。三维组织区域。在优选实施例中，组合图像生成器包括计算设备，该计算设备被配置为基于三维温度数据计算三维组织区域中的热可区分对象的位置和/或取向。

