



(11) **EP 1 455 881 B1**

(12) **EUROPEAN PATENT SPECIFICATION**

(45) Date of publication and mention of the grant of the patent:
03.12.2008 Bulletin 2008/49

(21) Application number: **02776024.8**

(22) Date of filing: **26.09.2002**

(51) Int Cl.:
A61M 25/01 (2006.01)

(86) International application number:
PCT/US2002/030771

(87) International publication number:
WO 2003/051445 (26.06.2003 Gazette 2003/26)

(54) **GUIDE WIRE WITH ADJUSTABLE FLEXIBILITY**

FÜHRUNGSDRAHT MIT EINSTELLBARER FLEXIBILITÄT

FIL-GUIDE A SOUPLESSE REGLABLE

(84) Designated Contracting States:
**AT BE BG CH CY CZ DE DK EE ES FI FR GB GR
IE IT LI LU MC NL PT SE SK TR**

(30) Priority: **18.12.2001 US 25428**

(43) Date of publication of application:
15.09.2004 Bulletin 2004/38

(73) Proprietor: **Boston Scientific Limited
St. Michael,
Barbados, West Indies (BB)**

(72) Inventors:
• **GRIFFIN, Stephen
Sunnyvale, CA 94086 (US)**
• **MIRIGIAN, Gregory, E.
Dublin, CA 94568 (US)**

(74) Representative: **Vossius & Partner
Siebertstrasse 4
81675 München (DE)**

(56) References cited:
US-A- 5 349 946 US-A- 5 349 964
US-A- 5 449 369 US-A- 5 938 623
US-A- 5 957 966 US-A1- 2001 039 412

EP 1 455 881 B1

Note: Within nine months of the publication of the mention of the grant of the European patent in the European Patent Bulletin, any person may give notice to the European Patent Office of opposition to that patent, in accordance with the Implementing Regulations. Notice of opposition shall not be deemed to have been filed until the opposition fee has been paid. (Art. 99(1) European Patent Convention).

Description

[0001] The present invention generally relates to intravascular guide wires. In particular, the present invention relates to intravascular guide wires having adjustable flexibility.

[0002] Intravascular guide wires are often used to facilitate the delivery of therapeutic and diagnostic devices to remote vascular sites in the human body. In particular, intravascular guide wires are used to navigate through a patient's vasculature from a convenient location outside the patient's body, to a target site inside the patient's body requiring diagnosis and/or therapy. Once access to the target site has been provided by the guide wire, a therapeutic or diagnostic device (e.g., catheter) may then be advanced over the guide wire to the target site, and the desired therapeutic or diagnostic steps may be performed.

[0003] To facilitate navigation in tortuous vasculature, it is desirable that the guide wire have a relatively flexible distal end. To provide good support for devices advanced over the guide wire, it is desirable that the guide wire have a relatively stiff distal end. Conventional guide wires typically address these competing needs by establishing a compromise in flexibility and stiffness. However, it would be desirable to have a guide wire that does not compromise these competing needs.

[0004] To address these needs, the present invention provides a guide wire that has a distal portion with adjustable flexibility. The guide wire includes a distal polymeric member and a heat source. The heat source may be activated by a power supply, which causes the polymeric member to increase in temperature, to thereby increase the flexibility of the distal portion of the guide wire. The polymeric member may comprise a shape memory polymer having a glass transition temperature, wherein the increase in temperature is across the glass transition temperature.

[0005] The increase in flexibility of the distal portion of the guide wire enhances the ability of the guide wire to navigate vasculature of varying degrees of tortuosity. After the guide wire has been navigated to the target site, the heat source may be deactivated, which causes the polymeric member to decrease in temperature, to thereby increase the stiffness of the distal portion of the guide wire and provide enhanced support for devices advanced thereon.

[0006] Figure 1 is a plan view of a guide wire system, including a guide wire, a controller/power source and a coupling/lead therebetween, in accordance with an exemplary embodiment of the present invention; and Figure 2 is a longitudinal cross-sectional view taken along line 2 - 2 in Figure 1, illustrating in detail the distal portion of the guide wire shown in Figure 1.

[0007] The following description should be read with reference to the drawings wherein like reference numerals indicate like elements throughout the several views. The detailed description and drawings illustrate embod-

iments by way of example, not limitation.

[0008] Refer now to Figure 1 which illustrates a guide wire system in accordance with an exemplary embodiment of the present invention. The guide wire system includes a guide wire 10 connected to a controller and power source 50 by a coupling 40 and lead 60.

[0009] Guide wire 10 includes an elongate shaft 12 having a proximal portion 14 and a distal portion 16. Distal portion 16 includes a soft atraumatic tip 18. The proximal portion 14 of the shaft 12 is relatively stiff to provide pushability and torquability, and the distal portion 16 has adjustable flexibility to provide trackability in navigating tortuous vasculature and support for devices advanced thereover.

[0010] Except as described herein and implicit in the drawings, the guide wire 10 may have conventional dimensions and may be formed of conventional materials using conventional techniques known for intravascular guide wires used to navigate the human vasculature to remote locations including, but not limited to, the neurovasculature, the coronary vasculature, and the peripheral vasculature.

[0011] As will be discussed in more detail with reference to Figure 2, the distal portion 16 of the guide wire 10 includes a heat source that is thermally connected to a polymeric member that increases in flexibility when heated, and increases in stiffness (e.g., returns to its nominal flexibility or stiffness at body temperature) when cooled. Thus, by activating or deactivating the heat source, the flexibility of the polymeric member, and thus the flexibility of the distal portion 16, may be adjusted. For example, the flexibility of the distal portion 16 may be increased by activating the heat source, which enhances the ability of the guide wire 10 to navigate tortuous vasculature to a target site. After the guide wire 10 has been navigated to the desired target site, the heat source may be deactivated to cause the distal portion 16 to increase in stiffness, which enhances guide wire 10 support provided for devices (e.g., catheters) advanced thereon.

[0012] To control activation and deactivation of the heat source, a controller/power supply 50 is connected by lead 60 to a coupling 40 which is releasably and rotatably connected to the proximal portion 14 of the guide wire shaft 12. Controller/power supply 50 may comprise a conventional power supply with conventional control circuitry to provide a constant or modulated AC or DC signal. The signal is transmitted by lead 60, which may comprise two (or more) conductors. The conductors in the lead 60 may be connected to leads in the shaft 12 of the guide wire by coupling 40. Coupling 40 may be removable to permit devices such as catheters to be advanced over the proximal end of the guide wire 10. Coupling 40 may also be rotatable to permit the guide wire to be rotated and steered during intravascular navigation.

[0013] Refer now to Figure 2 which illustrates in detail certain aspects of the distal portion 16 of the guide wire 10, which may be in common with certain aspects of the

proximal portion 14. As seen in Figure 2, the shaft 12 includes a hypotube 22 which may comprise, for example, stainless steel or a super elastic metal such as a nickel titanium alloy, Nitinol, MP35N, Inconel, etc. The hypotube 22 may extend from the proximal end of the guide wire shaft 12, and may include an outer sleeve 24 comprising a polymer such as polyurethane. A tapered core wire 26 may extend through the lumen in the hypotube 22, and may comprise stainless steel or a super elastic metal such as a nickel titanium alloy, Nitinol, MP35N, Inconel, etc. The distal end of the hypotube 22 in the region of the distal tip 18 may be helically slotted 28 to enhance flexibility. The distal end of the core wire 26 may be welded to the distal end of the slotted portion 28 of the hypotube 22 to form an atraumatic weld ball 30.

[0014] As mentioned previously, the distal portion 16 of the guide wire shaft 12 includes a heat source. In this particular example, the heat source comprises a resistive element 32. Resistive element 32 may comprise a tungsten or steel alloy that may be formed into a coil and heated by electro-resistive heating. Heater coil 32 may be disposed between adjacent turns in the slotted portion 28 of the hypotube 22. The resistive heater coil 32 is connected to insulated leads 34 which may be disposed in the lumen of the hypotube 22 around the core wire 26. Leads 34 are connected to coupling 40, which in turn is connected to controller/power supply 50 via lead 60.

[0015] A polymeric outer tube 36 may be disposed about the resistive heater coil 32, and a polymeric inner tube 38 may be provided to support the heater coil 32. The polymeric outer tube 36 and/or the polymeric inner tube 38 may be formed of a polymer that changes in stiffness when heated. For example, the polymeric outer tube 36 and/or the polymeric inner tube 38 may be formed of a polymer that is relatively stiff at temperatures at or below body temperature (37°C or less) and relatively flexible at temperatures above body temperature. For example, a polymer may be selected with a glass transition temperature (T_g) that is above body temperature, such that heating the polymer above T_g results in the distal portion 16 of the guide wire 10 becoming relatively more flexible, and cooling the polymer below T_g , even when the guide wire 10 is disposed in the patient's body, results in the distal portion 16 of the guide wire 10 becoming relatively more stiff. In a preferred embodiment, the polymeric outer tube 36 and/or the polymeric inner tube 38 may be formed of a shape memory polymer (SMP) such as a shape memory polyurethane available from Mitsubishi. Other examples of suitable SMPs include polynorbornenes, polycaprolactones and copolymers thereof available from Pneumosience. Some SMPs, such as polynorbomene, may change flexibility without changing temperature across T_g . Such SMPs may be above T_g at room temperature or body temperature, and may exhibit SMP characteristics at or near the melt temperature (T_m).

[0016] It should be understood that this disclosure is, in many respects, only illustrative. Changes may be made in details, particularly in matters of shape, size,

arrangement of parts and order of steps without departing from the scope of the invention. The invention's scope is, of course, defined in the language in which the appended claims are expressed.

Claims

1. A variable stiffness guide wire, comprising:

a guide wire shaft including a proximal portion and a distal portion having a flexibility;
a polymeric member disposed on the distal portion of the shaft; and

a heat source in thermal communication with the polymeric member, whereby activation of the heat source causes the polymeric member to change the flexibility of the distal portion of the guide wire shaft.

2. A variable stiffness guide wire as in claim 1, wherein the polymeric member has a first flexibility at a first temperature and a second flexibility at a second temperature, wherein the first temperature is less than the second temperature and the first flexibility is less than the second flexibility; and whereby activation of the heat source causes the polymeric member to rise from the first temperature to the second temperature to thereby change the flexibility of the distal portion of the guide wire.

3. A variable stiffness guide wire as in claim 1, wherein the polymeric member comprises a shape memory polymer.

4. A variable stiffness guide wire as in claim 3, wherein activation of the heat source causes the shape memory polymer to change temperature.

5. A variable stiffness guide wire as in claim 4, wherein the shape memory polymer has a glass transition temperature, and wherein the change in temperature is across the glass transition temperature.

6. A variable stiffness guide wire as in claim 4, wherein the shape memory polymer has a glass transition temperature, and wherein the change in temperature is near the melt temperature.

7. A variable stiffness guide wire as in claim 1, wherein the heat source comprises a resistive heating element.

8. A variable stiffness guide wire as in claim 7, wherein the distal portion of the shaft includes a tip portion.

9. A variable stiffness guide wire as in claim 8, wherein the tip portion includes the polymeric member and

resistive heating element.

10. A variable stiffness guide wire as in claim 9, wherein the polymeric member comprises a tube.
11. A variable stiffness guide wire as in claim 10, wherein the resistive heating element comprises a coiled wire.
12. A variable stiffness guide wire as in claim 11, further comprising one or more lead wires connected to and extending proximally from the coiled wire.
13. A variable stiffness guide wire as in claim 12, where in the polymeric tube is disposed on the coiled wire.
14. A variable stiffness guide wire as in claim 13, wherein a core wire extends through the tip portion.
15. A variable stiffness guide wire as in claim 14, wherein the proximal portion of the guide wire shaft includes a hypotube.
16. A variable stiffness guide wire as in claim 15, wherein the distal portion of the guide wire shaft includes a slotted hypotube.
17. A variable stiffness guide wire as in claim 16, wherein the coiled wire is disposed in the slots of the slotted hypotube.
18. A variable stiffness guide wire system, comprising:

the variable stiffness guidewire as in claim 1; and a power supply connected to the heat source, whereby activation of the heat source by the power supply causes the polymeric member to change the flexibility of the distal portion of the guide wire.

Patentansprüche

1. Führungsdraht mit variabler Steifigkeit, der aufweist:

einen Führungsdrahtschaft mit einem proximalen Abschnitt und einem distalen Abschnitt mit einer Flexibilität;
ein Polymerteil, das am distalen Abschnitt des Schafts angeordnet ist; und
eine Wärmequelle in Wärmeübertragungsverbindung mit dem Polymerteil, wodurch eine Aktivierung der Wärmequelle bewirkt, daß das Polymerteil die Flexibilität des distalen Abschnitts des FührungsdrahtsCHAFTS ändert.
2. Führungsdraht mit variabler Steifigkeit nach Anspruch 1, wobei das Polymerteil eine erste Flexibilität

bei einer ersten Temperatur und eine zweite Flexibilität bei einer zweiten Temperatur hat, wobei die erste Temperatur kleiner als die zweite Temperatur ist und die erste Flexibilität kleiner als die zweite Flexibilität ist; und wodurch eine Aktivierung der Wärmequelle bewirkt, daß die Temperatur des Polymer-teils von der ersten Temperatur zur zweiten Temperatur ansteigt, um **dadurch** die Flexibilität des distalen Abschnitts des Führungsdrahts zu ändern.

5

10

15

20

25

30

35

40

45

50

55

3. Führungsdraht mit variabler Steifigkeit nach Anspruch 1, wobei das Polymerteil ein Formgedächtnispolymer aufweist.

4. Führungsdraht mit variabler Steifigkeit nach Anspruch 3, wobei eine Aktivierung der Wärmequelle bewirkt, daß das Formgedächtnispolymer die Temperatur ändert.

5. Führungsdraht mit variabler Steifigkeit nach Anspruch 4, wobei das Formgedächtnispolymer eine Glasübergangstemperatur hat und wobei die Änderung der Temperatur über die Glasübergangstemperatur hinweg erfolgt.

6. Führungsdraht mit variabler Steifigkeit nach Anspruch 4, wobei das Formgedächtnispolymer eine Glasübergangstemperatur hat und wobei die Änderung der Temperatur nahe der Schmelztemperatur ist.

7. Führungsdraht mit variabler Steifigkeit nach Anspruch 1, wobei die Wärmequelle ein Widerstandsheizelement aufweist.

8. Führungsdraht mit variabler Steifigkeit nach Anspruch 7, wobei der distale Abschnitt des Schafts einen Spitzenabschnitt aufweist.

9. Führungsdraht mit variabler Steifigkeit nach Anspruch 8, wobei der Spitzenabschnitt das Polymerteil und das Widerstandsheizelement aufweist.

10. Führungsdraht mit variabler Steifigkeit nach Anspruch 9, wobei das Polymerteil eine Röhre aufweist.

11. Führungsdraht mit variabler Steifigkeit nach Anspruch 10, wobei das Widerstandsheizelement einen gewendelten Draht aufweist.

12. Führungsdraht mit variabler Steifigkeit nach Anspruch 11, ferner mit einem oder mehreren Anschlußdrähten, die mit dem gewendelten Draht verbunden sind und sich proximal von diesem erstrecken.

13. Führungsdraht mit variabler Steifigkeit nach Anspruch 12, wobei die Polymerröhre auf dem gewen-

delten Draht angeordnet ist.

14. Führungsdraht mit variabler Steifigkeit nach Anspruch 13, wobei sich ein Kerndraht durch den Spitzenabschnitt erstreckt.
15. Führungsdraht mit variabler Steifigkeit nach Anspruch 14, wobei der proximale Abschnitt des Führungsdrahts eine Hypotube aufweist.
16. Führungsdraht mit variabler Steifigkeit nach Anspruch 15, wobei der distale Abschnitt des Führungsdrahts eine geschlitzte Hypotube aufweist.
17. Führungsdraht mit variabler Steifigkeit nach Anspruch 16, wobei der gewendelte Draht in den Schlitzen der geschlitzten Hypotube angeordnet ist.
18. Führungsdrahtsystem mit variabler Steifigkeit, das aufweist:

den Führungsdraht mit variabler Steifigkeit nach Anspruch 1; und
eine Stromversorgung, die mit der Wärmequelle verbunden ist, wodurch eine Aktivierung der Wärmequelle durch die Stromversorgung bewirkt, daß das Polymerteil die Flexibilität des distalen Abschnitts des Führungsdrahts ändert.

Revendications

1. Fil de guidage à rigidité variable, comprenant :

un arbre de fil de guidage comprenant une partie proximale et une partie distale présentant une souplesse ;
un élément polymérique disposé sur la partie distale de l'arbre ; et
une source de chaleur en communication thermique avec l'élément polymérique, moyennant quoi l'activation de la source de chaleur amène l'élément polymérique à modifier la souplesse de la partie distale de l'arbre de fil de guidage.

2. Fil de guidage à rigidité variable selon la revendication 1, dans lequel l'élément polymérique a une première souplesse à une première température et une deuxième souplesse à une deuxième température, dans lequel la première température est inférieure à la deuxième température et la première souplesse est inférieure à la deuxième souplesse ; et moyennant quoi l'activation de la source de chaleur amène l'élément polymérique à s'élever de la première température à la deuxième température pour, de ce fait, modifier la souplesse de la partie distale du fil de guidage.

3. Fil de guidage à rigidité variable selon la revendication 1, dans lequel l'élément polymérique comprend un polymère à mémoire de forme.

- 5 4. Fil de guidage à rigidité variable selon la revendication 3, dans lequel l'activation de la source de chaleur amène le polymère à mémoire de forme à changer de température.

- 10 5. Fil de guidage à rigidité variable selon la revendication 4, dans lequel le polymère à mémoire de forme a une température de transition vitreuse, et dans lequel le changement de température croise la température de transition vitreuse.

- 15 6. Fil de guidage à rigidité variable selon la revendication 4, dans lequel le polymère à mémoire de forme a une température de transition vitreuse, et dans lequel le changement de température est proche de la température de fusion.

7. Fil de guidage à rigidité variable selon la revendication 1, dans lequel la source de chaleur comprend un élément chauffant résistif.

- 25 8. Fil de guidage à rigidité variable selon la revendication 7, dans lequel la partie distale de l'arbre comprend une partie d'extrémité.

- 30 9. Fil de guidage à rigidité variable selon la revendication 8, dans lequel la partie d'extrémité comprend l'élément polymérique et l'élément chauffant résistif.

- 35 10. Fil de guidage à rigidité variable selon la revendication 9, dans lequel l'élément polymérique comprend un tube.

- 40 11. Fil de guidage à rigidité variable selon la revendication 10, dans lequel l'élément chauffant résistif comprend un fil spiralé.

- 45 12. Fil de guidage à rigidité variable selon la revendication 11, comprenant en outre un ou plusieurs fils conducteurs connectés au fil spiralé et s'étendant à proximité de celui-ci.

13. Fil de guidage à rigidité variable selon la revendication 12, dans lequel le tube polymérique est disposé sur le fil spiralé.

- 50 14. Fil de guidage à rigidité variable selon la revendication 13, dans lequel un fil central s'étend à travers la partie d'extrémité.

- 55 15. Fil de guidage à rigidité variable selon la revendication 14, dans lequel la partie proximale de l'arbre de fil de guidage comprend un hypotube.

16. Fil de guidage à rigidité variable selon la revendication 15, dans lequel la partie distale de l'arbre de fil de guidage comprend un hypotube à fentes.
17. Fil de guidage à rigidité variable selon la revendication 16, dans lequel le fil spiralé est disposé dans les fentes de l'hypotube à fentes. 5
18. Système de fil de guidage à rigidité variable, comprenant : 10
- le fil de guidage à rigidité variable selon la revendication 1 ; et
- une alimentation connectée à la source de chaleur, moyennant quoi l'activation de la source de chaleur par l'alimentation amène l'élément polymérique à modifier la souplesse de la partie distale du fil de guidage. 15

20

25

30

35

40

45

50

55

Fig. 1

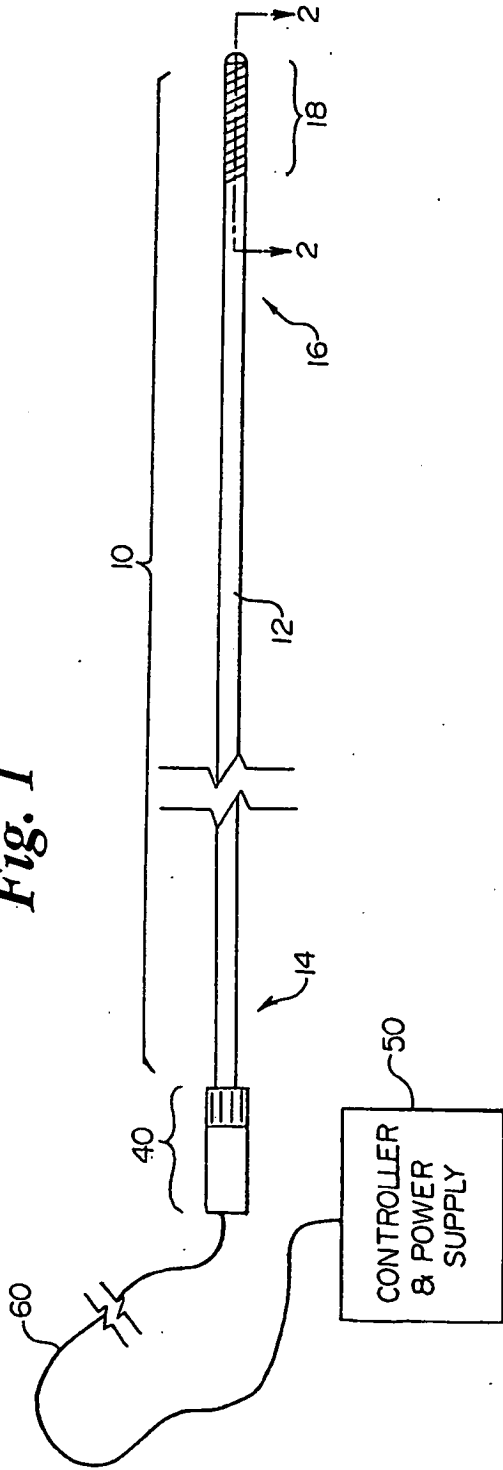
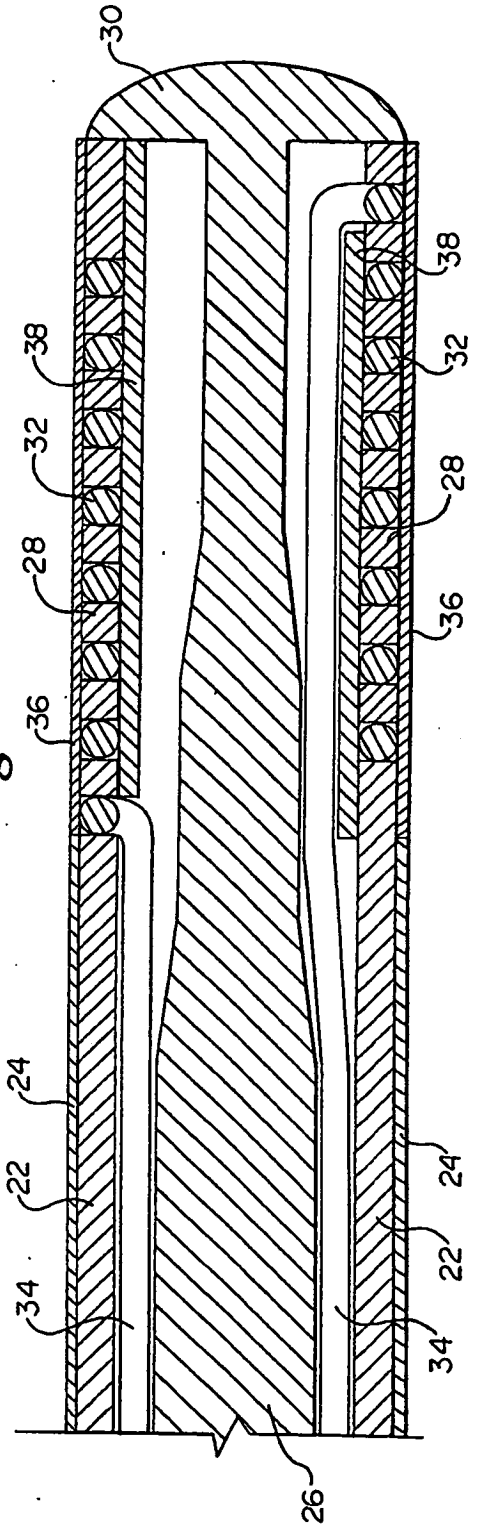

Fig. 2



专利名称(译)	导丝具有可调节的灵活性		
公开(公告)号	EP1455881B1	公开(公告)日	2008-12-03
申请号	EP2002776024	申请日	2002-09-26
[标]申请(专利权)人(译)	波士顿科学有限公司		
申请(专利权)人(译)	BOSTON SCIENTIFIC LIMITED		
当前申请(专利权)人(译)	BOSTON SCIENTIFIC LIMITED		
[标]发明人	GRIFFIN STEPHEN MIRIGIAN GREGORY E		
发明人	GRIFFIN, STEPHEN MIRIGIAN, GREGORY, E.		
IPC分类号	A61M25/01 A61B5/00 A61M25/00		
CPC分类号	A61M25/09 A61M2025/0915 A61M2025/09175		
代理机构(译)	法思博事务所		
优先权	10/025428 2001-12-18 US		
其他公开文献	EP1455881A1		
外部链接	Espacenet		

摘要(译)

一种导丝，其远端部分具有可调节的柔韧性。导丝可包括远端聚合物构件和热源。可以激活热源以使聚合物构件的温度升高并增加柔韧性。导丝远端部分的柔韧性的增加增强了导丝将曲折脉管系统导向目标部位的能力。在导丝已经导航到目标位置之后，可以停用热源以使聚合物构件的温度降低并且增加刚度。导丝远端部分的刚度的增加增强了对在其上前进的装置（例如，导管）提供的支撑。

